

FACTORY AUTOMATION

Programmable Automation Controllers MELSEC MX Controller





Mitsubishi Electric Corporation operates across a wide range of sectors, from home appliances and building systems to railway solutions, factory automation equipment, and satellites and leverages the synergy created by these diverse sectors to address various challenges and provide optimal solutions worldwide.

We, the Mitsubishi Electric Group, will continue to evolve in "carbon neutrality" and a "circular economy" by promoting innovation in products and services and providing integrated solutions through our business activities, all in order to realize a vibrant and sustainable society.

Under "Changes for the Better" which reflects the Mitsubishi Electric Group's commitment to "always strive to achieve something better", Mitsubishi Electric FA will expand the value of its products and services in the FA system business by advancing the provision and expansion of integrated solutions under the slogan "Automating the World" for an even better tomorrow. Through automation technology, we aim to contribute to innovation not only in the manufacturing industry but also across society as a whole.

We stand as your partner in shaping a smarter, more efficient, and more sustainable future.



The Mitsubishi Electric Group is actively solving social issues, such as decarbonization and labor shortages, by providing production sites with energy-saving equipment and solutions that utilize automation systems, thereby helping towards a sustainable society.

Lineup	5
Concept	8
Improving productivity	10
Sequence + Motion + Network	
Improving program development efficiency	24
One-tool engineering	
Reducing the machine management cost	31
Maintenance	
Digital transformation in factories	40
Security/information linkage	
Digital transformation	
Basic system configuration (MX-R model)	52
Basic system configuration (MX-F model)	54
List of CC-Link IE TSN connection devices	56
Servo system compatible with MELSEC MX Controller	58
Specifications/Function list	61
Product list	66
Support	74

MELSEC MX Controller

MX = Manufacturing transformation



Series product lineup

Mitsubishi Electric programmable automation controller **MELSEC MX Controller**

Mitsubishi Electric
micro programmable controller

MELSEC iQ-F
series



Mitsubishi Electric
programmable controller

MELSEC iQ-R
series



MELSEC MX Controller lineup

The MELSEC MX Controller integrates three types of control, sequence, motion, and network.

The MELSEC MX Controller has two models: MX-R model and MX-F model.

A diversified and sophisticated system can be constructed by using the MX-R models with the MELSEC iQ-R Series modules, and the MX-F models with the MELSEC iQ-F Series modules.

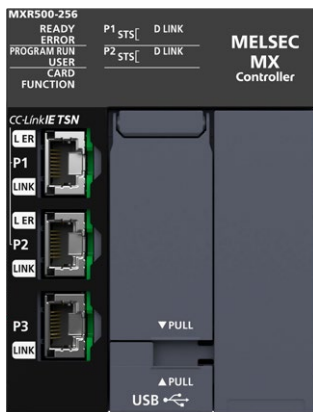

MX-R model*1

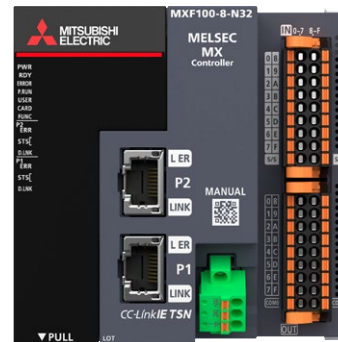

MX-F model

Model	Number of controllable axes (Real drive axes)
CC-Link IE TSN compatible	
➤ MXR300-16	16 axes
➤ MXR300-32	32 axes
➤ MXR300-64	64 axes
➤ MXR500-128	128 axes
➤ MXR500-256	256 axes

Model	Number of controllable axes (Real drive axes)
CC-Link IE TSN compatible	
➤ MXF100-8-□32*2	8 axes
➤ MXF100-16-□32*2	16 axes
EtherCAT compatible*3*4 NEW	
➤ MXF100-8-N32-EC	8 axes
➤ MXF100-16-N32-EC	16 axes

*1: A base unit and power supply module of the MELSEC iQ-R Series are required. For details, refer to P.52.

*2: □ is either N: transistor output (sink) or P: transistor output (source). For details, refer to P.66.

*3: Source type will be supported in the future

*4: For details on MXF100-8-N32-EC and MXF100-16-N32-EC, refer to "Programmable Automation Controllers MELSEC MX Controller" (L(NA)0810011ENG).



One controller for all your control needs

Decades of expertise in programmable controller technology have been combined into a single controller. By integrating sequence control, motion control, and network control on the MELSEC MX Controller platform, faster and more accurate control is achieved.

We will continue to add functionality to this platform, making it adaptable to a wide range of applications.

Equipped with a high-performance multi-core MPU as standard, enabling high-speed control

All functions of sequence, motion, and network are integrated. The motion control performance is **about 10 times**^{*1} higher than existing products of Mitsubishi Electric, achieving high-speed and highaccuracy motion control.

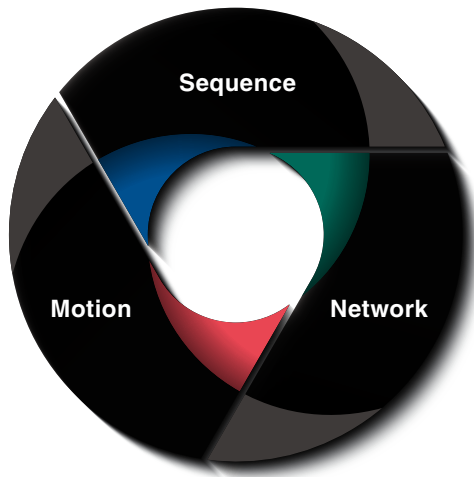

Compatible with multi-axis machines

Number of controllable axes (real drive axes)

MX-R
 Maximum **256** axes

MX-F
 Maximum **16** axes

Increased number of connectable stations

Number of devices connectable to CC-Link IE TSN

MX-R
 Maximum **253** stations^{*2}

MX-F^{*3}
 Maximum **46** stations

Achieving high-speed motion performance

Motion control performance

MX-R
 Maximum **128** axes/1.2 [ms]^{*4}
 Including program execution

MX-F
 Maximum **16** axes/0.5 [ms]

Greatly enhanced compute capability

Double-precision floating-point processing

MX-R
 Maximum **0.46** ns or faster

MX-F
 Maximum **2.50** ns or faster

LD instructions

MX-R
 Maximum **0.28** ns or faster

MX-F
 Maximum **1.25** ns or faster

*1: Comparison with the MELSEC iQ-R Series (64-axis control)

*2: Device stations supporting connections to 253 stations will be available in the future. For details, refer to the Technical Bulletin (FA-A-0451).

*3: For MXF100-8-N32-EC and MXF100-16-N32-EC, the maximum number of devices connectable to EtherCAT of 72 stations applies instead.

*4: When the motion operation cycle setting is 1.5 ms



Improving productivity

Sequence + Motion + Network



Are you facing these challenges?

- Large system size with insufficient CPU performance
- Lack of synchronization accuracy at high speeds
- Need to customize equipment for specific applications



Achieve multi-axis machine control with one controller
P.10



Improving program development efficiency

One-tool engineering



Are you facing these challenges?

- Want to program in different languages to suit regional preferences or team members
- Large projects or equipment prone to bugs
- Long commissioning time due to equipment size



Reduce programming time and streamline development with one-tool engineering and intuitive operation
P.24



Reducing the machine management cost

Digital transformation in factories

Maintenance

Security/information linkage

Digital transformation



Are you facing these challenges?



Are you facing these challenges?

- Quickly recover from equipment failures
- Reduce equipment replacement costs

- Protect assets from cyberattacks
- Easily connect data between IT systems and devices
- Advance front-loaded design with simulations



Significantly reduce downtime with visibility into issues
P.31

Achieve centralized management and sharing of valuable data
P.40
Mitsubishi Electric's Digital Twin
P.46

Improving productivity

Sequence + Motion + Network



Achieve multi-axis machine control with one controller

The MX Controller, equipped with a high-performance multi-core MPU as standard, integrates sequence, motion, and network control, supporting up to 256 axes. It supports mixed operation cycles, ensuring high-speed control even with multiple axes. One controller delivers precise control of individual mechanisms and control of the entire production line.

Achieving high-speed and high-accuracy motion control

MX-R
MX-F

Multi-core MPU

A high-speed multi-core MPU significantly increases processing performance, including double-precision floating-point operations. Inter-core communication allows multiple cores to perform different tasks simultaneously, enabling parallel high-speed sequence, motion, and network control. Distributed control across cores shortens the overall production cycle.

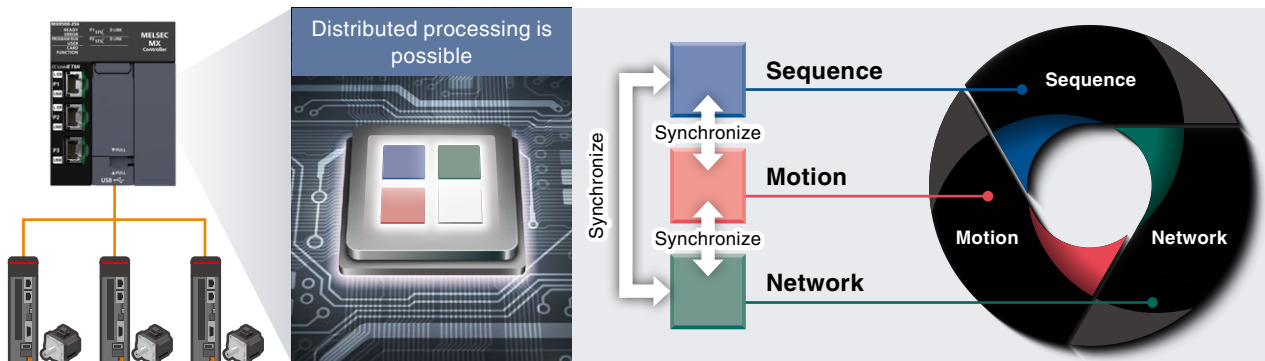

Core load can be monitored and adjusted for optimal machine control

The performance monitor visualizes the operation cycles and load status for each core assigned to run the program. Optimize performance by distributing load through mixed operation cycles based on visualized load status.

Program example

Item	Without load distribution	With load distribution
System configuration	One MXR500-□ + 98 axes of MR-J5	
Setting of the number of axes and operation cycle	98 axes (Operation cycle set to 250 μs)	High-speed axes: 4 axes (set to 250 μs) Low-speed axes: 94 axes (set to 4000 μs)

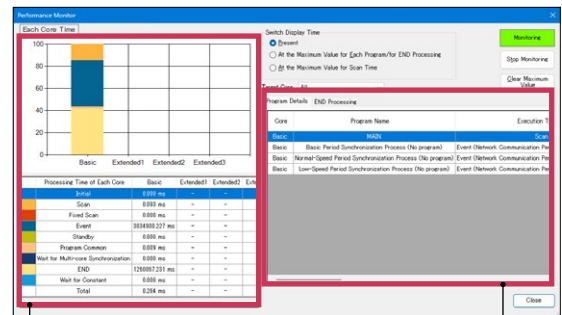

Graphical display of the breakdown of scan times and operation cycles¹ for each core, making even complex tasks easy to understand.

Detailed program information and END processing breakdowns for each core

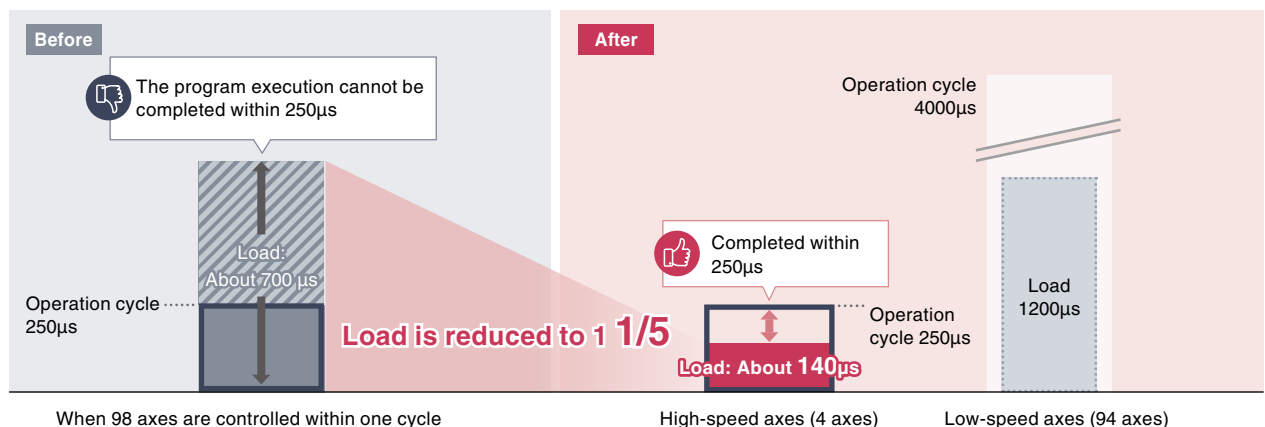

¹: Future support

Achieve synchronous control of sequence and motion effortlessly **NEW**

MX-R
MX-F

Integrating sequence, motion, and network control into MPU cores eliminates control delays and variations. Additionally, up to three types of motion operations with different cycle times (low, medium, and high speeds; minimum 125 μ s) can be constructed independently of the scan execution type program. Internal data, such as axis positions, is synchronized between the motion and sequence controls. This eliminates the need for refresh settings or interrupt instructions between these controls, even on machines with a large number of axes that require the exchange of large volumes of data.

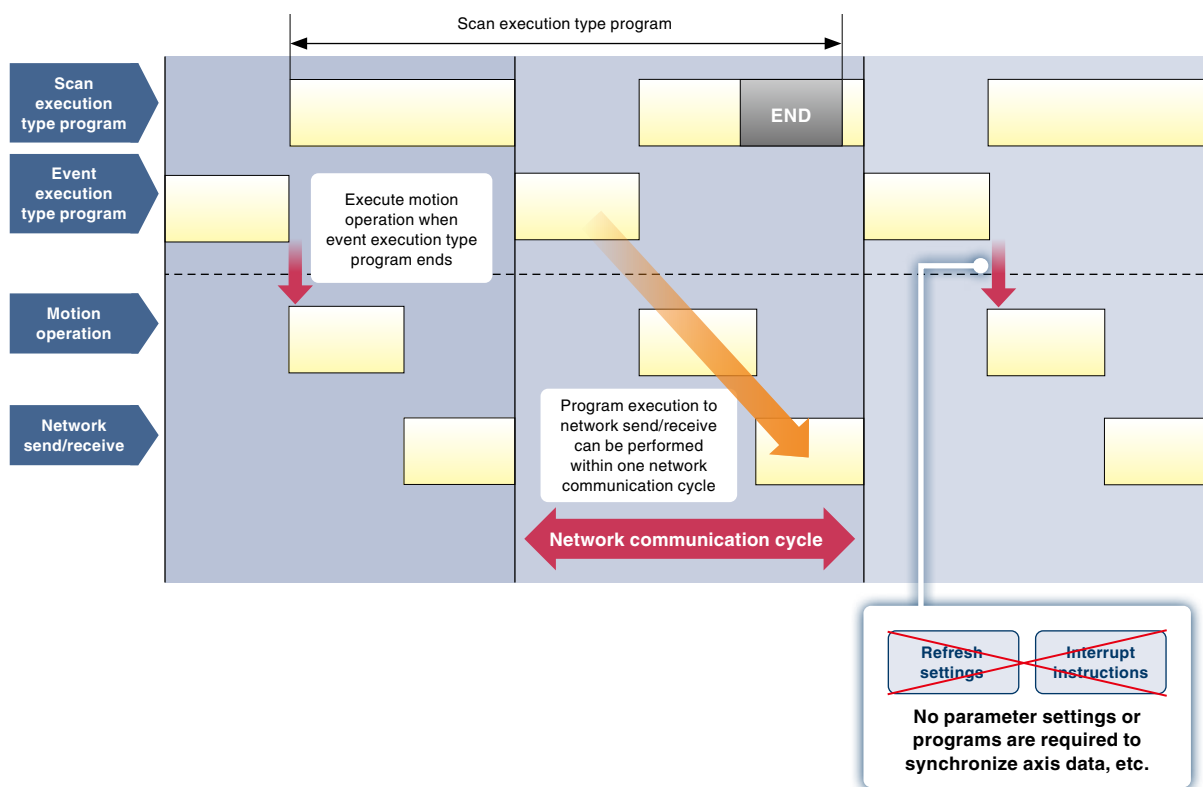

Essential CC-Link IE TSN technology for large-scale equipment

MX-R
MX-F¹

High-speed and high-accuracy coordination with a wide range of devices

CC-Link IE TSN uses TSN² technology to enable the coexistence of control and information communications. This technology allows you to build a system that integrates real-time control communications for factory automation equipment and IT system information communications with just one MELSEC MX Controller.

» What is TSN?

TSN is a set of international standards, which define the time synchronization method and the time sharing method. By adding these to Ethernet technology, control communications (ensuring real time reaction), which cannot be performed with conventional Ethernet, and information communications (non-realtime communications) can be performed together.

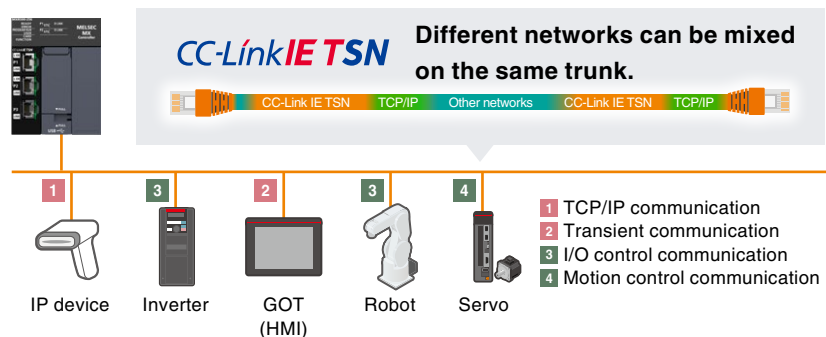

The CC-Link IE TSN time sharing method enables communications independent of the number of device stations

The time sharing method used as the communications protocol allows simultaneous input and output communication between connected stations. The efficient CC-Link IE TSN protocol combined with the MELSEC MX Controller's high-speed link scan substantially reduces cycle times. Mixed communication cycles are also possible, ensuring fast and smooth communication even with many device stations.

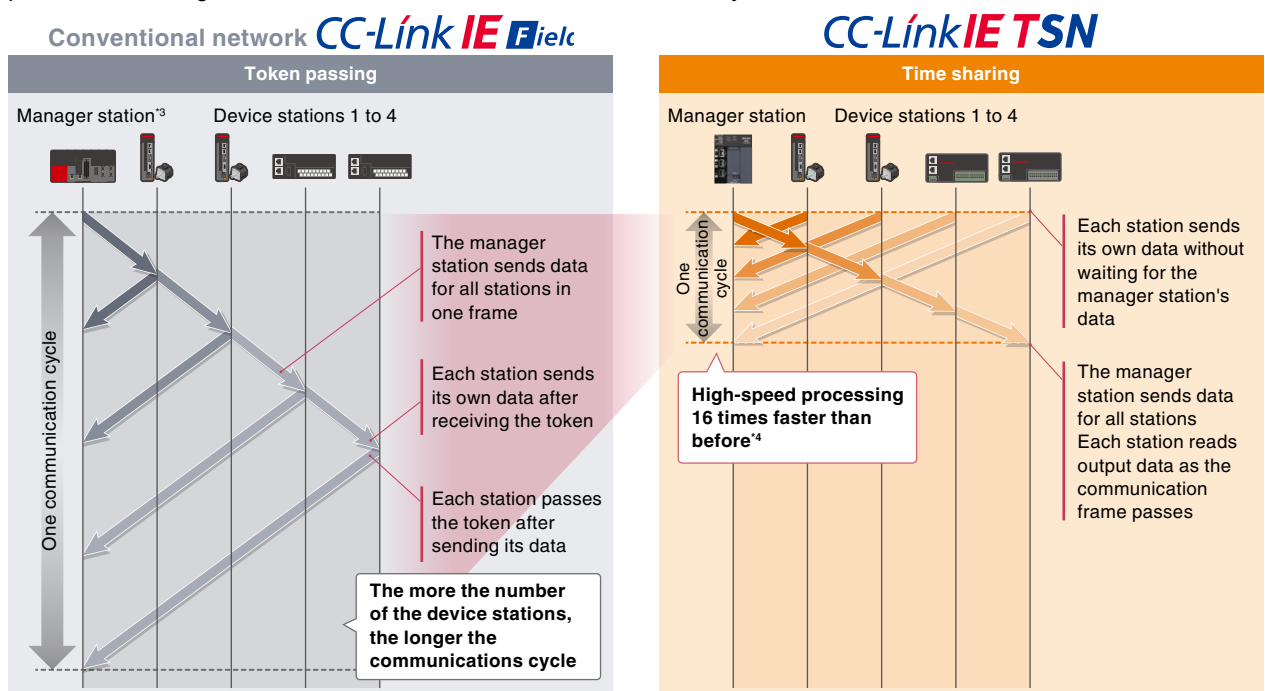

*1: MXF100-8-N32-EC and MXF100-16-N32-EC are not supported.

*2: Time-Sensitive Networking

*3: In this catalog, the term "manager" (manager station), as used by the CC-Link Partner Association, may be referred to as "master" (master station).

*4: Under the same conditions

Optimizing control performance of entire system

MX-R
MX-F¹

With one MELSEC MX Controller, up to three different operation and communication cycles can be set for each axis and device station.²

There is no need for multiple CPU modules. This greatly improves the cost efficiency of your equipment. Even for multi-axis machines, the control performance at high-speed operation cycles can be partially secured, improving accuracy in processes such as cutting.

Three types of operation cycles can be mixed

Mixing motion control operation cycles distributes the core load, reducing the processing burden of motion control.

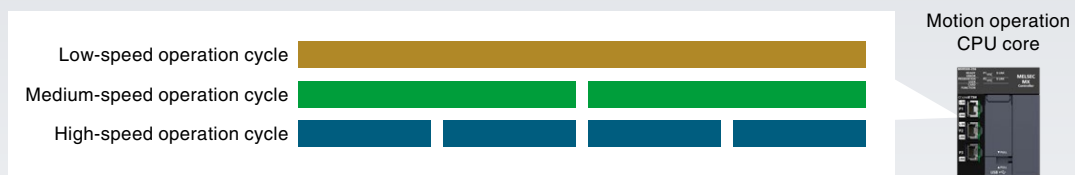
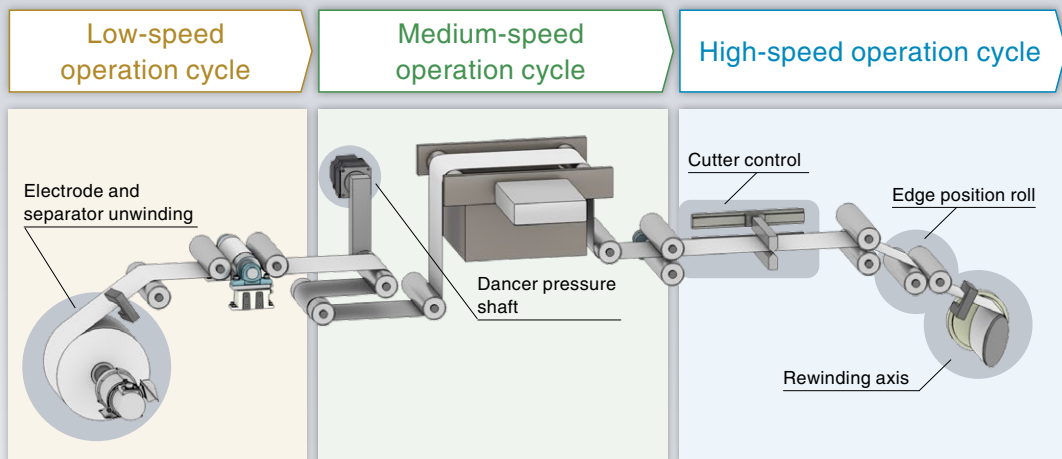

Since refresh timings for sent/received data can be mixed, even when devices with different communication cycles coexist, high-speed communication devices can communicate without being affected by low-speed communication devices.

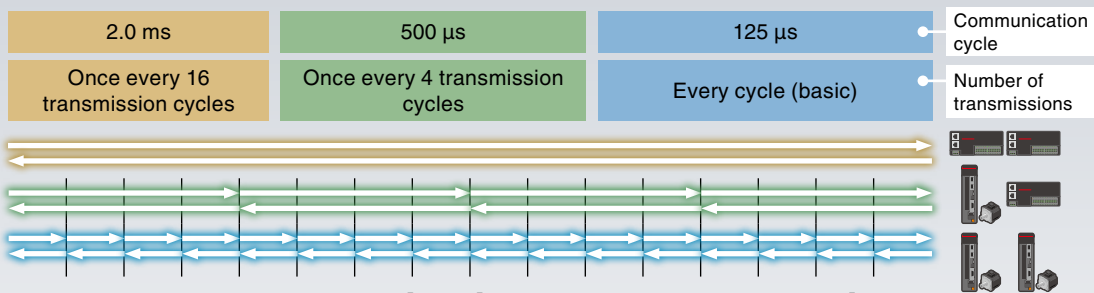

Three types of communication cycles can be mixed

CC-Link IE TSN

¹: MXF100-8-N32-EC and MXF100-16-N32-EC are not supported.

²: Using GX Works3, you can set communication cycles in the CC-Link IE TSN configuration setting window and operation cycles in the axis parameter settings.

Wireless communication for control and TCP/IP communications **NEW**

MX-R
MX-F^{*1}

Wireless communication is possible for both control communication (general and safety^{*2}) and information communication via CC-Link IE TSN Class A.

Using wireless communication enables flexible system configuration.

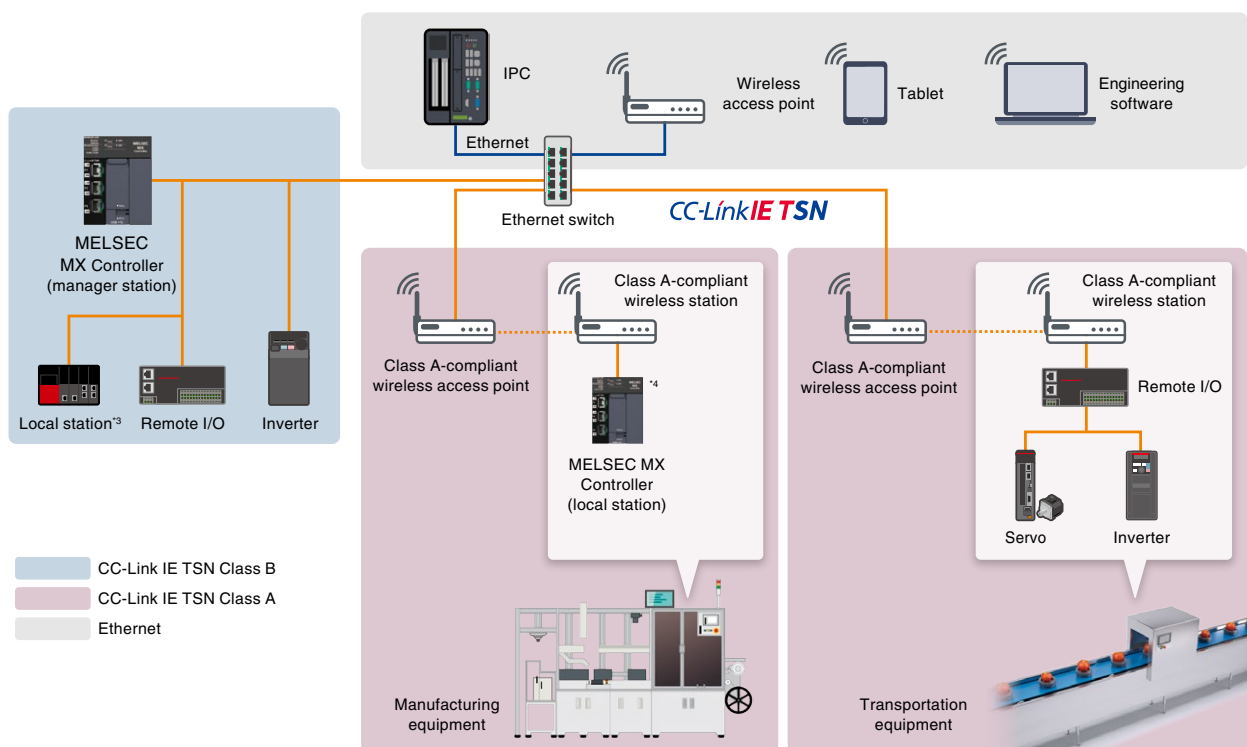

*1: MXF100-8-N32-EC and MXF100-16-N32-EC are not supported.

*2: Future support.

*3: Connectivity with local stations when the MX Controller is configured as a manager station will be supported in the future.

*4: CC-Link IE TSN Class A communication as a local station will be supported in the future.

Precise mark input and cutting not dependent on scan time

MX-R
MX-F¹

Even in applications that require high-speed I/O control without variability, such as roll-to-roll control, the MX Controller provides precise I/O over the network that is not dependent on the scan time. Minimized jitter in the I/O timing of mark detection and cutting reduces variations in web material detection and cut length. This improves yield in high-speed production lines.

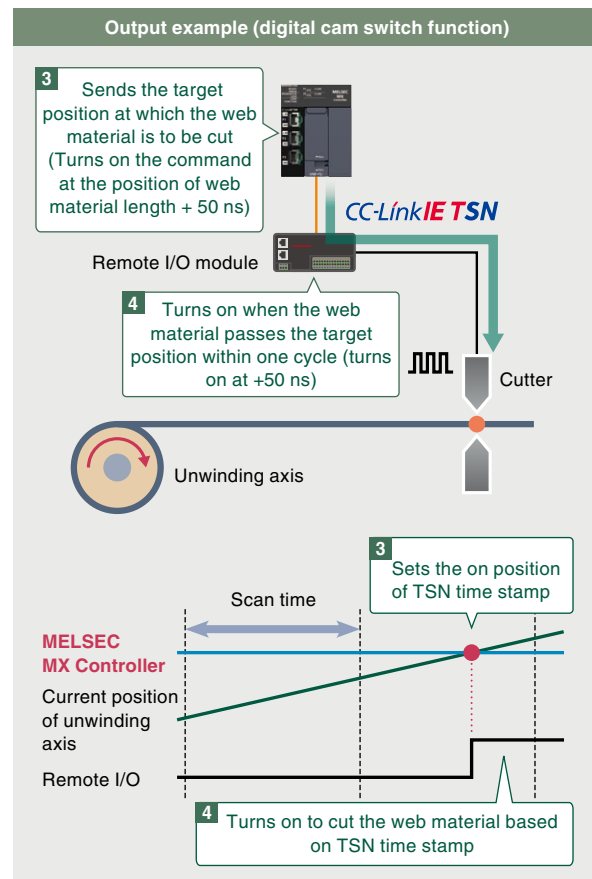
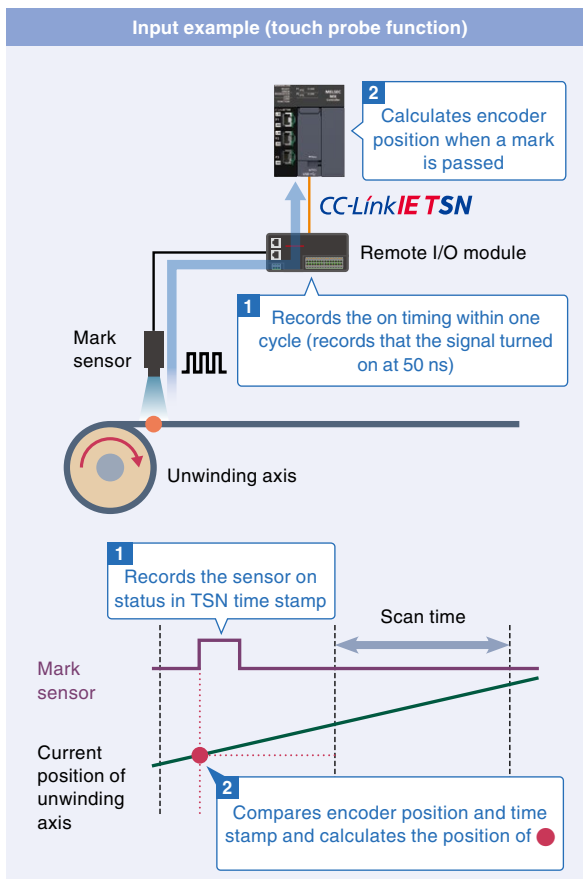
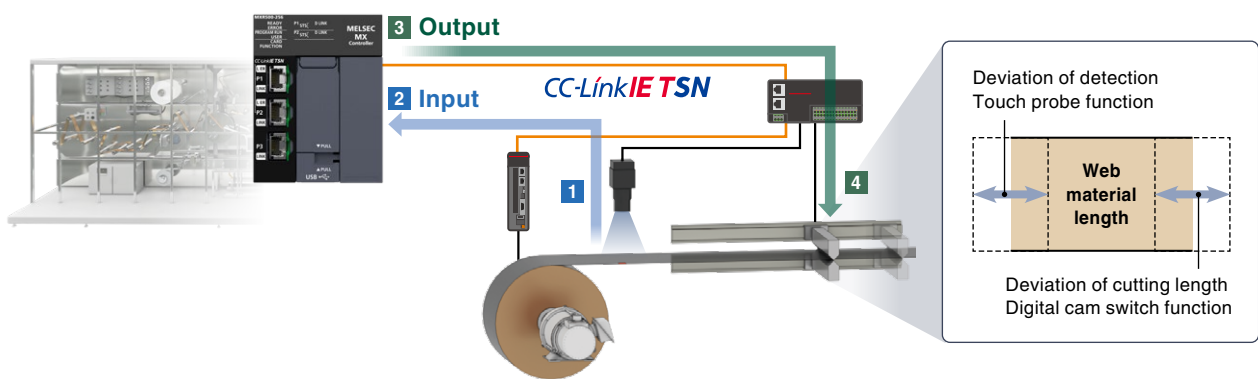

Control in the units recorded in the CC-Link IE TSN network time stamp (in units of ns) is possible.²

¹: MXF100-8-N32-EC and MXF100-16-N32-EC are not supported.
²: The actual I/O timing varies depending on the device used.

Intuitive operation with visual data

The digital cam switch settings can be configured using GX Works3.

You can easily set the position and I/O output timing by manipulating the on-screen graph with the mouse.

Furthermore, since no adjustments to the timing output calculation according to position or the interrupt instructions are needed even if the motor speed fluctuates, engineering effort can be reduced.

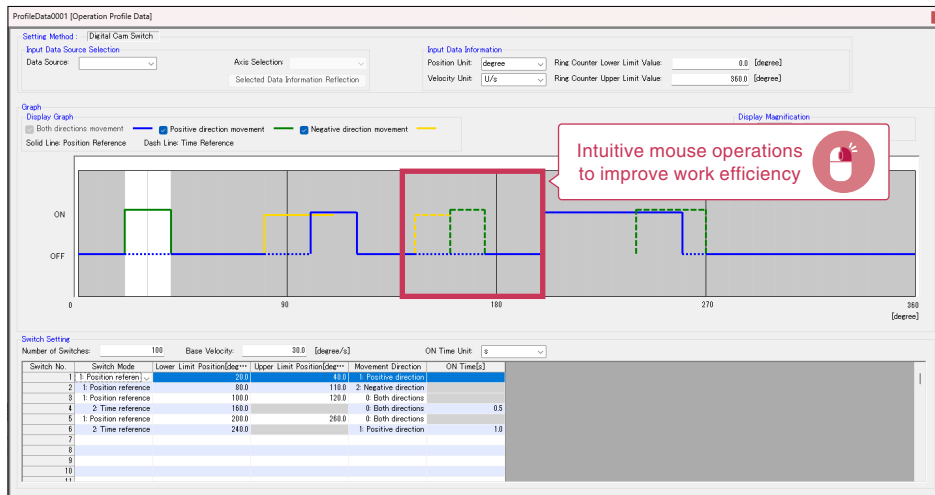

64-bit-compatible and highly accurate control

64-bit control minimizes rounding errors during calculations, ensuring highly accurate control.

Positioning range and resolution

Compared to 32-bit control, 64-bit control offers a broader positioning range while maintaining high resolution.

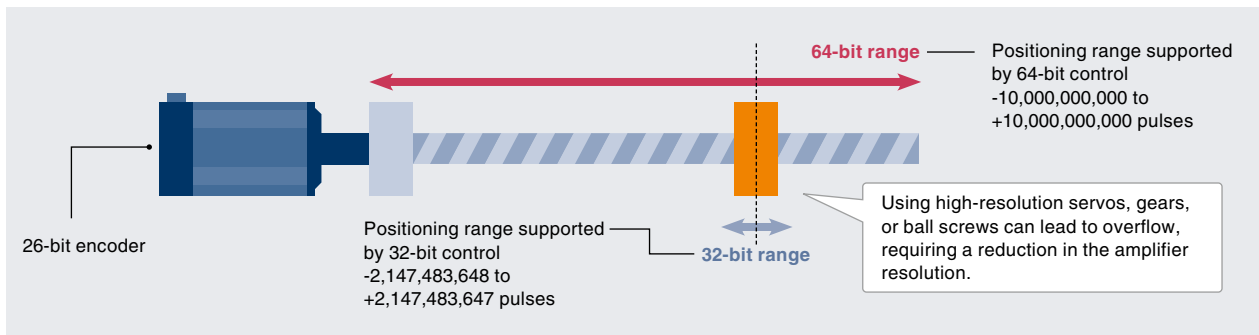

Absolute position control system and current position restoration

The MELSEC MX Controller performs 64-bit absolute position control, significantly reducing the risk of current position restoration error after poweroff.

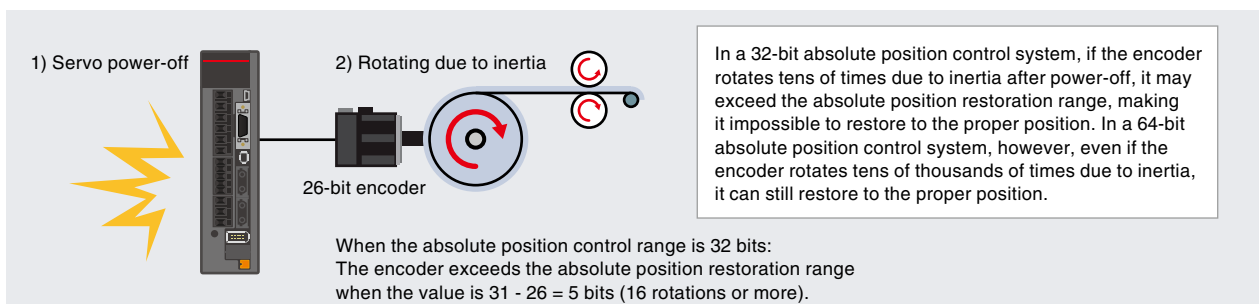

Global motion programming styles in one product

The MELSEC MX Controller supports multiple motion programming styles, allowing you to fully leverage its performance and functionality in a familiar way.

Programming using PLCopen® Motion Control FB

MX-R
MX-F

Programming using internationally standardized PLCopen® Motion Control FB library is available. This standard enables engineers worldwide to develop using common specifications, streamlining development and maintenance across global locations. It allows for highly readable programming through the use of function blocks, structured text (ST), and labels.

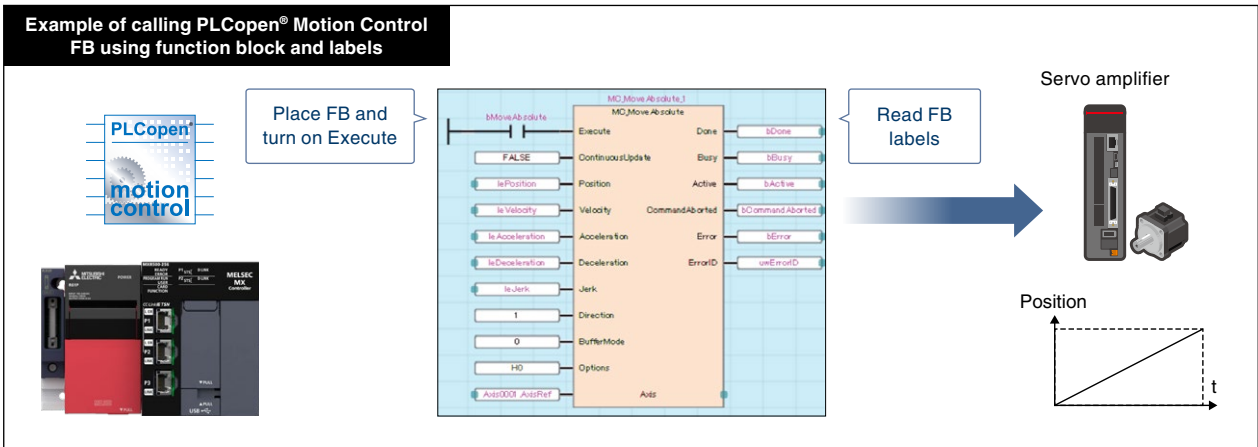

Programming using device address-based motion control

Future support
MX-R
Future support
MX-F

Device address-based motion control programming, which allows for execution by simply writing data to buffer memory access devices, is available. This provides engineers skilled in ladders and device manipulation with a familiar programming environment. Instructions for new functions can also be called from the buffer memory.

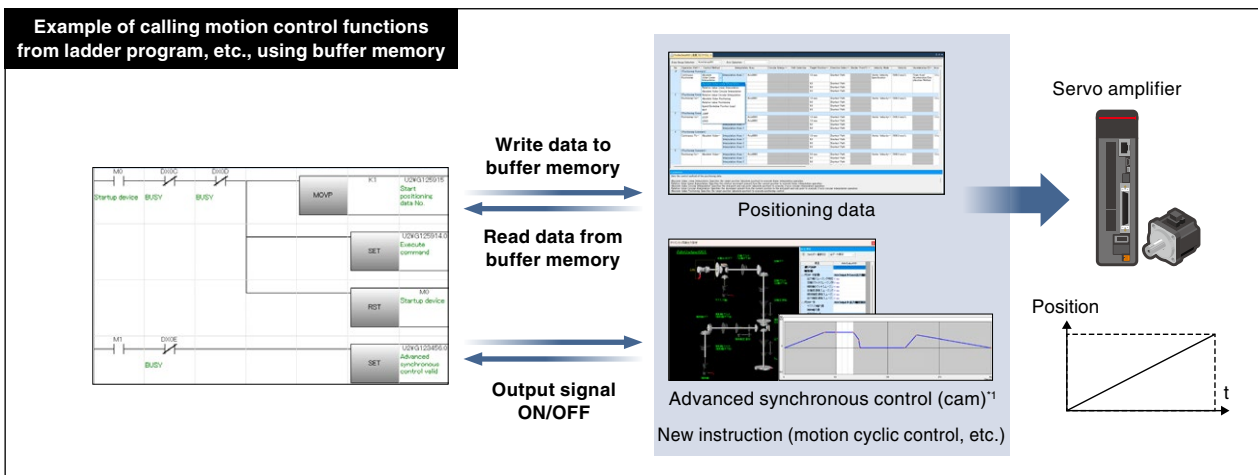

*1: Device address-based motion control can be mixed with PLCopen® Motion Control FB and FB library. Up to 128 axes can be controlled by device address-based motion control. Advanced synchronous control and buffer memory addresses for some instructions will be supported in the future.

Utilizing program assets NEW

MX-R
Future support
MX-F

Program assets from the MELSEC iQ-R Series, such as parameters, can be reused on the MELSEC MX Controller.^{*1}

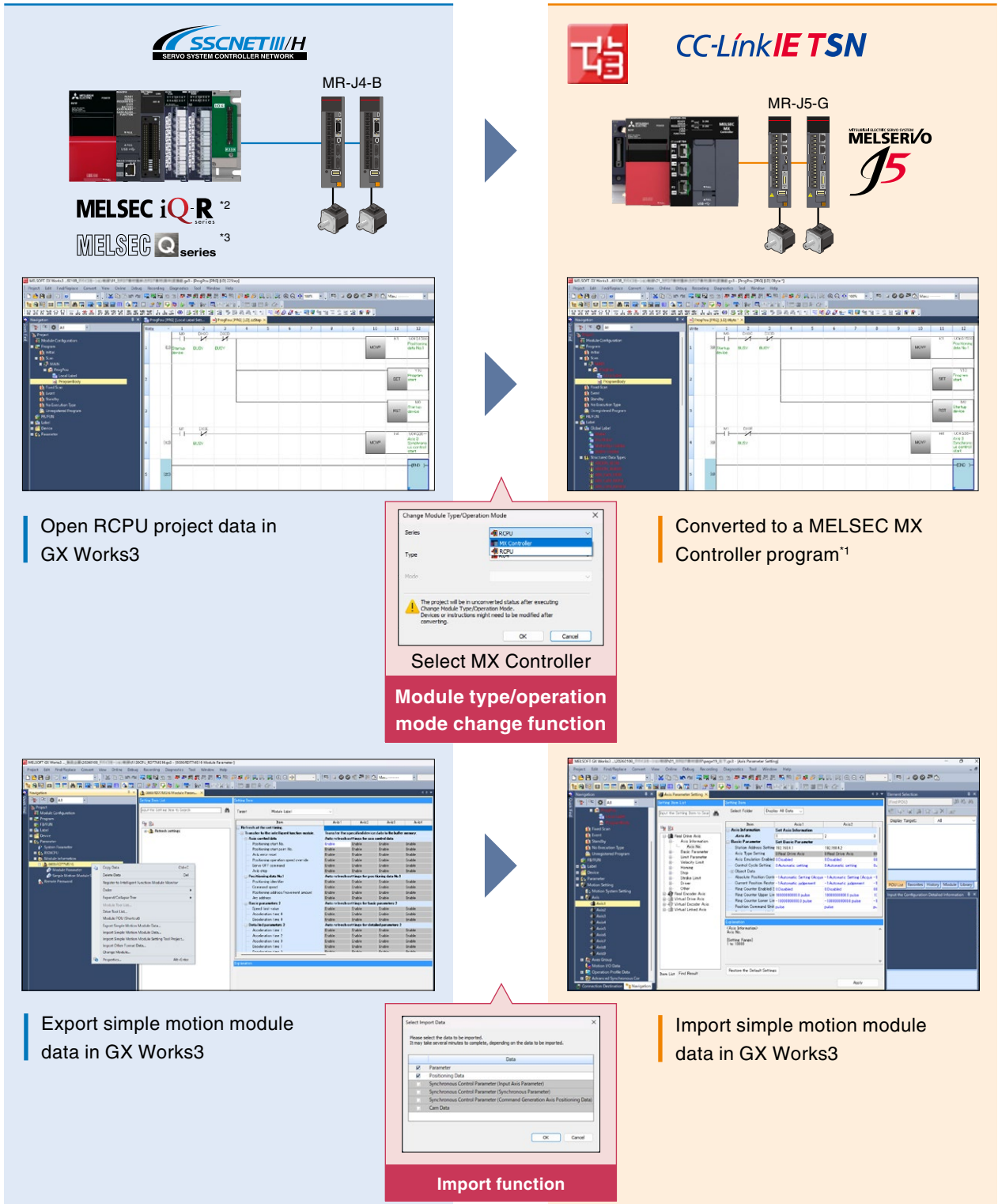

*1: Some functions, such as program buffer memory addresses, will be supported in the future (a migration guide will also be published).

*2: Applicable models are RD77MS, RD77GF, and RD78G(S). The reuse function for RD78G will be supported in the future.

*3: For QD77MS, phased migration via RD78G is required. Refer to "Migration Guide from QD77MS Simple Motion Module to RD78G Motion Module (Simple Motion Mode)" (SSC-A-0004) for information on migration to RD78G.

Optimize multi-axis system with graphical user interface

MX-R
MX-F

Advanced synchronous control^{*1}

Software replaces machinery mechanisms (such as gears, shafts, speed change gears, and cams) for easier synchronous control.

Even for machines that require multi-axis synchronization, such as winders and coaters, it is easy to adjust the cam control and operation speed pattern to eliminate position deviation. Fine-tuning the cutting position and adjusting the synchronization position according to the transportation speed can achieve high quality and high productivity.

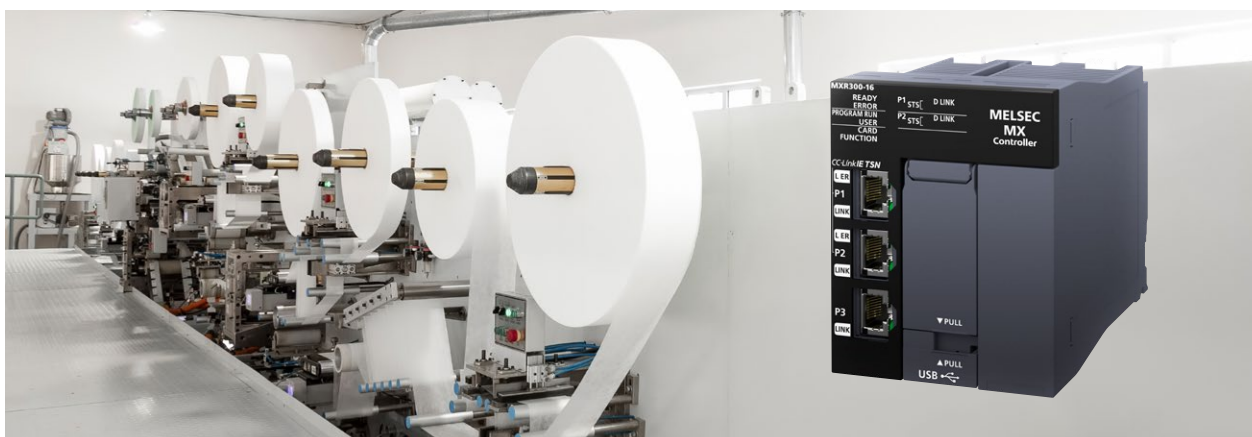

Synchronous control parameters

The intuitive visual interface makes it easy to create cam data and configure parameters. This enables low-code development of complex multi-axis synchronization programs, significantly increasing work efficiency.

Cam data (operation profile data) setting window^{*2}



*1: Motion control FBs are used.

*2: Calls from PLCopen[®]-compliant MC CamIn instructions are also supported.

Visually intuitive positioning settings NEW

MX-R

MX-F¹

Positioning data operation

Positioning data (point tables) can be configured using GX Works3.

With extensive controls, including linear and 2-axis circular interpolation and single-axis positioning¹, it can be used for a wide range of applications.

Rich auxiliary functions, such as M-code and skip functions, meet customer needs.

Sealing

- Continuous path control
- Linear/circular interpolation
- Synchronous control
- High-speed, high-accuracy path calculation

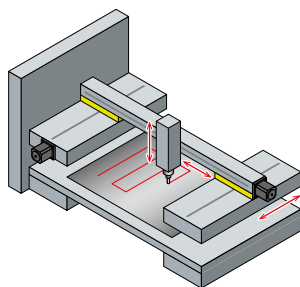

X-Y table

- 2-axis linear interpolation
- 2-axis circular interpolation
- 3-axis linear interpolation
- Continuous path control

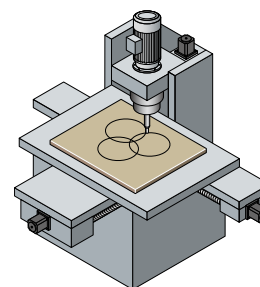

No.	Operation Pattern	Control Method	Interpolation Axes	Circular Interpo...	Path Selection	Target Position...	Direction Selec...	Border Point/C...	Velocity Mode	Velocity	Accelerati...
1	<Positioning Comment> Continuous Positioning	Absolute Value Linear Interpolation	Interpolation Axes 1 Interpolation Axes 2 Interpolation Axes 3 Interpolation Axes 4	Axis0001 Axis0002 Axis0003 Axis0004		10000.0 pulse 10000.0 pulse 10000.0 pulse 10000.0 pulse	Shortest Path Shortest Path Shortest Path Shortest Path		Vector Velocity...	1000.0 pulse/s	Time-fixed
2	<Positioning Comment> Continuous Positioning	Relative Value Linear Interpolation	Interpolation Axes 1 Interpolation Axes 2 Interpolation Axes 3 Interpolation Axes 4	Axis0001 Axis0002 Axis0003 Axis0004		20000.0 pulse 20000.0 pulse 20000.0 pulse 20000.0 pulse			Vector Velocity...	2000.0 pulse/s	
3	<Positioning Comment> Continuous Positioning	Absolute Value Circular Interpolation	Interpolation Axes 1 Interpolation Axes 2	Axis0001 Axis0002	Border Point S...	30000.0 pulse 30000.0 pulse		0.0 pulse 0.0 pulse		3000.0 pulse/s	
4	<Positioning Comment> Continuous Positioning	Relative Value Circular Interpolation	Interpolation Axes 1 Interpolation Axes 2	Axis0001 Axis0002	Border Point S...	40000.0 pulse 40000.0 pulse		0.0 pulse 0.0 pulse		4000.0 pulse/s	
5	<Positioning Comment> Continuous Positioning	Absolute Value Positioning				50000.0 pulse	Shortest Path			5000.0 pulse/s	
6	<Positioning Comment> Continuous Positioning	Relative Value Positioning				60000.0 pulse				6000.0 pulse/s	
7	<Positioning Comment> Positioning Complete	Speed (Including Position Loop)						Positive Direction		7000.0 pulse/s	
8	<Positioning Comment> NOP										
9	<Positioning Comment> JUMP										
10	<Positioning Comment> LOOP										
11	<Positioning Comment> LEND										
F2	<Positioning Comment>										

- Execution from FB or buffer memory² is possible
- Positioning data can be set at once in a dedicated window
- Complex positioning control can be implemented by creating multiple operation patterns

¹: Single-axis positioning data for MX-F model will be supported in the future.

²: Future support.

Develop more advanced control loops

MX-R
MX-F

Motion cyclic control

- The MX Controller supports motion cyclic control, allowing the transmission of target torque, position, and speed with each operation cycle, in addition to standard positioning operation.
- Setting the task type to "network communication cycle synchronization" ensures deterministic performance from programmable controller tasks to network transmission.
- The floating-point operation performance is improved by about 15 times^{*1}.



These allow program execution, motion operation, and network send/receive to be performed within the same communication cycle. This makes it possible to implement advanced control loops that generate control commands from the user program in real time and instantly transmits sensor values to drives.

Before Conventional position control

Only positioning in predefined operation patterns can be performed.

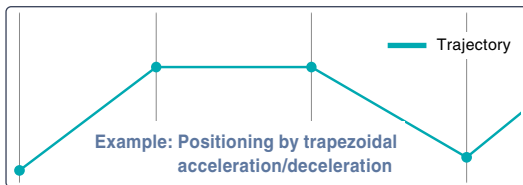

After Motion cyclic control

Servos can be controlled by feed back control programs linked to external sensors.



Example



Application example

Position control

Robot (coordinate transformation), camera stage correction, and others

Speed control

Tension feed back and others

Torque control

Feed back control by pressure or external encoder and others

» **Advanced applications can be achieved**

- High-speed real-time feed back control
- Deterministic data transfer is ensured from program execution to data transfer to the servo.
- Computational operation using the floating-point can be easily performed.

Achieve real time control

Punctuality from input to data transmission over the network is assured using network communication cycle synchronization tasks.

*1: Comparison with the MELSEC iQ-R Series
*2: The maximum operation cycle for an MX-F model is 250 µs.

Achieve high-speed, high-response, and stable pressure control

MX-R
Future support
MX-F

The analog signal from a pressure sensor (load cell^{*1}) is input to the MR-J5-G-LL to control the pressure. The pressure can be kept constant even while the load is changing. High-response pressure control is possible by applying a pressure model to reduce over-pressing.

Example of pressure control

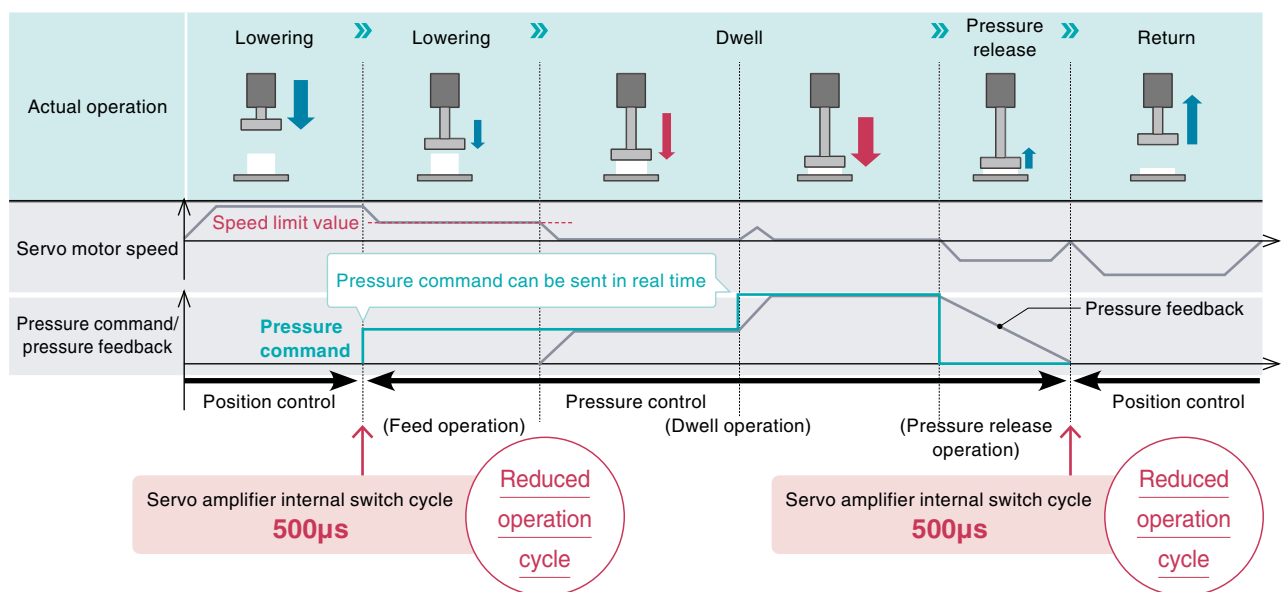

Supporting applications with high real-time reaction

By combining the MX Controller with the MR-J5-G-LL, which supports cyclic pressure control mode (csp), the servo amplifier performs feedback control of pressure according to the pressure command of the function block. The pressure control loop operates independently of the controller, achieving high-speed and high-response control.

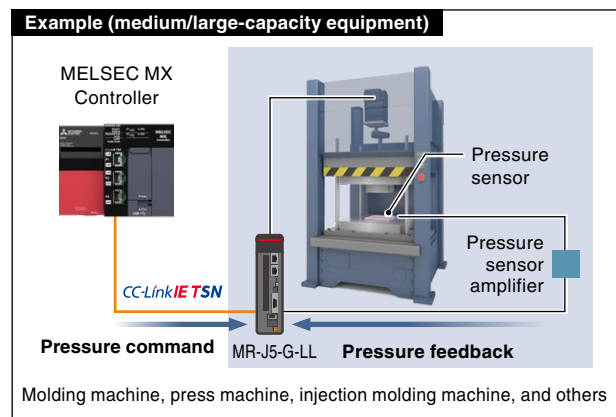
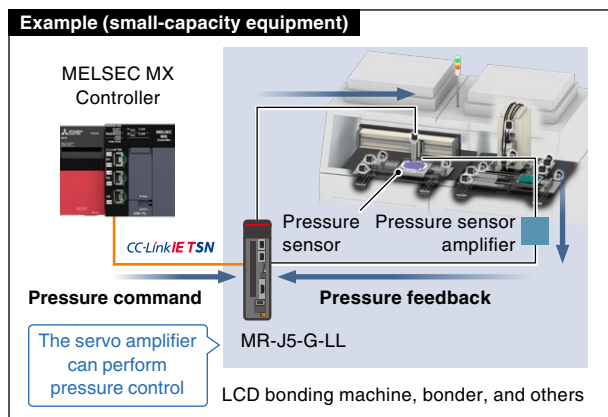

High-accuracy and stable pressure control can be achieved.

*1: A force sensor that enables force measurement by converting force into an electrical signal

Improving program development efficiency One-tool engineering

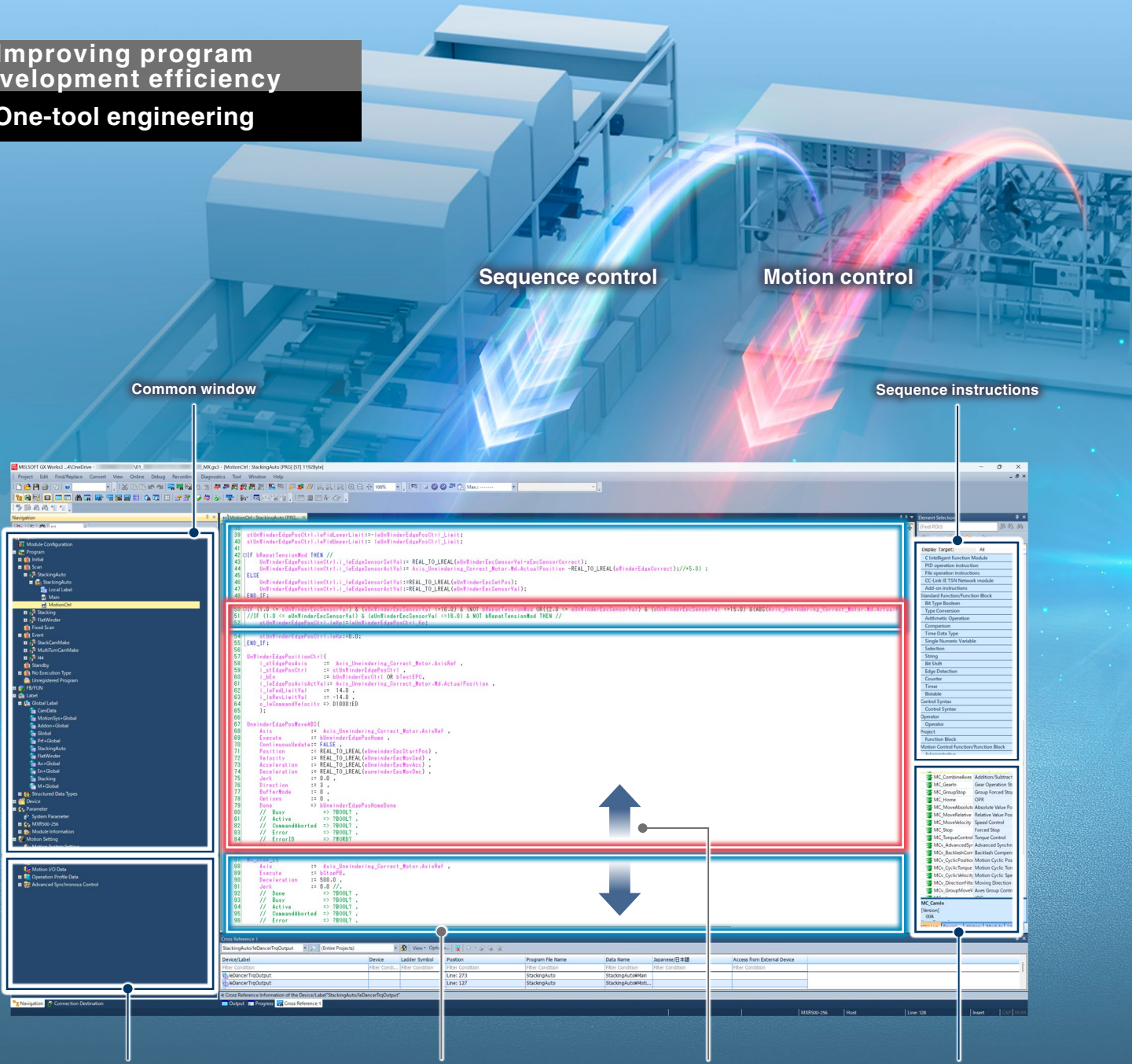

Motion setting window

Sequence program and motion program can be mixed

No refresh between sequence program and motion program

Motion instructions

Reduce programming time and streamline development with one-tool engineering and intuitive operation

Sequence control and motion control programs are combined into one. There is no need to create separate programs for each module or exchange data, simplifying your programs. With a single tool handling both sequence and motion control programs, you can easily modularize the program into components, manage change history, and debug.

Programming using IEC 61131-3 languages

MX-R
MX-F

Ladder diagram (LD), structured text (ST), and function block diagram (FBD) are supported. Motion control programming also supports LD, ST, and FBD, allowing the use of FBs that conform to the international PLCopen® Motion Control FB standard.



Function block diagram (FBD)

Structured text (ST)

Ladder diagram (LD)

GX Works3



The PLCopen®-compliant Motion Control FB interface is standardized, making it easier for others than the original programmer to understand program content, reducing design and maintenance time.

Reduce programming effort with labels and structures

Improve program readability by managing signals such as sensor signals with labels named according to their role and use.

Using labels allows you to program without worrying about devices used in other programs when creating multiple programs.

» What is a label?

A variable that is used by a program, instead of a device. Label names and data types can be defined optionally according to their role and use. Program readability can be improved by using labels.

	Label Name	Data Type
1	bTransfer	Bit
2	sSensorData	String(32)
3	Start_switch	Bit
4	Stop_switch	Bit
5	In_operation	Bit

Using devices

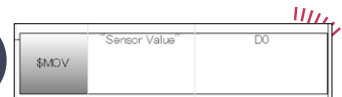

Using labels

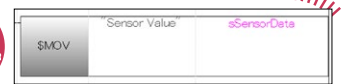

- Duplication of addresses used by devices does not need to be considered.
- The usage of data can be understood from the specified label name even without a comment.
- Changes to a label are reflected in all the same labels, so that working hours can be reduced.

» What is a structure?

A structure unifies labels of multiple types (data types) to define a new data type. Using structures helps arrange and manage data and improves reusability.

Reuse structures to improve work efficiency



• Defining data with only labels

	Label Name	Data Type
1	sensorA.sLabel1	String(32)
2	sensorA.bLabel2	Bit
3	sensorA.wLabel3	Word [Signed]
4	sensorA.wLabel4	Word [Signed]
5	sensorB.sLabel1	String(32)
6	sensorB.bLabel2	Bit
7	sensorB.wLabel3	Word [Signed]
8	sensorB.wLabel4	Word [Signed]



It is difficult to reuse data sets because they are defined in connection devices without being compiled

• Defining members (data) of a structure

	Label Name	Data Type
1	sLabel1	String(32)
2	bLabel2	Bit
3	wLabel3	Word [Signed]
4	wLabel4	Word [Signed]

• Defining the created structure in labels

	Label Name	Data Type
1	sensorA	Sensor_Status
2	sensorB	Sensor_Status

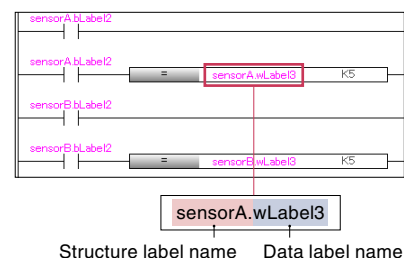

- Data structures can be reused among programs that perform similar processing.
- Structures can also be reused in programs of other machines.

» What is an array?

Data of the same type can be managed by number in an array. You can easily handle large amounts of data by using arrays.

Multiple devices can be used as arrays or structures

The label information (network labels) of devices can be used as bit arrays, structures, and structure arrays, so that programming efficiency can be improved.

1 The label information of a device can be generated as a structure.



FR_E800_E

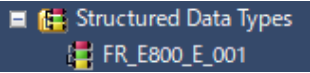

2 The bit string within a device can be generated as an array.

Order	Allocated link device
[0]	RX0
[1]	RX1
[2]	RX2
[3]	RX3
[4]	RX4
⋮	⋮
[15]	RXF

3 Multiple devices can be generated as a structure array.

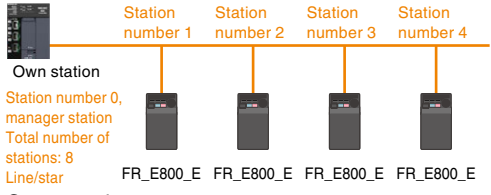

Own station
Station number 0, manager station
Total number of stations: 8
Line/star

FR_E800_E FR_E800_E FR_E800_E FR_E800_E

Generated array

Index number	Allocated device
[0]	FR_E800_E_001
[1]	FR_E800_E_003
[2]	FR_E800_E_004
[3]	FR_E800_E_002

■ Programming, such as index specification, can be performed by specifying an array element in the structure array.

Supporting arrays

By defining elementary data types, structures, and FB types as an array, the same FB can be declared/described at once. The program can be simplified because there is no need to call the same FB again.

Before

	Label Name	Data Type
1	Recipe1	MC_MoveAbsolute
2	Recipe2	MC_MoveAbsolute
3	Recipe3	MC_MoveAbsolute
4	Recipe4	MC_MoveAbsolute
5	Recipe5	MC_MoveAbsolute

```

1 Recipe1(Execute := TRUE) ;
2 Recipe2(Execute := TRUE) ;
3 Recipe3(Execute := TRUE) ;
4 Recipe4(Execute := TRUE) ;
5 Recipe5(Execute := TRUE) ;

```

Each FB declaration requires one row of data

Call processing is complicated
(Program readability decreases/memory usage increases)

MELSEC MX Controller

	Label Name	Data Type
1	Recipes	MC_MoveAbsolute(1..5)

```

1 FOR RecipeNo := 1 TO 5 BY 1 DO
2   Recipes[RecipeNo](Execute := TRUE) ;
3 END FOR ;

```

Simple FB declaration/
program

■ The same FB can be declared/described at once so that programming time can be reduced.

Supporting the label initial value setting in a table format

You can set initial values for array elements and structure instances on the label editor. This eliminates the need for initial value setting programs, reducing the program capacity and the scan time.

	wLabel1[0]	wLabel1[1]	wLabel1[2]	wLabel1[3]
	Word [Signed]	Word [Signed]	Word [Signed]	Word [Signed]
[0]	10	11	12	13
[1]	20	21	22	23
[2]				
[3]				
[4]				

You can create label initial values using Microsoft® Excel® and easily copy and paste them



■ The initial values can be set to array elements, reducing the programming time.

Streamline your project development by modularizing programs into components

Increase program reusability by using label names, FBs, structures, and arrays to modularize a program into components. This approach not only reduces development time but also creates more readable programs. It also ensures consistent programming quality regardless of developer skill level. Each component can be assigned to a specific member, clarifying roles and responsibilities.

Example of combination of labels, FBs, and structures

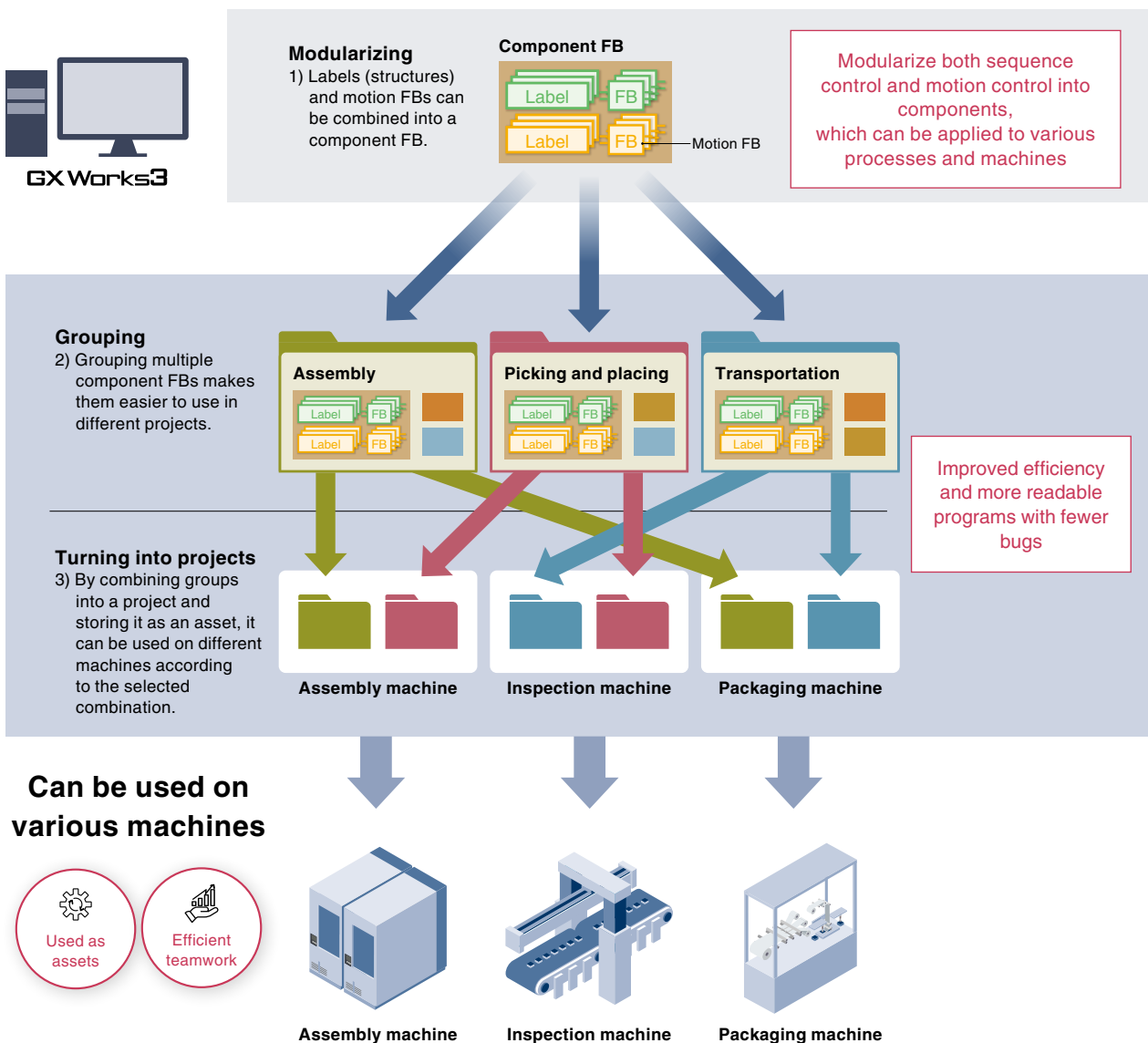

Efficiently develop large-scale projects with multiple members using program configuration management

MX-R
MX-F

Program configuration management enables program reuse and collaboration. Changes made by others are reflected immediately, with centralized history management for easy tracking of changes.

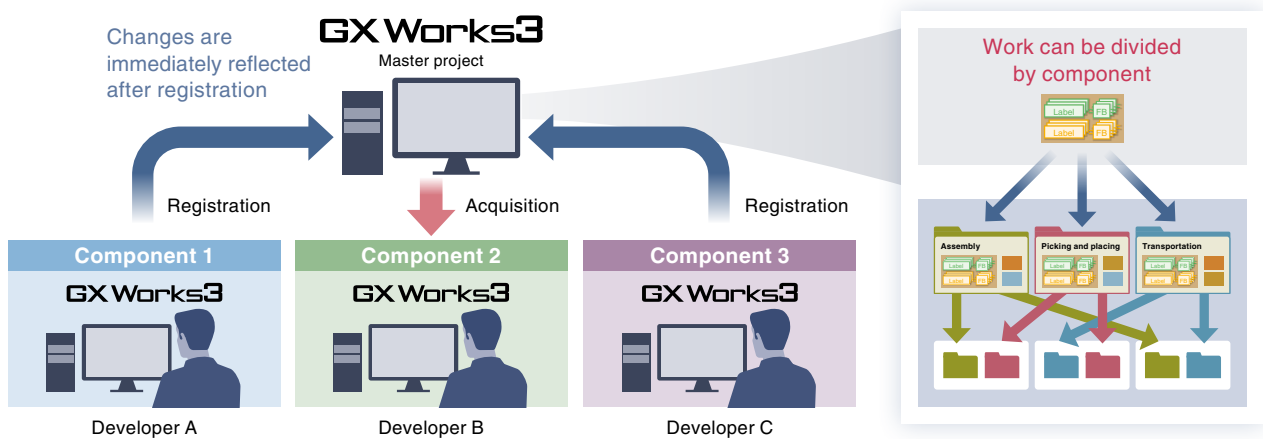

Program history log can be kept

You can track which version caused a machine failure.

• Data registration method

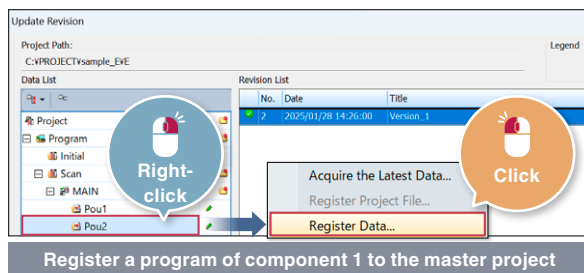

Register a program of component 1 to the master project

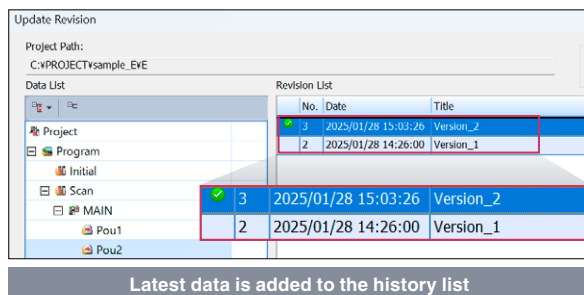

Latest data is added to the history list

- You can track who changed which components and when.
- Edited data is not overwritten by others.

Data can be restored for only a specific part

Sudden machine failures can be responded to quickly.

• Verification method

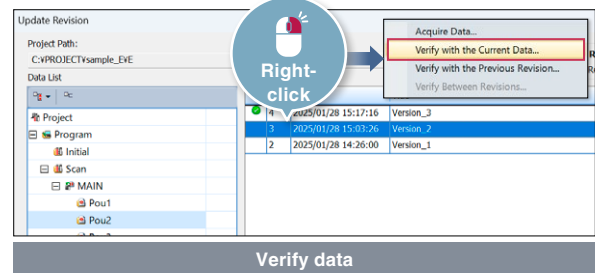

Verify data

• Rollback method

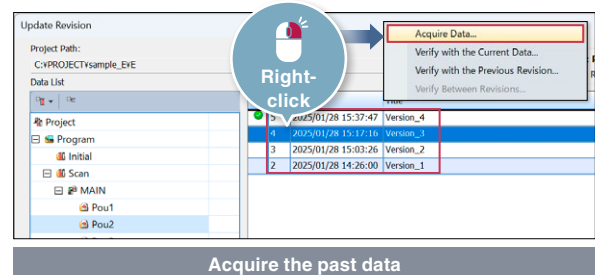

Acquire the past data

The project can be restored to a state before a failure occurred.

Reduce commissioning time for multi-axis machines

Easy axis generation

Real drive axes can be generated from network configuration information. Generating axes based on network configuration settings reduces the time and effort required to set up axes.

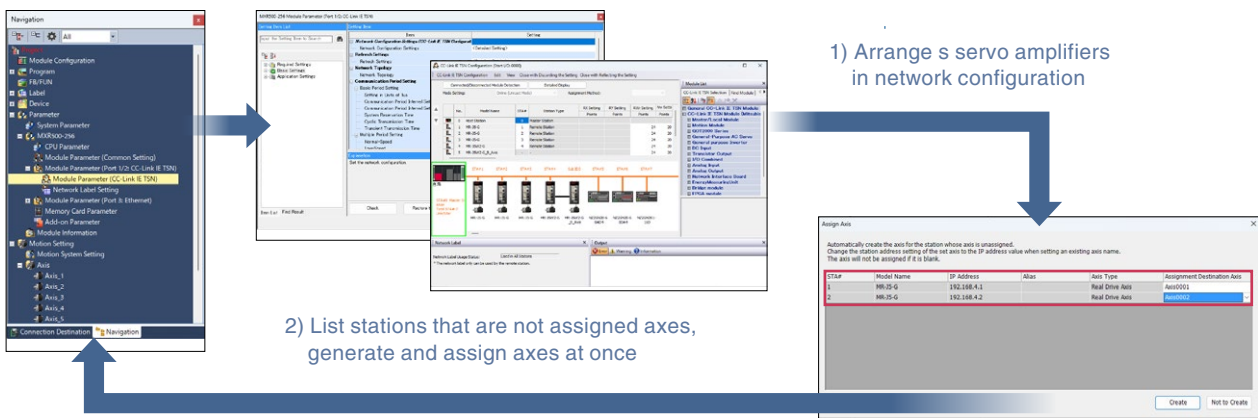

■ Axes can be generated at once for servo amplifiers that are not assigned axes.

Setting IP addresses of axes at once

You can view a list of stations assigned to each axis and change their IP addresses.

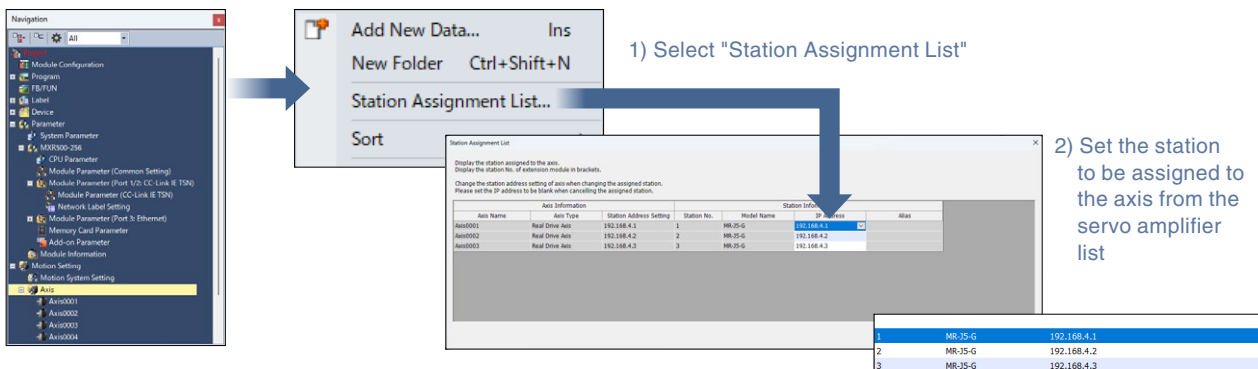

■ The IP address of the station to be assigned to the axis can be set at once.

Reducing the machine
management cost
Maintenance



Significantly reduce downtime with visibility into issues

Achieve speedy root cause analysis through system-wide recording of operational status and extraction of anomalies using AI.

Record system-wide data over the network NEW

MX-R
Future support
MX-F

Workpiece status and operation history are fully recorded along with control data from each equipment and machine before and after a problem occurs.*1

View time-synchronized recorded waveform data, programs and video to easily identify the root cause.

This allows you to quickly and comprehensively investigate the cause and prevent problems from recurring.

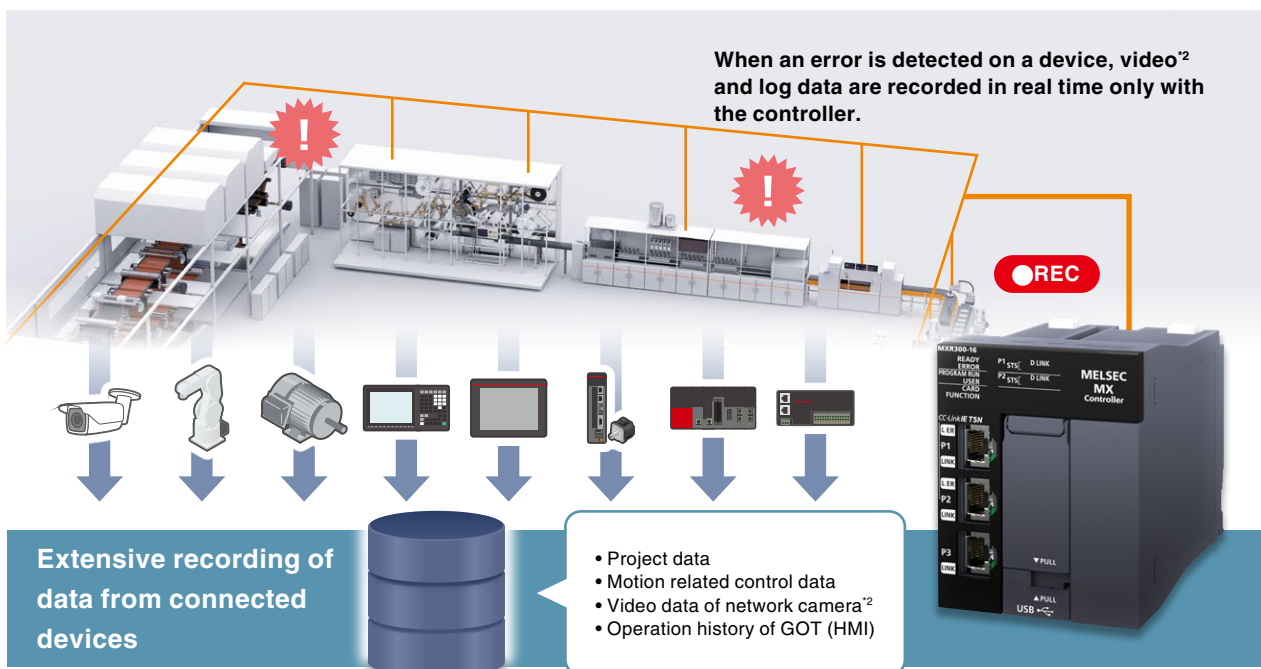

Data is automatically recorded before and after a problem occurs and at the start of the facility cycle

» Recording before and after a problem occurs

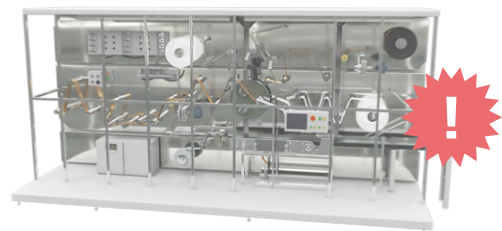
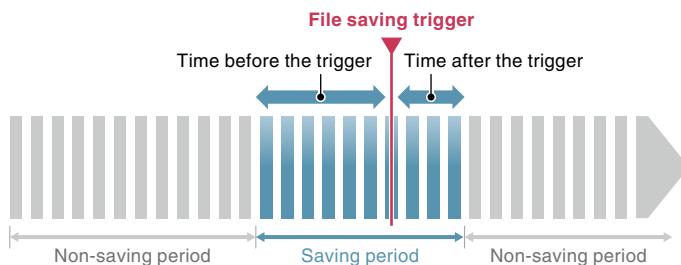

- Data is recorded for specified periods before and after a problem occurs, enabling efficient root cause analysis
- Data can be collected in sync with motion operation cycles
- Recorded data can be saved to a network drive

*1: Co-recording function will be supported in the future.
*2: A camera recorder module is required.

Easily review items that need attention by marking problem areas **NEW**

MX-R
Future support*
MX-F

The vast amount of recorded data is narrowed down to the items that need attention, reducing the time and effort required to identify the root cause.

GX VideoViewer Pro
GX VideoViewer
GX LogViewer
GX Works3

- Record points in the video
- Categorize and record points in the video
- Compare and analyze multiple videos and data

Color-coding of log marker by type

Frame-by-frame playback with different speeds

Comment display with mouseover

*1: Dedicated FBs are required to link cameras.

AI analysis instantly extracts differences in appearance and movement

Future support

MX-R

Future support*

MX-F

GX VideoViewer Pro uses AI to automatically detect anomalies in video and adds log markers at points of deviation from normal conditions. This streamlines the process of pinpointing the cause of problems.

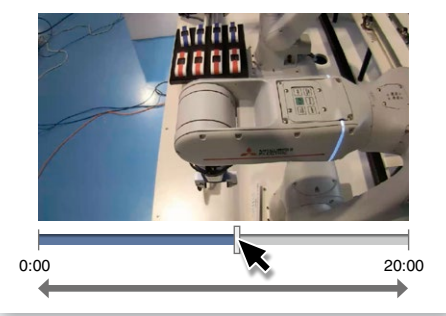

Visually check the difference

- Human visual inspection can miss anomalies.
- The time required depends on the skill of the worker.

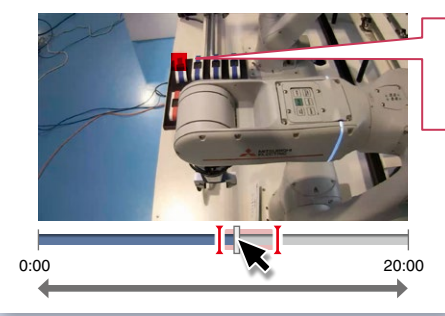

Marking a difference automatically

- Difference on the video
- || Difference on the seek bar

AI assists in extracting the difference

- Anomalies are extracted and marked on the video and seek bar, making review easy.
- Anomalies can be detected even in high-speed motion that the human eye cannot follow

*1: Dedicated FBs are required to link cameras.

Root cause analysis made easy with coordination between tools **NEW**

MX-R
Future support
MX-F

Even if the playback speed is changed, the timing between the video, program monitor, and device waveform data can be maintained, each showing the target moment.

You can analyze from multiple perspectives while checking points of change.

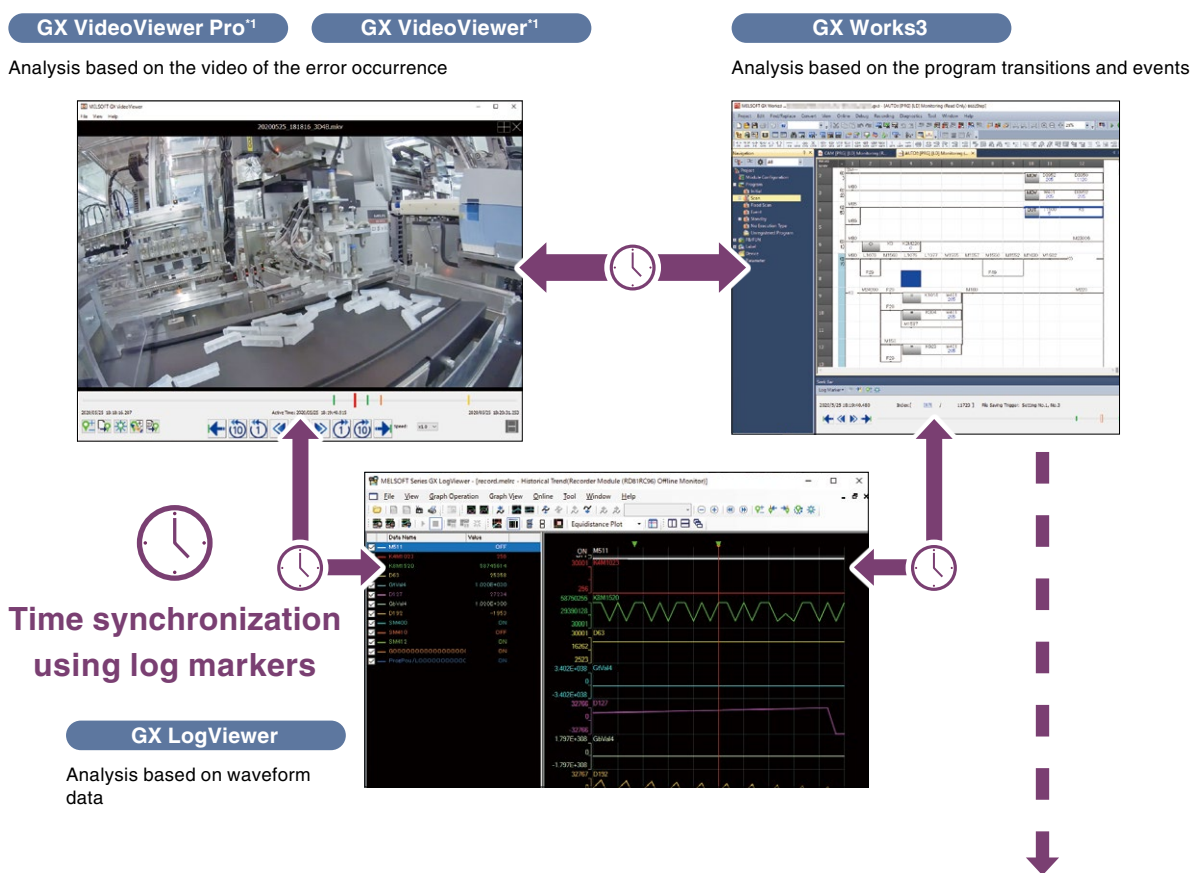

Check the range affected by a device/label at a glance

You can check the range affected by a device/label at a glance, making it easy to perform integrated analysis.

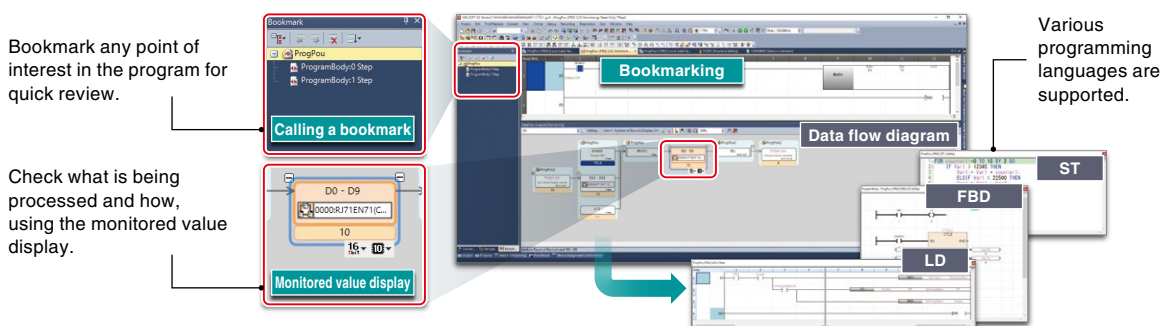

*1: Dedicated FBs are required to link cameras for MX-F model.

Speed up program debugging and analysis

MX-R
MX-F

Easily identify problematic code using GX Works3 diagnostic function. Use the system monitor to check the module configuration and the error status of the system. View the event history to see errors and operations performed in the controller and motion in chronological order, including detailed error information, causes, and corrective actions.

Quickly debug and analyze complex programs with many labels and structures.

System monitor

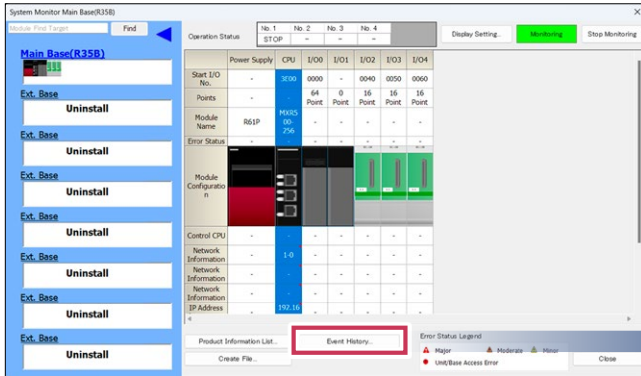

Event history

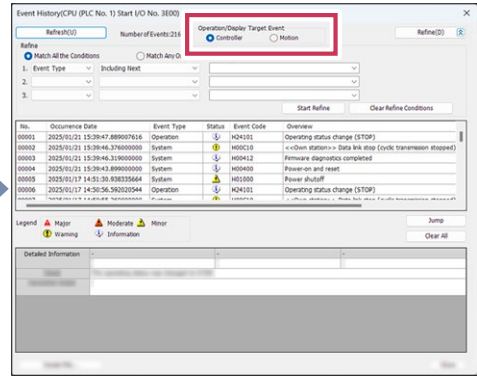

Analyze both sequence and motion programs simultaneously

One-stop search and analysis are available even for large programs with many labels and structures.

Select data of interest (device or label) to visually display related data that affects changes in the selected data in a flow diagram.

You can jump from the flow diagram to the corresponding part of the program, making it easy to identify the cause.

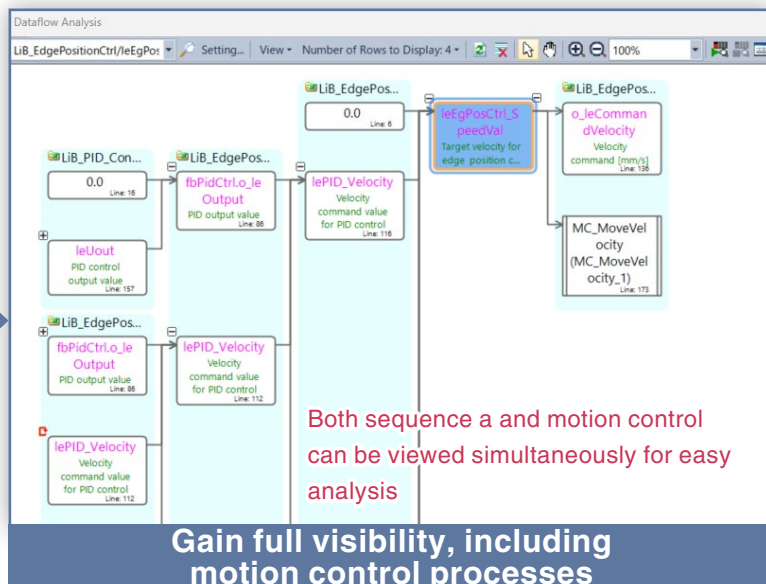
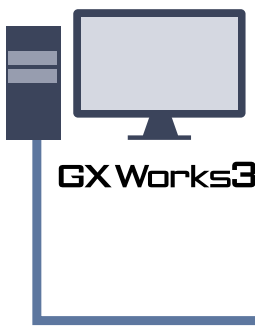

Gain full visibility, including motion control processes

Data flow analysis

AI-assisted root cause analysis NEW

MX-R
MX-F

Track device relationships that are not apparent in the program using AI. Efficiently debug issues where the program appears fine but the equipment stops without generating errors through AI-powered data flow analysis. For AI analysis, recording*1 and logging files from normal operation of the equipment or machine are required.

Machine suddenly stopped.

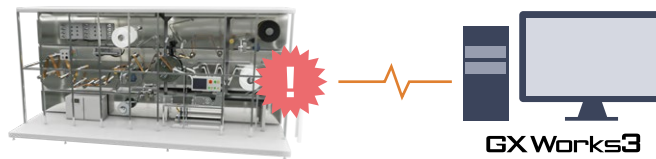

Before Analysis by conventional function

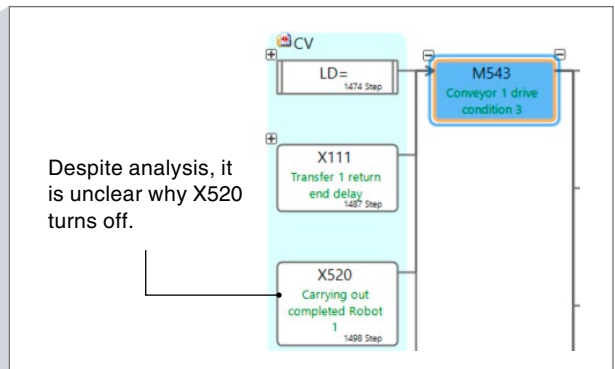
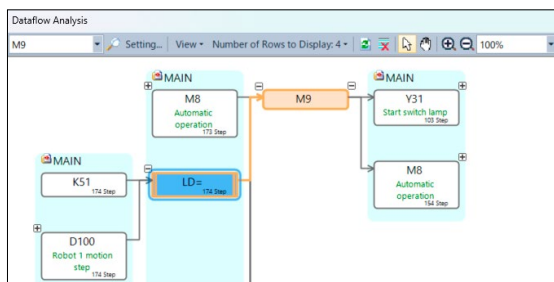

After Analysis by AI analysis function

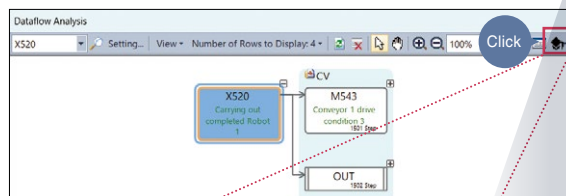

- AI Analysis...
- Import Analysis Result...
- Export Analysis Result...

Up to three of the most relevant results from the AI analysis are displayed. Let's check these to pinpoint the root cause.

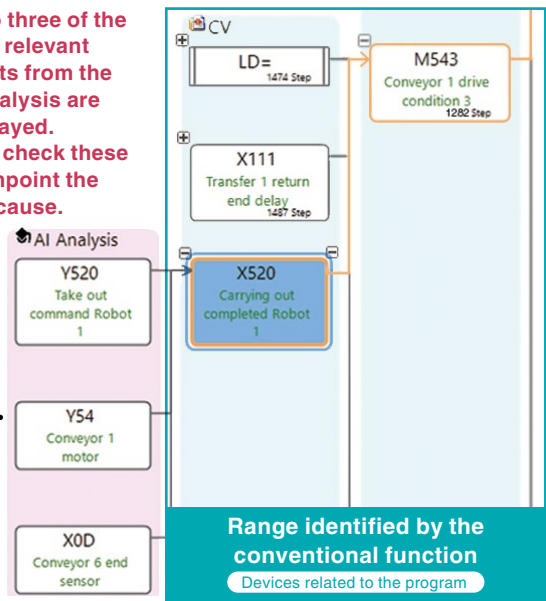

*1: Recording file for MX-F model will be supported in the future.

Automatically generate network parameters

MX-R
Future support
MX-F

Simply connect the engineering software to the manager station and click a button on the screen to automatically detect the system configuration and generate network parameters. Even if the system configuration is changed, you can easily update the parameters with the same simple operation. This significantly reduces network setup time.

1 Example of actual system configuration (first time)

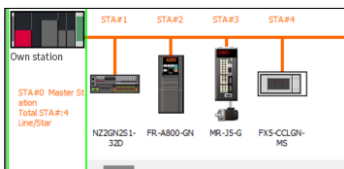

2 Example of changed system configuration

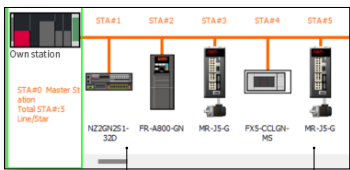

Remains as the reserved stations

Added as a new station

Engineering software

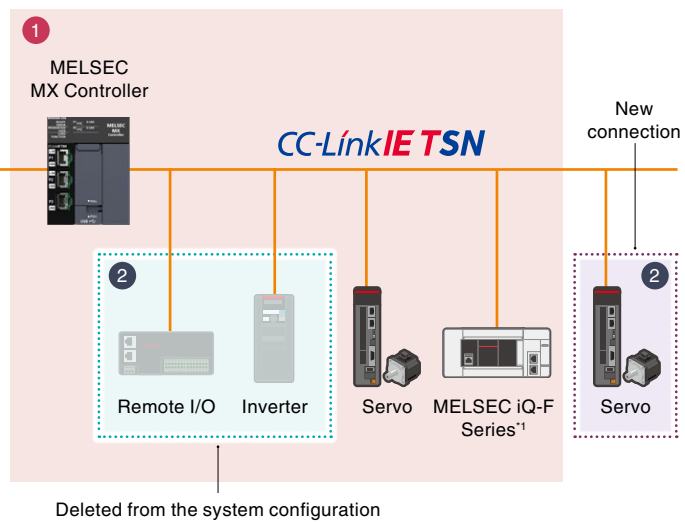

*1: Local stations will be supported in the future.

Reduce maintenance time with automatic parameter distribution

MX-R
MX-F^{*1}

When a device is powered on or reconnected, parameters stored in the manager station are automatically distributed to the device. Even after replacing a device, there is no need for individual parameter writing, ensuring a smooth and efficient replacement process.

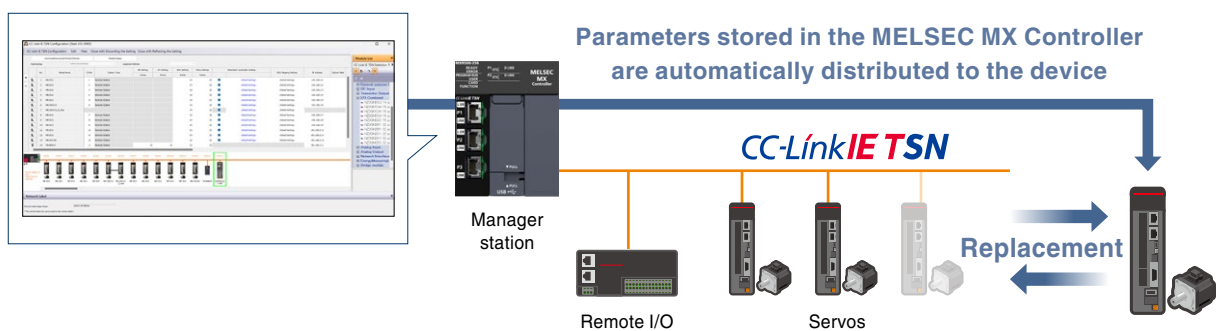

Easier troubleshooting reduces downtime

MX-R
MX-F^{*1}

The location of a cable disconnection and error can be quickly found by visualizing the CC-Link IE TSN network system image in order of connection using the engineering software GX Works3. Since diagnostics information can be checked in real time, a network error due to an unexpected wiring change and module setting change can be quickly found, reducing downtime.

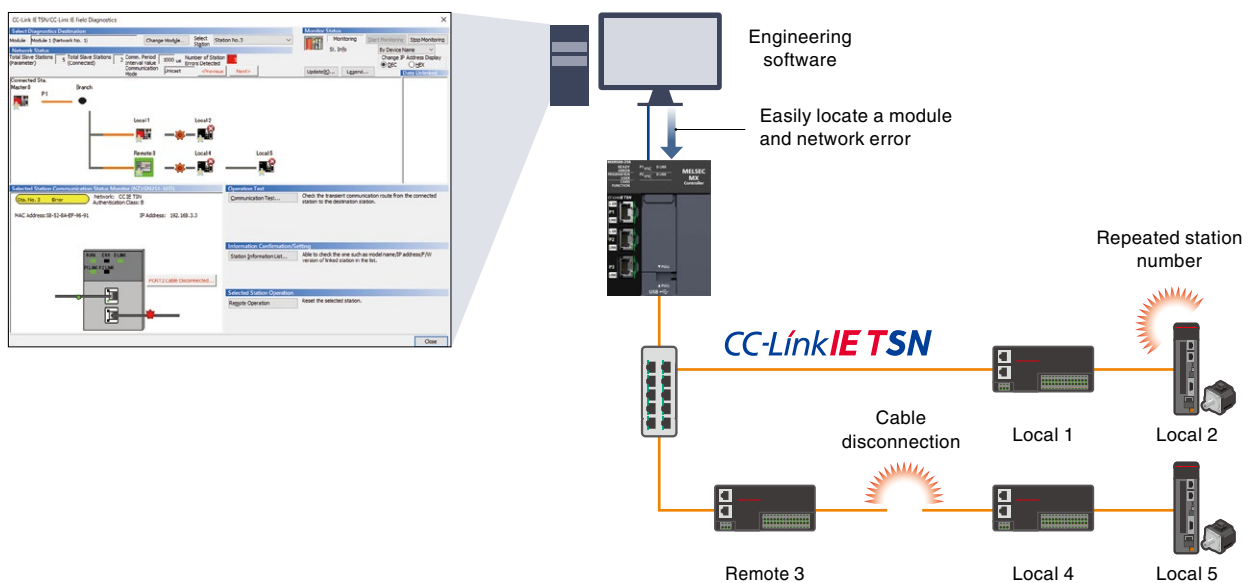

*1: MXF100-8-N32-EC and MXF100-16-N32-EC are not supported.

Digital transformation in factories

Security/information linkage



Achieve centralized management and sharing of valuable data

Boost work efficiency through data sharing and centralized management. Information can be shared from each device to the IT system.

Protect assets from cyberattacks

MX-R

MX-F¹

Prevent eavesdropping and unauthorized access with encrypted communication and user authentication for both OT and IT environments, safeguarding your assets and preventing machine malfunctions.

The MELSEC MX Controller complies with IEC 62443-4-2, the security standard for protecting control systems from cyberattacks.

The controller detects program tampering at startup, preventing the execution of unauthorized programs.

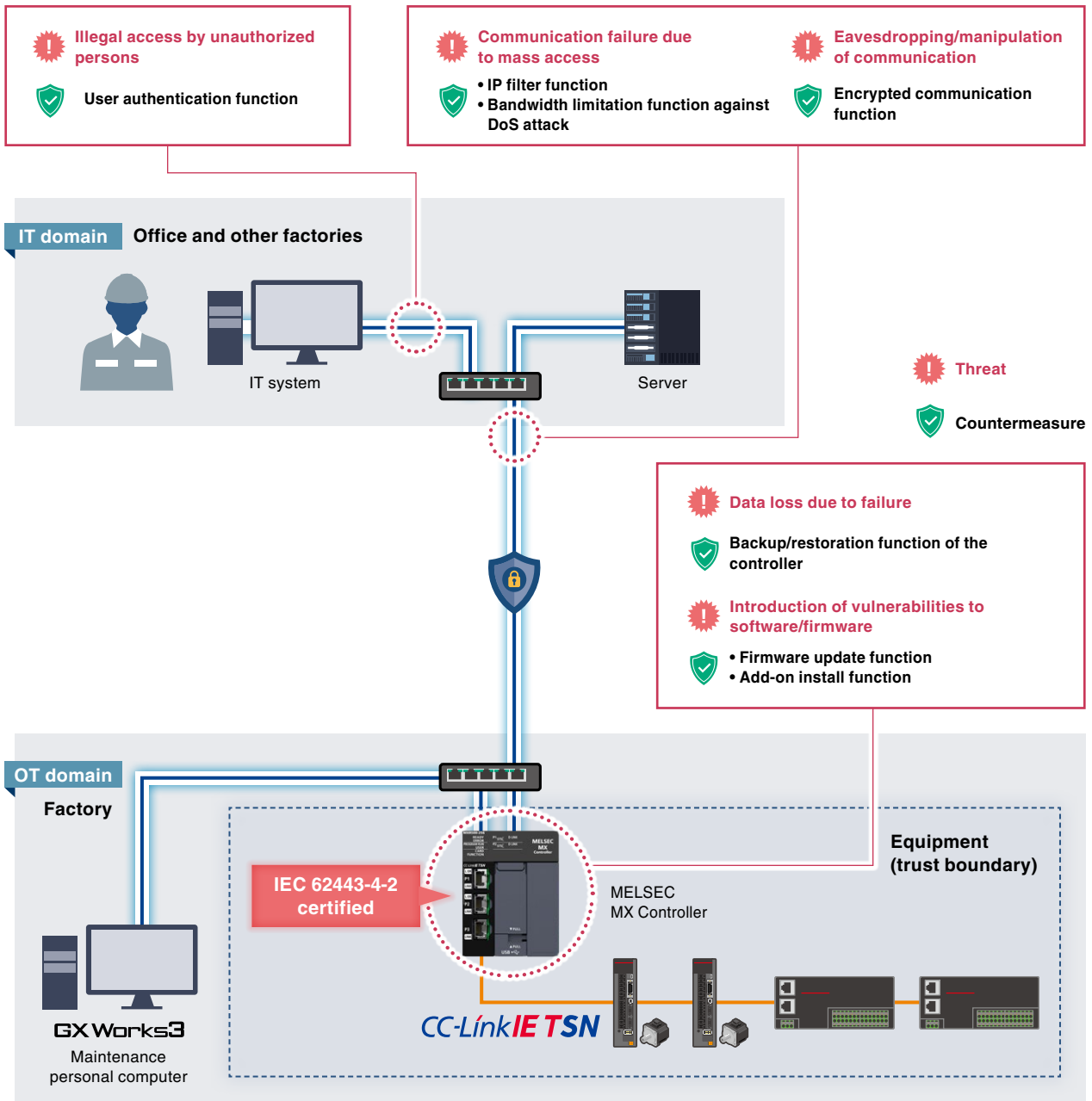

■ Security measures are required for the entire FA system.

¹: MXF100-8-N32-EC and MXF100-16-N32-EC will be supported in the future.

Secure and seamless connection to IT system

Future support*1
MX-R

Future support*1
MX-F

The OPC UA server and client functions are included as standard. A single MELSEC MX Controller can communicate with the IT system (server function) and with OPC UA-compatible programmable controllers in the production line (client function).

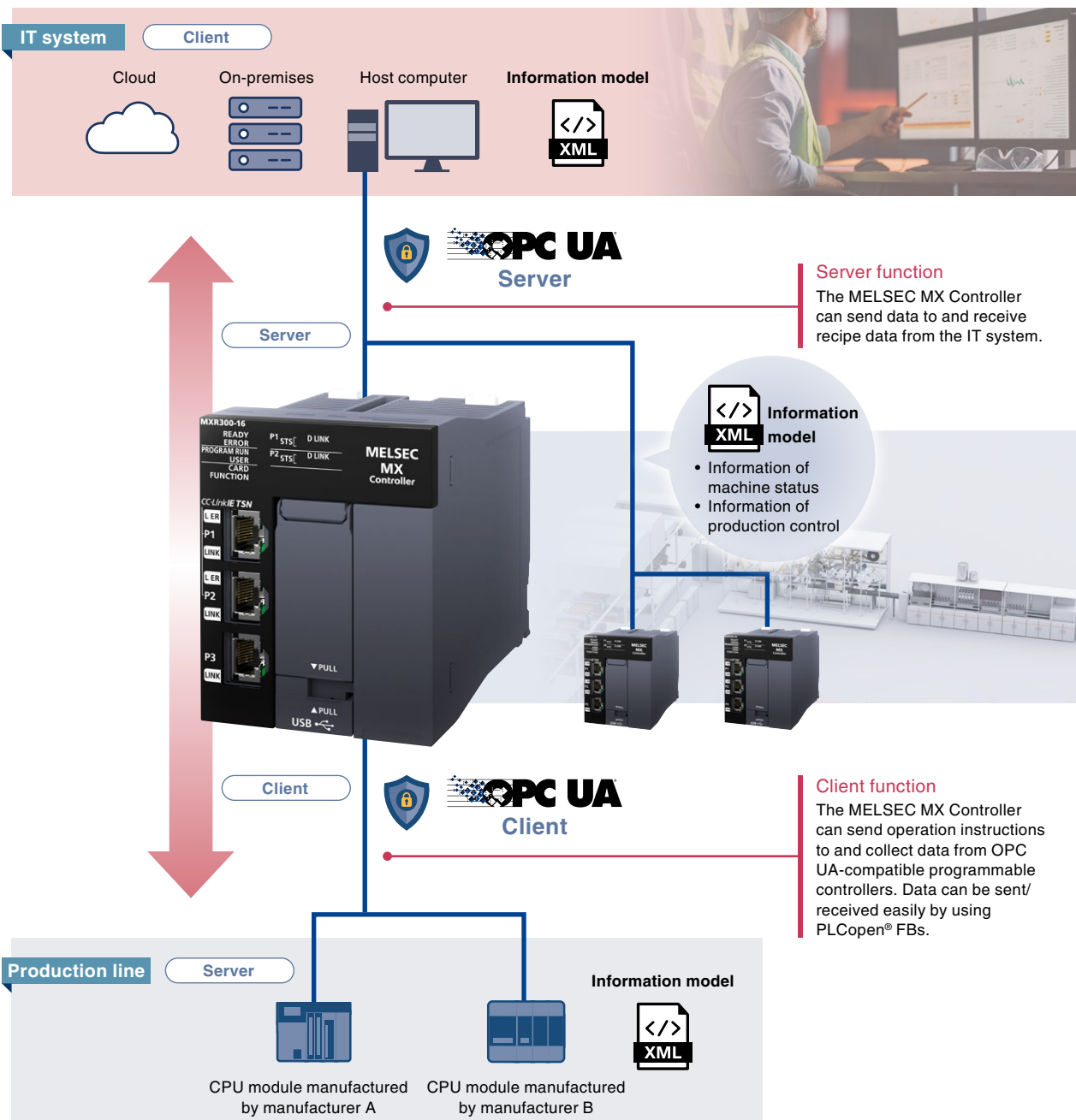

*1: The server function is supported. The client function and information models will be supported in the future.

Smart, centralized data management with network drive connectivity **NEW**

MX-R
Future support
MX-F

Centrally manage data on a network drive and easily access it from anywhere as if it were your drive. After connecting to the network drive, you can store data just like the built-in memory or an SD card, allowing you to store large amounts of data for long periods of time.

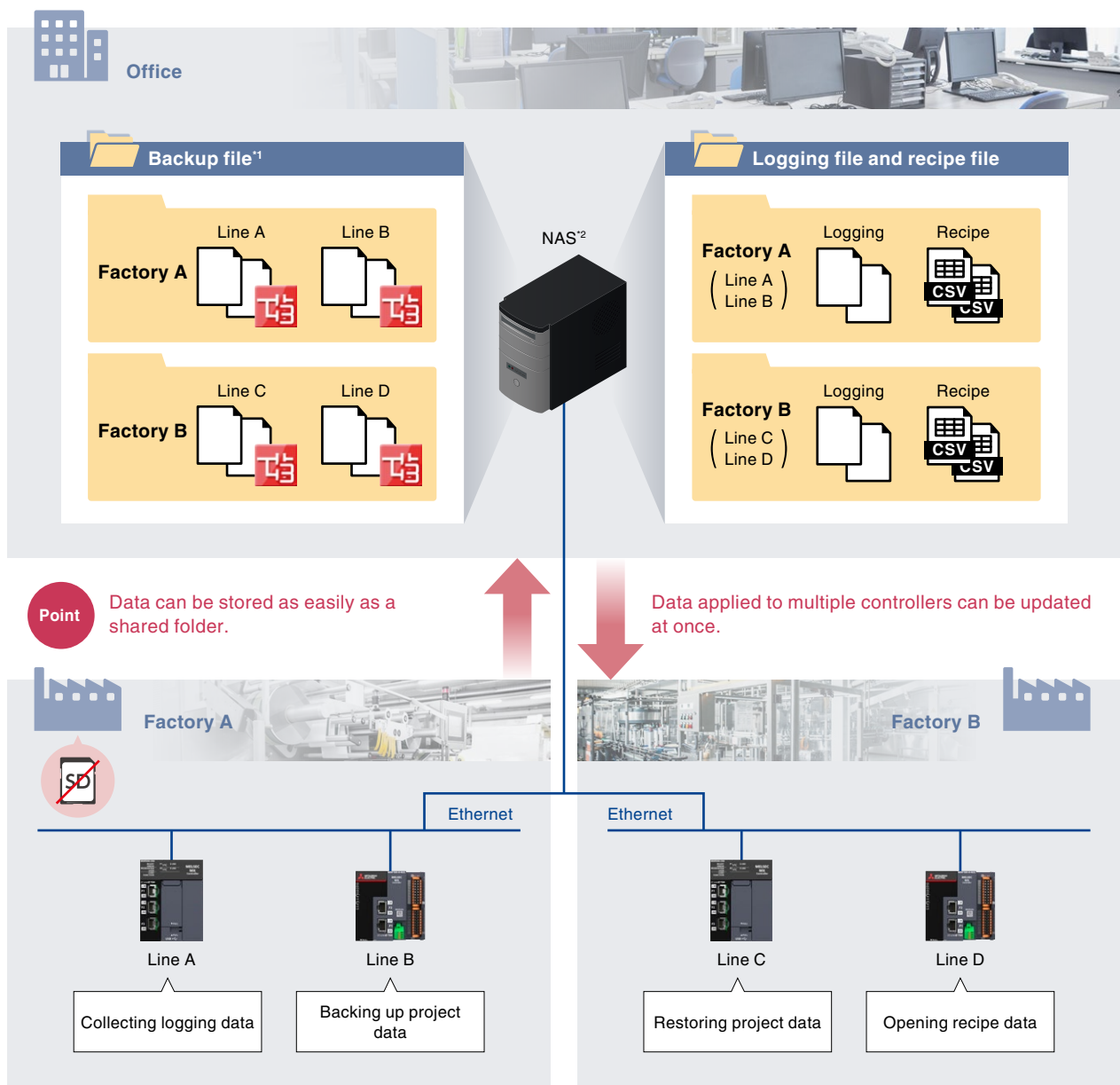

*1: Backup and restoration functions will be supported in the future.
*2: Network Attached Storage

Monitor remote equipment status from anywhere

MX-R
Future support
MX-F

Use any browser-enabled device to monitor without restrictions on people or location.

The web server function allows you to monitor equipment status from various devices such as personal computers, tablets, and smartphones.

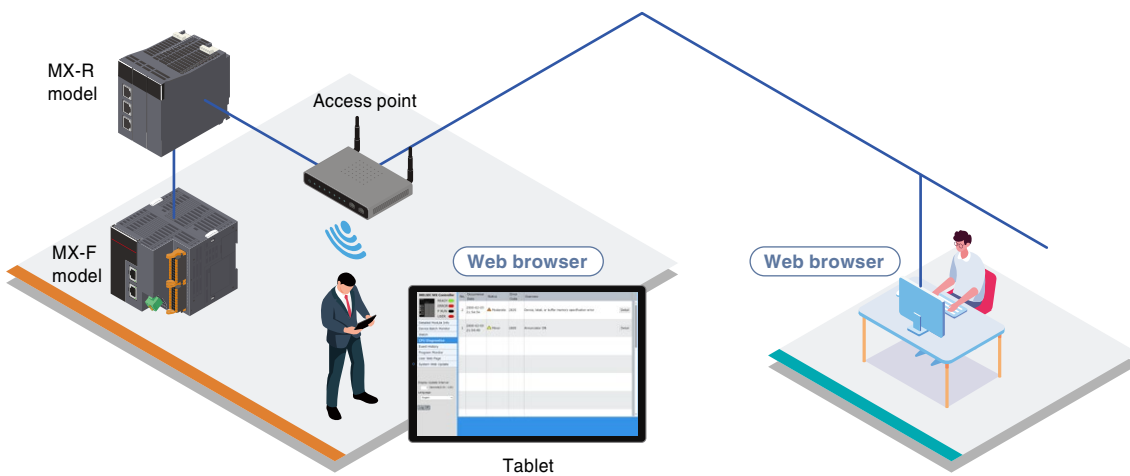

Factory Can be monitored without GX Works3

Office Can be monitored remotely

Quickly check the status of equipment around the time a problem occurs

View error details, program operating status, and device status in your browser for a quick initial assessment when a problem occurs.

Streamline maintenance by performing preliminary diagnostics prior to field investigation.

CPU diagnostics					
MELSEC MX Controller	No.	Occurrence Date	Status	Error Code	Overview
READY ● ERROR ● P RUN ● USER ●	2	2025-08-21 14:54:48	Moderate ▲	2820	Device, label, or t
Detailed Module Info Device Batch Monitor Watch	1	2025-08-21 14:54:45	Minor ▲	1800	Annunciator ON
CPU Diagnostics Event History Program Monitor User Web Page System Web Update					

The error history and the cause of each error can be checked.

Program monitor	
MELSEC MX Controller READY ● ERROR ● P RUN ● USER ●	Scan 1:MAIN 2:ProgPou1 0 Display in HEX Verif
Detailed Module Info Device Batch Monitor Watch CPU Diagnostics Event History Program Monitor User Web Page System Web Update	
Display Update Interval 1 Seconds(0.1-120)	Language English
Log Off	

The on/off status of contact and coil, the current value of device/label, and the input/output status of FB/FUN can be checked.

Easily create custom screens with the information you need

MX-R
Future support
MX-F

Design your original web pages

You can create original web pages for monitoring equipment status using numeric values, graphs, and images.

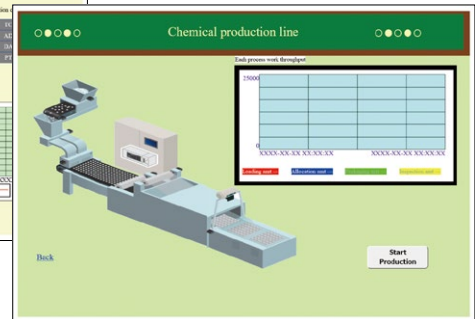
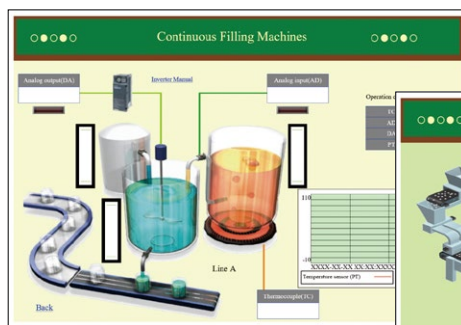

Point View equipment status at a glance with your custom screen.

Simply drag and drop components

With our User Web Page Design Tool, you can create custom screens without any programming knowledge. Just place components and configure devices to build your screens.

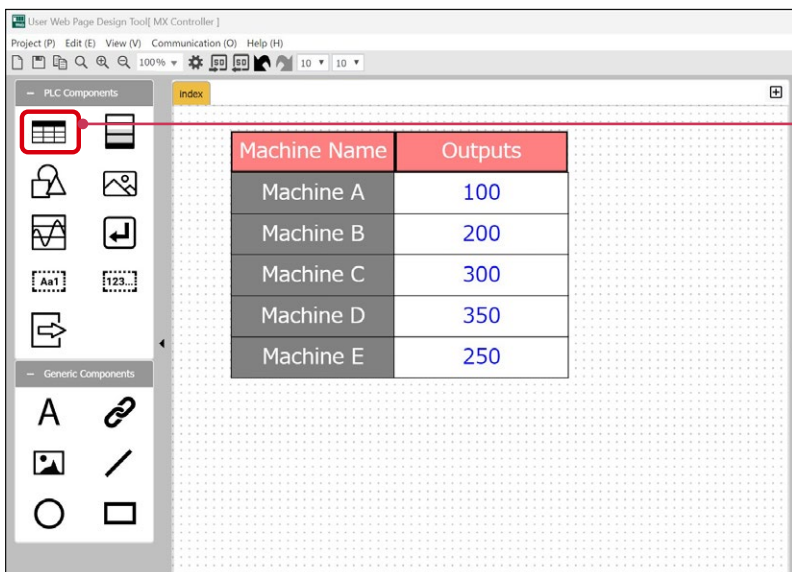

Drag and drop components from the list.

Free of charge
Design tool

Mitsubishi Electric's Digital Twin

REAL

Mitsubishi Electric has enhanced hardware/software coordination. Advanced simulations replicate real manufacturing processes in a virtual space through digital twins. Leveraging years of expertise, our software development will continue to evolve.

Low-speed
(second order)
Large scale

Production Line

VIRTUAL

STEP 1 Layout concept

» 3D simulator

MELSOFT Gemini

Achieves more productive facility design and virtual commissioning.

» Logic simulator

MELSOFT Mirror

Desktop review of the control logic, including inter-process coordination and machine response

» Development environment of model-based design

MATLAB® Simulink®

Control algorithm, physical model verification

STEP 2 Machine review

STEP 3 Mechanism design



STEP 6 Line assembly and operation

» SCADA software

GENESIS™

Visualizes everything on the factory floor.



STEP 5 Machine verification



STEP 4 Mechanism adjustment

Machines

Mechanism

High-speed
(ms order)
Small scale

» Engineering software

MELSOFT GX Works3

Integrated engineering environment

MELSOFT GX VideoViewer Pro

Automatically extracts differences from videos and analyzes an error cause by AI analysis.

MELSOFT GX LogViewer

Waveform data check and simple analysis

Leverage the fusion of digital and hardware with our digital twin environment

Future support

MX-R

Future support

MX-F

Simulation technologies such as MELSOFT Gemini and MELSOFT Mirror are integrated with Mitsubishi Electric's hardware, field and control expertise, and open innovation, allowing you to front-load your facility design, build highly productive production systems and achieve accurate digital twin.



3D simulator

MELSOFT Gemini

Mechanical behavior display

Sensor response



3D simulator that drives the digital transformation of facility design work

The operation of production line and facility is visualized in 3D space. As a comprehensive facility design platform that can be used in every phase, from conceptual through detailed design phases, it serves as a hub for communication and data sharing across departments. It helps you build highly productive systems while significantly reducing costs.

Benefits of MELSOFT Gemini

One tool for all design phases

From conceptual to detailed design, MELSOFT Gemini enables cost-effective design operations at every stage.

Communication and data hub

MELSOFT Gemini facilitates accurate communication and information transfer between conceptual, mechanical, and control design phases, promoting front-loading and reducing rework.

Leverage simulation data for real-world improvements

Reduce hardware engineering time by input/output of control programs based on MELSOFT Gemini simulation data.

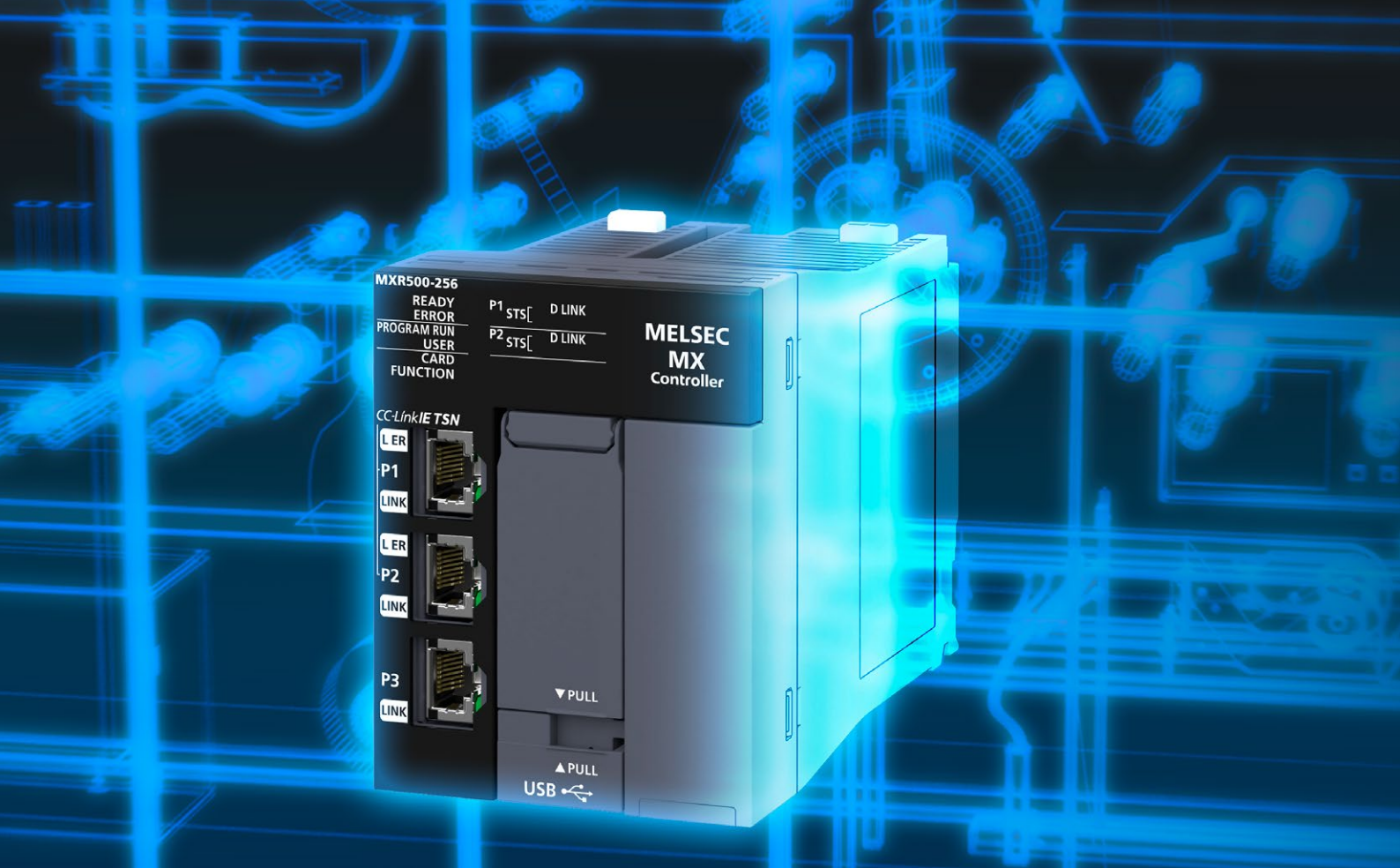

Logic simulator

MELSOFT Mirror

Control logic operation

Machine response operation



Run control programs in a virtual environment

Verify equipment behavior using actual control programs without the need for physical hardware.

Test the interactions of multiple processes and programs for largescale systems, accelerating equipment development.

Benefits of MELSOFT Mirror

You can verify behavior without physical hardware

Test new equipment virtually before actual implementation.

You can verify complex control processes

Verify processes and interlocks across multiple processes and stations by combining different control programs.

You can verify anytime, anywhere, with multiple people

Perform verification from remote locations using the same virtual equipment. Share equipment operation in real time to make verification more efficient.

Advance front-loading with MATLAB®/ Simulink® for model-based development (MBD) and automatic code generation

MX-R

MX-F

FBs (structured text language) are automatically generated from control models, such as tension control and PID, verified by MATLAB®/Simulink®. This reduces coding time and effort and minimizes errors. The behavior of the generated FBs can be verified using the GX Works3 simulator, MELSOFT Mirror^{*1}, or physical hardware. Based on verification results, you can identify and correct errors at an early stage.

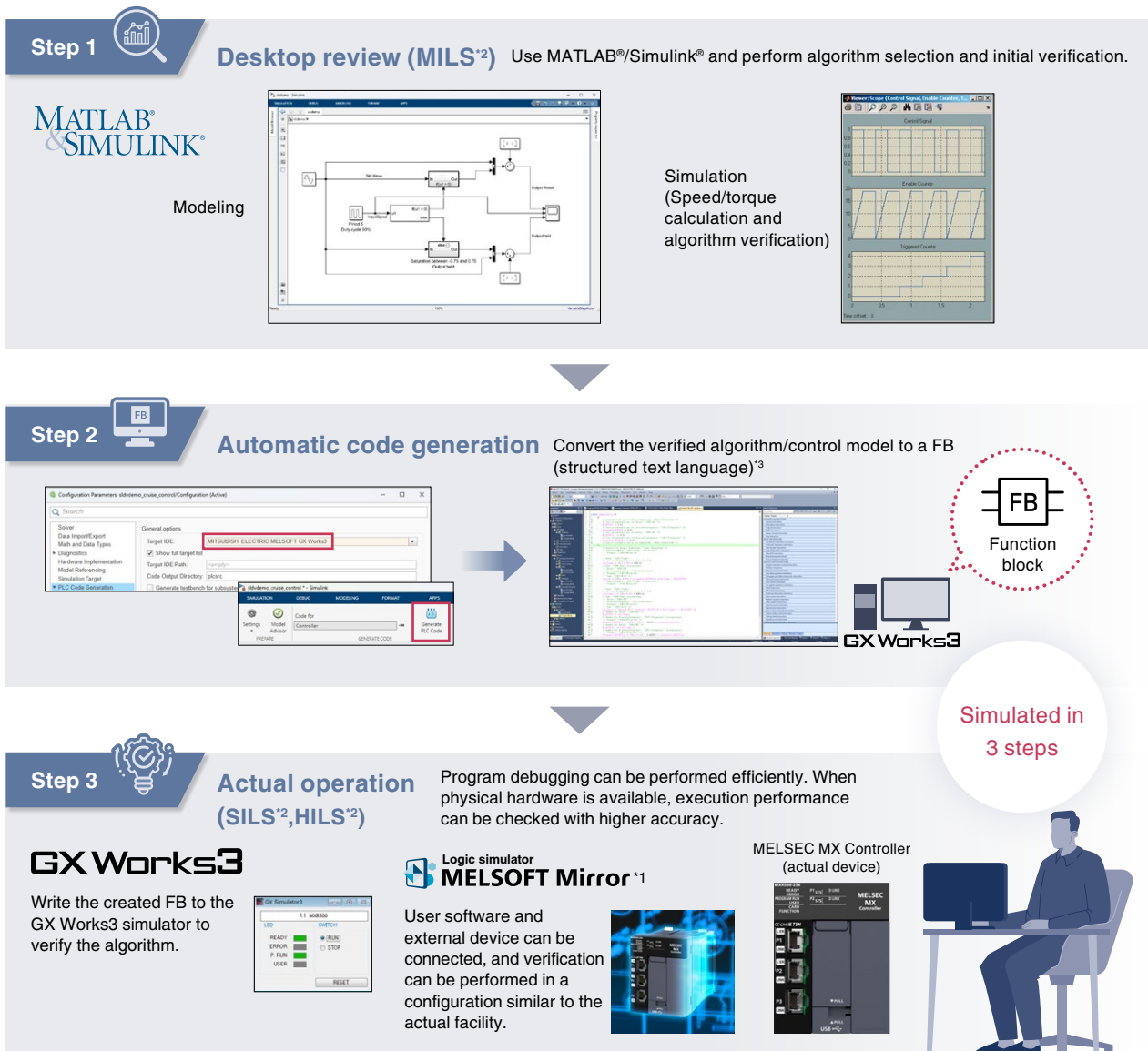

*1: Future support
 *2: MILs: Model-in-the-Loop Simulation (Method for executing a system in a simulation environment using a modeled system)
 SILs: Software-in-the-Loop Simulation (Method for executing software in a simulation environment without using actual hardware)
 HILs: Hardware-in-the-Loop Simulation (Method for executing a system in a simulation environment using actual hardware)
 *3: Convert to a function block using Simulink® PLC Coder™.

Products

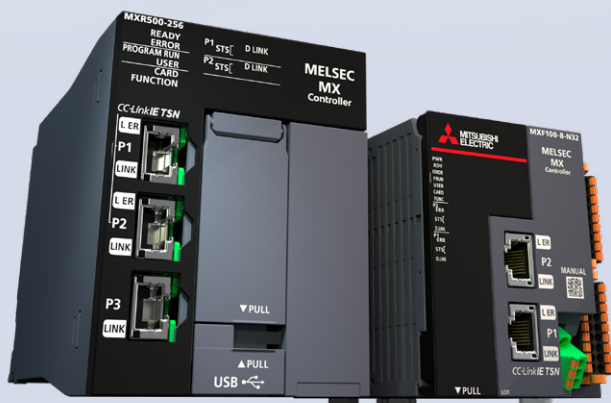

- Basic system configuration (MX-R model)
- Basic system configuration (MX-F model)
- List of CC-Link IE TSN connection devices
- Servo system compatible with MELSEC MX Controller

Basic system configuration (MX-R model)

The MELSEC MX Controller (MX-R model) is mounted on the MELSEC iQ-R Series main base unit. This product can be used in combination with the products listed in the "List of devices that support MELSEC MX Controller (MX-R model)" below.

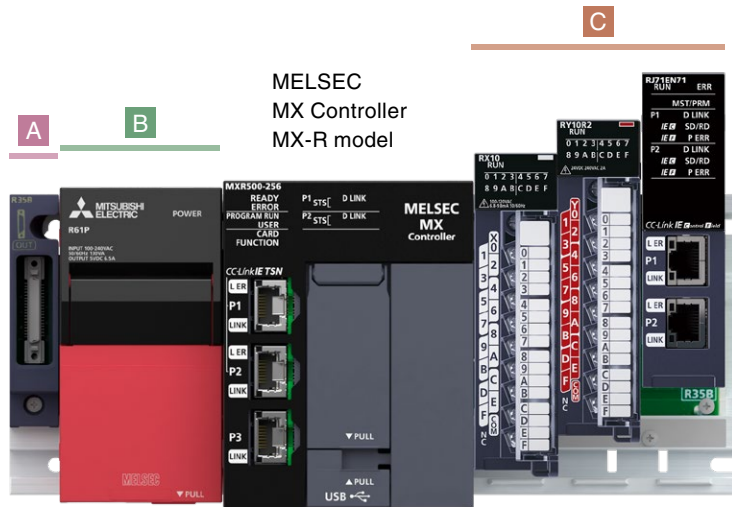

For details on the MELSEC iQ-R Series, refer to the "MELSEC iQ-R Series iQ Platform-compatible PAC" (L(NA)08298ENG).

List of devices that support MELSEC MX Controller (MX-R model)

A Base unit

Main base	R33B, R35B, R38B, R312B	
Extension base	Extension base	R65B, R68B, R612B
	Extended temperature range extension base	R610B-HT
Extension cable	RC06B, RC12B, RC30B, RC50B, RC100B	

B Power supply module

Power supply	R61P, R62P ¹⁾ , R63P, R64P, R69P
Redundant power supply	R63RP, R64RP, R69RP

C Modules that support MELSEC MX Controller (MX-R model)

I/O module		High-speed counter module, isolated pulse input module, flexible high-speed I/O control module		
AC input	RX10	High-speed counter	RD62P2, RD62D2, RD62P2E	
	RX10-TS	Channel isolated pulse input	RD60P8-G	
	RX28	Flexible high-speed I/O control	RD40PD01	
DC input	RX40C7, RX41C4, RX42C4	Positioning module	Positioning	RD75P2, RD75P4, RD75D2, RD75D4
	RX40C7-TS, RX41C4-TS, RX70C4, RX71C4, RX72C4			
	RX40PC6H, RX40NC6H			
DC high-speed input	RX41C6HS, RX61C6HS	Information module	Ethernet interface with built-in CC-Link IE	RJ71EN71
	RX40NC6B			Serial communication
Input with diagnostic functions	RY10R2	MES interface	RD81MES96N	
	RY10R2-TS		GP-IB interface	RJ71GB91
Contact output	RY18R2A	Camera recorder		RD81RC96-CA
	RY20S6		Network module	CC-Link IE TSN
Triac output	RY40NT5P, RY41NT2P, RY42NT2P, RY40PT5P, RY41PT1P, RY42PT1P	CC-Link IE Controller Network		
	Transistor output		RY40NT5P-TS, RY41NT2P-TS, RY40PT5P-TS, RY41PT1P-TS	RJ71GN11-EIP
Transistor high-speed output		RY41NT2H, RY41PT2H	RJ71GP21-SX	
	Output with diagnostic functions	RY40PT5B	RJ71GP21S-SX	
I/O combined		RH42C4NT2P	CC-Link IE Field Network	RJ71GF11-T2
	Analog module	Analog-digital conversion	CC-Link system master/local	RJ61BT11
R60AD4, R60ADI8, R60ADV8			AnyWireASLINK master	RJ51AW12AL
High-speed analog-digital conversion	R60ADH4	CANopen [®]	RJ71CN91	
	Channel isolated analog-digital conversion	R60AD8-G, R60AD16-G	DeviceNet master/slave	RJ71DN91
Channel isolated analog input module	R60AD6-DG	BACnet [®]	RJ71BAC96	
	Digital-analog conversion	R60DA4, R60DAI8, R60DAV8	Energy measuring module	Energy measuring
High-speed digital-analog conversion	R60DAH4	Blank cover module		
Channel isolated digital-analog conversion	R60DA8-G, R60DA16-G		Temperature input module, temperature control module	Channel isolated thermocouple input
	Temperature input module, temperature control module	Channel isolated RTD input		
Temperature control			R60TCRT2TT2, R60TCRT2TT2BW, R60TCRT4, R60TCRT4BW	SD memory card
	R60TCRT2TT2-TS, R60TCRT4-TS	Battery	Battery	

*1: MXR500-□: Can be used only on the extension base unit.
MXR300-□: Can be used on the R33B, R35B, and extension base unit.

System configuration example

■ MELSEC MX Controller (MX-R model)

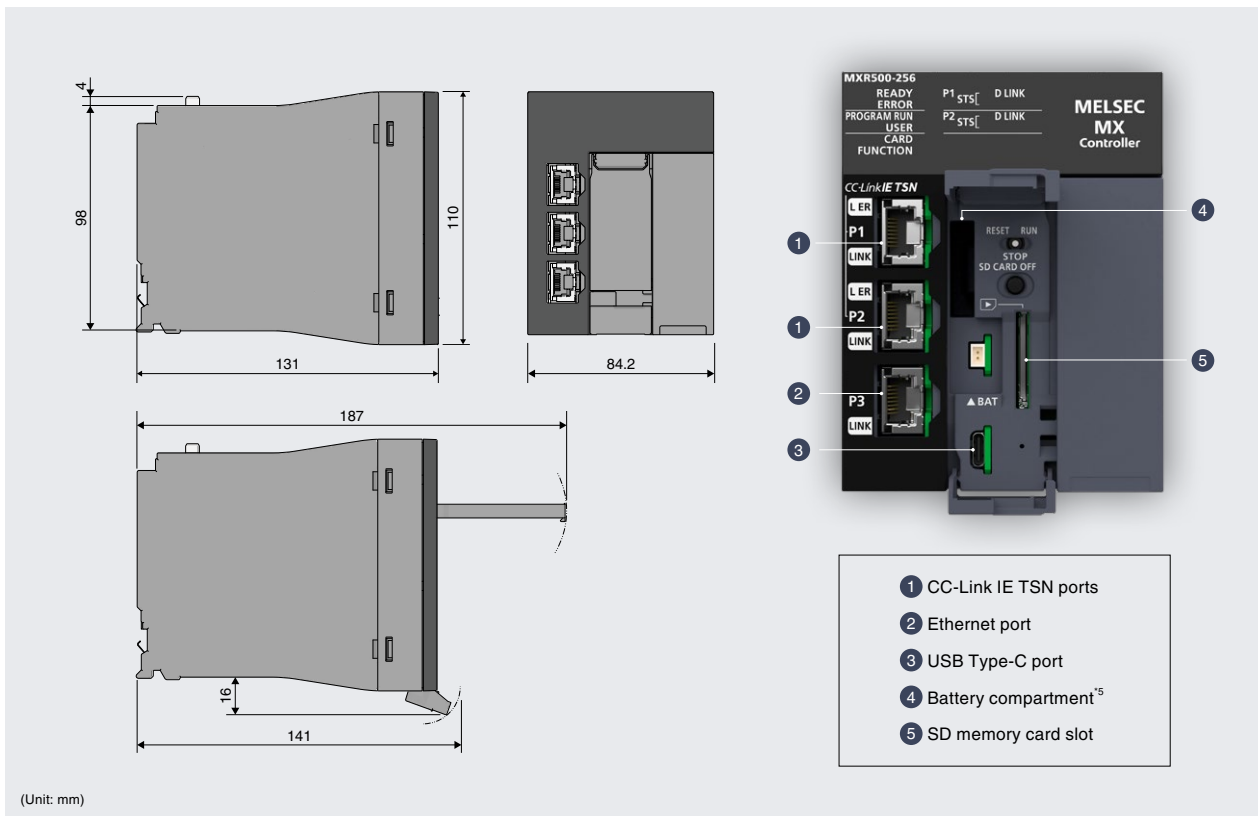
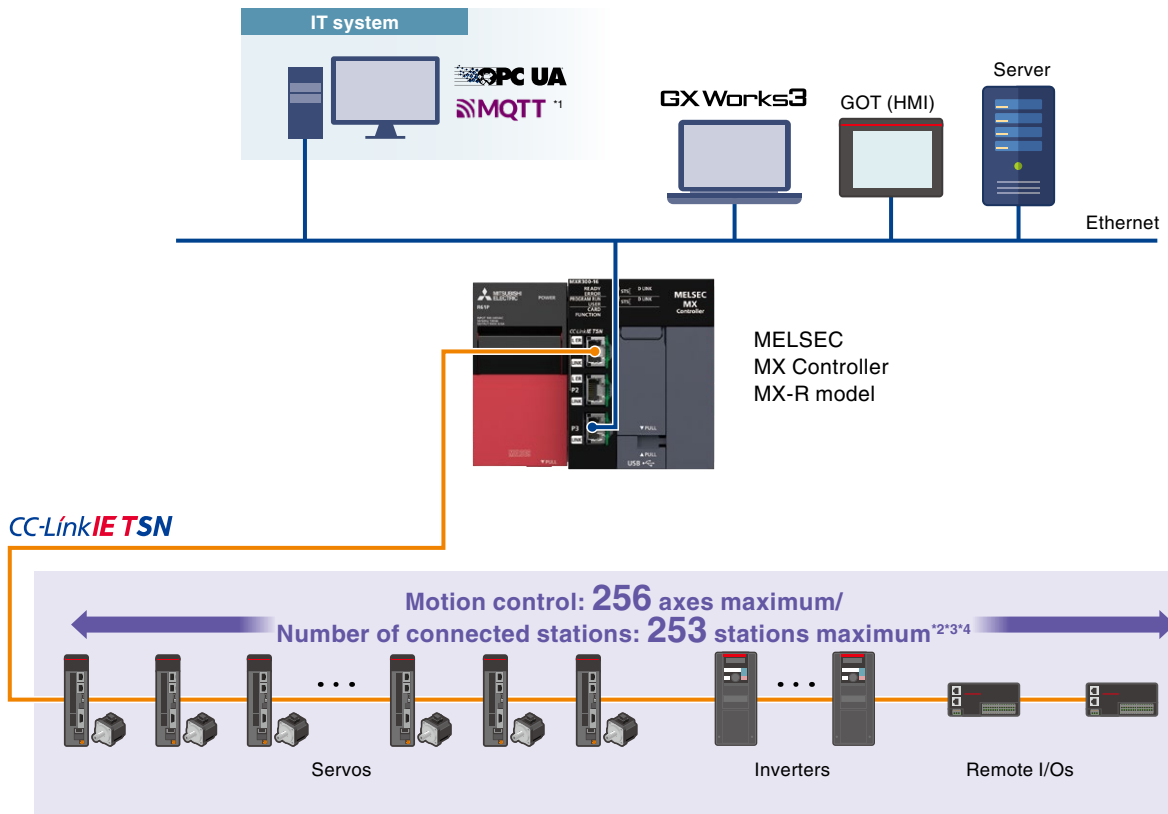

*1: Future support

*2: The multi-axis servo amplifier can control multiple axes with one station occupied. (The number of virtual axes is not included in the number of controllable axes.)

*3: Device stations supporting connections to 253 stations will be available in the future. For details, refer to the Technical Bulletin (FA-A-0451).

*4: Only the servo can execute motion control.

*5: Clock data can be retained during a power failure for 11 days or more. (Latch device/latch label contents can be retained during a power failure without the battery.)

Basic system configuration (MX-F model)

The MELSEC MX Controller (MX-F model) can be used with an extension connector type I/O module, MELSEC IQ-F Series expansion adapter and extension module, and intelligent function module.

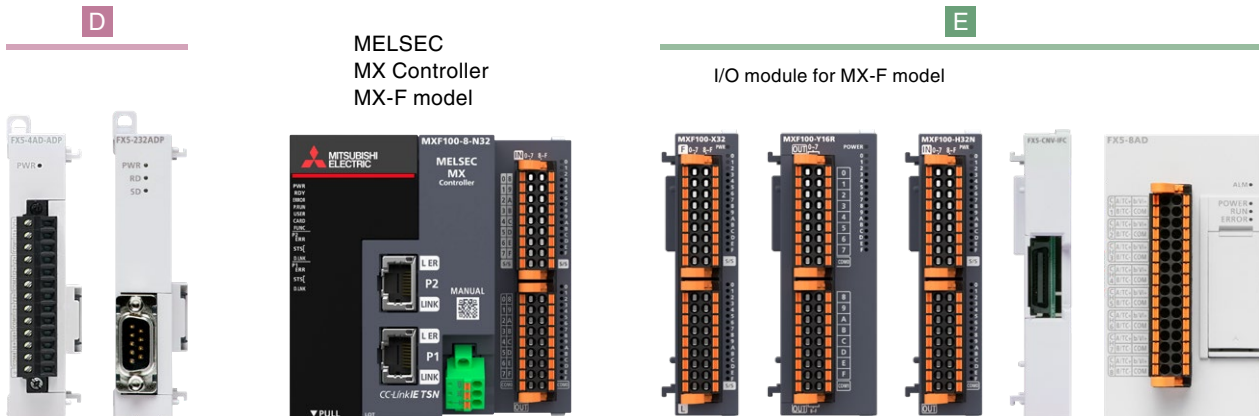

List of devices that support MELSEC MX Controller (MX-F model)

D Expansion adapter

Analog

Analog input	FX5-4AD-ADP
RTD temperature sensor input	FX5-4AD-PT-ADP
Thermocouple temperature sensor input	FX5-4AD-TC-ADP
Analog output	FX5-4DA-ADP
Analog I/O	FX5-4A-ADP

Communication

RS-232 communication	FX5-232ADP
RS-485 communication	FX5-485ADP

E Extension module

I/O module for MX-F model¹

Input	MXF100-X32
Output	MXF100-Y16R
	MXF100-Y32N
Input/output	MXF100-Y32P
	MXF100-H32N
	MXF100-H32P

I/O module²

Input	FX5-8EX/ES
	FX5-16EX/ES
Output	FX5-8EYR/ES
	FX5-16EYR/ES
	FX5-8EYT/ES
	FX5-16EYT/ES
	FX5-8EYT/ESS
	FX5-16EYT/ESS
Input/output	FX5-16ER/ES
	FX5-16ET/ES
	FX5-16ET/ESS
Powered I/O	FX5-32ER/DS
	FX5-32ET/DS
	FX5-32ET/DSS
High-speed pulse input/output	FX5-16ET/ES-H
	FX5-16ET/ESS-H

Intelligent function module

- High-speed counter²

High-speed counter	FX5-2HC/ES
--------------------	------------
- Analog²

Multiple input	FX5-8AD
Analog input	FX5-4AD
Analog output	FX5-4DA
Temperature control	FX5-4LC
- Information/Network²

CC-Link IE TSN master/local	FX5-CCLGN-MS
CC-Link system master/intelligent device	FX5-CCL-MS
Ethernet	FX5-ENET, FX5-ENET/IP
EtherNet/IP™	FX5-EIP
- Conversion module and others

Extension power supply unit	FX5-C1PS-5V
Connector conversion module	FX5-CNV-IFC
Extension cable ³	FX5-30EC
	FX5-65EC
Conversion adapter	FX5-CNV-BC

SD memory card

SD memory card	NZ1MEM-2GBSD, NZ1MEM-4GBSD, NZ1MEM-8GBSD, NZ1MEM-16GBSD
----------------	---

Battery

Battery	FX3U-32BL
---------	-----------



For details on the MELSEC IQ-F Series, refer to the "MELSEC IQ-F Series iQ Platform-compatible PLC" (L(NA)08428ENG).

¹: Some MELSEC IQ-F Series I/O modules can also be added. For details, refer to the "MELSEC MX Controller (MX-F Model) User's Manual" (SH(NA)-082634ENG).

²: When the extension cable type module is used, the FX5-CNV-IFC or FX5-C1PS-5V is required.

³: This module is available after connector conversion with the FX5-CNV-IFC or FX5-C1PS-5V.

System configuration example

■ MELSEC MX Controller (MX-F model)

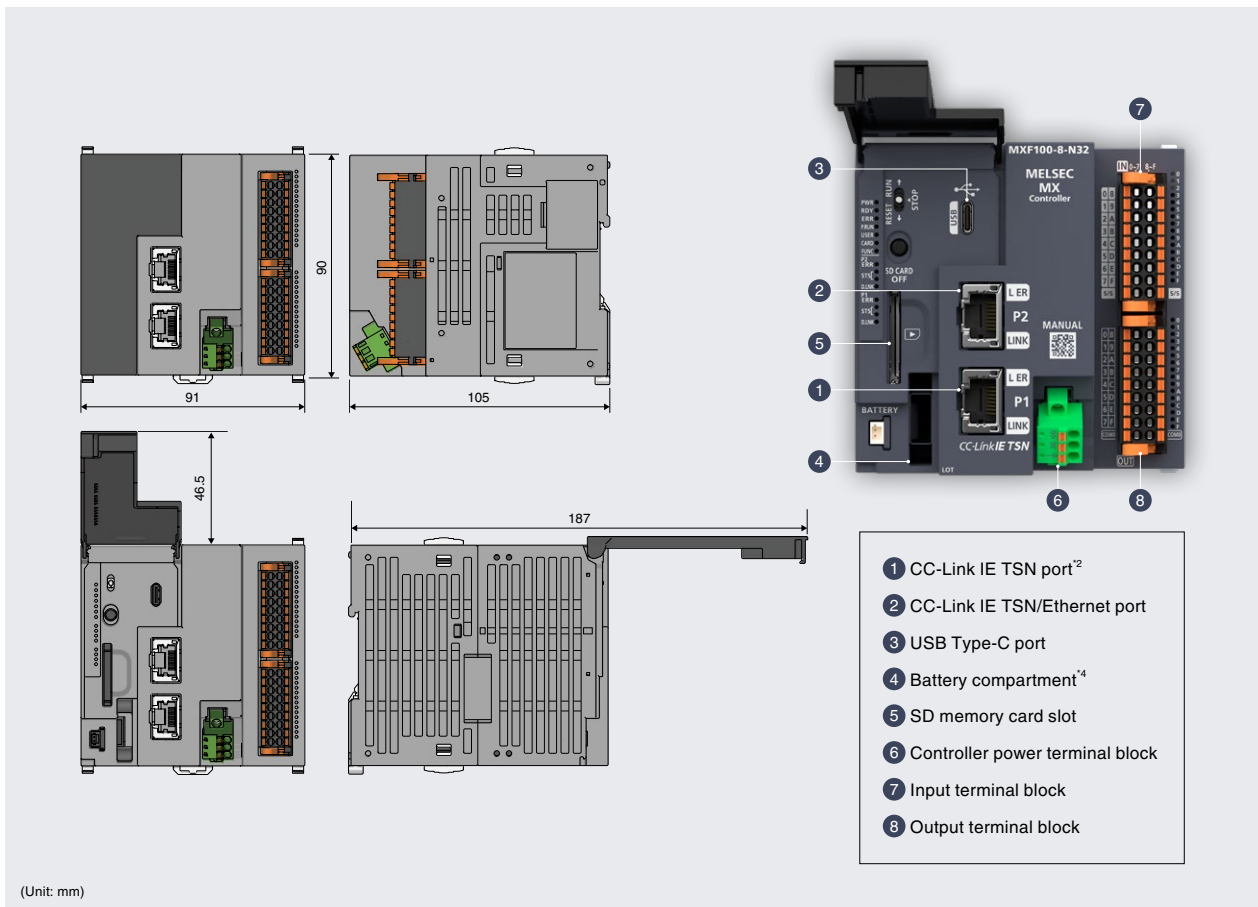
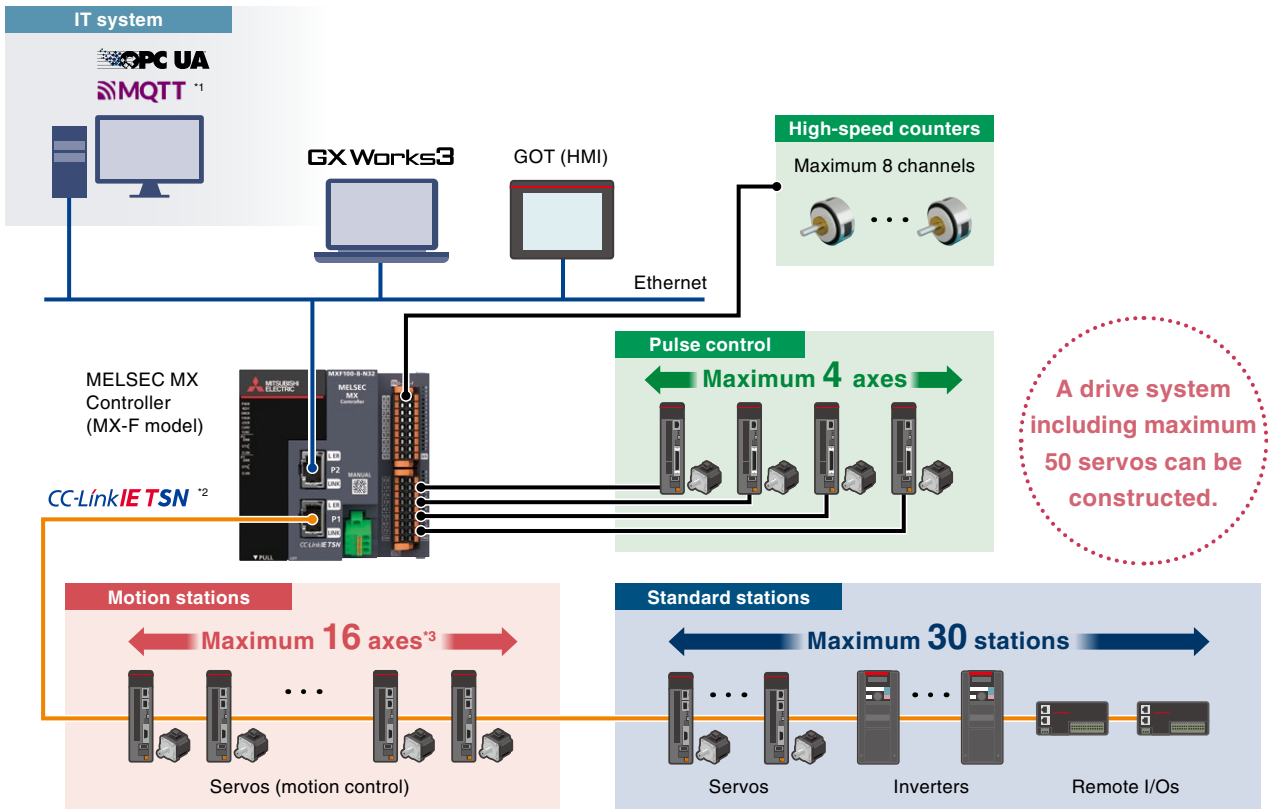

*1: Future support

*2: MXF100-8-N32-EC and MXF100-16-N32-EC have an EtherCAT port instead, and the system configuration constraints differ, such as the maximum number of stations.

*3: The number of virtual axes is not included in the number of controllable axes.

*4: Clock data can be retained during a power failure for 11 days or more. (Latch device/latch label contents can be retained during a power failure without the battery.)

■ Block type remote module

Input module

[Spring-clamp terminal block]

NZ2GN2S1-16D



NZ2GN2S1-32D



[Screw terminal block]

NZ2GN2B1-16D



NZ2GN2B1-32D



[Sensor connector (e-CON)]

NZ2GNCE3-32D



[40-pin connector]

NZ2GNCF1-32D



Output module

[Spring-clamp terminal block]

NZ2GN2S1-16T



NZ2GN2S1-16TE



[Screw terminal block]

NZ2GN2B1-16T



NZ2GN2B1-16TE



NZ2GN2S1-32T



NZ2GN2S1-32TE



NZ2GN2B1-32T



NZ2GN2B1-32TE



[40-pin connector]

NZ2GNCF1-32T



I/O combined module

[Spring-clamp terminal block]

NZ2GN2S1-32DT



NZ2GN2S1-32DTE



[Screw terminal block]

NZ2GN2B1-32DT



NZ2GN2B1-32DTE



[Sensor connector (e-CON)]

NZ2GNCE3-32DT



Analog input module

[Spring-clamp terminal block]

NZ2GN2S-60AD4



[Screw terminal block]

NZ2GN2B-60AD4



Analog output module

[Spring-clamp terminal block]

NZ2GN2S-60DA4



[Screw terminal block]

NZ2GN2B-60DA4



■ Waterproof/dustproof type (IP67) remote module

Input module

[Waterproof connector]

NZ2GN12A4-16D

NZ2GN12A4-16DE



Output module

[Waterproof connector]

NZ2GN12A2-16T

NZ2GN12A2-16TE



I/O combined module

[Waterproof connector]

NZ2GN12A42-16DT

NZ2GN12A42-16DTE



■ Industrial switching hub

Industrial switching hub

NZ2MHG-TSNT4

NZ2MHG-TSNT8F2



■ Tension controller

Tension meter

LM7-1LG, LM7-2LG



■ FPGA module

NZ2GN2S-D41P01/D01/PD02



■ Bridge module

CC-Link IE TSN-CC-Link IE
Field Network bridge module

NZ2GN-GFB



CC-Link IE TSN-AnyWireASLINK
bridge module

NZ2AW1GNAL



Servo system compatible with MELSEC MX Controller

The MELSERVO-J5 series servo system boasts industry-leading level basic performance. The high-speed, high-precision capabilities of MELSERVO-J5 help to increase the productivity of your machines.

Servo amplifier

MITSUBISHI ELECTRIC SERVO SYSTEM
MELSERVO-J5

MR-J5 series

Speed frequency response	Minimum communication cycle ^{*1}
3.5 kHz	31.25 μs



CC-Link IETSN
EtherCAT



MR-J5-G(-N1)

MR-J5W_G(-N1)

MR-J5D_G4(-N1)

Servo motor

▶ Rotary servo motor

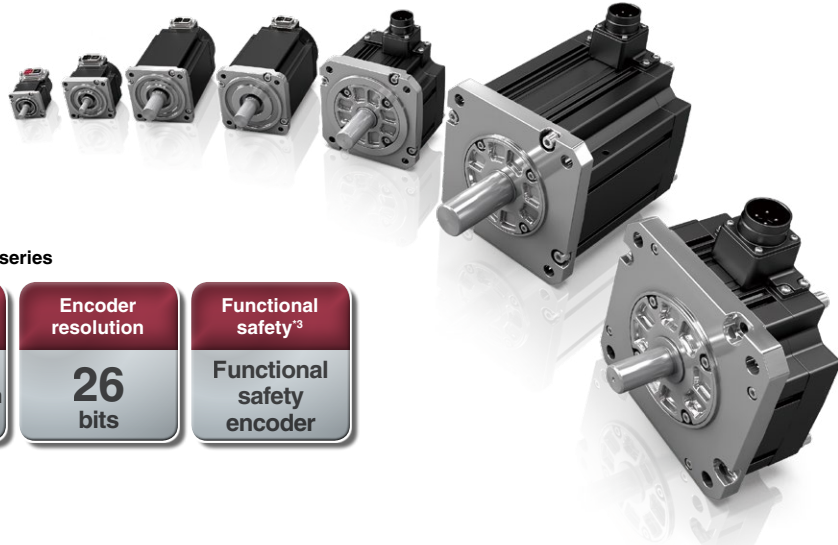

HK series

Max. speed ^{*1}	Encoder	Encoder resolution	Functional safety ^{*3}
10000 r/min	Batteryless absolute position encoder	26 bits	Functional safety encoder

▶ Linear servo motor



LM-H4M series

Max. speed	Linear servo motor	Max. number of connection
5.0 m/s	Module type	8 modules

*1: 31.25 μs applies to MR-J5-G/MR-J5D1-G4.

*2: 10000 r/min is supported by HK-MT_V (incremental encoder).

*3: Supported by HK_WS.

Tuning functions

Use the tuning methods that are optimal for your machines.

- Quick tuning
- One-touch tuning
- Advanced vibration suppression control II
- Command notch filter
- Machine resonance suppression filter

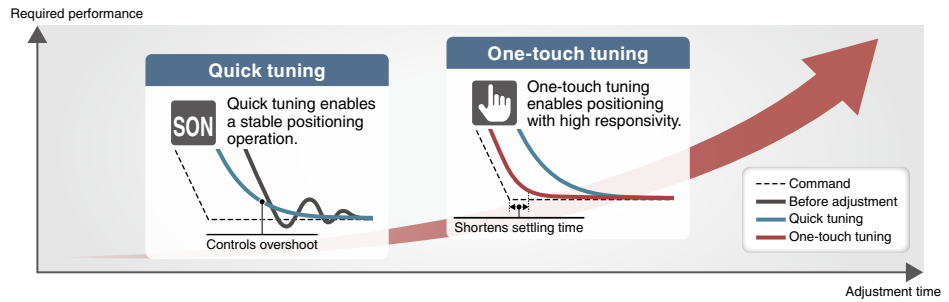

Preventive maintenance

» Machine diagnosis (ball screws, belts, gears)

This function detects aging degradation from friction and vibration in components such as ball screws, belts, and gears.

It automatically generates a failure warning limit, detects errors, and outputs a warning upon signs of failure.

Diagnostic results can be transferred to the IT system via CC-Link IE TSN for use in machine diagnostics and maintenance of the entire system.

Ball screw

Service life of the ball screw can be detected

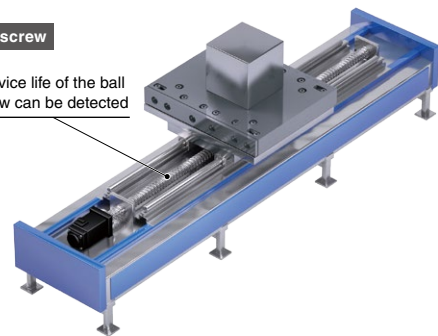

Corrective maintenance

» Drive recorder

This function continuously monitors the servo status and records the status transition such as a trigger condition before and after an alarm for a fixed period of time.

Reading the servo data on MR Configurator2 helps you analyze the cause of the alarm.

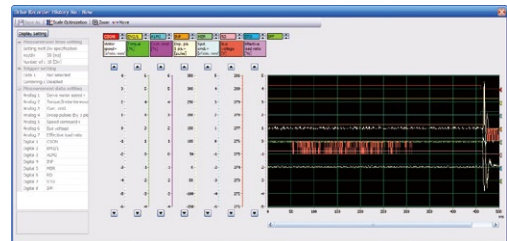

■ Lineup*1

Servo amplifier

MR-J5-G(4)



MR-J5W_G



MR-J5D_G4



Rotary servo motor

HK-KT



HK-MT



HK-ST



HK-RT



HK-JT



*1: Linear servo motors and direct drive motors are also available. For details, refer to the "AC Servo System MELSERVO-J5" (L03179ENG).

Variety of devices available through our partnerships with leading manufacturers

Drive motors from partner manufacturers with MELSERVO-J5

By using MELSERVO-J5, you can standardize your servo amplifiers and reduce the number of spare parts needed. Through cooperation with various partner manufacturers, suitable products can be chosen from various types of motors.¹

Partner motors



Akribis
where precision matters

Akribis Systems Pte Ltd



DGL/AXD Series



WITTENSTEIN
WITTENSTEIN Ltd.



axenia value Series



FUJI Linear

FUJI Linear



SLM Series



IKO

NIPPON THOMPSON CO.,LTD.



NT...V/SA...DE Series



MTL

Microtech Laboratory Co., Ltd.



µDD Series



THK

THK America, Inc.



GLM Series

Driven by
MELSERVO-J5



Combination with drive units from other manufacturers

The MELSEC MX Controller can work not only with MELSERVO but also with drive units from other manufacturers that support CC-Link IE TSN.²

Partner drives

CC-Link IE TSN



FASTECH
Fast Accurate Smooth Motion

FASTECH Co., Ltd

Ezi-SERVO Lineup







NPM

MABUCHI MOTOR
NPM Co., Ltd.

CLET-AD Series







IAI
Quality and Innovation

IAI CORPORATION.

RCON system



Partner devices



NSD Corporation

NSD Corporation

Encoder



Setting image



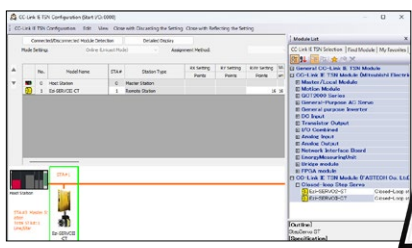



¹: For details on individual motor drives, please consult your local Mitsubishi Electric representative.

²: For information on devices with confirmed connectivity with MXF100-8-N32-EC and MXF100-16-N32-EC, contact your local Mitsubishi Electric representative.

60

Specifications/Function list

When adopting this product, please read the information in the product manual, including specifications, available modules, and restrictions.

General specifications

■ MX-R model

Item	Specifications				
Operating ambient temperature	0...55°C				
Storage ambient temperature	-25...75°C				
Operating ambient humidity	5...95% RH, non-condensing				
Storage ambient humidity	5...95% RH, non-condensing				
Vibration resistance	-	Frequency	Constant acceleration	Half amplitude	Number of sweeps
	Under intermittent vibration	5...8.4 Hz	-	3.5 mm	10 times each in X, Y, and Z directions
		8.4...150 Hz	9.8 m/s ²	-	
	Under continuous vibration	5...8.4 Hz	-	1.75 mm	
8.4...150 Hz		4.9 m/s ²	-		
IEC 61131-2: 2007/ JIS B 3502: 2011					
Shock resistance	Three shocks in each direction per axis, on 3 mutually perpendicular axes (total of 18 shocks)				
Operating atmosphere	No corrosive gases ⁴ and flammable gases, less conductive dust				
Operating altitude ¹	0...2000 m				
Installation location	Inside an indoor-use control panel				
Overvoltage category ²	II or less				
Pollution degree ³	2 or less				

*1: Do not use or store the controller under pressure higher than the atmospheric pressure of altitude 0 m. Doing so may cause malfunction.

*2: This indicates the section of the power supply to which the equipment is assumed to be connected between the public electrical power distribution network and the machinery within premises. Category II applies to equipment for which electrical power is supplied from fixed facilities.
The surge voltage withstand level for up to the rated voltage of 300 V is 2500 V.

*3: This index indicates the degree to which conductive material is generated in terms of the environment in which the equipment is used. Pollution degree 2 is when only non-conductive pollution occurs. A temporary conductivity caused by condensation must be expected occasionally.

*4: When using the controller in the environment with the corrosive gases, use the special coated products having improved resistance to the environment of a certain degree of corrosive gas concentration specified in IEC 60721-3-3: 1994 3C2.

For details on the special coated products, please consult your local Mitsubishi Electric representative.

■ MX-F model

Item	Specifications				
Operating ambient temperature ¹	0...55°C, non-freezing				
Storage ambient temperature	-25...75°C, non-freezing				
Operating ambient humidity	5...95% RH, non-condensing ²				
Storage ambient humidity	5...95% RH, non-condensing				
Vibration resistance ^{3,4}	-	Frequency	Constant acceleration	Half amplitude	Number of sweeps
	Installed on DIN rail	5...8.4 Hz	-	1.75 mm	10 times each in X, Y, and Z directions (total 80 minutes in each direction)
		8.4...150 Hz	4.9 m/s ²	-	
Shock resistance ⁵	147 m/s ² , Duration of action: 11 ms, 3 times each in X, Y, and Z bidirections by sine half-wave pulse				
Noise immunity	By noise simulator at noise voltage of 1000 Vp-p, noise width of 1 μs and period of 30...100 Hz				
Grounding	Grounding resistance of 100Ω or less (Common grounding with a heavy electrical system is not allowed) ⁶				
Operating atmosphere	No corrosive gases and flammable gases, less conductive dust				
Operating altitude ⁶	0...2000 m				
Installation location	Inside a control panel ⁷				
Overvoltage category ⁸	II or less				
Pollution degree ⁹	2 or less				

*1: Input/output derating is required. For details, refer to the manual.

*2: When used in a low-temperature environment, use in an environment with no sudden temperature changes. When there are sudden temperature changes because of opening/closing of the control panel or other reasons, condensation may occur, which may cause a fire, fault, or malfunction. Furthermore, use an air conditioner in dehumidifier mode to prevent condensation.

*3: The criterion is shown in IEC 61131-2.

*4: When the system has equipment which specification values are lower than above mentioned vibration resistance specification values, the vibration resistance specification of the whole system is corresponding to the lower specification.

*5: For details on the grounding, refer to the manual.

*6: The controller cannot be used at a pressure higher than the atmospheric pressure to avoid damage.

*7: The controller system is assumed to be installed in an environment equivalent to indoor.

*8: This indicates the section of the power supply to which the equipment is assumed to be connected between the public electrical power distribution network and the machinery within premises. Category II applies to equipment for which electrical power is supplied from fixed facilities.
The surge voltage withstand level for up to the rated voltage of 300 V is 2500 V.

*9: This index indicates the degree to which conductive material is generated in terms of the environment in which the equipment is used. Pollution degree 2 is when only non-conductive pollution occurs. A temporary conductivity caused by condensation must be expected occasionally.

Performance specifications

●: Supported, -: Not supported

Item	MXR300-16	MXR300-32	MXR300-64	MXR500-128	MXR500-256	MXF100-8-N32(-EC) MXF100-8-P32	MXF100-16-N32(-EC) MXF100-16-P32
Operation control method	Repetitive operation of stored programs						
I/O control mode	Refresh mode (The direct access input/output is available by specifying the direct access input/output (DX, DY).)						
Programming language	<ul style="list-style-type: none"> · Ladder diagram (LD) · Structured text (ST) · Function block diagram (FBD/LD) 						
Extended programming language	<ul style="list-style-type: none"> · Function block (FB) · Label programming 						
Program execution type	Initial, scan, fixed scan, interrupt, and standby						
Number of I/O points	4K points (4096 points)					512 points	
Memory capacity	Program memory	100 MB			150 MB	30 MB	
	Program cache memory	40 MB			80 MB	12 MB	
	Device/label memory	128 MB			256 MB	8 MB	
	Data memory	30 MB			60 MB	15 MB	
Online change	●						
Processing speed	Double-precision floating-point processing		0.63 ns...		0.46 ns...		2.50 ns...
	Instruction processing time	LD instruction	0.38 ns...		0.28 ns...		1.25 ns...
Number of occupied I/O points	64 points (CC-Link IE TSN function part: 32 points, motion function part: 32 points)					-	
Number of slots occupied by a module	3 slots					-	
Peripheral connection port							
USB port	USB 2.0 High Speed (Type-C) × 1						
Ethernet port	1000BASE-T/100BASE-TX × 1					- ^{*1,2}	
CC-Link IE TSN port/EtherCAT port ^{*3}	1000BASE-T/100BASE-TX × 2					1000BASE-T/100BASE-TX × 2 ^{*1,4}	
Memory interface							
SD memory card	SD/SDHC memory card						

*1: One of the CC-Link IE TSN ports can be switched to the Ethernet port.

*2: 1000BASE-T/100BASE-TX × 1 for MXF100-8-N32-EC and MXF100-16-N32-EC.

*3: EtherCAT port for MXF100-8-N32-EC and MXF100-16-N32-EC. CC-Link IE TSN port for the other models.

*4: 100BASE-TX × 1 for MXF100-8-N32-EC and MXF100-16-N32-EC.

Item		MXR300-16	MXR300-32	MXR300-64	MXR500-128	MXR500-256	MXF100-8-N32(-EC) MXF100-8-P32	MXF100-16-N32(-EC) MXF100-16-P32	
Motion control specifications									
Number of controllable axes	Real drive axis	16 axes	32 axes	64 axes	128 axes	256 axes	8 axes	16 axes	
Motion operation cycle [μs]		125, 250, 500, 1000, 1500, 2000, 2500, 3000, 3500, 4000, 4500, 5000, 5500, 6000, 6500, 7000, 7500, 8000					250, 500, 1000, 1500, 2000, 2500, 3000, 3500, 4000, 4500, 5000, 5500, 6000, 6500, 7000, 7500, 8000 ¹		
Servo amplifier connection		MR-J5-G, MR-J5W2-G, MR-J5W3-G, MR-J5D1-G4, MR-J5D2-G4, MR-J5D3-G4, TSN-compatible drive ² , MR-JET							
Absolute position control system		64 bit control/32 bit control							
Positioning range		64 bit floating-point (LREAL type)							
Interpolation function		Linear interpolation (4 axes maximum), 2-axis circular interpolation							
Control method		PTP control, speed control, speed-position switching control (future support), speed control/torque control/continuous operation to torque control, pressure control, multi-axis positioning data operation, position follow-up control, and motion cyclic instruction (position, velocity, and torque)					PTP control, speed control, speed-position switching control (future support), speed control/torque control/continuous operation to torque control ³ , pressure control (future support) ³ , multi-axis positioning data operation, position follow-up control, and motion cyclic instruction (position, velocity, and torque)		
Operation cycles mixed		3 groups							
System memory size		256 MB					96 MB		
Size of built-in ROM for user data		30 MB (Data memory is used.)			60 MB (Data memory is used.)		15 MB (Data memory is used.)		
		Real drive axis, virtual drive axis, real encoder axis, virtual encoder axis, and virtual linked axis							
Axis	Axes group	0: Not set 1...: Setting axes group No.							
	Real drive axis	Servo amplifier							
	Real encoder axis	Via a servo amplifier							
Compensation function		Driver unit conversion function and phase compensation function (future support)					Driver unit conversion function and phase compensation function (future support)		
Synchronous control	Instruction	Advanced synchronous control and cam operation start (MC_CamIn)							
	Module	Master axis, cam, gear, and clutch							
	Master axis	Real drive axis, virtual drive axis, real encoder axis, virtual encoder axis, and virtual linked axis							
Start/stop		Start, stop, restart, buffer mode, and forced stop							
Home position return	Home position return method	Driver home position return method (use the home position return method set in the driver)							
Positional control	Linear control	Linear interpolation (2...4 axes)							
	2-axis circular interpolation	Border point specification, center point specification, and radius specification							
Manual control		JOG operation							
Direct control	Speed control	Speed control not including position loop and speed control including position loop							
	Torque control	Torque control and continuous operation to torque control ³							
Absolute positioning system		Provided (batteryless)							
Function to limit control	Velocity limit	Velocity set range							
	Torque limit	Positive direction torque limit value, negative direction torque limit value							
	Forced stop	Enabled/disabled switching							
	Software stroke limit	Check the movable range at the set position and the machine feed value.							
	Hardware stroke limit	●							
Function to change control content	Set velocity change	●							
	Current value change	●							
	Acceleration/deceleration process change	Acceleration/deceleration and acceleration/deceleration time							
	Torque limit value change	●							
	Target position change	Target position change and movement distance change							
	Override	●							
	History data	Position data history							
Function	Axis emulation	●							
	Touch probe (mark detection)	●							
	Monitoring of servo data	Cyclic transmission and transient transmission ⁴							
	Servo system recorder	Future support					-		
	Digital cam switch	●					● ³		
Operation profile data (cam) specifications									
Number of registrations		60000 maximum (settable number from engineering tool: 1024)							
Cam data	Type	Cam data and rotary knife							
	Interpolation method	Specifying for each section, linear interpolation, and spline interpolation							
	Profile ID	1...60000							
	Resolution	8...65535 (optional)							
	Unit of length per cycle setting	mm, inch, pulse, degree							
Unit of stroke amount		%, mm, inch, pulse, degree							
Cam auto-generation		Cam auto-generation cam for rotary knife							

¹: 250, 500, 1000, 2000, 4000, 8000 for MXF100-8-N32-EC and MXF100-16-N32-EC.

²: MR-J5-G-N1, MR-J5D1-G4-N1, and EtherCAT-compatible drives for MXF100-8-N32-EC and MXF100-16-N32-EC. Multi-axis drive unit operation including MR-J5W2-G-N1 and MR-J5W3-G-N1 will be supported in the future.

³: MXF100-8-N32-EC and MXF100-16-N32-EC are not supported.

⁴: SDO communication and PDO communication for MXF100-8-N32-EC and MXF100-16-N32-EC.

Network (CC-Link IE TSN) specifications

Item		MXR300-16	MXR300-32	MXR300-64	MXR500-128	MXR500-256	MXF100-8-N32 MXF100-8-P32	MXF100-16-N32 MXF100-16-P32	
Transmission speed		1 Gbps/100 Mbps							
Maximum number of connectable stations per network		254 stations (manager station: 1, device station: 253 ^{*1}) ²					39 stations (manager station: 1, device station: 38)	47 stations (manager station: 1, device station: 46)	
Network topology		Line topology, star topology, coexistence of line and star topologies, ring topology					Line topology, star topology, coexistence of line and star topologies		
Overall cable length	Line connection	25300 m (when 254 stations are connected)					3800 m (when 39 stations are connected)	4600 m (when 47 stations are connected)	
	Others	Depends on the system configuration.							
Maximum station-to-station distance		100 m							
Maximum number of link points per network	RX/Ry	16K points (16384 points, 2 KB) for each							
	RWr/RWw	8K points (8192 points, 16 KB) for each							
	LB (future support)	32K points (32768 points, 4 KB)						-	
	LW (future support)	16K points (16384 points, 32 KB)						-	
Maximum number of link points per station	RX/Ry	16K points (16384 points, 2 KB) for each					Manager station: 8K points (8192 points, 1 KB) for each		
	RWr/RWw	8K points (8192 points, 16 KB) for each					Manager station: 4K points (4096 points, 8 KB) for each		
Connection cable		Ethernet cable (Category 5e or higher)							
Communication method		Time sharing method							
Transient transmission capacity		Maximum 1920 bytes							

*1: The maximum number of connectable stations becomes 256 when modules that operate as extension modules, such as a multiple-axes drive unit, are included in the number.

*2: Device stations supporting connections to 253 stations will be available in the future. For details, refer to the Technical Bulletin (FA-A-0451).

Network (EtherCAT) specifications^{*1}

Item		MXF100-8-N32-EC		MXF100-16-N32-EC
EtherCAT communication specifications		CAN application protocol over EtherCAT (CoE)		
Type		MainDevice		
Transmission speed		100 Mbps		
Maximum number of connected stations per network		73 stations (MainDevice: 1, SubDevice: 72)		
Network topology		Line topology, star topology		
Overall cable length	Line topology	7200 m (when 73 stations are connected)		
	Others	Depends on the system configuration		
Maximum station-to-station distance		100 m		
PDO (process data communication)	Maximum number of link points per network	Input	8192 points (8192 words)	
		Output	8192 points (8192 words)	
	Maximum number of link points per station	Input	8192 points (8192 words)	
		Output	8192 points (8192 words)	
SDO (mailbox communication)	Size	Input	400 words	
		Output	400 words	
	Function	SDO Upload, SDO Download		
Communication method		Full-duplex		

*1: For EtherCAT SubDevices with confirmed connectivity, refer to "Programmable Automation Controllers MELSEC MX Controller" (L(NA)0810011ENG).

Function list

●: Supported, -: Not supported

Item		MX-R model	MX-F model
General	Data logging function	●	●
	SLMP communication	●	●
	Firmware update function	●	●
	Event history function	●	●
	Backup/restoration	●	●
	Inter-module synchronization function	Future support	-
Engineering	Multiple interrupt	●	●
Maintenance	Realtime monitor	●	●
	Web server	●	Future support
Network	File transfer function (FTP server)	●	●
	File transfer function (FTP client)	●	●
	Simple CPU communication	●	● ^{*1,2}
	CC-Link IE Field Basic		Future support
	MQTT		Future support
Information linkage/security	User authentication function	●	●
	Encrypted communication function	●	●
	OPC UA server function	●	●
	OPC UA client function		Future support
	Recording function	●	Future support
	Network drive function	●	Future support
Built-in high-speed input/output	Pulse train positioning	-	●
	High-speed counter	-	●

*1: Only MX-F model also supports MODBUS/TCP.

*2: MXF100-8-N32-EC and MXF100-16-N32-EC will be supported in the future.

MX-R model power supply module specifications

-: Not supported

Item	Power supply module					Redundant power supply module		
	R61P	R62P	R63P	R64P	R69P	R63RP	R64RP	R69RP
Input power supply voltage [V]	100...240 V AC (85...264 V AC)	100...240 V AC (85...264 V AC)	24 V DC (15.6...31.2 V DC)	100...240 V AC (85...264 V AC)	24 V DC (19.2...31.2 V DC)	24 V DC (19.2...31.2 V DC)	100...240 V AC (85...264 V AC)	24 V DC (19.2...31.2 V DC)
Input frequency	50/60 Hz ±5%	50/60 Hz ±5%	-	50/60 Hz ±5%	-	-	50/60 Hz ±5%	-
Maximum input apparent power [VA]	130	120	-	160	-	-	160	-
Maximum input power [W]	-	-	50	-	65	50	-	65
Rated output current (5 V DC) [A]	6.5	3.5	6.5	9	9	6.5	9	9
Rated output current (24 V DC) [A]	-	0.6	-	-	-	-	-	-

MX-F model power supply specifications

Item	Specifications
Rated voltage	24 V DC
Voltage fluctuation range	+20%, -15%
Allowable momentary power failure time	5 ms or less (at 24 V)
Power fuse	125 V, 3.15 A time-lag fuse
Inrush current	100 A, 0.06 ms or less 4.0 A, 350 ms or less
Power consumption	Controller alone: 13.6 W or less Maximum configuration for connection to the controller: 32.0 W or less (external 24 V DC power supply of extension devices is not included)
24 V DC built-in power supply capacity	500 mA
5 V DC built-in power supply capacity	720 mA

Product list

MELSEC MX Controller

Product name	Model	Overview
MX-R model	MXR300-16	Program memory: 100 MB, maximum number of controllable axes: 16 axes, built-in CC-Link IE TSN
	MXR300-32	Program memory: 100 MB, maximum number of controllable axes: 32 axes, built-in CC-Link IE TSN
	MXR300-64	Program memory: 100 MB, maximum number of controllable axes: 64 axes, built-in CC-Link IE TSN
	MXR500-128	Program memory: 150 MB, maximum number of controllable axes: 128 axes, built-in CC-Link IE TSN
	MXR500-256	Program memory: 150 MB, maximum number of controllable axes: 256 axes, built-in CC-Link IE TSN
MX-F model	MXF100-8-N32	Program memory: 30 MB, maximum number of controllable axes: 8 axes, built-in CC-Link IE TSN Input: 16 points, transistor (sink) output: 16 points
	MXF100-8-P32	Program memory: 30 MB, maximum number of controllable axes: 8 axes, built-in CC-Link IE TSN Input: 16 points, transistor (source) output: 16 points
	MXF100-16-N32	Program memory: 30 MB, maximum number of controllable axes: 16 axes, built-in CC-Link IE TSN Input: 16 points, transistor (sink) output: 16 points
	MXF100-16-P32	Program memory: 30 MB, maximum number of controllable axes: 16 axes, built-in CC-Link IE TSN Input: 16 points, transistor (source) output: 16 points
	MXF100-8-N32-EC	Program memory: 30 MB, maximum number of controllable axes: 8 axes, built-in EtherCAT Input: 16 points, transistor (sink) output: 16 points
	MXF100-16-N32-EC	Program memory: 30 MB, maximum number of controllable axes: 16 axes, built-in EtherCAT Input: 16 points, transistor (sink) output: 16 points

Common options

Product name	Model	Overview
SD memory card	NZ1MEM-2GBSD	SD memory card, 2 GB
	NZ1MEM-4GBSD	SDHC memory card, 4 GB
	NZ1MEM-8GBSD	SDHC memory card, 8 GB
	NZ1MEM-16GBSD	SDHC memory card, 16 GB
Battery	FX3U-32BL	Battery for long-time backup of the clock data

■ List of devices that support MX-R model

Product name	Model	Overview
Base unit		
Main base	R33B	3 slots, for MELSEC iQ-R Series module installation
	R35B	5 slots, for MELSEC iQ-R Series module installation
	R38B	8 slots, for MELSEC iQ-R Series module installation
	R312B	12 slots, for MELSEC iQ-R Series module installation
Extension base	R65B	5 slots, for MELSEC iQ-R Series module installation
	R68B	8 slots, for MELSEC iQ-R Series module installation
	R612B	12 slots, for MELSEC iQ-R Series module installation
Extended temperature range extension base	R610B-HT	10 slots, for MELSEC iQ-R Series module installation, operating ambient temperature: 0...60°C
Extension cable	RC06B	0.6 m cable, for extension base unit connection
	RC12B	1.2 m cable, for extension base unit connection
	RC30B	3 m cable, for extension base unit connection
	RC50B	5 m cable, for extension base unit connection
	RC100B	10 m cable, for extension base unit connection
Power supply module		
Power supply	R61P	AC power supply module, input: 100...240 V AC, output: 5 V DC/6.5 A
	R62P ^{*1}	AC power supply module, input: 100...240 V AC, output: 5 V DC/3.5 A, 24 V DC/0.6 A
	R63P	DC power supply module, input: 24 V DC, output: 5 V DC/6.5 A
	R64P	AC power supply module, input: 100...240 V AC, output: 5 V DC/9 A
	R69P	DC power supply module, input: 24 V DC, output: 5 V DC/9 A
Redundant power supply	R63RP	DC power supply module, input: 24 V DC, output: 5 V DC/6.5 A, for redundant power supply system
	R64RP	AC power supply module, input: 100...240 V AC, output: 5 V DC/9 A, for redundant power supply system
	R69RP	DC power supply module, input: 24 V DC, output: 5 V DC/9 A, for redundant power supply system
I/O module		
AC input	RX10	16 points, 100...120 V AC (50/60 Hz), screw terminal block
	RX10-TS	16 points, 100...120 V AC (50/60 Hz), spring-clamp terminal block
	RX28	8 points, 100...240 V AC (50/60 Hz), screw terminal block
DC input	RX40C7	16 points, 24 V DC (input current: 7.0 mA), positive/negative common shared type, screw terminal block
	RX41C4	32 points, 24 V DC (input current: 4.0 mA), positive/negative common shared type, 40-pin connector
	RX42C4	64 points, 24 V DC (input current: 4.0 mA), positive/negative common shared type, 40-pin connector × 2
	RX40C7-TS	16 points, 24 V DC (input current: 7.0 mA), positive/negative common shared type, spring-clamp terminal block
	RX41C4-TS	32 points, 24 V DC (input current: 4.0 mA), positive/negative common shared type, spring-clamp terminal block
	RX70C4	16 points, 5 V DC (input current: 1.7 mA), 12 V DC (input current: 4.8 mA), positive/negative common shared type, screw terminal block
	RX71C4	32 points, 5 V DC (input current: 1.7 mA), 12 V DC (input current: 4.8 mA), positive/negative common shared type, 40-pin connector
	RX72C4	64 points, 5 V DC (input current: 1.7 mA), 12 V DC (input current: 4.8 mA), positive/negative common shared type, 40-pin connector × 2
DC high-speed input	RX40PC6H	16 points, 24 V DC (input current: 6.0 mA), minimum response time: 5 μs, positive common, screw terminal block
	RX40NC6H	16 points, 24 V DC (input current: 6.0 mA), minimum response time: 5 μs, negative common, screw terminal block
	RX41C6HS	32 points, 24 V DC (input current: 6.0 mA), minimum response time: 1 μs, positive/negative common shared type, 40-pin connector
	RX61C6HS	32 points, 5 V DC (input current: 6.0 mA), minimum response time: 1 μs, positive/negative common shared type, 40-pin connector
Input with diagnostic functions	RX40NC6B	16 points, 24 V DC (input current: 6.0 mA), negative common, screw terminal block
Contact output	RY10R2	16 points, 24 V DC 2 A/point, 240 V AC 2 A/point, screw terminal block
	RY10R2-TS	16 points, 24 V DC 2 A/point, 240 V AC 2 A/point, spring-clamp terminal block
	RY18R2A	8 points, 24 V DC 2 A/point, 240 V AC 2 A/point, screw terminal block
Triac output	RY20S6	16 points, 100...240 V AC, screw terminal block
Transistor output	RY40NT5P	Transistor (sink) output: 16 points, 12/24 V DC, screw terminal block
	RY41NT2P	Transistor (sink) output: 32 points, 12/24 V DC, 40-pin connector
	RY42NT2P	Transistor (sink) output: 64 points, 12/24 V DC, 40-pin connector × 2
	RY40PT5P	Transistor (source) output: 16 points, 12/24 V DC, screw terminal block
	RY41PT1P	Transistor (source) output: 32 points, 12/24 V DC, 40-pin connector
	RY42PT1P	Transistor (source) output: 64 points, 12/24 V DC, 40-pin connector × 2
	RY40NT5P-TS	Transistor (sink) output: 16 points, 12/24 V DC, spring-clamp terminal block
	RY41NT2P-TS	Transistor (sink) output: 32 points, 12/24 V DC, spring-clamp terminal block
	RY40PT5P-TS	Transistor (source) output: 16 points, 12/24 V DC, spring-clamp terminal block
	RY41PT1P-TS	Transistor (source) output: 32 points, 12/24 V DC, spring-clamp terminal block
	Transistor high-speed output	RY41NT2H
RY41PT2H		Transistor (source) output: 32 points, 5/12/24 V DC, minimum response time: 2 μs, 40-pin connector
Output with diagnostic functions	RY40PT5B	Transistor (source) output: 16 points, 24 V DC, screw terminal block
I/O combined	RH42C4NT2P	DC input: 32 points, 24 V DC (input current: 4.0 mA), positive/negative common shared type, transistor (sink) output: 32 points, 12/24 V DC, 40-pin connector × 2

*1: MXR500□: Can be used only on the extension base unit.

MXR300□: Can be used on the R33B, R35B, and extension base unit.

Product name	Model	Overview
Analog module		
Analog-digital conversion	R60AD4	Voltage/current input: 4 channels, -10...10 V DC/-32000...32000, 0...20 mA DC/0...32000, 80 µs/channel, screw terminal block
	R60ADI8 R60ADV8	Current input: 8 channels, 0...20 mA DC/0...32000, 80 µs/channel, screw terminal block Voltage input: 8 channels, -10...10 V DC/-32000...32000, 80 µs/channel, screw terminal block
High-speed analog-digital conversion	R60ADH4	Voltage/current input: 4 channels, -10...10 V DC/-32000...32000, 0...20 mA DC/0...32000, 1 µs/channel, screw terminal block
Channel isolated analog-digital conversion	R60AD8-G	Voltage/current input: 8 channels, channel isolated, -10...10 V DC/-32000...32000, 0...20 mA DC/0...32000, 10 ms/channel, 40-pin connector
	R60AD16-G	Voltage/current input: 16 channels, channel isolated, -10...10 V DC/-32000...32000, 0...20 mA DC/0...32000, 10 ms/channel, 40-pin connector x 2
Channel isolated analog input module	R60AD6-DG	Current input: 6 channels, channel isolated, 4...20 mA DC (when connected to a 2-wire transmitter)/0...32000, 0...20 mA DC/0...32000, 10 ms/channel, 40-pin connector
Digital-analog conversion	R60DA4	Voltage/current output: 4 channels, -32000...32000/-10...10 V DC, 0...32000/0...20 mA DC, 80 µs/channel, screw terminal block
	R60DAI8	Current output: 8 channels, 0...32000/0...20 mA DC, 80 µs/channel, screw terminal block
	R60DAV8	Voltage output: 8 channels, -32000...32000/-10...10 V DC, 80 µs/channel, screw terminal block
High-speed digital-analog conversion	R60DAH4	Voltage/current output: 4 channels, -32000...32000/-10...10 V DC, 0...32000/0...20 mA DC, 1 µs/channel, screw terminal block
Channel isolated digital-analog conversion	R60DA8-G	Voltage/current output: 8 channels, channel isolated, -32000...32000/-12...12 V DC, 0...32000/0...20 mA DC, 1 ms/channel, 40-pin connector
	R60DA16-G	Voltage/current output: 16 channels, channel isolated, -32000...32000/-12...12 V DC, 0...32000/0...20 mA DC, 1 ms/channel, 40-pin connector x 2
Temperature input module, temperature control module		
Channel isolated thermocouple input	R60TD8-G	Thermocouple (B, R, S, K, E, J, T, and N), input: 8 channels, channel isolated, 30 ms/channel, 40-pin connector
Channel isolated RTD input	R60RD8-G	RTD (Pt100, JPt100, Ni100, and Pt50), input: 8 channels, channel isolated, 10 ms/channel, 40-pin connector
Temperature control	R60CTRT2TT2	Thermocouple (B, R, S, K, E, J, T, N, U, L, PLII, and W5Re/W26Re), input: 4 channels (RTD input can also be used for 2 channels), screw terminal block
	R60CTRT2TT2BW	Thermocouple (B, R, S, K, E, J, T, N, U, L, PLII, and W5Re/W26Re), input: 4 channels (RTD input can also be used for 2 channels), heater disconnection detection, screw terminal block
	R60TCRT4	RTD (Pt100 and JPt100), input: 4 channels, screw terminal block
	R60TCRT4BW	RTD (Pt100 and JPt100), input: 4 channels, heater disconnection detection, screw terminal block
	R60CTRT2TT2-TS	Thermocouple (B, R, S, K, E, J, T, N, U, L, PLII, and W5Re/W26Re), input: 4 channels (RTD input can also be used for 2 channels), spring-clamp terminal block
	R60TCRT4-TS	RTD (Pt100 and JPt100), input: 4 channels, spring-clamp terminal block
High-speed counter, isolated pulse input, flexible high-speed I/O control module		
High-speed counter	RD62P2	5/12/24 V DC input: 2 channels, maximum counting speed: 200k pulse/s, external output: transistor (sink) output
	RD62D2	Differential input: 2 channels, maximum counting speed: 8M pulse/s, external output: transistor (sink) output
	RD62P2E	5/12/24 V DC input: 2 channels, maximum counting speed: 200k pulse/s, external output: transistor (sink) output
Channel isolated pulse input	RD60P8-G	5/12...24 V DC input: 8 channels, channel isolated, maximum counting speed: 30k pulse/s
Flexible high-speed I/O control	RD40PD01	Input: 12 points (5 V DC/24 V DC/differential common), maximum counting speed: 8M pulse/s (differential), output: 14 points (5...24 V DC: 8 points, differential: 6 points), maximum output pulse: 8M pulse/s (differential)
Positioning module		
Positioning	RD75P2	Open collector output: 2 axes, maximum output pulse: 200k pulse/s, linear interpolation, circular interpolation
	RD75P4	Open collector output: 4 axes, maximum output pulse: 200k pulse/s, linear interpolation, circular interpolation, helical interpolation
	RD75D2	Differential driver output: 2 axes, maximum output pulse: 5M pulse/s, linear interpolation, circular interpolation
	RD75D4	Differential driver output: 4 axes, maximum output pulse: 5M pulse/s, linear interpolation, circular interpolation, helical interpolation
Information module		
Ethernet interface with built-in CC-Link IE	RJ71EN71	1 Gbps/100 Mbps/10 Mbps: 2 ports Multiple networks compatible (Ethernet/CC-Link IE Field Network, CC-Link IE Controller Network (twisted pair cable))
Serial communication	RJ71C24	230.4 Kbps maximum, RS-232: 1 channel, RS-422/485: 1 channel
	RJ71C24-R2	230.4 Kbps maximum, RS-232: 2 channels
	RJ71C24-R4	230.4 Kbps maximum, RS-422/485: 2 channels
MES interface	RD81MES96N	Linked with database ¹
GP-IB interface	RJ71GB91	GP-IB system compatible controller/device
Camera recorder	RD81RC96-CA	Device and label collection, camera image
Network module		
CC-Link IE TSN	RJ71GN11-T2	1 Gbps/100 Mbps, manager station/local station
	RJ71GN11-SX	1 Gbps, optical fiber cable, manager station/local station
	RJ71GN11-EIP	1 Gbps/100 Mbps, manager station/local station, EtherNet/IP™ compatible, scanner
CC-Link IE Controller Network	RJ71GP21-SX	1 Gbps, optical fiber cable, control station/normal station, standard type
	RJ71GP21S-SX	1 Gbps, optical fiber cable, control station/normal station, with external power supply function
CC-Link IE Field Network	RJ71GF11-T2	1 Gbps, manager station/local station
CC-Link system master/local	RJ61BT11	10 Mbps maximum, manager station/local station, CC-Link Ver.2 compatible
AnyWireASLINK master	RJ51AW12AL	AnyWireASLINK system compatible, master station
CANopen®	RJ71CN91	CANopen® system compatible, NMT master/NMT slave
DeviceNet master/slave	RJ71DN91	DeviceNet® system compatible, master/slave
BACnet®	RJ71BAC96	BACnet® system compatible, controller/workstation
Ethernet/IP™	RJ71GN11-EIP	1Gbps/100Mbps CC-Link IE TSN, master station/local station, EtherNet/IP™ compatible, scanner
Energy measuring module		
Energy measuring	RE81WH	Energy measuring: 1 circuit, data refreshing cycle: 10 to 10000 ms (can be set in increments of 10 ms) ²
Blank cover module		
Blank cover	RG60	Blank cover for main base unit and extension base unit I/O slot

¹: The MX MESInterface-R (SW1DND-RMESIF) is required additionally.

²: A dedicated split-type current sensor is required additionally.

■ List of devices that support MX-F model

Product name	Model	Overview
I/O module for MX-F model	MXF100-X32	Input module, input: 32 points, sink/source shared type, spring-clamp terminal block
	MXF100-Y16R	Output module, output: 16 points, relay output, spring-clamp terminal block
	MXF100-Y32N	Output module, output: 32 points, transistor (sink) output, spring-clamp terminal block
	MXF100-Y32P	Output module, output: 32 points, transistor (source) output, spring-clamp terminal block
	MXF100-H32N	I/O module, input: 16 points, sink/source shared type, output: 16 points, transistor (sink) output, spring-clamp terminal block
MXF100-H32P	I/O module, input: 16 points, sink/source shared type, output: 16 points, transistor (source) output, spring-clamp terminal block	
I/O module ^{*1}		
Input	FX5-8EX/ES	Input module, input: 8 points, sink/source shared type, screw terminal block
	FX5-16EX/ES	Input module, input: 16 points, sink/source shared type, screw terminal block
Output	FX5-8EYR/ES	Output module, output: 8 points, relay output, screw terminal block
	FX5-16EYR/ES	Output module, output: 16 points, relay output, screw terminal block
	FX5-8EYT/ES	Output module, output: 8 points, transistor (sink) output, screw terminal block
	FX5-16EYT/ES	Output module, output: 16 points, transistor (sink) output, screw terminal block
	FX5-8EYT/ESS	Output module, output: 8 points, transistor (source) output, screw terminal block
FX5-16EYT/ESS	Output module, output: 16 points, transistor (source) output, screw terminal block	
Input/output	FX5-16ER/ES	I/O module, input: 8 points, sink/source shared type, output: 8 points, relay output, screw terminal block
	FX5-16ET/ES	I/O module, input: 8 points, sink/source shared type, output: 8 points, transistor (sink) output, screw terminal block
	FX5-16ET/ESS	I/O module, input: 8 points, sink/source shared type, output: 8 points, transistor (source) output, screw terminal block
Powered I/O	FX5-32ER/DS	Rated voltage 24 V DC, I/O module, input: 16 points, sink/source shared type, output: 16 points, relay output, screw terminal block
	FX5-32ET/DS	Rated voltage 24 V DC, I/O module, input: 16 points, sink/source shared type, output: 16 points, transistor (sink) output, screw terminal block
	FX5-32ET/DSS	Rated voltage 24 V DC, I/O module, input: 16 points, sink/source shared type, output: 16 points, transistor (source) output, screw terminal block
High-speed pulse input/output	FX5-16ET/ES-H	High-speed counter: 2 channels, pulse train: 2 axes, input: 8 points, sink/source shared type, output: 8 points, transistor (sink) output, screw terminal block
	FX5-16ET/ESS-H	High-speed counter: 2 channels, pulse train: 2 axes, input: 8 points, sink/source shared type, output: 8 points, transistor (source) output, screw terminal block
Extension power supply unit		
Extension power supply	FX5-C1PS-5V	Power supply for extension
Intelligent function module ^{*1}		
High-speed counter	FX5-2HC/ES	High-speed counter: 2 channels, input type: differential line driver, spring-clamp terminal block type
Analog input	FX5-4AD	Analog input: 4 channels, spring-clamp terminal block type
Analog output	FX5-4DA	Analog output: 4 channels, spring-clamp terminal block type
Multiple input	FX5-8AD	Multiple inputs (voltage, current, thermocouple, and RTD): 8 channels, spring-clamp terminal block type
Temperature control	FX5-4LC	Input (thermocouple, RTD, and low voltage input): 4 points, input (current detector): 4 points Output (open collector transistor output): 4 points, spring-clamp terminal block type
Ethernet	FX5-ENET	Ethernet module, CC-Link IE Field Network Basic
	FX5-ENET/IP	Ethernet module, EtherNet/IP™ system compatible, scanner, EtherNet/IP communication function: Class1 instance communications, Class3 message communications, UCMM message communications
EtherNet/IP™	FX5-EIP	EtherNet/IP™ system compatible, scanner, EtherNet/IP communication function: Class1 instance communications, Class1 tag communications, Class3 message communications, Class3 tag communications, UCMM message communications, UCMM tag communications
CC-Link IE TSN master/local	FX5-CCLGN-MS	CC-Link IE TSN manager station, CC-Link IE TSN local station
CC-Link system master/intelligent device	FX5-CCL-MS	CC-Link manager station, CC-Link intelligent device station
Connector conversion module		
Connector conversion	FX5-CNV-IFC	Connector conversion module to connect an extension device from FX5 (extension connector type) to FX5 (extension cable type)
Extension cable		
Extension cable	FX5-30EC	Extension cable for extension module (0.3 m)
	FX5-65EC	Extension cable for extension module (0.65 m)
Conversion adapter		
Connector conversion	FX5-CNV-BC	Conversion adapter
Expansion adapter		
Analog I/O	FX5-4A-ADP	Analog input: 2 channels, analog output: 2 channels European-type terminal block type
Analog input	FX5-4AD-ADP	Analog input: 4 channels European-type terminal block type
Analog output	FX5-4DA-ADP	Analog output: 4 channels European-type terminal block type
RTD temperature sensor input	FX5-4AD-PT-ADP	RTD temperature sensor input: 4 channels European-type terminal block type
Thermocouple temperature sensor input	FX5-4AD-TC-ADP	Thermocouple temperature sensor input: 4 channels European-type terminal block type
RS-232 communication	FX5-232ADP	RS-232C communication D-sub 9-pin type
RS-485 communication	FX5-485ADP	RS-485 communication European-type terminal block type

*1: When using the extension cable type module, the FX5-CNV-IFC or FX5-C1PS-5V is required.

■ List of CC-Link IETSN connection devices

Product name	Model	Overview
Block type remote module		
Input	NZ2GN2S1-16D	16 points, 24 V DC, input response time: 0...70 ms, positive/negative common shared type, spring-clamp terminal block, 1-wire type
	NZ2GN2S1-32D	32 points, 24 V DC, input response time: 0...70 ms, positive/negative common shared type, spring-clamp terminal block, 1-wire type
	NZ2GN2B1-16D	16 points, 24 V DC, input response time: 0...70 ms, positive/negative common shared type, screw terminal block, 1-wire type
	NZ2GN2B1-32D	32 points, 24 V DC, input response time: 0...70 ms, positive/negative common shared type, screw terminal block, 1-wire type
	NZ2GNCE3-32D	32 points, 24 V DC, input response time: 0...70 ms, positive common, sensor connector (e-CON), 3-wire type
	NZ2GNCF1-32D	32 points, 24 V DC, input response time: 0...70 ms, positive/negative common shared type, 40-pin connector, 1-wire type
Output	NZ2GN2S1-16T	16 points, 12/24 V DC, sink, spring-clamp terminal block, 1-wire type
	NZ2GN2S1-16TE	16 points, 12/24 V DC, source, spring-clamp terminal block, 1-wire type
	NZ2GN2S1-32T	32 points, 12/24 V DC, sink, spring-clamp terminal block, 1-wire type
	NZ2GN2S1-32TE	32 points, 12/24 V DC, source, spring-clamp terminal block, 1-wire type
	NZ2GN2B1-16T	16 points, 12/24 V DC, sink, screw terminal block, 1-wire type
	NZ2GN2B1-16TE	16 points, 12/24 V DC, source, screw terminal block, 1-wire type
	NZ2GN2B1-32T	32 points, 12/24 V DC, sink, screw terminal block, 1-wire type
	NZ2GN2B1-32TE	32 points, 12/24 V DC, source, screw terminal block, 1-wire type
NZ2GNCF1-32T	32 points, 12/24 V DC, sink, 40-pin connector, 1-wire type	
I/O combined	NZ2GN2S1-32DT	Input: 16 points, 24 V DC, input response time: 0...70 ms, positive common Output: 16 points, 24 V DC, sink, spring-clamp terminal block, 1-wire type
	NZ2GN2S1-32DTE	Input: 16 points, 24 V DC, input response time: 0...70 ms, negative common Output: 16 points, 24 V DC, source, spring-clamp terminal block, 1-wire type
	NZ2GN2B1-32DT	Input: 16 points, 24 V DC, input response time: 0...70 ms, positive common Output: 16 points, 24 V DC, sink, screw terminal block, 1-wire type
	NZ2GN2B1-32DTE	Input: 16 points, 24 V DC, input response time: 0...70 ms, negative common Output: 16 points, 24 V DC, source, screw terminal block, 1-wire type
Analog input	NZ2GN2S-60AD4	4 channels, input: -10...10 V DC, 0...20 mA DC Conversion speed: 200 μs/channel, spring-clamp terminal block
	NZ2GN2B-60AD4	4 channels, input: -10...10 V DC, 0...20 mA DC Conversion speed: 200 μs/channel, screw terminal block
Analog output	NZ2GN2B-60DA4	4 channels, output: -10...10 V DC, 0...20 mA DC Conversion speed: 200 μs/channel, spring-clamp terminal block
	NZ2GN2S-60DA4	4 channels, output: -10...10 V DC, 0...20 mA DC Conversion speed: 200 μs/channel, screw terminal block
Waterproof/dustproof type (IP67) remote module		
Input	NZ2GN12A4-16D	16 points, 24 V DC, input response time: 0...70 ms, positive common, waterproof connector, 2...4-wire type
	NZ2GN12A4-16DE	16 points, 24 V DC, input response time: 0...70 ms, negative common, waterproof connector, 2...4-wire type
Output	NZ2GN12A2-16T	16 points, 12/24 V DC, transistor, sink, waterproof connector, 2-wire type
	NZ2GN12A2-16TE	16 points, 12/24 V DC, transistor, source, waterproof connector, 2-wire type
I/O combined	NZ2GN12A42-16DT	Input: 8 points, 24 V DC, input response time: 0...70 ms, positive common, 2...4-wire type Output: 8 points, 12/24 V DC, sink, 2-wire type, waterproof connector
	NZ2GN12A42-16DTE	Input: 8 points, 24 V DC, input response time: 0...70 ms, negative common, 2...4-wire type Output: 8 points, 12/24 V DC, source, 2-wire type, waterproof connector
Industrial switching hub		
Industrial switching hub	NZ2MHG-TSNT4	Industrial switching hub
	NZ2MHG-TSNT8F2	
CC-Link IE TSN-compatible bridge module		
Bridge	NZ2GN-GFB	CC-Link IE TSN-CC-Link IE Field Network bridge module
	NZ2AW1GNAL	CC-Link IE TSN-AnyWireASLINK bridge module
CC-Link IE TSN-compatible FPGA module		
DC input/output	NZ2GN2S-D41P01	Input: 48 points, 24 V DC, input response time: 1 μs or less, positive/negative common shared type Output: 48 points, 5/12/24 V DC, sink
Differential input/output	NZ2GN2S-D41D01	Differential (RS-422) input: 24 points, input response time: 0.2 μs or less Differential (RS-422) output: 24 points Differential (RS-485) input/output: 3 points
DC input/output, differential input/output	NZ2GN2S-D41PD02	Input: 32 points, 24 V DC, input response time: 1 μs or less, positive/negative common shared type Output: 32 points, 5/12/24 V DC, sink Differential (RS-422) input: 8 points, input response time: 0.2 μs or less Differential (RS-422) output: 8 points Differential (RS-485) input/output: 1 point
Tension meter		
Tension meter	LM7-1LG	Power input: 24 V DC, detector input: 1 axis
	LM7-2LG	Power input: 24 V DC, detector input: 2 axes

Software MELSOFT - Engineering software

Product name	Overview
MELSOFT iQ Works	<ul style="list-style-type: none"> FA engineering software^{*1} System management software "MELSOFT Navigator" Programmable controller engineering software "MELSOFT GX Works3²(including GX Works2, PX Developer³)" Motion controller engineering software "MELSOFT MT Works2" HMI/GOT screen design software "MELSOFT GT Works3" Robot programming software "MELSOFT RT ToolBox3⁴" Inverter setup software "MELSOFT FR Configurator2" Servo amplifier setup software "MELSOFT MR Configurator2" C Controller module setting and monitoring tool "MELSOFT CW Configurator"
MELSOFT GX Works3 ²	<ul style="list-style-type: none"> Programmable controller engineering software (including GX Works2, PX Developer³)

*1: For details on the supported models of each software, refer to the manual for the product used.

*2: MELSOFT GX Works3 can be switched between Japanese, English, and Chinese (Simplified).

*3: The programming tool and monitoring tool for process control are included.

*4: RT ToolBox3 mini (simplified version) will be installed when iQ Works product ID is used. When RT ToolBox3 (with simulation function) is required, please purchase RT ToolBox3 product ID.

MELSOFT iQ Works

Product name	Model	Overview
MELSOFT iQ Works	SW2DND-IQWK-EC	Site license

MELSOFT GX Works3

Product name	Model	Overview
MELSOFT GX Works3	SW1DND-GXW3-EC	Site license

MELSOFT GX LogViewer

Product name	Model	Overview
MELSOFT GX LogViewer	SW1DNN-VIEWER-M	A tool for displaying and analyzing large-capacity data collected by the data logging function of the logger module and controller

CPU Module Logging Configuration Tool

Product name	Model	Overview
CPU Module Logging Configuration Tool	SW1DNN-LLUTL-M	A tool for configuring the logging settings of the controller in a wizard form

MELSOFT GX VideoViewer Future support ^{*1,2}

Product name	Model	Overview
MELSOFT GX VideoViewer	SW1DNN-REPROA-M	A tool for displaying and analyzing the saved videos using a camera recorder module

*1: The MX-F model is not supported.

*2: The cooperation of MX-R model will be supported in the future.

MELSOFT GX VideoViewer Pro Future support ^{*1,2}

Product name	Model	Overview
MELSOFT GX VideoViewer Pro	SW1DND-REPROAA-M	Standard license A tool with an AI analysis function based on Mitsubishi Electric's proprietary AI technology added to GX VideoViewer

*1: The MX-F model is not supported.

*2: The cooperation of MX-R model will be supported in the future.

MELSOFT Mirror Future support ^{*1}

Product name	Model	Overview
MELSOFT Mirror Perpetual license	SW1DND-LCS-MA1	Perpetual, 10 modules
	SW1DND-LCS-MA2	Perpetual, 20 modules
	SW1DND-LCS-MA5	Perpetual, 50 modules
	SW1DND-LCS-MZ	Perpetual, additional 10 modules
MELSOFT Mirror One year license	SW1DND-LCS-MA1Q12	Subscription, 10 modules
	SW1DND-LCS-MA2Q12	Subscription, 20 modules
	SW1DND-LCS-MA5Q12	Subscription, 50 modules
	SW1DND-LCS-MZQ12	Subscription, additional 10 modules

*1: The cooperation of MX-R model and MX-F model will be supported in the future.

MELSOFT Gemini Future support *1

Product name	Model	Overview
MELSOFT Gemini Essential Standalone	SW1DND-3DSIME-MQ12	Outright purchase, 1 year maintenance included
	SW1DND-3DSET-MQ06	Subscription (6 months)
	SW1DND-3DSET-MQ12	Subscription (12 months)
MELSOFT Gemini Essential Network	SW1DND-3DSEK-MQ12	Outright purchase, 1 year maintenance included
	SW1DND-3DSEKT-MQ06	Subscription (6 months)
	SW1DND-3DSEKT-MQ12	Subscription (12 months)
MELSOFT Gemini Professional Standalone	SW1DND-3DSIMR-MQ12	Outright purchase, 1 year maintenance included
	SW1DND-3DSRT-MQ06	Subscription (6 months)
	SW1DND-3DSRT-MQ12	Subscription (12 months)
MELSOFT Gemini Professional Network	SW1DND-3DSRK-MQ12	Outright purchase, 1 year maintenance included
	SW1DND-3DSRKT-MQ06	Subscription (6 months)
	SW1DND-3DSRKT-MQ12	Subscription (12 months)
MELSOFT Gemini Premium Standalone	SW1DND-3DSIMM-MQ12	Outright purchase, 1 year maintenance included
	SW1DND-3DSMT-MQ06	Subscription (6 months)
	SW1DND-3DSMT-MQ12	Subscription (12 months)
MELSOFT Gemini Premium Network	SW1DND-3DSMK-MQ12	Outright purchase, 1 year maintenance included
	SW1DND-3DSMKT-MQ06	Subscription (6 months)
	SW1DND-3DSMKT-MQ12	Subscription (12 months)

*1: The cooperation of MX-R model and MX-F model will be supported in the future.

GENESIS™ Future support *1

Product name	Model	Overview
GENESIS™ Plus Edition	GEN-PLUS	Basic license to develop/operate a system with GENESIS Plus edition
	GEN-PLUS-NAA	Notification/integration option license for GENESIS Plus edition
	GEN-PLUS-XTR	Additional node license for GENESIS Plus edition
	GEN-PLUS-ADV	Advanced option license for GENESIS Plus edition
	GEN-PLUS-ANA	Analysis option license for GENESIS Plus edition
	GEN-PLUS-INFR	Authentication/communication option license for GENESIS Plus edition
	GEN-PLUS-HE	Historical data access (data export) option license for GENESIS Plus edition
GENESIS™ Professional Edition	GEN-PLUS-HA(-□)	Historical data access (data export + WebAPI access) option license for GENESIS Plus edition The □ in the product model name indicates the number of WebAPI accesses (1500, 5000, 15000, 50000).
	GEN-PROF	Basic license to develop/operate a system with GENESIS Professional edition
	GEN-PROF-NAA	Notification/integration option license for GENESIS Professional edition
	GEN-PROF-XTR	Additional node license for GENESIS Professional edition
	GEN-PROF-ANA	Analysis option license for GENESIS Professional edition
	GEN-PROF-INFR	Authentication/communication option license for GENESIS Professional edition
GENESIS™ Prime Edition	GEN-PROF-HE	Historical data access (data export) option license for GENESIS Professional edition
	GEN-PROF-HA(-□)	Historical data access (data export + WebAPI access) option license for GENESIS Professional edition The □ in the product model name indicates the number of WebAPI accesses (1500, 5000, 15000, 50000).
	GEN-PRIM	Basic license to develop/operate a system with GENESIS Prime edition
	GEN-PRIM-XTR	Additional node license for GENESIS Prime edition
	GEN-PRIM-INFR	Authentication/communication option license for GENESIS Prime edition
GENESIS™ Platinum Edition	GEN-PRIM-HE	Historical data access (data export) option license for GENESIS Prime edition
	GEN-PRIM-HA(-□)	Historical data access (data export + WebAPI access) option license for GENESIS Prime edition The □ in the product model name indicates the number of WebAPI accesses (1500, 5000, 15000, 50000).
	GEN-PLAT	Basic license to develop/operate a system with GENESIS Platinum edition
	GEN-PLAT-XTR	Additional node license for GENESIS Platinum edition
GENESIS™ Platinum Edition	GEN-PLAT-HE	Historical data access (data export) option license for GENESIS Platinum edition
	GEN-PLAT-HA(-□)	Historical data access (data export + WebAPI access) option license for GENESIS Platinum edition The □ in the product model name indicates the number of WebAPI accesses (1500, 5000, 15000, 50000).

*1: The cooperation of MX-R model and MX-F model will be supported in the future.

BACnet is a trademark of ASHRAE.
CiA and CANopen are registered EU trademarks of CiA e.V.
EtherCAT® is a registered trademark and patented technology, licensed by Beckhoff Automation GmbH, Germany.
EtherNet/IP, DeviceNet, and CIP Safety are trademarks of ODVA, Inc.
AnalytiX is a registered trademark of Mitsubishi Electric Iconics Digital Solutions, Inc. and GENESIS64, GENESIS32, Hyper Historian, IoTWorX, KPIWorX, CFSWorX, MobileHMI, WebHMI, GENESIS, Hyper Historian, and Data Historian are trademarks of Mitsubishi Electric Iconics Digital Solutions, Inc.
MATLAB, Simulink, and PLC Coder are registered trademarks of The MathWorks, Inc.
Microsoft, Access, ActiveX, Azure, Bing, Microsoft Edge, Excel, HoloLens, Internet Explorer, SQL Server, Silverlight, Surface, Visual Basic, Visual C#, Visual C++, Visual Studio, Windows, Windows Phone, and Windows Server, Windows Vista are trademarks of the Microsoft group of companies.
OPC UA logo and OPC CERTIFIED logo are registered trademarks of OPC Foundation.
The name PLCopen® is a registered trademark owned by the association PLCopen.
QR Code is a trademark or a registered trademark of DENSO WAVE INCORPORATED in JAPAN, the United States and/or other countries.
All other company names and product names mentioned herein are trademarks or registered trademarks of their respective owners.
Trademark symbols such as "™" and "®" might be omitted in this document.

Precautions before use

This publication explains the typical features and functions of the products herein and does not provide restrictions or other information related to usage and module combinations. Before using the products, always read the product user manuals. Mitsubishi Electric will not be held liable for damage caused by factors found not to be the cause of Mitsubishi Electric; opportunity loss or lost profits caused by faults in Mitsubishi Electric products; damage, secondary damage, or accident compensation, whether foreseeable or not, caused by special factors; damage to products other than Mitsubishi Electric products; or any other duties.

For safe use

- To use the products given in this publication properly, always read the relevant manuals before beginning operation.
- The products have been manufactured as general-purpose parts for general industries, and are not designed or manufactured to be incorporated in a device or system used in purposes related to human life.
- Before using the products for special purposes such as nuclear power, electric power, aerospace, medicine or passenger-carrying vehicles, consult with Mitsubishi Electric.
- The products have been manufactured under strict quality control. However, when installing the products where major accidents or losses could occur if the products fail, install appropriate backup or fail-safe functions in the system.

Discover the latest information in Factory Automation

Factory Automation Global website

Mitsubishi Electric Factory Automation provides a mix of services to support its customers worldwide. A consolidated global website is the main portal, offering a selection of support tools and a window to its local Mitsubishi Electric sales and support network.

From here you can find:

- Overview of available factory automation products
- Library of downloadable literature
- Support tools such as online e-learning courses, terminology dictionary, etc.
- Global sales and service network portal
- Latest news related to Mitsubishi Electric factory automation

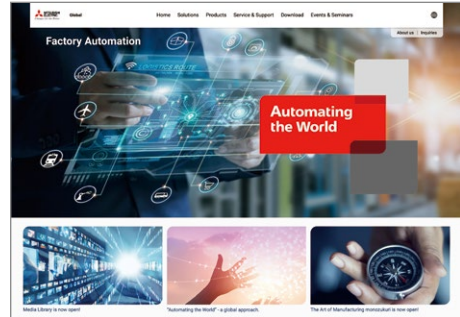

Mitsubishi Electric Factory Automation Global website:
www.MitsubishiElectric.com/fa

Mitsubishi Electric FA e-Learning

An extensive library of e-learning courses covering the factory automation product range.

Courses from beginner to advanced levels of difficulty are available anytime anywhere.



Beginner level

Designed for newcomers to Mitsubishi Electric Factory Automation products gaining a background of the fundamentals and an overview of various products related to the course.

Basic to Advanced levels

Various different features are explained along with setup, programming, and network configuration.

Innovative next-generation e-Manual

A next-generation digital manual that consolidates factory automation products manuals into an easy-to-use package with various useful features.

e-Manual Viewer

Multiple manuals can be cross-searched at once. Multiple users can share the latest manuals and knowhow with document sharing function.



e-Manual Create

Software for converting word files and chm files to e-Manual documents. User's customized machine manuals can be converted to e-Manual documents, allowing consolidated management of user's maintenance information and Mitsubishi Electric product information.

Find information on products, factory automation, e-F@ctory solutions and other topics

Follow us on Social Media

YouTube



Mitsubishi Electric FA Global

LinkedIn



Mitsubishi Electric FA Global

X



Mitsubishi Electric FA Global
@Mitsubishi_FA

Creating Solutions Together.



Industrial Computer



Controllers



Computerized Numerical Controllers



Drive Products



Human Machine Interfaces



Robots



Low-voltage Power Distribution Products



Medium-voltage Power Distribution Products



Energy Saving Supporting Devices

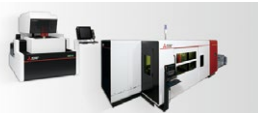

Processing Machines: EDM, Lasers



Engineering and Solution Software

Mitsubishi Electric's FA division provides robust support for our customers' manufacturing needs. We offer a vast array of FA products, including industry-leading PLCs, control devices, drive devices, energy efficiency support equipment, power distribution control equipment, and industrial mechatronics. Our presence on every type of production floor enables us to assist in labor-saving initiatives and quality improvements, helping customers achieve sustainable manufacturing. We also address challenges such as decarbonization and labor shortages through the utilization of automation technology.

Additionally, by leveraging synergies among FA technologies, manufacturing expertise, and digital innovations, we aim to streamline the construction of systems for data collection, accumulation, and analysis. This contributes to reducing manufacturing and quality losses.

We enable flexible manufacturing processes that respect legacy systems while embracing innovations to drive optimization. As your solution partner, Mitsubishi Electric FA delivers high-performance, high-quality products that enhance your competitiveness.

Let's automate the world together!

Sales office

MITSUBISHI ELECTRIC Factory Automation Global Website

► Locations Worldwide

www.MitsubishiElectric.com/fa/about-us/overseas/



e-F@ctory

Mitsubishi Electric's e-F@ctory concept utilizes both FA and IT technologies, to reduce the total cost of development, production and maintenance, with the aim of achieving manufacturing that is a "step ahead of the times". It is supported by the e-F@ctory Alliance Partners covering software, devices, and system integration, creating the optimal e-F@ctory architecture to meet the end users needs and investment plans.



**e-F@ctory
Alliance**

MITSUBISHI ELECTRIC CORPORATION
HEAD OFFICE: TOKYO BLDG., 2-7-3, MARUNOUCHI, CHIYODA-KU, TOKYO 100-8310, JAPAN