

FACTORY AUTOMATION

MITSUBISHI ELECTRIC INDUSTRIAL ROBOT MELFA RV-CR SERIES



Slim & Compact Robot Offering a High Level of Utility and Design

Maximum performance in minimum space

Slim & compact

A smooth, curved design complements the slim arm and compact joints. The external design is marked by minimalist, functional design.

High scalability

Supporting a wide variety of functions and options such as the tracking function, additional axis control, 2D vision sensor, force sensor, 3D vision sensor, MELFA Smart Plus, and network base card, MELFA RV-CR series are useful in various situations.

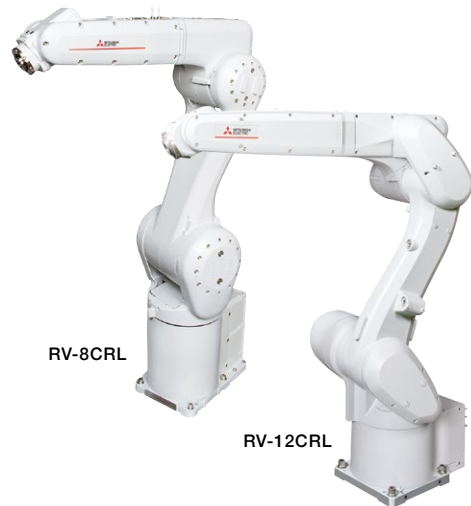

Lighter unit

Compared with RV-7/13FRL of the MELFA FR series, RV-8/12CRL reduced unit weight thanks to their simplified drive system and optimized arm structure, resulting in enhanced load capacity. MELFA RV-CR series robots are easy to integrate with automation cells and manufacturing equipment, and their slim structure makes them easy to handle.

Simple structure improves ease of maintenance

Beltless coaxial drive mechanism

A coaxial mechanism without belts is used for transmission to each axis (excluding the J4 and J5 axes for RV-8CRL, and the J5 axes for RV-12CRL).

Simplification of the structure has improved transmission efficiency and reliability. The ease of maintenance has also improved by reducing the number of points for periodic belt inspections.

No backup battery

The use of the new HK motor eliminates the need for a battery to back up the robot's internal encoder.

This eliminates the cost and effort of regular replacement as well as the risk of losing origin coordinate data due to battery failure.

Protrusionless structure suppresses interference with surroundings

In addition to a slim, compact exterior and small robot base, the structure of RV-8CRL features minimal protrusions to the front, back, and side, resulting in reduced interference with surroundings when the robot operates. This makes it suited to integration with automation cells and manufacturing equipment.

Large grippers for various situations

RV-12CRL has a large moment/inertia and an extensive number of inputs/outputs for gripper control, which makes the installation of large and complex grippers possible.

This enables the stable transfer of large workpieces using grippers that require a large number of cylinders and pads.

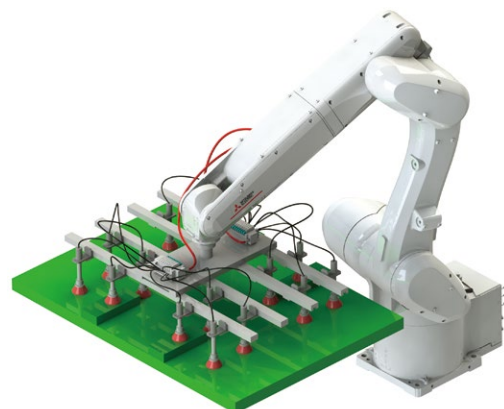
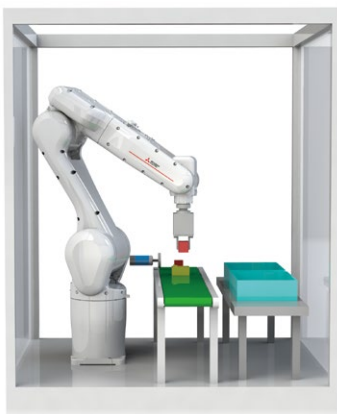

Wiring/piping built into arm

A signal wiring and air piping that can be used for gripper control, etc., are built in from the base to the forearm. For RV-8CRL, both ends of the signal wire have universal D-sub connectors for use in various application. RV-12CRL has two 15-pin connectors at both ends of the signal wires to handle a large number of signals. Connectors and air joints are on the side, making it easy to route the wiring.

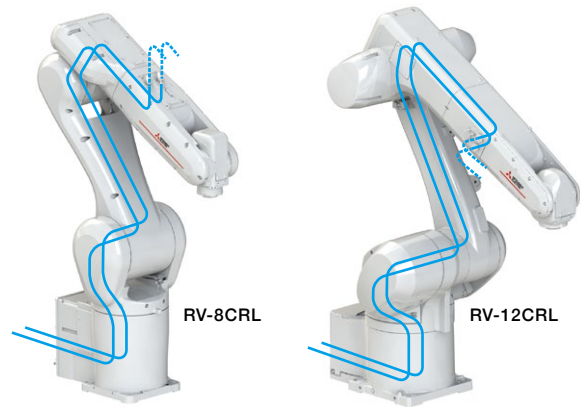

Built-in signal wiring and air piping for gripper control

Structure supporting external wiring/piping

RV-12CRL has a number of screw holes on the left side of the main unit to support easy wiring/piping. Internal wiring/piping is pulled out from the right side of the unit, allowing wiring without interference.

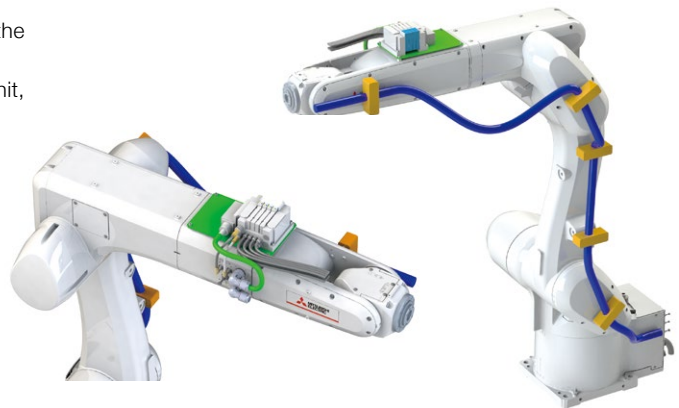

Equipped with a high-performance motor

Pursuing practical performance

Uses a battery-less motor that does not require periodic battery replacement. This allows improved torque characteristics, accuracy, and responsiveness while substantially reducing the size and weight. This adds up to much better robot performance and greater compactness.

Continuous operation performance

Lighter weight and improved heat release translate to improved continuous operation performance.

HK Series



High-speed wrist axis operation

RV-8/12CRL has the same wrist axis operation speed as the FR series. This leads to a particularly high performance when frequent wrist movements are required such as workpiece changeovers within processing machines.

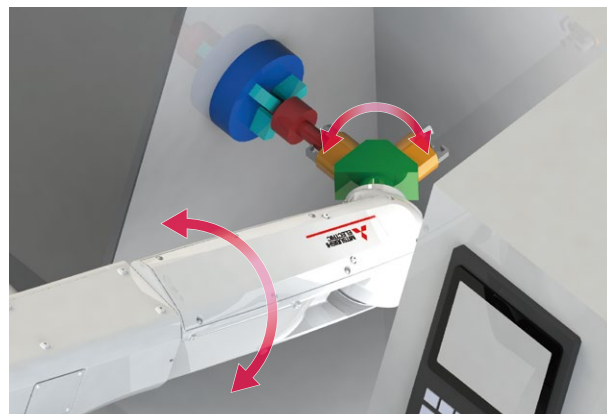

High-performance Controller Makes MELFA More Intelligent

Intelligent technology

Force sensor

- Checks pressing force and force conditions at time of insertion, improving operational quality
- Assembly of difficult-to-fit workpieces
- Teaching support via force information
- Improved force controllability via faster control cycle

Example use of intelligent technology

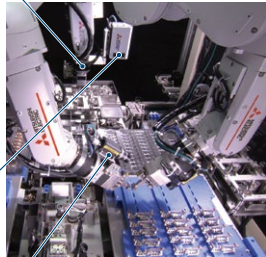

3D vision sensor

- Kitting and separation of scattered or stacked workpieces
- Simplification of installation via support functions

2D vision sensor

- Vision sensor configuration tool allows easy calibration of robot and camera
- Easy connection of robot and camera via Ethernet
- Easy control via robot program vision control command

Intelligent technology: MELFA Smart Plus*1

Advanced features such as integration functions for the various sensors and autonomous startup adjustment functions are provided for all phases of customer's operations, from design and startup through to operation and maintenance.

MELFA Smart Plus



Preventive maintenance function

Tracking the robot's operating status helps manage the condition of the robot.

Coordinated control of additional axis

Links robot and travel base for high-accuracy processing and assembly at specific speed.

Robot mechanism thermal compensation function

Compensates the thermal expansion of the robot arm to increase position accuracy.

Calibration assistance function

● Automatic calibration

Automatically adjusts the coordinates of the vision sensor to increase position accuracy.

● Workpiece coordinate calibration

Adjusts the robot and workpiece coordinates using a vision sensor to increase position accuracy.

● Relative position calibration

Automatically calibrates the positions of multiple robots using a vision sensor. Increases position accuracy in collaborative operation.

2D vision sensor enhancement function

Various vision applications are easily set up.

Force sensor enhancement function

Parameters for the optimum operation pattern are found using repeat learning in a short amount of time.

MELFA-3D Vision enhancement function

Reduced startup time thanks to automatic parameter adjustments.

*1: Not available for 12CRL.

8CRL is supported with robot controller CR800-D with software version A5p or later.

Safety functions

Safety monitoring function

A high level of safety that complies with international standards, allows for flexibility in building equipment.

Safety I/O

Extends redundant safety I/O to 8 inputs and 4 outputs. Enables development of various safety systems.

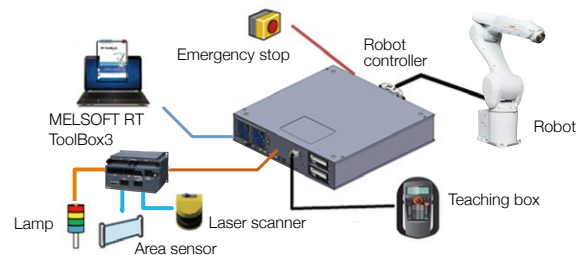

Safety logic editing

The operating conditions for the safety monitoring function can be easily defined from the setting screen.

Tracking and additional axis control

Comes standard with tracking and additional axis control

Tracking

Robot tracks workpiece on conveyor, allowing transfer, alignment, and assembly without stopping conveyor.

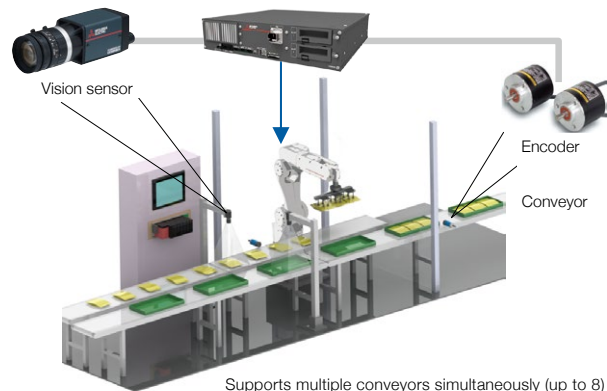

Supports multiple conveyors simultaneously (up to 8)

Additional axis control

Build user mechanism controlling additional axes simultaneously with robot such as robot drive axis or turntable or separate from robot such as loader or positioning device. Control up to 8 axes. Our MELSERVO (MR-J4-B) servomotor can be used with additional axes.

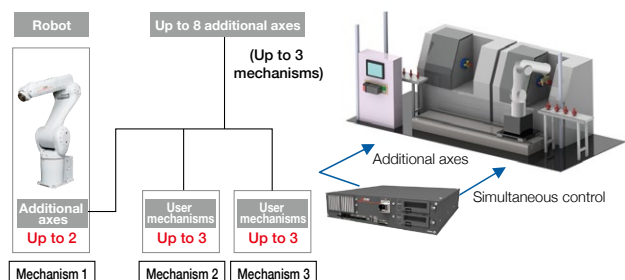

Software supporting program creation and total engineering: MELSOFT RT ToolBox3

PC software supporting everything from robot system design to installation, debugging, operation, and maintenance

- Program editing and debugging
- Simulation function
- 3D viewer
- Monitoring function
- Melfa RXM.ocx communication middleware

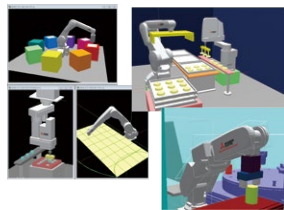
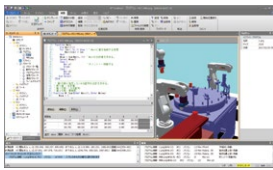

Visual programming

The visual programming function creates programs simply by connecting blocks corresponding to each command.

Visual programming enables intuitive operation, which makes it easy to start up robots even without knowledge of robotics.

Supporting major networks

Supports various networks for system expansion

Compatible with an optional network base card that supports four major networks, enabling system configuration using devices from various manufacturers and communication with higher-level devices.

Network	Base card model
CC-Link IE Field	2F-DQ535
EtherCAT	2F-DQ535-EC
EtherNet/IP	2D-TZ535
PROFINET	2D-TZ535-PN

Low-profile controller

Space-saving design

The CR800 controller is slim with a height of 99.5 mm and can be used in both vertical and horizontal positions. The controller can be placed in a variety of positions to fit into the available space of a device, contributing to space-saving.

Abundant inputs and outputs

Parallel I/O interface included as standard

RV-8/12CRL includes a parallel I/O interface card in the controller as standard. 32 inputs and 32 outputs can be externally inputted/outputted, which can be used for gripper control and peripheral equipment control.

Gripper cable options

For RV-12CRL, gripper cable options are available. This provides easier signal management of the gripper and controller, and reduces installation work-hours.

GOT integration

Directly linked with GOT

Enhanced efficiency of monitoring and maintenance operations onsite using a single GOT (display device) as the Human Machine Interface (HMI).

Example of GOT display

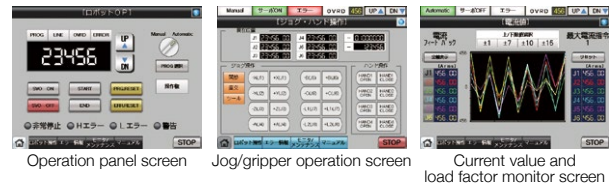

Enables the robot to be controlled from the GOT even without a teaching box.

Current robot position data, error information, etc. can be displayed easily on the GOT.

Internal robot information

- Error, variable, and program information
- Robot status (Current speed, current position, etc.)
- Maintenance information (Remaining battery capacity, grease life, etc.)
- Servo data (Load factor, current values, etc.)

Sample image files can be downloaded from the Mitsubishi Electric FA website.

- Useful sample image files that can immediately be used in actual systems.
- Sample sequence programs (function blocks) are provided for using the sample image files.

Note) The sample image files are for the GT27 (640 × 480 or better). To use the files, GT Designer3 version 1.178L or later is required.

Main Specifications

MELFA RV-8CRL

Vertical 8kg Type



RV-8CRL

Model

RV-8CRL-D (Controller is equipped with 2D-TZ368)
RV-8CRL-D-S15 (Controller is equipped with 2D-TZ378)

Specifications

Item	Unit	RV-8CRL
Environmental specifications		Oil mist
Protection specification		IP65*1
Installation posture		On floor, hanging, (against wall*2)
Structure		Vertical articulated robot
Degrees of freedom		6
Drive system		AC servo motor (brake provided on all axes)
Position detection method		Absolute encoder
Load capacity	Rating	kg
	Maximum	kg
Arm length	mm	450+470
Maximum reach radius (P point)	mm	931
Operating range	J1	Degree
	J2	Degree
	J3	Degree
	J4	Degree
	J5	Degree
	J6	Degree
Maximum speed	J1	Degree/s
	J2	Degree/s
	J3	Degree/s
	J4	Degree/s
	J5	Degree/s
	J6	Degree/s
Position repeatability	mm	±0.02
Ambient temperature	°C	0 to 40
Mass	kg	41
Tolerable moment	J4	Nm
	J5	Nm
	J6	Nm
Tolerable amount of inertia	J4	kgm ²
	J5	kgm ²
	J6	kgm ²
Tool wiring		15-pin D-sub
Tool pneumatic pipes		φ6×2
Machine cable	m	5
Connected controller		CR800-CVD

External dimensions/operating range

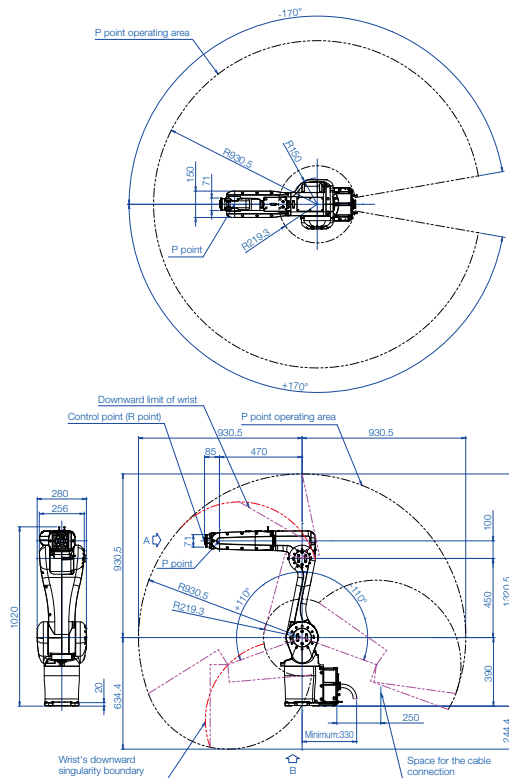

Mechanical interface

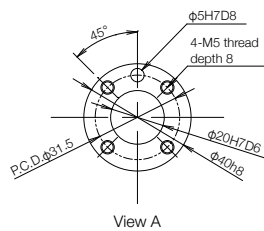

Internal wiring/piping

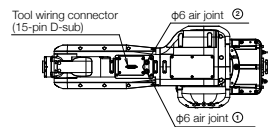

Installation dimensions

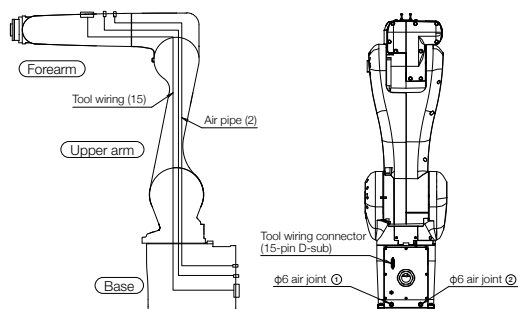
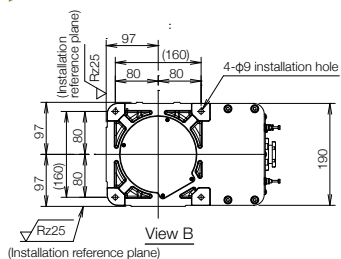

Wiring/piping

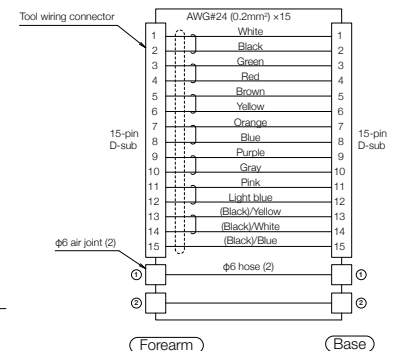

*1: Electrical devices and high-speed rotating parts susceptible to the effects of dust and water inside the arm are under the protection of IP65. Refer to the standard specifications manual for details.

*2: The wall mounting specifications are special specifications that restrict the operating range of the J1 axis.

*3: "Maximum load capacity" is the maximum weight that can be loaded under the limitation of a mechanical interface having a downward attitude (within ±10° of the vertical position).

MELFA RV-12CRL

Vertical 12kg Type

Model

RV-12CRL-D (Controller is equipped with 2D-TZ368)
RV-12CRL-D-S15 (Controller is equipped with 2D-TZ378)

Specifications

Item	Unit	RV-12CRL	
Environmental specifications		Oil mist	
Protection specification		IP65*1	
Installation posture		On floor, hanging	
Structure		Vertical articulated robot	
Degrees of freedom		6	
Drive system		AC servo motor (brake provided on all axes)	
Position detection method		Absolute encoder	
Load capacity	Rating	kg	12
	Maximum	kg	12
Arm length	mm	600+760	
Maximum reach radius (P point)	mm	1,504	
Operating range	J1	Degree	±170
	J2	Degree	-90 to +150
	J3	Degree	+0 to +170
	J4	Degree	±190
	J5	Degree	±120
	J6	Degree	±360
Maximum speed	J1	Degree/s	270
	J2	Degree/s	253
	J3	Degree/s	290
	J4	Degree/s	487
	J5	Degree/s	480
	J6	Degree/s	780
Position repeatability	mm	±0.04	
Ambient temperature	°C	0 to 40	
Mass	kg	110	
Tolerable moment	J4	Nm	26.5
	J5	Nm	26.5
	J6	Nm	11
Tolerable amount of inertia	J4	kgm ²	0.9
	J5	kgm ²	0.9
	J6	kgm ²	0.3
Tool wiring		15×2	
Tool pneumatic pipes		Φ6×2, Φ8×1	
Machine cable	m	5	
Connected controller		CR800-12CVD	



RV-12CRL

External dimensions/operating range

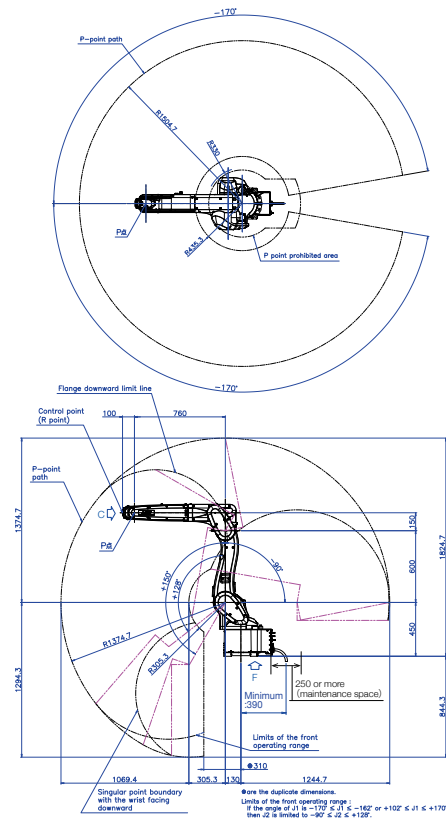

Mechanical interface

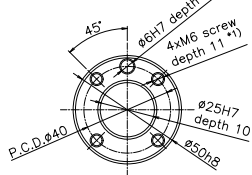

View C: Detail of mechanical interface

Internal wiring/piping

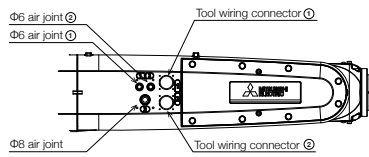

Installation dimensions

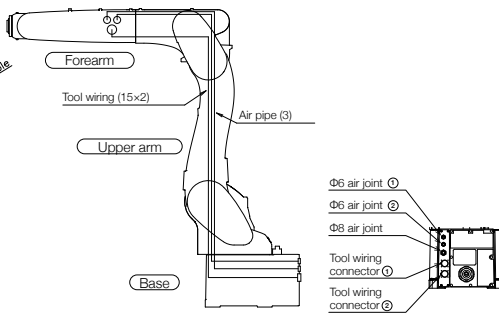
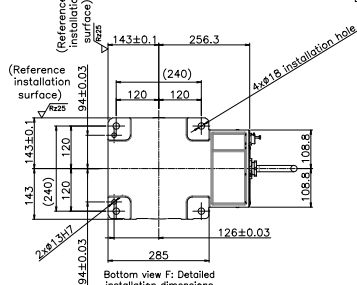

Wiring/piping

*The tool wiring connectors (JN1KW15PL1 (Japan Aviation Electronics Industry, Ltd.)) are all identical.

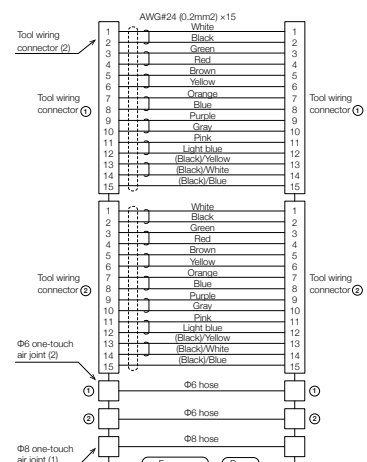

*1: Electrical devices and high-speed rotating parts susceptible to the effects of dust and water inside the arm are under the protection of IP65. Refer to the standard specifications manual for details.

Controller specifications

MELFA Controller CR800-CVD CR800-12CVD

Stand-alone robot controller
Robot controller can be used for centralized control.



CR800-CVD
CR800-12CVD

External dimensions

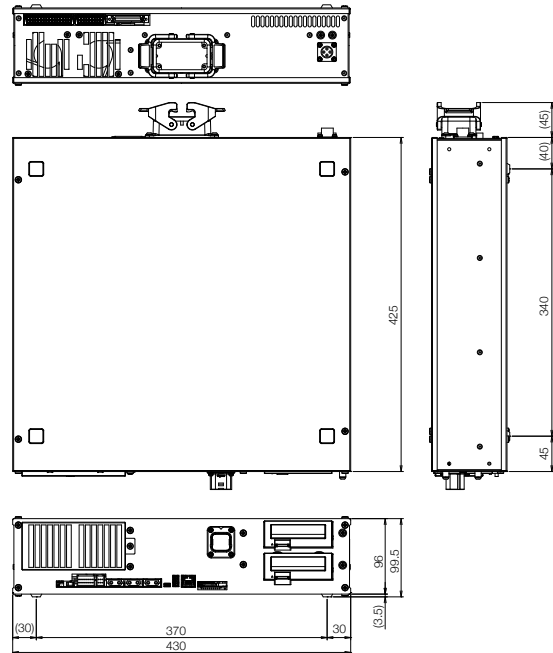

Specifications

Item		Unit	CR800-CVD	CR800-12CVD
Number of axes controlled			Up to 6+8 additional axes	
Robot language			MELFA-BASIC V, VI	
Position teaching method			Teaching, MDI	
Memory capacity	Number of teaching points	point	39000	
	Number of steps	step	78000	
	Number of programs	unit	512	
External input/output	General-purpose I/O	point	32 inputs/32 outputs 2D-TZ368 (sink type) is attached at the time of shipment. The 2D-TZ378 (source type) is installed from the factory in the S15 with special specifications	
	Dedicated I/O	point	Assigned to general-purpose I/O	
	Emergency stop input	point	1 (Redundant)	
	Door switch input	point	1 (Redundant)	
	Mode selector switch input *6	point	1 (Redundant)	
	Emergency stop output	point	1 (Redundant)	
	Mode output	point	1 (Redundant)	
	Robot error output	point	1 (Redundant)	
Interface	Synchronization of additional axes	point	1 (Redundant)	
	Encoder input	channel	2	
	Additional axis, force sensor interface	channel	1(SSCNET III/H)	
	Remote I/O	channel	1(Compatible with Ver. 1.0/2.0)	
	USB	port	1(Ver. 2.0 High Speed device functions only. USB mini-B)	
	Ethernet	port	1(For user: 1000BASE-T/ 100BASE-TX/10BASE-T) 1(For T/B: 100BASE-TX/ 10BASE-T)	
	Extension slot	slot	2 For option interface 2D-TZ368 is installed to slot 1. The 2D-TZ378 is installed in the S15 with special specification.	
SD memory card slot	slot	1(For extended memory)		
RS-422	port	1(Dedicated T/B)		
Ambient temperature	°C	0 to 40		
Ambient humidity	%RH	45 to 85		
Power supply	Input voltage range *2	V	Single phase 200 AC to 230 AC	Single phase 230 AC, 3-phase 200 AC to 230 AC
	Power capacity *3	kVA	2.0	3.0
External dimensions	mm	430 (W)×425 (D)×99.5 (H)		
Mass	kg	Approx. 12.5		
Structure		Self-contained/open structure (can be placed vertically or horizontally) [IP20]		
Grounding *4	Ω	100 or less (Class D grounding)		

*1: For installing optional interface

*2: Power supply voltage variability is within 10%.

*3: The power capacity is the recommended value.

The power capacity does not include the rush current when the power is turned ON. The power capacity is a guideline.

*4: Grounding work is to be performed by the customer.

*5: Recommended USB cable (USB A-to-USB mini B): MR-J3USBCBL3M (Mitsubishi Electric), GT09-C30USB-5P (Mitsubishi Electric System & Service)

*6: Mode selector switch is to be provided by the customer.

System configuration

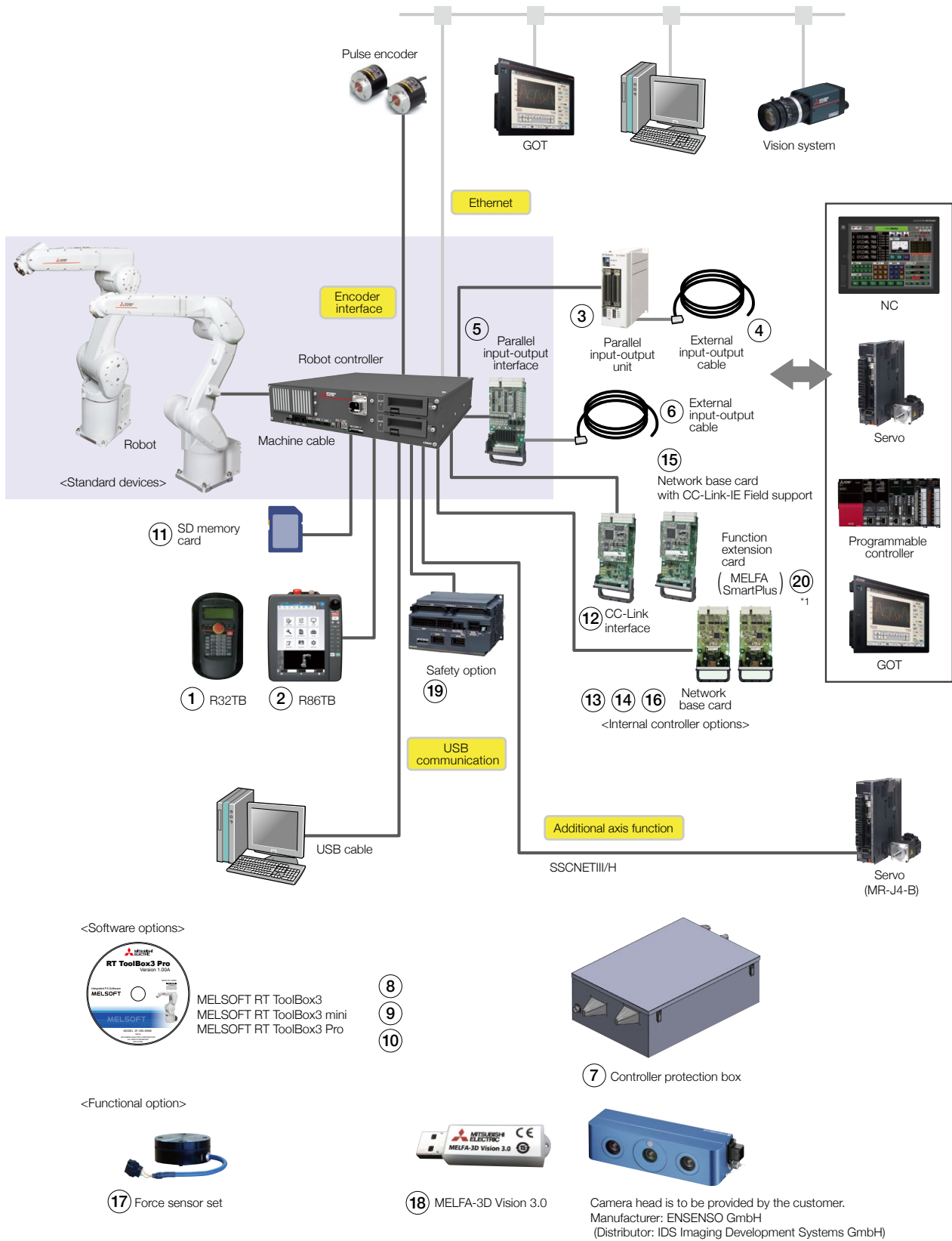

*1: RV-8CRL is supported with robot controller CR800-D with software version A5p or later.

Options

Mechanical options

Name	Model	RV-8CRL	RV-12CRL	Specifications
Hand input-output cable	1F-HC1000S-43	-	•	15 inputs/15 outputs
Machine cable (replacement) (Fixed)	1F-□□UCBL-43	•	•	Replacement type: 10 m, 15 m, 20 m. □□ is cable length (10 m, 15 m, or 20 m).
Machine cable (replacement) (Bending)	1F-□□LUCBL-43	•	•	Replacement type: 10 m, 15 m, 20 m. □□ is cable length (10 m, 15 m, or 20 m).
J1 axis operating range change	1F-DH-42J1	-	•	Stopper for changing the operating range is to be replaced by the customer.

Controller options

Number	Name	Model	Specifications
①	Simple teaching box (7 m, 15 m)	R32TB (-□□)	7 m: Standard 15 m: Special (-15 is added to model)
②	High performance teaching box (7 m)	R86TB	7 m: Standard. For a length longer than 7 m, use a teaching box extension cable.
③	Parallel input-output unit	(Sink type) 2A-RZ361	32 inputs/32 outputs *Cannot be used with safety option
		(Source type) 2A-RZ371	
④	External input-output cable (5 m, 15 m)	2A-CBL□□	CBL05: 5 m CBL15: 15 m one end unterminated. For 2A-RZ361/371
⑤	Parallel input-output interface	(Sink type) 2D-TZ368	32 inputs/32 outputs *Slot 1 standard-equipped with sink type. Models equipped with source type are also available.
		(Source type) 2D-TZ378	
⑥	External input-output cable (5 m, 15 m)	2D-CBL□□	CBL05: 5 m CBL15: 15 m one end unterminated. For 2D-TZ368/378
⑦	Controller protection box	CR800-MB	Built-in controller. Protects against dust and water. (IP54)
⑧	MELSOFT RT ToolBox3	3F-14C-WINJ	With simulation function (DVD-ROM)
⑨	MELSOFT RT ToolBox3 mini	3F-15C-WINJ	Simple (DVD-ROM)
⑩	MELSOFT RT ToolBox3 Pro	3F-16D-WINJ	Professional (DVD-ROM)
⑪	SD memory card	2F-2GBSD	2GB logging
⑫	CC-Link interface	2D-TZ576	CC-Link intelligent device station Ver.2.0 support, 1-4 stations
⑬	Network base card (Ethernet/IP interface)	2D-TZ535	Communication interface for HMS Anybus-CompactCom module. HMS EtherNet/IP module (AB6314-B-218) is to be provided by the customer.
⑭	Network base card (PROFINET interface)	2D-TZ535-PN	Communication interface for HMS Anybus-CompactCom module. HMS PROFINET module (AB6489-B) is to be provided by the customer.
⑮	Network base card (CC-Link-IE Field interface)	2F-DQ535	Communication interface for HMS Anybus-CompactCom module. HMS CC-Link IE Field module (AB6709-B-116) is to be provided by the customer.
⑯	Network base card (EtherCAT interface)	2F-DQ535-EC	Communication interface for HMS Anybus-CompactCom module. HMS EtherCAT module (AB6707-D-224) is to be provided by the customer.

Functional options

Number	Name	Model	Specifications
⑰	Force sensor set	4F-FS002H-W200	Set of equipment required for force control function, including force sensor, interface unit, and support software
		4F-FS002H-W1000	
⑱	MELFA-3D Vision 3.0	3F-53U-WINM	MELFA-3D Vision software
⑲	Safety option	4F-SF002-01	Equipment necessary for safety function

Expanded software functions

Number	Name	Model	RV-8CRL	RV-12CRL	Specifications
⑳	MELFA Smart Plus card pack*1	2F-DQ510	•	-	Enables all Type A functions
		2F-DQ520	•	-	Enables all Type A and B functions
	MELFA Smart Plus card*1	2F-DQ511	•	-	Enables one Type A function of your choice
		2F-DQ521	•	-	Enables one Type B function of your choice

Classification	Name	Model	Specifications
Intelligent functions	Calibration assistance function	A	Supports calibration of position with other equipment using 2D vision sensor
	Automatic calibration		Automatically corrects vision sensor coordinates to improve positional accuracy
	Work coordinate calibration		Corrects robot and workpiece coordinates using vision sensor to improve positional accuracy
	Relative position calibration		Corrects position between multiple robots using vision sensor. Improves positional accuracy of coordinated actions
	2D vision sensor enhancement function	A	A vision application can be set up easily by following the instructions on the setting screens even when robot programs that require specialist knowledge have not been created.
	Robot mechanism thermal compensation function	A	Compensates for thermal expansion of robot arm to improve positional accuracy
	Coordinate control of additional axes	A	Performs high-accuracy coordinated (interpolation) work with additional axes (direct coaxial)
	Preventive maintenance function (Maintenance simulation, wear calculation function)	A	Manages robot condition by tracking operational status
AI functions	MELFA-3D Vision enhancement function	B	Utilizes AI technology to automate 3D vision sensor adjustments and improve measurement and recognition performance
	Predictive maintenance function (Fault detection function)	B	Detects failing drive parts before abnormalities in robot behavior become apparent. *By enabling this function, the predictive maintenance function (maintenance simulation and wear calculation function) can also be used.
	Enhancement function for force sense control	B	Utilizes AI technology for repeated learning in short time periods and to calculate optimal insertion patterns

*1: RV-8CRL is supported with robot controller CR800-D with software version A5p or later.

Creating Solutions Together.



Low-voltage Power Distribution Products



Transformers, Med-voltage Distribution Products



Power Monitoring and Energy Saving Products



Power (UPS) and Environmental Products



Compact and Modular Controllers



Servos, Motors and Inverters



Visualization: HMIs



Edge Computing Products



Numerical Control (NC)



Collaborative and Industrial Robots



Processing machines: EDM, Lasers



SCADA, analytics and simulation software

Mitsubishi Electric's product lineup, from various controllers and drives to energy-saving devices and processing machines, all help you to automate your world. They are underpinned by software, innovative data monitoring, and modelling systems supported by advanced industrial networking and Edgecross IT/OT connectivity. Together with a worldwide partner ecosystem, Mitsubishi Electric factory automation (FA) has everything to make IoT and Digital Manufacturing a reality.

With a complete portfolio and comprehensive capabilities that combine synergies with diverse business units, Mitsubishi Electric provides a one-stop approach to how companies can tackle the shift to clean energy and energy conservation, carbon neutrality and sustainability, which are now a universal requirement of factories, buildings, and social infrastructure.

We at Mitsubishi Electric FA are your solution partners waiting to work with you as you take a step toward the realization of sustainable manufacturing and society through the application of automation. Let's automate the world together!

Global Partner. Local Friend.

USA Mitsubishi Electric Automation, Inc. 500 Corporate Woods Parkway, Vernon Hills, IL 60061, U.S.A. TEL: +1-847-478-2100	Brazil Mitsubishi Electric do Brazil Comercio e Servicos Ltda. Avenida Adelino Cardana, 293, 21.o andar, Bethaville, Barueri SP, Brazil 06401-147 TEL: +55 (11) 4689-3003	Mexico Mitsubishi Electric Automation, Inc. Mexico Branch Boulevard Miguel de Cervantes Saavedra 301, Torre Norte Piso 5 Col. Ampliacion Granada, Miguel Hidalgo, Ciudad de Mexico, C.P.11520, Mexico TEL: +52(55)3067-7500
Australia Mitsubishi Electric Australia Pty. Ltd 348 Victoria Road, Rydalmere, NSW, 2116 Australia TEL: +61-2-9684-7777	China Mitsubishi Electric Automation (China) Ltd. No.1386 Hongqiao Road, Mitsubishi Electric Automation Center 3FShanghai, China TEL: +86-21-2322-3030	Taiwan Mitsubishi Electric Taiwan Co., Ltd. 10F, No.88 Sec. 6, Chung-Shan N.Rd,Taipei, Taiwan, TEL: +886-02-2833-5430
Korea Mitsubishi Electric Automation Korea Co.,Ltd 7F-9F, Gangseo Hangang Xi-lower A, 401, Yangcheon-ro, Gangseo-Gu, Seoul 157-801, Korea TEL: +82-2-3664-8333	Singapore Mitsubishi Electric Asia Pte. Ltd 307 Alexandra Road, Mitsubishi Electric Building, Singapore 159943 TEL: +65-6473-2486	Malaysia MITSUBISHI ELECTRIC SALES MALAYSIA SDN. BHD. Lot 11, Jalan 51A/219, Seksyen 51A, 46100 Petaling Jaya, Selangor Darul Ehsan, Malaysia +60-3-7626-5000
Indonesia PT. Mitsubishi Electric Indonesia Gedung Jaya 8th Floor, J.L. MH. Thamrin No.12, Jakarta Pusat 10340, Indonesia TEL: +62-21-3192-6461	Vietnam Mitsubishi Electric Vietnam Company Limited 11th & 12th Floor, Viettel Tower B, 285 Cach Mang Thang Tam Street, Ward 12, District 10, Ho Chi Minh City, Vietnam. TEL: +84-28-3910-5945	Thailand Mitsubishi Electric Factory Automation (Thailand) Co., Ltd. 101, True Digital Park Office, 5th Floor, Sukhumvit Road, Bang Chak, Prakanong, Bangkok, Thailand TEL: +66-2092-8600
Philippines MELCO Factory Automation Philippines Inc. 128, Lopez-Rizal St. Brgy, Highway Hills, Mandaluyong City, MM, Philippines TEL: +63-(0)2-8256-8042	India Mitsubishi Electric India Pvt. Ltd. ICC-Devi Gaurav Technology Park, Unit no.402, Fourth Floor, Survey no. 191-192 (P) ,Opp, Vallabh Nagar Bus Depot, Pune - 411018, Maharashtra, India TEL:+91-(20)-46242100	Germany Mitsubishi Electric Europe B.V. German Branch Mitsubishi-Electric-Platz 1, 40882 Ratingen, Germany TEL: +49-2102-486-0
UK Mitsubishi Electric Europe B.V. UK Branch Travellers Lane, Hatfield, Hertfordshire, AL10 8XB, U.K TEL: +44 (0) 1707/28-87-80	Italy Mitsubishi Electric Europe B.V. Italian Branch Energy Park Via Energy Park 14, 20871, Vimercate (MB) TEL: +39-039-60531	Spain Mitsubishi Electric Europe, B.V. Spanish Branch Carretera de Rubi, 76-80-AC, 4720, E-08190 Sant Cugat del Valles (Barcelona), Spain TEL: +34-935-65-3131
France Mitsubishi Electric Europe B.V. French Branch 2, Rue de l'Union-92565 Rueil-Malmaison Cedex TEL: +33 (0) 1-55-68-57-01,	Czech Republic Mitsubishi Electric Europe B.V. Czech Branch, Prague Office Pekarska 621/7, 155 00 Praha 5, Czech Republic TEL: +420-734-402-587	Poland Mitsubishi Electric Europe B.V. Polish Branch ul. Krakowska 50, 32-083 Balice, Poland TEL: +48(0)12-347-65-00
Ireland Mitsubishi Electric Europe B.V. Irish Branch Westgate Business Park, Ballymount, IRL-Dublin 24 TEL: +353-14198800	Netherland Mitsubishi Electric Europe B.V. Netherlands Branch Capronilaan 46, NL-1119 NS Schiphol-Rijk TEL: +31-297-250-350	Hungary Mitsubishi Electric Europe B.V. Hungarian Branch 2040 Budaors, Szabadsag ut 117 TEL: +36-70-3322-372
Sweden Mitsubishi Electric Europe B.V. Sweden Branch Hedvig Mollers gata 6 223 55 Lund TEL: +46(0)8-625-10-84	Turkey Mitsubishi Electric Europe B.V. Turkey Branch Serifali Mahallesi. Kale Sok. No.41, 34775 Umraniye / ISTANBUL TEL: +90(0)216/969-25-00	India MITSUBISHI ELECTRIC INDIA PRIVATE LIMITED ICC Devi Gaurav Technology park, Unit no 4+B12:D2902 4th floor, Pimpri Pune -411018 Maharashtra India TEL: +91-020-46242227

Windows is registered trademark of Microsoft Corporation in the United States and other countries.
 Ethernet is registered trademark of Xerox Corporation.
 SolidWorks is trademark of Dassault Systèmes SolidWorks Corporation.
 All other company names and product names used in this document are trademarks or registered trademarks of their respective companies.



Mitsubishi Electric's e-F@ctory concept utilizes both FA and IT technologies, to reduce the total cost of development, production and maintenance, with the aim of achieving manufacturing that is a "step ahead of the times". It is supported by the e-F@ctory Alliance Partners covering software, devices, and system integration, creating the optimal e-F@ctory architecture to meet the end users needs and investment plans.



MITSUBISHI ELECTRIC CORPORATION

HEAD OFFICE: TOKYO BLDG., 2-7-3 MARUNOUCHI, CHIYODA-KU, TOKYO 100-8310, JAPAN