

Mitsubishi Electric Industrial Robot

CR800 series controller

ADDITIONAL AXIS FUNCTION INSTRUCTION MANUAL

Safety Precautions

Always read the following precautions and the separate "Safety Manual" before starting use of the robot to learn the required measures to be taken.

 **CAUTION** All teaching work must be carried out by an operator who has received special training.
(This also applies to maintenance work with the power source turned ON.)
→Enforcement of safety training

 **CAUTION** For teaching work, prepare a work plan related to the methods and procedures of operating the robot, and to the measures to be taken when an error occurs or when restarting. Carry out work following this plan.
(This also applies to maintenance work with the power source turned ON.)
→Preparation of work plan

 **WARNING** Prepare a device that allows operation to be stopped immediately during teaching work.
(This also applies to maintenance work with the power source turned ON.)
→Setting of emergency stop switch

 **CAUTION** During teaching work, place a sign indicating that teaching work is in progress on the start switch, etc.
(This also applies to maintenance work with the power source turned ON.)
→Indication of teaching work in progress

 **DANGER** Provide a fence or enclosure during operation to prevent contact of the operator and robot.
→Installation of safety fence

 **CAUTION** Establish a set signaling method to the related operators for starting work, and follow this method.
→Signaling of operation start

 **CAUTION** As a principle turn the power OFF during maintenance work. Place a sign indicating that maintenance work is in progress on the start switch, etc.
→Indication of maintenance work in progress

 **CAUTION** Before starting work, inspect the robot, emergency stop switch and other related devices, etc., and confirm that there are no errors.
→Inspection before starting work

The points of the precautions given in the separate "Safety Manual" are given below. Refer to the actual "Safety Manual" for details.



DANGER

When automatic operation of the robot is performed using multiple control devices (GOT, programmable controller, push-button switch), the interlocking of operation rights of the devices, etc. must be designed by the customer.



CAUTION

Use the robot within the environment given in the specifications. Failure to do so could lead to faults or a drop of reliability. (Temperature, humidity, atmosphere, noise environment, etc.)



CAUTION

Transport the robot with the designated transportation posture. Transporting the robot in a non-designated posture could lead to personal injuries or faults from dropping.



CAUTION

Always use the robot installed on a secure table. Use in an instable posture could lead to positional deviation and vibration.



CAUTION

Wire the cable as far away from noise sources as possible. If placed near a noise source, positional deviation or malfunction could occur.



CAUTION

Do not apply excessive force on the connector or excessively bend the cable. Failure to observe this could lead to contact defects or wire breakage.



CAUTION

Make sure that the workpiece weight, including the hand, does not exceed the rated load or tolerable torque. Exceeding these values could lead to errors or faults.



WARNING

Securely install the hand and tool, and securely grasp the workpiece. Failure to observe this could lead to personal injuries or damage if the object comes off or flies off during operation.



WARNING

Securely ground the robot and controller. Failure to observe this could lead to malfunctioning by noise or to electric shock accidents.



CAUTION

Indicate the operation state during robot operation. Failure to indicate the state could lead to operators approaching the robot or to incorrect operation.



WARNING

When carrying out teaching work in the robot's movement range, always secure the priority right for the robot control. Failure to observe this could lead to personal injuries or damage if the robot is started with external commands.





CAUTION

Keep the jog speed as low as possible, and always watch the robot. Failure to do so could lead to interference with the workpiece or peripheral devices.

 **CAUTION** After editing the program, always confirm the operation with step operation before starting automatic operation. Failure to do so could lead to interference with peripheral devices because of programming mistakes, etc.

 **CAUTION** Make sure that if the safety fence entrance door is opened during automatic operation, the door is locked or that the robot will automatically stop. Failure to do so could lead to personal injuries.

 **CAUTION** Never carry out modifications based on personal judgments, non-designated maintenance parts. Failure to observe this could lead to faults or failures.

 **WARNING** When the robot arm has to be moved by hand from an external area, do not place hands or fingers in the openings. Failure to observe this could lead to hands or fingers catching depending on the posture.

 **CAUTION** Do not stop the robot or apply emergency stop by turning the robot controller's main power OFF. If the robot controller main power is turned OFF during automatic operation, the robot accuracy could be adversely affected. Also a dropped or coasted robot arm could collide with peripheral devices.

 **CAUTION** Do not turn OFF the robot controller's main power while rewriting the robot controller's internal information, such as a program and parameter. Turning OFF the robot controller's main power during automatic operation or program/parameter writing could break the internal information of the robot controller.

 **DANGER** Do not connect the Handy GOT when using the GOT direct connection function of this product. Failure to observe this may result in property damage or bodily injury because the Handy GOT can automatically operate the robot regardless of whether the operation rights are enabled or not.

 **DANGER** Do not connect the Handy GOT to a programmable controller when using an iQ Platform compatible product with the CR800-R/CR800-Q series. Failure to observe this may result in property damage or bodily injury because the Handy GOT can automatically operate the robot regardless of whether the operation rights are enabled or not.

 **DANGER** Do not remove the SSCNET III cable while power is supplied to the multiple CPU system or the servo amplifier when using an iQ Platform compatible product with the CR800-R/CR800-Q series. Do not look directly at light emitted from the tip of SSCNET III connectors or SSCNET III cables of the Motion CPU or the servo amplifier. Eye discomfort may be felt if exposed to the light.
(Reference: SSCNET III employs a Class 1 or equivalent light source as specified in JIS C 6802 and IEC60825-1 (domestic standards in Japan).)

 **DANGER** Do not remove the SSCNET III cable while power is supplied to the controller. Do not look directly at light emitted from the tip of SSCNET III connectors or SSCNET III cables. Eye discomfort may be felt if exposed to the light.
(Reference: SSCNET III employs a Class 1 or equivalent light source as specified in JIS C 6802 and IEC60825-1 (domestic standards in Japan).)

**DANGER**

Attach the cap to the SSCNET III connector after disconnecting the SSCNET III cable. If the cap is not attached, dirt or dust may adhere to the connector pins, resulting in deterioration connector properties, and leading to malfunction.

**CAUTION**

Make sure there are no mistakes in the wiring. Connecting differently to the way specified in the manual can result in errors, such as the emergency stop not being released. In order to prevent errors occurring, please be sure to check that all functions (such as the teaching box emergency stop, customer emergency stop, and door switch) are working properly after the wiring setup is completed.

**CAUTION**

Use the network equipments (personal computer, USB hub, LAN hub, etc) confirmed by manufacturer. The thing unsuitable for the FA environment (related with conformity, temperature or noise) exists in the equipments connected to USB. When using network equipment, measures against the noise, such as measures against EMI and the addition of the ferrite core, may be necessary. Please fully confirm the operation by customer. Guarantee and maintenance of the equipment on the market (usual office automation equipment) cannot be performed.

**CAUTION**

To maintain the security (confidentiality, integrity, and availability) of the robot and the system against unauthorized access, DoS^{*1} attacks, computer viruses, and other cyberattacks from unreliable networks and devices via network, take appropriate measures such as firewalls, virtual private networks (VPNs), and antivirus solutions. Mitsubishi Electric shall have no responsibility or liability for any problems involving robot trouble and system trouble by unauthorized access, DoS attacks, computer viruses, and other cyberattacks.

*1 DoS: A denial-of-service (DoS) attack disrupts services by overloading systems or exploiting vulnerabilities, resulting in a denial-of-service (DoS) state.

■ History

| Print date | Instruction manual No. | Revision content |
|------------|------------------------|---------------------------------------------------------------------------------------------------------------------------------------------------------------------------------------------|
| 2017-05-23 | BFP-A3504 | <ul style="list-style-type: none"> • First print. |
| 2018-02-01 | BFP-A3504-A | <ul style="list-style-type: none"> • The CR800-Q controller was added. |
| 2020-10-30 | BFP-A3504-B | <ul style="list-style-type: none"> • Amended the precautions regarding the prevention of unauthorized access. • Corrected other mistakes and changed some sections. |
| 2021-09-30 | BFP-A3504-C | <ul style="list-style-type: none"> • Added the following parameters: MnSRVON, MnSRVOFF • Corrected other mistakes and changed some sections. |
| 2023-09-14 | BFP-A3504-D | <ul style="list-style-type: none"> • Added the CR860 controller. |
| | | |

■ Preface

Thank you for purchasing Mitsubishi Electric Industrial Robot.

The additional axis interface is a general-purpose servo amplifier control interface in combination with CR800 series controller.

Before use, be sure to read this manual for sufficient understanding. Then use the additional axis interface.

In this manual, the CR800 series indicates the CR800 and CR860 controllers.

The CR800 controller indicates the CR800-D, CR800-Q, or CR800-R controller.

The CR860 controller indicates the CR860-D, CR860-Q, or CR860-R controller.

- No part of this manual may be reproduced by any means or in any form, without prior consent from Mitsubishi.
- The details of this manual are subject to change without notice.
An effort has been made to make full descriptions in this manual. However, if any discrepancies or unclear points are found, please contact your dealer.
- The information contained in this document has been written to be accurate as much as possible. Please interpret that items not described in this document "cannot be performed" or "error may occur".
Please contact your nearest dealer if you find any doubtful, wrong or skipped point.
- This is the original document.
- All company names and production names in this document are the trademarks or registered trademarks of their respective owners.

Contents

| | |
|------------------------------------------------------------------------------------------------------------------|----|
| 1. How to use the instruction manual..... | 1 |
| 1.1 Content of instruction manual..... | 1 |
| 1.2 Codes of instruction manual..... | 1 |
| 1.3 Terms used in instruction manual | 2 |
| 2. Flow of works | 3 |
| 2.1 Flow of works | 3 |
| 3. Additional axis function | 4 |
| 3.1 What is the additional axis function? | 4 |
| 3.2 System configuration example of additional axis function..... | 5 |
| 3.3 Additional axis interface functions | 7 |
| 3.4 Additional axis function specifications | 7 |
| 4. Confirmation of product..... | 9 |
| 4.1 Necessary products..... | 9 |
| 5. Connection and Wiring..... | 10 |
| 5.1 Connection of Robot CPU and servo amplifier..... | 10 |
| 5.2 Synchronize the power supply of the robot controller | 12 |
| 5.2.1 Conceptual diagram of an additional axis system (CR800 controller)..... | 12 |
| 5.2.2 The power supply synchronization, the main circuit power supply control for addition axes.(Example). | 13 |
| 5.3 Installation of noise filter to power cable | 17 |
| 5.3.1 EMC filter (recommended) | 17 |
| 5.3.2 Line noise filters | 19 |
| 5.4 Connection example of servo amplifier and servo motor | 20 |
| 5.5 Installing the Servo System..... | 20 |
| 6. Servo system setting..... | 21 |
| 6.1 Servo amplifier setting..... | 21 |
| 6.2 Parameter setting of servo amplifier..... | 21 |
| 7. Setting, Operation and Command Explanation of Robot Additional Axis..... | 22 |
| 7.1 Description of parameters | 22 |
| 7.1.1 Parameter list..... | 23 |
| 7.1.2 Details of parameters | 24 |
| 7.1.3 About using the linear servo motor | 30 |
| 7.2 Confirmation of connection..... | 32 |
| 7.3 Try to use the robot additional axis | 33 |
| 7.3.1 Turn ON the power supply | 33 |
| 7.3.2 Move the robot additional axis | 33 |
| 7.3.3 Set the origin | 34 |
| 7.3.4 Create a program | 35 |

| | |
|--------------------------------------------------------------------------|----|
| 7.3.5 Execute a program | 35 |
| 7.3.6 End the operation | 35 |
| 7.4 Operation of the Robot's Additional Axis | 36 |
| 7.4.1 Brake release | 36 |
| 7.4.2 Origin setting | 36 |
| 7.4.3 Servo ON/OFF | 36 |
| 7.4.4 Jog operation | 37 |
| 7.4.5 Operation of position variable | 38 |
| 7.4.6 MDI (Manual Data Input) compensation of robot additional axis..... | 39 |
| 7.4.7 Operation | 39 |
| 7.4.8 Stop..... | 40 |
| 7.4.9 Error resetting | 41 |
| 7.5 Explanation of commands | 42 |
| 7.5.1 Interpolation commands..... | 42 |
| 7.5.2 Synchronous control of robot additional axis (travel axis)..... | 43 |
| 7.5.3 Position variables | 46 |
| 7.6 Example of System Configuration of the Robot's Additional Axis | 47 |
| 7.6.1 Travel axis system | 47 |
| 8. User Mechanism Settings, Operation, and Commands..... | 53 |
| 8.1 Procedure for Setting the Parameters of the User Mechanism..... | 53 |
| 8.2 Description of parameters | 53 |
| 8.2.1 Parameter list..... | 54 |
| 8.2.2 Details of parameters | 56 |
| 8.2.3 About using the linear servo motor | 65 |
| 8.3 Confirmation of connection..... | 67 |
| 8.4 Try to use the mechanical additional axis. | 68 |
| 8.4.1 Turn ON the power supply | 68 |
| 8.4.2 Move the user mechanism. | 69 |
| 8.4.3 Setting the Origin | 70 |
| 8.4.4 Create a program | 71 |
| 8.4.5 Execute a program..... | 71 |
| 8.4.6 End the operation..... | 71 |
| 8.5 Operation of the User Mechanism..... | 72 |
| 8.5.1 Brake release | 72 |
| 8.5.2 Origin setting | 72 |
| 8.5.3 Servo ON/OFF | 72 |
| 8.5.4 Jog operation | 72 |
| 8.5.5 Operation of position variable | 73 |
| 8.5.6 Operation | 73 |

| | |
|-----------------------------------------------------------------|-----|
| 8.5.7 Stop..... | 73 |
| 8.5.8 Error resetting | 74 |
| 8.6 Explanation of commands | 75 |
| 8.6.1 Position variables | 75 |
| 8.6.2 Commands | 76 |
| 8.6.3 Limitation when using user mechanism | 83 |
| 8.7 Example of System Configuration of the User Mechanism | 84 |
| 8.7.1 Rotation table system..... | 84 |
| 8.7.2 System with multiple axes | 92 |
| 9. Such a Case | 101 |
| 10. Appendix | 102 |
| 10.1 Error list..... | 102 |
| 10.2 Add axis limit switch function..... | 104 |
| 10.2.1 Outline | 104 |
| 10.2.2 Setting | 105 |
| 10.2.3 Error list..... | 107 |

1. How to use the instruction manual

This manual describes the functions, which are added or changed in the additional axis interface. For the functions and their operation methods provided in the standard controller, refer to separate "Instruction Manual/ Controller setup, basic operation, and maintenance". Moreover, for the functions and their operation methods prepared in the servo amplifier and servomotor, refer to "Instruction Manual for Servo Amplifier and Servomotor".

1.1 Content of instruction manual

Through the following configuration, this manual describes the functions, which are added or changed in the additional axis interface.

Table 1.2.1 Content of instruction manual

| Chapter | Title | Content |
|---------|---------------------------------------------------------------------|-------------------------------------------------------------------------------------------------------------------------------------------------------------------------------------------------------------------------------------------------------------------------------------------------|
| 1 | How to use the instruction manual | This section describes how to use this document (Additional Axis Interface User's Manual). |
| 2 | Flow of works | This section describes the work required to build an additional axis system. Please follow the procedure completely. |
| 3 | Additional axis function | This section describes the functions and specifications of the additional axis interface. |
| 4 | Confirmation of product | Check whether all products required for building a system are available, and the version of the controller for compatibility. |
| 5 | Connection and Wiring | This section describes the connection and wiring of the controller and the servo system. Be sure to install the servo amplifier and the motor exactly as instructed in this section. |
| 6 | Servo system setting | This section describes how to set up the servo system. |
| 7 | Setting, Operation and Command Explanation of Robot Additional Axis | The case in which the additional axis is controlled in synchronization with the robot arm (mechanism No. 1) is described. A series of operation methods from the parameter setting, start to the end, and the added and changed commands are described. |
| 8 | User Mechanism Settings, Operation, and Commands | The case in which the additional axis is used as the multi mechanism (controlled asynchronously with the robot arm) is described. A series of operation methods from the parameter setting, start to the end, and the added and changed commands are described. |
| 9 | Such a Case | When the additional axis interface is used, a poor motion or error may occur. For the solving methods, refer to this chapter as necessary. |
| 10 | Appendix | Since the errors added to use the additional axis interface are herein described, refer to them as necessary. For the parameter error list and others not directly concerned with the commands and additional axis connection, refer to the items of "Instruction Manual for Robot Controller". |

1.2 Codes of instruction manual

This manual uses the codes and their expression as shown in Table 1.2.1.

Table 1.2.1 Codes of instruction manual

| Code | Meaning |
|------------------------------|----------------------------------------------------------------------------------------------------------------------------------|
| [JOG] | If [] is added in the sentence as shown on the left, it means the key of the teaching pendant. |
| [SERVO] + [RESET] (A) (B) | It means that (B) key is pressed with (A) key pressed. This example means that [RESET] key is pressed with [00SERVO] pressed. |
| T/B | It means teaching pendant. |

1.How to use the instruction manual

1.3 Terms used in instruction manual

The following terms are used in this manual.

(1) Additional axis interface

The additional axis interface means a general-purpose servo amplifier control interface which is used in combination with controller (CR800 series).

(2) Standard system

This means the system which does not use the additional axis interface, a configuration of controller and robot arm.

(3) Additional axis system

This means the system which uses the additional axis interface, a configuration of controller (CR800 series), robot arm and additional axis.

(4) Servo system

A total of the servo amplifier and servomotor is called the servo system.

(5) Additional axis

This means the axis, which is controlled with the additional axis interface. The robot additional axis and mechanical additional axis are generally called the additional axes.

(6) Robot additional axis

The robot additional axis means the axis, which is added to the robot in order to control the additional axis in synchronization with the robot arm (mechanism No. 1). As special, the axis used as the 7th axis of the robot is called the additional axis 1, and the axis used as the 8th axis is called the additional axis 2.

(7) User mechanism

When the additional axis is used as a multi-mechanism (controlled asynchronously with the robot arm), each axis of the mechanism is called a user mechanism.

(8) Multi mechanism

The multi mechanism means that plural robots (mechanism) are controlled from one controller.

2. Flow of works

The flow of the works for the additional axis interface is shown below. Referring to the following, proceed with the works without excess and shortage.

2.1 Flow of works

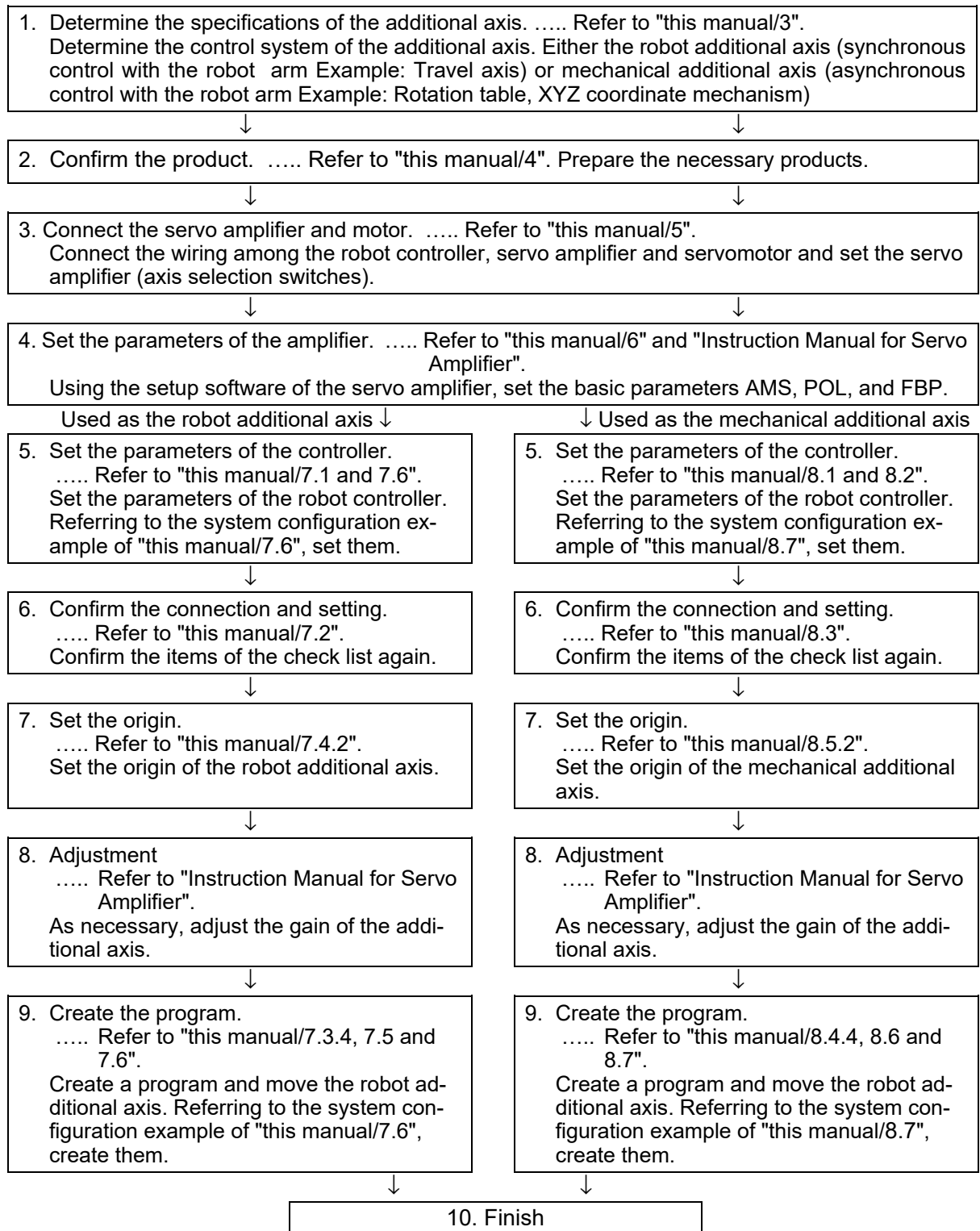

3. Additional axis function

3. Additional axis function

This section describes the functions and specifications of the additional axis.

3.1 What is the additional axis function?

The additional axis function is an function, which uses the general-purpose servo amplifier (Refer to "Table 3.1.) of Mitsubishi and the corresponding servomotors in order to allow the plural above servomotors to be controlled from the robot controller.

Table 3.1 Applicable servo systems

| Maker name | Servo amplifier name | Type |
|---------------------------|----------------------|------------------------------------------------------------------|
| Mitsubishi Electric Corp. | MELSERVO-J4 series | MR-J4-*B (ABS specifications) MR-J4W*-*B (ABS specifications) |

Refer to "3.4. Additional axis function specifications" for the details of corresponding servo amplifier.

3.2 System configuration example of additional axis function

If the function of the additional axis is used, the following system can be configured.

- (1) Robot additional axis Like the travel axis, etc., the axis starts moving and stops moving (as a part of the robot) in synchronization with the robot arm.
- (2) Mechanical additional axis Like the rotation table, positioning device, etc., the axis is separately (asynchronously) controlled regardless of the robot arm.

"Fig. 3.2.1" shows the system in which the robot arm is arranged on the travel axis. In this case, the travel axis is a robot additional axis (controlled in synchronization with the robot arm).

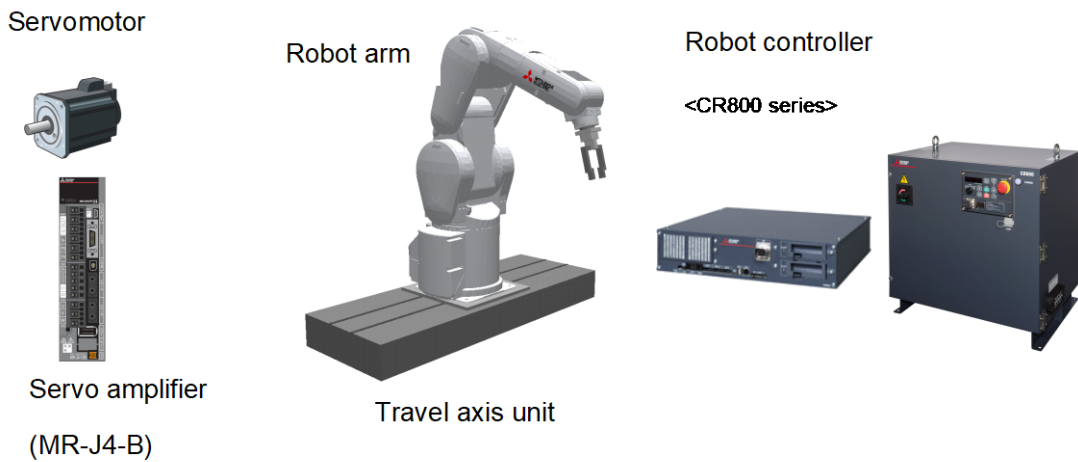

Note) The fig of the robot arm is the vertical multi-joint type 6 axis robot's example.

Fig. 3.2.1 Travel axis system (an example)

3. Additional axis function

"Fig. 3.2.2 " shows such an example as the rotation table is used as the mechanical additional axis (used as the multi mechanism).

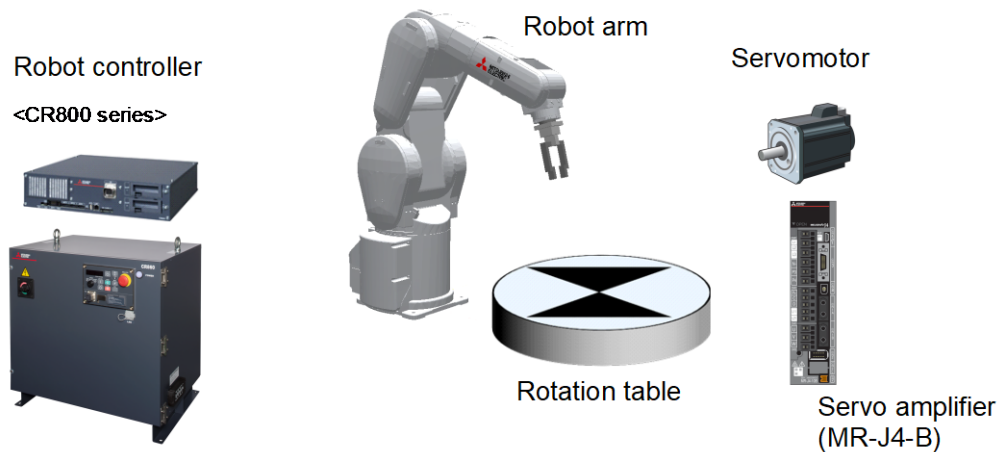

Note) The fig of the robot arm is the vertical multi-joint type 6 axis robot's example.

Fig. 3.2.2 Rotation table system (an example)

The figure below shows an example of a system consisting of a standard robot, a vertical moving axis and a rotary axis.

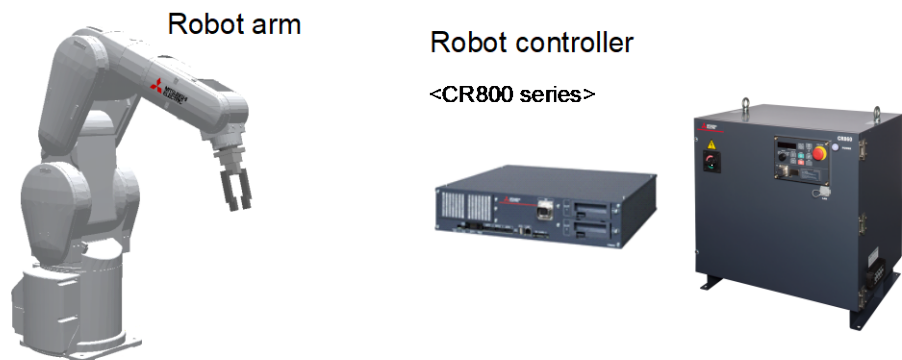

Note) The fig of the robot arm is the vertical multi-joint type 6 axis robot's example.

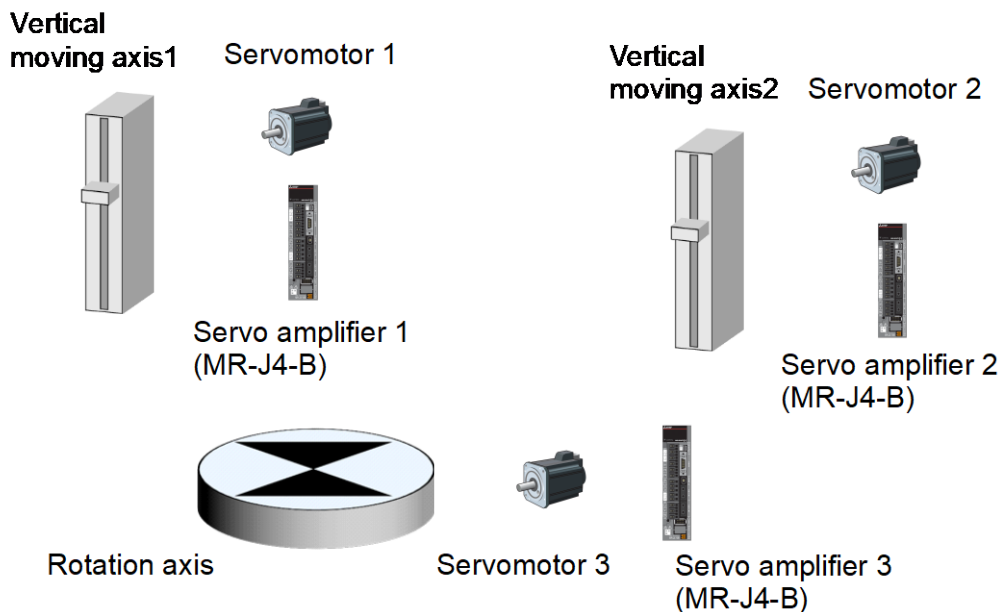

Fig. 3.2.3 Multiple axis system (an example)

3.3 Additional axis interface functions

The additional axis interface has the following functions.

- (1) The robot controller can control a maximum of 2 axes such the travel axis, etc., as the 7th and 8th axes of the robot arm.
- (2) The robot controller can control the rotation axis and linear drive axis as the multi mechanism. Here, a maximum of 2 mechanisms excluding the robot arm, and a maximum of 3 axes per mechanism can be controlled.
- (3) As for the user mechanism, a maximum of three axes per unit, i.e., the first, second and third axes, can be controlled.
- (4) The additional axes can be done the jog operation from the teaching pendant.
- (5) The additional axes can be programmed with MELFA-BASICVI and MELFA-BASICV language methods.
- (6) The robot and robot additional axis can be synchronously controlled
(Refer to "this manual/7.5.2Synchronous control of robot additional axis (travel axis) ".).

3.4 Additional axis function specifications

The additional axis function specifications are as follows.

Table 3.4.1 Additional axis function specifications

| Item | Unit | Specification of robot additional axis | Specification of user mechanism |
|--------------------------------------------|-----------------|---------------------------------------------------------------------------------------------------------------|---------------------------------|
| Number of controllable robots (mechanisms) | Unit/Controller | 3 | |
| Number of control axes | Axis/Controller | 8 | |
| Number of control axes | Axis | 2 | 3 |
| Applicable amplifier | | MELSERVO-J4 series ^{Note4)} | |
| Applicable encoder | | ABS method only ^{Note1)} | |
| Communication method | | SSCNET III/H (differential communication) of Mitsubishi | |
| Program method | | MELFA-BASICVI, MELFA-BASICV | |
| Control function | | Synchronous interpolation control | |
| Path control method | | CP control/PTP control | PTP control |
| Acceleration/ deceleration | | The trapezoidal method/acceleration/deceleration time pattern can be set. | |
| Position control | | Distance control/angle control can be selected. Actual value control with pitch/deceleration ratio setting | |
| Minimum command value | mm or deg | 0.01 or 0.001 ^{Note2)} | |
| Maximum motion range | mm or deg | Max. -131072.00 to +131072.00 ^{Note3)} | |

Note1) ABS means the absolute value encoder.

Note2) The minimum command value can be changed with the PRGDPNTM parameter. Specifying 2 will set two decimal places and specifying 3 will set three decimal places. Do not specify 1 or smaller value and 4 or larger value. When using values of ± 1000.0 or larger, specify two decimal places. However, the minimum command values for robots with mechanism numbers 2 and 3 will follow the minimum command value for robots or mechanisms with mechanism number 1.

Note3) Limit for each operation can be set at any position. However, the free plane limit cannot be used. The limit of movement range changes with the encoder resolution and the total reduction ratio. Refer to "set up the MEJAR" for details. ("(10) MEJAR (joint operating range)" in "7.1.2. Details of parameters", or "(10) MEJAR (joint operating range)" in "8.2.2. Details of parameters")

Note4) Refer to " Table 3.4.2 Servo amplifier which can be used " for the details of corresponding servo amplifier. Corresponding to absolute position detection system only.

3.Additional axis function

Table 3.4.2 Servo amplifier which can be used

| Maker | Series | Type |
|---------------------------|-------------|------------------------|
| Mitsubishi Electric Corp. | MELSERVO-J4 | MR-J4-□B MR-J4W□-□B |

- Only the absolute position detection system is supported.
- The fully closed control cannot be used.

4. Confirmation of product

This section explains the contents to confirm before using additional axis.

4.1 Necessary products

The products necessary in addition to the standard configuration are listed in "Table 4.1.1 Necessary products". For these main products, refer to "Instruction Manual for Servo Amplifier and Servomotor".

Table 4.1.1 Necessary Products

| No. | Part name | Model name | Q'ty |
|-----|---------------------------------------------------------------------------------------------------------------------------|-------------------------------------------------------------------|--------------------|
| 1 | Servo amplifier, servomotor, option, peripheral device | Refer to "Instruction Manual for Servo Amplifier and Servomotor". | – |
| 2 | Battery (for absolute position detection system) | MR-BAT6V1SET ^{Note1)} | Amplifier quantity |
| 3 | Servo support software (MR Configurator2) (For setup the parameter of servo amplifier and the graph indication, etc.) | SW1DNC-MRC2-E | 1 |
| 4 | Communication cable (Communication cable between personal computer and servo amplifier for setup software) | MR-J3USBCBL3M | 1 |
| 5 | SSCNET III cable | MR-J3BUS*M (* is cable Length) | 1 |

Note1) The battery case (MR-BT6VCASE) and the battery (MR-BAT6V1) are necessary when using MR-J4W□-B.

5.Connection and Wiring

5. Connection and Wiring

This section explains the connection and wiring between the robot controller and the servo system.

5.1 Connection of Robot CPU and servo amplifier

Connect the robot controller and servo amplifier by the SSCNETIII cable. The connection diagram is shown in the following.

In addition,"Fig 5.1.1 Connection of controller and servo amplifier (CR800)" is the example which connects the two sets of servo amplifier.

For details of the contactor control output for the additional axis, refer to the separate "Standard specification manual".

<CR800 controller (front)>

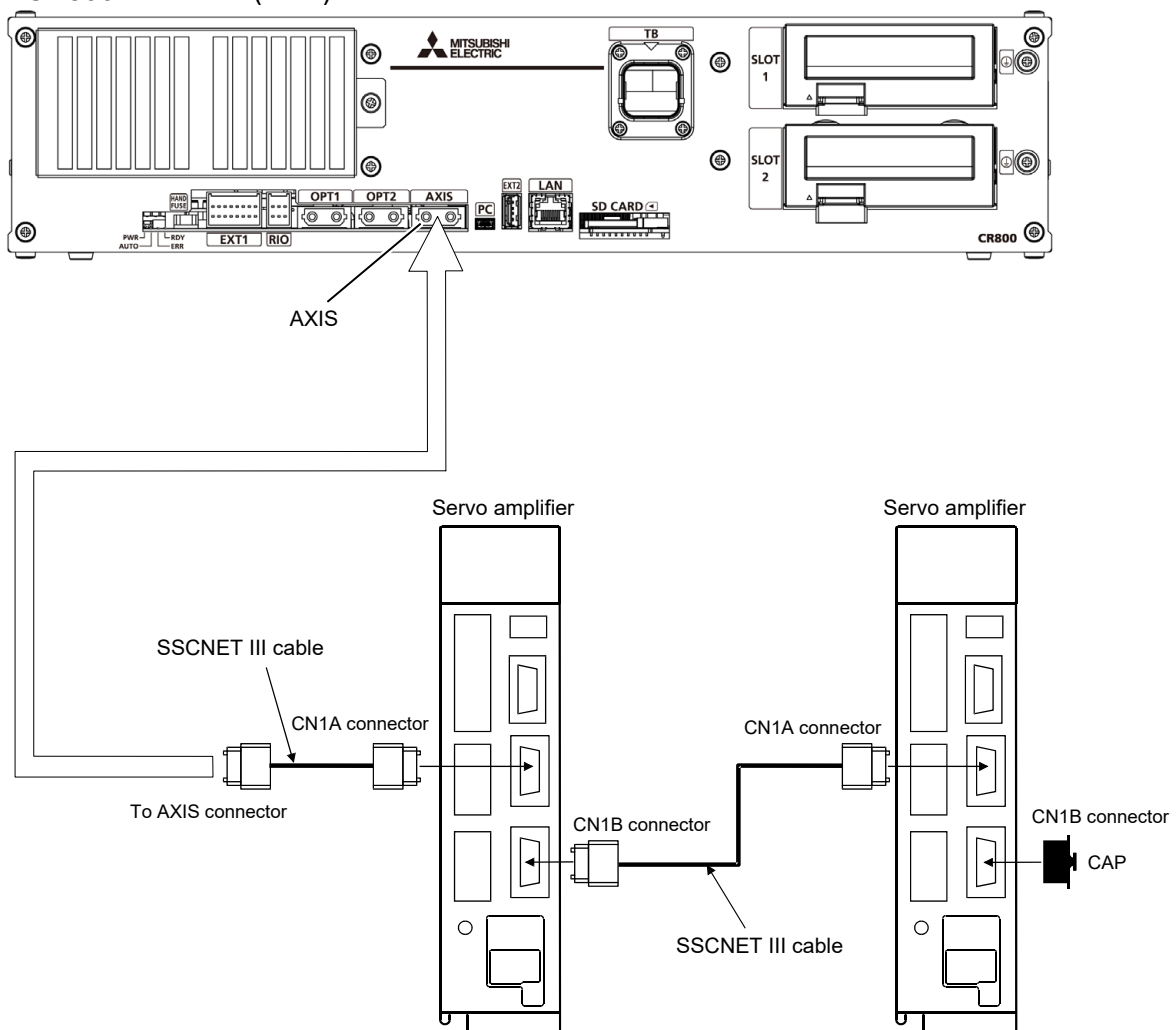

* It cannot communicate, if connection of CN1A and CN1B is mistaken.

Fig 5.1.1 Connection of controller and servo amplifier (CR800)

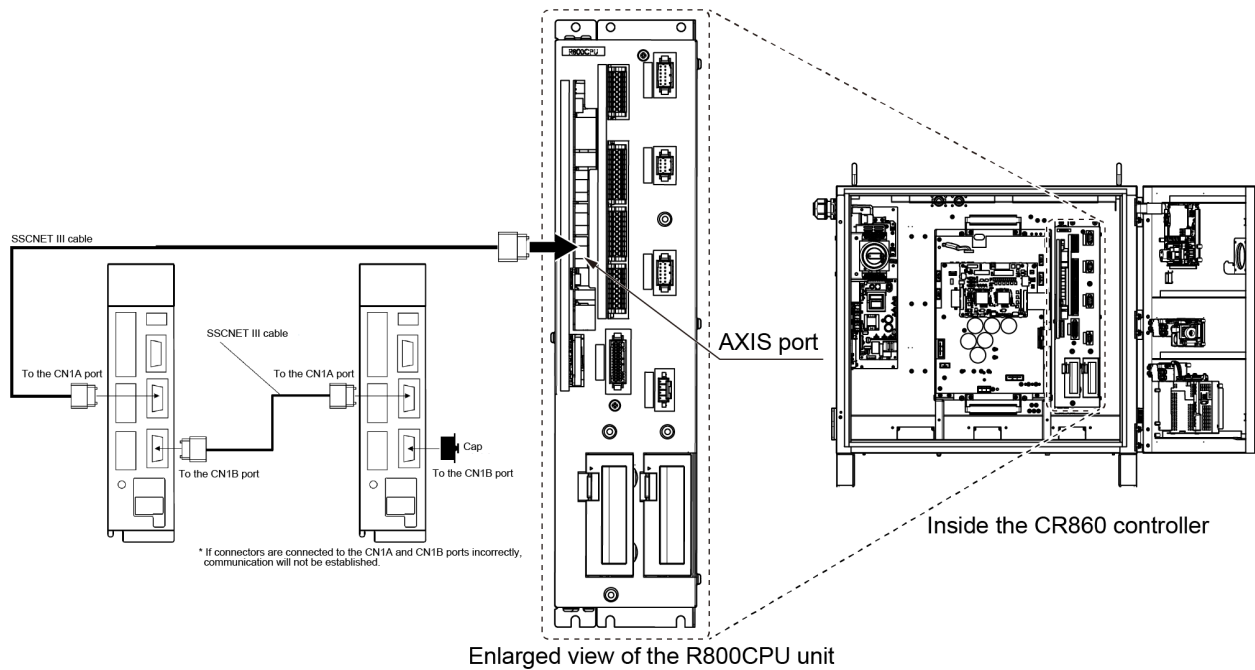

Fig 5.1.2 Connection of controller and servo amplifier (CR860)

To connect a cable to the additional axis port on the R800CPU unit, wire the cable through the cable entrance on the controller.

For details, refer to the "CR860 Controller Instruction Manual/Controller setup, basic operation, and maintenance".

⚠ CAUTION

Please install the connector cap to the connector for communication which does not connect the SSCNETIII cable. There is a possibility of malfunctioning if the cap is not installed. And, if the light from the connector for communication hits upon the eyes, there is a possibility of feeling the incompatibility for the eyes.

5.Connection and Wiring

5.2 Synchronize the power supply of the robot controller

How to synchronize the power supply of the robot controller and the servo amplifier for addition axes is shown.

The servo-ON/OFF status of the addition axis can be synchronized with the servo-ON/OFF status of the robot controller by using the output contact (AXMC).

Please synchronize the power supply of the robot and servo amplifier by the method shown in the following.

*However, this function is available only in the addition axis function, and it is unavailable in the user mechanism's system.

(The individual user mechanism's power supply control is impossible.)

5.2.1 Conceptual diagram of an additional axis system (CR800 controller)

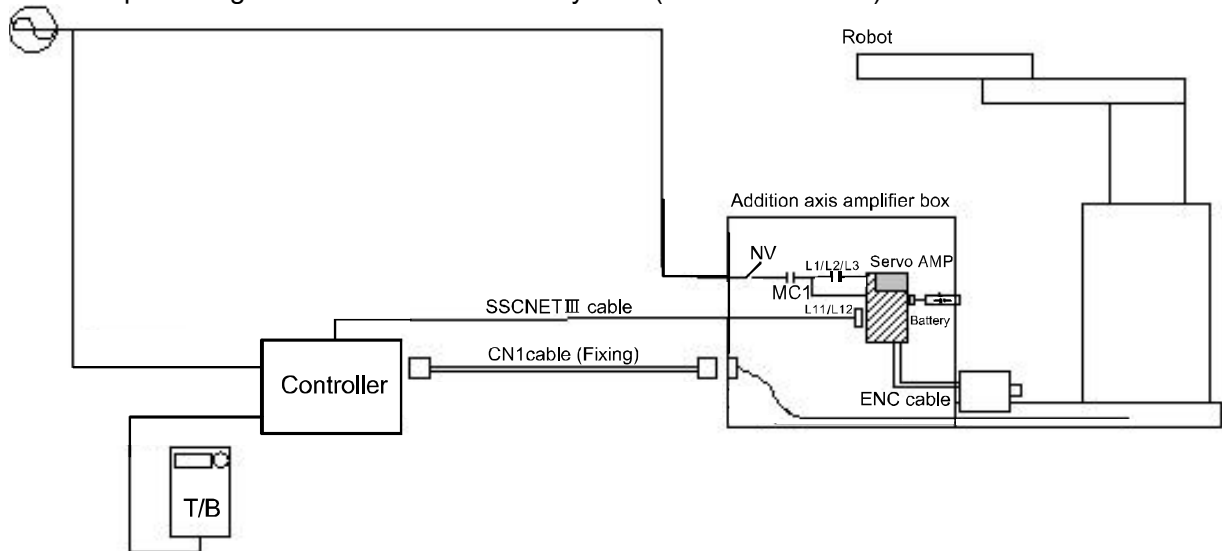

Please arrange the necessary electric parts to the good position, after reading carefully of the technical data of general-purpose servo amplifier.

5.2.2 The power supply synchronization, the main circuit power supply control for addition axes.(Example).

The following figure shows the layout drawings of the output contact (AXMC1). When you are using an additional axis, please perform appropriate circuit connections by referring to these drawings.

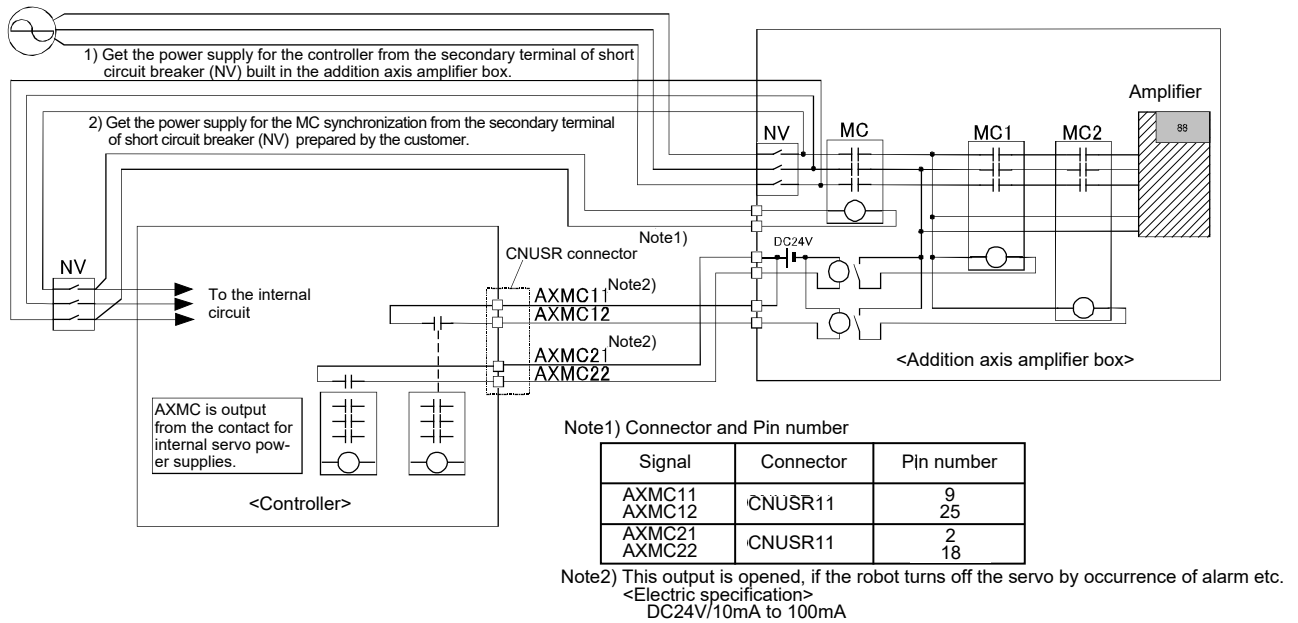
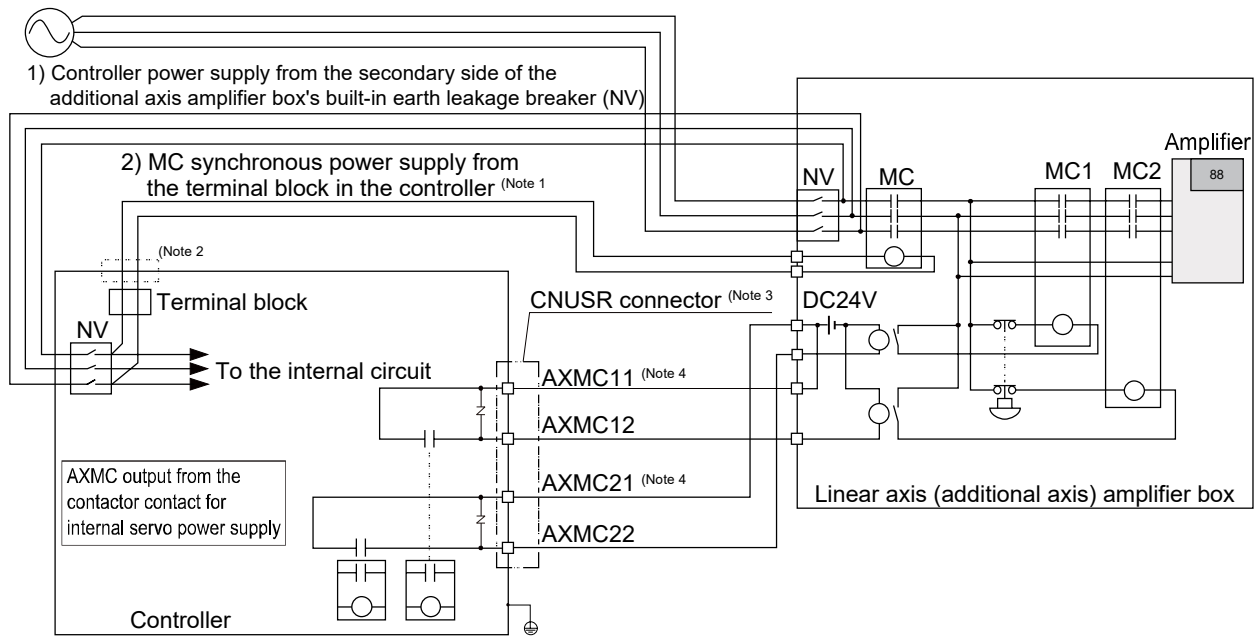

Fig 5.2.1 Example of the standard circuit (CR800 controller)

5.Connection and Wiring



Note 1) Use the terminal block on the front side. Also fix the cable between the cable entrance and terminal block with the stud pin located at the bottom inside the controller.

Note 2) Wire the cable connected to the secondary side of the earth leakage breaker (NV) inside the controller to the outside of the controller through the cable entrance. For information on how to wire cables through the cable entrance, refer to the "CR860 Controller Instruction Manual/Controller setup, basic operation, and maintenance".

Note 3) The following table shows the connector and pin numbers.

| Signal name | Connector | Pin No. |
|-------------|-----------|---------|
| AXMC11 | CNUSR13 | 4 |
| AXMC12 | | 12 |
| AXMC21 | | 8 |
| AXMC22 | | 16 |

Note 4) If the robot servos are turned off due to an alarm or other reasons, this output (contact) will open. Contact capacity: 24V DC/10mA to 100mA

Fig 5.2.2 Example of the standard circuit (CR860 controller)

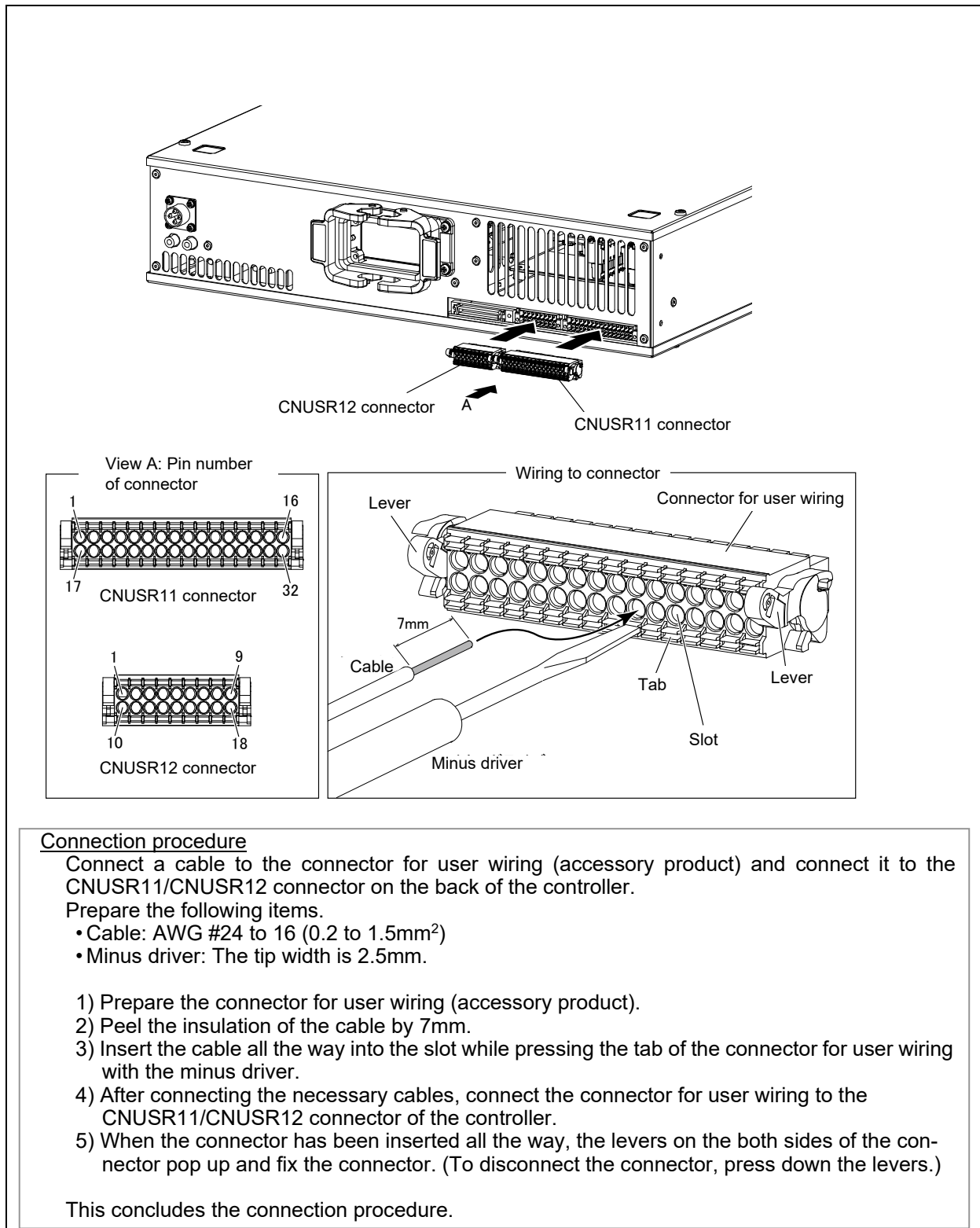

Fig 5.2.3 CNUSR11/CNUSR12 connector(CR800 controller)

5.Connection and Wiring

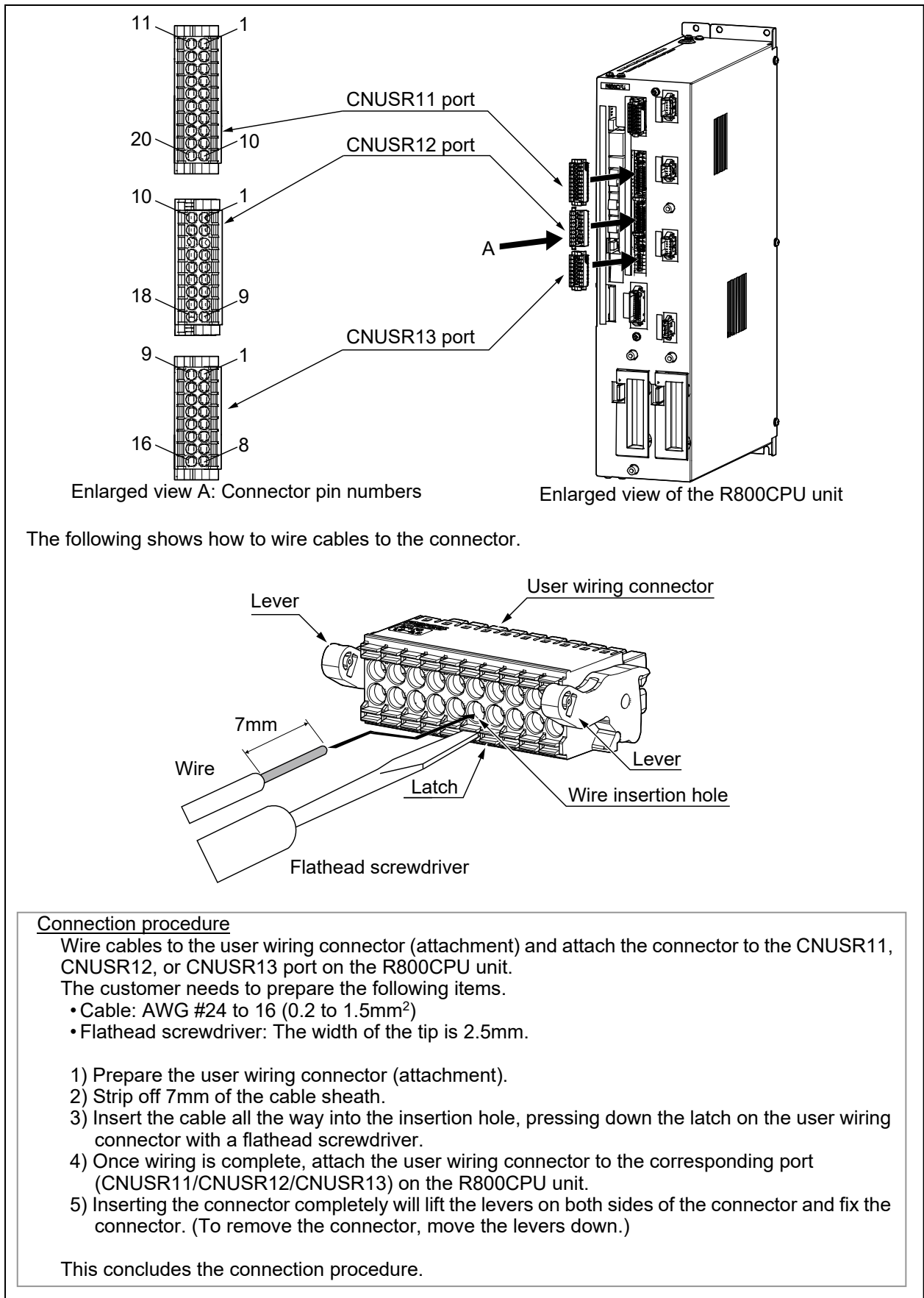

Fig 5.2.4 CNUSR11/CNUSR12/ CNUSR13 connector (CR860 controller)

5.3 Installation of noise filter to power cable

Install the noise filter in the power supply line of addition axis servo amplifier, and the example of connection which reduces the effect by the noise is shown.

Install the noise filter always and please use the robot safely, after confirming the details.

Note) Only the CR800 series controller conforms to the EMC directive.

5.3.1 EMC filter (recommended)

In case of the EMC directive of EN standard, recommend using the following filters. There is what has the large leaking electric current in the EMC filter.

5.Connection and Wiring

(1) Combination with the servo amplifier

Combination of servo amplifier and filter (manufactured by Soshin Electric)

| Servo amplifier | Recommended filter (Soshin Electric) | | | | Mass [kg] |
|---------------------------------------------------|--------------------------------------|-------------------|---------------------|----------------------|-----------|
| | Model | Rated current [A] | Rated voltage [VAC] | Leakage current [mA] | |
| MR-J4-10B(-RJ) to MR-J4-100B(-RJ) | HF3010A-UN ^{Note 1)} | 10 | 250 | 5 | 3.5 |
| MR-J4-200B(-RJ), MR-J4-350B(-RJ) | HF3030A-UN ^{Note 1)} | 30 | | | 5.5 |
| MR-J4-500B(-RJ), MR-J4-700B(-RJ) | HF3040A-UN ^{Note 1)} | 40 | | 6.5 | 6 |
| MR-J4-11KB(-RJ), MR-J4-15KB(-RJ), MR-J4-22KB(-RJ) | HF3100A-UN ^{Note 1)} | 100 | | | 12 |
| MR-J4-60B4(-RJ), MR-J4-100B4(-RJ) | TF3005C-TX | 5 | 500 | 5.5 | 6 |
| MR-J4-200B4(-RJ), MR-J4-700B4(-RJ) | TF3020C-TX | 20 | | | |
| MR-J4-11KB4(-RJ) | TF3030C-TX | 30 | | | |
| MR-J4-15KB4(-RJ) | TF3040C-TX | 40 | | | |
| MR-J4-22KB4(-RJ) | TF3060C-TX | 60 | | | |
| MR-J4-10B1(-RJ) to MR-J4-40B1(-RJ) | TF3010A-UN ^{Note 1)} | 10 | | | 250 |

Note 1) The following surge protector is required to use this EMC filter.
RSPD-250-U4 (manufacturer: OKAYA Electric Industries Co., Ltd.)

Combination of servo amplifier and filter (manufactured by COSEL)

| Servo amplifier | Recommended filter (Soshin Electric) | | | | Mass [kg] |
|------------------------------------|--------------------------------------|-------------------|---------------------|----------------------|-----------|
| | Model | Rated current [A] | Rated voltage [VAC] | Leakage current [mA] | |
| MR-J4-11KB(-RJ) to MR-J4-22KB(-RJ) | FTB-100-355-L ^{Note 1)} | 100 | 500 | 40 | 5.3 |
| MR-J4-22KB4(-RJ) | FTB-80-355-L ^{Note 1)} | 80 | 500 | 80 | 5.3 |

Note 1) The following surge protector is required to use this EMC filter.
RSPD-500-U4 (manufacturer: OKAYA Electric Industries Co., Ltd.)

(2) Connection example

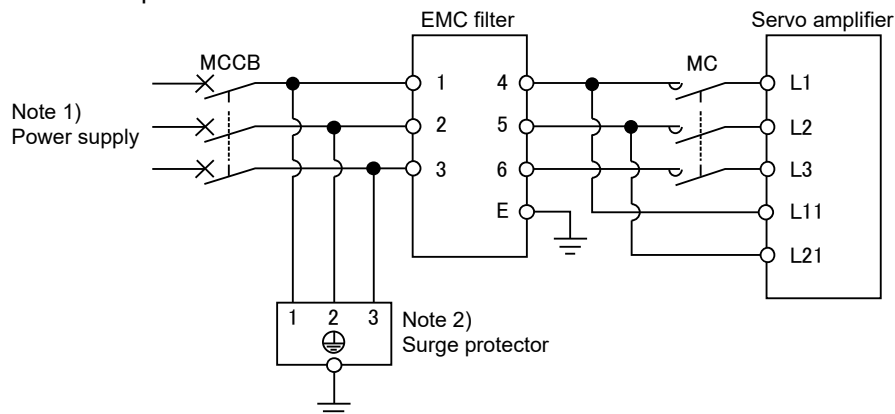

Note 1) In case of the single phase AC200 - 230V power supply, please connect the power supply to L1 and L2, and nothing should be connected with L3. In case of the single phase AC100 - 120V power supply, do not use L3.

Note 2) The figure shows an example of when a surge protector is connected.

Fig. 5.3.1 Combination of MR-J4-B servo amplifier and filter

5.3.2 Line noise filters

This filter is effective in suppressing noises radiated from the power supply side and output side of the servo amplifier and also in suppressing high-frequency leakage current (zero-phase current) especially within 0.5MHz to 5MHz band.

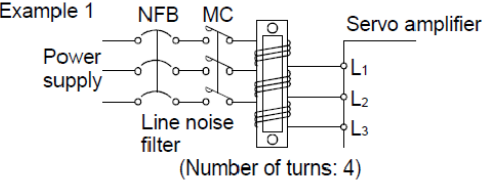
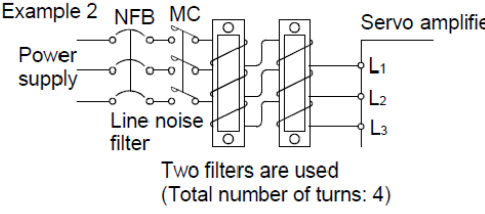
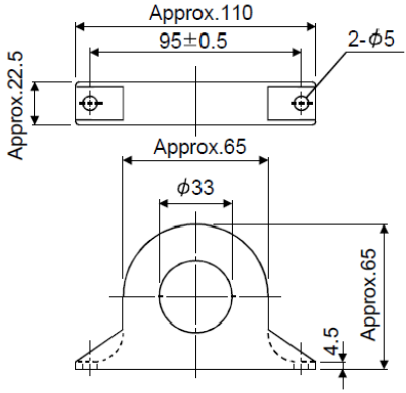
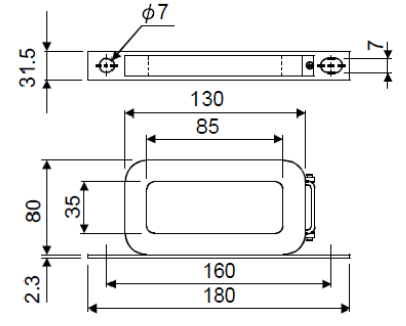
| Connection diagram | Outline drawing [Unit: mm] |
|---------------------------------------------------------------------------------------------------------------------------------------------------------------------------------------------------------------------------------------------------------------------------------------------------------------------------------------------------------------------------------------------------------------------------------------------------------------------------------------------------------------------------------------------------------------------------------------------------------------------------------------------------------------------------------------------------------------------------------------------------------------------------------------------------------------------------------------------------------------------------------------------------------------------------------------------------------------------------------------------------------------------------------------------------------------------------------------------------------------------------------------------------------------------------------------------------------------|-------------------------------------------------------------------------------------------------------------------------------------------------------------------------------------------------------------------------------------------------------------------------------------------------------------|
| <p>Use the line noise filters for wires of the main power supply (L₁ · L₂ · L₃) and of the motor power supply (U · V · W). Pass each of the 3-phase wires through the line noise filter an equal number of times in the same direction. For the main power supply, the effect of the filter rises as the number of passes increases, but generally four passes would be appropriate. For the motor power supply, passes must be four times or less. Do not pass the grounding (earth) wire through the filter, or the effect of the filter will drop. Wind the wires by passing through the filter to satisfy the required number of passes as shown in Example 1. If the wires are too thick to wind, use two or more filters as shown in Example 2. Place the line noise filters as close to the servo amplifier as possible for their best performance.</p> <p>Example 1</p>  <p>(Number of turns: 4)</p> <p>Example 2</p>  <p>Two filters are used (Total number of turns: 4)</p> | <p>FR-BSF01 (for wire size 3.5mm² (AWG12) or less))</p>  <p>FR-BLF (for wire size 5.5mm² (AWG10) or more))</p>  |

5.Connection and Wiring

5.4 Connection example of servo amplifier and servo motor

- (1) Connect the servo amplifier to the servomotor with the servomotor power cable and detector cable. For safety, securely ground them.
- (2) Connect the servomotor power cable to the motor power connector(CNP3) of the servo amplifier.
- (3) Connect the detector cable to the motor detector connector (CN2) of the servo amplifier.
- (4) Connect the ground wire to the ground terminal of the servo amplifier.

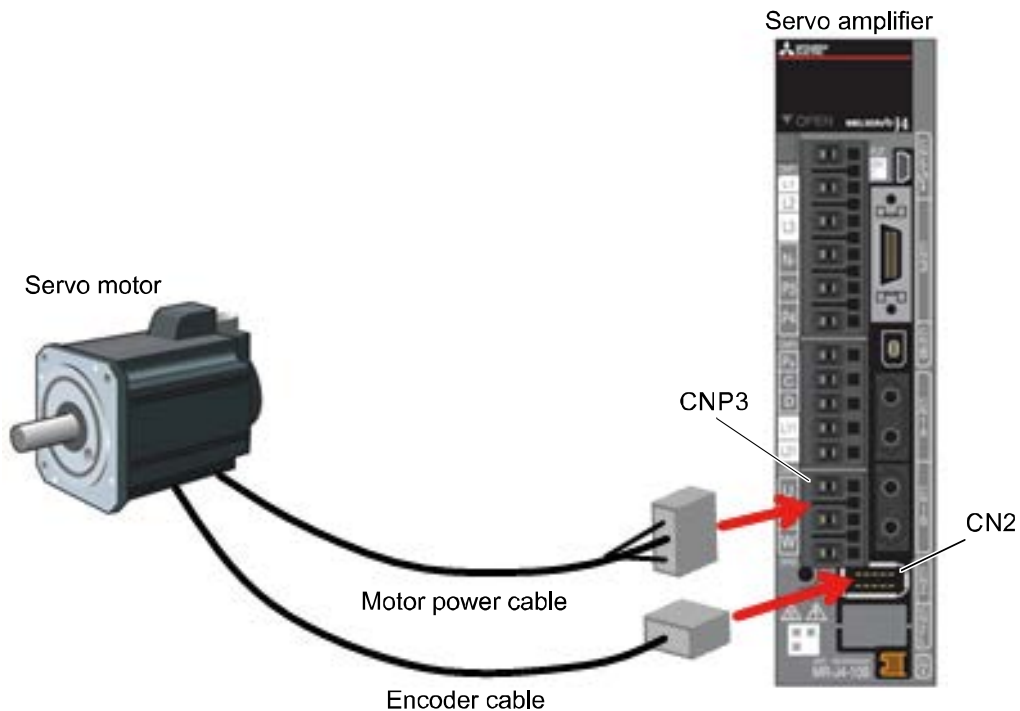

Fig. 5.4.1 Connection example of servo amplifier and servomotor

Note) For details of the connection, refer to "Instruction Manual for Servo Amplifier and Servomotor".



Every time after the motor, absolute position detector or other device is replaced, be sure to check the current position. If there is any displacement of the origin position, set the origin again.

5.5 Installing the Servo System

Install the servo system outside of the controller. For details on installation, refer to the Servo Amplifier Instruction Manual and the Servo Motor Instruction Manual.

6. Servo system setting

6.1 Servo amplifier setting

Using the axis selection rotary switch (SW1) of the servo amplifier, set the axis No. of the servo. For an axis not used, set one of 8 to E. The correspondence between the control axis No. of the servo and the controller axis is determined by setting the parameter. Refer to "this manual/7.1.2Details of parameters" and "this manual/8.2.2Details of parameters". For details of the axis selection rotary switch (SW1) of the servo amplifier, refer to the instruction manual of the servo amplifier.

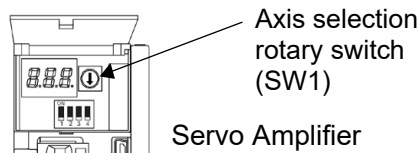

Fig. 6.1.1 Control axis selection switch

Table 6.1.1 Control axis No. of servo

| Setting value of axis selection rotary switch (SW1) | Content |
|-----------------------------------------------------|------------|
| 0 | 1st axis |
| 1 | 2nd axis |
| 2 | 3rd axis |
| 3 | 4th axis |
| 4 | 5th axis |
| 5 | 6th axis |
| 6 | 7th axis |
| 7 | 8th axis |
| 8 | Not used. |
| 9 to F | Do not set |

6.2 Parameter setting of servo amplifier

Set the parameters of the servo amplifier with the servo support software. (Refer to "4.1 Necessary products" in this manual.) Please install to the personal computer previously and prepare.

- (1) The addition axis function does not support the incremental system. Please select the absolute position detection by parameter No.PA03.
- (2) Set the rotation direction (forward run/reverse run) of the motor from the robot controller. Be sure to set the rotation direction of the basic parameter No. 14 POL motor of the servo amplifier to "0" (CCW).
- (3) According to an target operated by the servomotor, set the parameters of the gain, etc. For the details of setting, refer to "Instruction Manual for Servo Amplifier".
- (4) The addition axis function does not support full closed system amplifier. Do not select "Fully closed control mode" in the operation mode selection of the basic setting parameter PA01. If "Fully closed control mode" is selected incorrectly, the movement according to instructions cannot be performed. (The initial setting value is "Standard control mode".)
- (5) When using the linear servo motor and the direct drive motor, it is necessary to use the test mode of operation of the amplifier and to do "magnetic pole position detection" in advance. And, change parameter No.PL01 to disable the magnetic pole detection after completing magnetic pole position detection. (Please refer to the instruction manual of servo amplifier for detail of the method)

7. Setting, Operation and Command Explanation of Robot Additional Axis

When the additional axis is controlled in synchronization with the robot arm (mechanism No. 1), the additional axis added to the robot is called the robot additional axis. This chapter describes a series of the operation methods from the parameter setting of the robot additional axis, start to end, and the added and changed commands.

7.1 Description of parameters

Before use, it is necessary to surely set the following parameters. The parameters set at the robot controller are shown in "Table 7.1.1 Parameter list". For the method to set the parameters, refer to separate "Instruction Manual/ Detailed explanations of functions and operations".



CAUTION

After changing the parameters, turn the power supply of the controller from OFF to ON. Unless this is done, the changed parameters will not be valid.



CAUTION

If any motor, absolute position detector, etc., is replaced or any parameter related to the mechanism and the axis configuration is changed, be sure to confirm the current position. If the origin is dislocated set the origin again. The parameters related to the axis configuration are the multi mechanism applied quantity (AXUNUM), mechanism No. designation (AXMENO), setting axis No. (AXJNT), unit system (AXUNT), rotation direction (AXSPOL) and encoder resolution (AXENCR).



CAUTION

Because to prevent the collision to peripheral equipment, the mechanical stopper, etc., sure set up the operating range (MEJAR) before moving the additional axis.

7.Setting, Operation and Command Explanation of Robot Additional Axis

7.1.1 Parameter list

The parameters are listed in the following "Table 7.1.1 Parameter list". For details of the parameters, refer to "this manual/7.1.2Details of parameters".

Table 7.1.1 Parameter list

| Parameter name | Content | Settable range | Number of elements | Number of elements per axis | Default value | Explanation |
|----------------|---------------------------------|-------------------------------------------|--------------------|-------------------------------|--------------------------|-------------------------------------------------------------------------------------------------------------------------------------------------------------------------------------------------------|
| AXUNUM | Number of multi mechanisms used | 0 to 2 | 1 | – | 0 | Be sure to set "0". |
| AXMENO | Mechanism No. designation | 0 to 3 | 16 | 1 (per control axis of servo) | 0 | Input the mechanism No. to the element which corresponds to the servo control axis No. used and be sure to set "0" for the axis not used. |
| AXJNO | Setting axis No. | 0 to 8 | 16 | 1 (Same as above) | 0 | Designate what number of the axis of the robot arm is used for the additional axis. |
| AXUNT | Unit system | 0 or 1 | 16 | 1 (Same as above) | 0 | Unit system of additional axis 0 ... Angle (degree) 1 ... Length (mm) 2 ... Length (mm) Linear servo use (Set up "2", when using the linear servo) |
| AXSPOL | Rotation direction | 0 or 1 | 16 | 1 (Same as above) | 0 | Set the rotation direction of the motor. 0 ... Forward run (CCW) 1 ... Reverse run (CW) Be sure to set "0" (CCW) at the "POL" parameter of the basic parameter No. 7 of the servo amplifier. |
| AXACC | Acceleration time | Positive real number | 16 | 1 (Same as above) | 0.20 | Acceleration time (Unit: second) of additional axis |
| AXDEC | Deceleration time | Positive real number | 16 | 1 (Same as above) | 0.20 | Deceleration time (Unit: second) of additional axis |
| AXGRTN | Total speed ratio numerator | Positive integer | 16 | 1 (Same as above) | 1 | Total speed ratio numerator of additional axis |
| AXGRTD | Total speed ratio denominator | Positive integer | 16 | 1 (Same as above) | 10 | Total speed ratio denominator of additional axis |
| AXMREV | Rated speed | Positive integer | 16 | 1 (Same as above) | 2000 | Rated speed (Unit: r/min.) of motor or Rated speed (Unit: mm/s.) of linear motor |
| AXJMX | Maximum speed | Positive integer | 16 | 1 (Same as above) | 3000 | Maximum speed (Unit: r/min.) of motor or Maximum speed (Unit: mm/s.) of linear motor |
| AXENCR | Encoder resolution | Positive integer | 16 | 1 (Same as above) | 4194304 | Encoder resolution of motor (Unit: pulse/rev) |
| AXJOGTS | JOG smoothening time constant | Positive real number | 16 | 1 (Same as above) | 150.00 | If it vibrates at JOG, set a larger value. (Unit: ms) |
| MEJAR | Joint operating range | A real number of -131072.00 to +131072.00 | 16 | 2 (per axis of robot) | -80000.0 , 80000.0 | Motion range The minimum values and maximum values are described in this order. (Unit: degree or mm) |
| USERORG | User designated origin | A real number of -80000.00 to 80000.00 | 8 | 2 (Same as above) | 0.00 | Designate the origin position designated by the user. Set a value within the range set in MEJAR (joint operating range). (Unit: degree or mm) |

7.Setting, Operation and Command Explanation of Robot Additional Axis

7.1.2 Details of parameters

Here, the parameters are described in details.

- (1) AXUNUM (number of multi mechanisms used)
- (2) AXMENO (mechanism No. designation)
- (3) AXJNO (Setting axis No.)
- (4) AXUNT (unit system)
- (5) AXSPOL (motor rotation direction)
- (6) AXACC (acceleration time) · AXDEC (deceleration time)
- (7) AXGRTN (total speed ratio numerator) · AXGRTD (total speed ratio denominator)
- (8) AXMREV (rated rotation speed) · AXJMX (maximum rotation speed) · AXENCR (encoder resolution)
- (9) AXJOGTS (JOG smoothing time constant)
- (10) MEJAR (joint operating range)
- (11) USERORG (user designated origin)

Moreover, the parameter elements of (2) to (9) correspond to the control axis Nos. of the servo as shown in "Fig. 7.1.1 Control No. and parameter element of servo". If any personal computer support software (which enables the program editing, parameter setting, various monitors, etc., of the robot) is used, (10) and (11) are the mechanical parameters and the others are arranged in the common parameters.

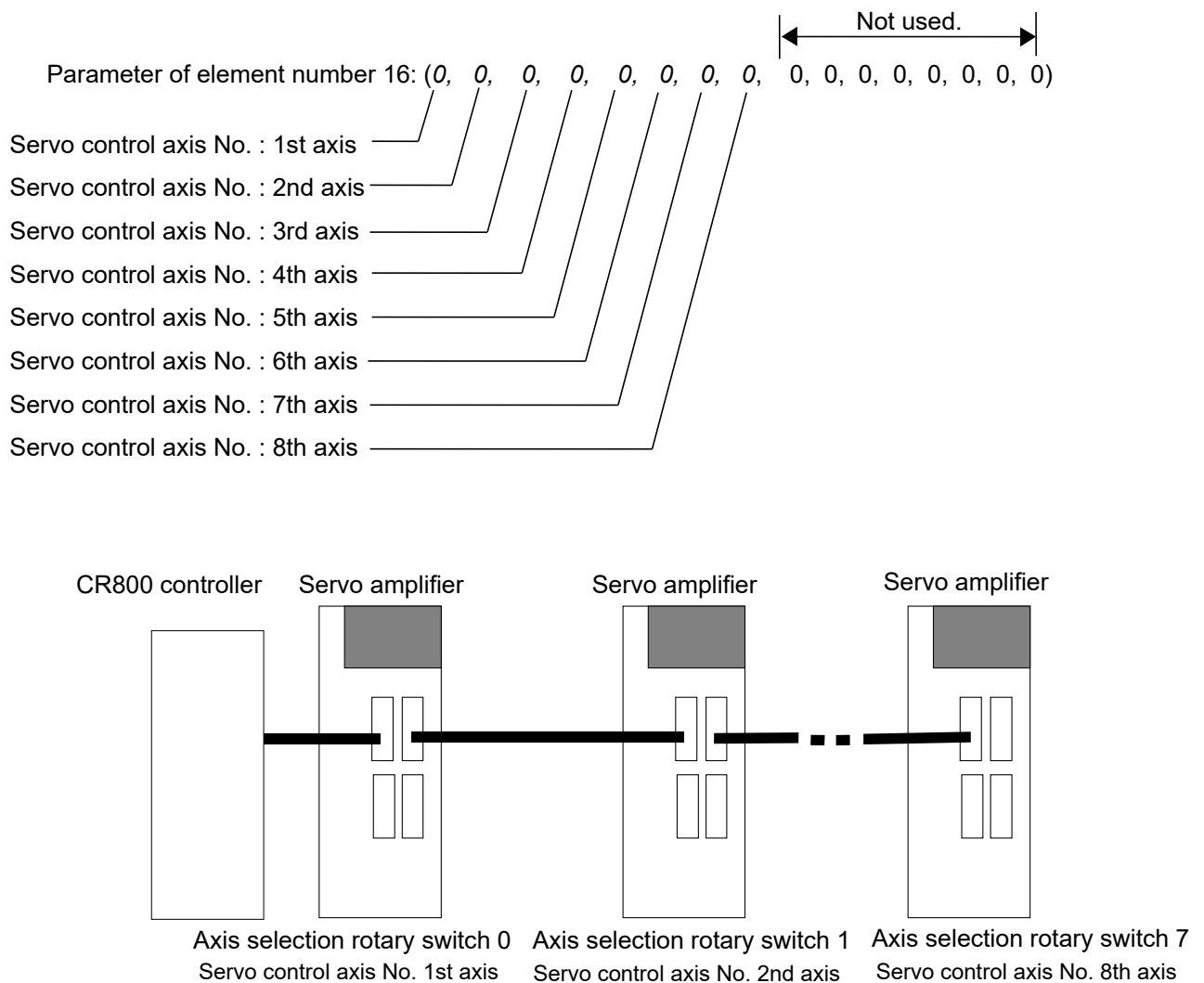

Fig. 7.1.1 Control No. and parameter element of servo

7. Setting, Operation and Command Explanation of Robot Additional Axis

(1) AXUNUM (number of multi mechanisms used)

This parameter designates how many mechanisms are connected when the additional axis is used as the multi mechanism. To control the additional axis in synchronization with the robot arm, be sure to set "0" at (robot additional axis).

| | |
|-----------------------------------------------|---|
| When it is used as the robot additional axis, | 0 |
|-----------------------------------------------|---|

(2) AXMENO (mechanism No. designation)

This parameter sets which mechanism the servomotor connected to the servo amplifier is connected to regarding each axis. To control the additional axis in synchronization with the robot arm, be sure to set "1" at (robot additional axis).

[Example]

When the servomotor set "Control axis No. of servo" as the 1st axis is controlled in synchronization with the robot arm (mechanism No. 1), set the AXMENO parameter as follows.

AXMENO = 1, 0, 0, 0, 0, 0, 0, 0, 0, 0, 0, 0, 0, 0, 0 (Set "1" to the 1st element.)

(3) AXJNO (Setting axis No.)

Regarding each axis, this parameter sets what number axis of the robot or mechanism the servomotor is used. To change an axis No. which has been set once (example: 7th axis → 8th axis), first set "0" at AXMENO and turn the power supply of the controller from OFF to ON. The default value is "0".

| | |
|-------------------|---|
| Additional axis 1 | 7 |
| Additional axis 2 | 8 |

[Example]

When the servomotor set "Control axis No. of servo" as the 1st axis is used as the additional axis 1,

AXJNO = 7, 0, 0, 0, 0, 0, 0, 0, 0, 0, 0, 0, 0, 0, 0 (Set "7" to the 1st element.)

(4) AXUNT (unit system)

Regarding each axis, this parameter sets the unit system of the servomotor, which can be used.

| | |
|-----------------------------------------------------------|---|
| Used as the rotation axis. (Unit: degree) (Default value) | 0 |
| Used as the linear drive axis (Unit: mm) | 1 |
| Use the linear servo (Unit: mm) | 2 |

[Example]

When the servomotor set "Control axis No. of servo" as the 1st axis is used as the linear drive axis (Unit: mm),

AXUNT = 1, 0, 0, 0, 0, 0, 0, 0, 0, 0, 0, 0, 0, 0, 0 (Set "1" to the 1st element.)

When linear servo is connected to the axis which set to 2nd axis as the "Control axis No. of servo"

AXUNT = 0, 2, 0, 0, 0, 0, 0, 0, 0, 0, 0, 0, 0, 0, 0 (Set "2" to the 2nd element.)

7. Setting, Operation and Command Explanation of Robot Additional Axis

(5) AXSPOL (motor rotation direction)

Regarding each axis, this parameter sets in which direction the servomotor is rotated when the joint position data is increased. The rotation direction is illustrated in the parameter details of "Instruction Manual for Servo Amplifier".

Moreover, set the rotation direction with the robot controller.

| | |
|-------------------------------------------------------------------------------------|---|
| Forward run (CCW) (default value) as the value of the joint coordinate is increased | 0 |
| Reverse run (CW) as the value of the joint coordinate is increased | 1 |

Here, be sure to set "POL" parameter of the basic parameter No. 7 of the servo amplifier to "0" (CCW).

[Example]

When the rotation direction of the servomotor set "Control axis No. of servo" as the 1st axis is reversed as the joint position data is increased,

AXSPOL = 1, 0, 0, 0, 0, 0, 0, 0, 0, 0, 0, 0, 0, 0, 0 (Set "1" to the 1st element.)

(6) AXACC (acceleration time) · AXDEC (deceleration time)

Regarding each axis, these parameters set the acceleration/deceleration time from the stop state to the maximum speed when the override of the servomotor which can be used is 100%. The default value is 0.20 (seconds).

[Example]

When the acceleration/deceleration time of the servomotor set "Control axis No. of servo" as the 1st axis is set as follows,

| | |
|-------------------|----------------|
| Acceleration time | 0.40 (seconds) |
| Deceleration time | 0.40 (seconds) |

AXACC = 0.40, 0.20, 0.20, 0.20, 0.20, 0.20, 0.20, 0.20, 0.20, 0.20, 0.20, 0.20, 0.20, 0.20, 0.20, 0.20
(Set "0.40" to the 1st element.)

AXDEC = 0.40, 0.20, 0.20, 0.20, 0.20, 0.20, 0.20, 0.20, 0.20, 0.20, 0.20, 0.20, 0.20, 0.20, 0.20, 0.20
(Set "0.40" to the 1st element.)

(7) AXGRTN (total speed ratio numerator) · AXGRTD (total speed ratio denominator)

These parameters set the numerator and denominator of the total speed ratio of the servomotor which can be used. As the total speed ratio, set a fraction whose numerator and denominator are both integers. (When the ratio is 1/18.5, set 2/37.) The default value of AXGRTN is "1", and the default value of AXGRTD is "10". When using the linear servo motor, the setting methods differ. Please refer to "this manual/7.1.3 About using the linear servo motor".

[Example]

When the total speed ratio of the servomotor axis set "Control axis No. of servo" as 1st axis is 25/8(mm/rev),

AXGRTN = 25, 1, 1, 1, 1, 1, 1, 1, 1, 1, 1, 1, 1, 1, 1 (Set "25" to the 1st element.)

AXGRTD = 8, 10, 10, 10, 10, 10, 10, 10, 10, 10, 10, 10, 10, 10, 10 (Set "8" to the 1st element.)

The total speed ratio of the direct moving axis is calculated as follows. From the relationship of the gear ratio and ball screw lead of "Fig. 7.1.2 Inside of direct moving unit", the movement amount of the load per rotation of the motor is as follows.

$$5 \times 5/8 = 25/8 \text{ [mm/rev]}$$

Accordingly, since the motor speed when the load is moved 1mm becomes 8/25 rotation, the total speed ratio becomes as follows.

$$\text{AXGRTN/AXGRTD} = 1 / (8/25) = 25/8$$

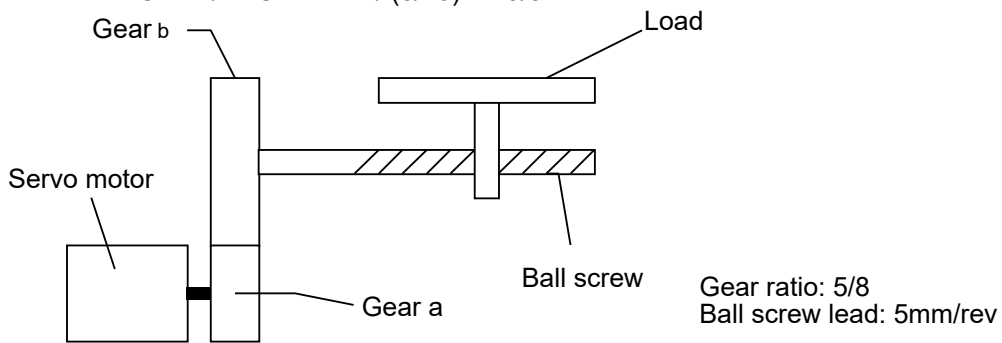

Fig. 7.1.2 Inside of direct moving unit

The total speed ratio of the rotation axis is calculated as follows. When the table of "Fig. 7.1.3 Inside of rotation table" rotated one rotation (360 degrees), the motor speed becomes 10 rotations. Therefore, the total speed ratio becomes as follows.

$$\text{AXGRTN/AXGRTD} = 1/10$$

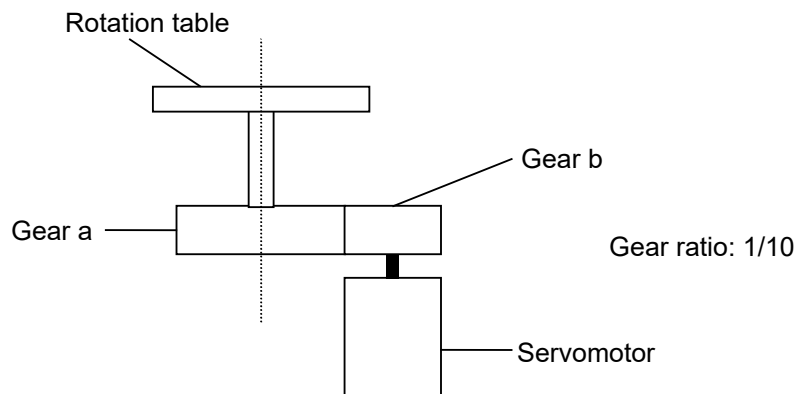

Fig. 7.1.3 Inside of rotation table

7. Setting, Operation and Command Explanation of Robot Additional Axis

- (8) AXMREV (rated rotation speed) · AXJMX (maximum rotation speed) · AXENCR (encoder resolution)

These parameters set the properties of the servomotor, which can be used. Referring to the specifications in "Instruction Manual for Servo Amplifier", set the values which are suitable for the applied servomotor. The default value of AXMREV is 2000(r/min.), the default value of AXJMX is 3000(r/min.) and the default value of AXENCR is 4194304 (pulse/rev). When using the linear servo motor, the setting methods differ. Please refer to "this manual/7.1.3 About using the linear servo motor".

[Example]

When the properties of the servomotor set "Control axis No. of servo" as the 1st axis are as follows.

| | |
|--------------------|--------------------|
| Rated speed | 3000 (r/min) |
| Maximum speed | 4000 (r/min) |
| Encoder resolution | 131072 (pulse/rev) |

AXMREV = 3000, 2000, 2000, 2000, 2000, 2000, 2000, 2000, 2000, 2000, 2000, 2000, 2000, 2000, 2000, 2000, 2000, 2000

(Set "3000" to the 1st element.)

AXJMX = 4000, 3000, 3000, 3000, 3000, 3000, 3000, 3000, 3000, 3000, 3000, 3000, 3000, 3000, 3000, 3000, 3000, 3000

(Set "4000" to the 1st element.)

AXENCR = 131072, 4194304, 4194304, 4194304, 4194304, 4194304, 4194304, 4194304, 4194304, 4194304, 4194304, 4194304, 4194304, 4194304, 4194304

(Set "131072" to the 1st element.)



CAUTION

In MANUAL mode, the maximum speed of an additional axis is 10% of the value set in parameter AXJMX.

Therefore, when operating the robot mounted on a travel axis (additional axis) in MANUAL mode, set parameter AXJMX so that the operating speed (composite speed) of the robot including the travel axis does not exceed the safe speed (250 mm/s).

- (9) AXJOGTS (JOG smoothening time constant)

Set this parameter to reduce the vibration if it occurs during jog of the additional axis. If any excessive value is set, the acceleration/deceleration time becomes long during jog operation. The settable value is in the range of positive real numbers. The default value is 150.00 (ms).

[Example]

When this parameter value is set to "200.00" against vibration of the axis set "Control axis No. of servo" as the 1st axis,

AXJOGTS = 200.00, 150.00, 150.00, 150.00, 150.00, 150.00, 150.00, 150.00, 150.00, 150.00, 150.00, 150.00, 150.00, 150.00, 150.00, 150.00, 150.00

(Set "200.00" to the 1st element.)

7. Setting, Operation and Command Explanation of Robot Additional Axis

(10) MEJAR (joint operating range)

For this parameter, set the motion range of the additional axis in order of minimum value and maximum value. Since the 1st to 12th elements are the values set for the axes of the robot, never change the values. The settable values are real numbers in the range of -131072.00 to +131072.00. The default values are -80000.00 and 80000.00.

[Example]

When the motion range of the additional axis 1 (7th axis) is set for the robot of RV-7FR as follows,

Minimum value -2000mm
Maximum value 3000mm

MEJAR = -240.00, 240.00, -115.00, 125.00, 0.00, 156.00, -200.00, 200.00, -120.00, 120.00,
-360.00, 360.00, -2000.00, 3000.00, -80000.00, 80000.00
(+/- value of L1(J7) axis.), (+/- value of L2(J8) axis.)

(Set "-2000.00" to the 13th element and "3000.00" to the 14th element.)

<Note>

Cannot move to the position exceeding operating range as following. Please set up the operating range (MEJAR) in the range which satisfies the following formula sure. Take care since the operating range changes with set-up values of the encoder resolution setup (AXENCR) and the total reduction ratio setup (AXGRTN, AXGRD)

| | Operatingrange |
|------------------------|------------------------------------------------------------------------------------------------------------------------------------------------------------------------------------------------------------------------|
| Linear axis (mm) | $-\left(\frac{2^{31}}{\text{AXENCR}} - 50\right) \times \frac{\text{AXGRTN}}{\text{AXGRD}} \leq x \leq \left(\frac{2^{31}}{\text{AXENCR}} - 50\right) \times \frac{\text{AXGRTN}}{\text{AXGRD}}$ |
| Rotation axis (deg) | $-360 \times \left(\frac{2^{31}}{\text{AXENCR}} - 50\right) \times \frac{\text{AXGRTN}}{\text{AXGRD}} \leq x \leq 360 \times \left(\frac{2^{31}}{\text{AXENCR}} - 50\right) \times \frac{\text{AXGRTN}}{\text{AXGRD}}$ |

(x : The position which robot moves (coordinate value))

<Example>

If the axis is the rotation type, and if the encoder resolution and the total reduction ratio are the following, the operating range (setting value of MEJAR) is -1663.20 (deg) to +1663.20 (deg).

<Encoder resolution, the total reduction ratio>

AXENCR=4194304
AXGRTN=1
AXGRD=100

(11) USERORG (user designated origin)

This parameter sets the origin position set when the user designated origin is set. The origin of the additional axis set here is also reflected on the other origin setting method (mechanical stopper, jig and ABS system). The settable value is in the range of -80000.00 to 80000.00, being a real number in the range set at MEJAR (joint operating range).

[Example]

When the user designated origin of the additional axis 1 (7th axis) is set for the robot of RV-7FR as follows,

Origin position designated by the user 1500mm

USERORG = 0.00, 0.00, 90.00, 0.00, 0.00, 0.00, 1500.00, 0.00
(Set "1500.00" to the 7th element.)

7.Setting, Operation and Command Explanation of Robot Additional Axis

7.1.3 About using the linear servo motor

When using the linear servo motor, set the total speed ratio parameter (AXGRTN/AXGRTD), the encoder resolution parameter (AXENCN), and the rated speed parameter (AXMREV/AXJMX) as follows.

(1) Resolution related parameter (AXGRTN/AXGRTD/AXENCN) setting.

Set up the linear servo motor moving distance per one pulse of linear encoder as follows.

$$\text{Moving distance per one pulse (mm)} = \frac{\text{AXGRTN}}{\text{AXGRTD}} \times \frac{1}{\text{AXENCN}}$$

[Example]

When the resolution of linear servo motor which set the "Control axis No. of servo" to the 1st axis is the following.

Linear encoder resolution: 0.05 μ m

$$\text{Moving distance per one pulse (mm)} = \frac{0.05 \times 10^{-3} \text{ [mm]}}{1 \text{ [pulse]}} = \frac{1}{20000}$$

$$\frac{\text{AXGRTN}}{\text{AXGRTD}} \times \frac{1}{\text{AXENCN}} = \frac{1}{20000}$$

[Example of set value]

ACGRTN = 1

AXGRTD = 1

AXENCN = 20000

Therefore, the parameter set value is as follows.

AXGRTN = (1, 1, 1, 1, 1, 1, 1, 1, 1, 1, 1, 1, 1, 1, 1, 1) (Set the 1st element to 1.)

AXGRTD = (1, 10, 10, 10, 10, 10, 10, 10, 10, 10, 10, 10, 10, 10, 10, 10) (Set the 1st element to 1.)

AXENCN = (20000, 4194304, 4194304, 4194304, 4194304, 4194304, 4194304, 4194304, 4194304, 4194304, 4194304, 4194304, 4194304, 4194304, 4194304, 4194304) (Set the 1st element to 20000.)

(2) Speed related parameter (AXMREV/ AXJMX) setting

Set the rated speed and maximum speed as the parameter AXMREV (rated speed) and AXJMX (maximum speed)
(Unit: mm/s)

<Note>

When using the linear servo motor, set the set value of parameter AXUNT (unit system) to "2."
(Refer to "this manual/7.1.2 Details of parameters (4) AXUNT (unit system)")

[Example]

When the specification of linear servo motor which set the "Control-axis-No.-of-servo" to 1st axis are the following.

Rated speed 1800 (mm/s)

Maximum speed 2000 (mm/s)

AXMREV = (800, 2000, 2000, 2000, 2000, 2000, 2000, 2000, 2000, 2000, 2000, 2000, 2000, 2000, 2000, 2000, 2000, 2000, 2000)

AXJMX = (2000, 3000, 3000, 3000, 3000, 3000, 3000, 3000, 3000, 3000, 3000, 3000, 3000, 3000, 3000, 3000, 3000, 3000, 3000)



CAUTION

In MANUAL mode, the maximum speed of an additional axis is 10% of the value set in parameter AXJMX.

Therefore, when operating the robot mounted on a travel axis (additional axis) in MANUAL mode, set parameter AXJMX so that the operating speed (composite speed) of the robot including the travel axis does not exceed the safe speed (250 mm/s).

7.Setting, Operation and Command Explanation of Robot Additional Axis

7.2 Confirmation of connection

Before use, confirm the following items again.

Confirmation of connection

| No. | Confirmation item | Check |
|-----|----------------------------------------------------------------------------------------------------------------------------------------------------------|-------|
| 1 | Is the teaching pendant securely fixed? | |
| 2 | Is the exclusive communication cable properly connected between the controller and servo amplifier? (Refer to "Instruction Manual for Servo Amplifier".) | |
| 3 | Is the detector cable properly connected between the servo amplifier and motor? (Refer to "Instruction Manual for Servo Amplifier".) | |
| 4 | Is the servomotor power cable properly connected between the servo amplifier and motor? (Refer to "Instruction Manual for Servo Amplifier".) | |
| 5 | Is the ground wire properly connected between the servo amplifier and motor? (Refer to "Instruction Manual for Servo Amplifier".) | |
| 6 | Is the ground cable from the servo amplifier properly grounded? (Refer to "Instruction Manual for Servo Amplifier".) | |
| 7 | Is the brake unit properly connected? (Refer to "Instruction Manual for Servo Amplifier".) (When it is used,) | |
| 8 | Is the emergency stop circuit properly connected? (Refer to "Instruction Manual for Servo Amplifier".) (When it is used,) | |
| 9 | Are the parameters of the additional axis interface properly set? (Refer to "this manual/7.1Description of parameters".) | |
| 10 | Are the parameters of the servo amplifier properly set? (Refer to "Instruction Manual for Servo Amplifier".) | |
| 11 | Is the basic parameter PA03 ARS of the servo amplifier set to "0001"? (Refer to "Instruction Manual for Servo Amplifier".) | |
| 12 | Is the basic parameter PA14 POL of the servo amplifier set to "0"? (Refer to "Instruction Manual for Servo Amplifier".) | |
| 13 | Is the power supply of the controller turned OFF once after the parameters are set? | |
| 14 | Is the axis selection rotary switch (SW1) of the servo amplifier properly set? | |

After the preparation is completed, turn OFF the power supply of the additional axis system.

7.3 Try to use the robot additional axis

Regarding the robot additional axis, this chapter describes the basic operation from power turn-ON through operation to the end.

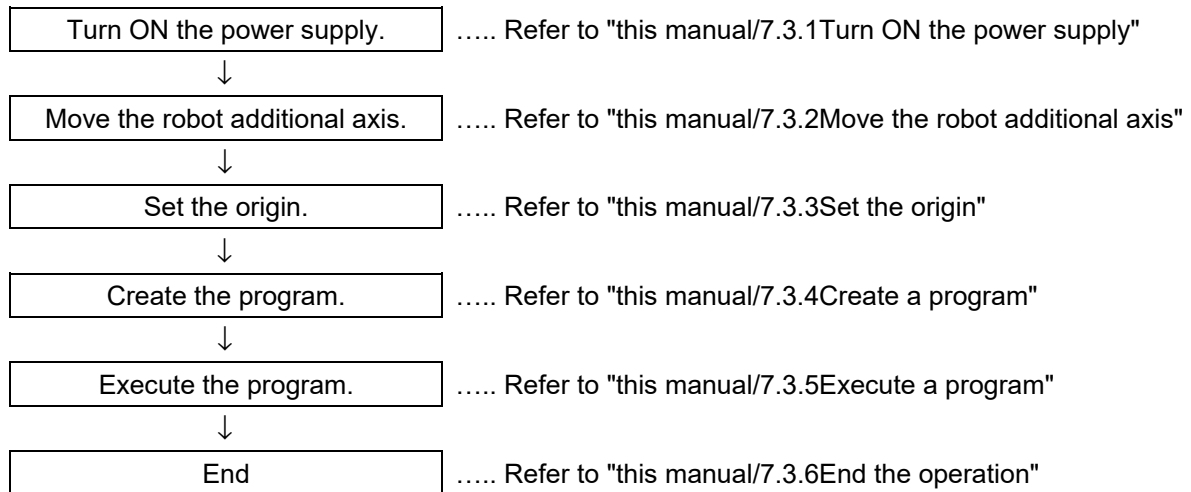

CAUTION

If any vibration occurs or any motion is not satisfied during operation of the additional axis, it is necessary to adjust (tune) the servo system. Referring to "Instruction Manual for Servo Amplifier and Servomotor", adjust it.



CAUTION

If the motor or absolute position detector has been replaced or the parameters related to mechanisms and axis structure have been changed, be sure to check the current position before performing any operation. If the origin position has been displaced, set the origin again. The above parameters are AXUNUM, AXMENO, AXJNO, AXUNT,AXSPOL and AXENCR.

7.3.1 Turn ON the power supply

Confirm the safety around the robot and additional axis and turn ON the power supply.

- (1) Turn ON the power supply of the servo system.
- (2) Turn ON the power supply of the controller.



CAUTION

Turn ON the power supply of the peripheral device earlier than the robot controller. If the power supply of the robot controller is turned ON earlier than the peripheral device, the robot controller may sometimes not recognize the peripheral device.

7.3.2 Move the robot additional axis

Move the axis by jog the additional axis of the teaching pendant.

- (1) Turn the "ENABLE/DISABLE" switch of the teaching pendant to "ENABLE".
- (2) Afterward, operate as follows.

7.Setting, Operation and Command Explanation of Robot Additional Axis

Table 7.3.1 Robot additional axis, jog operation

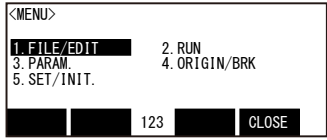
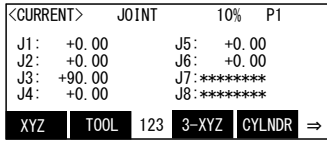
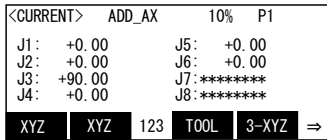
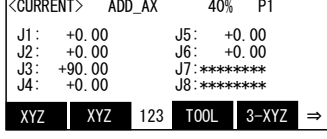
| NO | Teaching pendant screen display | Work details |
|----|-------------------------------------------------------------------------------------|----------------------------------------------------------------------------------------------------------------------------------------------------------------------------------------------------------------------------------------------------------------------------------------------------------------------------------------------------------------------------------|
| 1 |  | Pressing the Enable switch (3-position enable switch) on the rear of the teaching pendant, press [SERVO] key and turn ON the servo. Keeping the Enable switch (3-position enable switch) pressed, proceed with the following operation. If the Enable switch (3-position enable switch) is released on the way, the servo will be turned OFF. In this case, repeat this process. |
| 2 |  | Press the key of [JOG], then the jog operation screen will be displayed. Press the key of [FUNCTION], and display the "addition axis" at the screen lowest stage. And press the key of [F1], the jog mode turns into addition axis jog mode (3 screens). |
| 3 |  | [+X(J1)] key : The additional axis 1 moves in the + direction. [-X(J1)] key : The additional axis 1 moves in the - direction. [+Y(J2)] key : The additional axis 2 moves in the + direction. [-Y(J2)] key : The additional axis 2 moves in the - direction. Release the axis designation key, and the additional axis will stop. |
| 4 |  | [OVRD↑] key increases the jog speed. [OVRD↓] key decreases the jog speed. The percentage display of the speed is different depending on each model. |

Note 1) When the additional axis 2 is not used, it is not displayed on the screen of the teaching pendant.

Note 2) When the origin has been already set, the current position of the additional axis will be displayed in the "****" place.

7.3.3 Set the origin

For details of the actual origin setting, etc., refer to the origin setting in "Instruction Manual/ ROBOT ARM SETUP & MAINTENANCE". Here, the correspondence between the origin setting additional axis and the axis No. displayed in the origin setting screen is as follows.

| Origin setting axis | Origin setting screen display |
|---------------------|-------------------------------|
| Additional axis 1 | 7th axis |
| Additional axis 2 | 8th axis |



When setting the origin of the robot additional axis, don't carelessly set the origin of the robot arm. If it is wrongly set, input the origin data referring to the origin setting in "Instruction Manual/ ROBOT ARM SETUP & MAINTENANCE".

7.3.4 Create a program

As an example, a program to move the robot additional axis is created.

```
10 MOV P1
20 MOV P2
30 END
```

For the methods of the program input and position data registration, refer to the programming in "Instruction Manual/ Detailed explanations of functions and operations".

Moreover, for the registration method of the position variables of the robot additional axis, refer to "this manual/7.4.5Operation of position variable".

7.3.5 Execute a program

Try to execute a program created.

From the teaching pendant, confirm the operation in the step feed mode (For the step feed method, refer to Step feed in "INSTRUCTION MANUAL/Detailed explanations of functions and operations"). If any problem does not occur, execute the program in the OPERATION screen of the teaching pendant.

- (1) Press the [ENABLE] button of the teaching pendant to disable the teaching pendant.
- (2) Select "OPERATION" in the "RUN" screen of the teaching pendant to display the OPERATION screen.
- (3) Press the function key [F4] to which "CHOOSE" in the OPERATION screen has been assigned to display the Select robot program screen.
- (4) Enter the name of the program to be executed and press the [EXE] key.
- (5) When the servo is OFF, press the function key [F1] to which "SVO ON" in the "OPERATION" screen has been assigned to turn ON the servo.
- (6) Press the function key [F1] to which "START" in the OPERATION screen has been assigned to execute the program.

For details of the operation procedure, refer to Starting automatic operation in "INSTRUCTION MANUAL/Detailed explanations of functions and operations".

7.3.6 End the operation

Confirm that the program is interrupted or stopped, proceed with the following operation and turn OFF the power supply of the additional axis system.

- (1) Turn the mode switch of the teaching pendant to "DISABLE".
- (2) Select "OPERATION" in the "RUN" screen of the teaching pendant to display the OPERATION screen.
- (3) Press the function key [F2] to which "SVO OFF" in the OPERATION screen has been assigned to turn OFF the robot and the servo of the additional axis.
- (4) Turn OFF the power supply of the controller.
- (5) Turn OFF the power supply of the servo system.

Though an alarm occurs on the servo system side during operation of (4) to (5), continue the operation and shut down the power supply of the servo system, and any problem will not occur.

7.Setting, Operation and Command Explanation of Robot Additional Axis

7.4 Operation of the Robot's Additional Axis

This section describes the procedures for operating the additional axis interface for each of the operating functions.



CAUTION

If any vibration occurs or any motion is not satisfied during operation of the additional axis, it is necessary to adjust (tune) the servo system. Referring to "Instruction Manual for Servo Amplifier and Servomotor", adjust it.

7.4.1 Brake release

The brake of the robot additional axis can not be released from the robot controller. To release the brake, refer to "Instruction Manual for Servo System".

7.4.2 Origin setting

The origin of the robot additional axis is set with the same operation as that of the standard system. For details of the actual origin setting, etc., refer to the origin setting in "Instruction Manual/ ROBOT ARM SETUP & MAINTENANCE". In case of the robot additional axis, the correspondence between the additional axis of the origin setting and the axis number displayed on the origin setting screen is as follows.

| Origin setting axis | Origin setting screen display |
|---------------------|-------------------------------|
| Additional axis 1 | 7th axis |
| Additional axis 2 | 8th axis |



CAUTION

When setting the origin of the robot additional axis, don't carelessly set the origin of the robot arm. If it is wrongly set, input the origin data referring to the origin setting in "Instruction Manual/ ROBOT ARM SETUP & MAINTENANCE".

7.4.3 Servo ON/OFF

[Function]

The servo of the robot additional axis is turned ON/OFF.

The servo of the additional axis is linked with the servo power supply of the robot arm.

The operating method is the same as that of the standard system. For details of the actual servo ON method, refer to the Turning the servo ON/OFF of "Instruction Manual/ Detailed explanations of functions and operations".

7.4.4 Jog operation

[Function]

The robot additional axis is moved.

The screen and content displayed for this operation are as follows. Here, the unit of the additional axis displayed is set with the parameter (AXUNT) (Angle: degree or Length: mm). For the parameter setting method, refer to "this manual/7.1Description of parameters".

| <CURRENT> | ADD_AX | 100% | M1 | T00 | B* |
|-----------|--------|------|--------|-------|----|
| J1: | 0.00 | J5: | -90.00 | | |
| J2: | 0.00 | J6: | 180.00 | | |
| J3: | 90.00 | J7: | 0.00 | | |
| J4: | 0.00 | J8: | 0.00 | | |
| XYZ | XYZ | JOG | TOOL | 3-XYZ | ⇒ |

→ Display of current jog mode and jog speed

→ Display (additional axis 1) of current position

→ Display (additional axis 2) of current position

Note) Additional axes that are not present are displayed as shown below.

When the additional axis 2 is not present

| <CURRENT> | ADD_AX | 100% | M1 | T00 | B* |
|-----------|--------|------|--------|-------|----|
| J1: | 0.00 | J5: | -90.00 | | |
| J2: | 0.00 | J6: | 180.00 | | |
| J3: | 90.00 | J7: | 0.00 | | |
| J4: | 0.00 | : | | | |
| XYZ | XYZ | JOG | TOOL | 3-XYZ | ⇒ |

When the additional axis 1 is not present

| <CURRENT> | ADD_AX | 100% | M1 | T00 | B* |
|-----------|--------|------|--------|-------|----|
| J1: | 0.00 | J5: | -90.00 | | |
| J2: | 0.00 | J6: | 180.00 | | |
| J3: | 90.00 | J7: | **** | | |
| J4: | 0.00 | J8: | 0.00 | | |
| XYZ | XYZ | JOG | TOOL | 3-XYZ | ⇒ |

[Method]

The additional axis is moved by the jog operation of the teaching pendant. For details, refer to "this manual/7.3.2 Move the robot additional axis".

[Explanation]

- (1) The moving speed can be switched by pressing [OVRD (upper arrow)] (jog speed UP) or [OVRD(lower arrow)] (jog speed DOWN). For details, refer to the jog feed in "Instruction Manual/ Detailed explanations of functions and operations".
- (2) If any motion range or speed limit may be exceeded, the robot will stop with an error.
- (3) Before the origin is set, "****" is displayed at the current position data of the additional axis of the teaching pendant.



In another jog operation except the additional axis jog mode, the robot arm and mechanical additional axis move and the robot additional axis does not move.

7.Setting, Operation and Command Explanation of Robot Additional Axis

7.4.5 Operation of position variable

The position variable (position No.) can be operated using the teaching pendant like the standard system.

[Function]

The current position is registered at the position variable (position No.).
The current position of the additional axis is registered at the same time.

[Method]

Press [F2](Teach)key, and [F1] (Yes) key of confirmation screen.
For details, refer to "Instruction Manual/ Detailed explanations of functions and operations".

7.Setting, Operation and Command Explanation of Robot Additional Axis

7.4.6 MDI (Manual Data Input) compensation of robot additional axis

[Function]

The registered position data is compensated by operating the key.
The screen which displays the data of the additional axis is added.
The screen and content displayed by this operation are as follows.

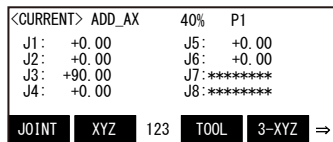

→ Position No. which registers the position

→The coordinate value to register

Fig. 7.4.1 MO position screen

[Method]

A case to change the additional axis 1 of the position variable P3 from +20.00 to +50.00 is described as follows.

Table 7.4.1 MDI compensation operation

| NO | Teaching pendant screen | Work details |
|----|-------------------------|----------------------------------------------------------------------------------------------------------------------------------------------------------------------------------------------------------------------------------------------|
| 1 | | <p>Press the function key corresponding to "Cange"after selecting the line which used P2 of position variable, display the position edit screen.</p> <p>The P2 of position variable is called and display the current registration data.</p> |
| 2 | | <p>Press the [↓] key three times, move cusor to additional axis 1.</p> |
| 3 | | <p>Long press the [CLEAR] key, and delete additional axis 1.</p> |
| 4 | | <p>Press the [5], [0], [EXE] key. Additional axis 1 is set to "+50".</p> |

[Explanation]

- (1) The cursor can be moved with [arrow] keys.
- (2) If it is improperly input, press [CLEAR] to delete the character.

7.4.7 Operation

The operation is started like the standard system. For details of the actual operation starting method, etc., refer to separate "Instruction Manual/ Detailed explanations of functions and operations".

7.Setting, Operation and Command Explanation of Robot Additional Axis



Regardless of the type of the interpolation command, the robot additional axis moves from the start point to the end point in the joint interpolation mode. The start and end of the operation of the robot additional axis is simultaneous with the start and end of the operation of the main unit (simultaneous interpolation).



If any program execution is interrupted and the additional axis is moved with the jog or servo OFF, it will return to the interrupted position for motion when the program is restarted.

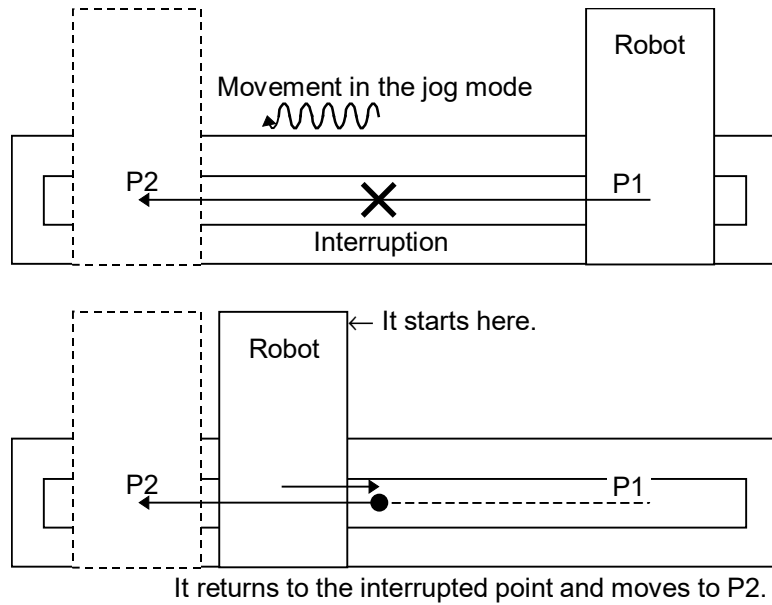

Fig. 7.4.2 Motion when the interruption of the robot additional axis is restarted

7.4.8 Stop

- Stop

The program in running is stopped, and the robot arm and robot additional axis in moving is decelerated and stopped. In this stop mode, the servo is kept ON and the brake is not activated. The stop is operated like the standard system. For details of the actual stop method, refer to the stop in "Instruction Manual/ Detailed explanations of functions and operations".

7.Setting, Operation and Command Explanation of Robot Additional Axis

- Emergency stop

The servo is turned OFF, the brake is activated and the robot arm and robot additional axis are immediately stopped. This is called the emergency stop. There are three emergency stop methods as follows.

- (1) Press [EMG.STOP] key of the teaching pendant.
- (2) Emergency stop with the external emergency stop terminal on the rear of the robot controller.
- (3) Emergency stop with the emergency stop circuit attached to the servo system.

Among them, Items (1) and (2) are carried out like the standard system. For details of the actual emergency stop method, etc., refer to the connecting the external emergency stop in "Instruction Manual/ Controller setup, basic operation, and maintenance".

For the using method and others of Item (3), refer to "Instruction Manual for Servo System" purchased.

7.4.9 Error resetting

The error resetting is carried out like the standard system. For details of the actual error resetting method, refer to the error reset operation in "Instruction Manual/ Detailed explanations of functions and operations".

7. Setting, Operation and Command Explanation of Robot Additional Axis

7.5 Explanation of commands

The applied commands are the same as those of the standard system. However, there are some added points about the describing method of the position variables.

7.5.1 Interpolation commands

During execution of the interpolation command, the robot additional axis moves in the speed pattern (acceleration/deceleration motion) like "Fig. 7.5.1 Moving speed of additional axis" from the start point to the end point in all other modes except the circular interpolation, and the start/end of the interpolation is simultaneous with those of the robot arm. (Simultaneous interpolation)

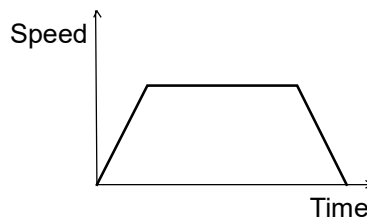

Fig. 7.5.1 Moving speed of additional axis

As the motions of the additional axis are summarized regarding the interpolation commands, they become as shown in "Table 7.5.1 Robot additional axis motion during each interpolation "

Table 7.5.1 Robot additional axis motion during each interpolation

| Interpolation method | Motion of robot additional axis | |
|------------------------------------------|----------------------------------------------------------------------------------------------------------------------------------------------------------------------------------------------------------------------------------------------------------------------------------------------------------------------------------------------------------------------------------------------------------------------------------------------------------------------------------------------------------------------------------------------------------------------------------------------------------------------------------------------------------------------------------------------------------------------------------------------------------------------------------------------------------------------------------------------|--|
| Joint interpolation (Mov) | Simultaneous interpolation by acceleration/deceleration motion from start point to end point | |
| Linear interpolation (Mvs) | Simultaneous interpolation by acceleration/deceleration motion from start point to end point | |
| Circular interpolation (Mvr, Mvr2, Mvr3) | <p>Simultaneous interpolation by acceleration/deceleration operation from start point to end point. At the transit point, center point and reference point except the start point and end point, the registered points of the robot additional axis are ignored. Moreover, the linear interpolation to the start point of the circular interpolation is simultaneously done with the acceleration/ deceleration motion. Mvr, Mvr2 and Mvr3 are all processed under "Linear interpolation to P1 → Circular interpolation from P1 to P3" and the additional axis data of P2 is ignored. (Refer to the right figure.)</p> <p>Moreover, refer to "this manual/7.5.2 Synchronous control of robot additional axis (travel axis)" when it is desired to produce an accurate circle by simultaneously moving the robot arm and additional axis.</p> | |
| Circle interpolation (Mvc) | <p>During circle interpolation, the additional axis does not move. However, the linear interpolation to the start point of the circle interpolation is simultaneous with the acceleration/deceleration motion. Mvc are processed under "Linear interpolation to P1 → Circle interpolation of the robot only without movement of the robot additional axis", and the additional axis data of P2 and P3 is ignored.</p> | |

7.Setting, Operation and Command Explanation of Robot Additional Axis

| Interpolation method | Motion of robot additional axis |
|------------------------------------|-------------------------------------------------------------------------------------------------------------------------------------------------------------------------------------------------------------------------------------------------------------------------------------------------------------------------|
| Spline interpolation (MvSpl) | The spline interpolation and Ex-T spline interpolation do not target additional axes. Even if the coordinate value of the additional axis have been set at each path point, the additional axis does not move from the coordinate value at the starting point during spline interpolation or Ex-T spline interpolation. |
| Ex-T spline interpolation (EMvSpl) | However, when the current position of the additional axis differs from the coordinate value at the starting point, the additional axis moves to the starting point. |



Between the interpolation motion of the robot arm and the interpolation motion of the robot additional axis, there is not any other relationship excluding that the start and end of each interpolation are at the same time. Accordingly, if it is used as the travel axis which moves with the robot loaded, the locus of the control point is not assured in the circular interpolation and linear interpolation.

7.5.2 Synchronous control of robot additional axis (travel axis)

If any circular interpolation in which the additional axis position also varies is applied for the robot additional axis, the robot arm will draw an arc and the robot additional axis will be simultaneously accelerated/decelerated. Therefore, the tool tip will not draw any accurate circle but a locus, which is approximate to an ellipse. (Refer to "this manual/7.5.1 Interpolation commands.) If any circular interpolation is applied with the additional axis moved, the synchronous control will be used. Since the robot additional axis and the robot arm move in synchronization with each other due to the synchronous control, the tool tip of the robot can draw an accurate arc. Moreover, the speed of the circular/linear interpolation including the travel axis can be also designated by SPD command. This function is applicable only to the linear drive axis, which moves with the robot loaded like the travel axis. The valid commands are as follows.

- (1) Various circular interpolations (However, the circle interpolation is excluded.)
- (2) Linear interpolation
- (3) Circular pallet

However, this control can not be used on the 5-axis robots.

7.Setting, Operation and Command Explanation of Robot Additional Axis

The examples of the circular interpolation and circular pallet are described as follows.

[Example] Circular interpolation

In case of the circular interpolation, the additional axis and robot arm synchronously moves to draw an arc. The applicable commands are shown in "Table 3.5.3 Applicable commands".

Table 7.5.3 Applicable commands

| Language method | Applicable commands |
|-------------------------------|------------------------------------------------------------------------------------------------|
| MELFA-BASICVI MELFA-BASICV | Mvr, Mvr2, Mvr3, Mvs (Mvc is not applicable since the start point and end point are the same.) |

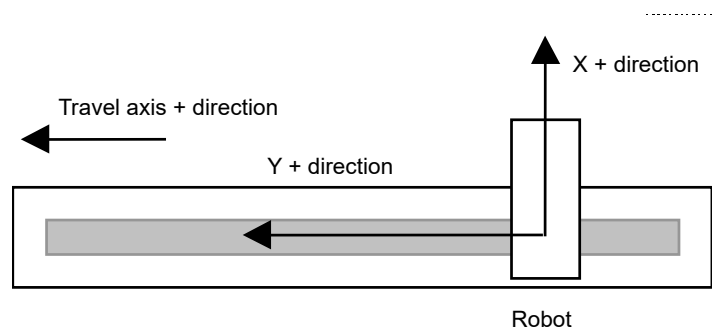

Fig. 7.5.2 Example of circular interpolation

If any circular interpolation is executed in the configuration (travel axis is 8th axis) as shown in "Fig. 7.5.2 Example of circular interpolation",

- 1 P1 = (200, 500, 400, 0, 0, 0, 0, 1000) (7, 0)
- 2 P2 = (200, 300, 800, 0, 0, 0, 0, 800) (7, 0)
- 3 P3 = (200, 100, 400, 0, 0, 0, 0, 600) (7, 0)
- 4 Mvr P1, P2, P3
- 5 End

Move in a semicircle with a radius of 400mm at the posture center of (200, 300, 400, 0, 0, 0, 0, 800).

7.Setting, Operation and Command Explanation of Robot Additional Axis

[Example] Circular pallet

When the circular pallet function is used, the position data on the calculated circular pallet becomes the data for which the position of the additional axis is taken into consideration as shown with the following example.

Def Plt 1, P1, P2, P3, , 7, 1, 3

Plt 1,1 = (200,500,400,0,0,0,0,1000)

Plt 1,2 = (200,300+200*sqrt(3)/2 ,600,0,0,0,0,800+200*sqrt(3)/2)

Plt 1,3 = (200,400,400+400*sqrt(3)/2 ,0,0,0,0,900)

Plt 1,4 = (200,300,800,0,0,0,0,800)

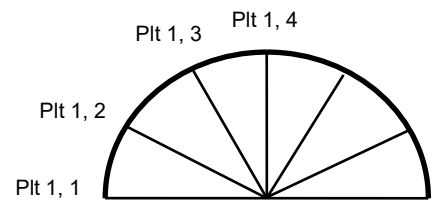

In order to make this function valid, it is necessary to set "Table 7.5.4 Parameter list of synchronous control".

Table 7.5.4 Parameter list of synchronous control

| Parameter name | Content | Range of settable value | Default value | Explanation |
|----------------|------------------------------------------|-------------------------|---------------|------------------------------------------------------------------------------------------------------------------------------------------------------------------------------------------------------------------------------------------------------------------------------|
| AXSYNC | Additional axis synchronous control axis | 0, 7, 8 | 0 | Among the robot additional axes, the synchronous control axis is set. If any other axis except 7th and 8th axes is set, the function becomes invalid. |
| AXDIR | Synchronous direction of additional axis | Real number | 0.0, 0.0, 0.0 | Conversion from the coordinate system in which the travel axis + direction is used as X axis to the robot coordinate. From the 1st element, it is shown around X axis, Y axis and Z axis. As the default value, the robot X + direction matches the travel axis + direction. |

[Example]

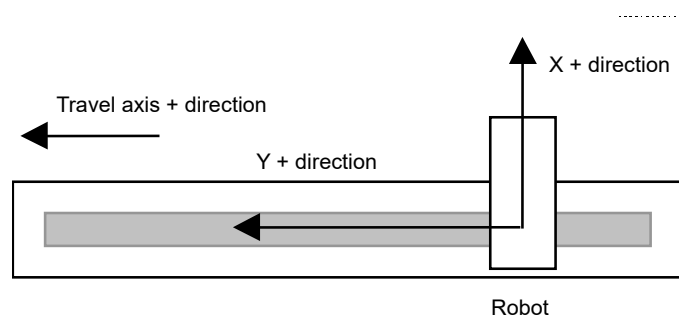

Fig. 7.5.3 Robot X axis direction and travel axis + direction

The parameter AXDIR is "0.0, 0.0, -90.0" in the case shown above.

7.Setting, Operation and Command Explanation of Robot Additional Axis

7.5.3 Position variables

- (1) The position of the robot additional axis is designated as follows.

[Example]

A value including the position of the additional axis to the position variable P1 is substituted at the program line No. 1 as described below.

1 P1 = (100, 50, 300, 180, 0, 180, 500, -300) (7, 0)

Additional axis 1 (7th axis)

Additional axis 2 (8th axis)

- (2) The element data of the robot additional axis is expressed with the value as shown below.

Additional axis 1 (7th axis) L1

Additional axis 2 (8th axis) L2

[Example]

At the program line No. 2, the value of the position of the additional axis 1 of the position variable P3 is changed as described below.

2 P3. L1 = 50 (500mm if the additional axis 1 is a direct moving axis) or
 2 P3. L1 = Rad (50) (50deg if the additional axis 1 is a rotation axis)

- (3) The result of the calculation related to the position variable of the additional axis is as follows.

| | |
|-------------------------------------------|--------------------------------------------------------------------------|
| Position variable + (-) Position variable | The element data of the additional axis is also calculated as it is. |
| Position variable × Position variable | The element data of the additional axis is processed in the addition. |
| Position variable ÷ Position variable | The element data of the additional axis is processed in the subtraction. |
| Value variable × (÷) Position variable | The element data of the additional axis is processed as it is. |

- (4) The element data of the additional axis of the grid point position of the pallet is calculated like the robot.

7.6 Example of System Configuration of the Robot's Additional Axis

This section shows an example of system configuration using the additional axis interface.

7.6.1 Travel axis system

- System Overview

The following shows an example when the travel axis is used as a robot's additional axis in a system where a standard robot is placed on the travel axis.

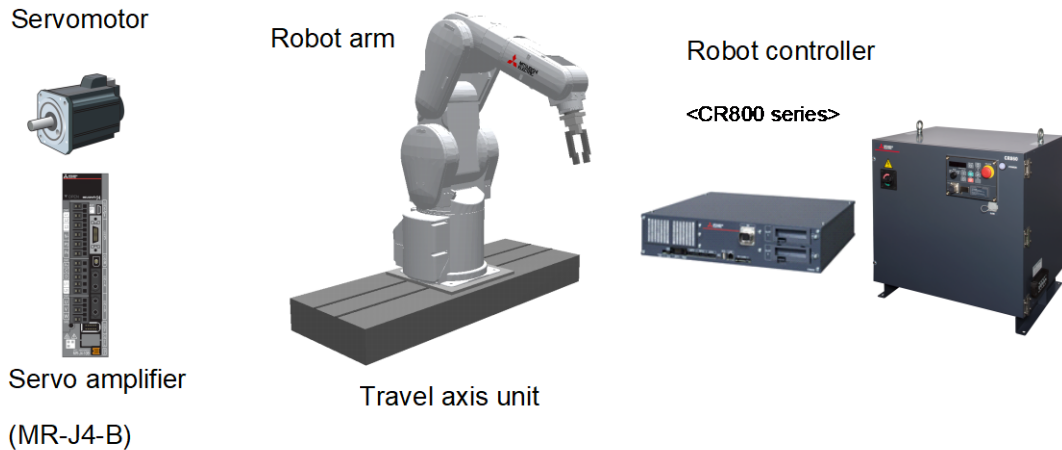

Note) The fig of the robot arm is the vertical multi-joint type 6 axis robot's example.

Fig. 7.6.1 Travel axis system (an example)

Table 7.6.1 Structural equipment

| | |
|------------------|---------------------------------------|
| Robot arm | Vertical 6-axis robot |
| Robot controller | CR800 series controller |
| Servo amplifier | Prepared by the customer. |
| Servo motor | Prepared by the customer. |
| Travel axis unit | Manufactured and prepared by customer |

Table 7.6.2 Travel axis specification

| | |
|--------------------------------------------------|---------------------------------------------------------------------------|
| Control axis number of servo | 1st |
| Axis number of robot | Additional axis1(7th axis) |
| Unit of additional axis | mm (Direct moving axis) |
| Rotation direction of additional axis | Forward run (CCW) |
| Acceleration/deceleration of the additional axis | 0.4 seconds per each |
| Total speed ratio of additional axis | 37/2 (Robot's additional axis displacement of 37/2 mm per motor rotation) |
| Rated speed | 3000 (rpm) |
| Maximum speed | 4000 (rpm) |
| Encoder resolution | 4194304 (pulse/rev) |
| Operating range | -2000~+3000 (mm) |
| Origin designated by user | 0mm (same as the default value) |

7. Setting, Operation and Command Explanation of Robot Additional Axis

- Connecting devices

Devices are connected as follows.

- (1) Connect servo amplifier (CN1A connector) with the robot controller by the SSCNETIII cable. Connect the robot controller with the AXIS connector. (Refer to "5.1 Connection of Robot CPU and servo amplifier" in this manual.)
- (2) Set the axis selection rotary switch (SW1) of the servo amplifier to "0". (Refer to "6.1 Servo amplifier setting" in this manual.)
- (3) Connect the servo amplifier and the servo motor.

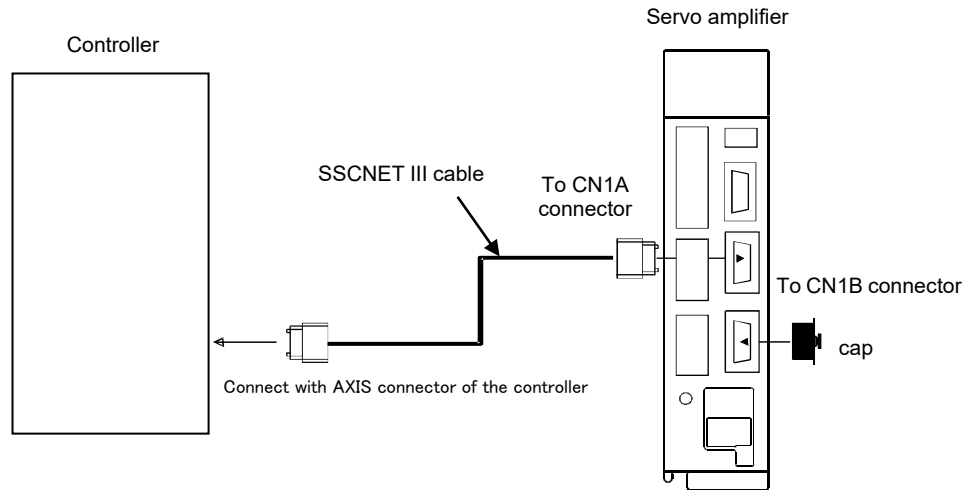

Fig. 7.6.2 Connection of controller and servo amplifier

CAUTION

Please install the connector cap to the connector for communication which does not connect the SSCNETIII cable. There is a possibility of malfunctioning if the cap is not installed. And, if the light from the connector for communication hits upon the eyes, there is a possibility of feeling the incompatibility for the eyes.

- Setting the servo amplifier parameters

Set the servo amplifier parameters by refer to "6.2 Parameter setting of servo amplifier."

7.Setting, Operation and Command Explanation of Robot Additional Axis

- Setting the robot controller parameters

Set the parameters related to the system configuration of the robot controller.
For details on how to set these parameters, refer to separate "Instruction Manual/ Detailed explanations of functions and operations".

Table 7.6.3 Setting the travel axis system parameters

| Parameter name changed | Before/after change | Value of parameter |
|-----------------------------|---------------------|----------------------------------------------------------------------------------------------------------------------------------------------------------------------|
| AXUNUM | Before | 0 |
| | After | 0 |
| AXMENO | Before | 0, 0, 0, 0, 0, 0, 0, 0, 0, 0, 0, 0, 0, 0, 0, 0 |
| | After | <u>1</u> , 0, 0, 0, 0, 0, 0, 0, 0, 0, 0, 0, 0, 0, 0, 0 |
| AXJNO | Before | 0, 0, 0, 0, 0, 0, 0, 0, 0, 0, 0, 0, 0, 0, 0, 0 |
| | After | <u>7</u> , 0, 0, 0, 0, 0, 0, 0, 0, 0, 0, 0, 0, 0, 0, 0 |
| AXUNT | Before | 0, 0, 0, 0, 0, 0, 0, 0, 0, 0, 0, 0, 0, 0, 0, 0 |
| | After | <u>1</u> , 0, 0, 0, 0, 0, 0, 0, 0, 0, 0, 0, 0, 0, 0, 0 |
| AXSPOL | Before | 0, 0, 0, 0, 0, 0, 0, 0, 0, 0, 0, 0, 0, 0, 0, 0 |
| | After | 0, 0, 0, 0, 0, 0, 0, 0, 0, 0, 0, 0, 0, 0, 0, 0 |
| AXACC | Before | 0.20, 0.20, 0.20, 0.20, 0.20, 0.20, 0.20, 0.20, 0.20, 0.20, 0.20, 0.20, 0.20, 0.20, 0.20, 0.20 |
| | After | <u>0.40</u> , 0.20, 0.20, 0.20, 0.20, 0.20, 0.20, 0.20, 0.20, 0.20, 0.20, 0.20, 0.20, 0.20, 0.20, 0.20 |
| AXDEC | Before | 0.20, 0.20, 0.20, 0.20, 0.20, 0.20, 0.20, 0.20, 0.20, 0.20, 0.20, 0.20, 0.20, 0.20, 0.20, 0.20 |
| | After | <u>0.40</u> , 0.20, 0.20, 0.20, 0.20, 0.20, 0.20, 0.20, 0.20, 0.20, 0.20, 0.20, 0.20, 0.20, 0.20, 0.20 |
| AXGRTN | Before | 1, 1, 1, 1, 1, 1, 1, 1, 1, 1, 1, 1, 1, 1, 1, 1 |
| | After | <u>37</u> , 1, 1, 1, 1, 1, 1, 1, 1, 1, 1, 1, 1, 1, 1, 1 |
| AXGRTD | Before | 10, 10, 10, 10, 10, 10, 10, 10, 10, 10, 10, 10, 10, 10, 10, 10 |
| | After | <u>2</u> , 10, 10, 10, 10, 10, 10, 10, 10, 10, 10, 10, 10, 10, 10, 10 |
| AXMREV | Before | 2000, 2000, 2000, 2000, 2000, 2000, 2000, 2000, 2000, 2000, 2000, 2000, 2000, 2000, 2000, 2000 |
| | After | <u>3000</u> , 2000, 2000, 2000, 2000, 2000, 2000, 2000, 2000, 2000, 2000, 2000, 2000, 2000, 2000, 2000 |
| AXJMX | Before | 3000, 3000, 3000, 3000, 3000, 3000, 3000, 3000, 3000, 3000, 3000, 3000, 3000, 3000, 3000, 3000 |
| | After | <u>4000</u> , 3000, 3000, 3000, 3000, 3000, 3000, 3000, 3000, 3000, 3000, 3000, 3000, 3000, 3000, 3000 |
| AXENCR | Before | 4194304, 4194304, 4194304, 4194304, 4194304, 4194304, 4194304, 4194304, 4194304, 4194304, 4194304, 4194304, 4194304, 4194304, 4194304, 4194304 |
| | After | 4194304, 4194304, 4194304, 4194304, 4194304, 4194304, 4194304, 4194304, 4194304, 4194304, 4194304, 4194304, 4194304, 4194304, 4194304, 4194304 |
| MEJAR (Mechanism No.1) | Before | -?, ?, -?, ?, -?, ?, -?, ?, -?, ?, -?, ?, -80000.00, 80000.00, -80000.00, 80000.00 |
| | After | -?, ?, -?, ?, -?, ?, -?, ?, -?, ?, -?, ?, -2000.00, 3000.00, -80000.00, 80000.00 (Use a value that has previously been registered for the part indicated by "?".) |
| USERORG (Mechanism No.1) | Before | ?, ?, ?, ?, ?, ?, 0.0, 0.0 |
| | After | ?, ?, ?, ?, ?, ?, 0.0, 0.0 |

7. Setting, Operation and Command Explanation of Robot Additional Axis

• Program example

(1) Details of work

The operation of this system consists of a standard robot unloading a work from station A (position "<1>") and transporting the work to station B (position "<2>").

In station B, the time required for teaching will be saved by using the pallet function.

To use the pallet function, it is necessary to enable synchronous control of the robot's additional axis, however.

(For details on synchronous control, refer to "7.5.2 Synchronous control of robot additional axis (travel axis).")

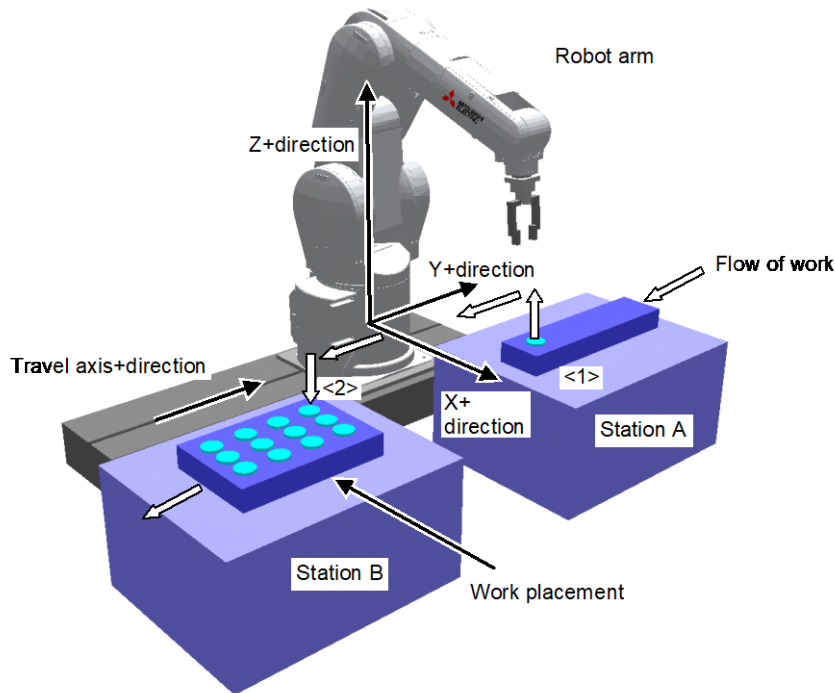

• Flow of work

- (i) A work is transported to station A from the external location.
- (ii) When the work is transported, the robot unloads the work from station A, and palletizes the work onto the work placement table of station B.
- (iii) When the work placement table of station B becomes full, the works will be transported to the external location.

(2) Robot Program Structure

Prepare one robot program as shown below

| Program name | Explanation |
|--------------|--------------------------------------|
| 1 | Operation program of standard robots |

7. Setting, Operation and Command Explanation of Robot Additional Axis

(3) Input/Output signal

The general I/O signals to be used are as follows

| General purpose input/output name | Signal H/L | Explanation |
|-----------------------------------|------------|-------------------------------------------------------------------------------|
| General purpose input 10080 | H (1) | Transport of works from the external location to station A has been complete. |
| | L (0) | No work in station A |

| General purpose input/output name | Signal H/L | Explanation |
|-----------------------------------|------------|---------------------------------------------------------|
| General purpose output 10080 | H (1) | Works are full in station B (work table change request) |
| | L (0) | Transporting a work to station B |

(4) Position variable

The position data is as follows

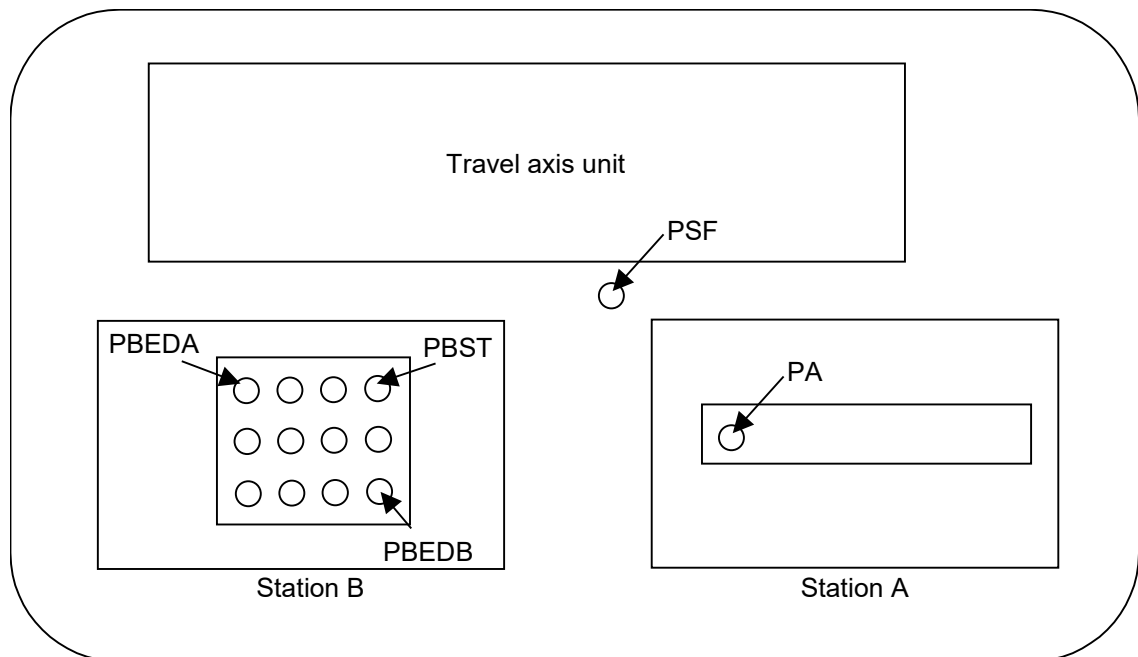

| Mechanism name | Position variable name | Explanation |
|----------------|------------------------|-------------------------------------------------------------------------|
| Robot arm | PSF | Safe position |
| | PA | Position where works are unloaded from station A |
| | PBST | Position where works are loaded to station B (Start position of pallet) |
| | PBEDA | Position where works are loaded to station B (End-A position of pallet) |
| | PBEDB | Position where works are loaded to station B (End-B position of pallet) |

7.Setting, Operation and Command Explanation of Robot Additional Axis

(5) Procedure up to program execution

Procedure 1 : Program creation

<1>Program of mechanism number 1 (Program name:1)

| | |
|-------------------------------------|-------------------------------------------------------------------|
| 1 Def Plt 1,PBST,PBEDA,PBEDB,,4,3,2 | ' Definition of palette number 1 |
| 2 Mov PSF | ' Move to safe position |
| 3 HOpen 1 | ' Open the hand1 |
| 4 M1=1 | ' M1 is used for counter |
| 5 *W1 | |
| 6 If M_In(11)=0 Then GoTo *W1 | ' Waits for the transport of a work |
| 7 M_Out(11)=0 | ' Transporting a work |
| 8 *LOOP | |
| 9 Mov PA,-50 | ' Moves to the position of 50 mm back from work unloaded position |
| 10 Mvs PA | ' Moves to the position where work is unloaded |
| 11 HClose 1 | ' Close the hand1 |
| 12 Dly 0.5 | ' Waits for 0.5 sec |
| 13 Mvs PA,-50 | ' Moves to the position of 50 mm back from work unloaded position |
| 14 PB=(Plt 1,M1) | ' Calculates the position in the pallet number 1 indicated by M1 |
| 15 Mov PB,-50 | ' Moves to the position 50 mm back from the work placing position |
| 16 Mvs PB | ' Moves to the work placing position |
| 17 HOpen 1 | ' Open the hand1 |
| 18 Dly 0.5 | ' Waits for 0.5 sec |
| 19 Mvs PB,-50 | ' Moves to the position 50 mm back from the work placing position |
| 20 M1=M1+1 | ' Advances the counter |
| 21 If M1<=12 Then *LOOP | ' Loops as many as the number of works |
| 22 M_Out(11)=1 | ' Work full |
| 23 End | |

Procedure 2 : Setting synchronous control of the robot's addition axis

Set the parameters as shown below.

For more details, refer to "7.5.2Synchronous control of robot additional axis (travel axis)."

| Parameter | Default value | Setting value |
|-----------|---------------|-----------------|
| AXSYNC | 0 | 7 |
| AXDIR | 0.0, 0.0, 0.0 | 0.0, 0.0, -90.0 |

Procedure 3 : Reflecting the parameters

Turn off the power to enable the AXSYNC and AXDIR parameters, and then turn on the power again.

Procedure 4 : Starting

Run the program 1 in the OPERATION screen of the teaching pendant.

8. User Mechanism Settings, Operation, and Commands

When the additional axis is used as a multi-mechanism (controlled asynchronously with the robot arm), each axis of the mechanism is called a user mechanism.

This section describes a series of operating procedures including parameter settings, activating and quitting the user mechanism, as well as the commands that have been added and changed.

8.1 Procedure for Setting the Parameters of the User Mechanism

To use the additional axis as a multi-mechanism (user mechanism), perform setup according to the procedures below

- (1) Set the parameters shown in "Table 8.2.1 Parameter List."
However, MEJAR (Joint Movement Range) and USERORG (User-Designated Origin) are set in Procedure 4, so they are not set here.
- (2) Turn off the power once and then turn it on again. Check that error H7613 ("Turn the power off and on once") occurs. However, this error occurs only when the number of mechanisms is increased.
- (3) If error H7613 occurs, turn off the power once and then turn it on again.
- (4) On the parameter setting screen for the target mechanism, set MEJAR (Joint Movement Range) and USERORG (User-Designated Origin).
- (5) Set the servo system parameters with the servo amplifier's option, "Servo Support Software". Refer to "6.2 Parameter setting of servo amplifier". For setup method and values of the servo system program, refer to the Servo Amplifier Instruction Manual.

8.2 Description of parameters

Before use, it is necessary to surely set the following parameters. The parameters set at the robot controller are shown in "Table 8.2.1 Parameter list". For the method to set the parameters, refer to "Instruction Manual/ Detailed explanations of functions and operations".



After changing the parameters, turn the power supply of the controller from OFF to ON. Unless this is done, the changed parameters will not become valid.



If any motor, absolute position detector, etc., is replaced or any parameter related to the mechanism and the axis configuration is changed, be sure to confirm the current position. If the origin is dislocated, set the origin again. The parameters related to the axis configuration are the multi mechanism applied quantity (AXUNUM), mechanism No. designation (AXMENO), setting axis No. (AXJNT), unit system (AXUNT), rotation direction (AXSPOL) and endoder resolution (AXENCR).



Because to prevent the collision to peripheral equipment, the mechanical stopper, etc., sure set up the operating range (MEJAR) before moving the additional axis.

8. User Mechanism Settings, Operation, and Commands

8.2.1 Parameter list

The parameters are listed in the following "Table 8.2.1 Parameter list". For details of the parameters, refer to "this manual/8.2.2 Details of parameters".

Table 8.2.1 Parameter list

| Parameter name | Content | Settable range | Number of elements | Number of elements per axis | Default value | Explanation |
|----------------|---------------------------------|-------------------------------------------|--------------------|-------------------------------|-------------------|-------------------------------------------------------------------------------------------------------------------------------------------------------------------------------------------------------|
| AXUNUM | Number of multi mechanisms used | 0 to 2 | 1 | – | 0 | The number of multi-mechanism to use. (The robot and the mechanism of mechanism number 1 are exclude.) |
| AXMENO | Mechanism No. designation | 0 to 3 | 16 | 1 (per control axis of servo) | 0 | Input the mechanism No. to the element which corresponds to the servo control axis No. used and be sure to set "0" for the axis not used. |
| AXJNO | Setting axis No. | 0 to 8 | 16 | 1 (Same as above) | 0 | Designate what number of the axis of the robot arm is used for the additional axis. |
| AXUNT | Unit system | 0 or 1 | 16 | 1 (Same as above) | 0 | Unit system of additional axis 0 ... Angle (degree) 1 ... Length (mm) 2 ... Length (mm) Linear servo use (Set up "2", when using the linear servo) |
| AXSPOL | Rotation direction | 0 or 1 | 16 | 1 (Same as above) | 0 | Set the rotation direction of the motor. 1 ... Forward run (CCW) 0 ... Reverse run (CW) Be sure to set "0" (CCW) at the "POL" parameter of the basic parameter No. 7 of the servo amplifier. |
| AXACC | Acceleration time | Positive real number | 16 | 1 (Same as above) | 0.20 | Acceleration time (Unit: second) of additional axis |
| AXDEC | Deceleration time | Positive real number | 16 | 1 (Same as above) | 0.20 | Deceleration time (Unit: second) of additional axis |
| AXGRTN | Total speed ratio numerator | Positive integer | 16 | 1 (Same as above) | 1 | Total speed ratio numerator of additional axis |
| AXGRTD | Total speed ratio denominator | Positive integer | 16 | 1 (Same as above) | 10 | Total speed ratio denominator of additional axis |
| AXMREV | Rated speed | Positive integer | 16 | 1 (Same as above) | 2000 | Rated speed (Unit: r/min.) of motor or Rated speed (Unit: mm/s.) of linear motor |
| AXJMX | Maximum speed | Positive integer | 16 | 1 (Same as above) | 3000 | Maximum speed (Unit: r/min.) of motor or Maximum speed (Unit: mm/s.) of linear motor |
| AXENCR | Encoder resolution | Positive integer | 16 | 1 (Same as above) | 4194304 | Encoder resolution of motor (Unit: pulse/rev) |
| AXJOGTS | JOG smoothening time constant | Positive real number | 16 | 1 (Same as above) | 150.00 | If it vibrates at JOG, set a larger value. (Unit: ms) |
| MEJAR | Joint operating range | A real number of -131072.00 to +131072.00 | 16 | 2 (per axis of robot) | -80000.0, 80000.0 | Operating range. The minimum values and maximum values are described in this order. (Unit: degree or mm) |
| USERORG | User designated origin | A real number of -80000.00 to 80000.00 | 8 | 1 (per control axis of servo) | 0.00 | Designate the origin position designated by the user. Set a value within the range set in MEJAR (joint operating range). (Unit: degree or mm) |

8. User Mechanism Settings, Operation, and Commands

| Parameter name | Content | Settable range | Number of elements | Number of elements per axis | Default value | Explanation |
|-------------------------------------------------------|----------------------|-----------------------------------------------------------------------------------|--------------------|-----------------------------|-------------------|-----------------------------------------------------------------------------------------------------------------------------------------------------------------------------------------------------------------------------------------------------------------------------|
| AREA*CS (* is 1 to 32) | User definition area | 0, 1 | 1 | --- | 0 | Specify the coordinate system of the area. World coordinate system/Base coordinate system: 0/1 |
| AREA*P1 (* is 1 to 32) | | A real number of -80000.00 to 80000.00 | 8 | 1 (Same as above) | XYZ=0 ABC=-360 | Position data of the area's first point: XYZ (Unit: degree or mm) |
| AREA*P2 (* is 1 to 32) | | A real number of -80000.00 to 80000.00 | 8 | 1 (Same as above) | XYZ=0 ABC=360 | Position data of the area's second point: XYZ (Unit: degree or mm) |
| AREA*ME (* is 1 to 32) | | 0 to 3 | 1 | --- | 0 | Target mechanism number |
| AREA*AT (* is 1 to 32) | | 0 to 2 | 1 | --- | 0 | Specify the behavior upon entering the area. Disable/signal output/error: 0/1/2 |
| USRAREA | | -1 (disabled) The signal number differs depending on the system configuration. | 2 | --- | -1,-1 | Define the number of the signal that outputs the status. |
| MnSRVOFF (n = 1 to 3) | | -1 (disabled) The signal number differs depending on the system configuration. | 2 | --- | -1,-1 | Element 1: Set the input signal number. This signal turns OFF the servo for each mechanism. n=1 to 3. The servo cannot be turned ON while this signal is being input. Element 2: Set the output signal number. Outputs the servo ON disabled state. (Echo back) |
| MnSRVON (n = 1 to 3) (Operation right required) | | -1 (disabled) The signal number differs depending on the system configuration. | 2 | --- | -1,-1 | Element 1: Set the input signal number. Turns the servo for each mechanism ON. n=1 to 3. Element 2: Set the output signal number. Outputs the servo ON state. n=1 to 3. |

8. User Mechanism Settings, Operation, and Commands

8.2.2 Details of parameters

Here, the parameters are described in details.

- (1) AXUNUM (number of multi mechanisms used)
- (2) AXMENO (mechanism No. designation)
- (3) AXJNO (Setting axis No.)
- (4) AXUNT (unit system)
- (5) AXSPOL (motor rotation direction)
- (6) AXACC (acceleration time) · AXDEC (deceleration time)
- (7) AXGRTN (total speed ratio numerator) · AXGRTD (total speed ratio denominator)
- (8) AXMREV (rated rotation speed) · AXJMX (maximum rotation speed) · AXENCR (encoder resolution)
- (9) AXJOGTS (JOG smoothing time constant)
- (10) MEJAR (joint operating range)
- (11) USERORG (user designated origin)
- (12) About the User Definition Area

Moreover, the parameter elements of (2) to (9) correspond to the control axis Nos. of the servo as shown in "Fig. 8.2.1 Control axis No. and parameter element of servo". If any personal computer support software (which enables the program editing, parameter setting, various monitors and so on of the robot) is used, (10) and (11) are the mechanical parameters and the others are arranged in the common parameters.

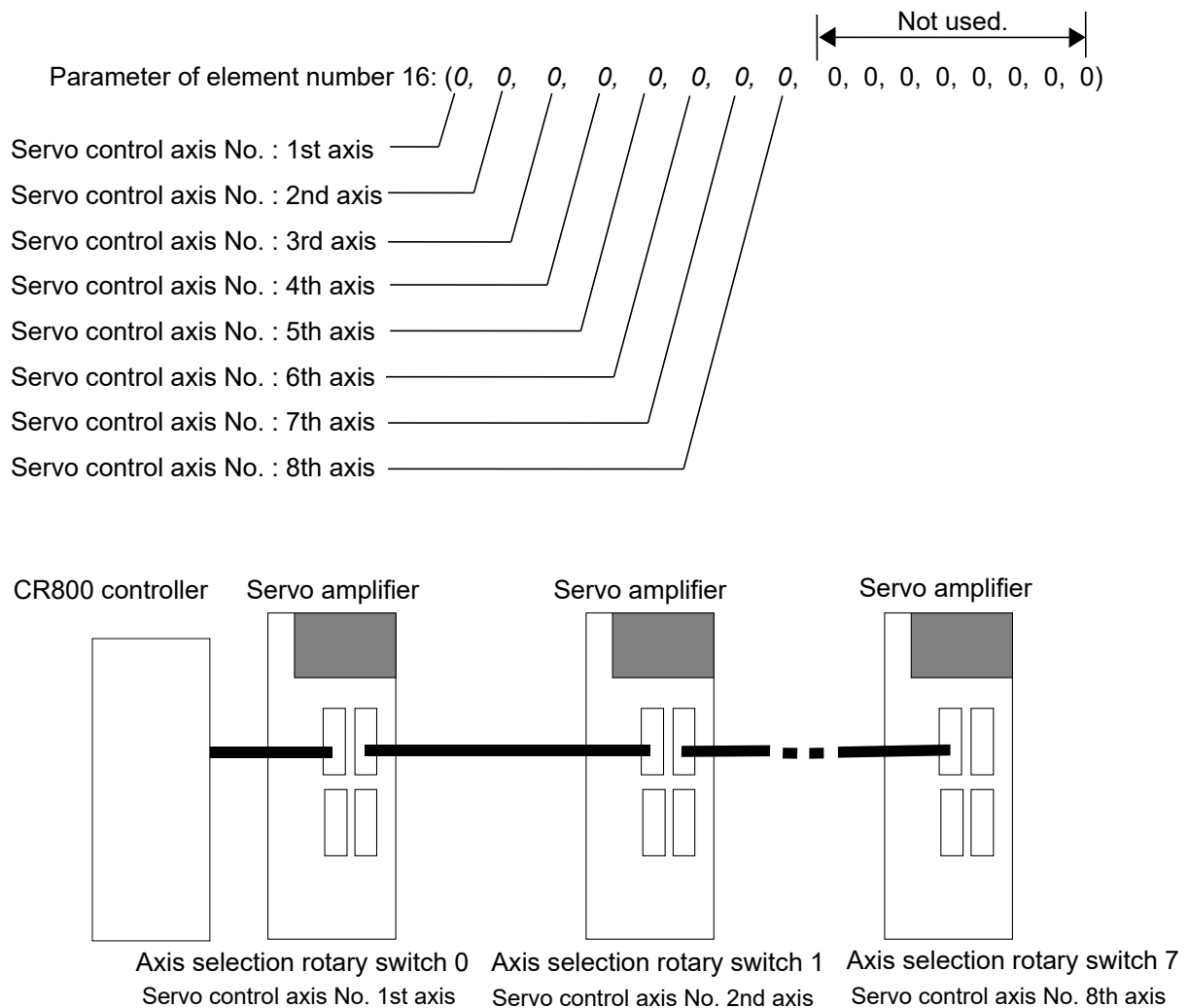

Fig. 8.2.1 Control No. and parameter element of servo

8. User Mechanism Settings, Operation, and Commands

(1) AXUNUM (number of multi mechanisms used)

This parameter designates how many mechanisms are connected when the additional axis is used as the multi mechanism. Max. 2 mechanisms can be connected. When one multi mechanism is connected, the mechanism No. of the connected mechanism automatically become 2. When two mechanisms are connected, the mechanism Nos. become 2 and 3. Moreover, when a mechanism is once set but is deleted, change AXUNUM and set "0" to the AXMENO which corresponds to the mechanism No. deleted.

| | |
|-------------------------------------------------------|---|
| Any additional axis is not used. | 0 |
| One additional axis is used as the multi mechanism. | 1 |
| Two additional axes are used as the multi mechanisms. | 2 |

(2) AXMENO (mechanism No. designation)

This parameter sets which mechanism the servomotor connected to the servo amplifier is connected to regarding each axis.

| | |
|-----------------------------|---|
| Not used. | 0 |
| Used as 1st mechanism axis. | 1 |
| Used as 2nd mechanism axis. | 2 |
| Used as 3rd mechanism axis. | 3 |

[Example]

When the servomotor set "Control axis No. of servo" as the 1st axis is used as the multi mechanism (number of mechanisms: 1 unit and number of mechanism axes: 1 axis), set the parameter AXMENO as follows.

AXMENO = 2, 0, 0, 0, 0, 0, 0, 0, 0, 0, 0, 0, 0, 0, 0, 0 (Set "2" to the 1st element.)

(3) AXJNO (Setting axis No.)

Regarding each axis, this parameter sets what number axis of the robot or mechanism the servomotor is used as. To change an axis No. which has been set once (example: 1st axis → 2nd axis), first set "0" at AXMENO and turn the power supply of the controller from OFF to ON. The default value is "0".

| | |
|-----------------------|---|
| 1st axis of mechanism | 1 |
| 2nd axis of mechanism | 2 |
| 3rd axis of mechanism | 3 |

[Example]

When the servomotor set "Control axis No. of servo" as the 1st axis is used as the 1st axis of the mechanism,

AXJNO = 1, 0, 0, 0, 0, 0, 0, 0, 0, 0, 0, 0, 0, 0, 0 (Set "1" to the 1st element.)

8. User Mechanism Settings, Operation, and Commands

(4) AXUNT (unit system)

Regarding each axis, this parameter sets the unit system of the servomotor, which can be used.

| | |
|-----------------------------------------------------------|---|
| Used as the rotation axis. (Unit: degree) (Default value) | 0 |
| Used as the linear drive axis (Unit: mm) | 1 |
| Use the linear servo (Unit: mm) | 2 |

[Example]

When the servomotor set "Control axis No. of servo" as the 1st axis is used as the linear drive axis (Unit: mm),

AXJNO = 1, 0, 0, 0, 0, 0, 0, 0, 0, 0, 0, 0, 0, 0, 0, 0 (Set "1" to the 1st element.)

When linear servo is connected to the axis which set to 2nd axis as the "Control axis No. of servo"

AXUNT = 0, 2, 0, 0, 0, 0, 0, 0, 0, 0, 0, 0, 0, 0, 0, 0 (Set "2" to the 2nd element.)

(5) AXSPOL (motor rotation direction)

Regarding each axis, this parameter sets in which direction the servomotor is rotated when the joint position data is increased. The rotation direction is illustrated in the parameter details of "Instruction Manual for Servo Amplifier".

Moreover, set the rotation direction with the robot controller.

| | |
|-------------------------------------------------------------------------------------|---|
| Forward run (CCW) (default value) as the value of the joint coordinate is increased | 0 |
| Reverse run (CW) as the value of the joint coordinate is increased | 1 |

Here, be sure to set "POL" parameter of the basic parameter No. 7 of the servo amplifier to "0" (CCW).

[Example]

When the rotation direction of the servomotor set "Control axis No. of servo" as the 1st axis is reversed as the joint position data is increased,

AXSPOL = 1, 0, 0, 0, 0, 0, 0, 0, 0, 0, 0, 0, 0, 0, 0, 0 (Set "1" to the 1st element.)

(6) AXACC (acceleration time) · AXDEC (deceleration time)

Regarding each axis, these parameters set the acceleration/deceleration time from the stop state to the maximum speed when the override of the servomotor which can be used is 100%. The default value is 0.20 (seconds).

[Example]

When the acceleration/deceleration time of the servomotor set "Control axis No. of servo" as the 1st axis is set as follows,

| | |
|-------------------|----------------|
| Acceleration time | 0.40 (seconds) |
| Deceleration time | 0.40 (seconds) |

AXACC = 0.40, 0.20, 0.20, 0.20, 0.20, 0.20, 0.20, 0.20, 0.20, 0.20, 0.20, 0.20, 0.20, 0.20, 0.20, 0.20 (Set "0.40" to the 1st element.)

AXDEC = 0.40, 0.20, 0.20, 0.20, 0.20, 0.20, 0.20, 0.20, 0.20, 0.20, 0.20, 0.20, 0.20, 0.20, 0.20, 0.20 (Set "0.40" to the 1st element.)

(7) AXGRTN (total speed ratio numerator) · AXGRTD (total speed ratio denominator)

These parameters set the numerator and denominator of the total speed ratio of the servomotor which can be used. As the total speed ratio, set a reduced fraction of the integers of the numerator and denominator ($1/18.5 \rightarrow 2/37$). The default value of AXGRTN is "1", and the default value of AXGRTD is "10". When using the linear servo motor, the setting methods differ. Please refer to "this manual/8.2.3 About using the linear servo motor".

[Example]

When the total speed ratio of the servomotor axis set "Control axis No. of servo" as 1st axis is $25/8(\text{mm/rev})$,

AXGRTN = 25, 1, 1, 1, 1, 1, 1, 1, 1, 1, 1, 1, 1, 1, 1 (Set "25" to the 1st element.)

AXGRTD = 8, 10, 10, 10, 10, 10, 10, 10, 10, 10, 10, 10, 10, 10, 10 (Set "8" to the 1st element.)

The total speed ratio of the direct moving axis is calculated as follows. From the relationship of the gear ratio and ball screw lead of "Fig. 8.2.2 Inside of direct moving unit", the movement amount of the load per rotation of the motor is as follows.

$$5 \times 5/8 = 25/8 \text{ [mm/rev]}$$

Accordingly, since the motor speed when the load is moved 1mm becomes $8/25$ rotation, the total speed ratio becomes as follows.

$$\text{AXGRTN/AXGRTD} = 1 / (8/25) = 25/8$$

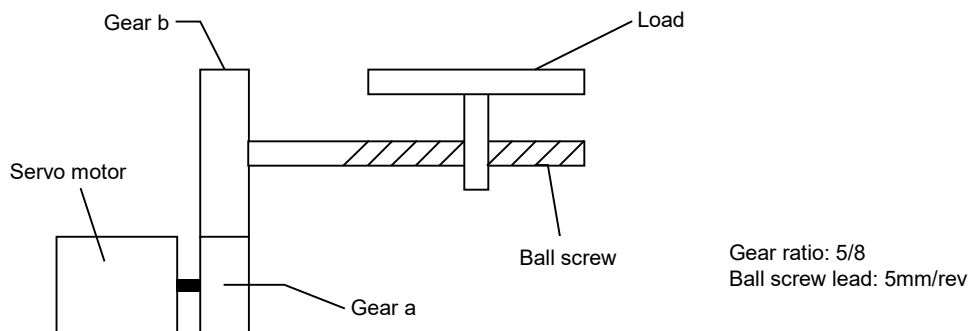

Fig. 8.2.2 Inside of direct moving unit

The total speed ratio of the rotation axis is calculated as follows. When the table of "Fig. 8.2.3 Inside of rotation table" rotated one rotation (360 degrees), the motor speed becomes 10 rotations. Therefore, the total speed ratio becomes as follows.

$$\text{AXGRTN/AXGRTD} = 1/10$$

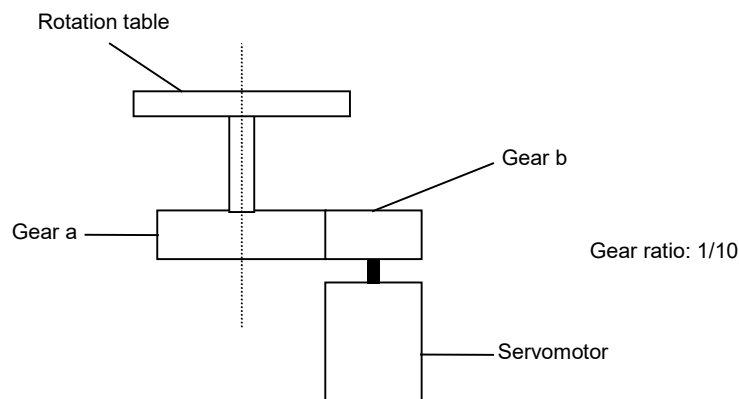

Fig. 8.2.3 Inside of rotation table

8. User Mechanism Settings, Operation, and Commands

- (8) AXMREV (rated rotation speed) · AXJMX (maximum rotation speed) · AXENCN (encoder resolution)

These parameters set the properties of the servomotor, which can be used. Referring to the specifications in "Instruction Manual for Servo Amplifier", set the values which are suitable for the applied servomotor. The default value of AXMREV is 2000(r/min.), the default value of AXJMX is 3000(r/min.) and the default value of AXENCN is 4194304 (pulse/rev). When using the linear servo motor, the setting methods differ. Please refer to "this manual/8.2.3 About using the linear servo motor".

[Example]

When the properties of the servomotor set "Control axis No. of servo" as the 1st axis are as follows.

| | |
|--------------------|--------------------|
| Rated speed | 3000 (r/min) |
| Maximum speed | 4000 (r/min) |
| Encoder resolution | 131072 (pulse/rev) |

AXMREV = 3000, 2000, 2000, 2000, 2000, 2000, 2000, 2000, 2000, 2000, 2000, 2000, 2000, 2000, 2000, 2000, 2000
(Set "3000" to the 1st element.)

AXJMX = 4000, 3000, 3000, 3000, 3000, 3000, 3000, 3000, 3000, 3000, 3000, 3000, 3000, 3000, 3000, 3000, 3000, 3000
(Set "131072" to the 1st element.)

AXENCN = 131072, 4194304, 4194304, 4194304, 4194304, 4194304, 4194304, 4194304, 4194304, 4194304, 4194304, 4194304, 4194304, 4194304, 4194304
(Set "131072" to the 1st element.)



CAUTION

In MANUAL mode, the maximum speed of an additional axis is 10% of the value set in parameter AXJMX.

Therefore, when operating the robot mounted on a travel axis (additional axis) in MANUAL mode, set parameter AXJMX so that the operating speed (composite speed) of the robot including the travel axis does not exceed the safe speed (250 mm/s).

- (9) AXJOGTS (JOG smoothening time constant)

Set this parameter to reduce the vibration if it occurs during jog of the additional axis. If any excessive value is set, the acceleration/deceleration time becomes long during jog operation. The settable value is in the range of positive real numbers. The default value is 150.00 (ms).

[Example]

When this parameter value is set to "200.00" against vibration of the axis set "Control axis No. of servo" as the 1st axis,

AXJOGTS = 200.00, 150.00, 150.00, 150.00, 150.00, 150.00, 150.00, 150.00, 150.00, 150.00, 150.00, 150.00, 150.00, 150.00, 150.00, 150.00, 150.00
(Set "200.00" to the 1st element.)

(10) MEJAR (joint operating range)

For this parameter, set the motion range of the additional axis in order of minimum value and maximum value. To set the additional axis of multi-mechanisms, change all parameters excluding the user designated origin (USERORG) parameters, and then turn the power from off to on. Next, select a user mechanism to be used, and then set this parameter. The settable values are real numbers in the range of -131072.00 to +131072.00. The default values are -80000.00, 80000.00.

[Example]

When it is used as the multi mechanism (number of mechanism axes: 1 axis), set the motion range as follows.

Minimum value -2000mm
Maximum value 3000mm

MEJAR = -2000.00, 3000.00, 0.00, 0.00, 0.00, 0.00, 0.00, 0.00, 0.00, 0.00, 0.00, 0.00, 0.00, 0.00, 0.00, 0.00, 0.00

(Set -2000.00 at the 1st element and 3000.00 at the 2nd element.)

<Note>

Cannot move to the position exceeding operating range as following. Please set up the operating range (MEJAR) in the range which satisfies the following formula sure. Take care since the operating range changes with set-up values of the encoder resolution setup (AXENCR) and the total reduction ratio setup (AXGRTN, AXGRTD)

| | Operatingrange |
|---------------------|--------------------------------------------------------------------------------------------------------------------------------------------------------------------------------------------------------------------------|
| Linear axis (mm) | $-\left(\frac{2^{31}}{\text{AXENCR}} - 50\right) \times \frac{\text{AXGRTN}}{\text{AXGRTD}} \leq x \leq \left(\frac{2^{31}}{\text{AXENCR}} - 50\right) \times \frac{\text{AXGRTN}}{\text{AXGRTD}}$ |
| Rotation axis (deg) | $-360 \times \left(\frac{2^{31}}{\text{AXENCR}} - 50\right) \times \frac{\text{AXGRTN}}{\text{AXGRTD}} \leq x \leq 360 \times \left(\frac{2^{31}}{\text{AXENCR}} - 50\right) \times \frac{\text{AXGRTN}}{\text{AXGRTD}}$ |

(x : The position which robot moves (coordinate value))

<Example>

If the axis is the rotation type, and if the encoder resolution and the total reduction ratio are the following, the operating range (setting value of MEJAR) is -1663.20 (deg) to +1663.20 (deg).

<Encoder resolution, the total reduction ratio>

AXENCR=4194304
AXGRTN=1
AXGRTD=100

(11) USERORG (user designated origin)

This parameter sets the origin position set when the user designated origin is set. The origin of the additional axis set here is also reflected on the other origin setting method (mechanical stopper, jig and ABS system). To set the additional axis of multi-mechanisms, change all parameters excluding the joint operating range (MEJAR) parameter, and then turn the power from off to on. Next, select a user mechanism to be used, and then set this parameters. The settable value is in the range of -131072.00 to +131072.00, being a real number in the range set at MEJAR (joint operating range).

[Example]

When it is used as the multi mechanism (number of mechanism axes: 1 axis), set the user designated origin as follows.

Origin position designated by the user 1500mm

USERORG = 1500.00, 0.00, 0.00, 0.00, 0.00, 0.00, 0.00, 0.00 (Set "1500.00" to the 1st element.)



The MEJAR (joint operating range) and USERORG (user designated origin) parameters must be set for each user mechanism selected. When setting the values for the additional axis to be used as multi-mechanisms, exercise caution so as not to change the robot axes by mistake.

8. User Mechanism Settings, Operation, and Commands

(12) About the User Definition Area

When working together with peripheral devices, the range of work may be shared. It is necessary to notify others that one is in the shared area. In such a case, a signal can be output by setting the applicable parameter while the user mechanism is within an arbitrary range. An example using the following user mechanism (mechanism number 2) will be explained.

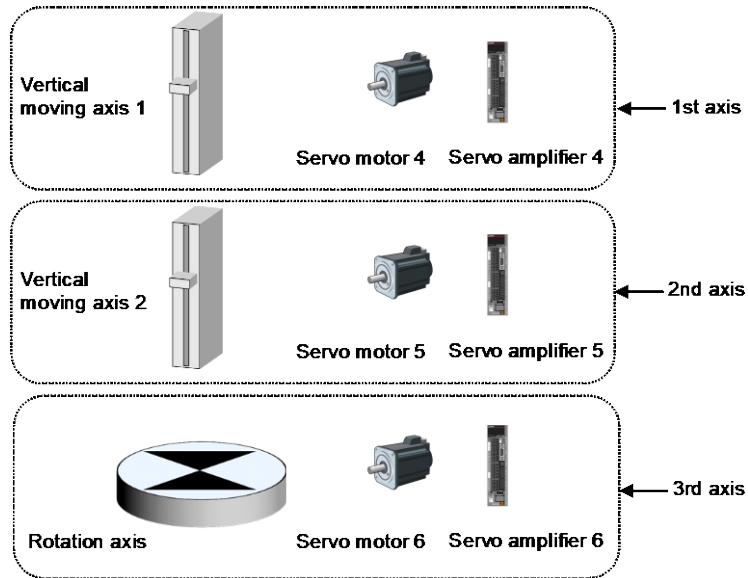

To output the output number 10080 when the first axis is working in the range 1, the output number 10081 when the second axis is working in the range 2, and the output number 10082 when the third axis is working in the range 3, set the parameters as follows.

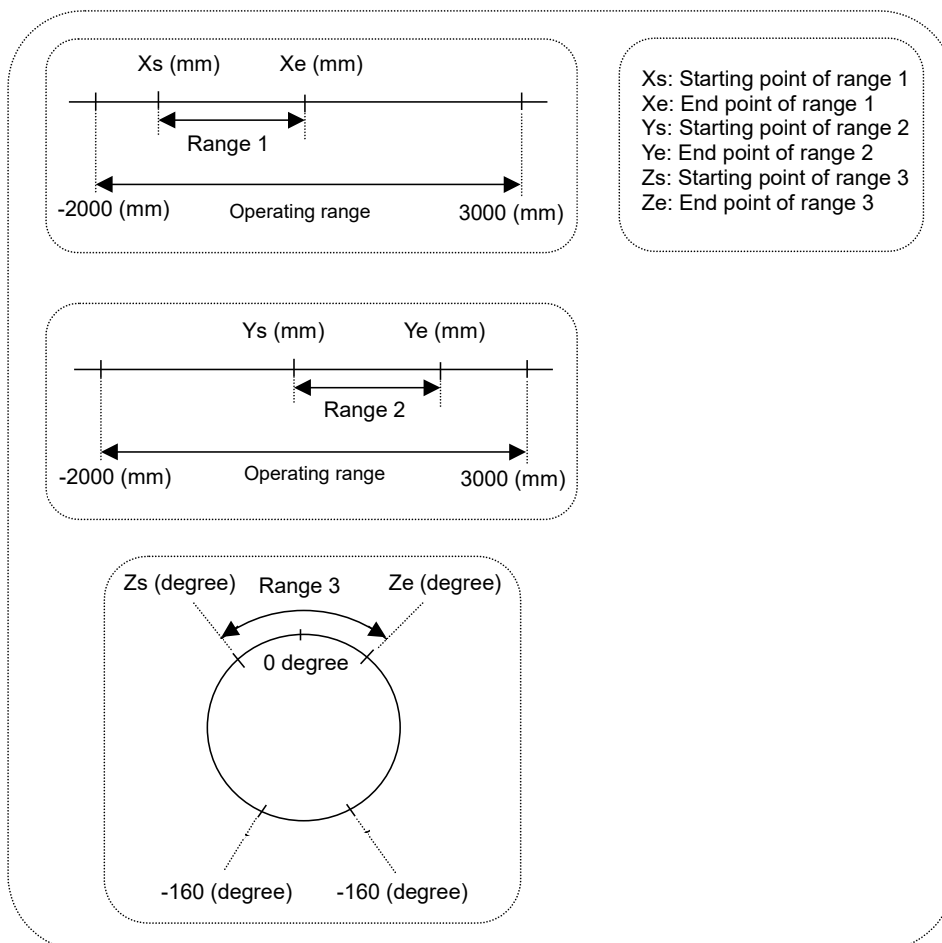

8. User Mechanism Settings, Operation, and Commands

| Parameter name | Meaning of the value | Value |
|----------------|--------------------------------------------------------------------------------------------------------------------------------------------------------------------------------------------------------------------------------------------------------------|---------------------------------------|
| AREA1CS | Specify the coordinate system of the area. World coordinate system/Base coordinate system: 0/1 | 0 |
| AREA1P1 | Position data for the first point: X,Y,Z Unit: degree or mm | Xs,-10000,-360,-360,-360,-360,0,0 |
| AREA1P2 | Position data for the second point: X,Y,Z Unit: degree or mm | Xe,10000,360,360,360,360,0,0 |
| AREA1ME | Target mechanism number. In this case the value is 2. | 2 |
| AREA1AT | Specify the behavior upon entering the area. Invalid /signal output/error: 0/1/2 Invalid : This function will be invalid. Signal output : The dedicated output signal USRAREA will turn ON. Error: An error is generated when entering the area. | 1 |
| AREA2CS | Specify the coordinate system of the area. World coordinate system/Base coordinate system: 0/1 | 0 |
| AREA2P1 | Position data for the first point: X,Y,Z Unit: degree or mm | -10000,Ys,-360,-360,-360,-360,0,0 |
| AREA2P2 | Position data for the second point: X,Y,Z Unit: degree or mm | 10000,Ye,360,360,360,360,0,0 |
| AREA2ME | Target mechanism number. In this case the value is 2. | 2 |
| AREA2AT | Specify the behavior upon entering the area. Invalid /signal output/error: 0/1/2 Invalid : This function will be invalid. Signal output : The dedicated output signal USRAREA will turn ON. Error: An error is generated when entering the area. | 1 |
| AREA3CS | Specify the coordinate system of the area. World coordinate system/Base coordinate system: 0/1 | 0 |
| AREA3P1 | Position data for the first point: X,Y,Z Unit: degree or mm | -10000, -10000, Zs,-360,-360,-360,0,0 |
| AREA3P2 | Position data for the second point: X,Y,Z Unit: degree or mm | 10000,10000,Ze,360,360,360,0,0 |
| AREA3ME | Target mechanism number. In this case the value is 2. | 2 |
| AREA3AT | Specify the behavior upon entering the area. Invalid /signal output/error: 0/1/2 Invalid : This function will be invalid. Signal output : The dedicated output signal USRAREA will turn ON. Error: An error is generated when entering the area. | 1 |

8. User Mechanism Settings, Operation, and Commands

| Parameter name | Meaning of the value | Value |
|----------------|--------------------------------------------------------------------------------------------------------|-----------------------------------------------------------------------------------------------------------------------------------------------------------------------------------------------------------------------------------------------------|
| USRAREA | Define the number of the signal that outputs the status. Output signal: starting number, end number | 10080,10082 (Information on whether it is within AREA1* is output to the signal 100080, information on whether it is within AREA2* is output to the signal 10081, and information on whether it is within AREA3* is output to the signal 10082.) |

- *1 Enter the coordinates of each axis in each of Xs, Xe, Ys, Ye, Zs and Ze.
- *2 Set a value exceeding the movement range for the axis to be disabled, so that it will be always working within the area.
- *3 When the base coordinate system of the user mechanism is not changed, AREA*CS does not need to be changed. For the differences of the user-defined area functions by specifying the coordinate system, refer to About user-defined area in "INSTRUCTION MANUAL/Detailed explanations of functions and operations".

8.2.3 About using the linear servo motor

When using the linear servo motor, set the total speed ratio parameter (AXGRTN/AXGRTD), the encoder resolution parameter (AXENCN), and the rated speed parameter (AXMREV/AXJMX) as follows.

(1) Resolution related parameter (AXGRTN/AXGRTD/AXENCN) setting.

Set up the linear servo motor moving distance per one pulse of linear encoder as follows.

$$\text{Moving distance per one pulse (mm)} = \frac{\text{AXGRTN}}{\text{AXGRTD}} \times \frac{1}{\text{AXENCN}}$$

[Example]

When the resolution of linear servo motor which set the "Control axis No. of servo" to the 1st axis is the following.

Linear encoder resolution: 0.05μm

$$\text{Moving distance per one pulse (mm)} = \frac{0.05 \times 10^{-3} \text{ [mm]}}{1 \text{ [pulse]}} = \frac{1}{20000}$$

$$\frac{\text{AXGRTN}}{\text{AXGRTD}} \times \frac{1}{\text{AXENCN}} = \frac{1}{20000}$$

[Example of set value]

ACGRTN = 1

AXGRTD = 1

AXENCN = 20000

Therefore, the parameter set value is as follows.

AXGRTN = (1, 1, 1, 1, 1, 1, 1, 1, 1, 1, 1, 1, 1, 1, 1, 1) (Set the 1st element to 1.)

AXGRTD = (1, 10, 10, 10, 10, 10, 10, 10, 10, 10, 10, 10, 10, 10, 10, 10) (Set the 1st element to 1.)

AXENCN = (20000, 4194304, 4194304, 4194304, 4194304, 4194304, 4194304, 4194304, 4194304, 4194304, 4194304, 4194304, 4194304, 4194304, 4194304) (Set the 1st element to 20000.)

8. User Mechanism Settings, Operation, and Commands

(2) Speed related parameter (AXMREV/ AXJMX) setting

Set the rated speed and maximum speed as the parameter AXMREV (rated speed) and AXJMX (maximum speed)
(Unit: mm/s)

<Note>

When using the linear servo motor, set the set value of parameter AXUNT (unit system) to "2."
(Refer to "this manual/8.2.2 Details of parameters (4) AXUNT (unit system)")

[Example]

When the specification of linear servo motor which set the "Control-axis-No.-of-servo" to 1st axis are the following.

Rated speed 1800 (mm/s)

Maximum speed 2000 (mm/s)

AXMREV = (800, 2000, 2000, 2000, 2000, 2000, 2000, 2000, 2000, 2000, 2000, 2000, 2000, 2000, 2000, 2000, 2000, 2000, 2000)

AXJMX = (2000, 3000, 3000, 3000, 3000, 3000, 3000, 3000, 3000, 3000, 3000, 3000, 3000, 3000, 3000, 3000, 3000, 3000, 3000)



In MANUAL mode, the maximum speed of an additional axis is 10% of the value set in parameter AXJMX.

Therefore, when operating the robot mounted on a travel axis (additional axis) in MANUAL mode, set parameter AXJMX so that the operating speed (composite speed) of the robot including the travel axis does not exceed the safe speed (250 mm/s).

8.3 Confirmation of connection

Before use, confirm the following items again.

Confirmation of connection

| No. | Confirmation item | Check |
|-----|----------------------------------------------------------------------------------------------------------------------------------------------------------|-------|
| 1 | Is the teaching pendant securely fixed? | |
| 2 | Is the exclusive communication cable properly connected between the controller and servo amplifier? (Refer to "Instruction Manual for Servo Amplifier".) | |
| 3 | Is the detector cable properly connected between the servo amplifier and motor? (Refer to "Instruction Manual for Servo Amplifier".) | |
| 4 | Is the servomotor power cable properly connected between the servo amplifier and motor? (Refer to "Instruction Manual for Servo Amplifier".) | |
| 5 | Is the ground wire properly connected between the servo amplifier and motor? (Refer to "Instruction Manual for Servo Amplifier".) | |
| 6 | Is the ground cable from the servo amplifier properly grounded? (Refer to "Instruction Manual for Servo Amplifier".) | |
| 7 | Is the brake unit properly connected? (Refer to "Instruction Manual for Servo Amplifier".) (When it is used,) | |
| 8 | Is the emergency stop circuit properly connected? (Refer to "Instruction Manual for Servo Amplifier".) (When it is used,) | |
| 9 | Are the parameters of the additional axis interface properly set? (Refer to "this manual/8.2Description of parameters".) | |
| 10 | Are the parameters of the servo amplifier properly set? (Refer to "Instruction Manual for Servo Amplifier".) | |
| 11 | Is the basic parameter PA03 ABS of the servo amplifier set to "0001"? (Refer to "Instruction Manual for Servo Amplifier".) | |
| 12 | Is the basic parameter PA14 POL of the servo amplifier set to "0"? (Refer to "Instruction Manual for Servo Amplifier".) | |
| 13 | Is the power supply of the controller turned OFF once after the parameters are set? | |
| 14 | Is the axis selection rotary switch (SW1) of the servo amplifier properly set? | |

After the preparation is completed, turn OFF the power supply of the additional axis system.

8. User Mechanism Settings, Operation, and Commands

8.4 Try to use the mechanical additional axis.

This chapter describes the basic operation from the power turn-ON through operation to end using the user mechanism.

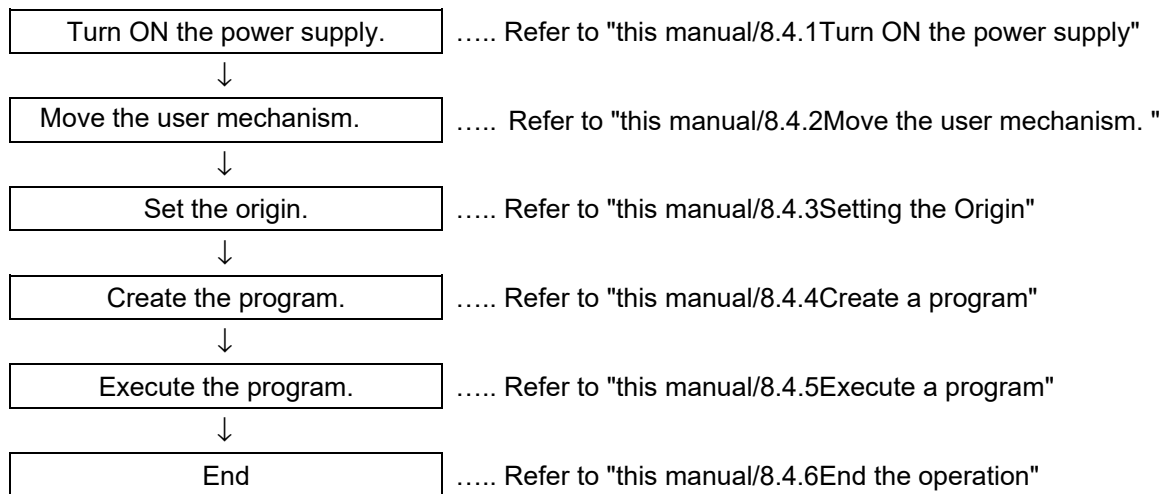

CAUTION

If any vibration occurs or any operation is not satisfied during operation of the additional axis, it is necessary to adjust (tune) the servo system. Referring to "Instruction Manual for Servo Amplifier and Servomotor", adjust it.



CAUTION

If any motor, absolute position detector, etc., is replaced or any parameter related to the mechanism or axis configuration is changed, be sure to confirm the current position before moving. If any origin position deviation, etc., is found, set the origin again. The above parameters are the multi mechanism applied quantity (AXUNUM), mechanism No. designation (AXMENO), setting axis No. (AXJNO), unit system (AXUNT), rotation direction (AXSPOL) and endoder resolution (AXENCR).

8.4.1 Turn ON the power supply

Confirm the safety around the robot and additional axis and turn ON the power supply.

- (1) Turn ON the power supply of the servo system.
- (2) Turn ON the power supply of the controller.



CAUTION



Turn ON the power supply of the peripheral device earlier than the robot controller. If the power supply of the robot controller is turned ON earlier than the peripheral device, the robot controller may sometimes not recognize the peripheral device.

8.4.2 Move the user mechanism.

Move the axis by jog the additional axis of the teaching pendant. The following describe such a case as the mechanical additional axis of the 3-axis XYZ coordinate mechanism (mechanism No. 2) is operated.

- (1) Turn the "ENABLE/DISABLE" switch of the teaching pendant to "ENABLE".
- (2) Then, proceed with "this manual/Table 8.4.1 User mechanism, jog operation, jog operation".

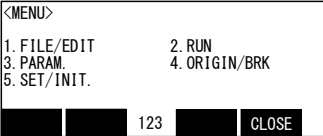
Table 8.4.1 User mechanism, jog operation

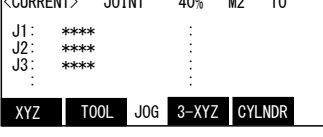
| N O | Teaching pendant screen display | Work details |
|--------|--------------------------------------------------------------------------------------------------------------------------------|----------------------------------------------------------------------------------------------------------------------------------------------------------------------------------------------------------------------------------------------------------------------------------------------------------------------------------------------------------------------------------------------------------------------------------------------------------------------------------------------------------------------------------------|
| 1 | | Press [EXE] key to display screen 2. |
| 2 |  <p>Example: The robot's type is RV-7FR-D</p> | Press [2] key to select USER of the mechanism No.2. |
| 3 |  | Pressing the Enable switch (3-position enable switch) on the rear of the teaching pendant, press [SERVO] key and turn ON the servo. Keeping the Enable switch (3-position enable switch) pressed, proceed with the following operation. If the Enable switch (3-position enable switch) is released in the middle of processing, the servo will be turned OFF. In this case, restart this process from the beginning. |
| 4 |  | Press the key of [JOG], and the jog screen will be displayed . Use the key of [FUNCTION] (change of the jog mode menu), and press the key of [F1] to [F4], and select the "joint" jog mode. |
| 5 |  | <p>[+X(J1)] key : The axis 1 moves in the + direction. [-X(J1)] key : The axis 1 moves in the - direction. [+Y(J2)] key : The axis 2 moves in the + direction. [-Y(J2)] key : The axis 2 moves in the - direction. [+Z(J3)] key : The axis 3 moves in the + direction. [-Z(J3)] key : The axis 3 moves in the - direction.</p> <p>Release the axis designation key, and the user mechanism will stop.</p> |
| 6 |  | <p>[OVRD ↑] key increases the jog speed. [OVRD ↓] key decreases the jog speed.</p> <p>The percentage display of the speed is different depending on each model.</p> |

- Note 1) A mechanism which is not used is not displayed on the teaching pendant screen.
 Note 2) An axis which is not used is not displayed on the teaching pendant screen.
 Note 3) When the origin has been already set, the current position of the additional axis will be displayed in the "****" place.

8. User Mechanism Settings, Operation, and Commands

8.4.3 Setting the Origin

Set the origin via the origin operation of the teaching pendant.

The following explains how to set the origin of the three-axis user mechanism (mechanism number 2).

- (1) Set the [ENABLE/DISABLE] switch of the teaching pendant to [ENABLE].
- (2) Determine the user origin position. Move the mechanism to the desired origin position by jog operation.
- (3) Mark the position used in (2) above, such as with a label or mark, so that it can be used for the alignment of all axes by jog operation later when it may be necessary to perform origin setting again.
- (4) Enter the origin position in the USERORG (User-Designated Origin) parameter, and turn off the power to the controller and then turn it on. For details on parameter settings, refer to "8.2 Description of parameters."
- (5) Then, operate as shown below

Table 8.4.2 User origin setting operation

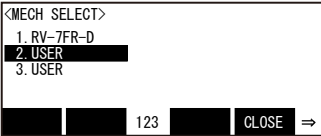
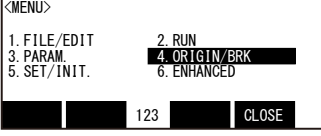
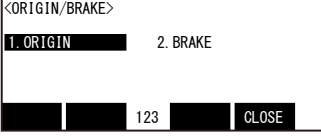
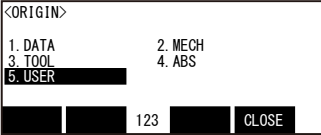
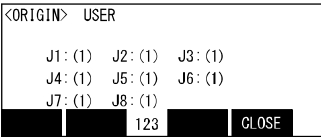
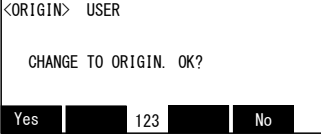
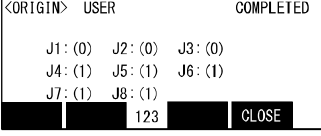
| N O | Teaching pendant screen display | Work details |
|--------|---------------------------------------------------------------------------------------------------------------------------------|--------------------------------------------------------------------------------------------------------------|
| 1 | | Press [EXE] key to display screen 2. |
| 2 |  <p>Example: The robot's type is RV-7FR-D</p> | Press [2] key to select USER of the mechanism No.2. |
| 3 |  | Press the [4] key to select "4.ORIGIN/BRK". |
| 4 |  | Press the [1] key to select "1.ORIGIN". |
| 5 |  | Press the [5] key to select "5.USER". |
| 6 |  | Press the [↓] key, enter "1" in the axis to set the origin with axis specification, and press the [EXE] key. |
| 7 |  | Press the [F1] (Yes) key to perform origin setting. |
| 8 |  | This completes the setting of the origin with the user origin method. |

8.4.4 Create a program

As an example, a program to operate the robot additional axis is created. For the methods of the program input and position data registration, refer to the programming in "Instruction Manual/ Detailed explanations of functions and operations". For the mechanical additional axis, it is necessary to designate the mechanism No. (GETM command). The following shows such a case as the mechanism No. 2 is designated.

```
1 GetM 2
2 Mov P1
3 Dly 1.0
4 Mov P2
5 Dly 1.0
6 End
```



CAUTION

Don't use the joint variable for the designation of the position. Use the position variable.

8.4.5 Execute a program

Try to execute a program created.

From the teaching pendant, confirm the operation in the step feed mode. (For the step feed method, refer to Step feed in the instruction manual of the robot controller.) If any problem does not occur, execute the program in the OPERATION screen of the teaching pendant.

- (1) Press the [ENABLE] button of the teaching pendant to disable the teaching pendant.
- (2) Select "OPERATION" in the "RUN" screen of the teaching pendant to display the OPERATION screen.
- (3) Press the function key [F4] to which "CHOOSE" in the OPERATION screen has been assigned to display the Select robot program screen.
- (4) Enter the name of the program to be executed and press the [EXE] key.
- (5) When the servo is OFF, press the function key [F1] to which "SVO ON" in the "OPERATION" screen has been assigned to turn ON the servo.
- (6) Press the function key [F1] to which "START" in the OPERATION screen has been assigned to execute the program.

For details of the operation procedure, refer to Starting automatic operation in "INSTRUCTION MANUAL/Detailed explanations of functions and operations".

8.4.6 End the operation

Confirm that the program is interrupted or stopped, proceed with the following operation and turn OFF the power supply of the additional axis system.

- (1) Turn the mode switch of the teaching pendant to "DISABLE".
- (2) Select "OPERATION" in the "RUN" screen of the teaching pendant to display the OPERATION screen.
- (3) Press the function key [F2] to which "SVO OFF" in the OPERATION screen has been assigned to turn OFF the robot and the servo of the additional axis.
- (4) Turn OFF the power supply of the controller.
- (5) Turn OFF the power supply of the servo system.

Though an alarm occurs on the servo system side during operation of (4) to (5), continue the operation and shut down the power supply of the servo system, and any problem will not occur.

8. User Mechanism Settings, Operation, and Commands

8.5 Operation of the User Mechanism

This section describes the procedures for operating the additional axis interface for each of the operating functions.

When the additional axis is operated first time after assembling a system, perform origin setting.



CAUTION

If any vibration occurs or any operation is not satisfied during operation of the additional axis, it is necessary to adjust (tune) the servo system. Referring to "Instruction Manual for Servo Amplifier and Servomotor", adjust it.

8.5.1 Brake release

The brake of the robot additional axis can not be released from the robot controller. To release the brake, refer to "Instruction Manual for Servo System".

8.5.2 Origin setting

[Function]

Perform origin setting of the user mechanism.

[Method]

The origin setting of the mechanical additional axis is the same as the origin is set in the standard system. As for the origin setting method, however, use the user origin setting method. For more details, refer to "8.4.3 Setting the Origin."

8.5.3 Servo ON/OFF

[Function]

Turn ON and OFF the servo of the user mechanism.

The servo of the user mechanism is linked with the servo power supply of the robot arm.

The operating method is the same as that of the standard system. For details of the actual servo ON method, refer to the Turning the servo ON/OFF of "Instruction Manual/ Detailed explanations of functions and operations".

8.5.4 Jog operation

[Function]

Move the user mechanism.

The screen and content displayed for this operation are as follows. Here, the unit of the additional axis displayed is set with the parameter (AXUNT) (Angle: degree or Length: mm). For the parameter setting method, refer to "this manual/8.2 Description of parameters".

| <CURRENT> | ADD_AX | 100% | M2 | T00 | B* |
|-----------|--------|------|----|-----|----|
| J1: | 0.00 | : | | | |
| J2: | 0.00 | : | | | |
| J3: | 0.00 | : | | | |
| : | | : | | | |
| : | | : | | | |

JOINT | XYZ | JOG | TOOL | 3-XYZ ⇒

→Display of the current jog mode and mechanism No.

→Display of the current position

[Method]

The additional axis is operated by the jog operation of the teaching pendant. For details, refer to "this manual/8.4.2 Move the user mechanism. "

[Explanation]

- (1) The operating speed can be switched by pressing [OVRD(upper arrow)] (jog speed UP) or [OVRD(lower arrow)] (jog speed DOWN). For details, refer to the jog feed in "Instruction Manual/ Detailed explanations of functions and operations".
- (2) If any operation range or speed limit may be exceeded, the robot will stop with an error.
- (3) Before the origin is set, "****" is displayed at the current position data of the additional axis of the teaching pendant.
- (4) In case of the user mechanism, it becomes the same operation regardless of the jog mode (joint, XYZ, tool, cylinder, 3-axis XYZ, or work).

8.5.5 Operation of position variable

The position variable (position No.) can be operated using the teaching pendant like the standard system.

[Function]

The current position is registered at the position variable (position No.).

[Method]

Press [F2](teach) key, and [F1] (YES) key of confirmation screen.
For details, refer to "Instruction Manual/ Detailed explanations of functions and operations".

8.5.6 Operation

The operation is started like the standard system. For details of the actual operation starting method, etc., refer to separate "Instruction Manual/ Detailed explanations of functions and operations".



If any program execution is interrupted and the additional axis is moved with the jog or servo OFF, it will return to the interrupted position for motion when the program is restarted.

8.5.7 Stop

- Stop

The program in running is stopped, and the robot arm and robot additional axis in moving is decelerated and stopped. In this stopping mode, the servo is kept ON and the brake is not activated. The stop is operated like the standard system. For details of the actual stop method, refer to the stop in "Instruction Manual/ Detailed explanations of functions and operations".

8. User Mechanism Settings, Operation, and Commands

- Emergency stop

The servo is turned OFF, the brake is activated and the robot arm and robot additional axis are immediately stopped. This is called the emergency stop. There are three emergency stop methods as follows.

- (1) Press [EMG.STOP] key of the teaching pendant.
- (2) Emergency stop with the external emergency stop terminal on the rear of the robot controller
- (3) Emergency stop with the emergency stop circuit attached to the servo system

Among them, Items (1) and (2) are carried out like the standard system. For details of the actual emergency stop method, etc., refer to the connecting the external emergency stop in "Instruction Manual/ Controller setup, basic operation, and maintenance".

For the using method and others of Item (3), refer to "Instruction Manual for Servo System" purchased.



CAUTION

Since "Emergency Stop" immediately stops the system, the mechanisms and works may vibrate. Instead, if the situation allows, use "Stop" that employs deceleration stop.

8.5.8 Error resetting

The error resetting is carried out like the standard system. For details of the actual error resetting method, refer to the error reset operation in "Instruction Manual/ Detailed explanations of functions and operations".

8.6 Explanation of commands

The language specifications added and changed are herein described to install the additional axis interface. The applied commands are the same as those of the standard system. However, there are some added points about the describing method of the position variables.



Note that there are some commands that cannot be used in the user mechanism as shown in "8.6.2 Commands".

8.6.1 Position variables



Do not use joint variables to specify the position. Use position variables (including status variables).

(1) The following is described to designate the position of the mechanical additional axis.

[Example]

10 P1=(100, 0, 0, 0, 0, 0)(0, 0)

If the mechanical additional axis is a configuration of 1 axis, the following is described to substitute the value into the position variable P1 at the program step No. 10.

10 P1 = (100,) (0, 0)

"," is necessary after 100.

If the mechanical additional axis is a configuration of 2 axes, the following is described to substitute the value into the position variable P1 at the program step No. 10.

10 P1 = (100, 200) (0, 0)

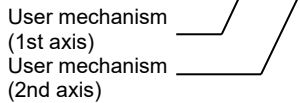

"," can be omitted after 200.

(2) Describe as shown below when specifying the element data of each axis.

1 axisX, 2 axisY, 3 axisZ, 4 axisA, 5 axisB, 6 axisC

[Example]

To change to 50 the Z (J3 axis) value of position variable P3 with program line number 20, describe as shown below

20 P3.Z=50

To specify element data, describe both the rotary axis and linear drive axis as shown above.

(3) The result of the calculation related to the position variable of the additional axis is as follows.

| | |
|-------------------------------------------|--------------------------------------------------------------------------|
| Position variable + (-) Position variable | The element data of the additional axis is also calculated as it is. |
| Position variable × Position variable | The element data of the additional axis is processed in the addition. |
| Position variable ÷ Position variable | The element data of the additional axis is processed in the subtraction. |
| Value variable × (÷) Position variable | The element data of the additional axis is processed as it is. |

(4) The element data of the additional axis of the grid point position of the pallet is calculated like the robot.

8. User Mechanism Settings, Operation, and Commands

8.6.2 Commands

The user mechanism offers instructions, built-in functions and status variables of which operation cannot be guaranteed, as listed below.

In addition, joint variables cannot be used to specify the position. Instead, use the position variable (including status variables).

- Torq command
- Optimum acceleration/deceleration related (Oad/LoadSet)
- High accuracy mode related (Prec)
- Compliance related (Cmp/CmpG/M_CmpDst)
- Structure flag, multi-rotation information related (RDFL1/RDFL2/SETFL1/SETFL2)
- Align function
- Fine command ^{Note)}
- Spd command
- Mvs command
- Circular interpolation instruction related (Mvr/Mvr2/Mvr3/Mvc)
- DISTfunction, ZONE2 function
- M_RDst (remaining distance), M_Ratio (arrival ratio), M_Spd/M_NSpd/M_RSpd (XYZ speed related) status variables
- Fram function
- Joint variables (including status variables of joint variable type)
- Impact detection function (ColChk/ColLvl)
- Singular point passage function (Type 0, 2)
- Spline interpolation command (MvSpl)
- Ex-T spline interpolation command (EMvSpl)
- Force function related commands (Fsc, FsGChg, FsCTrg, etc.)

Note) The Fine instruction can set whether the function is enabled/disabled, but cannot set the number of pulses. If you are using the Fine instruction, set the number of pulses using the servo amplifier's INP parameter. For more details, refer to separate "Instruction Manual/ Detailed explanations of functions and operations" and the Servo Amplifier Instruction Manual.

8. User Mechanism Settings, Operation, and Commands

The following shows a list of status variables, built-in functions and instruction languages that can be used without any problems

(1) Robot status variables that operate without any problem in the user mechanism

| Variable name | Array designation Note1) | Details | Attribute Note2) | Data type, Unit |
|---------------|-----------------------------|----------------------------------------------------------------------------------------------------------------------------------------------------------------------------------|---------------------|--------------------------------------|
| P_Curr | Mechanism No.(1 to 3) | Current position (XYZ) | R | Position type |
| P_Fbc | Mechanism No.(1 to 3) | XYZ position generated based on the feedback value from the servo | R | Position type |
| P_Tool | Mechanism No.(1 to 3) | Currently designated tool conversion data | R | Position type |
| P_Base | Mechanism No.(1 to 3) | Currently designated base conversion data | R | Position type |
| P_NTool | Mechanism No.(1 to 3) | System default value (tool conversion data) | R | Position type |
| P_NBase | Mechanism No.(1 to 3) | System default value (base conversion data) | R | Position type |
| M_OPovrd | None | Current speed override on the operation panel (0 to 100%) | R | Integer type, % |
| M_Ovrd | Slot No.(1to 32) | Current override in designated program (0 to 100%) | R | Integer type, % |
| M_JOvrd | Slot No.(1to 32) | Current joint override (0 to 100%) | R | Integer type, % |
| M_NOvrd | Slot No.(1to 32) | System default value (default value of M_Ovrd) (%) | R | Single-precision real number type, % |
| M_NJovrd | Slot No.(1to 32) | System default value (default value of M_JOvrd) (%) | R | Single-precision real number type, % |
| M_SkipCq | Slot No.(1to 32) | A value of 1 is input if execution of an instruction is skipped as a result of executing the line that includes the last executed Skip command, otherwise a value of 0 is input. | R | Integer type |
| M_Acl | Slot No.(1to 32) | Current specified acceleration rate (%) | R | Single-precision real number type, % |
| M_DAcI | Slot No.(1to 32) | Current specified deceleration rate (%) | R | Single-precision real number type, % |
| M_NAcI | Slot No.(1to 32) | System default value (default value of M_Acl) (%) | R | Single-precision real number type, % |
| M_NDAcl | Slot No.(1to 32) | System default value (default value of M_DAcI) (%) | R | Single-precision real number type, % |
| M_AclSts | Slot No.(1to 32) | Current acceleration/deceleration status 0 = Stopped, 1 = Accelerating, 2 = Constant speed, 3=Decelerating | R | Integer type |
| M_Run | Slot No.(1to 32) | Operation status (1: Operating, 0: Not operating) | R | Integer type |
| M_Wai | Slot No.(1to 32) | Pause status (1: Pausing, 0: Not pausing) | R | Integer type |
| M_Psa | Slot No.(1to 32) | Specifies whether or not the program selection is possible in the specified task slot. (1: Selection possible, 0: Selection not possible, in pause status) | R | Integer type |
| M_Cys | Slot No.(1to 32) | Cycle operation status (1: Cycle operation, 0: Non-cycle operation) | R | Integer type |
| M_Cstp | None | Cycle stop operation status (1: Cycle stop, 0: Not cycle stop) | R | Integer type |
| C_Prg | Slot No.(1to 32) | Execution program name | R | Character string type |
| M_Line | Slot No.(1to 32) | Currently executed line No. | R | Integer type |
| M_Err | None | Error occurring (1: An error has occurred, 0: No errors have occurred) | R | Integer type |
| M_ErrLvl | None | Reads an error level. caution/low/high1/high2 = 1/2/3/4 | R | Integer type |
| M_Errno | None | Reads an error number. | R | Integer type |

8. User Mechanism Settings, Operation, and Commands

| Variable name | Array designation Note1) | Details | Attribute Note2) | Data type, Unit |
|---------------|-----------------------------|-------------------------------------------------------------------------------------------------------------------------------------------------------------------------------------|---------------------|-----------------------------------|
| M_Svo | Mechanism No.(1 to 3) | Servo motor power on (1: Servo power on, 0: Servo power off) | R | Integer type |
| M_Uar | Mechanism No.(1 to 3) | Bit data. (1: Within user specified area, 0: Outside user specified area) (Bit 0: area 1 to Bit 7: area 8) | R | Integer type |
| M_In | Input No.(0 to 32767) | Use this variable when inputting external input signals (bit units). General-purpose bit device: bit signal input 0=off 1=on The signal numbers will be 6000s for CC-Link | R | Integer type |
| M_Inb | Input No.(0 to 32767) | Use this variable when inputting external input signals (8-bit units) General-purpose bit device: byte signal input The signal numbers will be 6000s for CC-Link | R | Integer type |
| M_Inw | Input No.(0 to 32767) | Use this variable when inputting external input signals (16-bit units) General-purpose bit device: word signal input The signal numbers will be 6000s for CC-Link | R | Integer type |
| M_Out | Output No.(0 to 32767) | Use this variable when inputting external output signals (bit units). General-purpose bit device: bit signal input 0=off 1=on The signal numbers will be 6000s for CC-Link | RW | Integer type |
| M_Outb | Output No.(0 to 32767) | Use this variable when inputting external output signals (8-bit units) General-purpose bit device: byte signal input The signal numbers will be 6000s for CC-Link | RW | Integer type |
| M_Outw | Output No.(0 to 32767) | Use this variable when inputting external output signals (16-bit units) General-purpose bit device: word signal input The signal numbers will be 6000s for CC-Link | RW | Integer type |
| M_DIn | Input No.(from 6000) | CC-Link's remote register: Input register | R | Integer type |
| M_DOut | Output No.(from 6000) | CC-Link's remote register: output register | RW | Integer type |
| M_HndCq | Input No.(1 to 8) | Returns a hand check input signal. | R | Integer type |
| P_Safe | Mechanism No.(1 to 3) | Returns a safe point position. | R | Position type |
| C_Mecha | Slot No.(1 to 32) | Returns the type name of the robot. | R | Character string type |
| C_Maker | None | Shows manufacturer information (a string of up to 64 characters). | R | Character string type |
| C_User | None | Returns the content of the parameter "US-ERMSG."(a string of up to 64 characters). | R | Character string type |
| C_Date | None | Current date expressed as "year/month/date". | R | Character string type |
| C_Time | None | Current time expressed as "time/minute/second". | R | Character string type |
| M_BTime | None | Returns the remaining battery capacity time (hours). | R | Integer type, Time |
| M_Timer | Timer No. (1 to 8) | Constantly counting. Value can be set. [ms] It is possible to measure the precise execution time by using this variable in a program. | RW | Single-precision real number type |
| P_Zero | None | A variable whose position coordinate values (X, Y, Z, A, B, C, FL1, FL2) are all 0 | R | Position type |
| M_Pi | None | Circumference rate (3.1415...) | R | Double-precision real number type |

8. User Mechanism Settings, Operation, and Commands

| Variable name | Array designation Note1) | Details | Attribute Note2) | Data type, Unit |
|---------------|-----------------------------|----------------------------------------|---------------------|-----------------------------------|
| M_Exp | None | Base of natural logarithm (2.71828...) | R | Double-precision real number type |
| M_G | None | Specific gravity constant (9.80665) | R | Double-precision real number type |
| M_On | None | 1 is always set | R | Integer type |
| M_Off | None | 0 is always set | R | Integer type |

Note1) Mechanism No.1 to 3, Specifies a mechanism number corresponding to the multitask processing function.

Slot No.1 to 32, Specifies a slot number corresponding to the multitask function.

Input No.0 to 32767: (theoretical values). Specifies a bit number of an input signal.

Output No.0 to 32767: (theoretical values). Specifies a bit number of an output signal.

Note2) ROnly reading is possible.

RWBoth reading and writing are possible.

8. User Mechanism Settings, Operation, and Commands

(2) Built-in functions that operate without any problem in the user mechanism

| Class | Function name (format) | Functions | Result |
|------------------------------------|-----------------------------------------------------------------------|------------------------------------------------------------------------------------------------------------------------------------------------------------------------------------------------------|---------------|
| Numeric functions | Abs (<Numeric expression>) | Produces the absolute value | Numeric value |
| | CInt (<Numeric expression>) | Rounds off the decimal value and converts into an integer. | |
| | Deg (<Numeric expression:radian>) | Converts the angle unit from radian (rad) to degree (deg). | |
| | Exp (<Numeric expression>) | Calculates the value of the expression's exponential function | |
| | Fix (<Numeric expression>) | Produces an integer section | |
| | Int (<Numeric expression>) | Produces the largest integer that does not exceed the value in the expression. | |
| | Len(<Character string expression>) | Produces the length of the character string. | |
| | Ln (<Numeric expression>) | Produces the logarithm. | |
| | Log (<Numeric expression>) | Produces the common logarithm. | |
| | Max (<Numeric expression>...) | Obtains the maximum value from a random number of arguments. | |
| | Min (<Numeric expression>...) | Obtains the minimum value from a random number of arguments. | |
| | Rad (<Numeric expression: deg.>) | Converts the angle unit from radian (rad) to degree (deg). | |
| | Sgn (<Numeric expression>) | Checks the sign of the number in the expression | |
| | Sqr (<Numeric expression>) | Calculates the square root | |
| | Strpos (<Character string expression>, <Character string expression>) | Obtains the 2nd argument character string position in the 1st argument character string. | |
| | Rnd (<Numeric expression>) | Produces the random numbers. | |
| | Asc(<Character string expression>) | Provides a character code for the first character of the character string in the expression. | |
| | Cvi(<Character string expression>) | Converts a 2-byte character string into integers. | |
| | Cvs(<Character string expression>) | Converts a 4-byte character string into a single-precision real number. | |
| | Cvd(<Character string expression>) | Converts an 8-byte character string into a double-precision real number. | |
| Val(<Character string expression>) | Converts a character string into a numeric value. | | |
| Trigonometric functions | Atn(<Numeric expression>) | Calculates the arc tangent. Unit: radian Definition range: Numeric value, Value range: $-\pi/2$ to $+\pi/2$ | Numeric value |
| | Atn2(<Numeric expression>, <Numeric expression>) | Calculates the arc tangent. Unit: radian $\theta = \text{Atn2}(\Delta y, \Delta x)$ Definition range: Numeric value of Δy or Δx that is not 0 Value range: $-\pi$ to $+\pi$ | |
| | Cos(<Numeric expression>) | Calculates the cosine Unit: radian Definition range: Numeric value range, Value range: -1 to +1 | |
| | Sin(<Numeric expression>) | Calculates the sine Unit: radian Definition range: Numeric value range, Value range: -1 to +1 | |
| | Tan(<Numeric expression>) | Calculates the tangent. Unit: radian Definition range: Numeric value range, Value range: Range of numeric value | Numeric value |

8. User Mechanism Settings, Operation, and Commands

| Class | Function name (format) | Functions | Result |
|----------------------------|-----------------------------------------------------------------------------------|------------------------------------------------------------------------------------------------------------------------------------------------------------------------------------------------------------------------------------------------------------------------------------------------------------------------------------------------------------------------------------------------------------------------------------------------------|------------------|
| Character string functions | Bin\$(<Numeric expression>) | Converts numeric expression value into binary character string. | Character string |
| | Chr\$(<Numeric expression>) | Provides character having numeric expression value character code. | |
| | Hex\$(<Numeric expression>) | Converts numeric expression value into hexadecimal character string. | |
| | Left\$(<Character string expression>, <Numeric expression>) | Obtains character string having length designated with 2nd argument from left side of 1st argument character string. | |
| | Mid\$(<Character string expression>, <Numeric expression>, <Numeric expression>) | Obtains character string having length designated with 3rd argument from the position designated with the 2nd argument in the 1st argument character string. | |
| | Mirror\$(<Character string expression>) | Mirror reversal of the character string binary bit is carried out. | |
| | MKi\$(<Numeric expression>) | Converts numeric expression value into 2-byte character string. | |
| | MKs\$(<Numeric expression>) | Converts numeric expression value into 4-byte character string. | |
| | MKd\$(<Numeric expression>) | Converts numeric expression value into 8-byte character string. | |
| | Right\$(<Character string expression>, <Numeric expression>) | Obtains character string having length designated with 2nd argument from right side of 1st argument character string. | |
| | Str\$(<Numeric expression>) | Converts the numeric expression value into a decimal character string. | |
| | CkSum (<Character string expression>, <Numeric expression>, <Numeric expression>) | Creates the checksum of a character string. Returns the value of the lower byte obtained by adding the character value of the second argument position to that of the third argument position, in the first argument character string. | Numeric value |
| Position variables | Inv(<Position>) | Obtains the reverse line. | Position |
| | PtoJ(<Position>) | Converts the position data into joint data. | Joint |
| | JtoP(<Position>) | Converts the joint data into position data. | Position |
| | Zone(<Position 1>, <Position 2>, <Position 3>) | Checks whether position 1 is within the space (Cube) created by the position 2 and position 3 points. Outside the range=0, Within the range=1 For position coordinates that are not checked or non-existent, the following values should be assigned to the corresponding position coordinates: If the unit is degrees, assign -360 to position 2 and 360 to position 3 If the unit is mm, assign -10000 to position 2 and 10000 to position 3 | Numeric value |

(3) Instructions related to movement control that operate without any problem in the user mechanism

| Command | Explanation |
|------------------------|---------------------------------------------------------|
| Mov(Move) | Joint interpolation |
| Mva(Move Arch) | Arch motion interpolation |
| Ovrd(Override) | Overall speed specification |
| JOvrd(J Override) | Speed specification during joint interpolation movement |
| Cnt (Continuous) | Continuous path mode specification |
| Accel (Accelerate) | Acceleration/deceleration rate specification |
| Jrc(Joint Roll Change) | Enables multiple rotation of the tip axis |

8. User Mechanism Settings, Operation, and Commands

| Command | Explanation |
|----------------|------------------------------------------------------------|
| Fine(Fine) | Robot's positioning range specification |
| Servo(Servo) | Servo motor power ON/OFF |
| Wth(With) | Addition instruction of movement instruction |
| WthIf(With If) | Additional conditional instruction of movement instruction |

(4) Instructions related to program control that operate without any problem in the user mechanism

| Command | Explanation |
|--------------------------------------------------------|-----------------------------------------------------|
| If...Then...Else...EndIf(If Then Else) | Conditional branching |
| Select Case | Enables multiple branching |
| GoTo(Go To) | Jump |
| GoSub (RETURN) (Go Subroutine) | Subroutine jump |
| Reset Err(Reset Error) | Resets an error (use of default is not allowed) |
| CallP(Call P) | Program call |
| FPrm(FPRM) | Program call argument definition |
| Dly(Delay) | Timer |
| Hlt(Halt) | Suspends a program |
| End(End) | End a program |
| On...GoSub(ON Go Subroutine) | Subroutine jump according to the value |
| On...GoTo(On Go To) | Jump according to the value |
| For - Next (For-next) | Repeat |
| While-Wend(While End) | Conditional repeat |
| Open(Open) | Opens a file or communication line |
| Print(Print) | Outputs data |
| Input(Input) | Inputs data |
| Close(Close) | Closes a file or communication line |
| Com On/Com Off/Com Stop (Communication ON/OFF/STOP) | Enables, disables or pauses communication interrupt |
| On Com GuSub (ON Communication Go Subroutine) | Communication interrupt subroutine jump |
| HOpen / HClose(Hand Open/Hand Close) | Hand's open/close |
| Error(error) | User error |
| Skip(Skip) | Skip while moving |
| Wait(Wait) | Waiting for conditions |
| Clr(Clear) | Signal clear |

(5) Definition instructions that operate without any problem in the user mechanism

| Command | Explanation |
|----------------------------------------------------------------|--------------------------------------------|
| Dim(Dim) | Array variable declaration |
| Def Plt(Define pallet) | Pallet declaration |
| Plt(Pallet) | Pallet position calculation |
| Def Act(Define act) | Interrupt definition |
| Act(Act) | Starts or ends interrupt monitoring |
| Def Jnt(Define Joint) | Joint type position variable definition |
| Def Pos(Define Position) | XYZ type position variable definition |
| Def Inte/Def Float/Def Double (Define Integer/Float/Double) | Integer or real number variable definition |
| Def Char(Define Character) | Character variable definition |

8. User Mechanism Settings, Operation, and Commands

| Command | Explanation |
|-------------------------|-----------------------------|
| Def IO(Define IO) | Signal variable definition |
| Def FN(Define function) | User function definition |
| Tool(Tool) | Hand length setting |
| Base(Base) | Robot base position setting |

(6) Multi-tasks that operate without any problem in the user mechanism

| Command | Explanation |
|--------------------------|-----------------------------------------------------------------|
| XLoad(X Load) | Loads a program to another task slot |
| XRun (X Run) | Execute the program in another task slot |
| XStp(X Stop) | Stop the program in another task slot |
| XRst(X Reset) | Resets the program in another task slot being suspended |
| XClr(X Clear) | Cancels the loading of the program from the specified task slot |
| GetM (Get Mechanism) | Obtains mechanical control right |
| RelM (Release Mechanism) | Releases mechanical control right |
| Priority(Priority) | Changes the task slot priority |
| Reset Err(Reset Error) | Resets an error (use of default is not allowed) |

8.6.3 Limitation when using user mechanism

When using the addition axis as a user mechanism, the robot arm has the following limitation.

- The collision detection function and the interference avoidance function cannot be used.
- The control cycle of the robot controller becomes twice as long as that of the standard robot.

And also, the user mechanism does not correspond to the collision detection function and the interference avoidance function.

8. User Mechanism Settings, Operation, and Commands

8.7 Example of System Configuration of the User Mechanism

This section shows an example of system configuration using the additional axis interface.

8.7.1 Rotation table system

- System Overview

This example shows a system using a standard robot and a rotary table in which the rotary table functions as a multi-mechanism (controlled asynchronously with the robot arm).

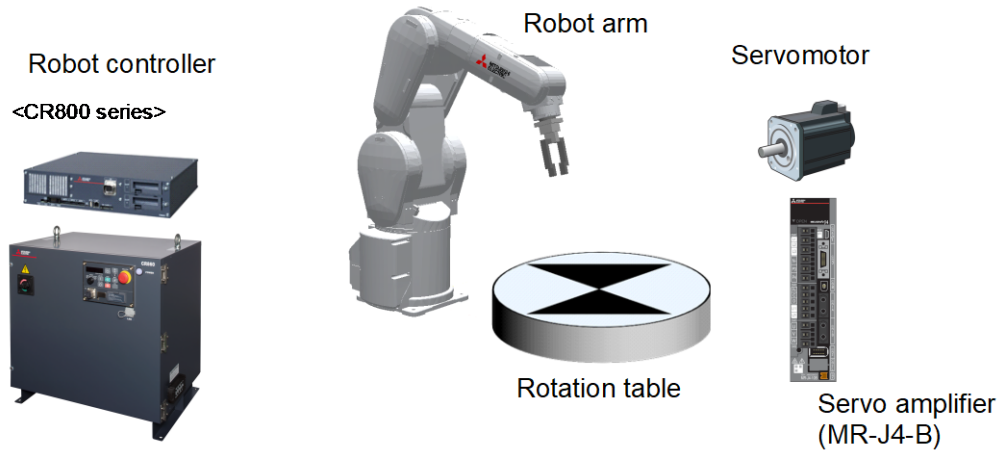

Note) The fig of the robot arm is the vertical multi-joint type 6 axis robot's example.

Fig. 8.7.1 Rotation table system

Table 8.7.1 Structural equipment

| | |
|------------------|----------------------------------------|
| Robot arm | Vertical 6-axis robot |
| Robot controller | CR800 series controller |
| Servo amplifier | Prepared by the customer. |
| Servo motor | Prepared by the customer. |
| Rotation table | Manufactured and prepared by customer. |

Table 8.7.2 Rotation axis specification

| | |
|--------------------------------------------------|---------------------------------------------------------------|
| Control axis number of servo | 1st |
| Number of mechanisms and number of axis | 1 mechanism and 1 axis |
| Unit of additional axis | degree (rotation axis) |
| Rotation direction of additional axis | Forward run (CCW) |
| Acceleration/deceleration of the additional axis | 0.4 seconds per each |
| Total speed ratio of additional axis | 1/20 (1/20 rotation of additional axis per rotation of motor) |
| Rated speed | 3000 (rpm) |
| Maximum speed | 4000 (rpm) |
| Encoder resolution | 4194304 (pulse/rev) |
| Operating range | -160 to +160 (degree) |
| Origin designated by user | 90 (degree) |

- Connecting devices

Devices are connected as follows.

- (1) Connect servo amplifier (CN1A connector) with the robot controller by the SSCNETIII cable. Connect the robot controller with the AXIS connector. (Refer to "5.1 Connection of Robot CPU and servo amplifier" in this manual.)
- (2) Set the axis selection rotary switch (SW1) of the servo amplifier to "0". (Refer to "6.1 Servo amplifier setting" in this manual.)
- (3) Connect the servo amplifier and the servo motor. (Refer to "5.4 Connection example of servo amplifier and servo motor.")

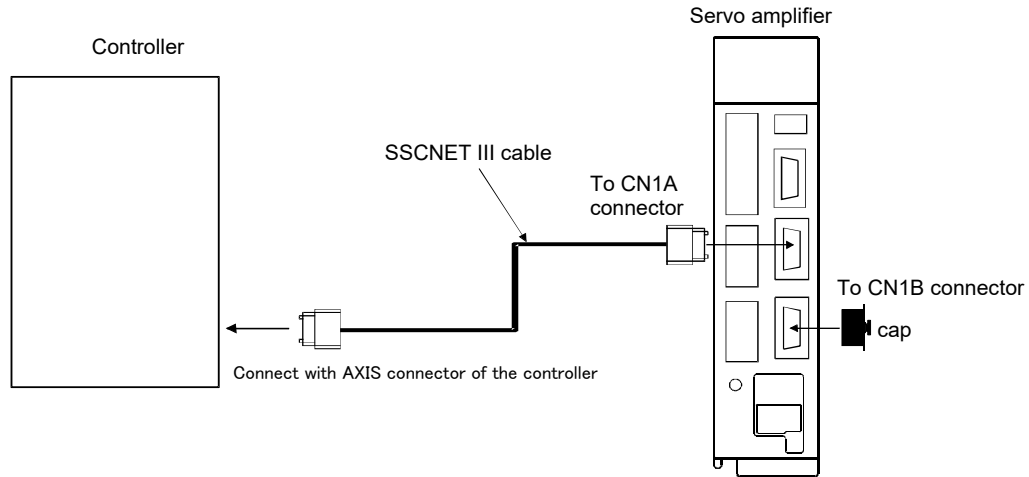

Fig. 8.7.2 Connection of controller and servo amplifier

⚠ CAUTION

Please install the connector cap to the connector for communication which does not connect the SSCNETIII cable. There is a possibility of malfunctioning if the cap is not installed. And, if the light from the connector for communication hits upon the eyes, there is a possibility of feeling the incompatibility for the eyes.

- Setting the servo amplifier parameters

Set the servo amplifier parameters by refer to "6.2 Parameter setting of servo amplifier."

8. User Mechanism Settings, Operation, and Commands

- Setting the robot controller parameters

Set the parameters related to the system configuration of the robot controller.

For details on how to set these parameters, refer to separate "Instruction Manual/ Detailed explanations of functions and operations".

Table 8.7.3 Setting the rotation table system parameters

| Parameter name changed | Before/after change | Value of parameter |
|-----------------------------|---------------------|----------------------------------------------------------------------------------------------------------------------------------------------------------------------------|
| AXUNUM | Before | 0 |
| | After | 1 |
| AXMENO | Before | 0, 0, 0, 0, 0, 0, 0, 0, 0, 0, 0, 0, 0, 0, 0, 0 |
| | After | 2 , 0, 0, 0, 0, 0, 0, 0, 0, 0, 0, 0, 0, 0, 0, 0 |
| AXJNO | Before | 0, 0, 0, 0, 0, 0, 0, 0, 0, 0, 0, 0, 0, 0, 0, 0 |
| | After | 1 , 0, 0, 0, 0, 0, 0, 0, 0, 0, 0, 0, 0, 0, 0, 0 |
| AXUNT | Before | 0, 0, 0, 0, 0, 0, 0, 0, 0, 0, 0, 0, 0, 0, 0, 0 |
| | After | 0, 0, 0, 0, 0, 0, 0, 0, 0, 0, 0, 0, 0, 0, 0, 0 |
| AXSPOL | Before | 0, 0, 0, 0, 0, 0, 0, 0, 0, 0, 0, 0, 0, 0, 0, 0 |
| | After | 0, 0, 0, 0, 0, 0, 0, 0, 0, 0, 0, 0, 0, 0, 0, 0 |
| AXACC | Before | 0.20, 0.20, 0.20, 0.20, 0.20, 0.20, 0.20, 0.20, 0.20, 0.20, 0.20, 0.20, 0.20, 0.20, 0.20, 0.20 |
| | After | 0.40 , 0.20, 0.20, 0.20, 0.20, 0.20, 0.20, 0.20, 0.20, 0.20, 0.20, 0.20, 0.20, 0.20, 0.20, 0.20 |
| AXDEC | Before | 0.20, 0.20, 0.20, 0.20, 0.20, 0.20, 0.20, 0.20, 0.20, 0.20, 0.20, 0.20, 0.20, 0.20, 0.20, 0.20 |
| | After | 0.40 , 0.20, 0.20, 0.20, 0.20, 0.20, 0.20, 0.20, 0.20, 0.20, 0.20, 0.20, 0.20, 0.20, 0.20, 0.20 |
| AXGRTN | Before | 1, 1, 1, 1, 1, 1, 1, 1, 1, 1, 1, 1, 1, 1, 1, 1 |
| | After | 1, 1, 1, 1, 1, 1, 1, 1, 1, 1, 1, 1, 1, 1, 1, 1 |
| AXGRTD | Before | 10, 10, 10, 10, 10, 10, 10, 10, 10, 10, 10, 10, 10, 10, 10, 10 |
| | After | 20 , 10, 10, 10, 10, 10, 10, 10, 10, 10, 10, 10, 10, 10, 10, 10 |
| AXMREV | Before | 2000, 2000, 2000, 2000, 2000, 2000, 2000, 2000, 2000, 2000, 2000, 2000, 2000, 2000, 2000, 2000 |
| | After | 3000 , 2000, 2000, 2000, 2000, 2000, 2000, 2000, 2000, 2000, 2000, 2000, 2000, 2000, 2000, 2000 |
| AXJMX | Before | 3000, 3000, 3000, 3000, 3000, 3000, 3000, 3000, 3000, 3000, 3000, 3000, 3000, 3000, 3000, 3000 |
| | After | 4000 , 3000, 3000, 3000, 3000, 3000, 3000, 3000, 3000, 3000, 3000, 3000, 3000, 3000, 3000, 3000 |
| AXENCR | Before | 4194304, 4194304, 4194304, 4194304, 4194304, 4194304, 4194304, 4194304, 4194304, 4194304, 4194304, 4194304, 4194304, 4194304, 4194304, 4194304 |
| | After | 4194304, 4194304, 4194304, 4194304, 4194304, 4194304, 4194304, 4194304, 4194304, 4194304, 4194304, 4194304, 4194304, 4194304, 4194304, 4194304 |
| MEJAR (Mechanism No.2) | Before | -80000.00, 80000.00, -80000.00, 80000.00, -80000.00, 80000.00, -80000.00, 80000.00, -80000.00, 80000.00, -80000.00, 80000.00, -80000.00, 80000.00, -80000.00, 80000.00 |
| | After | -160.00, 160.00 , -80000.00, 80000.00, -80000.00, 80000.00, -80000.00, 80000.00, -80000.00, 80000.00, -80000.00, 80000.00, -80000.00, 80000.00, -80000.00, 80000.00 |
| USERORG (Mechanism No.2) | Before | 0.0, 0.0, 0.0, 0.0, 0.0, 0.0, 0.0, 0.0 |
| | After | 90.0 , 0.0, 0.0, 0.0, 0.0, 0.0, 0.0, 0.0 |

• Program example

(1) Details of work

In this system, a standard robot unloads a work from a rotary axis (position "<1>") and transports it to a station (position "<2>").

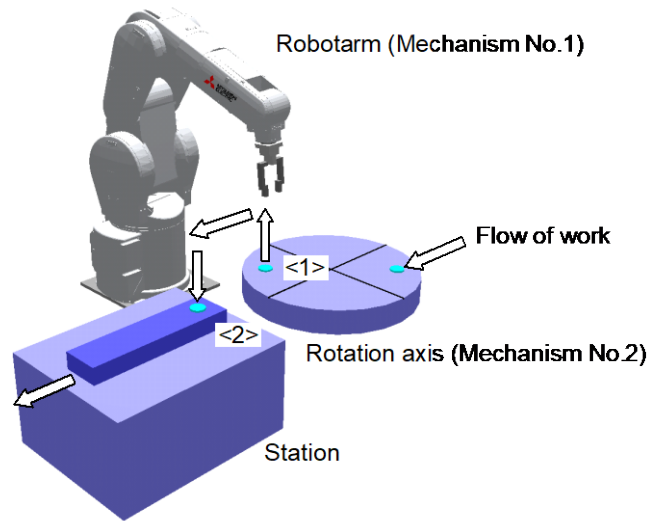

• Flow of work

- (i) A work is transported to rotation axis from the external location.
- (ii) The rotary axis rotates and transports a work to the position from which the robot unloads the work.
- (iii) The robot unloads the work from the rotary axis and transports the work to the station.
- (iv) The work is transported from the station to the external location.

(2) Robot Program Structure

Provide one robot program for each mechanism, as shown below

| Program name | Explanation |
|--------------|--------------------------------------|
| 1 | Operation program of standard robots |
| 2 | Operation program of rotation axis |

8. User Mechanism Settings, Operation, and Commands

(3) Input/Output signal

The general I/O signals to be used are as follows

| General purpose input/output name | Signal H/L | Explanation |
|-----------------------------------|------------|-----------------------------------------------------------------------------------|
| General purpose input 10080 | H (1) | Transport of works from the external location to rotation axis has been complete. |
| | L (0) | Work not transported from the external location to the rotary axis. |

| General purpose input/output name | Signal H/L | Explanation |
|-----------------------------------|------------|-----------------------------------------------------------------------------------|
| General purpose output 10080 | H (1) | Transport of works from the external location to rotation axis has been complete. |
| | L (0) | Work not transported from the external location to the rotary axis. |

(4) Position variable

The position data is as follows

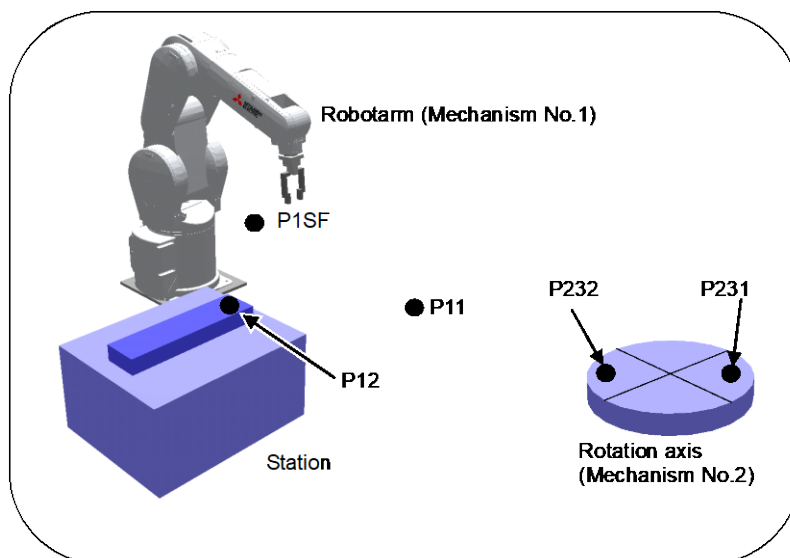

| Mechanism name | Position variable name | Explanation |
|-----------------------------------|------------------------|---------------------------------------------------------------------------------|
| Robot arm (Mechanism No.1) | P1SF | Safe position |
| | P11 | Position where works are unloaded from rotation axis (Mechanism No.2) |
| | P12 | Position where works are loaded to station. |
| Rotation axis (Mechanism No.2) | P231 | Position to which the work is to be transported |
| | P232 | Position from which the standard robot (mechanism number 1) unloads the work |

(5) Program External Variables

Program external variables are used as interlock variables between mechanisms.
The following variables are used.

| Variable name | Variable (0/1) | Explanation |
|---------------|----------------|--------------------------------------------------------|
| M_01 | 0 | Preparation of work on rotary axis incomplete |
| | 1 | Preparation of work on rotary axis complete |
| M_02 | 0 | Unloading of work by robot from rotary axis incomplete |
| | 1 | Unloading of work by robot from rotary axis complete |

The following flow illustrates only the interlock between mechanisms:

Note that programs 1 and 2 in the diagram start simultaneously. (Refer to "Procedure 2: Setting the task slot parameter " in "(6) Procedure up to program execution.")

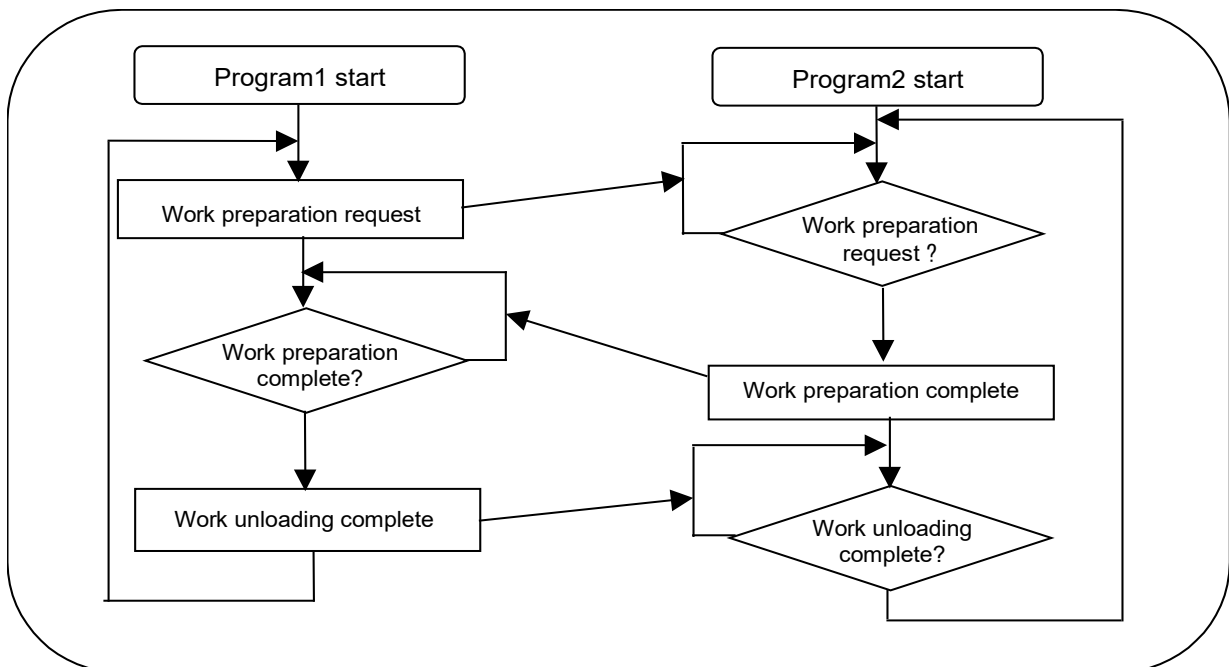

8. User Mechanism Settings, Operation, and Commands

(6) Procedure up to program execution

Procedure 1 : Program creation

<1>Program of mechanism number 1 (Program name:1)

| | |
|------------------------------|------------------------------------------------------------------|
| 100 GetM 1 | ' Gets mechanism 1 |
| 110 M_01#=0 | ' Interlock variable is initialized |
| 120 *LOOP | |
| 130 M_01#=1 | ' Requests for preparation of work on rotary axis |
| 140 If M_01#=1 Then GoTo 140 | ' Waits for completion of preparation of work on rotary axis |
| 150 Mov P11,-50 | ' Moves to 50 mm above P11 |
| 160 Mvs P11 | ' Moves to position from which work is unloaded from rotary axis |
| 170 HClose 1 | ' Pickup work piece |
| 180 Dly 0.5 | ' Waits for 0.5 sec |
| 190 Mvs P11,-50 | ' Moves to 50 mm above P11 |
| 200 M_02#=1 | ' Unloading of work from rotary axis is complete. |
| 210 Mov P12,-50 | ' Moves to 50 mm above P12 |
| 220 Mvs P12 | ' Moves work placement position of positioning device |
| 230 HOpen 1 | ' Places work |
| 240 Dly 0.5 | ' Waits for 0.5 sec |
| 250 Mva P12,-50 | ' Moves to 50 mm above P12 |
| 260 GoTo *LOOP | |

<2>Program of mechanism number 2 (Program name:2)

| | |
|---------------------------------|----------------------------------------------------------------------------|
| 100 GetM 2 | ' Gets mechanism 2 |
| 110 M_Out(11)=0 | ' Prohibits work transport to external location |
| 120 Mov P231 | ' Moves to work transport position |
| 130 Dly 0.1 | ' Waits for completion (static) of operation (set values must be adjusted) |
| 140 *LOOP | |
| 150 If M_01#=0 Then GoTo 150 | ' Waits for request of preparation of work on rotary axis |
| 160 M_Out(11)=1 | ' Permits work transport to external location |
| 170 If M_In(11)=0 Then GoTo 170 | ' Waits for completion of work transport from external location |
| 180 M_Out(11)=0 | ' Prohibits work transport to external location |
| 190 Mov P232 | ' Rotates to position where robot unload the work |
| 200 Dly 0.1 | ' Waits for completion (static) of operation (set values must be adjusted) |
| 210 M_02#=0 | ' Rotary axis requests unloading of work |
| 220 M_01#=0 | ' Preparation of work by rotary axis is complete. |
| 230 If M_02#=0 Then GoTo 230 | ' Waits for completion of unloading of work from rotary axis |
| 240 Mov P231 | ' Moves to work transport position |
| 250 GoTo *LOOP | |

Procedure 2 : Setting the task slot parameters

Set the slot parameters as follows.

| Parameters | Program name | Operation mode | Operation format | Number of executed lines |
|------------|--------------|----------------|------------------|--------------------------|
| SLT1 | 1 | REP | START | 1 |
| SLT2 | 2 | REP | START | 1 |

8. User Mechanism Settings, Operation, and Commands

The slot parameters have the format shown below.

For details refer to "Instruction Manual/ Detailed explanations of functions and operations".

SLT* = 1. Program name, 2. Operation format, 3. Starting conditions, 4. Order of priority

| Item of parameter | Default value | Setting value |
|------------------------|---------------|------------------------------------------------------------------------------------------------------|
| 1. Program name | - | Possible to set a registered program name |
| 2. Operation format | REP | REP : Continuous Operation |
| | | CYC : One cycle operation |
| 3. Starting conditions | START | START : Execution of a program using the START button on the operation panel or the I/O START signal |
| | | ALWAYS : Execution of a program when the controller's power is turned on |
| | | ERROR : Execution of a program when the controller is in error status |
| 4. Order of priority | 1 | 1 to 31: Number of lines executed at one time at multitask operation |

Procedure 3 : Reflecting the task slot parameters

Turn off the power to enable the SLT1 and SLT2 parameters, and then turn on the power again.

Procedure 4 : Starting

Run the program 1 in the OPERATION screen of the teaching pendant. When the program 1 is started, the program 2 starts its operation simultaneously.

8. User Mechanism Settings, Operation, and Commands

8.7.2 System with multiple axes

- System Overview

This example shows a system consisting of a standard robot, a vertical moving axis and a rotary axis in which the vertical moving axis and the rotary axis function as multi-mechanisms (controlled asynchronously with the robot arm).

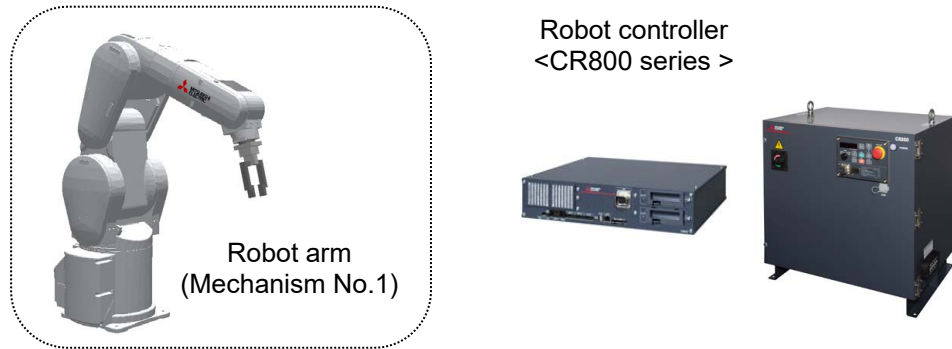

Note) The fig of the robot arm is the vertical multi-joint type 6 axis robot's example.

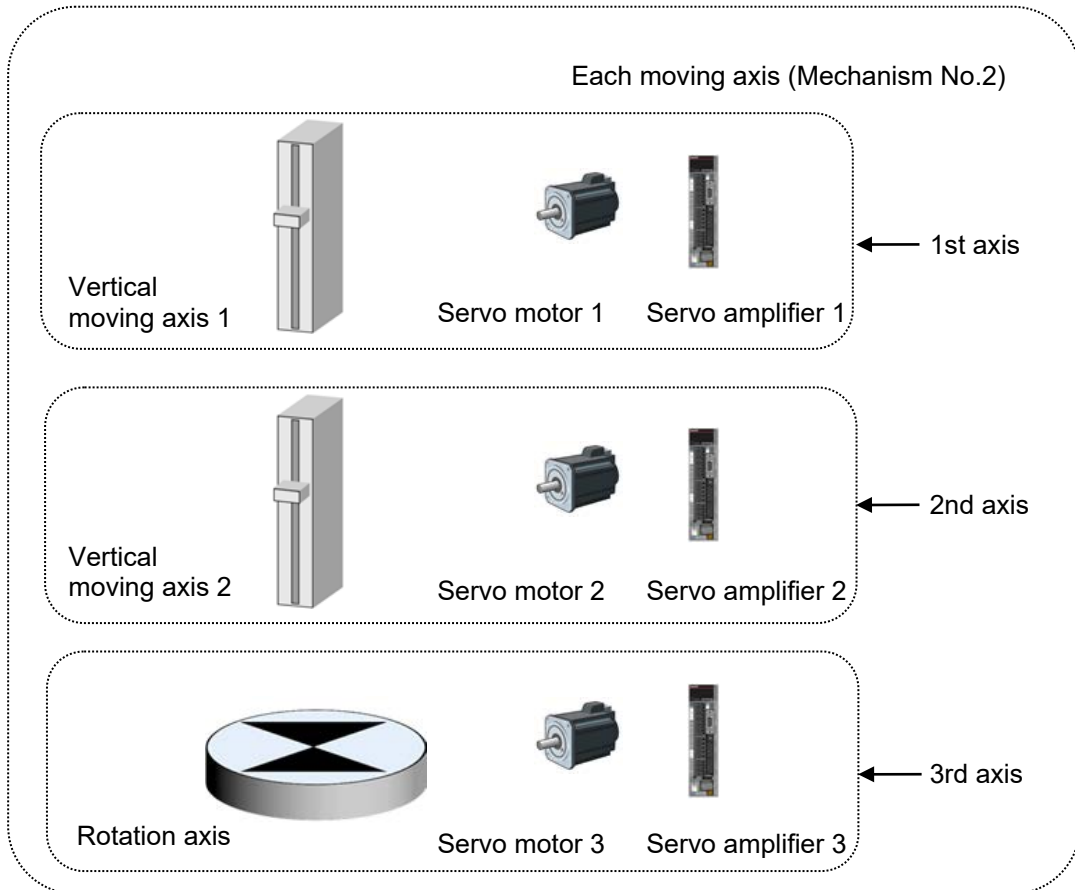

Fig. 8.7.4 System with multiple axes

8. User Mechanism Settings, Operation, and Commands

Table 8.7.3 Structural equipment

| | |
|------------------------|----------------------------------------|
| Robot arm | Vertical 6-axis robot |
| Robot controller | CR800 series controller |
| Servo amplifier | Prepared by the customer. |
| Servo motor | Prepared by the customer. |
| Vertical moving axis 1 | Manufactured and prepared by customer. |
| Vertical moving axis 2 | Manufactured and prepared by customer. |
| Rotation table | Manufactured and prepared by customer. |

Table 8.7.4 Multiple axes specifications

| | | | |
|--------------------------------------------------|----------------------------|----------------------------|------------------------------------------------------------------|
| Mechanism number | 2 | | |
| Name of mechanism | Vertical moving axis 1 | Vertical moving axis 2 | Rotation axis |
| Axis number of mechanism | 1 axis (J1) | 2 axis (J2) | 3 axis (J3) |
| Control axis number of servo | 1st | 2nd | 3rd |
| Unit of additional axis | mm (Direct moving axis) | mm (Direct moving axis) | degree (rotation axis) |
| Rotation direction of additional axis | Forward run (CCW) | | |
| Acceleration/deceleration of the additional axis | 0.4 seconds per each | | |
| Total speed ratio of additional axis | 37/2 | 37/2 | 1/20 (1/20 rotation of additional axis per rotation of motor) |
| Rated speed | 3000 (rpm) | | |
| Maximum speed | 4000 (rpm) | | |
| Encoder resolution | 4194304 (pulse/rev) | | |
| Operating range | -2000 to +3000 (mm) | -2000 to +3000 (mm) | -160 to +160 (degree) |
| Origin designated by user | 0 (mm) | 0 (mm) | 90 (degree) |

8. User Mechanism Settings, Operation, and Commands

• Connecting devices

Devices are connected as follows.

- (1) Connect servo amplifier (CN1A connector) with the robot controller by the SSCNETIII cable. Connect the robot controller with the AXIS connector. (Refer to "5.1 Connection of Robot CPU and servo amplifier" in this manual.)
- (2) Set the axis selection rotary switch (SW1) of the servo amplifier to the following: 0 for the first axis, 1 for the second axis, and 2 for the third axis closest from the robot controller. (Refer to "6.1 Servo amplifier setting" in this manual.)
- (3) Connect the servo amplifier and the servo motor. (Refer to "5.4 Connection example of servo amplifier and servo motor.")

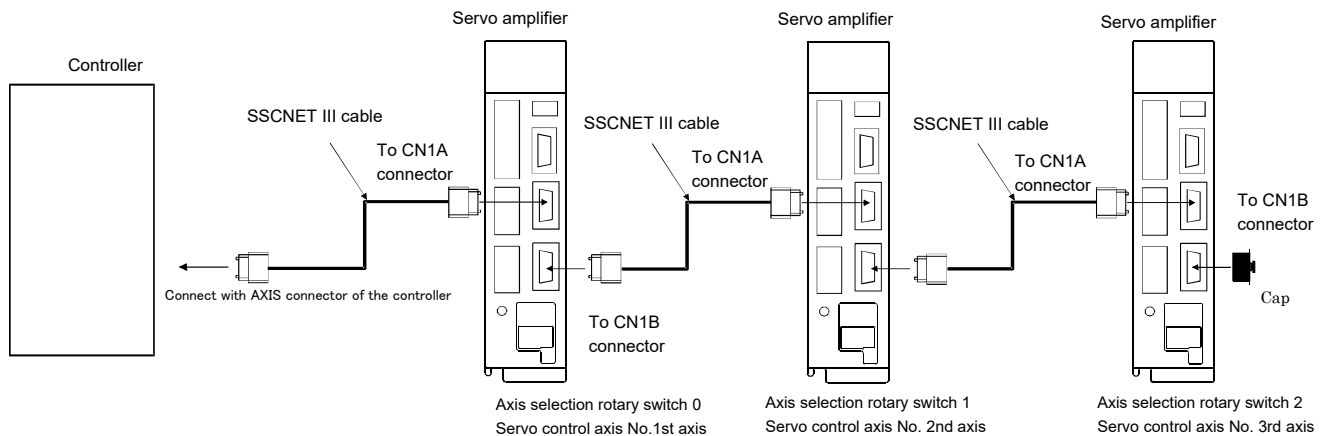

Fig. 8.7.5 Connection of controller and servo amplifier

⚠ CAUTION

Please install the connector cap to the connector for communication which does not connect the SSCNETIII cable.

There is a possibility of malfunctioning if the cap is not installed. And, if the light from the connector for communication hits upon the eyes, there is a possibility of feeling the incompatibility for the eyes.

• Setting the servo amplifier parameters

Set the servo amplifier parameters by refer to "6.2 Parameter setting of servo amplifier."

8. User Mechanism Settings, Operation, and Commands

- Setting the robot controller parameters

Set the parameters of robot controller.

For details on how to set these parameters, refer to "Instruction Manual/ Detailed explanations of functions and operations".

Table 8.7.5 Setting the multiple axes system parameters

| Parameter name changed | Before/after change | Value of parameter |
|-----------------------------|---------------------|------------------------------------------------------------------------------------------------------------------------------------------------------------------------|
| AXUNUM | Before | 0 |
| | After | 1 |
| AXMENO | Before | 0, 0, 0, 0, 0, 0, 0, 0, 0, 0, 0, 0, 0, 0, 0, 0 |
| | After | 2, 2, 2 , 0, 0, 0, 0, 0, 0, 0, 0, 0, 0, 0, 0, 0 |
| AXJNO | Before | 0, 0, 0, 0, 0, 0, 0, 0, 0, 0, 0, 0, 0, 0, 0, 0 |
| | After | 1, 2, 3 , 0, 0, 0, 0, 0, 0, 0, 0, 0, 0, 0, 0, 0 |
| AXUNT | Before | 0, 0, 0, 0, 0, 0, 0, 0, 0, 0, 0, 0, 0, 0, 0, 0 |
| | After | 1, 1 , 0, 0, 0, 0, 0, 0, 0, 0, 0, 0, 0, 0, 0, 0 |
| AXSPOL | Before | 0, 0, 0, 0, 0, 0, 0, 0, 0, 0, 0, 0, 0, 0, 0, 0 |
| | After | 0, 0, 0, 0, 0, 0, 0, 0, 0, 0, 0, 0, 0, 0, 0, 0 |
| AXACC | Before | 0.20, 0.20, 0.20, 0.20, 0.20, 0.20, 0.20, 0.20, 0.20, 0.20, 0.20, 0.20, 0.20, 0.20, 0.20, 0.20 |
| | After | 0.40, 0.40, 0.40 , 0.20, 0.20, 0.20, 0.20, 0.20, 0.20, 0.20, 0.20, 0.20, 0.20, 0.20, 0.20, 0.20 |
| AXDEC | Before | 0.20, 0.20, 0.20, 0.20, 0.20, 0.20, 0.20, 0.20, 0.20, 0.20, 0.20, 0.20, 0.20, 0.20, 0.20, 0.20 |
| | After | 0.40, 0.40, 0.40 , 0.20, 0.20, 0.20, 0.20, 0.20, 0.20, 0.20, 0.20, 0.20, 0.20, 0.20, 0.20, 0.20 |
| AXGRTN | Before | 1, 1, 1, 1, 1, 1, 1, 1, 1, 1, 1, 1, 1, 1, 1, 1 |
| | After | 37, 37 , 1, 1, 1, 1, 1, 1, 1, 1, 1, 1, 1, 1, 1, 1 |
| AXGRTD | Before | 10, 10, 10, 10, 10, 10, 10, 10, 10, 10, 10, 10, 10, 10, 10, 10 |
| | After | 2, 2, 20 , 10, 10, 10, 10, 10, 10, 10, 10, 10, 10, 10, 10, 10 |
| AXMREV | Before | 2000, 2000, 2000, 2000, 2000, 2000, 2000, 2000, 2000, 2000, 2000, 2000, 2000, 2000, 2000, 2000 |
| | After | 3000, 3000, 3000 , 2000, 2000, 2000, 2000, 2000, 2000, 2000, 2000, 2000, 2000, 2000, 2000, 2000 |
| AXJMX | Before | 3000, 3000, 3000, 3000, 3000, 3000, 3000, 3000, 3000, 3000, 3000, 3000, 3000, 3000, 3000, 3000 |
| | After | 4000, 4000, 4000 , 3000, 3000, 3000, 3000, 3000, 3000, 3000, 3000, 3000, 3000, 3000, 3000, 3000 |
| AXENCR | Before | 4194304, 4194304, 4194304, 4194304, 4194304, 4194304, 4194304, 4194304, 4194304, 4194304, 4194304, 4194304, 4194304, 4194304, 4194304, 4194304 |
| | After | 4194304, 4194304, 4194304, 4194304, 4194304, 4194304, 4194304, 4194304, 4194304, 4194304, 4194304, 4194304, 4194304, 4194304, 4194304, 4194304 |
| MEJAR (Mechanism No.2) | Before | -80000.00, 80000.00, -80000.00, 80000.00, -80000.00, 80000.00, -80000.00, 80000.00, -80000.00, 80000.00, -80000.00, 80000.00, -80000.00, 80000.00, -80000.00, 80000.00 |
| | After | -2000.00, 3000.00, -2000.00, 3000.00, -160.00, 160.00 , -80000.00, 80000.00, -80000.00, 80000.00, -80000.00, 80000.00, -80000.00, 80000.00, -80000.00, 80000.00 |
| USERORG (Mechanism No.2) | Before | 0.0, 0.0, 0.0, 0.0, 0.0, 0.0, 0.0, 0.0 |
| | After | 0.0, 0.0, 90.0 , 0.0, 0.0, 0.0, 0.0, 0.0 |

8. User Mechanism Settings, Operation, and Commands

- Program example

(1) Details of work

In this system, works are transported between the standard robot and the rotary axis by utilizing interlock. Each mechanism repeats the following operation.

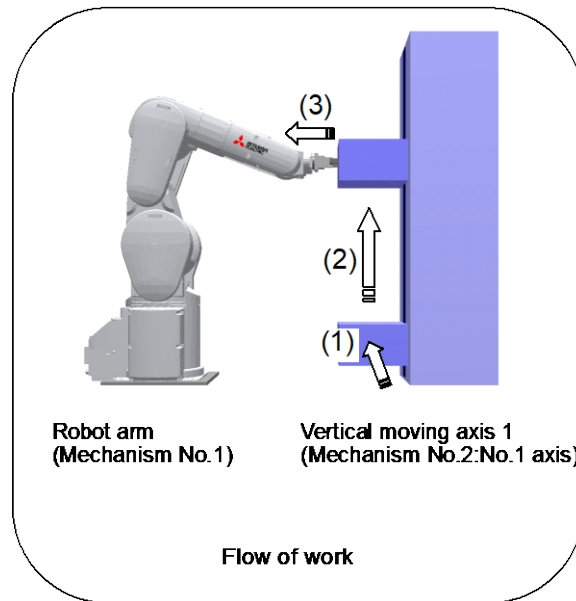

- Flow of work

- A work is transported to the vertical moving axis 1.
- The vertical moving axis 1 raises and transports the work to the position from which the standard robot unloads the work.
- The standard robot unloads the work from the vertical moving axis 1.

(2) Robot Program Structure

Provide one robot program for each mechanism, as shown below

| Program name | Explanation |
|--------------|--------------------------------------|
| 1 | Operation program of standard robots |
| 2 | Operation program of mechanism No.2. |

(3) Input/Output signal

The general I/O signals to be used are as follows

| General purpose input/output name | Signal H/L | Explanation |
|-----------------------------------|------------|--------------------------------------------------------------------------------------------|
| General purpose input 10081 | H (1) | Transport of works from the external location to vartical moving axis 1 has been complete. |
| | L (0) | Work not transported from the external location to the vartical moving axis 1. |

| General purpose input/output name | Signal H/L | Explanation |
|-----------------------------------|------------|------------------------------------------------|
| General purpose output 10080 | H (1) | Places workpiece |
| | L (0) | Pickup workpiece |
| General purpose output 10081 | H (1) | Permits work transport to external location. |
| | L (0) | Prohibits work transport to external location. |

(4) Position variable

The position data is as follows

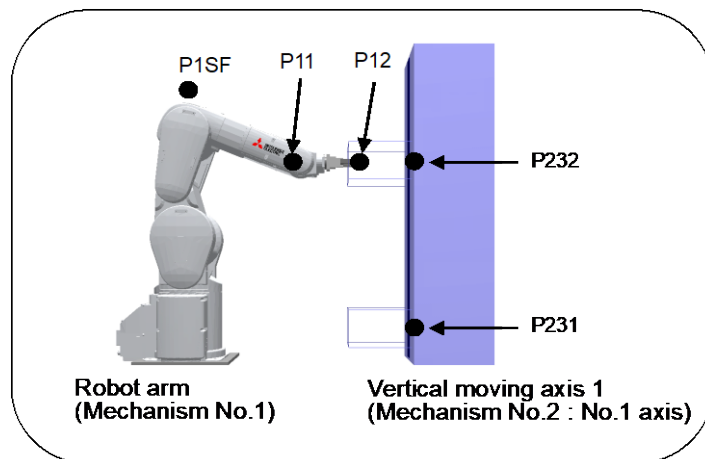

| Mechanism name | Position variable name | Explanation |
|--------------------------------------------------|------------------------|-----------------------------------------------------------------------------------------------------------------------|
| Robot arm (Mechanism No.1) | P1SF | Safe position |
| | P11 | Front of the position where the standard robot unloads the work from the vertical moving axis 1 (mechanism number 2). |
| | P12 | Position where works are unloaded from vartical moving axis 1 (Mechanism No.2) |
| Rotation axis (Mechanism No.2 : No.1 axis) | P231 | Position to which the work is to be transported |
| | P232 | Position from which the standard robot (mechanism number 1) unloads the work |

8. User Mechanism Settings, Operation, and Commands

(5) Program External Variables

Program external variables are used as interlock variables between mechanisms.
The following variables are used.

| Variable name | Variable (0/1) | Explanation |
|---------------|----------------|----------------------------------------------------------------------------|
| M_01 | 0 | Preparation of work on vartical moving axis 1 complete |
| | 1 | Preparation of work on vartical moving axis 1 incomplete |
| M_02 | 0 | Unloading of work by standard robot from vartical moving axis 1 incomplete |
| | 1 | Unloading of work by standard robot from vartical moving axis 1 complete |

The following flow illustrates only the interlock between mechanisms:

Note that programs 1 and 2 in the diagram start simultaneously. (Refer to " Procedure 2: Setting the task slot parameter " in "(6) Procedure up to program execution".)

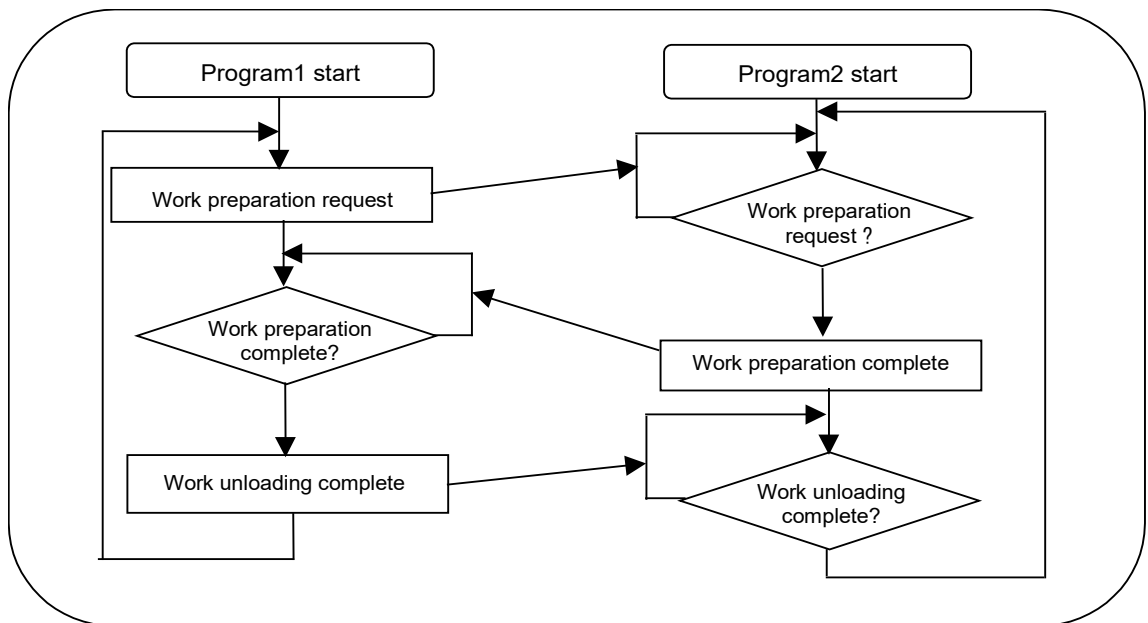

8. User Mechanism Settings, Operation, and Commands

(6) Procedure up to program execution

Procedure 1 : Program creation

<1>Program of mechanism number 1 (Program name:1)

| | |
|------------------------------|----------------------------------------------------------------------------|
| 100 GetM 1 | ' Gets mechanism 1 |
| 110 M_01#=0 | ' Interlock variable is initialized |
| 120 M_02#=0 | ' Interlock variable is initialized |
| 130 Mov P1SF | ' Moves to safe position |
| 140 *LOOP | |
| 150 M_01#=1 | ' Requests for preparation of work on vertical moving axis |
| 160 If M_01#=1 Then GoTo 160 | ' Waits for completion of preparation of work on vertical moving axis |
| 170 Mov P11,-10 | ' Moves 10 mm below P11 |
| 180 Mvs P12,-10 | ' Moves 10 mm below P12 |
| 190 Mvs P12 | ' Move to P12 |
| 200 M_Out(10)=0 | ' Pickup workpiece |
| 210 Dly 0.05 | ' Waits for 0.05 sec of vacuum timer |
| 220 Mvs P12,10 | ' Moves 10 mm above P12 |
| 230 Mvs P11,10 | ' Moves 10 mm above P11 |
| 240 Dly 0.1 | ' Waits for completion (static) of operation (set values must be adjusted) |
| 250 M_02#=1 | ' Unloading of work from vertical moving axis is complete. |
| 260 Mov P1SF | ' Move to safe position |
| 270 GoTo *LOOP | |

<2>Program of mechanism number 2 (Program name:2)

| | |
|---------------------------------|-------------------------------------------------------------------------------|
| 100 GetM 2 | ' Gets mechanism 2 |
| 110 M_Out(11)=0 | ' Prohibits work transport to external location |
| 120 PMV=P_Curr(2) | ' Reads current position |
| 130 PMV.X=P231.X | ' Rewrites element of axis 1 (vertical moving axis 1) of current position |
| 140 Mov PMV | ' Moves to work transport position |
| 150 Dly 0.1 | ' Waits for completion (static) of operation (set values must be adjusted) |
| 160 *LOOP | |
| 170 If M_01#=0 Then GoTo 170 | ' Waits requests for request of preparation of work on vertical moving axis 1 |
| 180 M_Out(11)=1 | ' Permits work transport to external location |
| 190 If M_In(11)=0 Then GoTo 190 | ' Waits for completion of work transport from external location |
| 200 M_Out(11)=0 | ' Prohibits work transport to external location |
| 210 PMV=P_Curr(2) | ' Reads current position |
| 220 PMV.X=P232.X | ' Rewrites element of axis 1 (vertical moving axis 1) of current position |
| 230 Mov PMV | ' Moves to the position where robot unload work |
| 240 Dly 0.1 | ' Waits for completion (static) of operation (set values must be adjusted) |
| 250 M_02#=0 | ' Requests to unload the work from the moving axis. |
| 260 M_01#=0 | ' Preparation of work on vertical moving axis 1 incomplete. |
| 270 If M_02#=0 Then GoTo 270 | ' Waits for completion of unload the work from vertical moving axis |
| 280 PMV=P_Curr(2) | ' Reads current position |
| 290 PMV.X=P231.X | ' Rewrites elements of axis 1 (vertical moving axis 1) of current position |
| 300 Mov PMV | ' Moves to work transport position |
| 310 GoTo *LOOP | |

8. User Mechanism Settings, Operation, and Commands

Procedure 2 : Setting the task slot parameter
Set the slot parameters as follows.

| Parameters | Program name | Operation mode | Operation format | Number of executed lines |
|------------|--------------|----------------|------------------|--------------------------|
| SLT1 | 1 | REP | START | 1 |
| SLT2 | 2 | REP | START | 1 |

The slot parameters have the format shown below.
For details refer to separate "Instruction Manual/ Detailed explanations of functions and operations".

SLT* = 1. Program name, 2. Operation format, 3. Starting conditions, 4. Order of priority

| Item of parameter | Default value | Setting value |
|------------------------|---------------|------------------------------------------------------------------------------------------------------|
| 1. Program name | - | Possible to set a registered program name |
| 2. Operation format | REP | REP : Continuous Operation |
| | | CYC : One cycle operation |
| 3. Starting conditions | START | START : Execution of a program using the START button on the operation panel or the I/O START signal |
| | | ALWAYS : Execution of a program when the controller's power is turned on |
| | | ERROR : Execution of a program when the controller is in error status |
| 4. Order of priority | 1 | 1 to 31: Number of lines executed at one time at multitask operation |

Procedure 3 : Reflecting the task slot parameters

Turn off the power to enable the SLT1 and SLT2 parameters, and then turn on the power again.

Procedure 4 : Starting

Run the program 1 in the OPERATION screen of the teaching pendant. When the program 1 is started, the program 2 starts its operation simultaneously.

9. Such a Case

- (1) An initializing error occurs on the servo amplifier.
 - Check the connection of the cable and connector. (Refer to "this manual/5 Connection and Wiring".)
 - Check the setting of the axis selection switch and robot parameter (AXNUM, AXMENO, AXJNO) of the amplifier. (Refer to "this manual/6 Servo system setting".)
- (2) The moving direction of the additional axis is reversed.
 - Check the setting of the parameter AXSPOL of the robot. (Refer to "this manual/7.1 Description of parameters, 8.2 Description of parameters".)
 - Check the setting of the parameter PA14 POL of the servo amplifier. (Refer to "this manual/6.2 Parameter setting of servo amplifier".)
- (3) The position varies every time when the power supply is turned ON and OFF.
 - Check the setting of the parameter PA03 ABS of the servo amplifier. (Refer to "this manual/6.2 Parameter setting of servo amplifier".)
 - Check the setting of the parameter PA14 POL of the servo amplifier. (Refer to "this manual/6.2 Parameter setting of servo amplifier".)
- (4) The additional axis does not move smoothly or satisfactorily.
 - Adjust the parameter of the servo amplifier. For details, refer to "Instruction Manual for Servo Amplifier".

10. Appendix

10.1 Error list

When an error occurs, the error LED in the front of the controller will light or flash.

Also the error No, and message will appear on the T/B LCD display.

The error numbers, messages, cause and measures to be taken related to the additional axis function are displayed in the following table.

For the errors not listed here, refer to separate "Instruction Manual/ Troubleshooting".

Also, a detailed message will be displayed on the Error History screen of the T/B, depending on the error No. of the error occurred. Check by displaying the Error History screen after resetting the error.

If the error recurs even after the measures in the table are taken, contact your dealer.

[Note] The meaning of the error number in the following table are shown below.

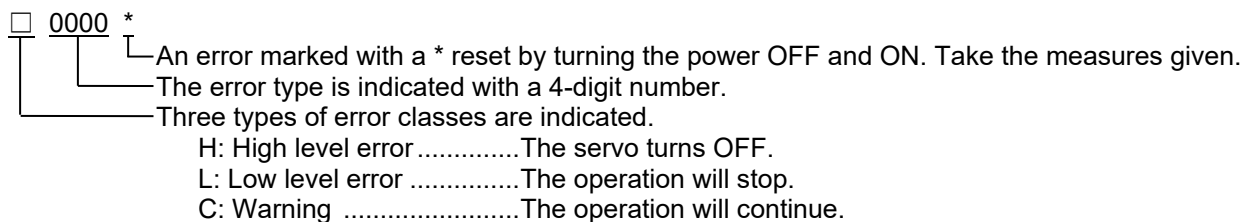

| Error No. | Error cause and measures | |
|-----------|--------------------------|---------------------------------------------------------------------------------------------------------------------------|
| H7600* | Error message) | Mechanism number of additional axis is illegal. |
| | Cause) | The value of AXMENO (mechanism No. used) parameter is illegal. |
| | Countermeasure) | On the mechanical additional axis, change "0" to a value which is smaller than set to AXUNUM (number of mechanisms used). |
| H7601* | Error message) | Axis number of additional axis is illegal. |
| | Cause) | The value of AXJNO (setting axis No.) is illegal. |
| | Countermeasure) | Change the value of this parameter from 1 to 3. Change the value of this parameter to a order from 1. |
| H7602* | Error message) | Axis numbers of additional axis are overlap. |
| | Cause) | As the parameter value of AXJNO (setting axis No.), the same value is set at two or more elements. |
| | Countermeasure) | Change the values of the element Nos. which set the same values at this parameter AXMENO, to all different values. |
| H7603* | Error message) | Unit of additional axis is illegal. |
| | Cause) | The value of AXUNT (unit axis) parameter is illegal. |
| | Countermeasure) | Change the values of all elements of this parameter to "0" or "1". |
| H7604* | Error message) | Acceleration time of additional axis is illegal. |
| | Cause) | The value of AXACC (acceleration time) parameter is illegal. |
| | Countermeasure) | Change the values of all elements of this parameter to positive real numbers. |
| H7605* | Error message) | Deceleration time of additional axis is illegal. |
| | Cause) | The value of AXDEC (deceleration time) parameter is illegal. |
| | Countermeasure) | Change the values of all elements of this parameter to positive real numbers. |
| H7606* | Error message) | Gear ratio numerator of additional axis is illegal. |
| | Cause) | The value of AXGRTN (total speed ratio numerator) parameter is illegal. |
| | Countermeasure) | Change the values of all elements of this parameter to positive integers. |
| H7607* | Error message) | Gear ratio denominator of additional axis is illegal. |
| | Cause) | The value of AXGRTD (total speed ratio denominator) parameter is illegal. |
| | Countermeasure) | Change the values of all elements of this parameter to positive integers. |

| Error No. | Error cause and measures | |
|-----------|--------------------------|-----------------------------------------------------------------------------------|
| H7609* | Error message) | Motor rated speed of additional axis is illegal. |
| | Cause) | The value of AXMREV (rated speed) parameter is illegal. |
| | Countermeasure) | Change the values of all elements of this parameter to positive integers. |
| H7610* | Error message) | Motor maximum speed of additional axis is illegal. |
| | Cause) | The value of AXJMX (maximum speed) parameter is illegal. |
| | Countermeasure) | Change the values of all elements of this parameter to positive integers. |
| H7611* | Error message) | Encoder pulse of additional axis is illegal. |
| | Cause) | The value of AXENCR (encoder resolution) parameter is illegal. |
| | Countermeasure) | Change the values of all elements of this parameter to positive integers. |
| H7612* | Error message) | JOG smoothening time constant of additional axis is illegal. |
| | Cause) | The value of AXJOGTS (JOG smoothening time constant) parameter is illegal. |
| | Countermeasure) | Change the values of all elements of this parameter to 0 or positive real number. |
| H7613* | Error message) | Turn OFF the power supply once, and turn ON it again. |
| | Cause) | It is necessary to turn OFF the power supply once. |
| | Countermeasure) | Turn OFF the power supply of the controller, and turn it ON again. |

10.2 Add axis limit switch function

10.2.1 Outline

Add axis limit switch function watches the state of the limit switch connected to the servo amplifier (MR-J4-□B), and when the switch was input, this function stops the robot by the error.

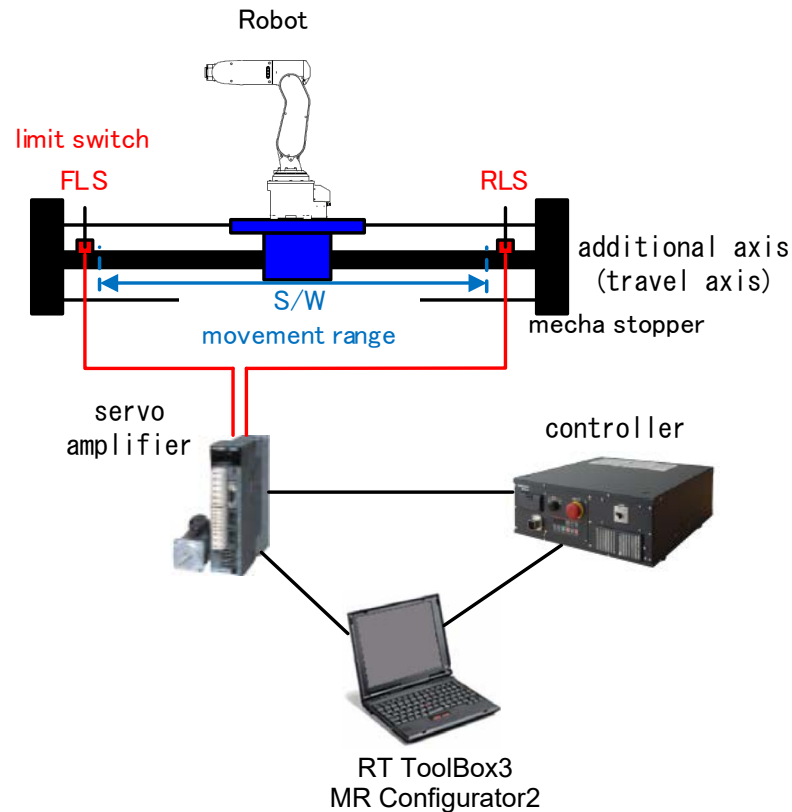

Fig. 11.2.1 Example of equipment constitution

Like the figure above, when the additional axis was installed as the robot travel axis and the limit switch (FLS/RLS) installed on the travel axis was input, the function which brings about an error, does servo off and suspends movement of the robot.

This figure is an example of the robot additional axis. When using the additional axis as the user mechanism, this function can be used.

When it's restored from the state that FLS/RLS was input, release the brake and move the arm by hand. Or, referring to "Operation to Temporarily Reset an Error that Cannot Be Canceled" in the separate volume "Instruction Manual/Detailed Explanation of Functions and Operations", reset the error and move the axis "n" within the operation range using JOG operation.

10.2.2 Setting

(1) FLS/RLS connection setting

When using this function, the limit switch (FLS/RLS) is connected to the servo amplifier (MR-J4-B). How to connect the FLS / RLS and servo amplifier, please refer to the instruction manual of the MR-J4-□B (SH-030101) "3. SIGNALS AND WIRING".

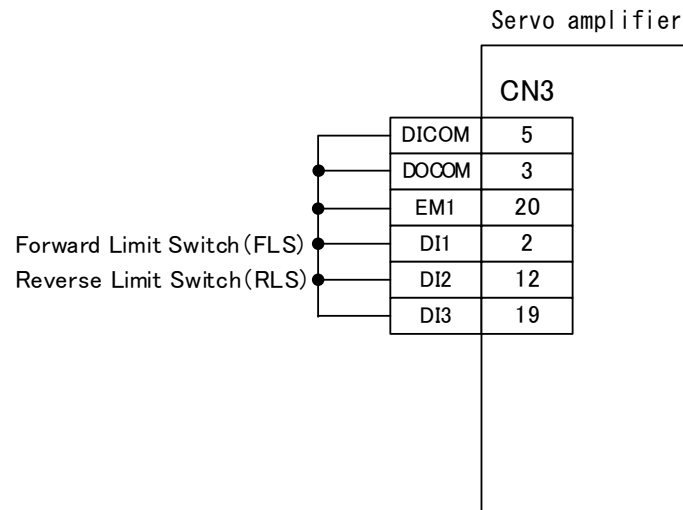

Fig. 11.2.2 FLS/RLS signal connection

Please change the parameters of the servo amplifier like the following table by refer to "6.2 Parameter setting of servo amplifier".

Table 11.2.1 Parameter configuration of the servo amplifier

| No. | Name | Initial value | Change value |
|------|--------------------------|---------------|--------------|
| PD03 | For manufacturer setting | 0000h | 0020h |
| PD04 | For manufacturer setting | 0000h | 0021h |

10Appendix

(2) Parameter

When using this function, set the following parameter.

Table 11.2.2 Parameter configuration of robot controller

| Parameter name | Description | Type Number of arrays | Details explanation | Factory setting |
|----------------|--------------------------------------------------------------------|--------------------------|-------------------------------------------------------------------------------------------------------------------------------------------------------------------------------------------------------------------------------------------------------------------------------------------------------------------------------------------------------------------------------------------------------------------------------------------------------------------------------------------------------------------------------------------|-------------------------------------|
| AXLSIN | Enable / Disable of the Add axis limit switch function. | integer 16 | Define the enable or disable of the Add axis limit switch function for each additional axis. (Enable / Disable = 1 / 0) When additional axis doesn't exist, this setting becomes invalid. 1st element : additional axis No.1 2nd element : additional axis No.2 3rd element : additional axis No.3 4th element : addition axis No.4 5th element : addition axis No.5 6th element : addition axis No.6 7th element : addition axis No.7 8th element : addition axis No.8 9th to 16th element : Not Used | 0,0,0,0,0,0,0,0, 0,0,0,0,0,0,0,0 |
| AXLSINB | Normal Open or Normal Close designation of the limit switch input. | integer 1 | Change the limit switch input between the normal open and normal close. This setting is common in FLS/RLS of all servo amplifiers. (Normal open/Normal close = 0/1) | 0 (normal open) |

When the state of FLS/RLS signal is output as Dedicated input/output, set the following parameter.

Table 11.2.3 Parameter configuration of robot controller

| Parameter name | Description | No. of arrays | Details explanation | Factory setting |
|----------------|------------------------------------|---------------|-----------------------------------------------------------------------------------------------------------------------------------------------------------------------------------------------------------------------------------------------------------------------------------------------------------------------------------------------------------------------------------------------------------------------------------------------------------------------------------------------------------------------------------------------------------------------------------------------------|-----------------|
| AXFLSST | Output signal number of FLS state. | integer 2 | Specify the dedicated output signal number to output the state of the FLS signal. (start No. , end No.) [Setting example] AXFLSST = 16, 16 : The output of the state of the only No.1 add axis. AXFLSST = 16, 17 : The output of the state of the No.1 and 2 add axis. AXFLSST = 16, 23 : The output of the state of the all add axis. Incorrect settings example) AXFLSST = -1, -1 : Setting invalid(No outputs) AXFLSST = -1, 16 : to Setting invalid(No Error) AXFLSST = 16, -1 : to Setting invalid(No Error) AXFLSST = 17, 16 : to Setting invalid(Error L7081) | -1,-1 |
| AXRLSST | Output signal number of RLS state. | integer 2 | Specify the dedicated output signal number to output the state of the RLS signal. (start No. , end No.) [Setting example] Refer to AXFLSST for setting example. | -1,-1 |

[Setting example]

When using this function on the servo amplifier set "Control axis No. of servo" as the 1st axis, and the limit switch is closed, set the following parameter.

Table 11.2.4 Example of parameter configuration

| Parameter name | Meaning of the value | Value |
|----------------|---------------------------------------------------------------|------------------------------------------------------------------|
| AXLSIN | Add axis limit switch function Enable(1)/Disable (0) | 1,0,0,0,0,0,0,0,0,0,0,0,0,0,0,0 (Set "1" to the 1st element.) |
| AXLSINB | Add axis limit switch input signal normally close(1) /open(0) | 1 (normal close) |

When the state of the FLS signal is output in output signal number 10 and the state of the RLS signal is output in output signal number 11, set the following parameter.

Table 11.2.5 Example of parameter configuration

| Parameter name | Meaning of the value | Value |
|----------------|--------------------------------------------------|-------|
| AXFLSST | State of Add axis FLS signal (start, end) OUTPUT | 10,10 |
| AXRLSST | State of Add axis RLS signal (start, end) OUTPUT | 11,11 |

10.2.3 Error list

Table 11.2.6 Error list

| Error No. | Error cause and measures | |
|-------------------------------------------------|--------------------------|--------------------------------------------------------------------------------------------------------------------------------------------------------------------------------------------------------------------------------------------------------------------------------------------------------------------|
| H264n (n indicates the axis number (1 to 8)) | Error message | Add axis FLS signal is input |
| | Cause | Add axis FLS signal is input |
| | Measures | Release the brake and move the arm by hand. Or, referring to "Operation to Temporarily Reset an Error that Cannot Be Canceled" in the separate volume "Instruction Manual/Detailed Explanation of Functions and Operations", reset the error and move the axis "n" within the operation range using JOG operation. |
| H265n (n indicates the axis number (1 to 8)) | Error message | Add axis RLS signal is input |
| | Cause | Add axis RLS signal is input |
| | Measures | Release the brake and move the arm by hand. Or, referring to "Operation to Temporarily Reset an Error that Cannot Be Canceled" in the separate volume "Instruction Manual/Detailed Explanation of Functions and Operations", reset the error and move the axis "n" within the operation range using JOG operation. |

mitsubishi electric corporation

HEAD OFFICE: TOKYO BLDG., 2-7-3, MARUNOUCHI, CHIYODA-KU, TOKYO 100-8310, JAPAN
NAGOYA WORKS: 1-14, YADA-MINAMI 5-CHOME, HIGASHI-KU, NAGOYA 461-8670, JAPAN