



ZEF005541602

MELSEC iQ-R PLC Module Converter VS-R262BH-M2R User's Manual

Applicable sensor

MRE-32SP061

MRE-G[]SP061

MRE-32SP074

MRE-G[]SP074

MRE-32SP097

MRE-G[]SP097

MRE-32SP101

MRE-G []SP101



CONTENTS

SAFETY PRECAUTIONS.....	i
INTRODUCTION.....	iv
RELEVANT MANUALS.....	iv
TRADEMARKS.....	iv
REVISION HISTORY.....	v
1. OVERVIEW.....	1
1.1 Features.....	3
1.2 Definitions.....	4
2. SYSTEM CONFIGURATION.....	5
2.1 Overall Configuration.....	5
2.2 Applicable System.....	6
3. VS-R262BH SPECIFICATIONS.....	7
3.1 General Specifications.....	7
3.2 Performance Specifications.....	8
3.3 Function List.....	8
3.4 Input/Output Signals between VS-R262BH and PLC CPU.....	9
3.4.1 Input/output signal details.....	10
3.5 Buffer Memory.....	12
3.5.1 Sensor value storage area (Address 0, 1 [1000, 1001]).....	13
3.5.2 Current position value storage area (Address 2 to 5 [1002 to 1005]).....	13
3.5.3 Input status storage area (Address 6 [1006]).....	13
3.5.4 Error code storage area (Address 7 [1007]).....	14
3.5.5 Current position setting value storage area (Address 690, 691 [1690, 1691]).....	14
3.5.6 Current position setting "disabled" area (Address 694 [1694]).....	14
3.5.7 Axis enabled/disabled setting area (Address 702 [1702]).....	15
3.5.8 Inter-module synchronization state storage area (Address 800 [1800]).....	15
3.5.9 Synchronization sensor value storage area (Address 802, 803 [1802, 1803]).....	15
3.5.10 Synchronization current position value storage area (Address 804 to 807 [1804 to 1807]).....	15
4. HANDLING and WIRING.....	17
4.1 VS-R262BH Handling Precautions.....	17
4.2 Wiring Precautions for ABSOCODER Cables.....	17
4.3 ABSOCODER Sensor Installation Precautions.....	18
4.3.1 Installation of ABSOCODER sensor.....	18
4.3.2 Precautions for connecting ABSOCODER sensors.....	20
4.4 Name of Parts.....	21
5. CURRENT POSITION DETECTION FUNCTION.....	23
5.1 Function Description.....	23
5.1.1 Current position detection function.....	23
5.1.2 Current position setting function.....	24
5.2 Pre-Operation Setting Sequence.....	25
5.3 Parameter Settings.....	26
5.3.1 Basic settings.....	26
5.3.2 Refresh setting.....	27
5.3.3 Valid/Invalid of Parameters.....	28
5.4 Programming.....	29
5.4.1 Program creation precautions.....	29
5.4.2 Program for current position monitor display.....	30
5.4.3 Program for error code readout and error reset.....	31
5.4.4 Program for current position setting.....	33



6. INTER-MODULE SYNCHRONIZATION FUNCTION	35
6.1 Operation	35
6.2 Settings	36
6.3 Readout of the synchronous value	36
7. ONLINE MODULE CHANGE FUNCTION.....	37
7.1 Settings	37
7.2 REPLACEMENT PROCEDURE	38
7.2.1 Changing a module by controlling special relays and special registers	38
7.2.2 Changing a module directly	38
8. TROUBLESHOOTING.....	39
8.1 Error Code List	39
8.2 Troubleshooting Flowchart	40
8.3 Flowchart when Current Position Setting is Impossible	41
8.4 Flowchart when the Current Position Value doesn't Change	42
APPENDIX 1 CE MARKING.....	43
APPENDIX 1.1 EMC Directives.....	43
APPENDIX 1.2 EMC Directive and Standards	43
APPENDIX 1.3 Low Voltage Directive.....	43
APPENDIX 1.4 Measures for EMC Compliance and Restriction	43
APPENDIX 2 ABSOCODER SENSOR SPECIFICATIONS	44
Appendix 2.1 ABSOCODER Sensor for VS-R262BH-M2R	44
Appendix 2.1.1 Specifications.....	44
Appendix 2.1.2 ABSOCODER Sensor Dimensions	47
Appendix 2.2 ABSOCODER Cable	50
Appendix 2.2.1 Specifications.....	50
Appendix 2.2.2 Cable length restrictions	50
Appendix 2.2.3 ABSOCODER Cable Dimensions.....	51
Appendix 2.2.4 ABSOCODER Cable Connection	52
APPENDIX 3 DIMENSIONS.....	55
Appendix 3.1 VS-R262BH Position Detection Module.....	55
APPENDIX 4 ABSOCODER SENSOR CHECK LIST.....	57
APPENDIX 5 I/O SIGNALS and BUFFER MEMORY FUNCTION LIST for VS-R262BH.....	59
APPENDIX 6 EVENT CODE LISTS for VS-R262BH.....	60

SAFETY PRECAUTIONS

(Read these precautions before using this product.)

Before using this product, please read this manual and the relevant manuals carefully and pay full attention to safety to handle the product correctly.

The precautions given in this manual are concerned with this product only. For the safety precautions of the programmable controller system, refer to the MELSEC iQ-R Module Configuration Manual.

In this manual, the safety precautions are classified into two levels: "  WARNING" and "  CAUTION".

WARNING

Procedures which may lead to a dangerous condition and cause death or serious injury if not carried out properly.

CAUTION

Procedures which may lead to a dangerous condition and cause superficial to medium injury, or physical damage only, if not carried out properly.

Under some circumstances, failure to observe the precautions given under "  CAUTION" may lead to serious consequences.

Observe the precautions of both levels because they are important for personal and system safety.

Make sure that the end users read this manual and then keep the manual in a safe place for future reference.

【Application Limitation】

This product is not designed to be used under any situation affecting human life. When you are considering using this product for special purposes such as medical equipment, aerospace equipment, nuclear power control systems, traffic systems, and etc., please consult with NSD.

This product is designed to be used under the industrial environments categorized in Class A device. The supplier and user may be required to take appropriate measures.

【Design Precautions】

WARNING

- Provide an external safety circuit so that the entire system functions safely even when the external power supply or the CPU module is faulty.

Failure to do so may lead to incorrect output or malfunction, resulting in an accident.

- (1) Provide an external circuit of PLC emergency stop circuit and an interlock circuit to prevent the machine from being damaged (e.g. position detection upper and lower limits).
- (2) When this module detects an error, all output signals may turn OFF depending on the type of the error. Provide an external fail safe circuit.
- (3) Outputs may remain on or off due to a failure of a transistor for external output. Configure an external circuit for monitoring output signals that could cause a serious accident.

CAUTION

- Do not bind or close the control cable and the communication cable with the main circuit cable and the power cable. Keep the former cables at least 300 mm or more away from the latter cables.

Failure to do so may result in malfunction due to noise.

【Installation Precautions】



WARNING

- Be sure to shut off all power before mounting/removing this module.
Failure to do this could result in equipment damage.



CAUTION

- Use the programmable controller in an environment that meets the general specifications in the Safety Guidelines included with the base unit. Failure to do so may result in electric shock, fire, malfunction, or damage to or deterioration of the product.
- To mount a module, place the concave part(s) located at the bottom onto the guide(s) of the base unit, and push in the module until the hook(s) located at the top snaps into place. Incorrect interconnection may cause malfunction, failure, or drop of the module.
For use in vibratory environment, tighten the module with screws.
Tighten the screws within the specified torque range.
Loose screws can cause drops of the screws, short circuit or malfunction.
Over-tightening screws may damage the screws and/or the module, This can cause drops, short circuit or malfunction.
- Never directly touch this module's conductive areas or electrical components, because this can cause this module to malfunction or failure.
- Firmly connect the sensor connector to this module's connector.
Failure to do so may result in poor contact, leading to incorrect input and output.

【Wiring Precautions】



WARNING

- Shut off the external power supply (all phases) used in the system before installation and wiring.
Failure to do so may result in electric shock or cause the module to fail or malfunction.



CAUTION

- Prevent foreign matter such as dust or wire chips from entering the module. Such foreign matter can cause a fire, failure, or malfunction.
- A protective film is attached to the top of the module to prevent foreign matter, such as wire chips, from entering the module during wiring. Do not remove the film during wiring. Remove it for heat dissipation before system operation.

【Start-up and Maintenance Precautions】

WARNING

- Be sure to shut off all power before cleaning this module or tightening screws.
Failure to do so may result in failure or malfunction of this module.
Loose screws can cause drops of the screws, short circuit or malfunction.
Over-tightening screws may damage the screws and/or the module, This can cause drops, short circuit or malfunction.

CAUTION

- Do not disassemble, or modify this module.
Failure to do so may result in failure, malfunction, injury, or fire.
- Be sure to shut off all power before mounting/removing this module.
Failure to do this could result in failure or malfunction of this module.
- Do not mount/remove the module to/from the base unit more than 50 times after the first use of the product. (IEC 61131-2 compliant)
Failure to do so may cause malfunction.
- Before starting test operation, set the parameter speed limit value to the slowest value, and make sure that operation can be stopped immediately if a hazardous state occurs.
- Always make sure to touch a grounded metal to discharge the static electricity from your body, etc., before touching the module.
Failure to do so may cause a failure or malfunctions of this module.

【Disposal Precautions】

CAUTION

- Be sure to handle this module as industrial waste when disposing of it.

INTRODUCTION

Thank you for purchasing the VS-R262BH module.

Always read through this manual, and fully comprehend the functions and performance of VS-R262BH before starting use to ensure correct usage of this product.

Please submit this manual to the end user.

RELEVANT MANUALS

VS-R262BH is a module for MELSEC iQ-R.

Read the following Mitsubishi Electric Corporations' manuals in addition to this manual.

- MELSEC iQ-R Module Configuration Manual (SH-081262)
- MELSEC iQ-R Inter-Module Synchronization Function Reference Manual (SH-081401)
- MELSEC iQ-R Online Module Change Manual (SH-081501)
- GX Works3 Operating Manual (SH-081215)

TRADEMARKS

MELSEC is the trademark or registered trademark of Mitsubishi Electric Corporation.

Other companies' and products' names are the trademark or registered trademark of each company.

REVISION HISTORY

The document No. appears at the upper right of this manual's cover page.

Document No.	Date	Revision Description
ZEF005541600	8, Aug., 2018	1st Edition Japanese document: ZEF005541101
ZEF005541601	31, May, 2019	2nd Edition Japanese document: ZEF005541102
ZEF005541602	15, Dec., 2022	3rd Edition Japanese document: ZEF005541102

1. OVERVIEW

1. OVERVIEW

This user's manual contains the specifications, and operation/programming procedures for VS-R262BH-M2R (*1) which is to be used in combination with a Mitsubishi Electric Corporation. MELSEC iQ-R Series programmable controller.

VS-R262BH combines a rotary position sensor to detect the position of the machine being controlled.

VS-R262BH is used with the ABSOCODER sensor (turn type).

The ABSOCODER sensor is a magnetic position sensor which can replace incremental type encoders which have been widely used until now. Machine positions are detected easily and flexibly by combining VS-R262BH and ABSOCODER sensor. VS-R262BH can be used to automatically control the position detection of the conveyor, press machine, assembly machine, packing machine, etc.

In addition to main functions (current position detection), VS-R262BH offers a wealth of auxiliary functions.

NOTE *1: VS-R262BH-M2R is shown as VS-R262BH on this manual.

*2: Input/output devices of an axis-2 side and buffer memory addresses are shown in [].

Current Position Detection Function

VS-R262BH's current position detection function detects the current position using an ABSOCODER sensor. Conventionally, this was detected using an incremental format encoder in conjunction with a counter unit.

The above conventional method has several disadvantages; origin-point return is necessary when power supply is interrupted due to power failure, etc.

VS-R262BH's current position detection function has eliminated these problems by offering a flexible setting format which provides maintenance-free operation.

(1) Operation Example of System with Incremental Format Encoder and Counter

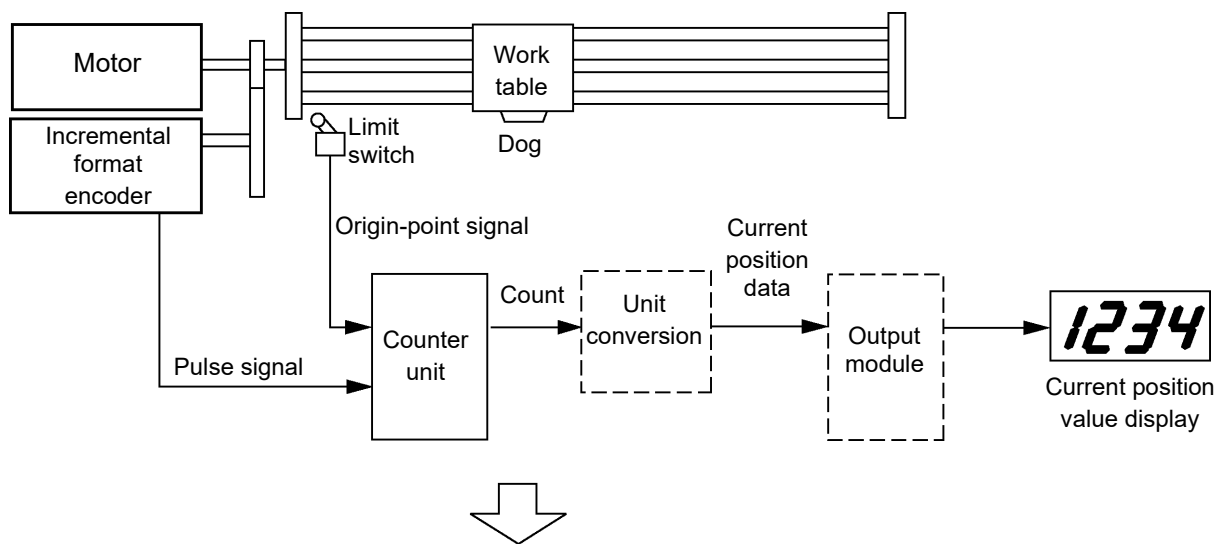

(2) Operation Example of System with VS-R262BH

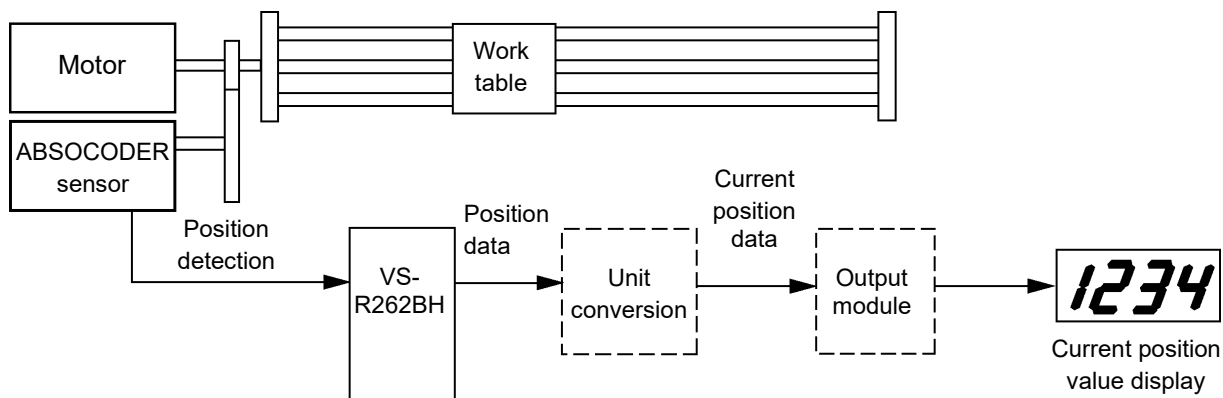
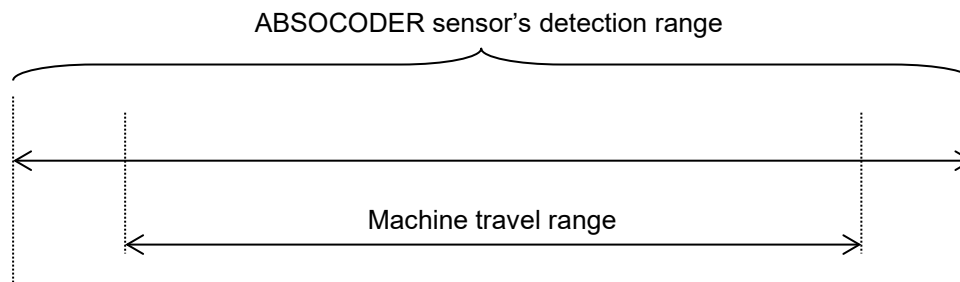

Fig. 1.1 Example of Current Position Detection Function

IMPORTANT

Select an ABSOCODER sensor that can provide an absolute position detection range covering the machine travel range (Refer to Appendix 2 for details regarding the ABSOCODER sensor.)



1.1 Features

VS-R262BH has the following features:

(1) High reliability

An absolute position detection format ensures accurate position detection even if a power interruption or unexpected noise condition occurs. An origin returning operation is not required.

(2) High resolution

The 32-turn turn-type ABSOCODER sensor (the MRE Series) offers a resolution factor of 4096 divisions per 1 turn of the sensor shaft.

The resolution factor for a 64-turn turn-type ABSOCODER sensor is half the amount given above. Refer to Appendix 2 for details regarding the relationship between the number of turns and the resolution.

(3) High-speed response

VS-R262BH is not affected by the PLC's scan time.

The position detection is executed every 0.1ms*.

*: This sampling time is supported by version seal C or later.

(4) Current position setting function:

If a positional discrepancy occurs between the machine's position and the ABSOCODER sensor's position, the current position can be set to the desired value by the output signal from the PLC CPU.

(5) Inter-module synchronization function

VS-R262BH can detect the position with matching the timing when each module of the MELSEC iQ-R series inputs/outputs the signal.

(6) Online module change function

The module can be changed to a new one without stopping the system during the energization (online).

(7) Compliance with CE standards

VS-R262BH complies with CE (EMC Directive) standards.

1.2 Definitions

(1) ABSOCODER

ABSOCODER is the generic name given to the NSD-developed position sensor which detects rotational/linear displacement, speed, and acceleration, using an absolute position detection method with a digital (or analog) output.

ABSOCODER consists of two main components:

The sensor, where displacement is detected by the change in magnetic resistance, and **the converter**, where the sensor's output signal (when an AC excitation signal has been applied to the sensor) is converted into absolute data.

The converter for a turn-type ABSOCODER sensor is built-in to VS-R262BH.

(2) Sensor shaft rotation direction

Current Position Value in CW Direction:

Position data value will increase when the sensor shaft rotates in the CW direction in the figure below.

Current Position Value in CCW Direction:

Position data value will increase when the sensor shaft rotates in the CCW direction in the figure below.

There are two data areas that may be used to obtain a position data from VS-R262BH. For details about the two areas, refer to Section 3.5.2.

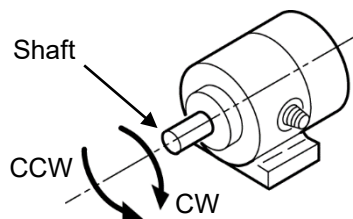

(3) Current position value

This value indicates where the machine is currently positioned within the machine detection range. This can be expressed in binary code.

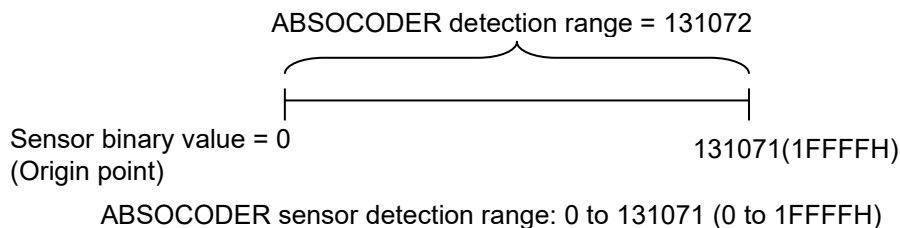

2. SYSTEM CONFIGURATION

2. SYSTEM CONFIGURATION

2.1 Overall Configuration

The overall configuration of the Mitsubishi Electric Corporation. MELSEC iQ-R Series using VS-R262BH is shown below.

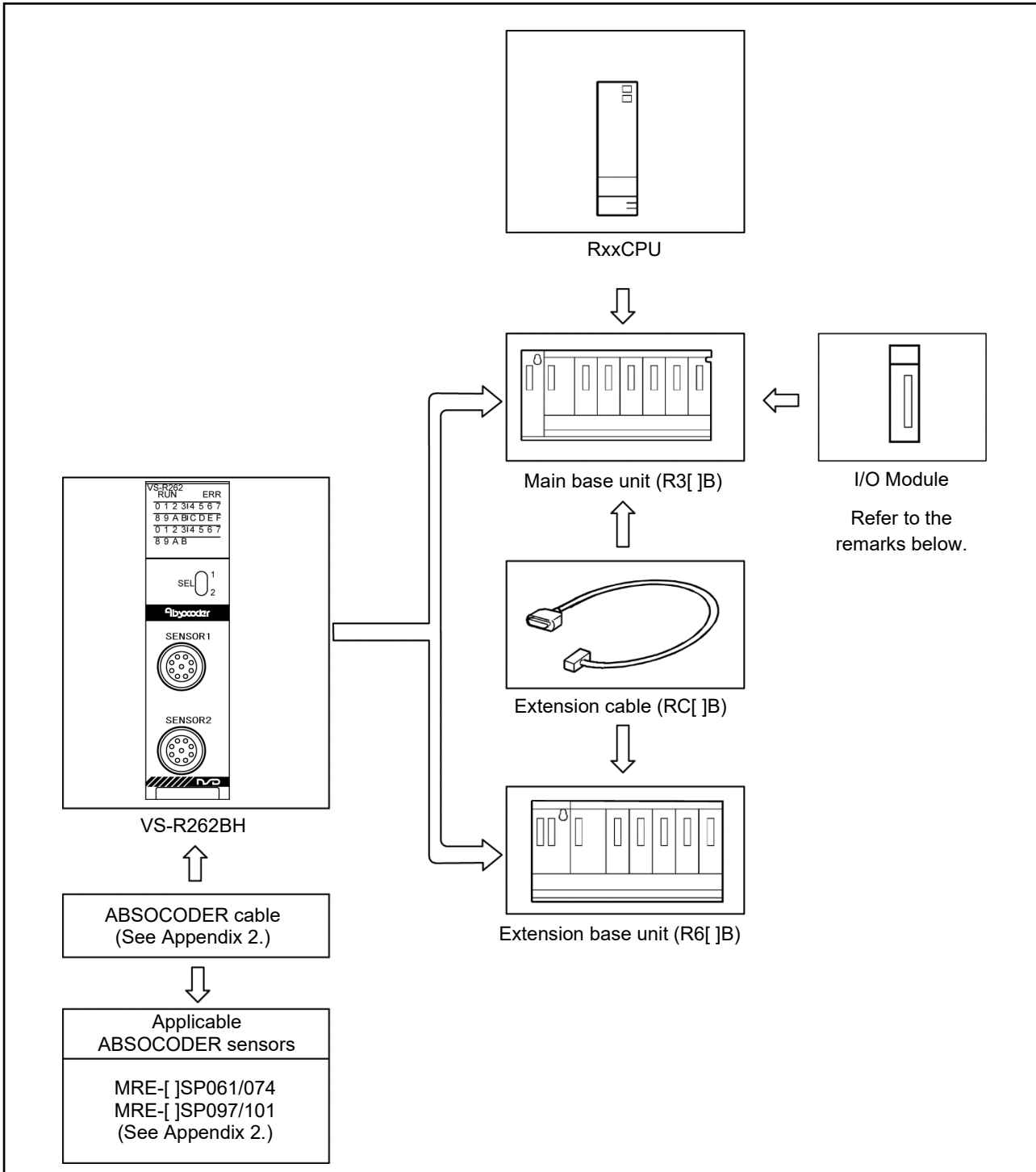

Fig. 2.1 VS-R262BH System Configuration

REMARKS

As VS-R262BH does not have an external input/output circuit, input and output have to be executed using a sequence program. Select and prepare an input/output module according to the required functions.

2.2 Applicable System

VS-R262BH can be used in the following system.

(1) Applicable CPU module

Refer to NSD web site for CPU module models with which VS-R262BH can be used.

(2) Number of mountable modules

Pay attention to the power supply capacity before mounting modules.

Change the combination of the modules if the power supply capacity is insufficient.

(3) Applicable base units

VS-R262BH can be installed to any I/O slot of a base unit.

REMARKS

As VS-R262BH does not have an external input/output circuit, input and output have to be executed using a sequence program.

3. VS-R262BH SPECIFICATIONS

3. VS-R262BH SPECIFICATIONS

Shown below are the VS-R262BH specifications.

For the ABSOCODER sensor specifications, refer to Appendix 2, "ABSOCODER SENSOR SPECIFICATIONS".

3.1 General Specifications

Table 3.1 General Specifications

Items	Specifications					
Operating ambient temperature	0 to 55°C					
Storage ambient temperature	-25 to 75°C					
Operating ambient humidity	5 to 95%RH, non-condensing					
Storage ambient humidity	5~95%RH, non-condensing					
Vibration resistance	Compliant with JIS B 3502 and IEC 61131-2	—	Frequency	Constant acceleration	Half amplitude	Sweep count
		Under intermittent vibration	5 to 8.4Hz	—	3.5mm	10 times each in X, Y, and Z directions
			8.4 to 150Hz	9.8m/s ²	—	
		Under continuous vibration	5 to 8.4Hz	—	1.75mm	—
8.4 to 150Hz	4.9m/s ²		—	—		
Shock resistance	Compliant with JIS B 3502 and IEC 61131-2 (147m/s ² , 3 times each in X, Y, and Z bidirections)					
Operating atmosphere	No corrosive gases, flammable gases, less conductive dust					
Operating altitude *1	0 to 2000m					
Installation location	Inside a control panel					
Overvoltage category *2	II or less					
Pollution degree *3	2 or less					
Equipment class	Class I					

REMARKS

*1: Do not use or store VS-R262BH under pressure higher than the atmospheric pressure of altitude 0m. Doing so may cause malfunction.

*2: This indicates the section of the power supply to which the equipment is assumed to be connected between the public electrical power distribution network and the machinery within premises. Category II applies to equipment for which electrical power is supplied from fixed facilities. The surge voltage withstand level for up to the rated voltage of 300V is 2500V.

*3: This index indicates the degree to which conductive material is generated in terms of the environment in which the equipment is used. Pollution degree 2 is when only non-conductive pollution occurs. A temporary conductivity caused by condensing must be expected occasionally.

3.2 Performance Specifications

Table 3.2 Performance Specifications

Items	Specifications	Remarks
Number of position detection axes	2	
Position detection method	Absolute format	
Number of divisions	[4096 divisions x 32 turns] to [42.6 divisions x 3072 turns]	Refer to Appendix 2 for details.
Function	- Current position detection function - Current position setting function	
Sampling time [ms]	0.1	Version seal is *C or later
No. of occupied I/O points	32	I/O assignment: 32 points for intelligent function module
Internal current consumption (5VDC) [A]	0.7	
Outline dimensions [mm]	106(h) × 27.8(w) × 107.1(d)	
Mass [kg]	0.2	
Applicable standard	CE Marking (EMC directive)	

3.3 Function List

As shown in table 3.3, VS-R262BH's functions are divided into 2 groups consisting of 'main functions' and 'auxiliary functions'. The main functions of VS-R262BH are useful for actual system control, and the auxiliary functions are to support the main function operations.

Table 3.3 Function List

Function		Description	Reference
Main functions	Current position detection function	The machine position is detected by the ABSOCODER sensor.	Section 5.1.1
Auxiliary functions	Current position setting function	VS-R262BH's current position value is set according to the current and actual machine position of the system.	Section 5.1.2
	Inter-module synchronization function	The VS-R262BH can detect the position with matching the timing when each module of the MELSEC iQ-R series inputs/outputs the signal.	Chapter 6
	Online module change function	The module can be changed to a new one without stopping the system during the energization (online).	Chapter 7

3.4 Input/Output Signals between VS-R262BH and PLC CPU

The input and output signals to the PLC CPU are shown below.

- (1) In the table below, the input/output signals are classified as follows:
 (a) Device X: Input signals from VS-R262BH to PLC CPU.
 (b) Device Y: Output signals from PLC CPU to VS-R262BH.

(2) Input/output signal configuration when VS-R262BH is installed at the base unit's Slot 0.

Signal direction : VS-R262BH → PLC CPU		Signal direction : PLC CPU → VS-R262BH		
Device No.	Signal Name	Device No.	Signal Name	
X 0	Unit ready (VS-R262BH detection)	Y 0	Use prohibited	
X 1	VS-R262BH operation status (online/offline)	Y 1		
X 2	Response for checking unit normality *1	Y 2		
X 3	Use prohibited	Y 3		
X 4	Axis-1 sensor error detection	Y 4		
X 5	Axis-1 error detection	Y 5		
X 6	Use prohibited	Y 6		
X 7		Y 7		
X 8	Axis-2 sensor error detection	Y 8		
X 9	Axis-2 error detection	Y 9		
X A	Use prohibited	Y A		
X B		Y B		
X C		Y C		
X D		Y D		
X E		Y E		
X F		Y F		
X 10			Y 10	PLC ready
X 11			Y 11	Use prohibited
X 12			Y 12	Request for checking unit normality *1
X 13			Y 13	Axis-1 current position setting command (Detected at leading edge)
X 14			Y 14	Use prohibited
X 15			Y 15	
X 16			Y 16	Axis-2 current position setting command (Detected at leading edge)
X 17			Y 17	Use prohibited
X 18			Y 18	
X 19			Y 19	
X 1A		Y 1A		
X 1B		Y 1B		
X 1C		Y 1C	Error reset (Detected at leading edge)	
X 1D		Y 1D	Use prohibited	
X 1E		Y 1E		
X 1F		Y 1F		

*1: These signals are added with version seal ***C** or later.

⚠ NOTES

VS-R262BH's operation cannot be guaranteed if the use prohibition device "Y" is turned ON/OFF by the sequence program.

3.4.1 Input/output signal details

The ON/OFF timing and other conditions for signal input/output between VS-R262BH and PLC CPU are explained below.

(1) Unit ready (X0)

This signal comes OFF when a watchdog timer error is detected by VS-R262BH's self-diagnosis function.

When 'X0' comes OFF, this indicates a VS-R262BH hardware error.

(2) VS-R262BH operation status (online/offline) (X1)

If the 'PLC ready' signal (Y10) is turned ON by the sequence program, VS-R262BH will be set to an 'online' status, and 'X1' will turn ON.

'X1' will go OFF when 'Y10' is turned OFF.

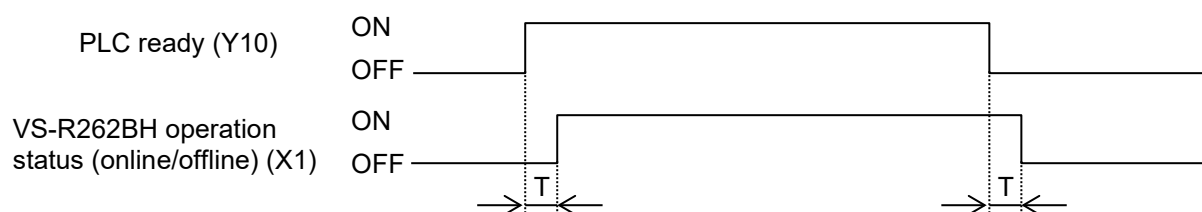

T: response time

- Direct mode : T < 0.4ms
- Refresh mode : T is depended on the refresh timing.
- Via the network : T is depended on the transmission delay.

(3) Response for checking unit normality (X2)

* These signals are added with version seal ***C** or later.

In the case of VS-R262BH is operating normally, 'Request for checking unit normality'(Y12) is turned ON by the sequence program, and 'X2' will turn ON.

'X2' will go OFF when 'Y12' is turned OFF.

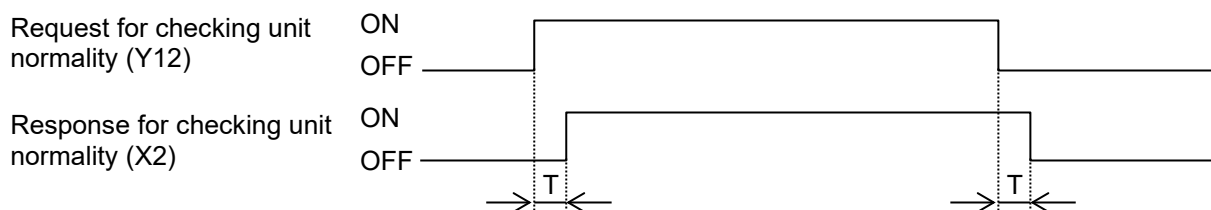

T: response time

- Direct mode : T < 2ms
- Refresh mode : T is depended on the refresh timing.
- Via the network : T is depended on the transmission delay.

(4) Sensor error detection (X4 [X8])

This signal turns ON when an error occurs in ABSOCODER's position detection system, due to a disconnected ABSOCODER cable, etc.

'X4 [X8]' will go OFF when 'Y1C' (error reset signal) turns ON by the sequence program after correcting a cause of the error.

(5) Error detection (X5 [X9])

This signal comes ON when any of the 'X4 [X8]' signal comes ON, or when any of the errors shown section 8.1 occur.

'X5 [X9]' will go OFF when 'Y1C' (error reset signal) turns ON by the sequence program after correcting a cause of the error.

(6) PLC ready signal (Y10)

This signal is used to switch VS-R262BH's operation status (online/offline).

Y10 ON Online

Y10 OFF Offline

*: Current position setting cannot be executed at the "offline" status.

(7) Error reset signal (Y1C)

The following error detection signals will go OFF when 'Y1C' (error reset signal) turns ON by the sequence program after correcting a cause of the error.

X4 [X8] (Sensor error detection)

X5 [X9] (Error detection)

The error code which has been stored in the buffer memory (Address: 7 [1007]) will also be cleared (0) at this time.

Reset of the error detection signals and clearing of the error codes will be effective when the Y1C status changes from OFF to ON. (Detected at leading edge)

Turn OFF 'Y1C' (error reset signal) after confirming that the error detection (X5 [X9]) is OFF.

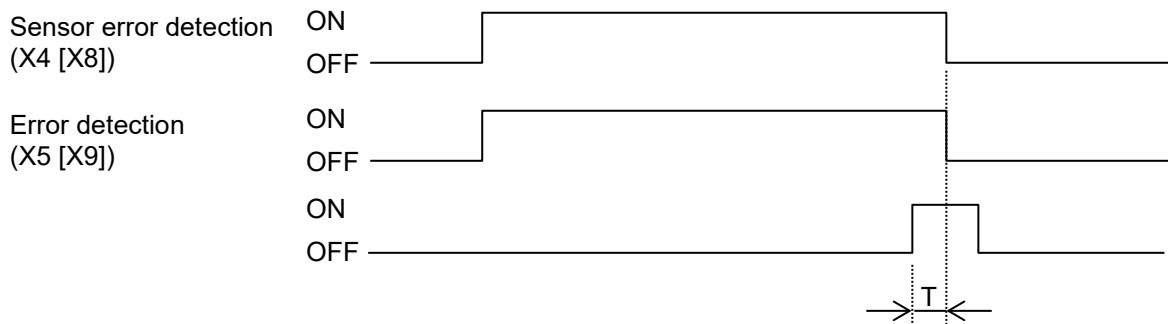

T: response time

- Direct mode : $T < 0.4\text{ms}$

- Refresh mode : T is depended on the refresh timing.

- Via the network : T is depended on the transmission delay.

⚠ NOTES

Do not use a pulse instruction for the 'Y1C' (error reset signal).

ON time of Y1C needs more time than response time "T".

The error detection (X5 [X9]) mightn't go OFF if ON time is short.

(8) Current position setting command (Y13 [Y16])

When Y13 [Y16] is turned ON by the sequence program, the current position setting will be executed. (Detected at leading edge)

This command is only operative at the "online" status.

For details about the current position setting function, refer to Section 5.1.2.

3.5 Buffer Memory

VS-R262BH contains a buffer memory which is used for data communication with the PLC CPU.

Data readout of all areas can be executed by the sequence program.

Buffer memory space is provided for 2 axes (same content).

Addresses 0 to 807 are for axis-1, and addresses 1000 to 1807 are for axis-2.

The 808 to 999 addresses are not used.

Address (decimal) []: Address for axis-2		Writing Conditions
		When designated by sequence program
0[1000]	(L) Sensor value	Writing disabled
1[1001]	(H) (Raw sensor binary value)	
2[1002]	(L) Current position value in CW	
3[1003]	(H) direction (sensor binary)	
4[1004]	(L) Current position value in CCW	
5[1005]	(H) direction (sensor binary)	
6[1006]	Input status	
7[1007]	Error code	
8[1008]	Not used	
689[1689]		
690[1690]	(L) Current position setting value	Writing enabled at any time
691[1691]	(H)	
692[1692]	Not used	
693[1693]		
694[1694]	Current position setting "disabled"	Writing enabled at any time
695[1695]	Not used	
701[1701]		
702[1702]	Axis enabled/disabled	Writing enabled at any time
703[1703]	Not used	
799[1799]		
800[1800]	Inter-module synchronization state	Writing disabled
801[1801]	Not used	
802[1802]	(L) Synchronization sensor value	Writing disabled
803[1803]	(H) (Raw sensor binary value)	
804[1804]	(L) Synchronization current position value in CW direction	
805[1805]	(H) (sensor binary)	
806[1806]	(L) Synchronization current position value in CCW direction	
807[1807]	(H) (sensor binary)	

3.5.1 Sensor value storage area (Address 0, 1 [1000, 1001])

The raw sensor value detected by the ABSOCODER sensor is stored in this area as a binary value.
 The range for raw sensor value is as follows:
 - Multi-turn type MRE: 0 to 131071 (0 to 1FFFFH)
 - The sensor value increases when the input shaft of ABSOCODER sensor rotates in the CW direction.

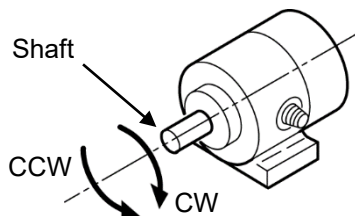

3.5.2 Current position value storage area (Address 2 to 5 [1002 to 1005])

The machine's current position is detected by an absolute method, and that position is stored in this area as a sensor binary value.

Two data areas for the current position value, depending on the direction in which the current position value increases, are as follows:

Current position value in CW direction (Address 2, 3 [1002, 1003]):

The current position value will increase when the sensor shaft rotates in the CW direction as shown below.

Current position value in CCW direction (Address 4, 5 [1004, 1005]):

The current position value will increase when the sensor shaft rotates in the CCW direction as shown below.

The range for current position value is 0 to 131071 (0 to 1FFFFH).

This current position value can be corrected using the current position setting function.
 For details about the current position setting function, refer to Section 5.1.2.

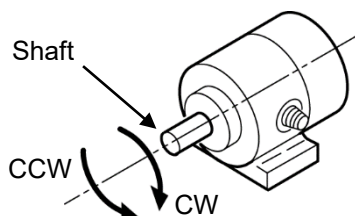

3.5.3 Input status storage area (Address 6 [1006])

This area is used to store the input status of the Current position setting command (Y13 [Y16]).
 The input status is stored as follows:

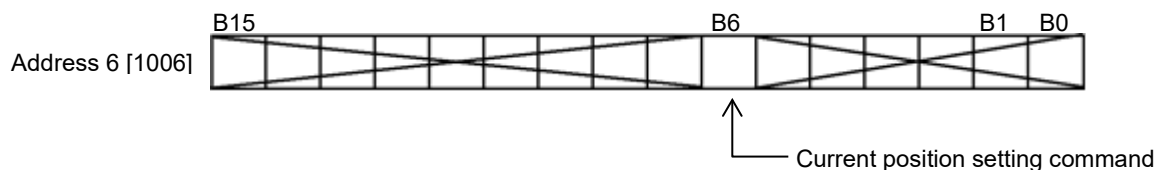

(1) Current position setting command status

When the Current position setting command is ON, '1' is stored.
 '0' is stored at the other bits.

3.5.4 Error code storage area (Address 7 [1007])

This is the area where error codes are stored when errors occur.
For error code details, refer to Section 8.1.

- (1) Error codes are stored as binary values.
- (2) This storage area is cleared by any of the following actions:
 - When turning the Y1C (error reset) signal ON by the sequence program
 - When the PLC CPU is reset
 - When turning ON the PLC power supply again

3.5.5 Current position setting value storage area (Address 690, 691 [1690, 1691])

This is the area where the setting value used for current position value setting by CPU output (Y13 [Y16]) is stored.

This area can be written at any time by the sequence program.

"0" will be stored as default when the following operations are done if the basic setting of the parameter is invalid.

- When the PLC CPU is reset
- When turning ON the PLC power supply again

The setting values are written in binary values.

The setting range is 0 to 131071 (0 to 1FFFFH).

"Error 117" occurs when Y13[Y16] (Current position setting command) of the CPU output is turned ON after writing a value that is out of range.

3.5.6 Current position setting "disabled" area (Address 694 [1694])

This area determines whether or not current position setting by CPU output (Y13 [Y16]) is to occur.

This area can be written at any time by the sequence program.

"0" will be stored as default when the following operations are done if the basic setting of the parameter is invalid.

- When the PLC CPU is reset
- When turning ON the PLC power supply again

- (1) Setting is made by designating '0' or '1' to the appropriate bit:
 - 0: Current position setting command enabled
 - 1: Current position setting command disabled

- (2) As shown below, only one lower bit is active.

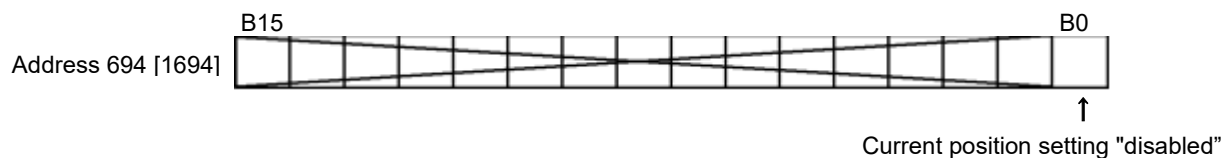

3.5.7 Axis enabled/disabled setting area (Address 702 [1702])

This area determines whether to enable or disable a particular axis.
When buffer memory address 702 is set to "99", the axis-1 will be disabled.
When buffer memory address 1702 is set to "99", the axis-2 will be disabled.
This area can be written at any time by the sequence program.

The value stored in this area isn't changed when the following operations are done if the basic setting of the parameter is invalid.

- When the PLC CPU is reset
- When turning ON the PLC power supply again

The setting values are written in binary values.

- 0 The subject axis will be enabled (factory setting).
- 99 The subject axis will be disabled
(The error will not occur even when the axis is not connected to an ABSOCODER sensor).

NOTES

When an ABSOCODER sensor is connected to an axis set to "99", all the functions except for error detection will work normally.

If adding a sensor after you've set the subject to "99", be sure to set the axis back to "0".
Otherwise, the axis will operate without error detection and will be dangerous.

3.5.8 Inter-module synchronization state storage area (Address 800 [1800])

This area stores whether VS-R262BH is set as "inter-module synchronization target".
The following values are stored;

- 0 No setting
VS-R262BH isn't set as "inter-module synchronization target".
- 1 Setting ("Inter-module synchronous interrupt program" isn't running.)
VS-R262BH is set as "inter-module synchronization target".
- 2 Setting ("Inter-module synchronous interrupt program" is running.)
VS-R262BH is set as "inter-module synchronization target".

Inter-module synchronization state is common to 2 axes; thus, stored values in address 800 and 1800 are the same.

3.5.9 Synchronization sensor value storage area (Address 802, 803 [1802, 1803])

Detected sensor values for each "inter-module synchronization cycle" are stored in this area.
For more details about the inter-module synchronization function, refer to chapter 6.

3.5.10 Synchronization current position value storage area (Address 804 to 807 [1804 to 1807])

Detected current position values (sensor binary value) for each "inter-module synchronization cycle" are stored in this area.
For more details about the inter-module synchronization function, refer to chapter 6.

MEMO

4. HANDLING and WIRING

4. HANDLING and WIRING

This section explains how to unpack and connect VS-R262BH.

4.1 VS-R262BH Handling Precautions

The following precautions should be observed when handling VS-R262BH.

- (1) As VS-R262BH is constructed from a resin-based material, it should not be dropped or subjected to severe shocks.
- (2) Never remove the PCBs from VS-R262BH's case. Failure to do so may result in failure.
- (3) Turn OFF the PLC power supply before mounting and removing VS-R262BH to and from the base unit.
- (4) During the wiring procedure, do not allow any foreign object (e.g. wire strips, etc.) to get into VS-R262BH. The top part of VS-R262BH is particularly vulnerable.
- (5) Tighten the VS-R262BH mounting screws (M3) within the torque range as shown below;
Tightening torque range: 0.36 to 0.48N·m.

4.2 Wiring Precautions for ABSOCODER Cables

The wiring precautions for the ABSOCODER cable are explained in this section.

- (1) The ABSOCODER cable should be located as far as possible from power lines and other lines which generate a high level electrical noise.
- (2) If location near the above power lines is unavoidable, the cable duct should be separated, with individual wiring conduits being provided.
- (3) When wiring conduits are used, they should be securely grounded.

4.3 ABSOCODER Sensor Installation Precautions

The installation conditions and precautions for the ABSOCODER sensor are described in this section.

4.3.1 Installation of ABSOCODER sensor

● Handling of Turn-type ABSOCODER sensor

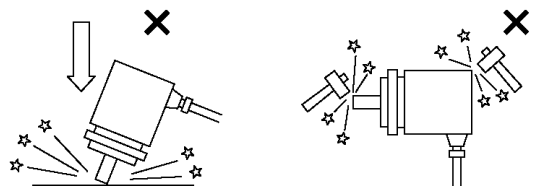
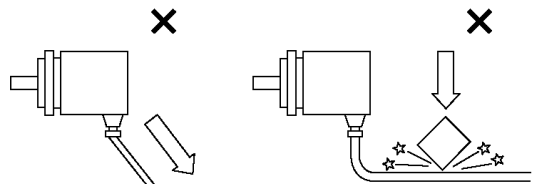
Item	Explanation
1) Main unit	<p>Never drop the Sensor, or subject it to excessive forces or shocks.</p> 
2) Cable	<p>Avoid stepping on, or applying excessive stress to the cable.</p> 

● Mounting of Turn-type ABSOCODER sensor

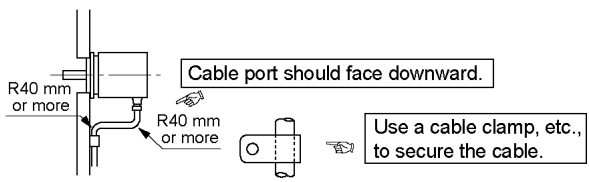
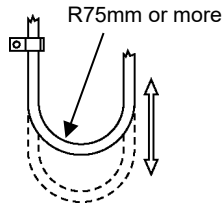
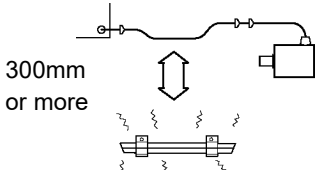
Item	Explanation	Precaution
1) Mounting	For details regarding mounting dimensions, refer to 'Appendix 2.1.2 ABSOCODER Sensor Dimensions'.	
2) Cable port	<p>Cable port should face downward.</p> 	
3) Cable	<p>The bend radius for movable parts should never be less than 75 mm ($\phi 150$) (robotic cable).</p> 	Do not use the standard cable for movable parts. (Use robotic cable.)
4) Wiring	<p>The sensor cable should be located at least 300mm away from power lines and other lines which generate a high level of electrical noise.</p> 	

● Mounting of Turn-type ABSOCODER sensor

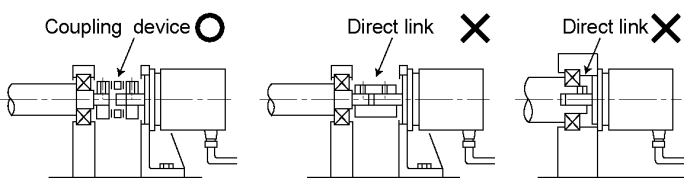
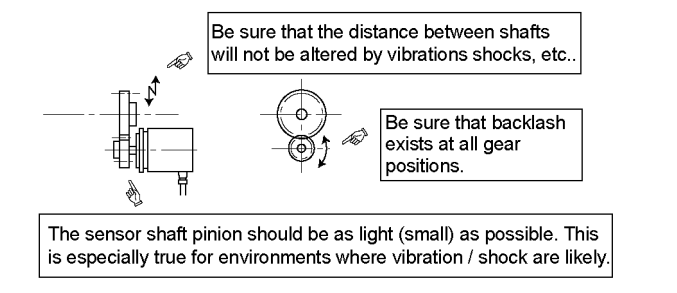
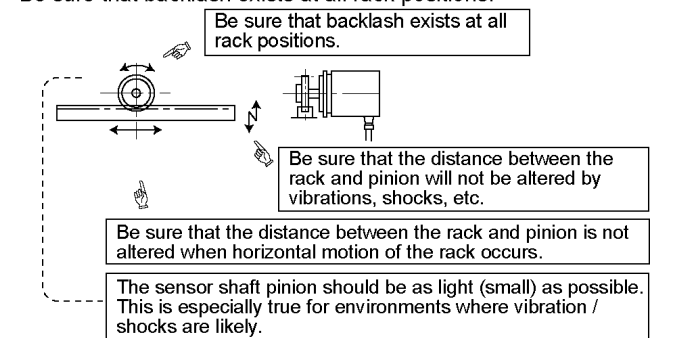
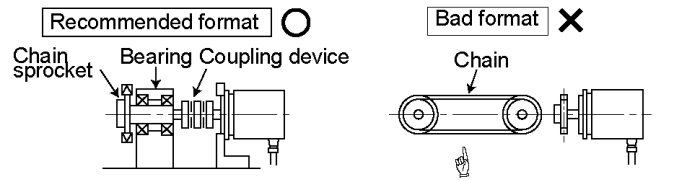
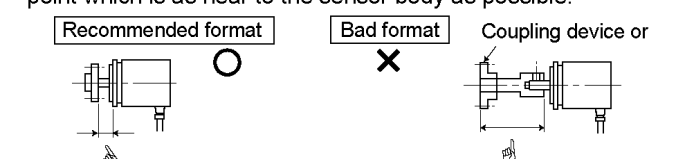
Item	Explanation	Precaution
1) Coupling of machine shaft and sensor shaft	<p>Be sure to use a coupling device to link the 2 shafts.</p> 	<p>A “direct-link” format will result in shaft fatigue and / or breakage after long periods. Therefore, be sure to use a coupling device to link the shafts.</p>
2) For gear-type linkage	<p>If a gear linkage is used, be sure that some backlash exists.</p> 	<p>Incorrect gear mounting can result in shaft bending or breakage.</p>
3) For rack and pinion type linkage	<p>Be sure that backlash exists at all rack positions.</p> 	<p>Incorrect rack and pinion mounting can result in shaft bending or breakage.</p>
4) Chain or timing belt linkage	<p>When a chain or timing belt linkage format is used, there is an inherent risk of the shaft's load being increased by the resulting tension. Therefore, a bearing should be used, with the shafts being linked by a coupling device immediately behind the bearing.</p> 	
5) Shaft mounting position	<p>The shaft should be attached to the coupling device or gear at a point which is as near to the sensor body as possible.</p> 	

● Coupling of Turn-type ABSOCODER sensor

Item	Explanation	Precaution
1) Coupling device selection precaution	<p>1. When selecting a coupling, consider factors such as the design mounting error, the coupling tolerance error, and the sensor's permissible shaft load.</p> <div style="text-align: center;"> <p>Mounting error < Coupling tolerance error < Coupling shaft permissible load < Sensor shaft load</p> <p>Eccentric Deflection Prescribed dimension / Shaft direction displacement</p> <p>Load produced by eccentric condition. Load produced by deflection. Force produced by shaft direction displacement.</p> <p>Radial load Thrust load</p> </div> <p>2. If the selected coupling device is larger than necessary (When used in high vibration/shock environments), the load which is applied to the shaft by the vibrations/shocks will be increased by the weight of the coupling device.</p> <p>3. Be sure to select a coupling device with an adequate transmission torque surplus relative to the sensor shaft's torque.</p>	<p>The selection of a larger coupling than necessary will increase the shaft load which is caused by the mounting error amount.</p> <p>Excessive force applied to the shaft can deform the coupling and reduce durability.</p>
2) Coupling device installation precaution	<p>Avoid bending or damaging the coupling.</p> <div style="text-align: center;"> </div>	

4.3.2 Precautions for connecting ABSOCODER sensors

- (1) Connection should be made using the ABSOCODER cable, with the connector being securely tightened.
- (2) If further length is desired, an extension cable must be ordered separately. Refer to Appendix 2.2 for details regarding extension cables.
- (3) The maximum length for which extension is possible varies according to the ABSOCODER sensor model which is used. Refer to Appendix 2.2.2 for details.
- (4) A robotic cable must be used if the ABSOCODER cable is to be used at a movable area of the system. In such a case, the cable should never be bent to from a radius of less than 75mm.

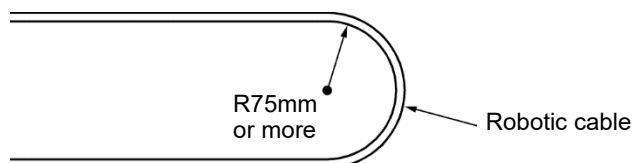

4.4 Name of Parts

The illustration below shows the nomenclature of VS-R262BH.

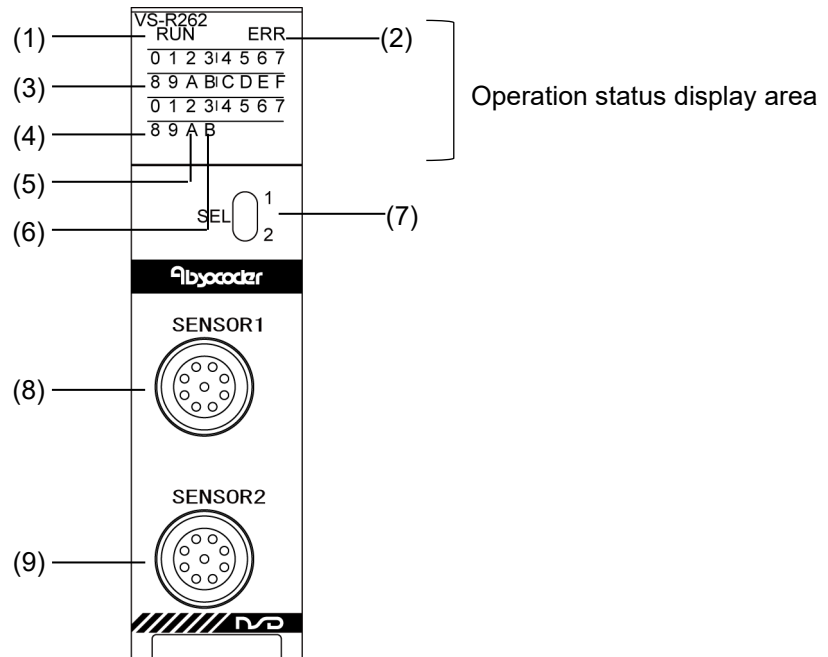

No.	Name	Description
(1)	RUN LED	Displays the operation state of VS-R262BH. ON: Normal operation Blinking (400ms intervals): When selecting a module which is changed online OFF: when the watch dog timer error occurs, when the module can be changed online
(2)	ERR LED	Turns ON or blinks when the error occurs. The type of error is indicated by the manner in which the LED lights. ON: VS-R262BH error Blinking (1s intervals): Sequence program error
(3)	Upper: "0 to F" LED and lower: "0" LED (2 ⁰ ~ 2 ¹⁶ LED)	Indicate the current position value in CW direction (binary code). When an error occurs, the error code (binary code) blinks. The axis to be displayed can be selected using the axis display selection switch.
(4)	Lower: "8" LED (Online LED)	Lights when the VS-R262BH operation status signal (X1) turns ON (online).
(5)	Lower: "A" LED (Axis-1 error LED)	Turns ON or blinks when the axis-1 error occurs. The type of error is indicated by the manner in which the LED lights. ON: VS-R262BH error Blinking (1s intervals): Sequence program error
(6)	Lower: "B" LED (Axis-2 error LED)	Turns ON or blinks when the axis-2 error occurs. The type of error is indicated by the manner in which the LED lights. ON: VS-R262BH error Blinking (1s intervals): Sequence program error
(7)	Axis display selection switch (SEL)	Selects axis indicated on the upper "0 to F" and lower "0" LED.
(8)	Axis-1 sensor connector	Connect the ABSOCODER sensor.
(9)	Axis-2 sensor connector	

MEMO

5. CURRENT POSITION DETECTION FUNCTION

5. CURRENT POSITION DETECTION FUNCTION

5.1 Function Description

5.1.1 Current position detection function

VS-R262BH's current position detection function detects the current position using an ABSOCODER sensor. Conventionally, this was detected using an incremental format encoder in conjunction with a counter unit.

As shown in Figure 5.1, a current position value appropriate for the actual machine position detected by the ABSOCODER sensor is stored in the buffer memory.

Fig. 5.1 Example of using VS-R262BH

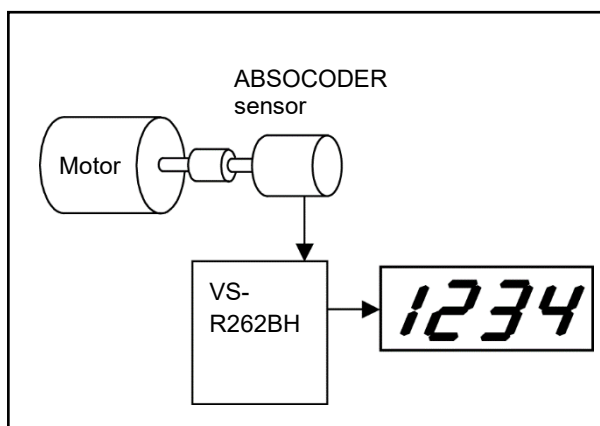

5.1.2 Current position setting function

"Current position setting" is a function to change VS-R262BH's current position value to a value corresponding to the current and actual machine position.

The value in following buffer memory will be changed to a pre-entered current position setting value (Address 690, 691 [1690, 1691]).

- Current position value in CW direction (2, 3 [1002, 1003])
- Current position value in CCW direction (4, 5 [1004, 1005])
- Synchronization current position value in CW direction (804, 805 [1804, 1805])
- Synchronization current position value in CCW direction (806, 807 [1806, 1807])

The following requirements must be satisfied to enable the current position setting function.

- ① A sensor error (error code 22 (H16)) shouldn't be occurred.
- ② VS-R262BH should be in online status.
The device X1 will be turned ON and be in online status when turn ON Y10 by the sequence program.
- ③ The Current position setting disabled area in buffer memory (Address 694 [1694]) should be set to "0".

Setting procedure

- (1) Write a value corresponding to the current and actual machine position into the buffer memory's current position setting value area (Address 690, 691 [1690, 1691]).
Refer to 3.5.5 for details about current position setting value.
- (2) Turn ON the current position setting command (Device Y13 [Y16]) from the PLC CPU.
The current position setting command will be operated at the leading edge.
Do not use a pulse instruction for the current position setting command.
- (3) The current position value will be changed to the given value.
- (4) Turn OFF the current position setting command (Device Y13 [Y16]) after confirming that the current position value is changed.

Current position setting timing

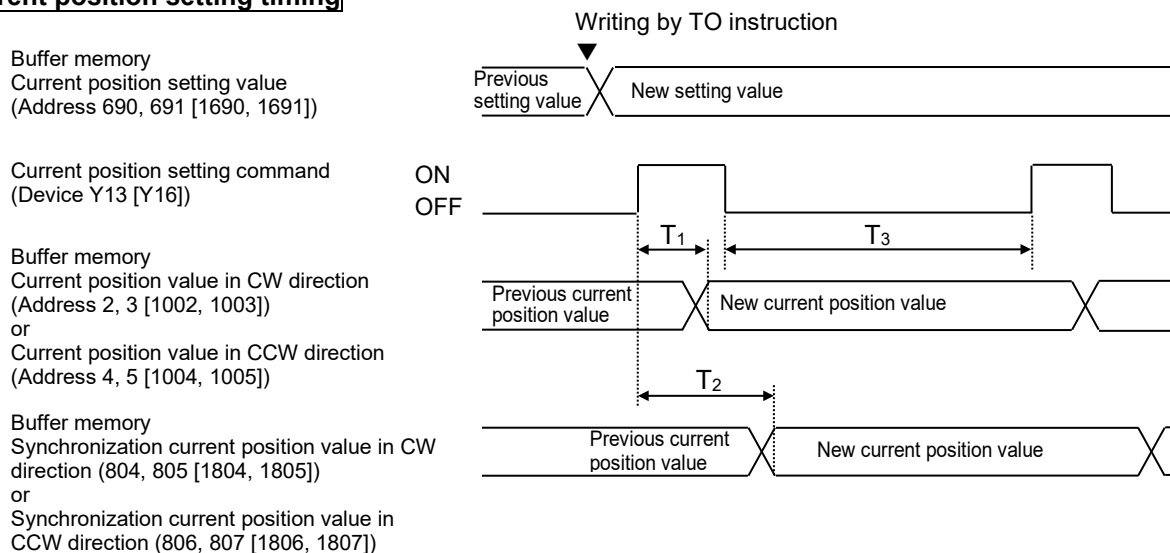

T_1, T_2 : response time

- Direct mode : $T_1 < 0.4\text{ms}$, $T_2 < (0.4\text{ms} + \text{Inter-module synchronization cycle})$
- Refresh mode : T_1 and T_2 are depended on the refresh timing.
- Via the network : T_1 and T_2 are depended on the transmission delay.

T_3 : Current position setting command repeat time

To repeat Current Position Setting Command inputs, the signal must remain OFF for this duration before the second input is made.

$T_3 \geq 100\text{ms}$

5.2 Pre-Operation Setting Sequence

This section explains the setting sequence for the current position detection function.

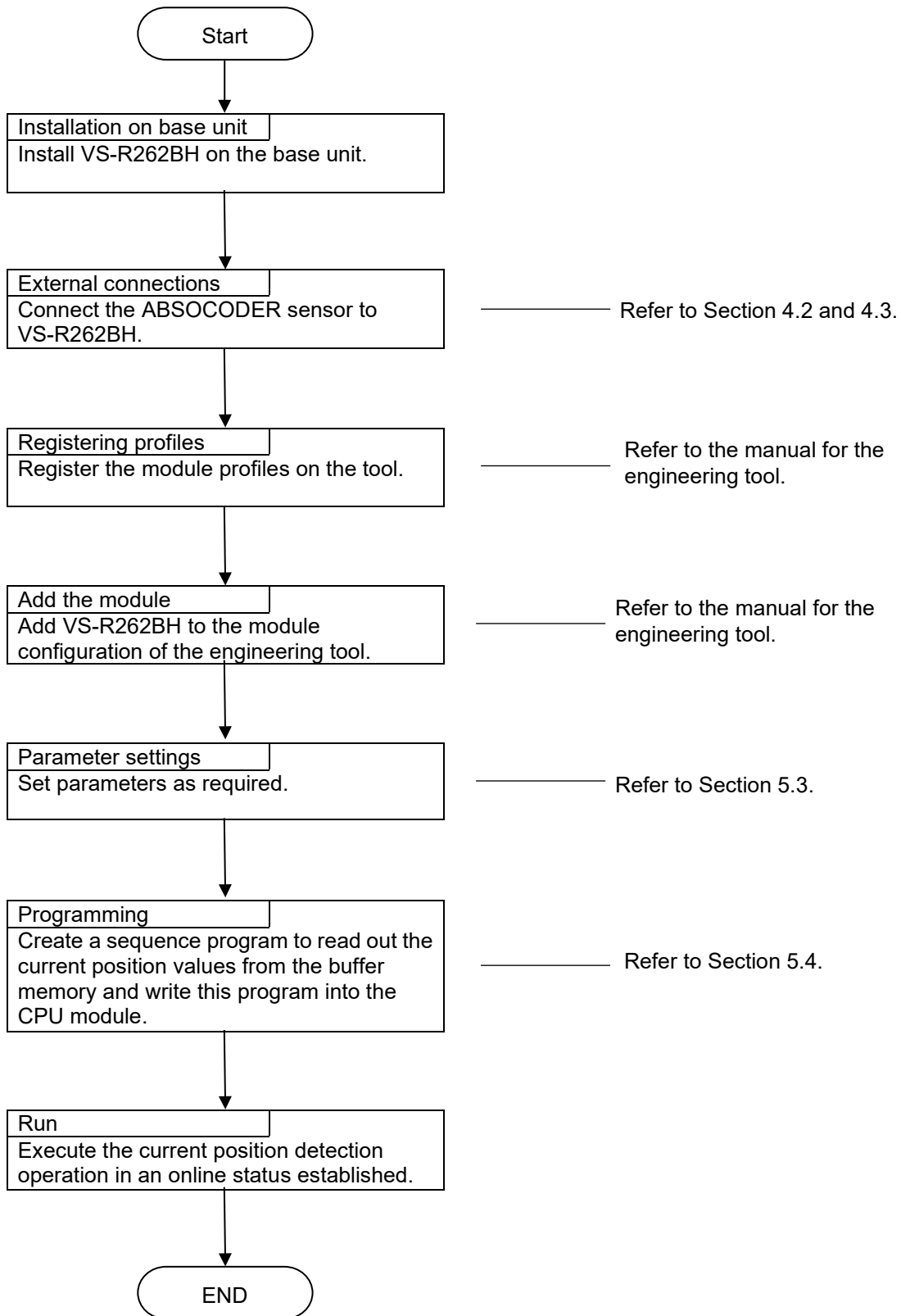

5.3 Parameter Settings

The parameter has two settings "basic and refresh". Set them as required.

This manual indicated examples by using the engineering tool "GX Works3" manufactured by MITSUBISHI ELECTRIC CORPORATION.

5.3.1 Basic settings

The following buffer memories' values can be set.

- Current position setting value (690, 691[1690, 1691])
- Current position setting "disabled" (694 [1694])
- Axis enabled/disabled (702 [1702])

The set value is stored in CPU module.

The value is automatically written from CPU module to buffer memory when following operations are executed;

- When turning ON the PLC power supply.
- When the PLC CPU is reset.

⚠ NOTES

When the current position setting is executed, turn ON the current position setting command (Y13 [Y16]) by using the sequence program after writing a value to the current position setting value (690, 691 [1690, 1691]).

Setting procedure

Follow the procedures below by using the engineering tool.

(1) Open the basic setting of module parameters

"Navigation window" ⇒ "Parameter" ⇒ "Module Information" ⇒ "Module name" ⇒ "Module parameter" ⇒ "Basic Setting"

(2) Set a value for each item.

Item	Axis 1	Axis 2
Current position setting function Current position setting value	This is the area where the setting value used for current position value setting.	
Current position setting "disabled" function Current position setting "disabled"	This area determines whether or not current position setting.	
Axis enabled/disabled setting function Axis enabled/disabled setting	This area determines whether to enable or disable a particular axis.	

Explanation
This is the area where the setting value used for current position value setting.

Buttons: Check, Restore the Default Settings

(3) Write the module parameters in CPU module.

5.3.2 Refresh setting

The value which is stored in the following buffer memory can be transmitted to device of the CPU module automatically.

A device of refresh destination and refreshing timing can be set.

- Sensor value (0, 1 [1000, 1001])
- Current position value in CW direction (2, 3 [1002, 1003])
- Current position value in CCW direction (4, 5 [1004, 1005])
- Input status (6 [1006])
- Error code (7 [1007])
- Inter-module synchronization state (800 [1800])
- Synchronization sensor value (802,803 [1802, 1803])
- Synchronization current position value in CW direction (804, 805 [1804, 1805])
- Synchronization current position value in CCW direction (806, 807 [1806, 1807])

Setting procedure

Follow the procedures below by using the engineering tool.

(1) Open the refresh setting of module parameters

"Navigation window" ⇒ "Parameter" ⇒ "Module Information" ⇒ "Module name" ⇒ "Module parameter" ⇒ "Refresh settings"

(2) Select the refresh destination

-Designates "Top device name" when "Refresh data register (RD)" is selected.
Thus, devices of refresh destinations for each item are set by consecutive numbers.

- Designates devices of refresh destinations for each item when selecting "Device".

- Don't select "Module label".
VS-R262BH isn't for a module label.

(3) Set the refresh timing

Set "Refresh group" when selecting "At the execution time of specified program".

Item	Axis 1	Axis 2
Refresh at the set timing.		
Transfer to the CPU.		
Transfer the buffer memory data to the specified device.		
Sensor value	RD0	RD16
Current position value in CW direction	RD2	RD18
Current position value in CCW direction	RD4	RD20
Input status	RD6	RD22
Error code	RD7	RD23
Synchronous state monitor	RD8	RD24
Refresh Timing		
Set refresh timing.		
Refresh Timing	At the Execution Time of Specified Program	
Refresh Group [n](n: 1-64)	1	
Refresh Timing (I/O)		
Specify the timing which transfers the I/O device data.		
Refresh Timing	When Inter-module Synchronous Interrupt Program Executed	
Inter-module synchronous interrupt function		
Transfer the buffer memory data to the specified device.		
Synchronization sensor value	RD10	RD26
Synchronization current position value in CW direction	RD12	RD28
Synchronization current position value in CCW direction	RD14	RD30
Refresh Timing (Synchronous Interrupt)		
Specify the timing to transfer the data of buffer memory for the Inter-module synchronous interrupt.		
Refresh Timing	When Inter-module Synchronous Interrupt Program Executed	

(4) Write the module parameters in CPU module.

5.3.3 Valid/Invalid of Parameters

Valid or invalid can be selected for the basic and refresh settings.

Setting procedure

Follow the procedures below by using the engineering tool.

(1) Open the module parameter list

[Project] ⇒ [Intelligent Function Module] ⇒ [Module Parameter List]

(2) Set the Valid/Invalid of Basic Setting and Refresh Setting

- The Valid/Invalid of Basic Setting

Check "Initial setting" if the setting is valid.

Uncheck "Initial setting" if the setting is invalid.

- The Valid/Invalid of Refresh Setting

Check "Auto refresh setting" if the setting is valid.

Uncheck "Auto refresh setting" if the setting is invalid.

(3) Write the module parameters in CPU module.

5.4 Programming

This section explains how to create the sequence program using VS-R262BH.

5.4.1 Program creation precautions

- (1) VS-R262BH is an intelligent function module that occupies thirty two I/O points.
- (2) In response to 'FROM/TO' instructions, the first input/output No. of VS-R262BH's slot will be designated.

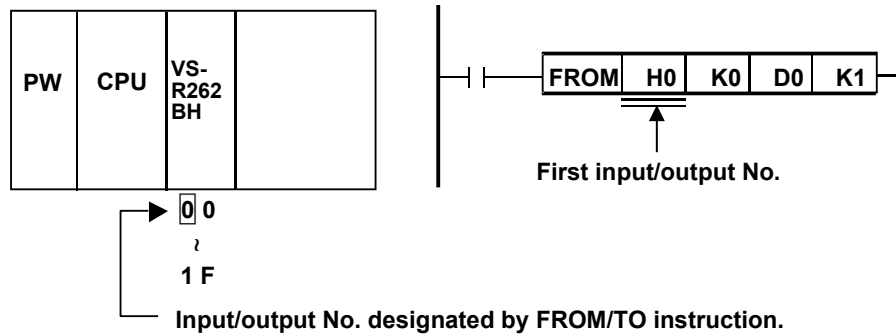

- (3) The following designation enables to execute instructions to VS-R262BH as an intelligent function device.

Designation method: U[]¥G[]

- Buffer memory address
- VS-R262BH's first input/output No.

Setting: When the VS-R262BH first input/output No. is expressed as a 3-digit No., the upper 2 digits are specified.
 When the VS-R262BH first input/output No. begins with 0E0, "0E" is specified. (U0E¥G0).

5.4.2 Program for current position monitor display

A program example for the current position monitor display is given below.
 This program example is for Axis-1. Axis-2 programs can be generated in the same way.

Conditions

The following signal assignments are used to control VS-R262BH.

- VS-R262BH 'online' command X32
- Current position value in CW direction (sensor binary) storage register D0, D1
- Current position value in CW direction (sensor binary) output to external display unit Y60 to Y77

Program example

(1) Example of program using FROM/TO instructions

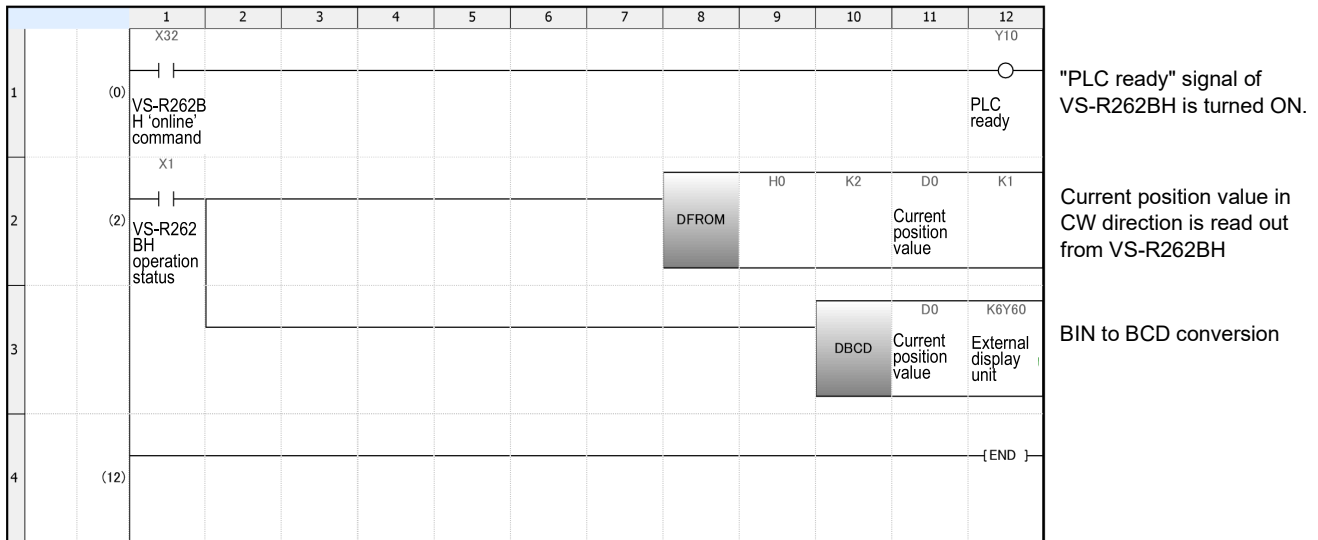

(2) Example of program using an intelligent function device (U[]G[]).

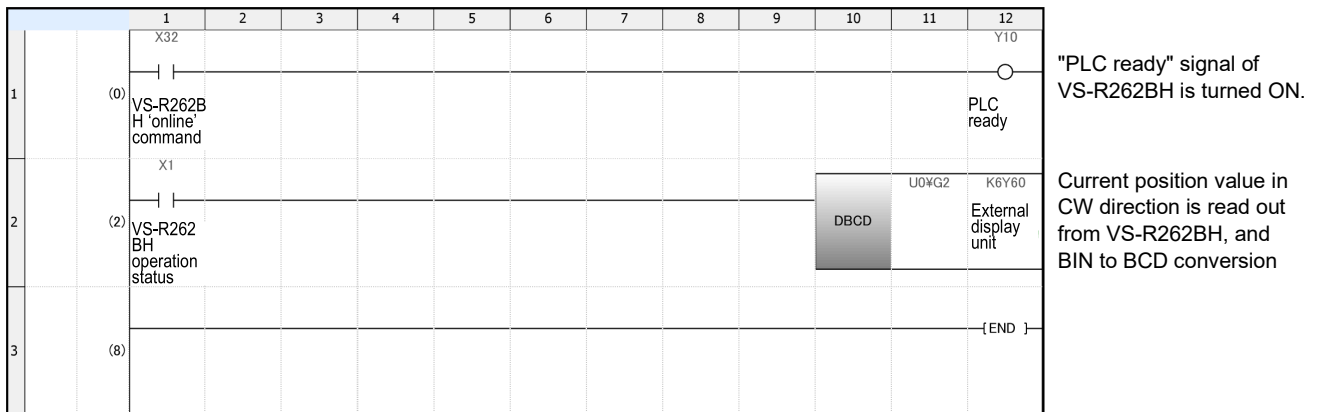

Explanation

- (1) When VS-R262BH is online, the 'X1' signal turns ON.
- (2) The current position value in CW direction is read out from the buffer memory as follows:

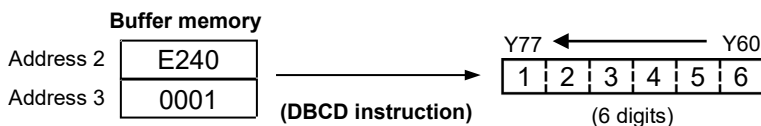

5.4.3 Program for error code readout and error reset

A program example for the error code readout and error reset operation which is used when a VS-R262BH 'error detection' occurs is given below.

This program example is for Axis-1. Axis-2 programs can be generated in the same way.

Conditions

The following signal assignments are used to control VS-R262BH.

- Error code (binary code) storage registerD40
- Output for error code displayY70 to Y7F
- Output for 'error detection' monitorY60
- Output for 'sensor error detection' monitorY61
- VS-R262BH 'online' commandX32
- Error reset signalX50

Program example

(1) Example of program using FROM/TO instructions

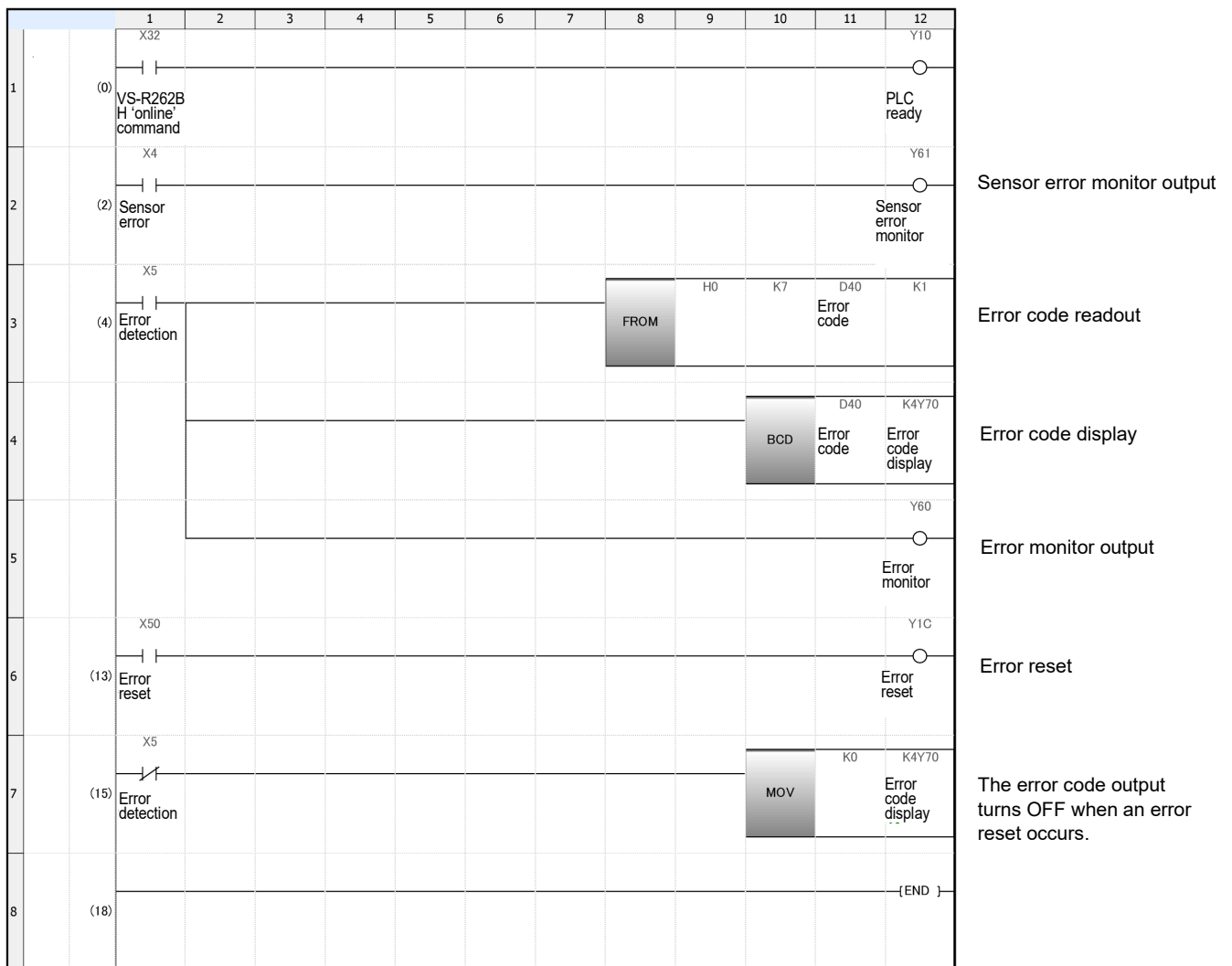

(2) Example of program using an intelligent function device (U[]¥G[]).

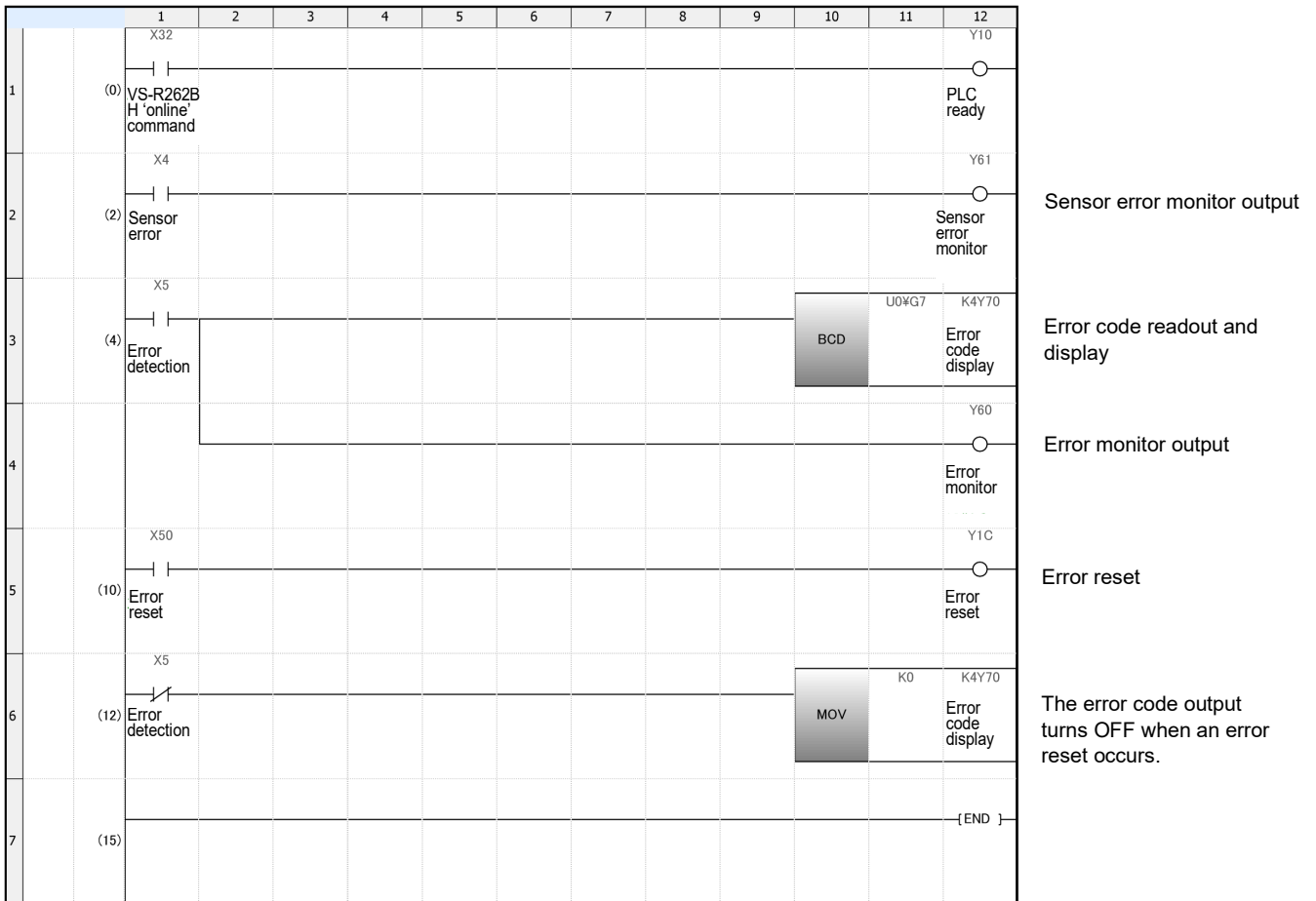

Explanation

- (1) The X4 signal turns ON when a sensor error occurs.
- (2) The X5 signal turns ON when an error occurs.
- (3) The error code is stored at address 7 of the buffer memory as a binary value.
- (4) VS-R262BH errors are reset when the Y1C signal is turned ON.
- (5) The error display is cleared when an error reset occurs.

5.4.4 Program for current position setting

A program example for the current position setting is given below. The current position value is set to 100 in this example.

This program example is for Axis-1. Axis-2 programs can be generated in the same way.

Conditions

The following signal assignments are used to control VS-R262BH.

VS-R262BH 'online' command X32

Current position setting command X33

Program example

(1) Example of program using FROM/TO instructions

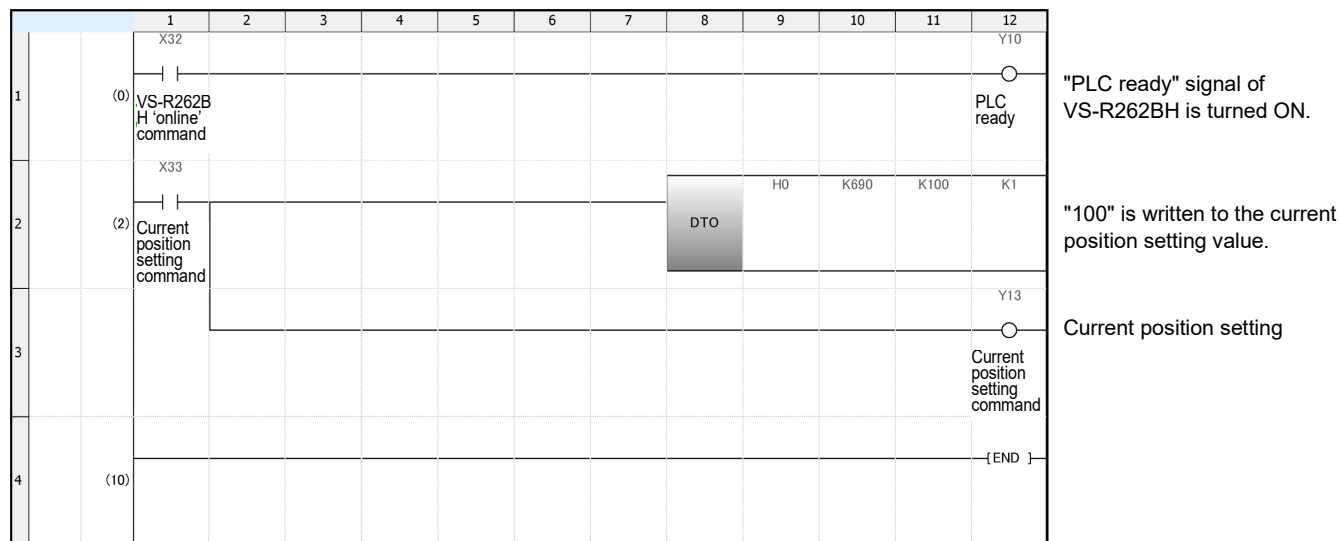

(2) Example of program using an intelligent function device (U[]#G[]).

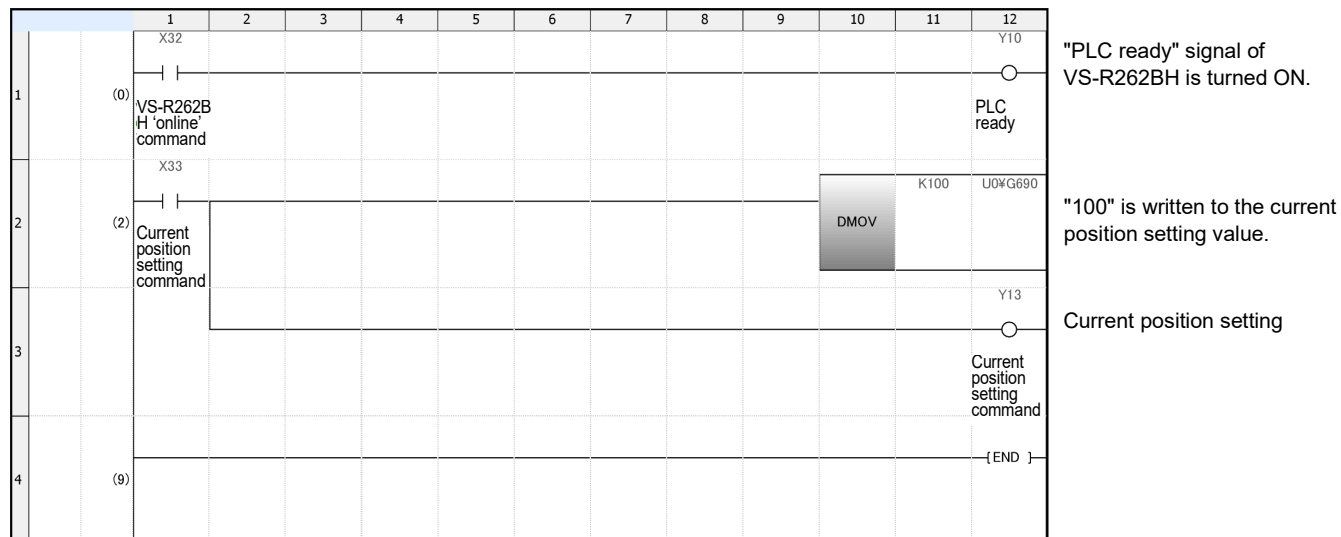

Explanation

- 1) The operation status (X1) of VS-R262BH should be online when setting the current position value. The status is changed to online when turning ON the PLC ready signal (Y10).
- 2) The current position setting value is written to the address 690 and 691 of the buffer memory.
- 3) The current position value setting is done by turning ON the current position setting command (Y13). The following buffer memory values are changed to the values which are set to the address 690 and 691.
 - Current position value in CW direction (2, 3)
 - Current position value in CCW direction (4, 5)
 - Synchronization current position value in CW direction (804, 805)
 - Synchronization current position value in CCW direction (806, 807)

MEMO

6. INTER-MODULE SYNCHRONIZATION FUNCTION

6. INTER-MODULE SYNCHRONIZATION FUNCTION

Synchronous positions can be detected between multiple modules by using "inter-module synchronization function".

6.1 Operation

VS-R262BH detects the positions during T1 time indicated below, and the result is stored in the buffer memory. The stored value is kept until a new value will be stored at the next cycle.

The buffer memory for "inter-module synchronization" is indicated below.

- Synchronization sensor value (802, 803 [1802, 1803])
- Synchronization current position value in CW direction (804, 805 [1804, 1805])
- Synchronization current position value in CCW direction (806, 807 [1806, 1807])

The operation flow of "inter-module synchronization" for 2 modules of VS-R262BH is indicated below.

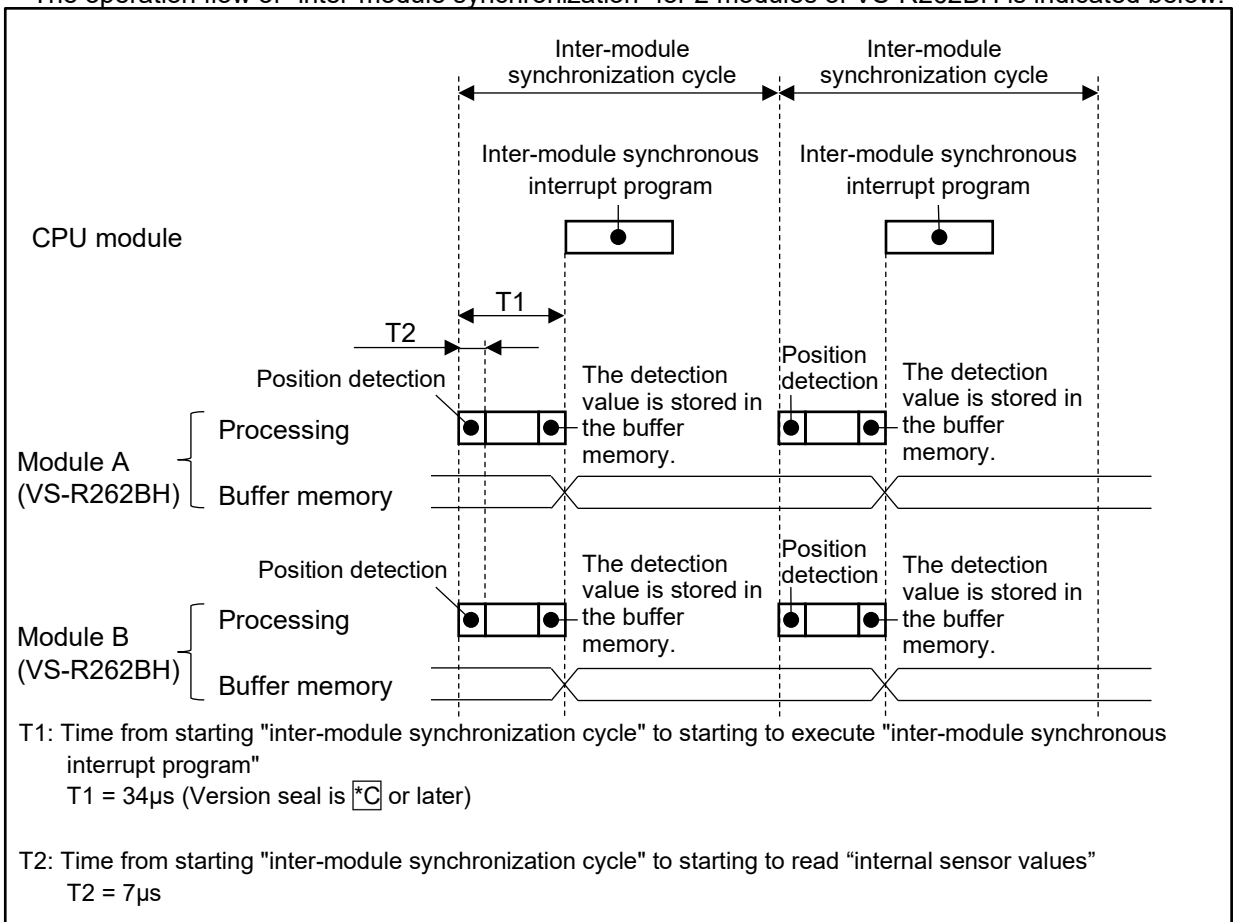

NOTES

A "cycle error for inter-module synchronous interrupt program (I44)" (SM480) occurs when setting "inter-module synchronization cycle" to 0.10ms.

"Inter-module synchronization cycle" should be set to 0.15ms or more.

The "inter-module synchronization cycle" should be set a time that "Inter-module synchronous interrupt program" (I44) or interrupt programs with high priority can be executed.

6.2 Settings

Follow the procedures below by using the engineering tool.

(1) Open the inter-module synchronization setting of system parameters

"Navigation window" ⇒ "Parameter" ⇒ "System Parameter" ⇒
"Inter-module Synchronization Setting"

(2) Set the following items.

- Use Inter-module Synchronization Function in System
Select "Use".

- Select Inter-module Synchronization Target Module
Open the "Detailed Setting". Set "Synchronize" in the setting field for the VS-R262BH.

- Fixed Scan Interval Setting of Inter-module Synchronization
Set the inter-module synchronization cycle.

(3) Write the CPU module in both the system parameters and the module parameters.

For the details about the setting procedures, refer to "MELSEC iQ-R Inter-Module Synchronization Function Reference Manual".

6.3 Readout of the synchronous value

Read out synchronized values (buffer memories written below) by "Inter-module synchronous interrupt program".

- Synchronization sensor value (802,803 [1802,1803])
- Synchronization current position value in CW direction (804, 805 [1804, 1805])
- Synchronization current position value in CCW direction (806, 807 [1806, 1807])

For the detail about the inter-module synchronous interrupt program, refer to the manual of CPU module.

7. ONLINE MODULE CHANGE FUNCTION

7. ONLINE MODULE CHANGE FUNCTION

The module can be changed to a new one without stopping the system during the energization (online). Both of the following methods can change the module online.

- Changing a module using special relays and special registers
- Changing a module directly

For more details about online module change, refer to "MELSEC iQ-R Online Module Change Manual".

NOTES

- The VS-R262BH which is set as "inter-module synchronization target" cannot change the module during the online.
- After the VS-R262BH was changed, find the actual and correct machine position and be sure to correct the current position value using the "Current position setting" function.

7.1 Settings

The following setting must be done in advance when the online module change is executed by the method "changing a module directly".

The setting should be done by using the engineering tools.

This setting isn't needed when the online module change is executed by the method "changing a module using special relays and special registers".

(1) Open the RAS Setting of CPU parameters

"Navigation window" ⇒ "Parameter" ⇒ Module model name ⇒ "CPU Parameter" ⇒ "RAS Setting"

(2) " Set "Enable" to the "direct change setting".

(3) Write CPU parameters in CPU module.

7.2 REPLACEMENT PROCEDURE

7.2.1 Changing a module by controlling special relays and special registers

Replace the VS-R262BH by the following procedures;

(1) Set the SD1600 (base unit No.) and the SD1601 (slot No.)

Ex) In the case of mounting the VS-R262BH on the slot No. 1 of the main base unit; SD1600=0, SD1601=1

(2) Turn ON the SM1600 (Module selection request flag)

The RUN LED of VS-R262BH is blinking (400ms intervals).

(3) Turn ON the SM1602 (Module removal request flag)

The RUN LED of VS-R262BH turns OFF.

(4) Remove the replacing VS-R262BH from the base unit.

(5) Mount a new VS-R262BH on the same slot.

(6) Turn ON the SM1606 (Module recognition request flag)

The RUN LED of VS-R262BH turns ON.

(7) Turn ON the SM1608 (Module control resumption request flag)

The X0 of VS-R262BH (unit ready) turns ON.

Device Y is invalid until the unit ready (X0) turns ON.

7.2.2 Changing a module directly

Replace the VS-R262BH by the following procedures;

(1) Remove the replacing VS-R262BH from the base unit.

(2) Mount a new VS-R262BH on the same slot.

The RUN LED of VS-R262BH turns ON, and also the X0 (unit ready) does.

8. TROUBLESHOOTING

8. TROUBLESHOOTING

VS-R262BH operation errors and troubleshooting procedures are described in this section.

8.1 Error Code List

VS-R262BH error codes are described below.

When VS-R262BH detects an error, the corresponding error code is stored in address 7 [1007] of the buffer memory. At that time the 'error detection' signal (X5[X9]) is turned ON.

At the same time, "ERR" LED and the lower "A [B]" LED lit (blink) on the operation status display area. The error code blinks by the binary code.

Listed below are the possible error codes (with each hexadecimal code in parenthesis).

Error type	LED "ERR" Lower "A[B]"	Error code	Status of device X	Description	When detected	Countermeasure
'Buffer memory writing prohibited' error	Blinks	18 (H12)	X5[X9]: ON	Activated when writing (using the sequence program 'TO' instruction) is attempted in a 'writing prohibited' area of buffer memory.	During online	Revise the sequence program so that writing is not attempted in a 'writing prohibited' area of the buffer memory.
Sensor error	Lit on	22 (H16)	X4[X8]: ON X5[X9]: ON	VS-R262BH detected a sensor error. Possible sensor error causes are as follows: - ABSOCODER sensor is disconnected. - ABSOCODER sensor failure - ABSOCODER cable is severed. - Malfunction at VS-R262BH's internal position detection circuit	Always	- Connect the ABSOCODER sensor. - Replace the ABSOCODER sensor. - Check the electrical condition of the ABSOCODER cable (continuity, shorts). - If the problem appears to be caused by a malfunction at the VS-R262BH internal position detection circuit, please contact your service representative.
Data error	Lit on	69 (H45)	X5[X9]: ON	VS-R262BH detected a memory error.	When power is turned ON.	Each axis should be set as follows; - Current position setting - Axis enabled/disabled Contact your service representative when the error occurs again.
Buffer memory data writing' error	Blinks	117 (H75)	X5[X9]: ON	Activated when incorrect data writing (using the sequence program 'TO' instruction) is attempted in a 'writing enabled' area of the buffer memory. - Current position setting value (Address 690, 691 [1690, 1691])	When current position setting command was executed.	Revise the sequence program so that writing occurs within the prescribed range.
Inter-module synchronization signal error	Lit on	9744 (H2610)	X5[X9]: ON	VS-R262BH detected an error of Inter-module synchronization.	Always	- Take measures to reduce noise. - Reset the CPU module and run it again. If the same error code is displayed again, the possible cause is a hardware failure of the following module. CPU module I/O module Intelligent function module Base unit Extension cable

(1) An error occurs each time the previous error code stored in the buffer memory will be deleted, and replaced by the new error code. The newest error code is always indicated on the LED display.

(2) The error code stored in the buffer memory will not be cleared (returned to '0') simply by correcting the cause of the error.

To clear the buffer memory error code, execute one of the followings:

- Turn Y1C (error reset) signal ON by the sequence program.
- Reset the PLC CPU.
- Turn ON the PLC power supply again.

8.2 Troubleshooting Flowchart

The VS-R262BH troubleshooting procedure is explained below.
For CPU module related problems, consult the manual for the CPU module in question.

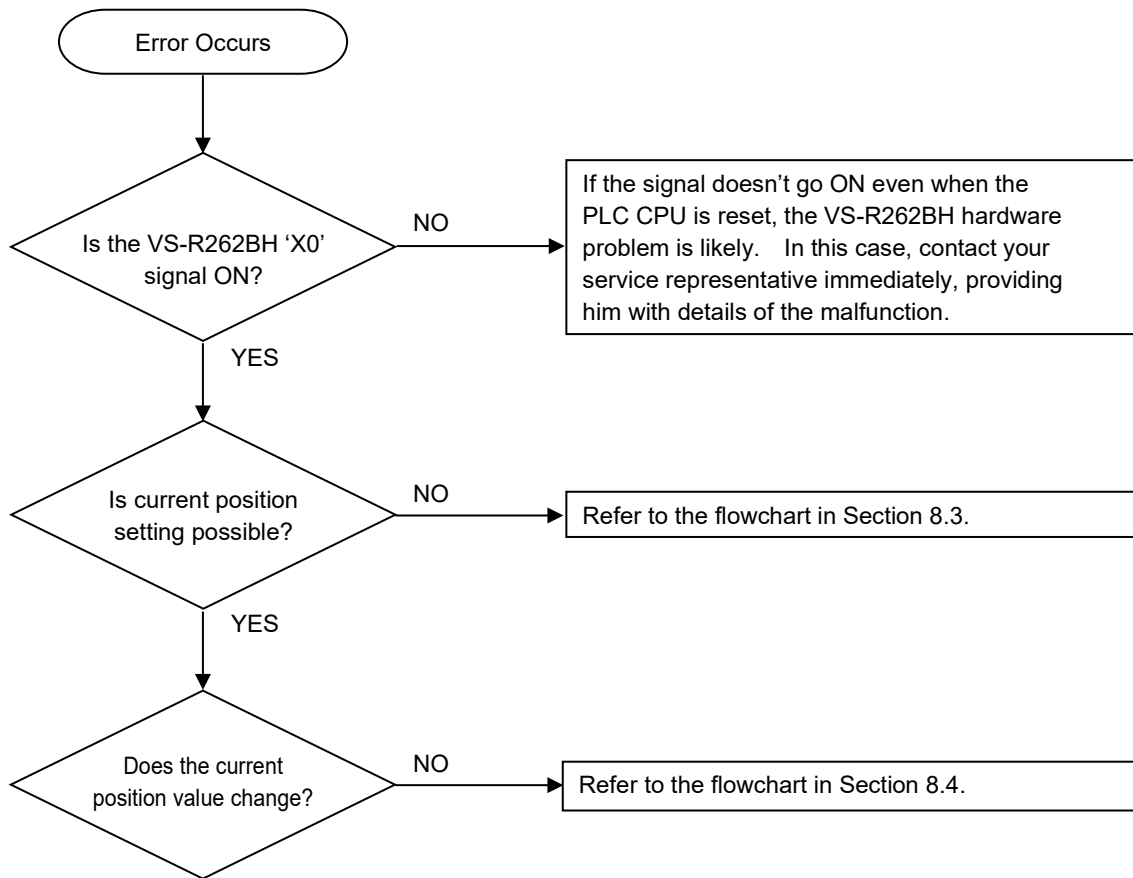

8.3 Flowchart when Current Position Setting is Impossible

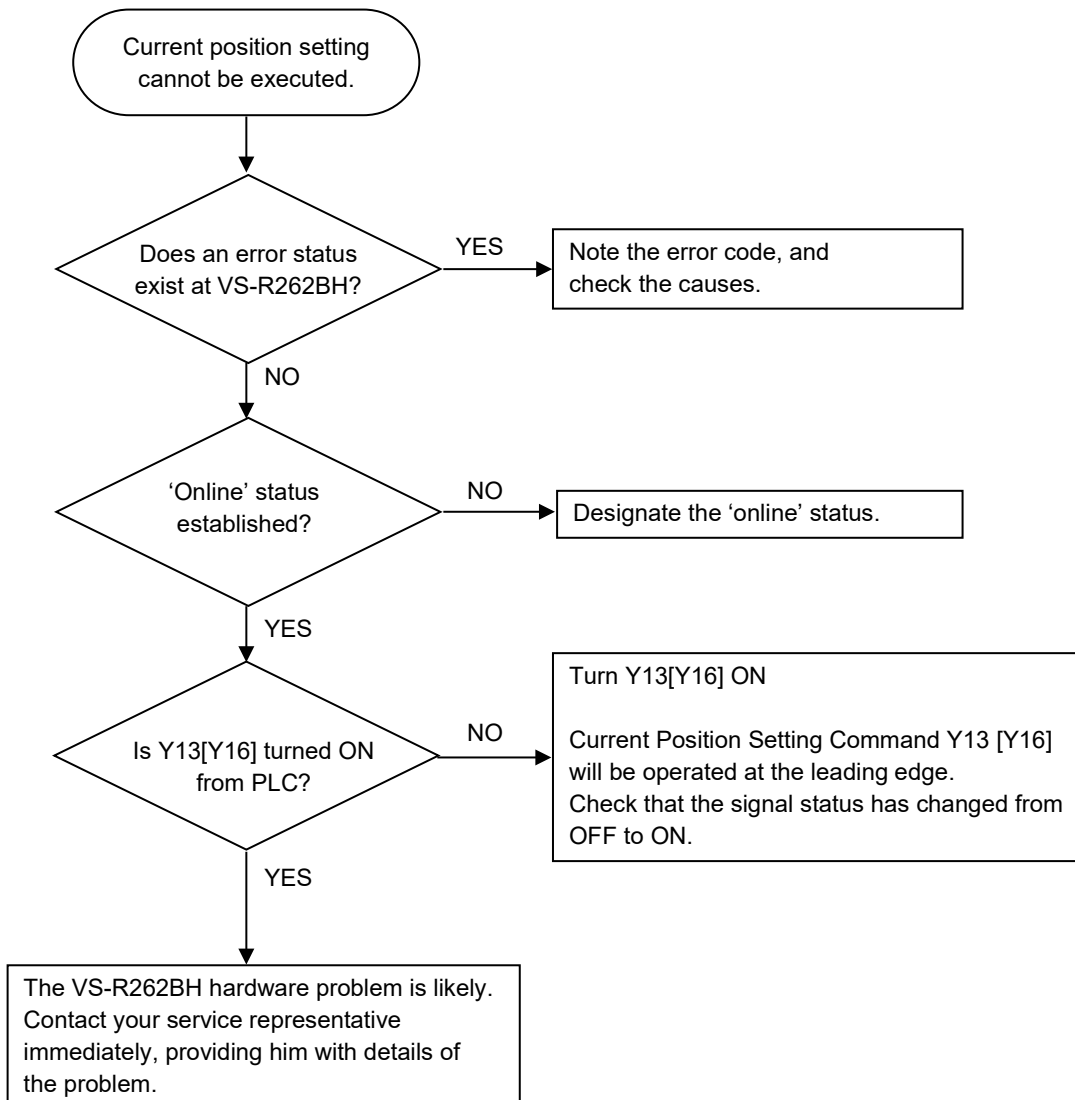

8.4 Flowchart when the Current Position Value doesn't Change

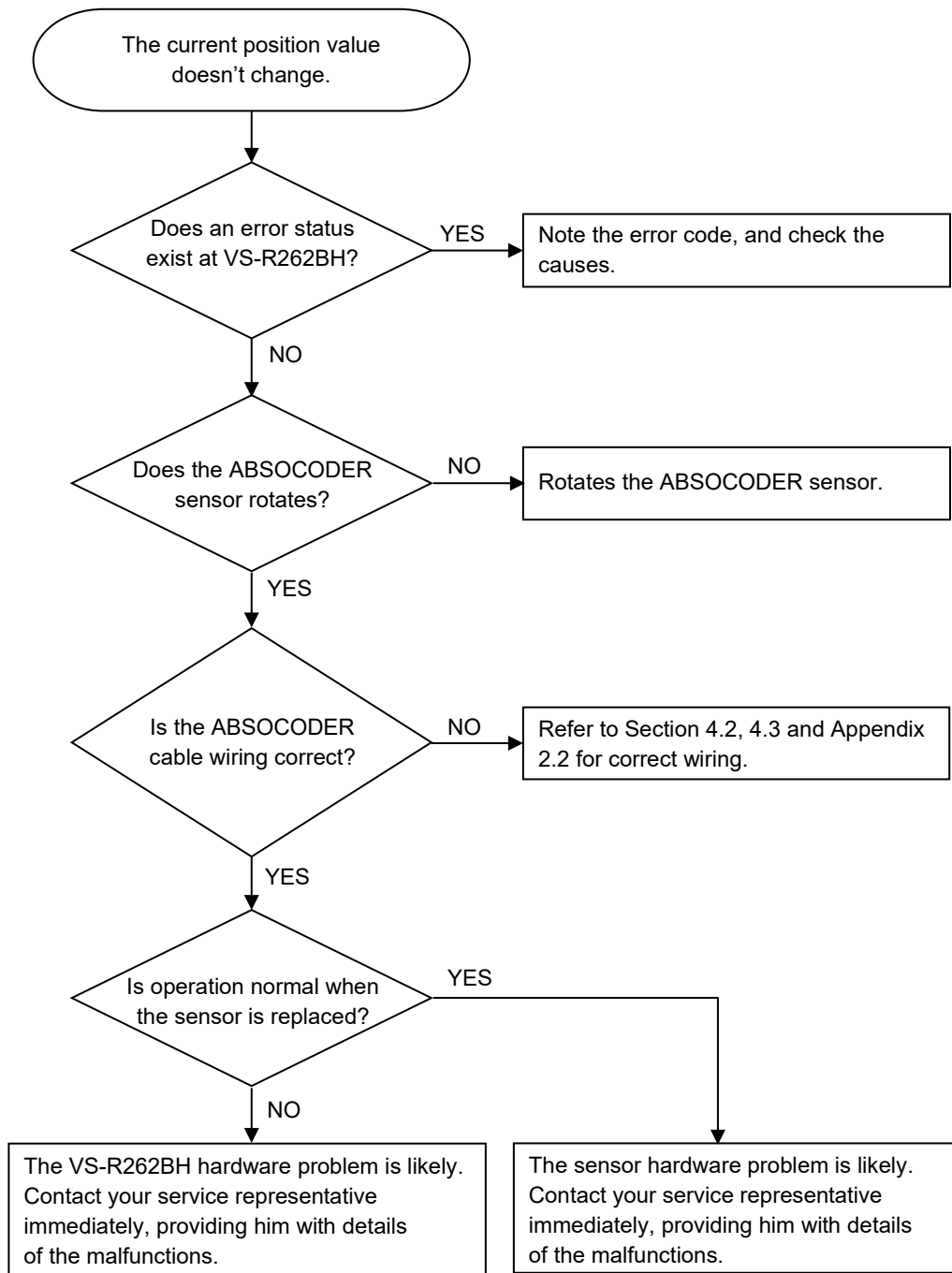

APPENDIX

APPENDIX 1 CE MARKING

The VS-R262BH Series conforms to EMC directive.

APPENDIX 1.1 EMC Directives

It is necessary to do CE marking in the customer's responsibility in the state of a final product. The customer should confirm EMC compliance of the machine and the entire device because EMC changes configuration of the control cabinet, wiring, and layout.

APPENDIX 1.2 EMC Directive and Standards

Conforms to Table 01 (see below) of EMC standards and testing.

Table 01 EMC Standard and Testing

Standard No.	Testing item	Name
EN61131-2	EN61000-6-4	Emission standard for industrial environments
	EN61000-4-2	Electrostatic Discharge
	EN61000-4-3	Radiated, Radio frequency, Electromagnetic Field
	EN61000-4-4	Electrical Fast Transient / Burst
	EN61000-4-5	Surge Immunity
	EN61000-4-6	Conducted Disturbances, Induced by Radio-Frequency Fields
	EN61000-4-8	Power Frequency Magnetic Field

APPENDIX 1.3 Low Voltage Directive

The low voltage directive is out of the range because the VS-R262BH Series is activated by 5VDC power supply.

APPENDIX 1.4 Measures for EMC Compliance and Restriction

A programmable controller must be installed in the control cabinet. Refer to the MELSEC iQ-R Module Configuration Manual for details of the install method.

Install the zippertubing around the cable when the sensor cable is used in 30m or more. The shield of zippertubing should be grounded. Have the zippertubing shield section grounded at the spacious area on the control cabinet. (Do not ground the shield by an electrical wire.)

Recommendation zippertubing

Mounting location	Model	Manufacturer
Sensor cable	MTFS 20 ϕ	ZIPPERTUBING(JAPAN), LTD.

[Reference]

Things may be improved if a clamp ferrite core is added to the extension sensor cable when it operates faultily by the influence from the peripheral device.

Recommendation Clamp Ferrite Core (Product name: Clamp filters for cable)

Mounting location	Clamp ferrite core model	Manufacturer
Extension sensor cable	ZCAT2032-0930 (Inner dimensions: $\phi 9$)	TDK

APPENDIX 2 ABSOCODER SENSOR SPECIFICATIONS

Appendix 2.1 ABSOCODER Sensor for VS-R262BH-M2R

Appendix 2.1.1 Specifications

(1) MRE-[]SP061

Items		Specifications					
Sensor model		MRE-32SP061	MRE-[]SP061				
			[]: Total number of turns, and with a gear(G) or without gear				
			[G64]	[G128]	[G160]	[G256]	[G320]
Total number of turns		32	64	128	160	256	320
Divisions / turn		4096	2048	1024	819.2	512	409.6
Total number of divisions		131072 (2 ¹⁷)					
Mass		1.5kg	1kg				
Linearity error		0.7° Max.	1.4° Max.	2.8° Max.	3.5° Max.	5.6° Max.	7.0° Max.
Moment of inertia GD ² /4(J)		6.7 x 10 ⁻⁶ kg·m ² (6.8 x 10 ⁻⁵ kgf·cm·s ²)	3.9 x 10 ⁻⁶ kg·m ² (4 x 10 ⁻⁵ kgf·cm·s ²)				
Starting torque		4.9 x 10 ⁻² N·m or less (0.5 kgf·cm or less)					
Permissible shaft load	Radial	98N (10 kgf)					
	Thrust	49N (5 kgf)					
Permissible mechanical speed		2000r/min	3600r/min				
Bearing life		4.5×10 ⁴ h (at 2000r/min)	1.5 x 10 ⁴ h (at 3600 r/min)				
Ambient temperature	Operating	-20 to +80°C					
	Storage	-30 to +90°C					
Vibration resistance		2.0 x 10 ² m/ s ² (20G)	98m/s ² (10G)				
		200Hz, up/down 4 h, forward/back 2 h, conforms to JIS D 1601 standard					
Shock resistance		4.9 x 10 ³ m/s ² (500G)	2.9 x 10 ³ m/s ² (300G)				
		0.5 ms, up/down/forward/back x 3 times each, conforms to JIS C 5026 standard					
Protection rating		IP65, conforms to JEM 1030 standard					
Interconnecting cable		2m					
Max. sensor cable length	4P-S	200m	300m				
	4P-RBT/URT/ HRT	100m	150m				
	JKPEV-S (1.25mm ² x 5P)	200m	300m				
Surface treatment		Case: electroless nickel plated Cap: anodic oxide coated	Anodic oxide coated				
Material		Case: steel Cap: aluminum	Aluminum				

(2) MRE-[]SP074

Items		Specifications					
Sensor model		MRE-[]SP074					
		[]: Total number of turns, and with a gear(G) or without gear					
		[32]	[G64]	[G128]	[G160]	[G256]	[G320]
Total number of turns		32	64	128	160	256	320
Divisions / turn		4096	2048	1024	819.2	512	409.6
Total number of divisions		131072 (2 ¹⁷)					
Mass		Flange-mount type: 3.5+0.1 x cable length (m) kg Base-mount type: 5.5+0.1 x cable length (m) kg Face-mount type: 3.0+0.1 x cable length (m) kg					
Linearity error		0.6° Max.	1.2° Max.	2.4° Max.	3.0° Max.	4.8° Max.	6.0° Max.
Moment of inertia GD ² /4(J)		3.3 x 10 ⁻⁵ kg·m ² (3.4 x 10 ⁻⁴ kgf·cm·s ²)					
Starting torque		9.8 x 10 ⁻² N·m or less (1 kgf·cm or less)					
Permissible shaft load	Radial	98N (10kgf)					
	Thrust	49N (5kgf)					
Permissible mechanical speed		4000r/min					
Bearing life		8 x 10 ⁴ h (at 4000r/min)					
Ambient temperature	Operating	-20 to +120°C					
	Storage	-30 to +120°C					
Vibration resistance		2.0 x 10 ² m/s ² (20G) 200Hz, up/down 4 h, forward/back 2 h, conforms to JIS D 1601 standard					
Shock resistance		4.9 x 10 ³ m/s ² (500G) 0.5 ms, up/down/forward/back X 3 times each, conforms to JIS C 5026 standard					
Protection rating		IP67, conforms to JEM 1030 standard					
Interconnecting cable		2 · 5 · 10 · 20m					
Max. sensor cable length	4P-S	300m					
	4P-RBT/URT /HRT	150m					
	JKPEV-S (1.25mm ² x 5P)	300m					
Surface treatment		Not treated					
Material		Stainless					

(3) MRE-[]SP097 / MRE-[]SP101

Items		Specifications										
Sensor model		MRE-[]SP097 / MRE-[]SP101										
		[]: Total number of turns, and with a gear (G) or without gear										
		[32]	[G64]	[G128]	[G160]	[G256]	[G320]	[G512]	[G1280]	[G2048]	*1 [G2560]	*2 [G3072]
Total number of turns		32	64	128	160	256	320	512	1280	2048	2560	3072
Divisions / turn		4096	2048	1024	819.2	512	409.6	256	102.4	64	51.2	42.6
Total number of divisions		131072 (2 ¹⁷)										
Mass		7+0.1 x cable length (m) kg										
Linearity error		0.6° Max.	1.2° Max.	2.4° Max.	3.0° Max.	4.8° Max.	6.0° Max.	9.6° Max.	24 ° Max.	38.4° Max.	48° Max.	56° Max.
Moment of inertia GD ² /4(J)		3.3 x 10 ⁻⁵ kg·m ² (3.4 x 10 ⁻⁴ kgf·cm·s ²)										
Starting torque		9.8 x 10 ⁻² N·m or less (1 kgf·cm or less)										
Permissible shaft load	Radial	1.5 x 10 ² N (15kgf)										
	Thrust	78N (8kgf)										
Permissible mechanical speed		4000r/min										
Bearing life		8 x 10 ⁴ h (at 4000r/min)										
Ambient temperature	Operating	-20 to +120°C										
	Storage	-30 to +120°C										
Vibration resistance		2.0 x 10 ² m/s ² (20G) 200Hz, up/down 4 h, forward/back 2 h, conforms to JIS D 1601 standard										
Shock resistance		4.9 x 10 ³ m/s ² (500G) 0.5 ms, up/down/forward/back X 3 times each, conforms to JIS C 5026 standard										
Protection rating		IP67, conforms to JEM 1030 standard										
Interconnecting cable		2 · 5 · 10 · 20m										
Max. sensor cable length	4P-S	300m										
	4P-RBT/URT /HRT	150m										
	JKPEV-S (1.25mm ² x P)	300m										
Surface treatment		MRE-[]SP097: coated (epoxy resin) MRE-[]SP101: not treated										
Material		MRE-[]SP097: spheroidal graphite iron castings MRE-[]SP101: stainless										

*1: MRE-G2560SP097 and MRE-G3072SP097 cannot be selected.

Appendix 2.1.2 ABSOCODER Sensor Dimensions

(1) MRE-32SP061FK[] (Flange-mounting type)

Units: mm

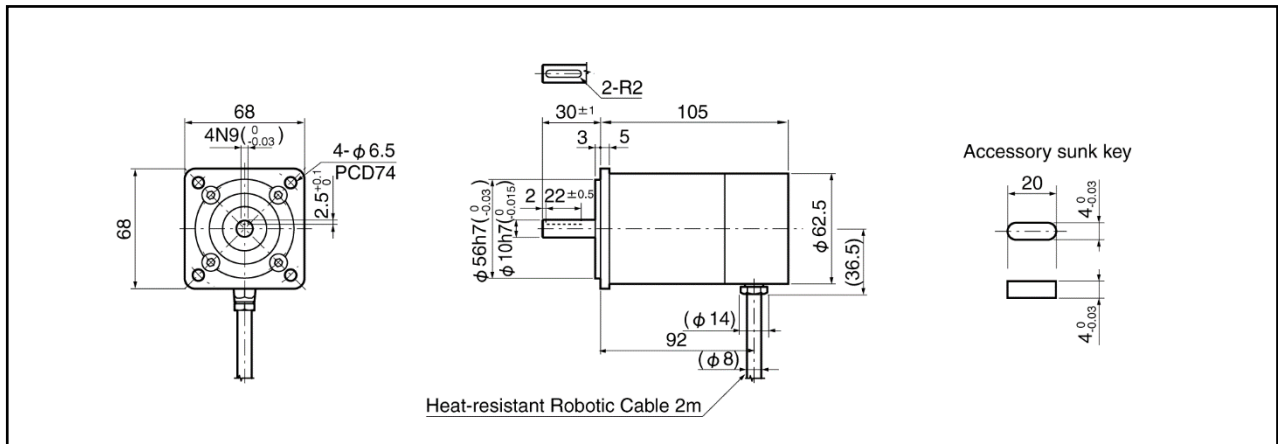

(2) MRE-G[]SP061FK[] (Flange-mount type)

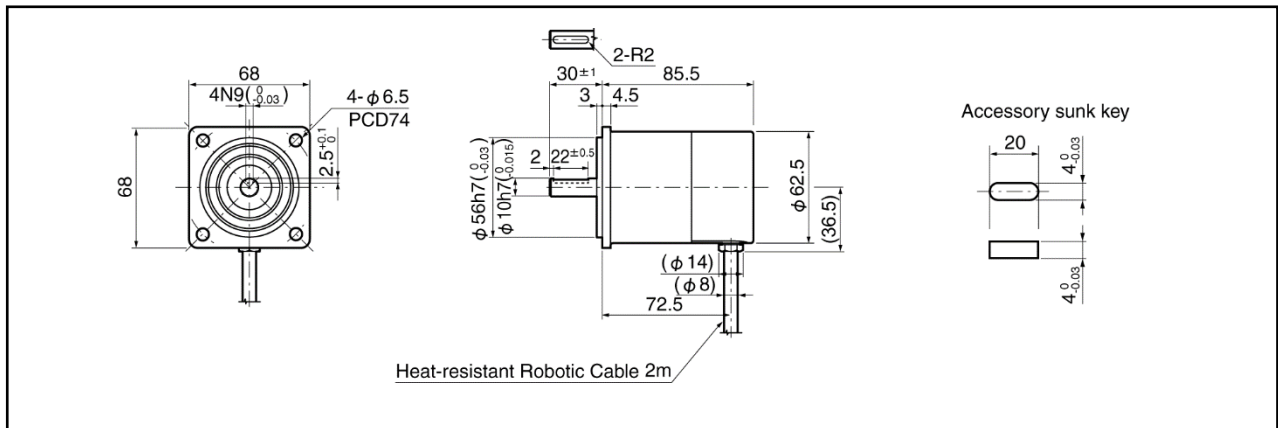

(3) MRE-[]SP074FK[]]-G (Flange-mount type)

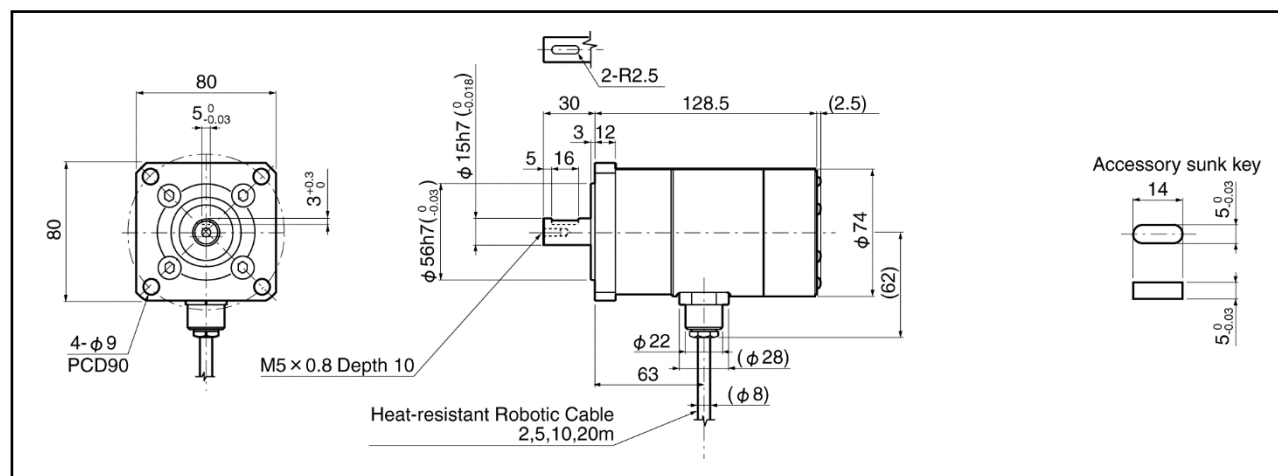

(4) MRE-[]SP074LK[]-G (Base-mount type)

Units: mm

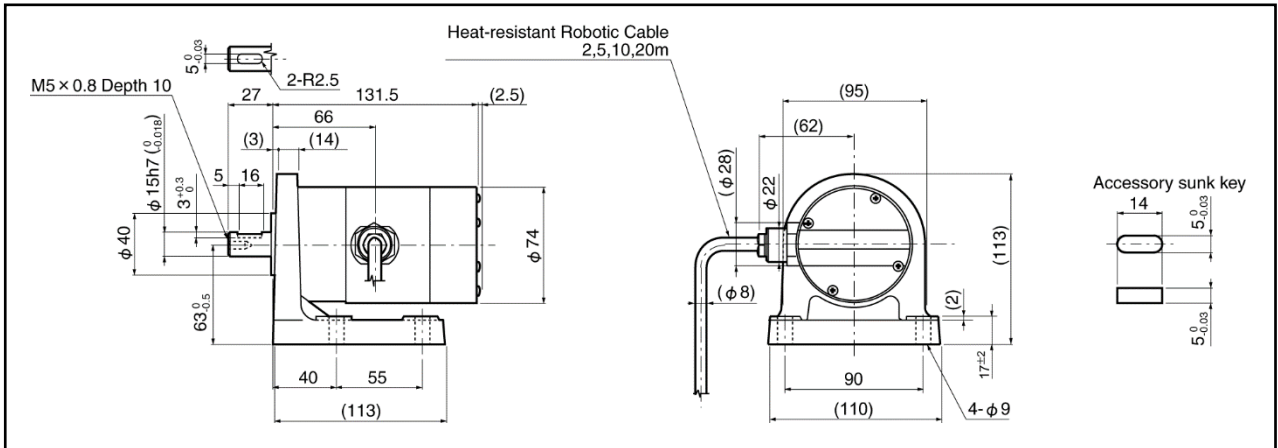

(5) MRE-[]SP074MK[]-G (Face-mount type)

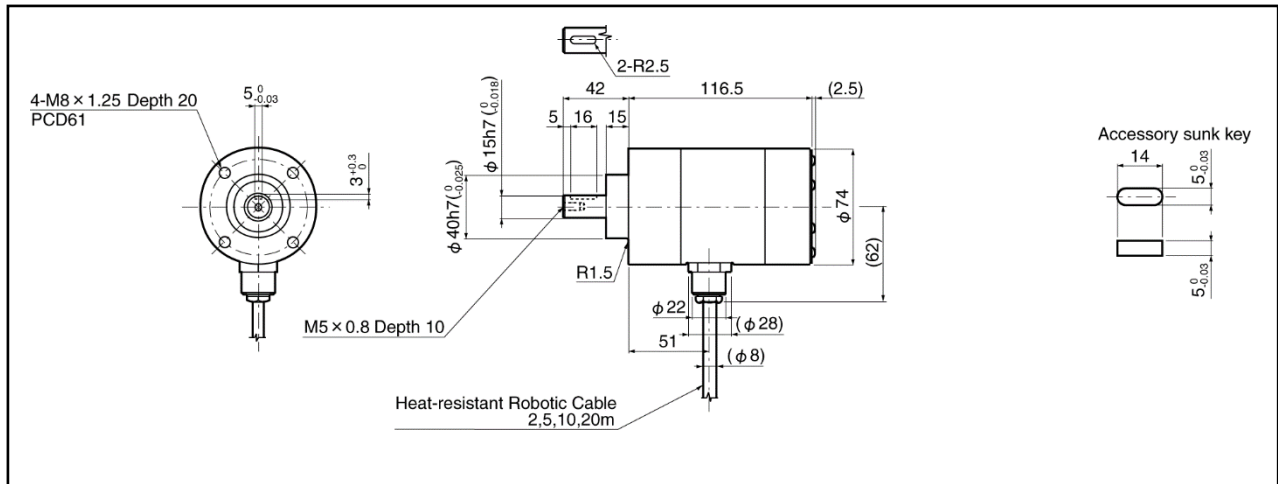

(6) MRE-[]SP097FK[]-G (Flange-mount type)

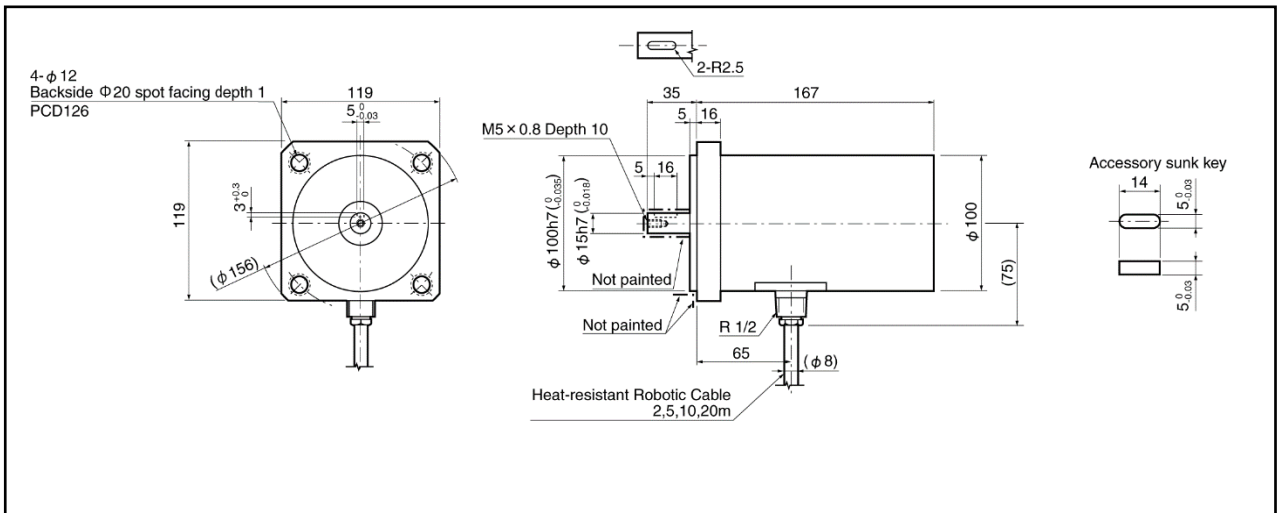

(7) MRE-[]SP097LK[]-G (Base-mount type)

Units: mm

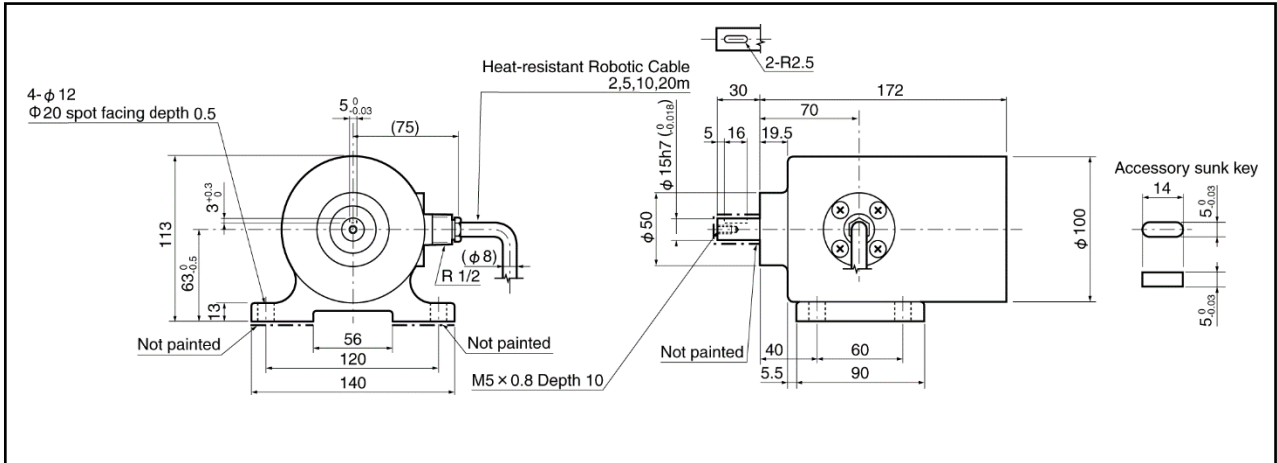

(8) MRE-[]SP101FK[]-G (Flange-mount type)

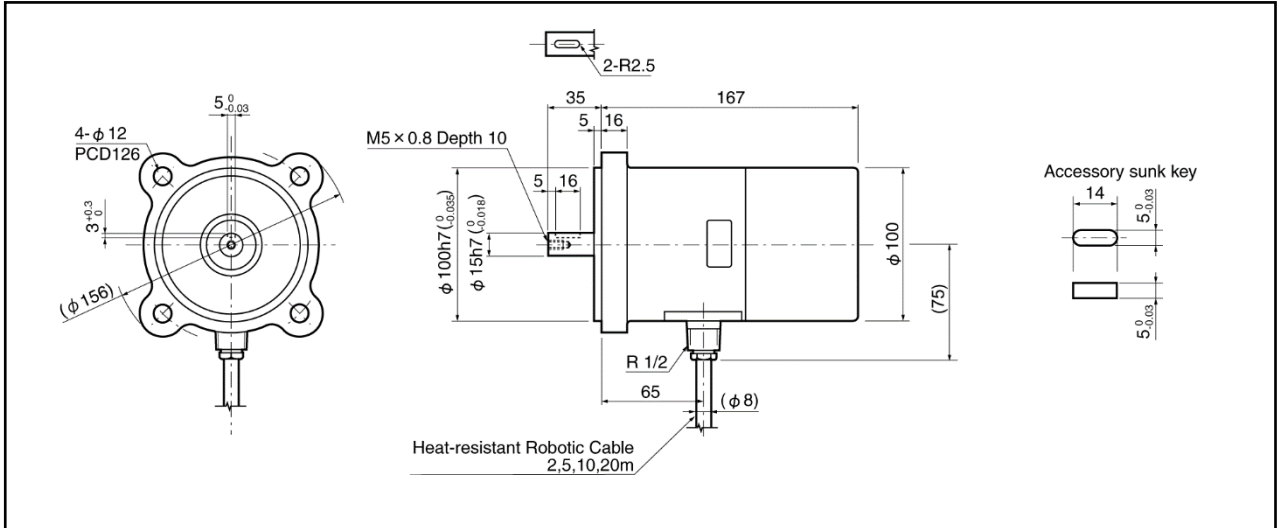

(9) MRE-[]SP101LK[]-G (Base-mount type)

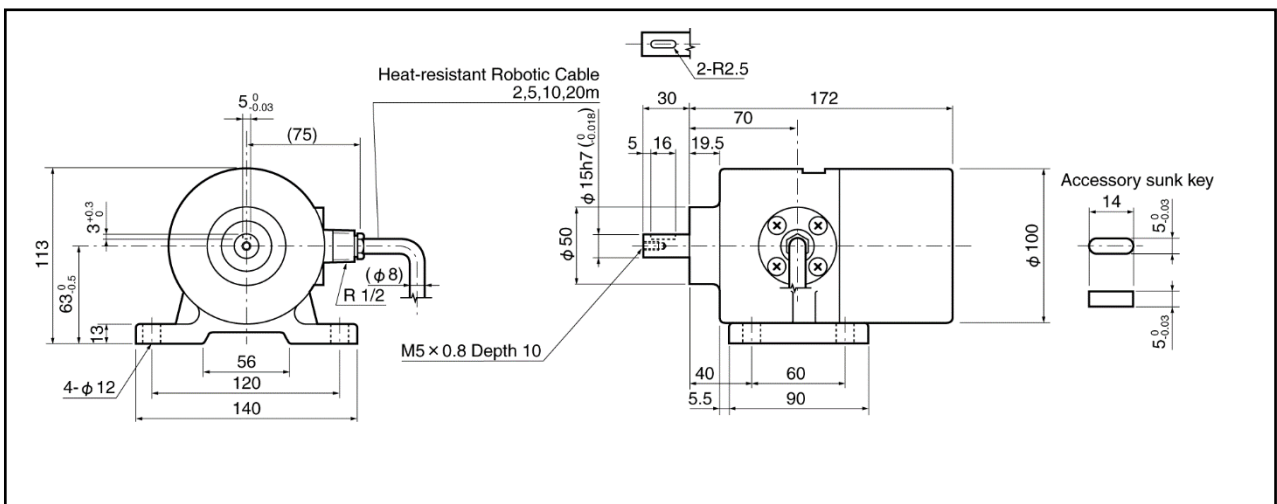

Appendix 2.2 ABSOCODER Cable

Appendix 2.2.1 Specifications

Items	Specifications			
Model code	4P-S	4P-RBT	4P-URT	4P-HRT
Cable type	Standard cable	Robotic cable	Semi-heat-resistant robotic cable	Heat-resistant robotic cable
Diameter	$\phi 8$			
Operating temperature range	-5~+60°C		-5~+105°C	0~+150°C
Insulator	Irradiated cross linked formed polyethylene	ETFE plastic (resin)		
Sheath	Polyvinyl chloride mixture		Heat-resistant polyvinyl chloride mixture	Fluonlex
Construction	8-core, 2 pairs without shield + 2 pairs with shield			
Color of sheath	Gray	Black		
Advantage	Extensible for long distances	Superior flexibility; ideal for moving place		Heat treatment and flexible; ideal for moving place

Appendix 2.2.2 Cable length restrictions

The permissible length of the ABSOCODER cable varies according to the ABSOCODER sensor model, as shown in the following table.

Cable model \ Sensor model	Cable model		
	4P-S	4P-RBT 4P-URT 4P-HRT	JKPEV-S (1.25mm ² × 5P)
MRE- 32SP061	200m	100m	200m
MRE-G[]SP061	300m	150m	300m
MRE- 32SP074 MRE-G[]SP074 MRE- 32SP097 MRE-G[]SP097 MRE- 32SP101 MRE-G[]SP101	300m	150m	300m

REMARKS

Contact your NSD representative when the ABSOCODER cable combines different types of cables.

Appendix 2.2.3 ABSOCODER Cable Dimensions

(1) 4P-S-0144-[L] / 4P-RBT-0144-[L] / 4P-URT-0144-[L]

Units: mm

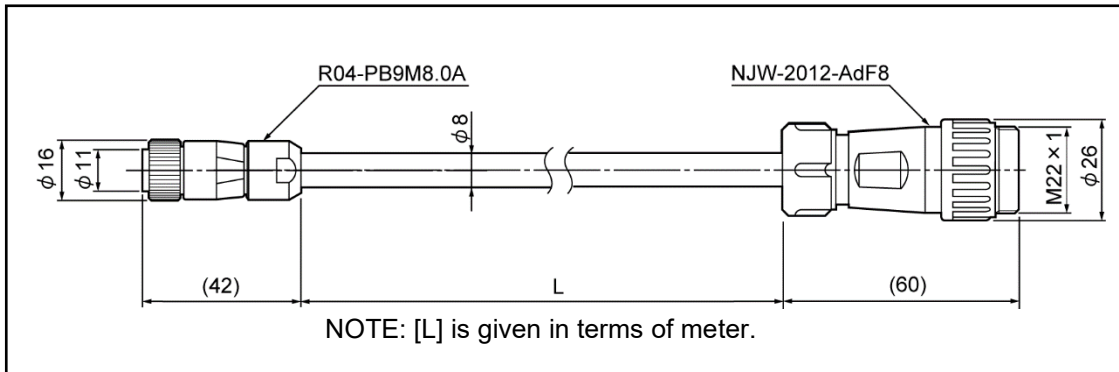

(2) 4P-S-4344-[L] / 4P-RBT-4344-[L] / 4P-URT-4344-[L] / 4P-HRT-4344-[L]

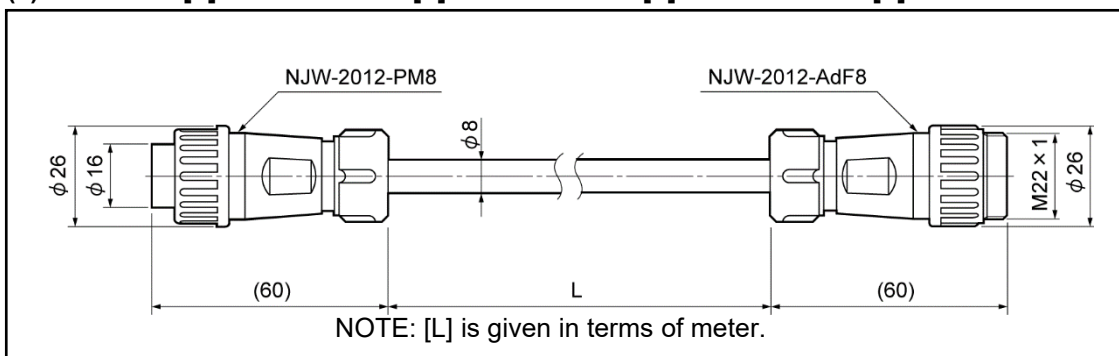

(3) 4P-S-0155-[L] / 4P-RBT-0155-[L] / 4P-URT-0155-[L]

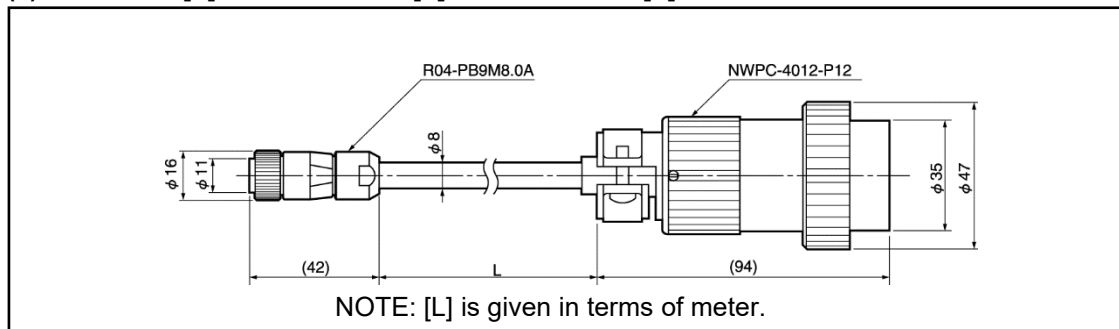

(4) 4P-S-0190-[L] / 4P-RBT-0190-[L] / 4P-URT-0190-[L]

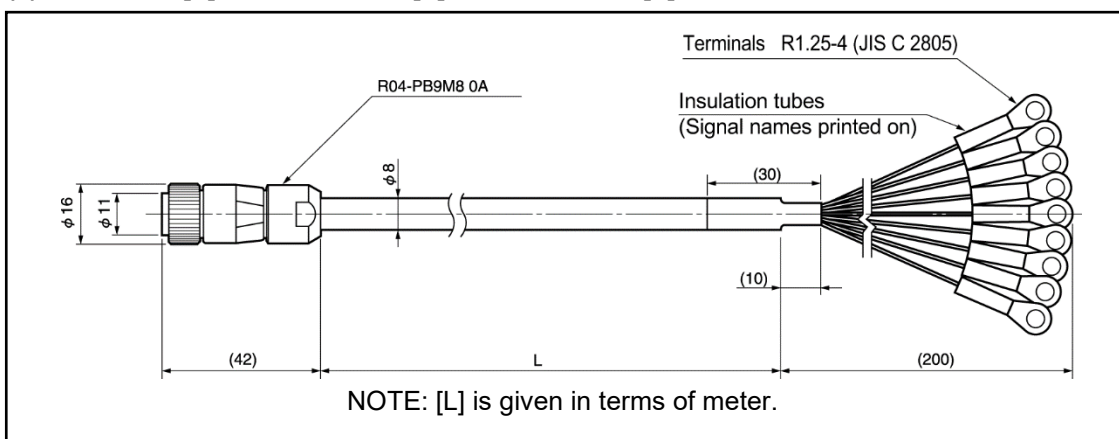

Appendix 2.2.4 ABSOCODER Cable Connection

(1) In the case of using the NSD special cable

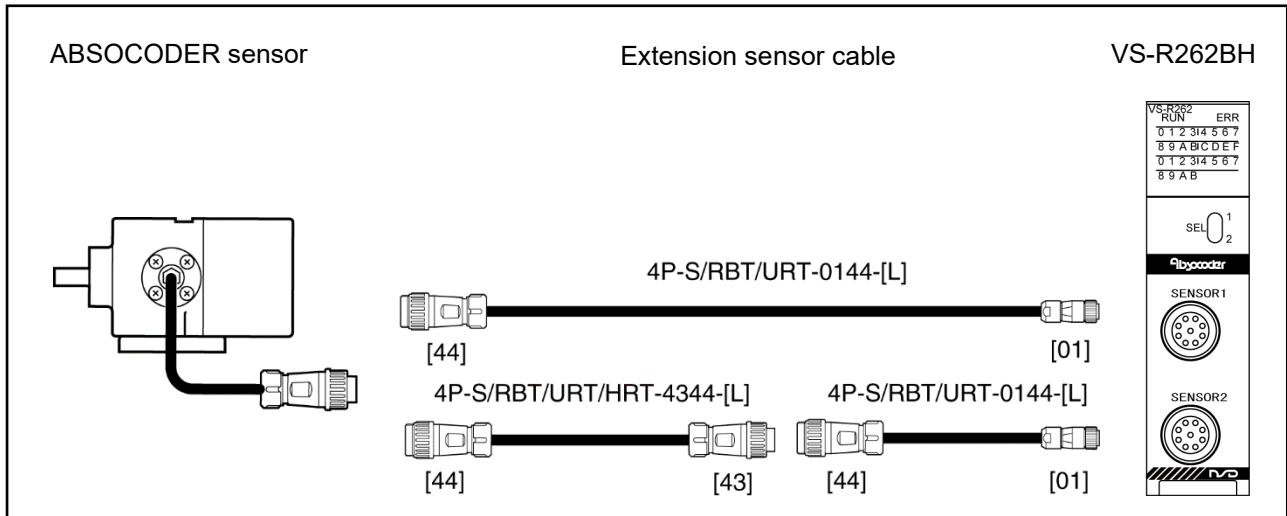

(2) In the case of using the commercially available cable (JKPEV-S 1.25mm²x5P) and connecting with crimping terminals

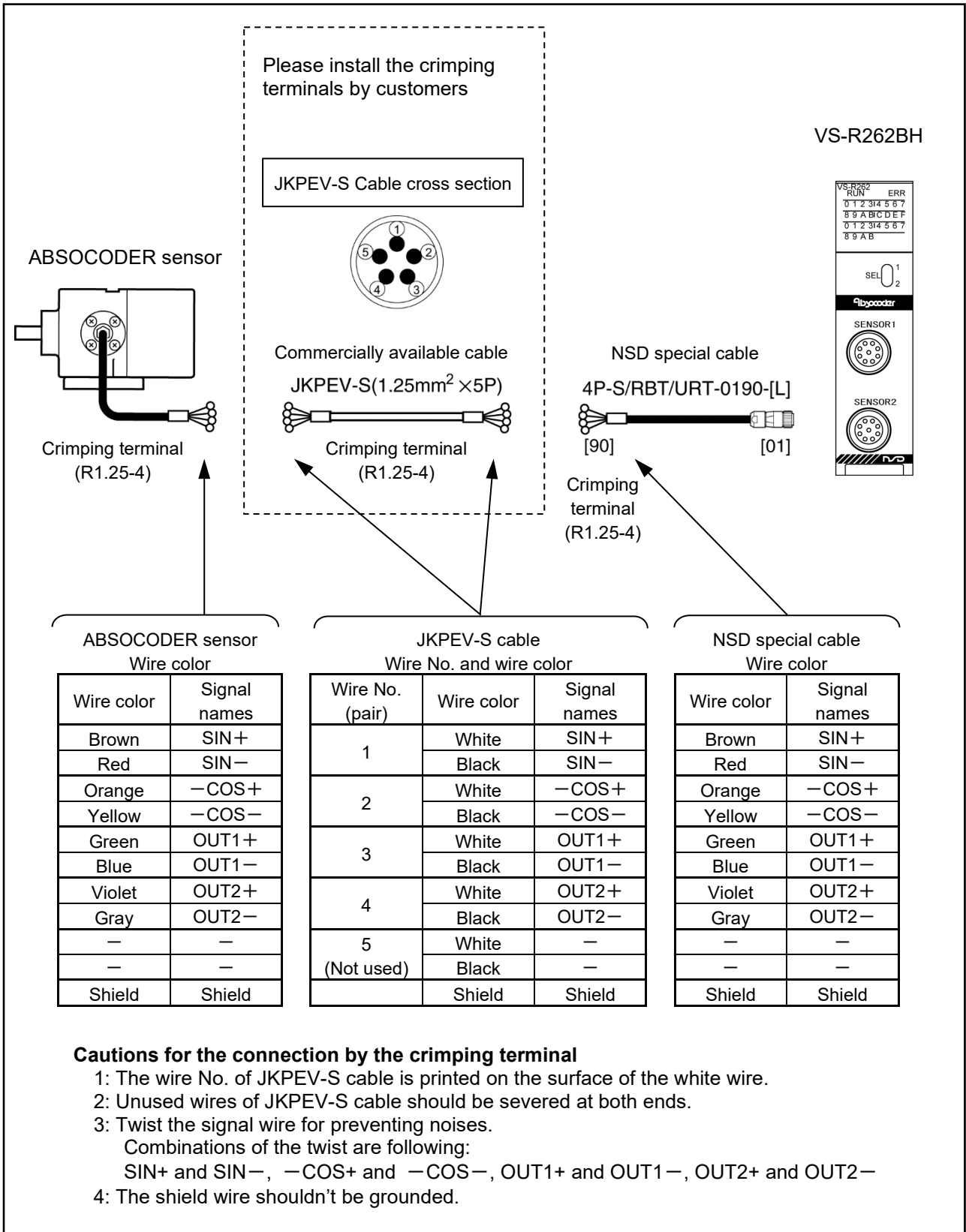

(3) In the case of using the commercially available cable (JKPEV-S 1.25mm²×5P) and connecting with a connector

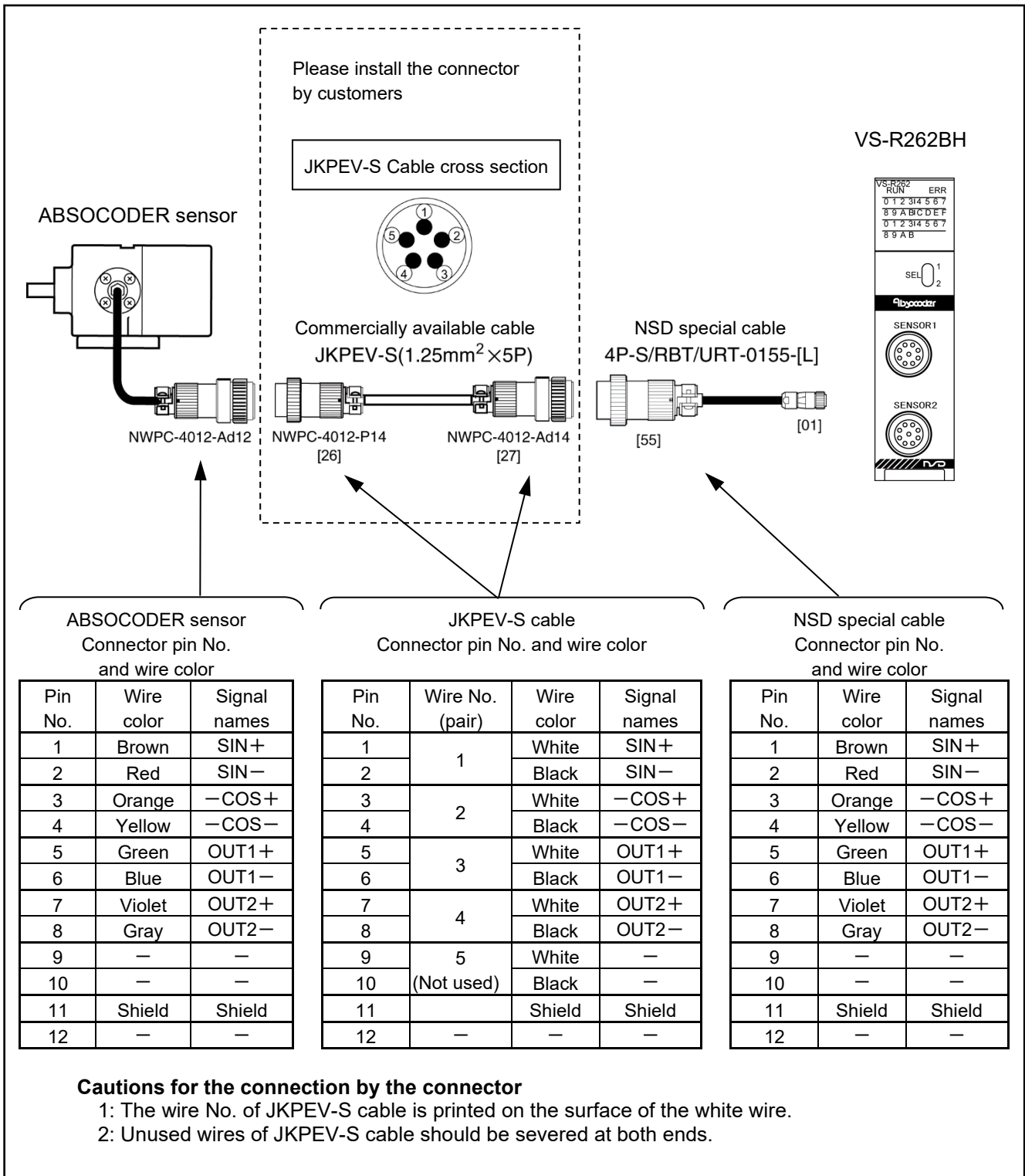

APPENDIX 3 DIMENSIONS

Appendix 3.1 VS-R262BH Position Detection Module

Units: mm

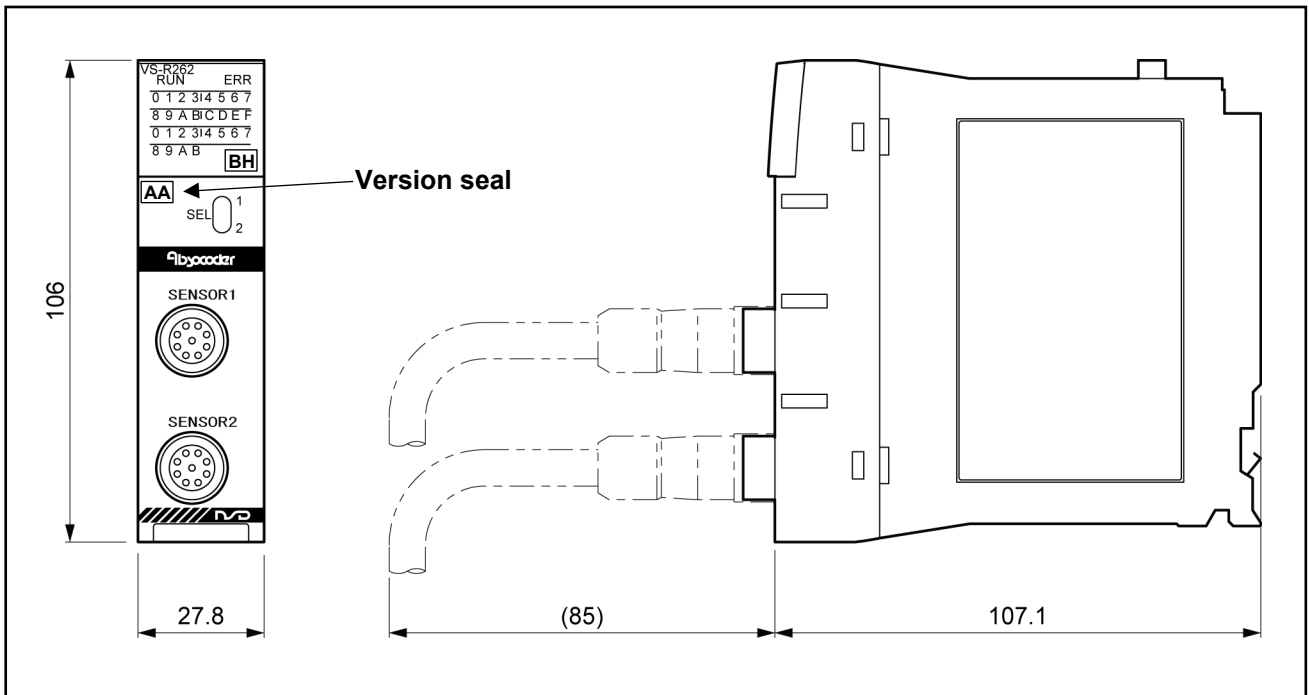

MEMO

APPENDIX 4 ABSOCODER SENSOR CHECK LIST

● **Applicable ABSOCODER sensor models**

MRE-32SP061, MRE-32SP074, MRE-32SP097, MRE-32SP101
 MRE-G[]SP061, MRE-G[]SP074, MRE-G[]SP097, MRE-G[]SP101

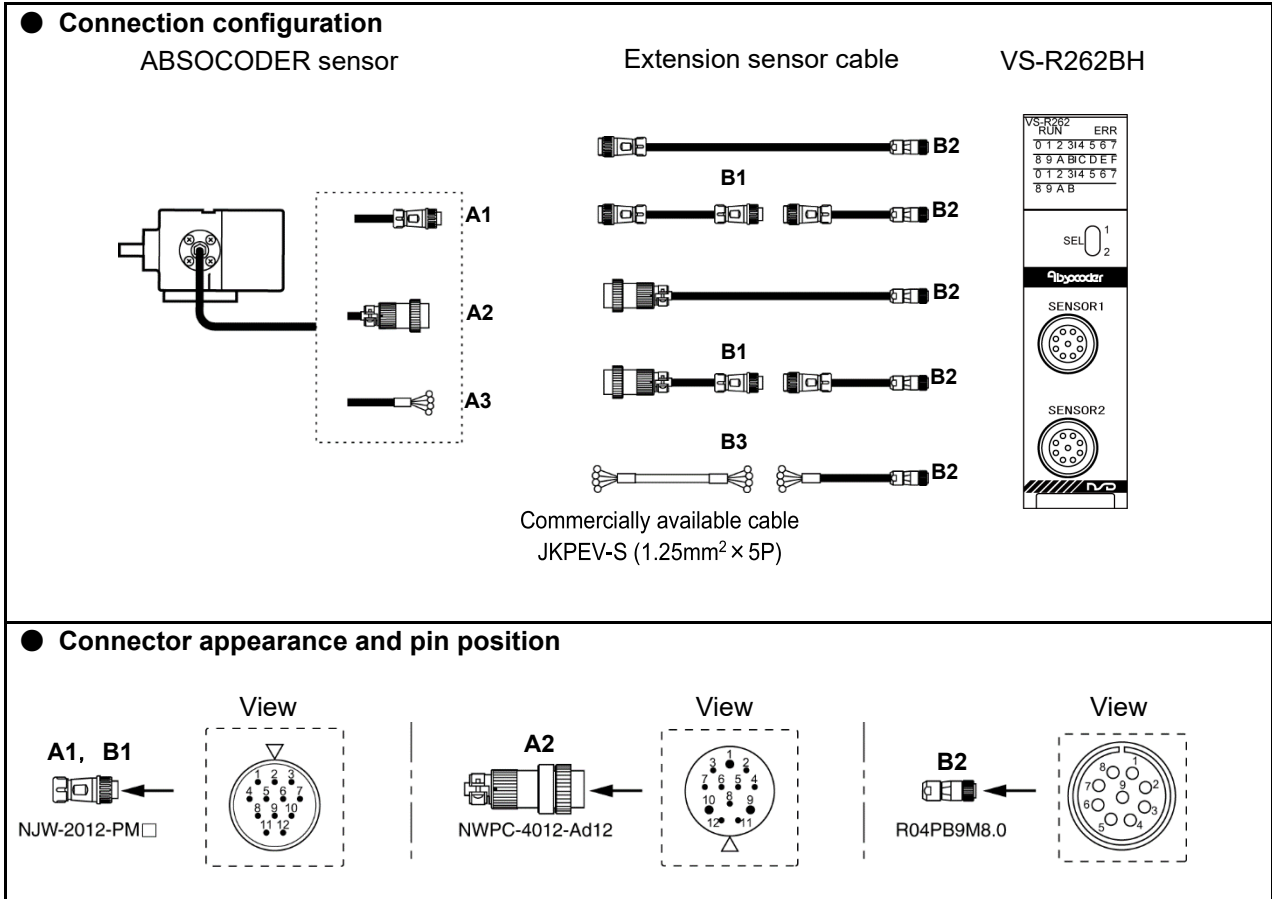

● **Connector appearance and pin position**

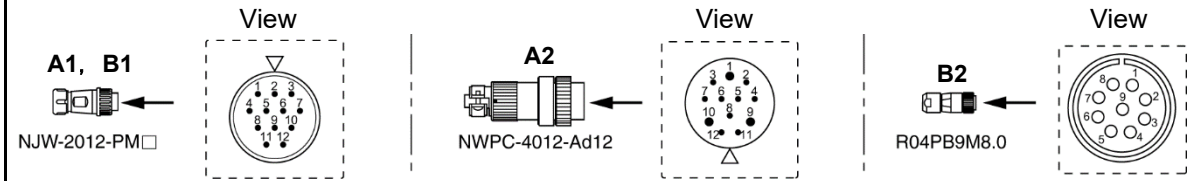

● **Connector pin position and standard coil resistance ranges (at 25°C)**

Check position						Signal names	Standard coil resistance [Ω]	
A1, A2, A3, B1		B2		B3			MRE-32SP061	MRE-32SP074, 097, 101 MRE-G[]SP061,074,097,101
Pin No.	Wiring color	Pin No.	Wiring color	Wire No. (pair)	Wiring color			
1	Brown	1	Brown	1	White	SIN+	92 to 102	82 to 90
2	Red	2	Red		Black	SIN-		
3	Orange	3	Orange	2	White	-COS+	92 to 102	82 to 90
4	Yellow	4	Yellow		Black	-COS-		
5	Green	5	Green	3	White	OUT1+	10 to 20	15 to 27
6	Blue	6	Blue		Black	OUT1-		
7	Violet	7	Violet	4	White	OUT2+	15 to 25	15 to 27
8	Gray	8	Gray		Black	OUT2-		
9	-	-	-	5	White	-		
10	-	-	-		Black	-		
11	Shield	9	Shield	-	Shield	Shield		
12	-	-	-	-	-	-		

The above standard coil resistance ranges are referential data to assist wiring disconnection diagnosis and are not product specification values. There may be no wiring disconnection even when the resistance measurement is out of the standard resistance range.

● **Circuit resistance check**

[Measurement method]

Measure the resistance at Point A or B by using a circuit tester or other appropriate device.
 Have Point A connected to measure at Point B.
 If the connector is off, identify the line by the wiring color.

[Check details]

Refer to the previous page for the connector pin number.

Check position	Criterion	Check position	Criterion
Between brown and red	The measured value should be in the range of the standard coil resistance. *1	Between brown and orange, green, violet, shield	∞
Between orange and yellow		Between orange and green, violet, shield	
Between green and blue		Between green and violet, shield	
Between violet and gray		Between violet and shield	
		Between frame and each wire or shield	

*1: If checks are done at Point B, the measurement value is [Standard coil resistance + extension sensor cable resistance].

Extension sensor cable resistance value

The resistance value of the NSD special cable is 0.2Ω/m (loop resistance).

The resistance value of the JKPEV-S cable is 0.034Ω/m (loop resistance).

Consider resistance variations due to temperature, which, relative to the standard temperature (25°C), increases 0.4% when the temperature rises 1°C and decreases 0.4% when the temperature falls 1°C.

● **Insulation check**

[Measurement method]

Measure the insulation resistance by using a 500 VDC insulation tester.

[Check details]

Refer to the previous page for the connector pin number.

Check position	Criterion
Between brown and orange, green, violet, shield	10MΩ or more
Between orange and green, violet, shield	
Between green and violet, shield	
Between violet and shield	
Between frame and each wire or shield	

 **NOTES**

1. Make sure to disconnect the ABSOCODER sensor from the VS-R262BH before carrying out insulation checks.
2. If there is a risk that energization may cause damages to the electronic circuits in and around the machine, remove the ABSOCODER sensor from the machine.
3. After completing the checks, short-circuit between the pins to discharge remaining voltage before connecting the ABSOCODER sensor to the VS-R262BH.

APPENDIX 5 I/O SIGNALS and BUFFER MEMORY FUNCTION LIST for VS-R262BH

○: enabled
 ×: disabled

Signal type	VS-R262BH (online/offline)		Online	Offline	Remarks
	Device No., address, and name				
Signal inputs to PLC CPU	X0	Unit ready (VS-R262BH detection)	○	○	
	X1	VS-R262BH operation status (online/offline)	ON	OFF	
	X2	Response for checking unit normality	○	○	This signal is added with version seal *C or later.
	X4	Axis-1 sensor error detection	○	○	
	X5	Axis-1 error detection	○	○	
	X8	Axis-2 sensor error detection	○	○	
	X9	Axis-2 error detection	○	○	
Signal outputs from PLC CPU	Y10	PLC ready	ON	OFF	
	Y12	Request for checking unit normality	○	○	This signal is added with version seal *C or later.
	Y13	Axis-1 current position setting command	○	×	Detected at leading edge
	Y16	Axis-2 current position setting command	○	×	Detected at leading edge
	Y1C	Error reset	○	○	Detected at leading edge
Buffer memory address	0, 1	Axis-1 sensor value (raw sensor binary value)	○	○	
	2, 3	Axis-1 current position value in CW direction (sensor binary)	○	○	
	4, 5	Axis-1 current position value in CCW direction (sensor binary)	○	○	
	6	Axis-1 input status	○	○	
	7	Axis-1 error code	○	○	
	690, 691	Axis-1 current position setting value	○	○	
	694	Axis-1 current position setting "disabled"	○	○	
	702	Axis-1 enabled/disabled	○	○	
	800	Inter-module synchronization state	○	○	
	802, 803	Axis-1 synchronization sensor value (raw sensor binary value)	○	○	
	804, 805	Axis-1 synchronization current position value in CW direction (sensor binary)	○	○	
	806, 807	Axis-1 synchronization current position value in CCW direction (sensor binary)	○	○	
	1000, 1001	Axis-2 Sensor value (Raw sensor binary value)	○	○	
	1002, 1003	Axis-2 current position value in CW direction (sensor binary)	○	○	
	1004, 1005	Axis-2 current position value in CCW direction (sensor binary)	○	○	
	1006	Axis-2 input status	○	○	
	1007	Axis-2 error code	○	○	
	1690, 1691	Axis-2 current position setting value	○	○	
	1694	Axis-2 current position setting "disabled"	○	○	
	1702	Axis-2 enabled/disabled	○	○	
	1800	Inter-module synchronization state	○	○	
	1802, 803	Axis-2 synchronization sensor value (raw sensor binary value)	○	○	
	1804, 1805	Axis-2 synchronization current position value in CW direction (sensor binary)	○	○	
	1806, 1807	Axis-2 synchronization current position value in CCW direction (sensor binary)	○	○	

APPENDIX 6 EVENT CODE LISTS for VS-R262BH

Event type	Category	Event item	Event code	Details
System	Error	Minor error	H01812	Axis-1 'buffer memory writing prohibited' error
			H01816	Axis-1 sensor error
			H01845	Axis-1 data error
			H01875	Axis-1 'buffer memory data writing' error
			H01C12	Axis-2 'buffer memory writing prohibited' error
			H01C16	Axis-2 sensor error
			H01C45	Axis-2 data error
			H01C75	Axis-2 'buffer memory data writing' error
		Moderate error	H02610	Inter-module synchronization signal error
Operation	Information	—	H24001	Online
			H24002	Offline
			H24100	Error reset
			H24110	Axis-1 current position setting value
			H24111	Axis-1 current position setting "disabled"
			H24112	Axis-1 current position setting "enabled"
			H24113	Axis-1 disabled
			H24114	Axis-1 enabled
			H26110	Axis-2 current position setting value
			H26111	Axis-2 current position setting "disabled"
			H26112	Axis-2 current position setting "enabled"
			H26113	Axis-2 disabled
			H26114	Axis-2 enabled



NSD Group

Manufacturer

NSD Corporation 3-31-28, OSU, NAKA-KU, NAGOYA, JAPAN 460-8302

Distributor

NSD Trading Corporation 3-31-23, OSU, NAKA-KU, NAGOYA, JAPAN 460-8302

Phone: +81-52-261-2352 Facsimile: +81-52-252-0522

URL: www.nsdcorp.com E-mail: foreign@nsdcorp.com

Copyright©2022 NSD Corporation All rights reserved.