



ZEF006082005

# **MELSEC-Q PLC Module Converter**

## **VS-QA62-M2PG**

### **User's Manual**

**Applicable sensor**

MRE-32SP062

MRE-G[ ]SP062





## ● SAFETY PRECAUTIONS ●

(Please read these precautions before operation.)

Before using this product, please read this manual and the relevant manuals carefully and pay full attention to safety to handle the product correctly.

The precautions given in this manual are concerned with this product only. For the safety precautions of the programmable controller system, refer to the CPU module user's manual.

In this manual, the safety precautions are classified into two levels: "  WARNING" and "  CAUTION".



### WARNING

Procedures which may lead to a dangerous condition and cause death or serious injury if not carried out properly.



### CAUTION

Procedures which may lead to a dangerous condition and cause superficial to medium injury, or physical damage only, if not carried out properly.

Depending on circumstances, procedures indicated by "  CAUTION" may also be linked to serious results.

Store this manual in a safe place so that you can take it out and read it whenever necessary. Always forward it to the end user.

### [ Application Limitation ]

This product is not designed to be used under any situation affecting human life. When you are considering using this product for special purposes such as medical equipment, aerospace equipment, nuclear power control systems, traffic systems, and etc., please consult with NSD.

This product is designed to be used under the industrial environments categorized in Class A device.

The supplier and user may be required to take appropriate measures.

### [ Design Precautions ]



## WARNING

- Provide an external safety circuit so that the entire system functions safely even when the external power supply or the CPU module is faulty.

Failure to do so may lead to incorrect output or malfunction, resulting in an accident.

- (1) Provide an external circuit of PLC emergency stop circuit and an interlock circuit to prevent the machine from being damaged (e.g. position detection upper and lower limits).
- (2) When this module detects an error, all output signals may turn OFF depending on the type of the error. Provide an external fail safe circuit.
- (3) Output may remain ON or OFF depending on failure of external output devices, such as a transistor. Provide a circuit that can be monitored externally for output signals that may result in serious accidents.



## CAUTION

- Do not bind or close the control cable and the communication cable with the main circuit cable and the power cable. Keep the former cables at least 300 mm or more away from the latter cables. Failure to do so may result in malfunction due to noise.

## [ Installation Precautions ]

### **WARNING**

- Be sure to shut off all power before mounting/removing this module.  
Failure to do this could result in equipment damage.

### **CAUTION**

- Use the programmable controller in an environment that meets the general specifications contained in the CPU User's Manual.  
Failure to do so may result in electrical shock, fire, malfunction, product damage, or deterioration of performance.
- While pressing the installation lever located at the bottom of module, insert the module fixing tab into the fixing hole in the base unit until it stops. Then, securely mount the module with the fixing hole as a supporting point. Improper loading of the module can cause a malfunction, failure or drop.  
For use in vibratory environment, tighten the module with screws.  
Tighten the screws within the specified torque range.  
Undertightening can cause a drop, short circuit or malfunction.  
Overtightening can cause a drop, short circuit or malfunction due to damage to the screws or module.
- Never directly touch this module's conductive areas or electrical components, because this can cause this module to malfunction or failure.
- Verify that the external input/output connectors and the sensor connectors are securely connected to the unit.  
Poor connections may result in poor contact, causing incorrect inputs and outputs.

## [ Wiring Precautions ]

### **WARNING**

- Shut off the external power supply (all phases) used in the system before installation and wiring.  
Failure to do so may result in electric shock or cause the module to fail or malfunction.

### **CAUTION**

- Prevent foreign matter such as dust or wire chips from entering the module. Such foreign matter can cause a fire, failure, or malfunction.
- A protective film is attached to the top of the module to prevent foreign matter, such as wire chips, from entering the module during wiring. Do not remove the film during wiring. Remove it for heat dissipation before system operation.

### [ Start-up and Maintenance Precautions ]

#### **WARNING**

- Be sure to shut off all power before cleaning this module or tightening screws.  
Failure to do so may result in failure or malfunction of this module.  
Loose screws can cause drops of the screws, short circuit or malfunction.  
Over-tightening screws may damage the screws and/or the module, this can cause drops, short circuit or malfunction.

#### **CAUTION**

- Do not disassemble, or modify this module.  
Failure to do so may result in failure, malfunction, injury, or fire.
- Shut off the external power supply (all phases) used in the system before installation and wiring.  
Failure to do this could result in failure or malfunction of this module.
- Do not mount/remove the module to/from the base unit more than 50 times after the first use of the product. (IEC 61131-2 compliant)  
Failure to do so may cause malfunction.
- Before starting test operation, set the parameter speed limit value to the slowest value, and make sure that operation can be stopped immediately if a hazardous state occurs.
- Always make sure to touch a grounded metal to discharge the static electricity from your body, etc., before touching the module.  
Failure to do so may cause a failure or malfunctions of this module.

### [ Disposal Precautions ]

#### **CAUTION**

- Be sure to handle this module as industrial waste when disposing of it.



# INTRODUCTION

Thank you for purchasing the VS-QA62 module.

Always read through this manual, and fully comprehend the functions and performance of VS-QA62 before starting use to ensure correct usage of this product.

Please submit this manual to the end user.

## CONTENTS

SAFETY PRECAUTIONS .....	i
REVISION HISTORY .....	iv
INTRODUCTION .....	v
CONTENTS .....	v
HOW TO READ THIS MANUAL .....	ix
TRADEMARK .....	ix
<b>1. OVERVIEW .....</b>	<b>1</b>
1.1 Features .....	2
1.2 Definitions .....	4
1.2.1 Definition related to the current position detection .....	4
1.2.2 Definition related to the limit switch output .....	5
1.2.3 Definition related to positioning .....	5
<b>2. SYSTEM CONFIGURATION .....</b>	<b>7</b>
2.1 Overall Configuration .....	7
2.2 Applicable System .....	8
<b>3. VS-QA62 SPECIFICATIONS .....</b>	<b>9</b>
3.1 General Specifications .....	9
3.2 Performance Specifications .....	10
3.3 Function Block Diagram .....	11
3.4 External Input/Output Interface Specifications .....	12
3.4.1 Input/output specifications .....	12
3.4.2 Input/output connector pin arrangement .....	13
3.5 List of functions .....	17
3.6 Specifications of Input/Output Signal with Programmable Controller CPU .....	19
3.6.1 List of input/output signals with programmable controller CPU .....	19
3.6.2 Details of input signal (VS-QA62 → Programmable controller CPU) .....	20
3.6.3 Details of output signals (Programmable controller CPU → VS-QA62) .....	22
3.7 Buffer Memory List .....	25
<b>4. HANDLING AND WIRING .....</b>	<b>29</b>
4.1 VS-QA62 Handling Precautions .....	29
4.2 Wiring Precautions .....	29
4.3 Precautions for Installation of ABSOCODER Sensors .....	30
4.3.1 ABSOCODER sensor installation .....	30
4.3.2 Precautions for connecting ABSOCODER sensors .....	33

<b>5. SETUP AND PROCEDURES BEFORE OPERATION .....</b>	<b>35</b>
5.1 Name of Parts and Functions .....	35
5.2 Procedure Before the Operation .....	37
5.3 Procedures for the Initial and Parameter Settings.....	38
5.3.1 Procedures for the initial settings.....	39
5.3.2 Procedures for parameter settings.....	41
5.3.3 Procedures when setting initial and parameter simultaneously .....	42
5.3.4 Readout procedures for the initial and parameter settings .....	44
5.4 Setting Procedures for the Limit Switch Output Data.....	45
<b>6. CURRENT POSITION DETECTION FUNCTION .....</b>	<b>47</b>
6.1 Current Position Value .....	48
6.2 Initial Setting Function (Scaling).....	49
6.2.1 Initial setting list.....	49
6.2.2 Sensor shaft rotation direction (Address 702) .....	49
6.2.3 Scale length (Address 704 and 705).....	50
6.2.4 Minimum current position value (Address 706 and 707).....	51
6.2.5 Current position value (Address 708 and 709).....	52
6.3 Parameter for Related to the Current Position Detection .....	53
6.4 Pulse Output Function .....	55
6.4.1 Pulse number setting.....	55
6.4.2 Operation conditions.....	56
6.5 'Excessive Current Position Change' Detection Function .....	57
6.6 Current Position 'PRESET' Function .....	58
6.6.1 The current position preset function (Address 748) setting.....	59
6.6.2 The current position preset value setting.....	60
6.6.3 'Excessive correction amount' detection .....	61
6.6.4 Operation condition of the current position 'PRESET' function.....	62
6.6.5 Input status storage area (Address 6) .....	64
6.7 Current Position HOLD Function .....	65
6.8 Speed Detection Function.....	66
6.8.1 Parameter setting.....	66
6.8.2 Speed output storage area (Address 668 and 669).....	67
6.9 Analog Voltage Output Function (Position/Speed).....	69
6.9.1 Parameter setting.....	69
6.9.2 Setting example .....	71
<b>7. LIMIT SWITCH OUTPUT FUNCTION.....</b>	<b>73</b>
7.1 Setting Contents of the Limit Switch Output Data .....	74
7.1.1 Setting conditions of the ON and OFF zones.....	76
7.2 Parameter for Related to the Limit Switch Output .....	77
7.3 Output Signal Selection Function.....	78
7.4 Offline Channel Output Status Setting.....	79
7.5 Limit Switch Output Disabled Function.....	80
7.6 Limit Switch Output Selection when Positioning Function .....	81
7.7 Limit Switch Output Operation.....	82
7.7.1 Procedures before the operation.....	82
7.7.2 'Limit switch output status' storage area (Address 4).....	83
<b>8. POSITIONING FUNCTION (2-SPEED/3-SPEED CONTROL) .....</b>	<b>85</b>
8.1 Parameter for Related to the Positioning.....	86



8.2	Positioning Format and Simple Learning Function Selection .....	88
8.2.1	Speed switching format (2-speed control) .....	89
8.2.2	Speed stepping format (3-speed control).....	90
8.2.3	Simple learning function .....	91
8.3	Unidirectional Positioning .....	93
8.4	Positioning Pattern Data Setting.....	94
8.4.1	Setting of the positioning pattern data buffer memory selection .....	96
8.4.2	Parameter area settings.....	96
8.4.3	RAM area settings .....	97
8.4.4	Speed limitation .....	97
8.5	Upper / Lower Overtravel Detection Function .....	98
8.6	'START from Stop Zone' Function.....	99
8.7	Positioning Operation .....	101
8.7.1	Procedure for the positioning operation.....	101
8.7.2	Positioning target stop position setting.....	102
8.7.3	Controlling timing.....	103
8.7.4	Positioning output status area (Address 696).....	106
8.7.5	Current position preset during the positioning operation .....	107
8.8	JOG Operation .....	108
8.9	Operation Error.....	111
<b>9. POSITIONING (ACCELERATION/DECELERATION CONTROL) .....</b>		<b>113</b>
9.1	Parameter Related to the Acceleration/Deceleration Control .....	114
9.2	Positioning Format and Simple Learning Function Selection .....	116
9.2.1	Simple learning function .....	117
9.3	Unidirectional Positioning .....	119
9.4	In-position Zone.....	120
9.5	Upper / Lower Overtravel Detection Function .....	121
9.6	'START from Stop Zone' Function.....	122
9.7	Positioning Pattern Data Setting.....	124
9.7.1	Positioning pattern lists .....	124
9.7.2	Contents of pattern data for the operation.....	125
9.7.3	Contents of the pattern data for the STOP.....	131
9.7.4	Contents of the pattern data when overshooting .....	132
9.8	Analog Voltage Output Function (Speed Command).....	133
9.8.1	Parameter setting.....	133
9.8.2	Setting example .....	135
9.9	Positioning Operation .....	136
9.9.1	Procedure for the positioning operation.....	136
9.9.2	Positioning target stop position setting.....	137
9.9.3	Positioning output status area (Address 696).....	138
9.9.4	Speed command area .....	138
9.9.5	Current position preset during the positioning operation .....	139
9.10	JOG Operation .....	140
9.11	Operation Error.....	142
<b>10. TROUBLESHOOTING .....</b>		<b>145</b>
10.1	Error Code List .....	145
10.2	Troubleshooting Flowchart.....	151
10.3	Flowchart for No Limit Switch output from VS-QA62 .....	152
10.4	Flowchart for No Positioning Output from VS-QA62 .....	153
10.5	Flowchart when Current Position Preset is Impossible .....	154

10.6	Flowchart when Current Position Value doesn't Change.....	155
10.7	Flowchart when Stored Data is Lost, or when Erroneous Data is Stored.....	156
<b>APPENDIX 1 VS-QA62 AND CABLE OUTER DIMENSIONS .....</b>		<b>157</b>
Appendix 1.1	VS-QA62 .....	157
Appendix 1.2	External I/O Cable (VS-CQA62).....	158
Appendix 1.3	Cable for the Upgrading (VS-CQA62-R01).....	159
<b>APPENDIX 2 ABSOCODER SENSOR SPECIFICATIONS .....</b>		<b>161</b>
Appendix 2.1	Sensor Specifications.....	161
Appendix 2.2	Sensor Dimensions.....	162
<b>APPENDIX 3 ABSOCODER CABLE SPECIFICATIONS .....</b>		<b>164</b>
Appendix 3.1	Cable Specifications.....	164
Appendix 3.2	Cable Length Restrictions.....	164
Appendix 3.3	Cable Dimensions .....	164
Appendix 3.4	Connection Example of the ABSOCODER Cable .....	165
<b>APPENDIX 4 CE MARKING .....</b>		<b>166</b>
<b>APPENDIX 5 UL STANDARD .....</b>		<b>167</b>
<b>APPENDIX 6 KC MARK.....</b>		<b>168</b>
<b>APPENDIX 7 ABSOCODER SENSOR CHECK LIST .....</b>		<b>169</b>
<b>APPENDIX 8 SAMPLE PROGRAM.....</b>		<b>171</b>
Appendix 8.1	Program Creation Precautions .....	171
Appendix 8.2	Program for Writing Initial Settings and Parameter Settings .....	172
Appendix 8.3	Program for Current Position Monitor Display.....	177
Appendix 8.4	Program for Error Code Readout and Reset .....	178
Appendix 8.5	Program for Limit Switch Output Function.....	179
Appendix 8.6	Readout Program of the Limit Switch Output Status.....	181
Appendix 8.7	Program for Positioning Function .....	182
Appendix 8.8	Program for JOG operation.....	185
<b>APPENDIX 9 I/O SIGNALS AND BUFFER MEMORY FUNCTION LIST .....</b>		<b>186</b>
<b>APPENDIX 10 DATA SHEET .....</b>		<b>190</b>
Appendix 10.1	Initial Setting and Parameter Setting Sheet.....	190
Appendix 10.1.1	Initial setting.....	190
Appendix 10.1.2	Parameter setting.....	191
Appendix 10.2	Limit Switch Data Sheet.....	192
Appendix 10.2.1	CH. 0 to CH. 3 .....	192
Appendix 10.2.2	CH. 4 to CH. 7 .....	192
Appendix 10.2.3	CH. 8 to CH. 11.....	193
Appendix 10.2.4	CH. 12 to CH. 15.....	193

## HOW TO READ THIS MANUAL

This manual describes the product names as the following;

(1) Module Name

VS-QA62-M2PG (hereafter call"VS-QA62")

(2) ABSOCODER SENSOR

In this manual, the ABSOCODER Sensor is described as the following;

ABSOCODER Sensor

Sensor

## TRADEMARK

MELSEC is the trademark or registered trademark of Mitsubishi Electric Corporation.

Other companies' and products' names are the trademark or registered trademark of each company.

## 1. OVERVIEW

This user's manual contains the specifications and operation/programming procedures for VS-QA62 which is to be used in combination with the MELSEC-Q Series manufactured by Mitsubishi Electric Corporation.

VS-QA62 is a module that can detect positions by combining with the ABSOCODER sensor.

The ABSOCODER sensor is a magnetic position sensor that can replace with incremental type encoders widely used until now.

Machine positions are detected easily by combining VS-QA62 and the ABSOCODER sensor.

VS-QA62 can be used to automatically control the position detection of the conveyor, press machine, assembly machine, packing machine, etc.

VS-QA62 also offers the following functions;

- Current position value detection
- Limit switch output
- Positioning (speed switching format, acceleration/deceleration control format)

## 1.1 Features

VS-QA62 has the following features:

### (1) Absolute position detection:

Rotational position is detected by an absolute position detection method.

Even when a power outage, etc., occurs, the correct position of the ABSOCODER sensor will be instantly detected when power is turned back ON.

### (2) High resolution:

The 32-turn type ABSOCODER sensor (the MRE Series) offers a resolution factor of 4096 divisions per 1 turn of the sensor shaft.

The resolution factor for a 64-turn type ABSOCODER sensor is half the amount given above.

Refer to APPENDIX 2 for details regarding the relationship between the number of turns and the resolution.

### (3) High-speed response

VS-QA62 is not affected by the PLC's scan time.

The position detection is executed every 0.2ms.

### (4) Current position preset function

If a positional discrepancy occurs between the machine's position and the ABSOCODER sensor's position, the current position can be preset to the desired value by external input or device Y.

### (5) Current position HOLD function

By the current position preset input (external connector) is turned ON (leading edge), the current position of that time is stored in the buffer memory.

### (6) Speed detection function:

The ABSOCODER sensor's rotation speed can be monitored.

The detected value (amount of change in current position value per specified time) is stored in the buffer memory as sensor binary value.

### (7) Unidirectional positioning format

Positioning toward the target stop position is always executed from a single direction.

This function can reduce positioning errors caused by a gear backlash.

### (8) Three types of the speed control format

The speed control format of the positioning function can be selected from the followings;

- Speed switching format (2-speed control)
- Speed stepping format (3-speed control)
- Acceleration/deceleration control format (The speed command that the machine's maximum speed was converted to 100% is output.)

### (9) Speed limit function

The operation speed can be limited when positioning.

### **(10) High accuracy positioning by the simple learning function**

When a positional discrepancy occurs between the target position and the stop position upon completion of positioning, the discrepancy will be automatically corrected for the next positioning.

### **(11) Pulse output function**

The A/B phase pulse is output to the external I/O connector without being affected by the PLC's scan time.

Positioning responsiveness can be improved by inputting the A/B phase pulse to the vector control inverter or other devices.

### **(12) Analog output function**

The speed, current position value, and "speed command for the positioning function" can be output in the analog voltage.

### **(13) Compliance with UL and CE standards:**

VS-QA62 complies with both UL (UL508) and CE (EMC Directive) standards.

### **(14) Compliance with KC mark (Korea Certification Mark)**

VS-QA62 complies with KC mark. (It is only certified under the Radio Waves Act of South Korea.)

KC mark is the same directives as CE marking.

## 1.2 Definitions

### 1.2.1 Definition related to the current position detection

Item	Contents
ABSOCODER	<p>ABSOCODER is the generic name given to the NSD-developed position sensor which detects rotational/linear displacement, speed, and acceleration, using an absolute position detection method with a digital (or analog) output.</p> <p>The ABSOCODER consists of two main components:            The sensor, where displacement is detected by the change in magnetic resistance, and the converter, where the sensor's output signal (when an AC excitation signal has been applied to the sensor) is converted into absolute data.</p> <p>The converter for the ABSOCODER sensor is built-in to VS-QA62.</p>
Current position detection function	<p>Positions used to be detected by a combination of the incremental type encoder and counter unit.</p> <p>This function detects them with a combination of the ABSOCODER sensor and VS-QA62.</p> <p>For more details, refer to "Chapter 6".</p>
Scale length	<p>This is the maximum distance over which the ABSOCODER sensor can perform absolute position detection.</p> <p>The scale length can be specified in a system-of-units that is appropriate to the machine's travel amount.</p> <p>With multi-turn type ABSOCODER sensors (MRE), the scale length is the amount of machine travel attained after the sensor shaft has completed a total number of turns (32, 64, 128, 160, 256, 320).</p> <p>For more details, refer to "Chapter 6.2.3".</p>
Minimum current position value	<p>This is the minimum value of the current position value which can be detected.</p> <p>This value can be designated as desired within the following range: <math>-99999</math> to <math>[1000000 - \text{scale length}]</math>.</p> <p>For more details, refer to "Chapter 6.2.4".</p>
Current position value	<p>This current position value indicates where the machine is currently positioned within the machine detection range.</p> <p>This can be expressed in two ways;</p> <ul style="list-style-type: none"> <li>● <b>Sensor binary value</b>              This value is counted inside of VS-QA62 when the ABSOCODER sensor shaft rotates.              It changed from 0 to 131071 (0 to 1FFFFH) when the shaft rotates from 0 to the total number of turns.              The total number of turns is decided based on the sensor model.              Ex: MRE-32SP062, the total number of turns is 32.</li> <li>● <b>Scaling binary value</b>              The value is converted into a unit such as mm or inch based on the sensor binary value by setting the scale length and minimum current position value.              This value indicates the machine's current position.</li> </ul> <p>For more details, refer to "Chapter 6.1".</p>
Current position preset function	<p>Set the preset value to a parameter in advance.</p> <p>The current position value of the buffer memory (scaling binary) is corrected to the preset value by turning ON either signals online.</p> <ul style="list-style-type: none"> <li>- "Current position preset command" of the device Y</li> <li>- "Current position preset input" of the I/O connector</li> </ul> <p>For more details, refer to "Chapter 6.6".</p>

## 1.2.2 Definition related to the limit switch output

Items	Contents
Limit switch output function	<p>The limit switch output works in the same way as outputs from a mechanical limit switch.</p> <p>The positions that mechanical limit switches turn ON or OFF are designated to the VS-QA62 in advance. VS-QA62 turns ON or OFF the limit switch output signal by comparing the machine position detected by the ABSOCODER sensor and setting value.</p> <p>The output point is a maximum of 16-point (0 to 15 channels).</p>
Dog	The combination of ON and OFF positions of the limit switch output is called "dog".
Multi-dog	<p>The limit switch output switch output can set up to five ON and OFF positions (Dogs) for each channel. This is called "multi-dog".</p>

## 1.2.3 Definition related to positioning

Items	Contents
Positioning function	The positioning function is that stops the machine to the designated position.
Speed switching control	<p>Switch the speed to stop the machine at the target stop position (target value).</p> <p>The control formats are a speed switching format (2-speed) and speed stepping format (3-speed) .</p>
Acceleration/Deceleration control	<p>The speed command that the machine's maximum speed was converted to 100% is output.</p> <p>The speed outputs each 1%, so the machine can be smoothly accelerated or decelerated the speed.</p>
Unidirectional positioning	<p>Positioning toward the target stop position is always executed from a single direction.</p> <p>When positioning is required in the opposite direction, the target stop position will be overshoot, and positioning will then occur from the prescribed direction (U-turn is made).</p> <p>The unidirectional positioning format is useful in reducing stop position errors caused by backlash.</p>
Starting from stop zone	This function can start a positioning operation from inside the stop zone.
In-position zone	<p>This is a reference distance used to determine if the machine is stopped at the target stop position, and is a distance from the target value.</p> <p>When the stop position is within the in-position zone, the in-position signal output will occur.</p>
Overshoot amount	This is a distance by which the target stop position is overshoot before a U-turn is made when executing the "unidirectional positioning" or "start from stop zone".
Stop zone	This is the distance between the target stop position (target value) and the position where the brake applied.
Brake release	This is the output signal which releases the motor's brake.
FWD/RVS	The current position value increases in the FWD (forward) direction and decreases in the RVS (reverse) direction.
Simple Learning Function	When a positional discrepancy occurs between the target position and the current position upon completion of positioning, the discrepancy will be automatically corrected for the next positioning.
JOG operation	The machine travels to the designated direction during JOG signal of FWD or RVS is ON.





## 2. SYSTEM CONFIGURATION

### 2.1 Overall Configuration

The overall configuration of the Mitsubishi Electric corp. MELSEC-Q Series using VS-QA62 is shown below.

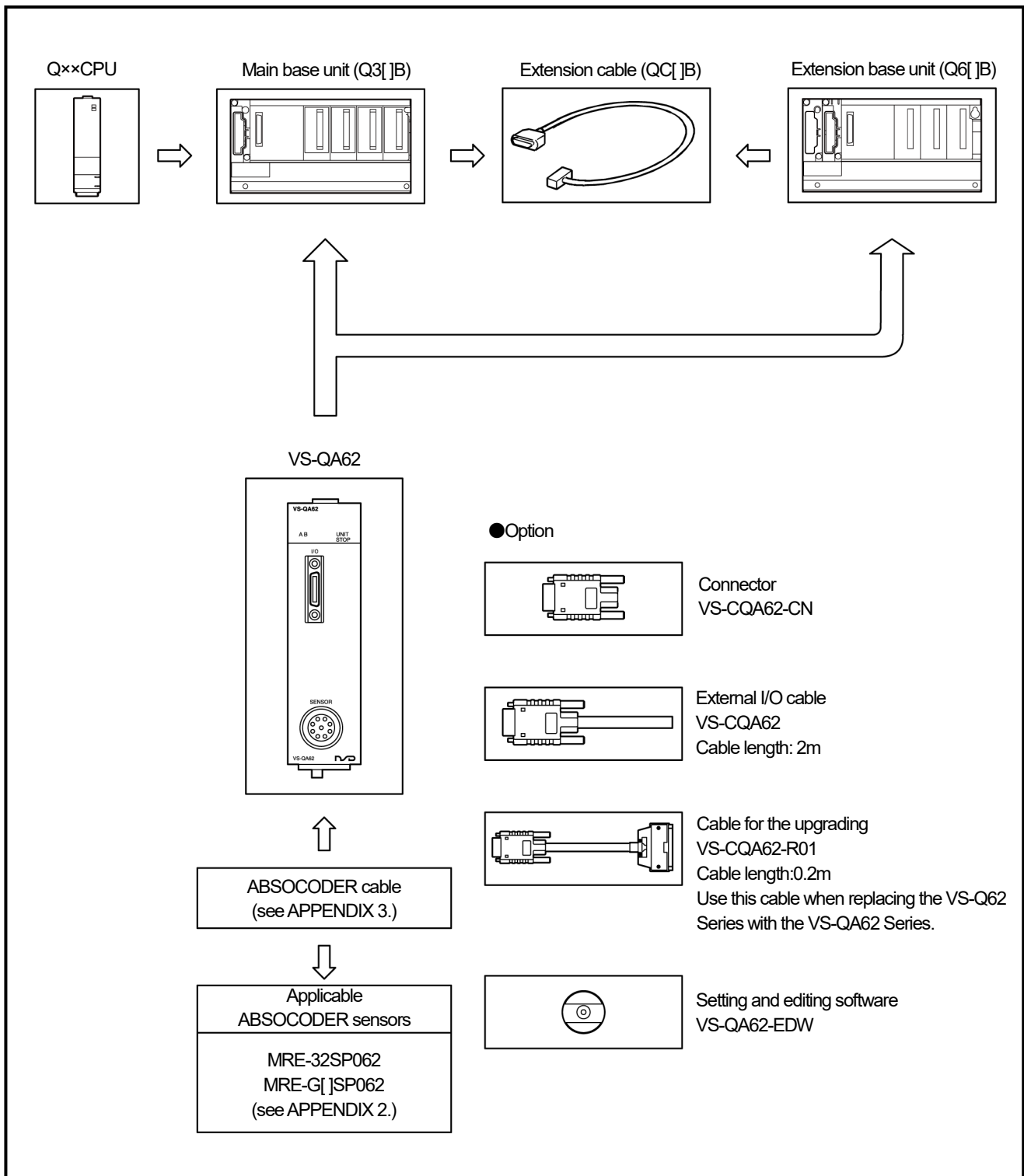

### 2.2 Applicable System

VS-QA62 can be used in the following system.

**(1) Applicable CPU module**

Refer to NSD web site for CPU module models with which VS-QA62 can be used.

**(2) Number of mountable modules**

Pay attention to the power supply capacity before mounting modules.

Change the combination of the modules if the power supply capacity is insufficient.

**(3) Applicable base units**

VS-QA62 can be installed to any I/O slot of a base unit.

### 3. VS-QA62 SPECIFICATIONS

Shown below are the VS-QA62 specifications.

About the ABSOCODER sensor specifications, refer to "APPENDIX 2".

#### 3.1 General Specifications

Items	Specifications					
Operating ambient temperature	0 to 55°C					
Storage ambient temperature	-25 to 75°C <sup>*3</sup>					
Operating ambient humidity	5 to 95%RH <sup>*4</sup> , non-condensing					
Storage ambient humidity						
Vibration resistance	Compliant with JIS B 3502 and IEC 61131-2		Frequency	Constant acceleration	Half amplitude	Sweep count
		Under intermittent vibration	5 to 8.4Hz	—	3.5mm	10 times each in X, Y, Z directions
			8.4 to 150Hz	9.8m/s <sup>2</sup>	—	
		Under continuous vibration	5 to 8.4Hz	—	1.75mm	—
8.4 to 150Hz	4.9m/s <sup>2</sup>		—	—		
Shock resistance	Compliant with JIS B 3502 and IEC 61131-2 (147 m/s <sup>2</sup> , 3 times each in 3 directions X, Y, Z)					
Operating atmosphere	No corrosive gases					
Operating altitude <sup>*5</sup>	0 to 2000m					
Installation location	Inside a control panel					
Over voltage category <sup>*1</sup>	II or less					
Pollution degree <sup>*2</sup>	2 or less					
Equipment class	Class I					

\*1: This indicates the section of the power supply to which the equipment is assumed to be connected between the public electrical power distribution network and the machinery within premises.

Category II applies to equipment for which electrical power is supplied from fixed facilities. The surge voltage withstand level for up to the rated voltage of 300V is 2500V.

\*2: This index indicates the degree to which conductive material is generated in terms of the environment in which the equipment is used.

Pollution level 2 is when only non-conductive pollution occurs. A temporary conductivity caused by condensing must be expected occasionally.

\*3: The storage ambient temperature is -20 to 75°C if the system includes the AnS/A series modules.

\*4: The operating ambient humidity and storage ambient humidity are 10 to 90%RH if the system includes the AnS/A series modules.

\*5: Do not use or store the programmable controller under pressure higher than the atmospheric pressure of altitude 0m. Doing so may cause malfunction.

### 3. VS-QA62 SPECIFICATIONS

#### 3.2 Performance Specifications

1/2

Items		Specifications			Remarks
Number of position detection axes		1			
Position detection method		Absolute position detection by ABSOCODER sensors			
Number of divisions (Resolution)		131072 divisions ([4096 divisions×32 turns] to [409.6 divisions×320 turns])			Refer to "APPENDIX 2" for details.
Limit switch output function	Number of programs	1			Data is not held when power is OFF.
	Number of multi-dogs	5-dog/CH.			
	Number of output channels	Function selection	For limit switch output function only	For positioning function	*1: Selected by parameter setting "In-position" → CH.5 "Positioning in progress" → CH.6 "Operation error" → CH.7 Total: 3ch selection
		I/O output	8 CH.	0 CH. *1	
		Device X	8 CH.	0 CH.	
Buffer memory		16 CH.	16 CH.		
Positioning function (speed switching control)	Control format	Unidirectional positioning			Bidirectional positioning when 'overshoot amount' is set to '0'
	Target position setting method	1-point setting prior to positioning operation by the sequence program			
	Max. number of positioning points	1-point			
	Number of registered positioning pattern data	2			Select either Parameter area (a 700 number of the address) or RAM area (a 600 number of the address).
	Number of channels for positioning signal output	8-point FWD, RVS, High-speed, Low-speed, Brake release, In-position, Positioning in progress, Operation error			In-position, Positioning in progress, and Operation error can be switch to the limit switch output by the parameter.
Positioning function (acceleration/deceleration control)	Control format	Unidirectional positioning			Bidirectional positioning when 'overshoot amount' is set to '0'
	Target position setting method	1-point setting prior to positioning operation by the sequence program			
	Max. number of positioning points	1-point			
	Number of channels for positioning signal output	7-point FWD, RVS, Brake release, In-position, Positioning in progress, Operation error, Speed command			In-position, Positioning in progress, and Operation error can be switch to the limit switch output by the parameter.
	Number of registered positioning pattern data	1			
Current position setting function		Initial setting, Current position preset			
JOG operation function		JOG operation executed by FWD JOG/RVS JOG signal inputs			
Pulse output count		1 to 131072pulse			Output pulse number in the all detection range

Items		Specifications	Remarks
Updating cycle (Response time)	Limit switch output signal & positioning output signal	0.4ms (0.8ms)	Max. response delay time due to internal processing
	Current position value output	0.2ms (0.4ms)	
Gate time	Speed output	Able to select by parameter setting 0.8ms, 1.6ms, 3.2ms, 6.4ms, 12.8ms, 25.6ms, 51.2ms	
	Rotation speed output	234.4ms	
	Travel speed output	1000ms	
No. of occupied I/O points		32 points (I/O assignment: Intelligent function module 32 points)	
Internal current consumption (DC5V)		0.70A	
Outline dimensions		98mm (h) × 27.4mm (w) × 90mm (d)	
Mass		0.2kg	
Module name on the display at the PLC		008 VS-QA62-M2PG	
Applicable standard		UL508 CSA C22.2 No.142 (Compliance with c-RU standard) CE Marking (EMC Directive) KC mark (Korea Certification Mark)	

### 3.3 Function Block Diagram

Shows the block diagram of the VS-QA62 functions.

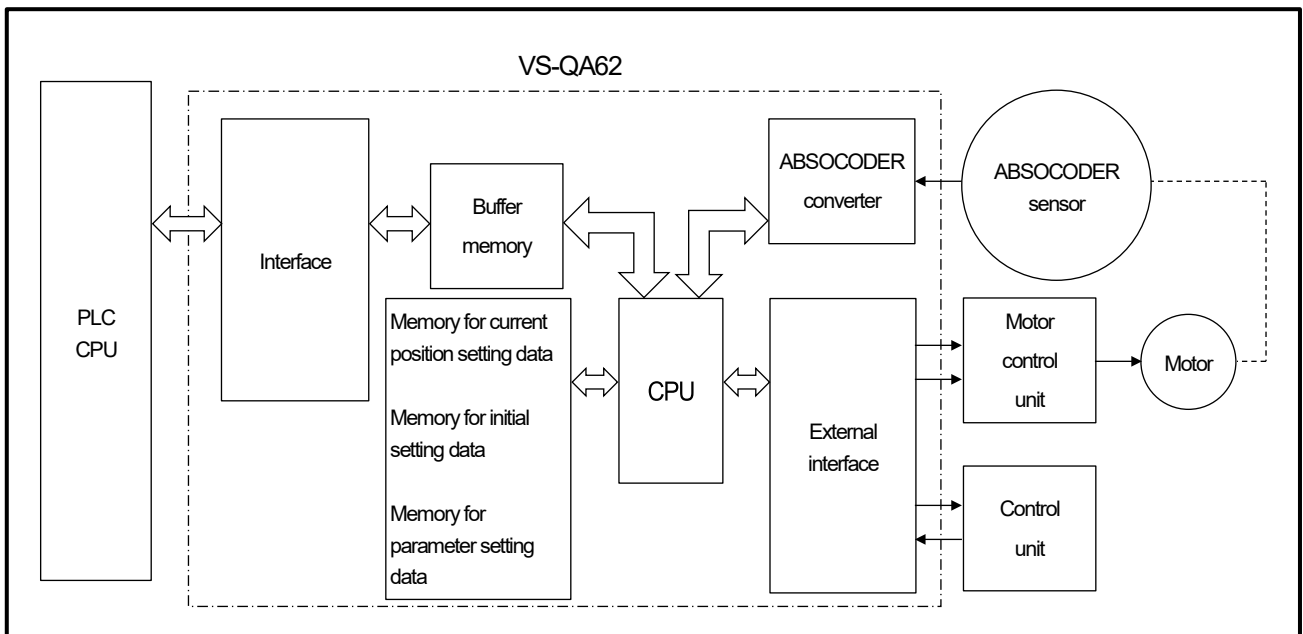

#### 3.4 External Input/Output Interface Specifications

##### 3.4.1 Input/output specifications

Items		Specifications	
Input circuit	Number of input points	Current position preset input: 2-point	
	Isolation method	Photo-coupler	
	Rated input voltage	DC12V	
	Rated input current	3mA	
	Input voltage range	10.2 to 30.0VDC	
	ON voltage	10 VDC or more	
	OFF voltage	2 VDC or less	
	Response time	OFF→ON	0.04ms (with input voltage of 24VDC)
		ON→OFF	0.5ms (with input voltage of 24VDC)
Common connections		1 common for 2points (common terminal: 11, 12)	
Output circuit	Number of output points	For current position detection function	No output
		For limit switch output function	Limit switch output: 8-point
		For Positioning function	Limit switch output: 0-point Positioning signal output: 8-point
	Isolation method		Photo-coupler
	Rated load voltage		12/24 VDC
	Load voltage range		10.2 to 30.0 VDC
	Max. load current		50mA
	Max. rush current		0.4A (10ms or less)
	Current leakage when OFF		0.1 mA or less
	Max. voltage drop when ON		2.0V or less at 50mA, 1.7V or less at 10mA
	Response time	OFF→ON	1ms (at 50mA, resistance load)
		ON→OFF	1ms (at 50mA, resistance load)
	Common connections		1 common for 8 points (common terminal: 24, 25)
Pulse output circuit	Signal name		A+/A-, B+/B-
	Output circuit		Line driver output (Equivalent to AM26C31C)
	Max. load current		±20 mA max./1 point
	Differential output voltage		2.0V or more (I <sub>o</sub> =20mA)
	Isolation method		Photo-coupler
	Min. load resistance		100Ω min.
	Power supply method		5VDC supplied from external source
	Voltage supply range		4.75 to 5.25VDC
	External power supply capacity		0.2A
Max. frequency		100kHz	
Analog output circuit	Signal name		Analog+ / Analog--
	Isolation method		Photo-coupler
	Output voltage range		-10V to +10VDC
	Output voltage resolution		0.3051 mV (-10V to +10V / 65536 divisions)
	Updating cycle		0.4ms
External cable connection format		26 pins connector	
Compatible wire size		AWG28 max.	

#### 3.4.2 Input/output connector pin arrangement

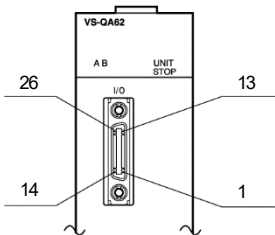
External connections *3						
Pin arrangement	Pin No.	For current position detection	Signal name			
			For limit switch output	For positioning		
				Speed switching format	Speed stepping format	Acceleration /Deceleration format
<p>When viewed from the front of the module</p> 	1	Not used *1	CH. 0	FWD	FWD/low-speed	FWD
	2	Not used *1	CH. 1	RVS	RVS/low-speed	RVS
	3	Not used *1	CH. 2	High-speed	High-speed	Not used
	4	Not used *1	CH. 3	Low-speed	Medium-speed	Not used
	5	Not used *1	CH. 4	Brake release		
	6	Not used *1	CH. 5	In-position [CH.5] *2		
	7	Not used *1	CH. 6	Positioning in progress [CH.6] *2		
	8	Not used *1	CH. 7	Operation error [CH.7] *2		
	9	Current position preset input 1				
	10	Current position preset input 2				
	11	Control input common				
	12	Control input common				
	13	Analog+				
	14	SG (pulse output)				
	15	5V (pulse output)				
	16	Not used				
	17	Not used				
	18	B- (pulse output)				
	19	B+ (pulse output)				
	20	A- (pulse output)				
	21	A+ (pulse output)				
	22	Not used				
	23	Not used				
	24	Control output common				
	25	Control output common				
	26	Analog-				



\*1: Nothing is output when the current position detection function is used.

\*2: A limit switch can be selected by "Limit switch output selection at positioning (Address 12)" of the buffer memory.

\*3: Select any one of the options when using the external I/O cable.

#### (1) Soldering-type connector

Model code: VS-CQA62-CN

Manufacturer: HONDA TSUSHIN KOGYO CO., LTD.

Model code of manufacturer: HDR-E26MSG1+ (connector), HDR-E26LPMP+ (cover)

The connector must be soldered by the customers.

For the assembly method, ask "HONDA TSUSHIN KOGYO CO., LTD."

##### ● Contents

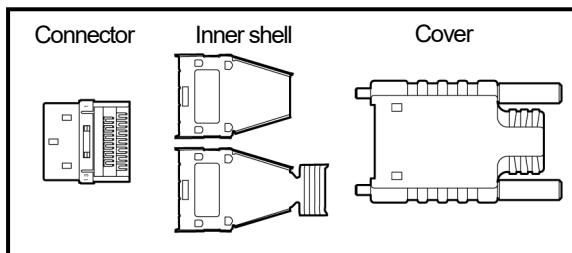

##### ● Pin No. at the terminal side which must be soldered

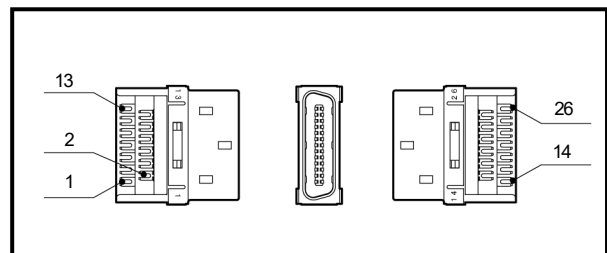

#### (2) Cable with a connector (One side of the cable end has a connector)

Model code: VS-CQA62 (Cable length: 2m)

Process the cable terminal according to the customers' devices.

For more details of the cable, refer to "Appendix 1.2".

#### (3) Cable for the upgrading (Both cable ends have connectors)

Model code: VS-CQA62-R01 (Cable length: 0.2m)

Use the cable when replacing the VS-Q62 Series with the VS-QA62 Series.

For more details of the cable, refer to "Appendix 1.3".

(1) Input circuit (Current position preset input)

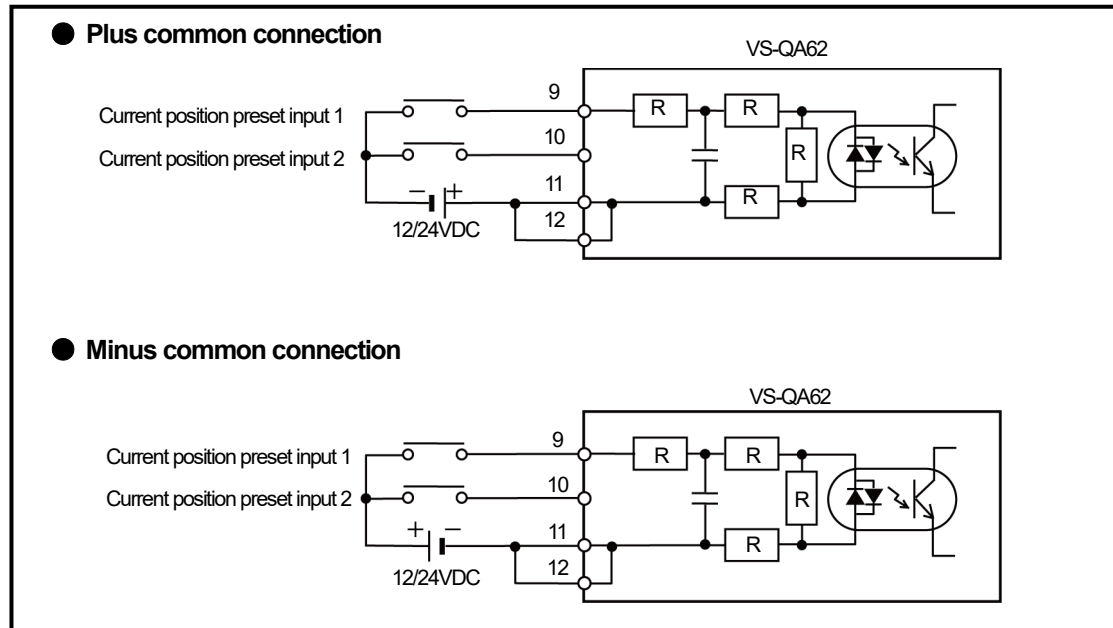

(2) Output circuit (limit switch output, positioning)

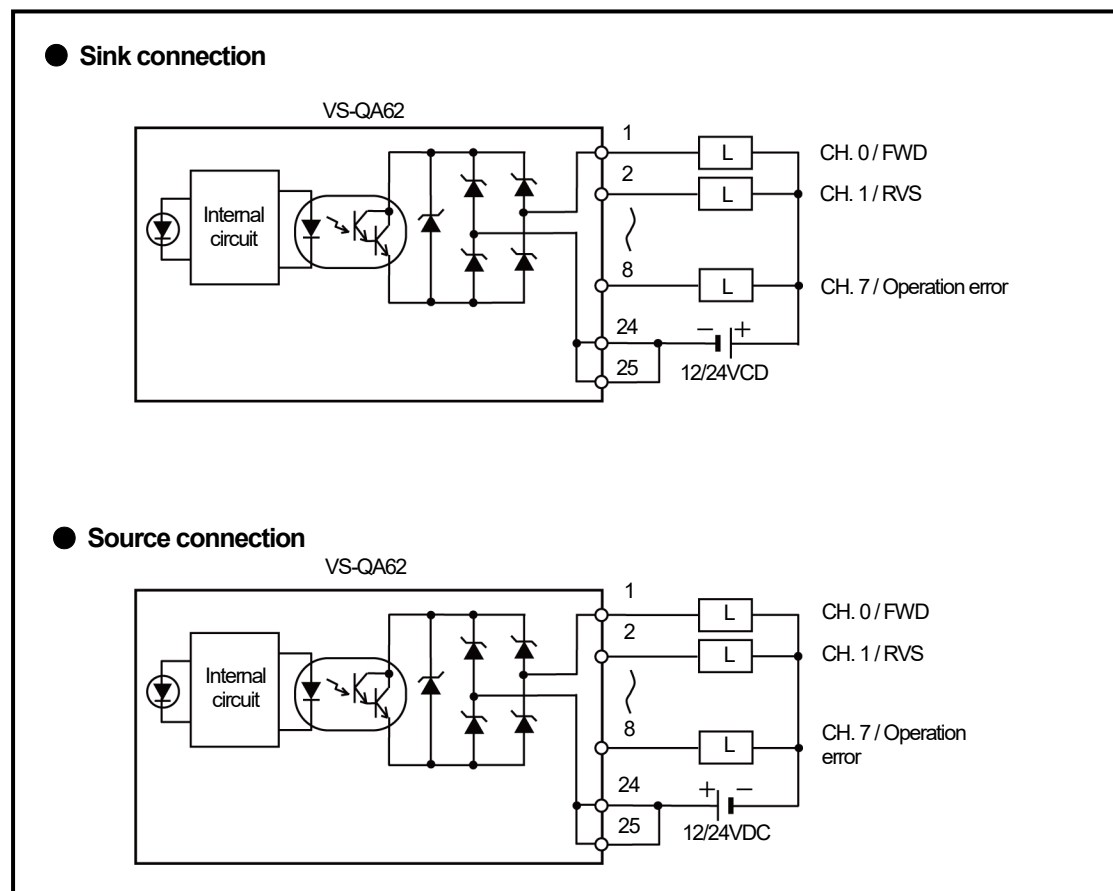

**(3) Pulse output circuit**

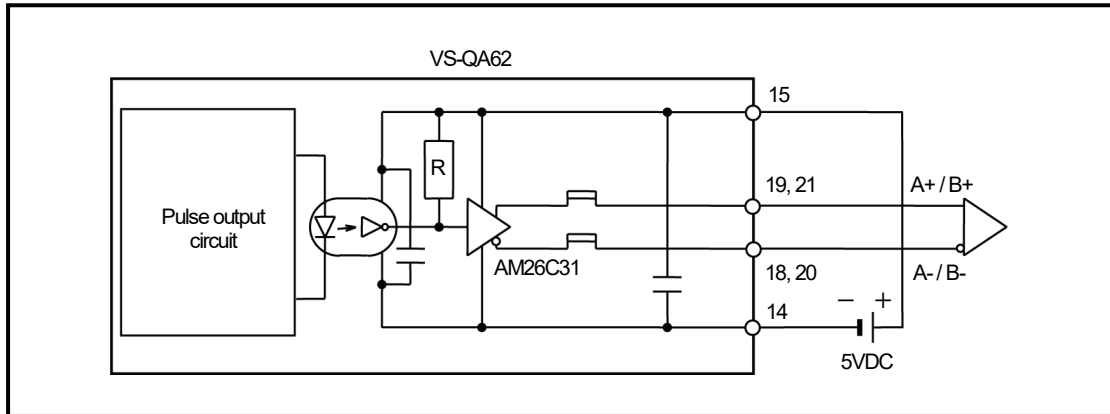

**(4) Analog output circuit**

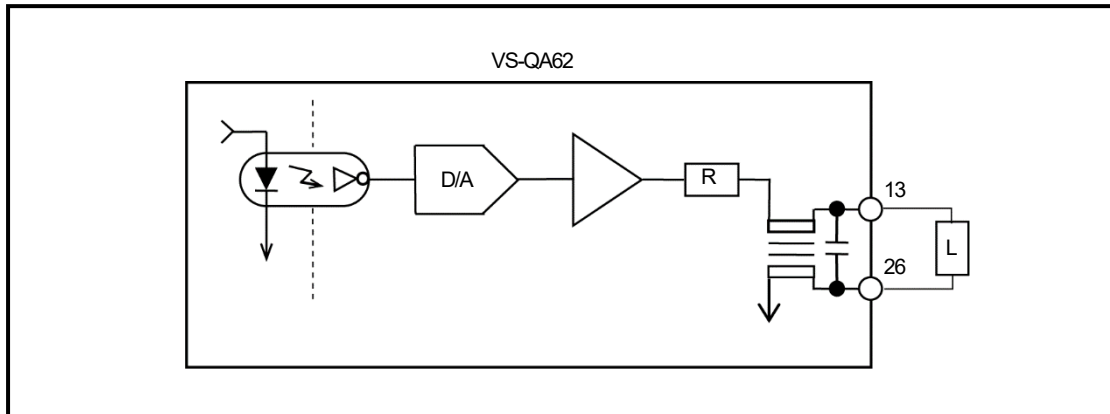

#### 3.5 List of functions

VS-QA62 has many functions based on the position detection as below chart.

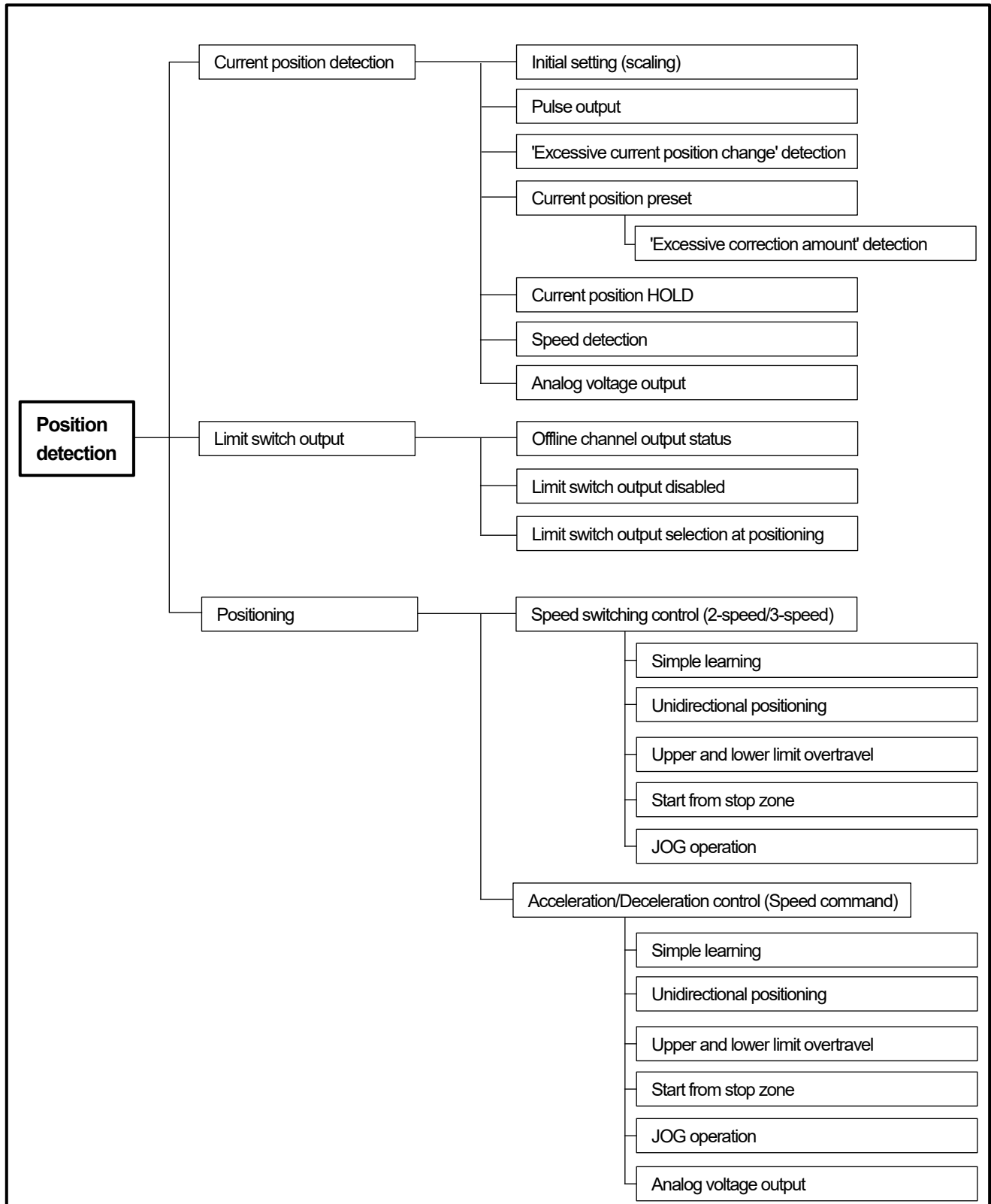

● Function overview

Functions	Contents	Reference (Chapter)
Current position detection	Positions used to be detected by a combination of the incremental type encoder and counter unit. This function detects them with a combination of the ABSOCODER sensor and VS-QA62.	6
Initial setting (scaling)	Position data (binary value) is converted to the length unit such as mm or inch.	6.2
Pulse output	The detected travel amount is output in the A/B phase pulse.	6.4
'Excessive current position change' detection	The current position value is sampled every 20 ms, and the difference between the previously detected current position value and the present value is calculated. The 'excessive current position change' detection function is used to determine whether this difference is within the 'permissible current position change amount' designated by the parameter.	6.5
Current position preset	This function corrects the current position value (scaling binary) to the preset value set in advance by inputting the current position preset signal.	6.6
'Excessive correction amount' detection	This function monitors the corrected amount of the current position value by inputting the current position preset signal.	6.6.3
Current position hold	This function is stored the current position value in the buffer memory when turning ON the preset input signal.	6.7
Speed detection	This function detects the speed of the ABSOCODER sensor.	6.8
Analog voltage output	This function outputs the detected positions or speeds as the analog voltage.	6.9
Limit switch output function	This function compares the current position value (machine position) with the pre-designated ON/OFF value and outputs the limit switch signal.	7
Offline channel output status	This function selects the limit switch output status when offline.	7.4
Limit switch output disabled setting	This function designates for each channel whether or not limit switch output is executed.	7.5
Limit switch output selection at positioning	This function is that the output signal for 6 to 8 pins of the external I/O connector is switched from positioning to outputting the limit switch.	7.6
Positioning function	The positioning function is that stops the machine to the designated position. There are two control formats: the speed switching control and the acceleration/deceleration control.	8 9
Speed switching control	This function executes the speed switching control in order to stop the machine at the target stop position (target value). Control formats are the speed switching format (2-speed) and speed stepping format (3-speed).	8.2
Simple learning	When a positional discrepancy occurs between the target stop position and the current position upon completion of positioning, the discrepancy will be automatically corrected for the next positioning.	8.2.3
Unidirectional positioning	Positioning of VS-QA62 can be executed in one single direction to the target value only.	8.3
Upper and lower limit overtravel detection	This function monitors whether the current position value has exceeded the upper or lower limit value.	8.5
Start from stop zone setting	This function can start a positioning operation from inside the stop zone.	8.6
JOG operation	This function makes travel the machine to designated direction during JOG signal of FWD or RVS is ON.	8.8
Acceleration/Deceleration control	The speed command that the machine's maximum speed was converted to 100% outputs. The speed outputs each 1%, so the machine can be smoothly accelerated or decelerated the speed. The speed command is output to the analog voltage or buffer memory.	9
Simple learning	When a positional discrepancy occurs between the target stop position and the current position upon completion of positioning, the discrepancy will be automatically corrected for the next positioning.	9.2.1
Unidirectional positioning	Positioning of VS-QA62 can be executed in one single direction to the target value only.	9.3
Upper and lower limit overtravel detection	This function monitors whether the current position value has exceeded the upper and lower limit value.	9.5
Start from stop zone setting	This function can start a positioning operation from inside the stop zone.	9.6
JOG operation	This function makes travel the machine to designated direction during JOG signal of FWD or RVS is ON.	9.10
Analog voltage output	This function outputs the speed command as the analog voltage.	9.8

#### 3.6 Specifications of Input/Output Signal with Programmable Controller CPU

##### 3.6.1 List of input/output signals with programmable controller CPU

Input/output signals between VS-QA62 and the PLC CPU are executed according to the following format:

Input: 32 points    Output: 32 points

Input/output signal configuration when VS-QA62 is installed at the base unit's Slot 0.

In the table below, the input/output signals are classified as follows:

- (a) Device X: Input signals from VS-QA62 to the PLC CPU.
- (b) Device Y: Output signals from the PLC CPU to VS-QA62.

Signal direction : VS-QA62 → PLC CPU								
Device No.	Signal name							
X0	Unit ready (VS-QA62 detection item)							
X1	VS-QA62 operation status (online/offline)							
X2	'Upper limit overtravel' detection							
X3	'Lower limit overtravel' detection							
X4	Sensor error detection							
X5	'Excessive correction amount' detection							
X6	'Excessive current position change' detection							
X7	Error detection							
X8	For limit switch output	Channel 0	For positioning (Speed switching format)	FWD	For positioning (Speed stepping format)	FWD/Low-speed	For positioning (Acceleration/Deceleration control format)	FWD
X9		Channel 1		RVS		RVS/Low-speed		RVS
XA		Channel 2		High-speed		High-speed		Not used
XB		Channel 3		Low-speed		Medium-speed		Not used
XC		Channel 4		Brake release		Brake release		Brake release
XD		Channel 5		In-position		In-position		In-position
XE		Channel 6		Positioning in progress		Positioning in progress		Positioning in progress
XF		Channel 7		Operation error		Operation error		Operation error
X10~X1F								

Signal direction : PLC CPU → VS-QA62	
Device No.	Signal name
Y0~YF	Use Prohibited
Y10	PLC ready
Y11	Positioning START (leading edge)
Y12	Positioning STOP
Y13	FWD (Forward) JOG (operation occurs when ON)
Y14	RVS (Reverse) JOG (operation occurs when ON)
Y15	Limit switch output enabled
Y16	Error reset (leading edge)
Y17	Current position preset 1 prohibit/ current position preset command (leading edge)
Y18	Current position preset 2 prohibit
Y19~Y1F	Use Prohibited

**IMPORTANT**

VS-QA62's operation cannot be guaranteed when ON/OFF switching of [Y0 to YF] and [Y19 to Y1F] are executed by the sequence program.

When 'Current position preset' for the sequence format is active by parameter setting, Y17 serves as 'Current position preset command (leading edge)'.

#### 3.6.2 Details of input signal (VS-QA62 → Programmable controller CPU)

The ON/OFF timing and other conditions for I/O signal are explained below.

##### (1) Unit ready (X0)

This signal comes OFF when a watchdog timer error is detected by VS-QA62's self-diagnosis function. When 'X0' comes OFF, this indicates a VS-QA62 hardware error.

##### (2) VS-QA62 operation status (online/offline) (X1)

When the 'PLC ready' signal (Y10) is turned ON, VS-QA62 will be set to 'online' status, and 'X1' will turn ON. 'X1' will go OFF when 'Y10' is turned OFF.

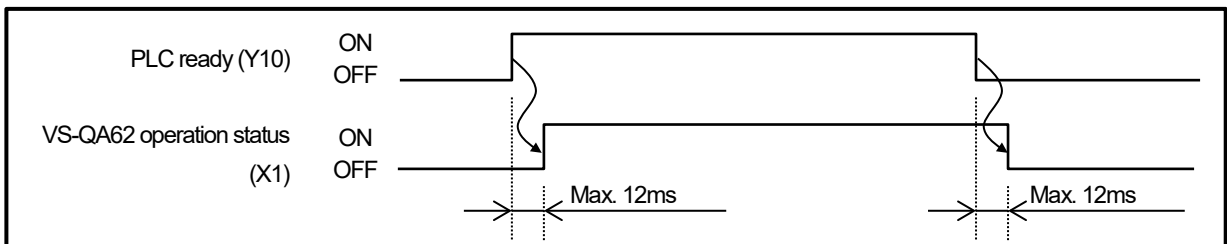

##### (3) 'Upper limit overtravel' detection (X2)

This signal turns ON when the current position value exceeds the upper limit value designated by the parameter. At this time, signals are output from VS-QA62 to externally as it is.

Also, VS-QA62 operation doesn't affect.

Upper limit overtravel is detected only during an 'online' status.

After the current position value has been corrected within the prescribed range, 'X2' will go OFF if 'Y16' (error reset signal) is turned ON (leading edge).

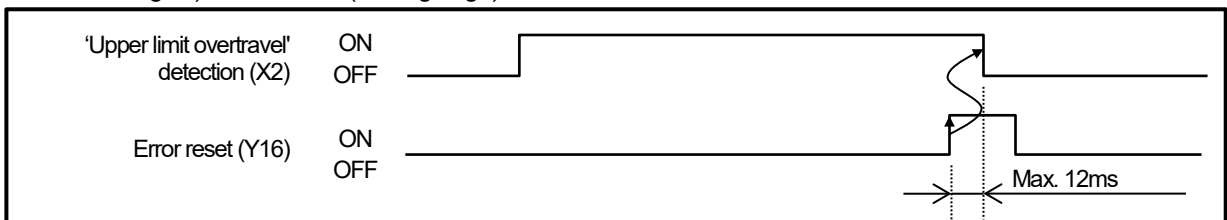

##### (4) 'Lower limit overtravel' detection (X3)

This signal turns ON when the current position value falls below the lower limit value designated by the parameter.

At this time, signals are output from VS-QA62 to externally as it is.

Also, VS-QA62 operation doesn't affect.

Lower limit overtravel is detected only during an 'online' status.

After the current position value has been corrected within the prescribed range, 'X3' will go OFF if 'Y16' (error reset signal) is turned ON (leading edge).

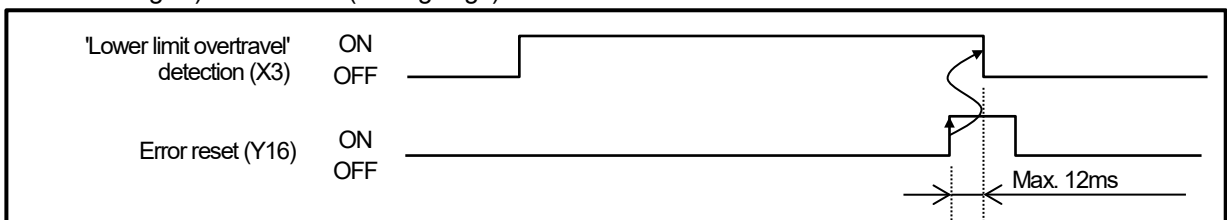

**(5) Sensor error detection (X4)**

This signal turns ON when an error occurs in ABSOCODER's position detection system due to a disconnected ABSOCODER cable, etc.

After the problem has been corrected, 'X4' will go OFF when 'Y16' (error reset signal) is turned ON (leading edge).

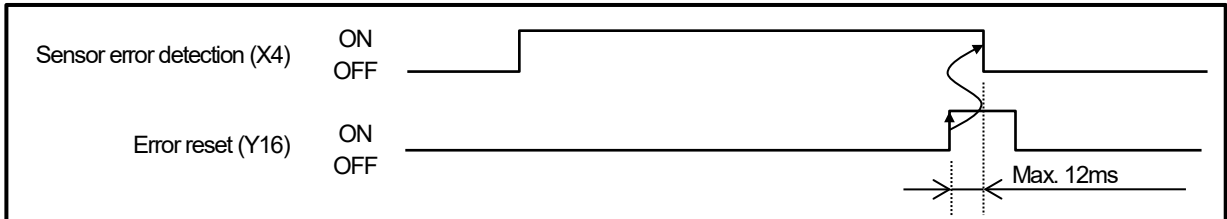

**(6) 'Excessive correction amount' detection (X5)**

This signal turns ON when the change amount of the current position value corrected by the current position preset input signal exceeds the 'Permissible correction amount' (Address 738 and 739) designated by the parameter.

Even when X5 turns ON, the current position value is preset, and VS-QA62 continues to operate.

'X5' will go OFF if 'Y16' (error reset signal) is turned ON (leading edge).

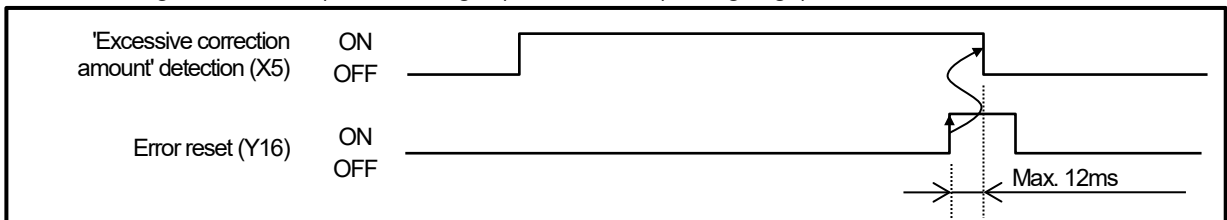

**(7) 'Excessive current position change' detection (X6)**

This signal turns ON when the change amount (change value for each 20ms) of the current position value (scaling binary) exceeds the 'permissible current position change amount' (Address 736 and 737) designated by the parameter.

Even when X6 turns ON, positioning and limit switch functions continue the respective works.

'X6' will go OFF if 'Y16' (error reset signal) is turned ON (leading edge).

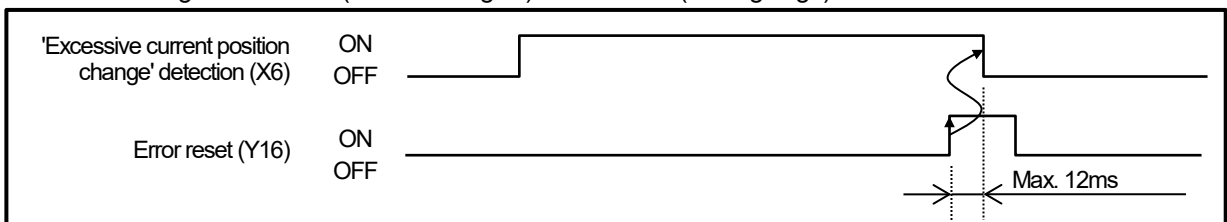

**(8) Error detection (X7)**

This signal turns ON when any of the X2, X3, X4, X5, and X6 signals turns ON, or when any of the errors shown in "Chapter10.1" occurs.

After the problem has been corrected, 'X7' will go OFF when 'Y16' (error rest signal) is turned ON (leading edge).

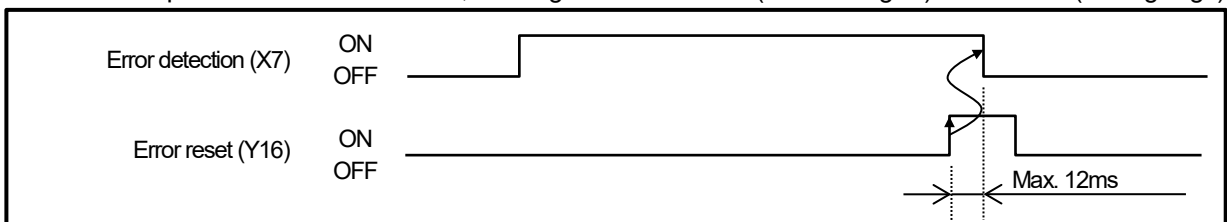

**(9) ON/OFF status detection of the limit switch output or positioning output (X8 to XF)**

In the 'output signal selection' of the buffer memory (Address 711), signals are output from channels 0 to 7 when the limit switch output function is selected.

The motor control signals (FWD, RVS, or etc...) are output when the positioning output is selected.



3.6.3 Details of output signals (Programmable controller CPU → VS-QA62)

(1) 'PLC ready' signal (Y10):

This signal is used to switch the VS-QA62 operation status (online/offline) (X1).

Y10 ON·········· Online

Y10 OFF·········· Offline

The difference between the 'online' and 'offline' status is shown below.

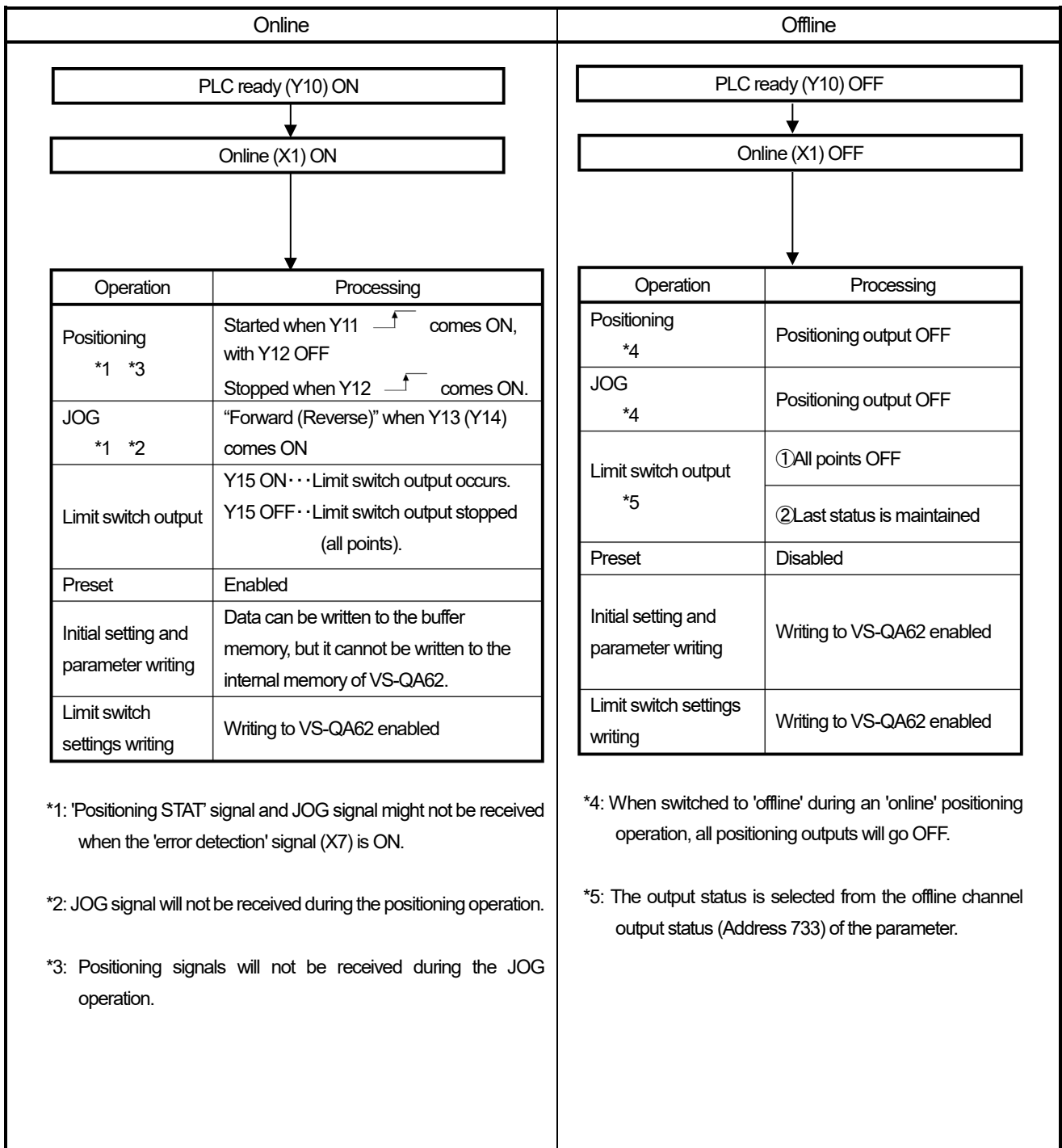

**(2) 'Positioning START' signal (Y11)**

This signal starts the positioning operation.

Under meeting the following condition, the motor control signal for the positioning is output when Y11 is turned ON (leading edge);

- ① Online status (Y11 is ON)
- ② Y12 (positioning STOP signal) is OFF.
- ③ The 'operation error' signal is OFF.
- ④ No 'sensor error' occurs (error code 22).
- ⑤ Not in the JOG operation

**(3) 'Positioning STOP' signal (Y12)**

This signal stops the positioning operation.

When Y12 is turned ON, the positioning operation stops. All the outputs for positioning are turned OFF.

**(4) 'FWD (Forward) JOG' signal (Y13)**

This is the FWD (forward direction) JOG signal.

During online, VS-QA62 will keep the FWD signal ON as long as Y13 is kept ON.

Even when Y13 is turned ON during the positioning operation, it will be invalid.

**(5) 'RVS (Reverse) JOG' signal (Y14)**

This is the RVS (reverse direction) JOG signal.

During online, VS-QA62 will keep the RVS signal ON as long as Y14 is kept ON.

Even when Y14 is turned ON during the positioning operation, it will be invalid.

**(6) 'Limit switch output enabled' signal (Y15)**

When Y15 is turned ON during online, VS-QA62 will output limit switch signals.

When Y15 is turned OFF, all the outputs of the limit switch signal are turned OFF.

**(7) 'Error reset' signal (Y16)**

The following operation error signals will be reset after the cause of the error has been corrected, and Y16 has been turned ON (leading edge).

The error code which has been stored in the buffer memory (Address 7) will also be cleared (0) at this time.

Y16 should be turned OFF when resetting again.

X2 ('Upper limit overtravel' detection)

X3 ('Lower limit overtravel' detection)

X4 (Sensor error detection)

X5 ('Excessive correction amount' detection)

X6 ('Excessive current position change' detection)

X7 (Error detection)

**(8) Current position preset prohibit 1 / current position preset command signal (Y17)**

The 'current position preset input 1' of the external I/O connector is invalid when Y17 is turned ON if the following items are designated at the current position preset function of the parameter (Address 748).

- 1 (parameter format)
- 2 (buffer memory format)

The current position preset is executed when Y17 is turned ON (leading edge) if 3 (sequence format) is designated.

**(9) Current position preset prohibit 2 signal (Y18)**

The 'current position preset input 2' of the external I/O connector is invalid when Y18 is turned ON if the following items are designated at the current position preset function of the parameter (Address 748).

- 1 (parameter format)
- 2 (buffer memory format)

#### 3.7 Buffer Memory List

VS-QA62 contains a buffer memory which is used for data communication with the PLC CPU.

The buffer memory configuration is shown below.

The buffer memory used for each function and the reference chapter for the detailed explanation are shown.

Data readout of all areas can be executed by the sequence program.

1/4

Address (decimal)	Reference for each function (chapter No.)					Writing conditions by sequence program	
		Current position detection	Limit switch output	Positioning			
				2-speed /3-speed control	Acceleration /Deceleration control		
0	(L) Current position value (scaling binary)	6.1	6.1	6.1	6.1	Writing disabled	
1	(H)						
2	(L) Current position value (sensor binary)	6.1					
3	(H)						
4	Limit switch output status		7.7.2				
5	Limit switch writing command answerback		5.4				
6	Input status	6.6.5					
7	Error code	10.1	10.1	10.1	10.1	Writing enabled at any time	
8	Limit switch output disabled setting		7.5				
9	Limit switch writing command		5.4				
10	(L) Target stop position setting data			8.7.2	9.9.2		
11	(H) (scaling binary)						
12	Limit switch output selection when positioning		7.6			Writing enabled at any time  *1	
13	Not used						
14	CH. 0	(L) Number of multi-dogs		7.1			
15		(H)					
16		(L) Dog 0 ON position		7.1			
17		(H) setting data					
18		(L) Dog 0 OFF position		7.1			
19		(H) setting data					
34	CH. 1	(L) Dog 4 OFF position		7.1			
35		(H) setting data					
36		CH. 2	(L) Number of multi-dogs		7.1		
37			(H)				
38			(L) Dog 0 ON position		7.1		
39			(H) setting data				
40	(L) Dog 0 OFF position			7.1			
41	(H) setting data						
56	CH. 15	(L) Dog 4 OFF position		7.1			
57		(H) setting data					
58		CH. 2	(L) Number of multi-dogs		7.1		
59			(H)				
60			(L) Dog 0 ON position		7.1		
61			(H) setting data				
62	(L) Dog 0 OFF position			7.1			
63	(H) setting data						
362	CH. 15	(L) Dog 4 ON position		7.1			
363		(H) setting data					
364		(L) Dog 4 OFF position		7.1			
365		(H) setting data					

\*1: The setting value isn't written to the VS-QA62 until 1 is written in the limit switch writing command (Address 9).

### 3. VS-QA62 SPECIFICATIONS

MELSEC-Q

2/4

Address (decimal)		Reference for each function (chapter No.)				Writing conditions by sequence program
		Current position detection	Limit switch output	Positioning		
				2-speed /3-speed control	Acceleration /Deceleration control	
366	Not used					
367	(L) Maximum speed				9.7.2	Writing enabled at any time  *2
368	(H) Maximum speed				9.7.2	
369	Speed limit				9.7.2	
370	(L) Maximum speed reach timer				9.7.2	
371	(H) Maximum speed reach timer				9.7.2	
372	Bias speed when positioning starts				9.7.2	
373	(L) Speed command ON delay timer				9.7.2	
374	(H) Speed command ON delay timer				9.7.2	
375	(L) Brake release ON delay timer				9.7.2	
376	(H) Brake release ON delay timer				9.7.2	
377	(L) Deceleration timer				9.7.2	
378	(H) Deceleration timer				9.7.2	
379	(L) Brake release OFF zone				9.7.2	
380	(H) Brake release OFF zone				9.7.2	
381	(L) Creep zone				9.7.2	
382	(H) Creep zone				9.7.2	
383	(L) FWD stop zone				9.7.2	
384	(H) FWD stop zone				9.7.2	
385	(L) RVS stop zone				9.7.2	
386	(H) RVS stop zone				9.7.2	
387	Creep speed				9.7.2	
388	(L) Stop timer				9.7.3	
389	(H) Stop timer				9.7.3	
390	Deceleration end speed				9.7.3	
391	(L) Reverse delay time				9.7.4	
392	(H) Reverse delay time				9.7.4	
393	Initialization command of 'stop zone after learning'				9.2.1	
394	Not used					
⋮						
⋮						
667						

\*2: The setting value is written to the internal memory of VS-QA62 when the positioning START signal (Y11) is turned ON.

### 3. VS-QA62 SPECIFICATIONS

MELSEC-Q

3/4

Address (decimal)		Reference for each function (chapter No.)				Writing conditions by sequence program	
		Current position detection	Limit switch output	Positioning			
				2-speed /3-speed control	Acceleration /Deceleration control		
668	(L)	Speed output	6.8.2			Writing disabled	
669	(H)						
670	(L)	Hold current position (scaling binary)	6.7				
671	(H)						
672	(L)	Hold current position (sensor binary)	6.7				
673	(H)						
674	(L)	FWD stop zone after learning		8.2.3			
675	(H)						
676	(L)	RVS stop zone after learning		8.2.3			
677	(H)						
678		Speed limit		8.4.4		Writing enabled at any time  *3	
679		Positioning pattern data buffer memory selection		8.4.1			
680	(L)	Medium-speed zone		8.4.3			
681	(H)						
682	(L)	Low-speed zone		8.4.3			
683	(H)						
684	(L)	FWD stop zone		8.4.3			
685	(H)						
686	(L)	RVS stop zone		8.4.3			
687	(H)						
688	(L)	In-position zone		8.4.3	9.4		
689	(H)						
690	(L)	Current position preset value 1	6.6.2			Writing enabled at any time	
691	(H)						
692	(L)	Current position preset value 2	6.6.2				
693	(H)						
694		Not used				Writing disabled	
695		Not used					
696		Positioning output status		8.7.4	9.9.3		
697		Speed command (with sign)			9.9.4		
698		Speed command (absolute value)			9.9.4		
699		Not used					
700		Data memory flag	5.3	5.3	5.3	5.3	Writing enabled
701		Data memory flag answerback	5.3	5.3	5.3	5.3	Writing disabled
702		Sensor rotation direction	6.2.2	6.2.2	6.2.2	6.2.2	<b>(Initial setting)</b>
703		Not used					Writing enabled at any time  *4
704	(L)	Scale length	6.2.3	6.2.3	6.2.3	6.2.3	
705	(H)						
706	(L)	Minimum current position value	6.2.4	6.2.4	6.2.4	6.2.4	
707	(H)						
708	(L)	Current position value	6.2.5	6.2.5	6.2.5	6.2.5	
709	(H)						
710		Current position change command	5.3.1 5.3.3	5.3.1 5.3.3	5.3.1 5.3.3	5.3.1 5.3.3	

\*3: The setting value is written to the internal memory of VS-QA62 when the positioning START signal (Y11) is turned ON.

\*4: However, the setting value isn't written to the internal memory of VS-QA62 until the initial setting bit of the data memory flag (Address 700) is designated "1" offline.

### 3. VS-QA62 SPECIFICATIONS

MELSEC-Q

4/4

Address (decimal)		Reference for each function (chapter No.)				Writing conditions by sequence program	
		Current position detection	Limit switch output	Positioning			
				2-speed /3-speed control	Acceleration /Deceleration control		
711	Output signal selection	7.3	7.3	7.3	7.3	(Parameter)	
712	Positioning format			8.2	9.2		
713	Positioning direction			8.3	9.3		
714	(L) Overshoot amount			8.3	9.3		
715	(H) Overshoot amount						
716	(L) Medium-speed zone			8.4.2			
717	(H) Medium-speed zone						
718	(L) Low-speed zone			8.4.2			
719	(H) Low-speed zone						
720	(L) Stop zone			8.4.2			
721	(H) Stop zone						
722	(L) In-position zone			8.4.2	9.4		
723	(H) In-position zone						
724	(L) Upper limit value			8.5	9.5		
725	(H) Upper limit value						
726	(L) Lower limit value			8.5	9.5		
727	(H) Lower limit value						
728	Start from stop zone			8.6	9.6		
729	Motion non-detection timer			8.9	9.11		
730	Motion misdirection non-detection timer			8.9	9.11		
731	Positioning end detection timer			8.7.3	9.7.4		
732	JOG low-speed timer			8.8	9.10		
733	Offline channel output status		7.4				
734	(L) Pulse output count setting value	6.4.1					Writing enabled at any time  *5
735	(H) Pulse output count setting value						
736	(L) Permissible current position change amount	6.5					
737	(H) Permissible current position change amount						
738	(L) Permissible correction amount	6.6.3					
739	(H) Permissible correction amount						
740	(L) FWD current position preset value 1	6.6.2					
741	(H) FWD current position preset value 1						
742	(L) RVS current position preset value 1	6.6.2					
743	(H) RVS current position preset value 1						
744	(L) FWD current position preset value 2	6.6.2					
745	(H) FWD current position preset value 2						
746	(L) RVS current position preset value 2	6.6.2					
747	(H) RVS current position preset value 2						
748	Current position preset function	6.6.1					
749	Speed gate time	6.8.1					
750	Speed sampling time	6.8.1					
751	Analog output data selection	6.9.1			9.8.1		
752	(L) Maximum output voltage	6.9.1			9.8.1		
753	(H) Maximum output voltage						
754	(L) Minimum output voltage	6.9.1			9.8.1		
755	(H) Minimum output voltage						
756	(L) Maximum output value	6.9.1			9.8.1		
757	(H) Maximum output value						
758	(L) Minimum output value	6.9.1			9.8.1		
759	(H) Minimum output value						
760	JOG low-speed				9.10		
761	JOG high-speed				9.10		

\*5: However, the setting value isn't written to the internal memory of VS-QA62 until the parameter bit of the data memory flag (Address 700) is designated "1" offline.

### 4. HANDLING AND WIRING

This section explains how to unpack and connect VS-QA62.

#### 4.1 VS-QA62 Handling Precautions

The following precautions should be observed when handling VS-QA62.

- (1) As VS-QA62 is constructed from a resin-based material, it should not be dropped or subjected to severe shocks.
- (2) Never remove the PCBs from VS-QA62's case.  
Failure to do so may result in failure.
- (3) Turn OFF the PLC power supply before mounting and removing VS-QA62 to and from the base unit.
- (4) During the wiring procedure, do not allow any foreign object (e.g. wire strips, etc.) to get into VS-QA62.  
The top part of VS-QA62 is particularly vulnerable.
- (5) Tighten the VS-QA62 securing screws (M3) within the torque range of 0.36 to 0.48N·m.

#### 4.2 Wiring Precautions

The following wiring precautions should be observed when connecting the VS-QA62 to external devices.

- (1) Each signal lines of external I/O connector and ABSOCODER cable should be located as far as possible from power lines and other lines which generate a high level of electrical noise.  
If location near the above power lines is unavoidable, the cable duct should be separated, with individual wiring conduits being provided.
- (2) When wiring conduits are used, they should be securely grounded.



4.3 Precautions for Installation of ABSOCODER Sensors

4.3.1 ABSOCODER sensor installation

● Handling of ABSOCODER Sensor

Item	Explanation
(1) Main unit	<p>Never drop the Sensor, or subject it to excessive forces or shocks.</p>
(2) Cable	<p>Avoid stepping on, or applying excessive stress to the cable.</p>

● Mounting of ABSOCODER Sensor

Item	Explanation	Precaution
(1) Mounting	For details regarding mounting dimensions, refer to each ABSOCODER sensor dimensions.	
(2) Cable port	<p>Cable port should face downward.</p>	
(3) Cable	<p>The bend radius for movable parts should never be less than 75 mm (<math>\phi 150</math>) (robotic cable).</p>	Do not use the standard cable for movable parts. (Use robotic cable.)
(4) Wiring	<p>The sensor cable should be located at least 300mm away from power lines and other lines which generate a high level of electrical noise.</p>	

● Mounting of ABSOCODER Sensor

Item	Explanation	Precaution
(1) Coupling of machine shaft and sensor shaft	<p>Be sure to use a coupling device to link the 2 shafts.</p>	<p>A "direct-link" format will result in shaft fatigue and / or breakage after long periods. Therefore, be sure to use a coupling device to link the shafts.</p>
(2) For gear-type linkage	<p>If a gear linkage is used, be sure that some backlash exists.</p>	<p>Incorrect gear mounting can result in shaft bending or breakage.</p>
(3) For rack and pinion type linkage	<p>Be sure that backlash exists at all rack positions.</p>	<p>Incorrect rack and pinion mounting can result in shaft bending or breakage.</p>
(4) Chain or timing belt linkage	<p>When a chain or timing belt linkage format is used, there is an inherent risk of the shaft's load being increased by the resulting tension. Therefore, a bearing should be used, with the shafts being linked by a coupling device immediately behind the bearing.</p> <p><b>Recommended format</b> ○</p> <p><b>Bad format</b> ✕</p> <p>This linkage format is also applicable to the "rack-and-pinion" and "gear" methods shown above.</p> <p>Even a small amount of tension can produce a considerable load on the shaft.</p>	
(5) Shaft mounting position	<p>The shaft should be attached to the coupling device or gear at a point which is as near to the sensor body as possible.</p> <p><b>Recommended format</b> ○</p> <p><b>Bad format</b> ✕</p> <p>Coupling device or</p> <p>This distance should be as short as possible. When this distance is short, the load placed on the bearing by vibrations / shocks is slight.</p> <p>Never use an extended shaft format.</p>	

● Coupling of ABSOCODER Sensor

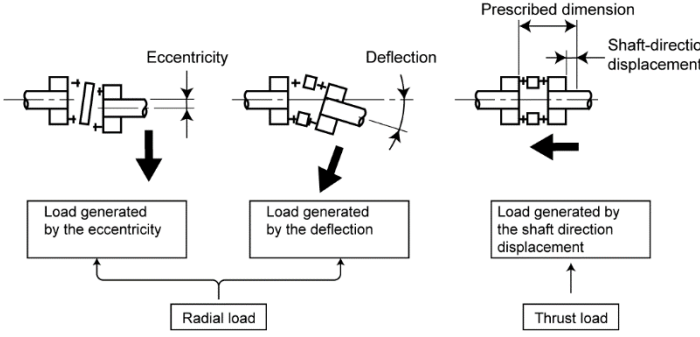
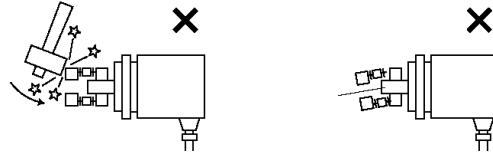
Item	Explanation	Precaution
<p>(1) Coupling device selection precaution</p>	<p>1. Selection of the coupling device should be based on the following factors;</p> <ul style="list-style-type: none"> <li>- The amount of a mounting error caused by the machine design.</li> <li>- The permissible error of coupling device.</li> <li>- Reaction force of coupling device.</li> <li>- Permissible shaft load of the sensor.</li> </ul> <div style="display: flex; justify-content: space-around; align-items: center; margin: 10px 0;"> <div style="border: 1px solid black; padding: 2px; font-size: 8px;">The amount of a mounting error caused by the machine design</div> <div style="font-size: 24px;">&lt;</div> <div style="border: 1px solid black; padding: 2px; font-size: 8px;">The permissible error of the coupling device</div> <div style="font-size: 24px;">&lt;</div> <div style="border: 1px solid black; padding: 2px; font-size: 8px;">Reaction force of the coupling device</div> <div style="font-size: 24px;">&lt;</div> <div style="border: 1px solid black; padding: 2px; font-size: 8px;">Permissible shaft load of the sensor</div> </div> <p><b>Mounting error</b></p>  <p>2. If the selected coupling device is larger than necessary (When used in high vibration/shock environments), the load which is applied to the shaft by the vibrations/shocks will be increased by the weight of the coupling device.</p> <p>3. Be sure to select a coupling device with an adequate transmission torque surplus relative to the sensor shaft's torque.</p>	<p>The selection of a larger coupling than necessary will increase the shaft load which is caused by the mounting error amount.</p> <p>Excessive force applied to the shaft can deform the coupling and reduce durability.</p>
<p>(2) Coupling device installation precaution</p>	<p>Avoid bending or damaging the coupling.</p> 	

### 4.3.2 Precautions for connecting ABSOCODER sensors

- (1) Connection should be made using the ABSOCODER cable, with the connector being securely tightened.
- (2) If further length is desired, an extension cable must be ordered separately.  
Refer to “APPENDIX 3” for details regarding extension cables.
- (3) The maximum length for which extension is possible varies according to the ABSOCODER sensor model which is used.  
Refer to “APPENDIX 2” for details.
- (4) A robotic cable must be used if the ABSOCODER cable is to be used at a movable area of the system.  
In such a case, the cable should never be bent to from a radius of less than 75mm.

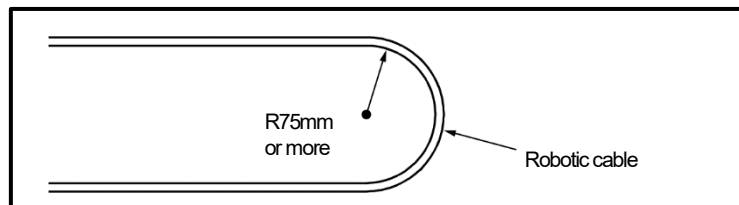



## 5. SETUP AND PROCEDURES BEFORE OPERATION

### 5.1 Name of Parts and Functions

The illustration below shows the nomenclature of VS-QA62.

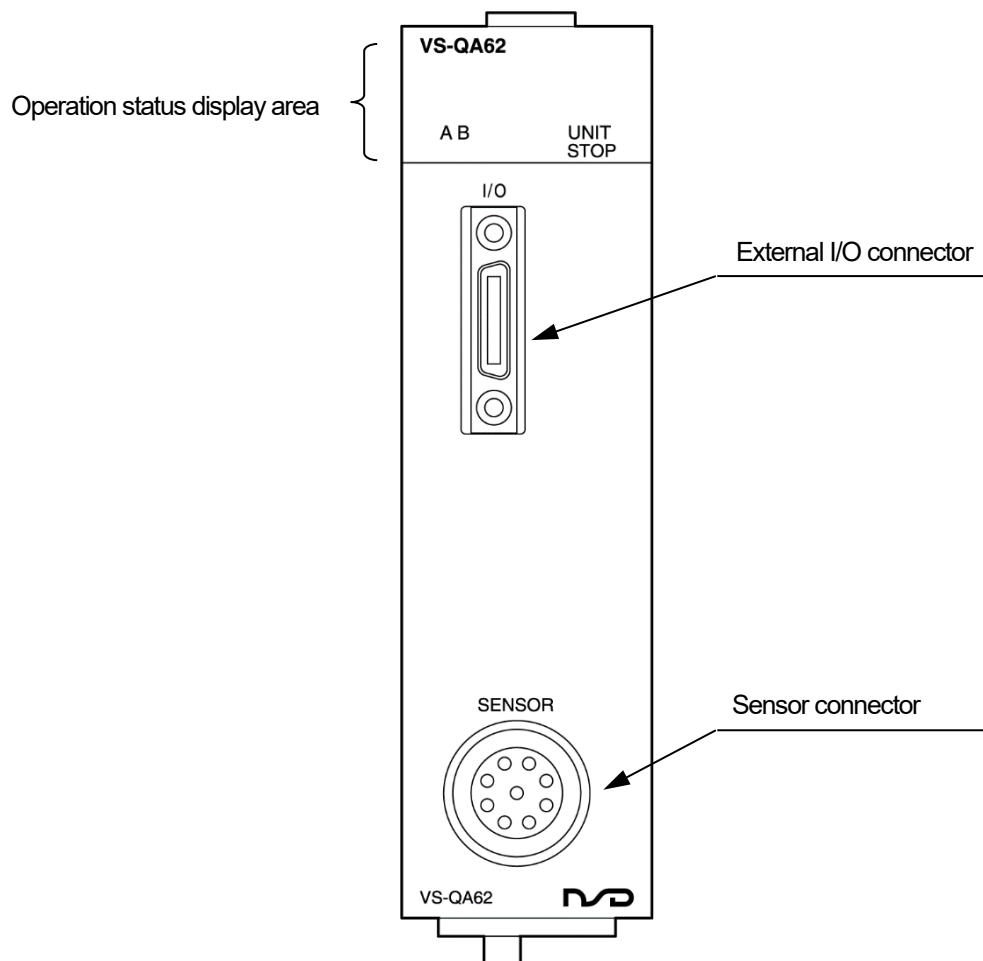

## 5. SETUP AND PROCEDURES BEFORE OPERATION

MELSEC-Q

### ● Details of Operation Status Display Area

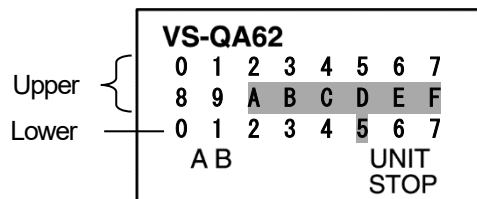

#### Upper: 0 to 9

LED	For current position detection	Signal name			
		For limit switch output	For positioning		
			Speed switching format	Speed stepping format	Acceleration /Deceleration format
0	OFF	CH.0	FWD	FWD/low-speed	FWD
1	OFF	CH.1	RVS	RVS/low-speed	RVS
2	OFF	CH.2	High-speed	High-speed	Not used ( OFF)
3	OFF	CH.3	Low-speed	Medium-speed	Not used ( OFF)
4	OFF	CH.4	Brake release		
5	OFF	CH.5	In-position [CH.5] *1		
6	OFF	CH.6	Positioning in progress [CH.6] *1		
7	OFF	CH.7	Operation error [CH.7] *1		
8	Current position preset input 1				
9	Current position preset input 2				

\*1: The signal can be switched to the limit switch output signal by the 'limit switch output selection when positioning' of the buffer memory (Address 12).

#### Lower: 0 to 4 (●: LED is ON)

LED	Buffer memory writing disabled errors	Upper limit overtravel	Lower limit overtravel	Sensor error	Excessive correction amount	Excessive current position change	Learning data error	Unacceptance of the start	Target value error	Motion detection error	Motion direction error	Detection range over	Preset value error	Data error	Limit switch setting error	Buffer memory data errors
0	●		●		●		●		●		●		●		●	
1		●	●			●	●			●	●			●	●	
2				●	●	●	●					●	●	●	●	
3								●	●	●	●	●	●	●	●	
4																●

#### Lower: 6 to B

LED	Display contents	
6	LED turns ON or blinks when an error occurs.	ON: VS-QA62 has an error. Blink (1s): The sequence program has an error. Blink (0.3s): The CPU has an error.
7	LED turns ON when the VS-QA62 operation status is online (X1).	
A	LED indicates the output status of the A phase pulse.	
B	LED indicates the output status of the B phase pulse.	

#### UNIT STOP

LED	Display contents
UNIT STOP	LED turns ON when the unit ready signal (X0) is OFF (HW error).

## 5.2 Procedure Before the Operation

This chapter explains procedures until starting to operate VS-QA62.

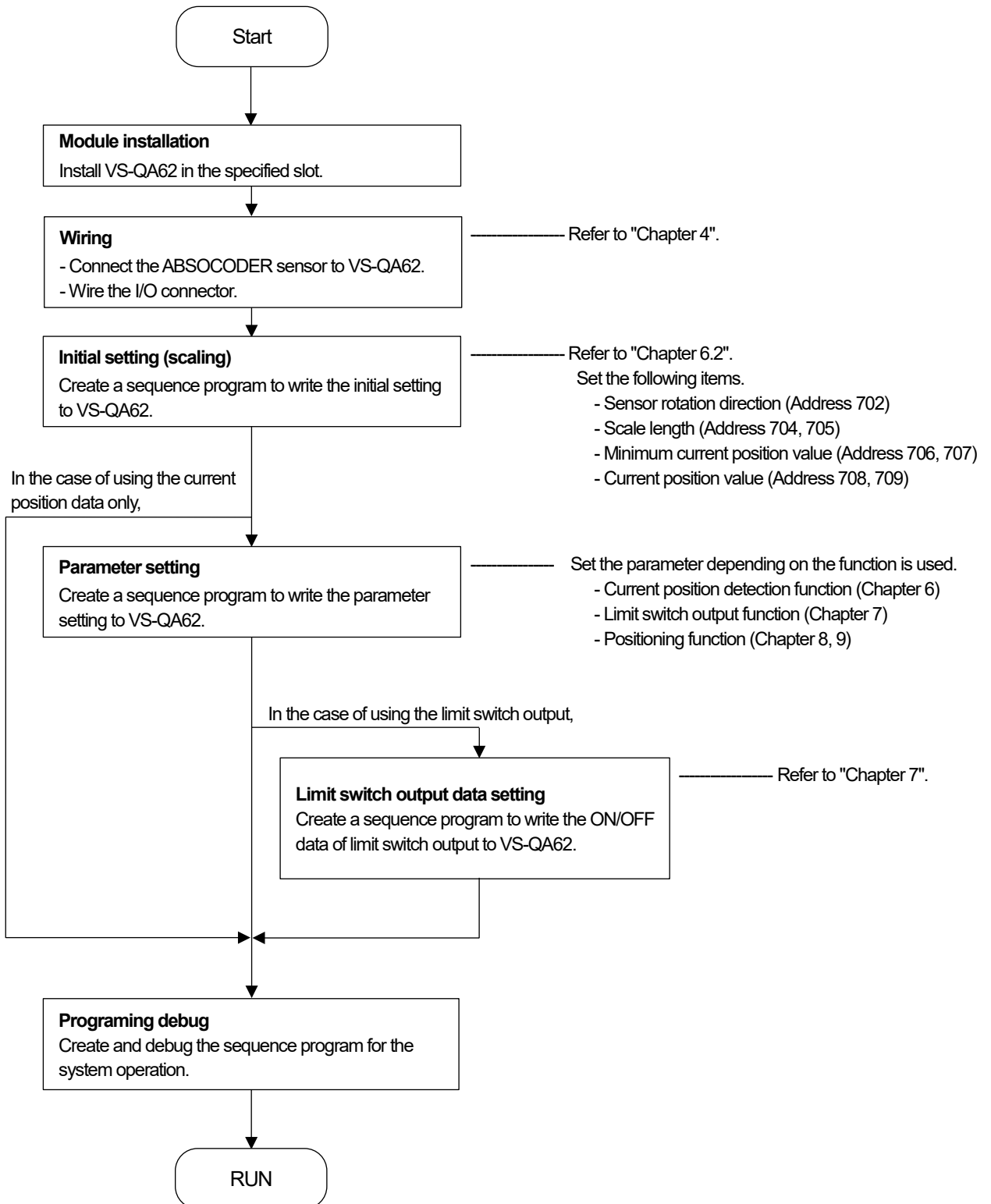



### 5.3 Procedures for the Initial and Parameter Settings

This chapter explains how to designate the initial and parameter settings.

The setting value is stored in the internal memory of VS-QA62 when setting the initial setting area (Address 702 to 709) and the parameter area (Address 711 to 761) of the buffer memory.

The written data in the internal memory won't be deleted even when the power supply of the PLC is turned OFF.

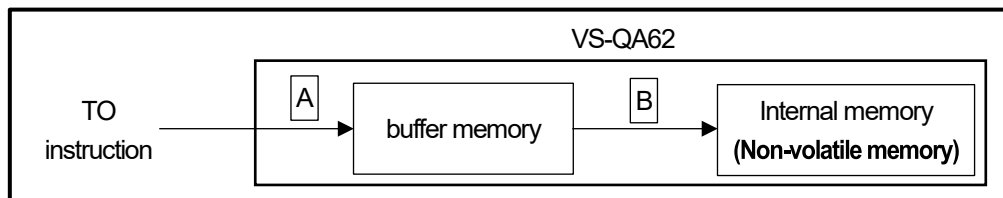

Refer to 'Chapter 5.3.1' for procedures for the initial setting.

Refer to 'Chapter 5.3.2' for the procedures for the parameter area settings.

Refer to 'Chapter 5.3.3' for the procedures when setting initial and parameter simultaneously.

NSD has a sample program of setting procedures. Refer to 'Appendix 8.2' for details.

## 5.3.1 Procedures for the initial settings

### Point

\*1: Procedure ①, ④ and ⑦

Those procedures are executed only when the current position value (Address 708 and 709) is written into the internal memory.

Other initial settings (Address 702 to 707) don't need those procedures.

### ● Writing process

① Move the machine to the reference position. \*1

② Turn OFF the PLC ready (Y10) in order to be offline.

③ Write the setting value to the initial setting area (Address 702 to 709). **A**

④ Write '1' to the current position change command (Address 710). **B** \*1

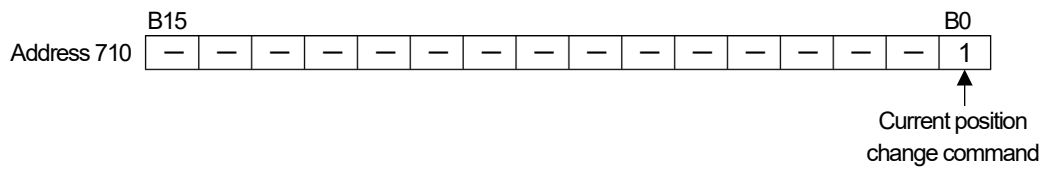

⑤ Write '16' to the data memory flag (Address 700) after confirming VS-QA62 is offline (X1: OFF). **B**

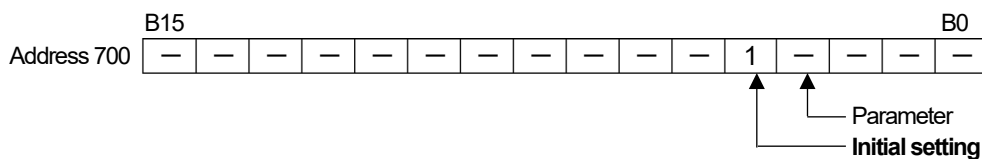

⑥ '16' is returned in the data memory flag answerback (Address 701) after the completion of writing the value normally.

At this time, the setting value is stored in the internal memory.

In addition, the current position values (scaling binary) (Address 0 and 1) are changed to the values designated in Address 708 and 709.

### Point

"The setting value has an error if '16' isn't returned in the data memory flag answerback.

Check the error code (Address 7) of the buffer memory.

The error code is a value that 1000 is added to the applicable buffer memory address.

- ⑦ Write '0' to the current position change command (Address 710). \*1
- ⑧ Write '0' to the data memory flag (Address 700).
- ⑨ Turn ON the PLC ready (Y10) in order to be online.
- ⑩ The operation status (X1) is turned ON, and back to online.

● **Timing chart**

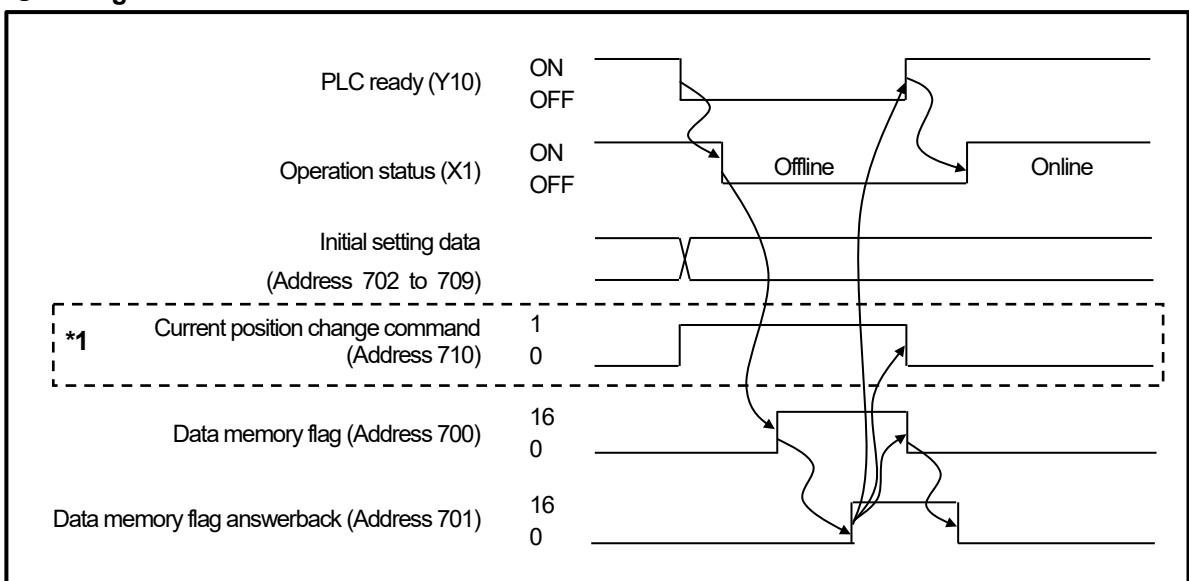

**Point**

The ABSOCODER sensor should be connected to VS-QA62 only when the current position value (Address 708 and 709) is designated. Other initial settings (Address 702 to 707) can be designated without connecting the ABSOCODER sensor.

## 5.3.2 Procedures for parameter settings

**Point**

The ABSOCODER sensor isn't needed to connect to VS-QA62 when setting parameters (Address 711 to 761).

● **Writing procedure**

- ① Turn OFF the PLC ready (Y10) in order to be offline.
- ② Write the setting value to the parameter area (Address 711 to 761). **A**
- ③ Write '8' to the data memory flag (Address 700) after confirming VS-QA62 is offline (X1: OFF). **B**

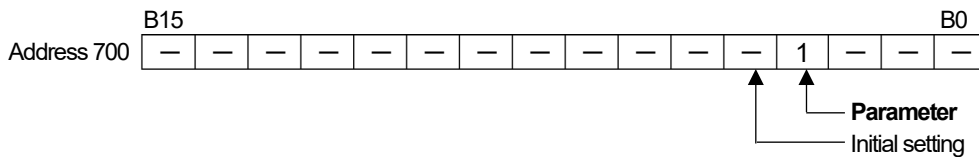

- ④ '8' is returned in the data memory flag answerback (Address 701) after the completion of writing the value normally.  
At this time, the setting value is stored in the internal memory.

**Point**

The setting value has an error if '8' isn't returned in the data memory flag answerback. Check the error code (Address 7) of the buffer memory. The error code is a value that 1000 is added to the applicable buffer memory address.

- ⑤ Write '0' to the data memory flag (Address 700).
- ⑥ Turn ON the PLC ready (Y10) in order to be online.
- ⑦ The operation status (X1) is turned ON, and back to online.

● **Timing chart**

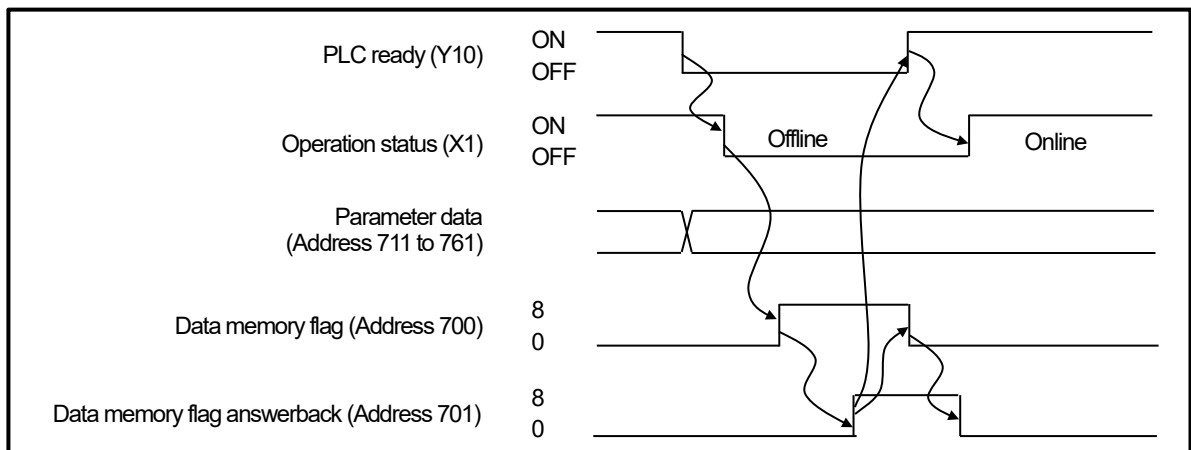

## 5.3.3 Procedures when setting initial and parameter simultaneously

**Point**

\*1: Procedure ①, ④ and ⑦

Those procedures are executed only when the current position value (Address 708 and 709) is written into the internal memory.

Other initial settings (Address 702 to 707) don't need those procedures.

● **Writing procedures**

① Move the machine to the reference position. \*1

② Turn OFF the PLC ready (Y10) in order to be offline.

③ Write the setting value to the initial setting area (Address 702 to 709) and parameter area (Address 711 to 761). **A**

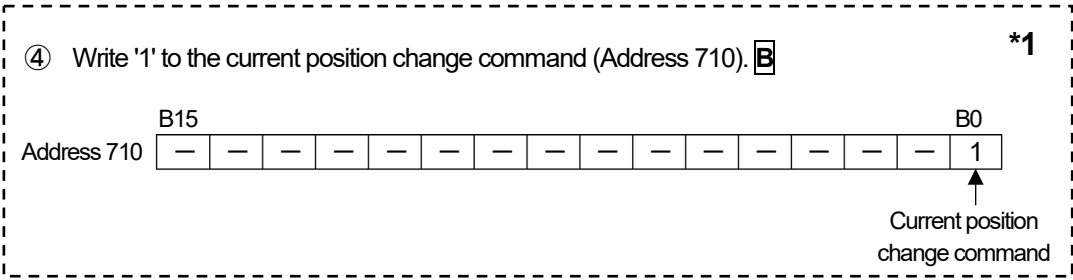

⑤ Write '24' to the data memory flag (Address 700) after confirming VS-QA62 is offline (X1: OFF). **B**

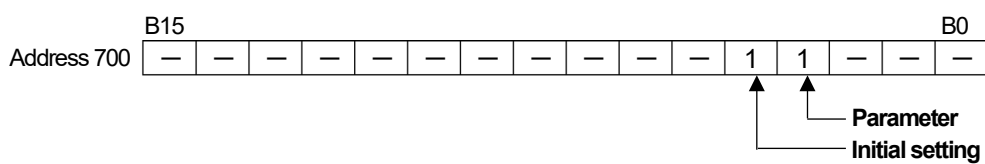

⑥ '24' is returned in the data memory flag answerback (Address 701) after the completion of writing the value normally.

At this time, the setting value is stored in the internal memory.

In addition, the current position values (scaling binary) (Address 0 and 1) are changed to the values designated in Address 708 and 709.

**Point**

The setting value has an error if '24' isn't returned in the data memory flag answerback.

Check the error code (Address 7) of the buffer memory.

The error code is a value that 1000 is added to the applicable buffer memory address.

- ⑦ Write '0' to the current position change command (Address 710). \*1
- ⑧ Write '0' to the data memory flag (Address 700).
- ⑨ Turn ON the PLC ready (Y10) in order to be online.
- ⑩ The operation status (X1) is turned ON, and back to online.

● **Timing chart**

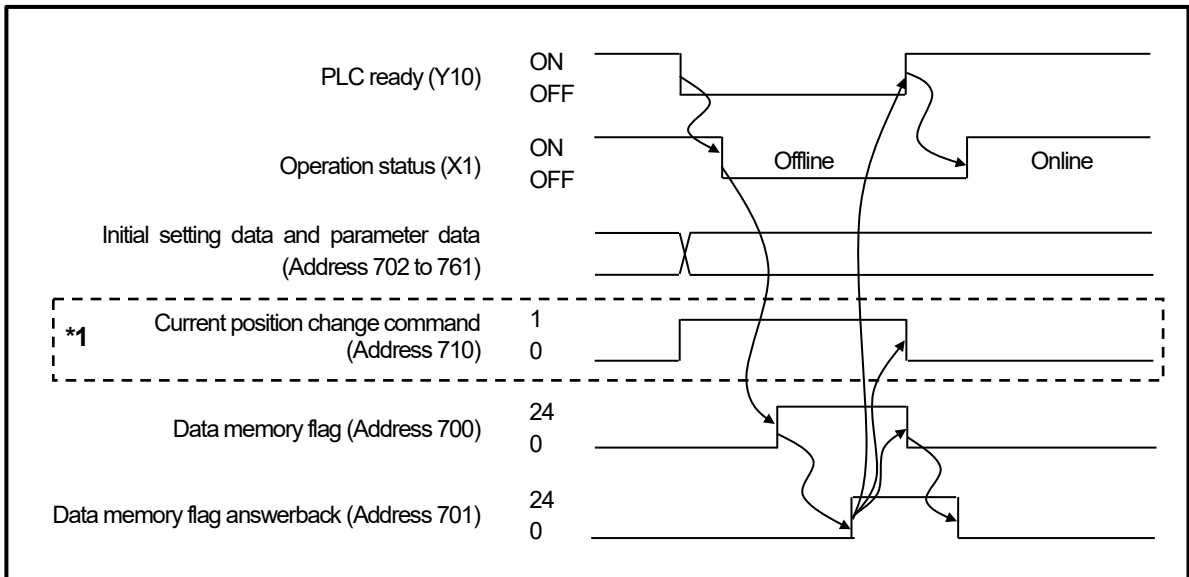

**Point**

The ABSOCODER sensor should be connected to VS-QA62 only when the current position value (Address 708 and 709) is designated.  
 Other initial settings and parameters (Address 702 to 707 and 711 to 761) can be designated without connecting the ABSOCODER sensor.

### 5.3.4 Readout procedures for the initial and parameter settings

The readout method of the initial and parameter settings is explained in this chapter.

The setting values of the initial and parameter settings stored in the internal memory can be read out to the buffer memory.

The readout destination is the initial setting area (Address 702 to 709) and parameter area (Address 711 to 761).

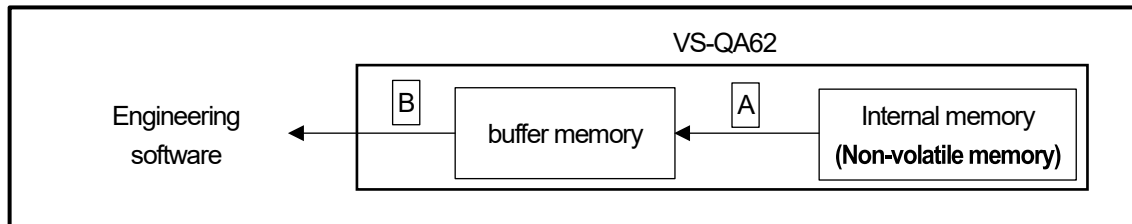

#### ● Readout procedure

- ① Switch the PLC CPU switch to 'STOP', and stop the sequence program.
- ② In the ① status, turn ON the power supply of the PLC again. **A**  
The setting value is read out from the internal memory to the buffer memory.
- ③ Check the contents of the buffer memory by using engineering software such as GX Developer. **B**

## 5.4 Setting Procedures for the Limit Switch Output Data

This chapter explains the setting method of the limit switch output data.

The setting value is stored in the internal memory of VS-QA62 when setting ON/OFF data (Address 14 to 365) of the limit switch output.

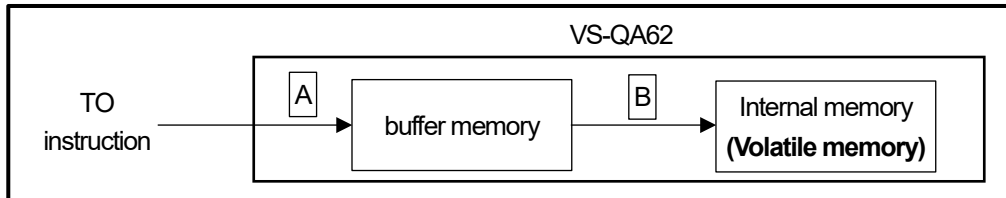

### ● Writing procedure

- ① Online/offline  
The limit switch data can be written to the internal memory in the status both online and offline.
- ② Write the setting value to the limit switch data area (Address 14 to 365). **A**
- ③ Write '1' to the limit switch writing command (Address 9) in order to store the setting value in the internal memory. **B**

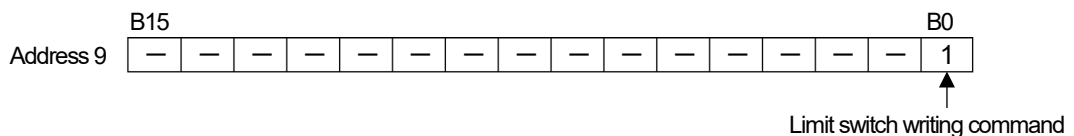

- ④ '1' is returned in the limit switch writing command answerback (Address 5) after the completion of writing the value normally.

#### Point

The setting value has an error if '1' isn't returned in the limit switch writing command answerback. Check the error code (Address 7) of the buffer memory. The error code is a value that 1000 is added to the applicable buffer memory address.

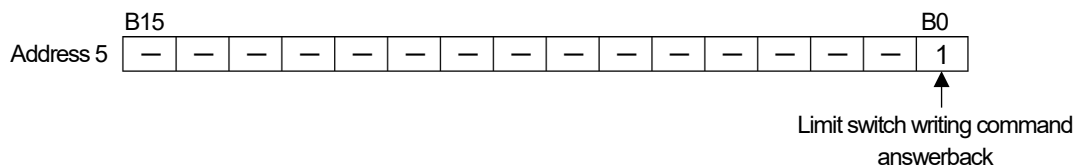

- ⑤ Write '0' to the limit switch writing command (Address 9).

### ● Timing chart

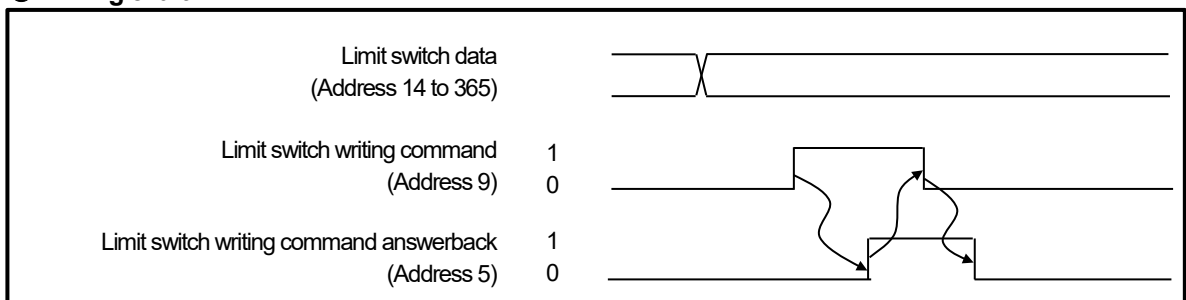



**IMPORTANT**

- ON/OFF data of the limit switch output written in the internal memory cannot be read out.
- The data is deleted when the power supply of the PLC is turned OFF because the internal memory is not backed up.  
Manage the ON / OFF data of the limit switch output by the sequence program.

6. CURRENT POSITION DETECTION FUNCTION

The current position detection function detects the position data by combining the ABSOCODER sensor with VS-QA62. Conventionally, the position data was detected using an incremental format encoder in combination with a counter unit.

The position data can be read out from the 'current position value' of the buffer memory. The current position value has two kinds; sensor binary and scaling binary.

For more details, refer to 'Chapter 6.1'.

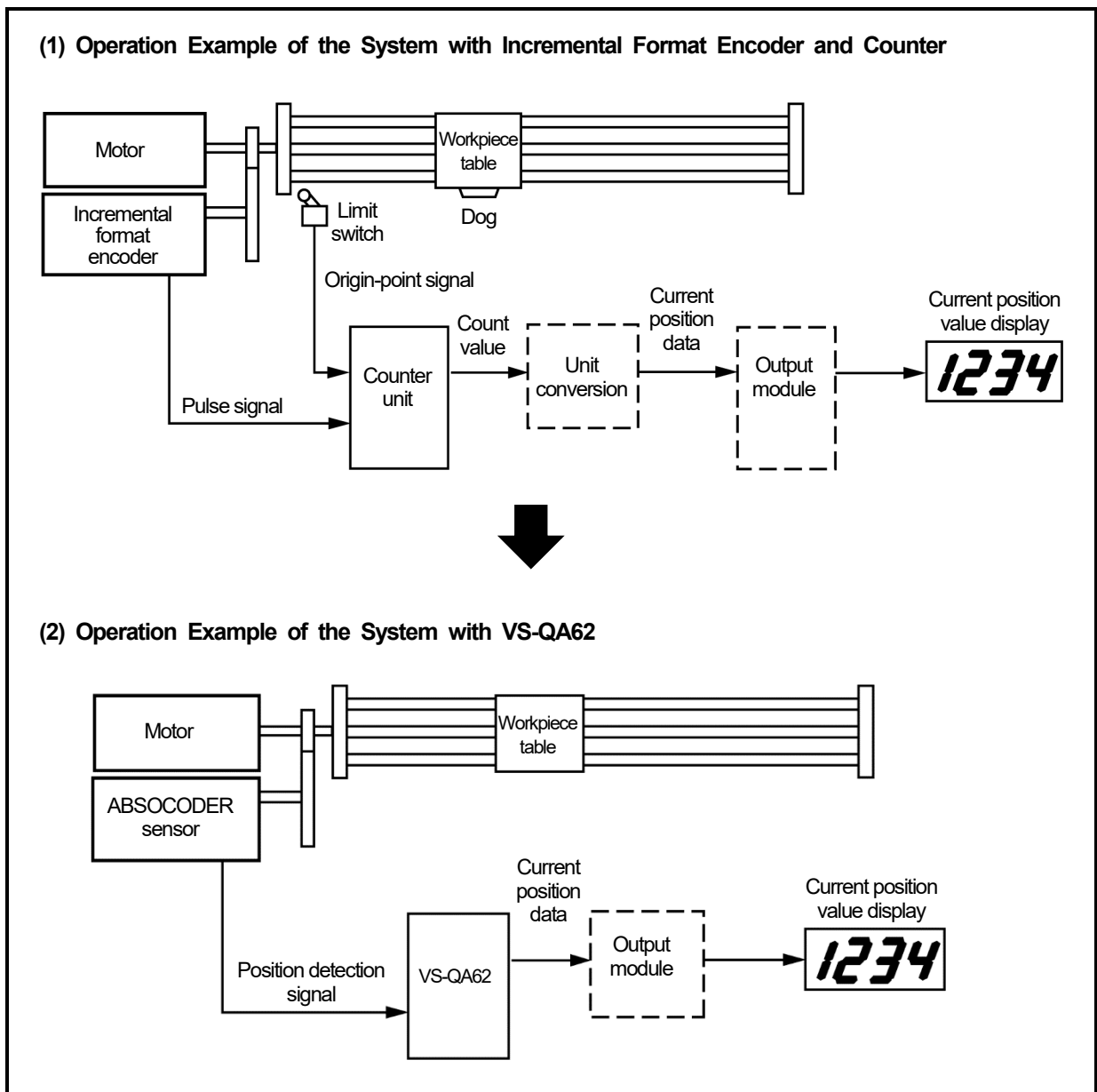

### 6.1 Current Position Value

● **Sensor binary value (Address 2 and 3 of the buffer memory)**

This value is counted inside of VS-QA62 when the ABSOCODER sensor shaft rotates. It changed from 0 to 131071 (0 to 1FFFFH) when the shaft rotates from 0 to the 'total number of turns'. The 'total number of turns' is decided based on the sensor model.  
Ex: MRE-32SP062, The 'total number of turns' is 32.

● **Scaling binary value (Address 0 and 1 of the buffer memory)**

The value is converted into a unit such as mm or inch based on the sensor binary value by setting the scale length and minimum current position value. This value indicates the machine's current position. The value would be stored as two's complement if this value is 'negative value'.

$$\text{Scaling binary value} = \frac{\text{Scale length}}{131072} \times \text{Sensor binary value} + \text{Minimum current position value}$$

**<Example>**

In the following condition, the following figure indicates the relation between the sensor binary and scaling binary value.

**Condition**

- Sensor: MRE-32SP062
- Scale length: 32000 (Detection range: 320.00mm)
- Minimum current position value: -1000 (Minimum value: -10.00mm)
- Machine's current position: 150.00mm

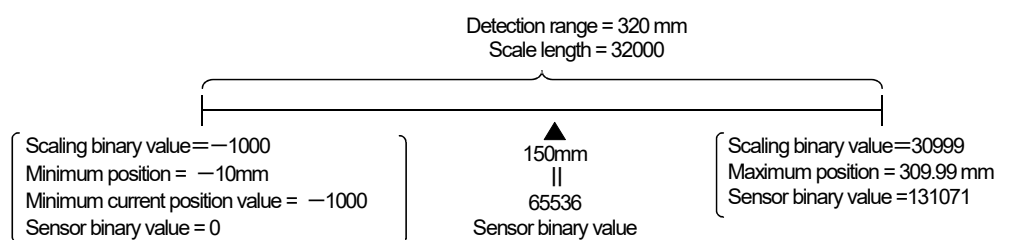

The scaling binary value at the 150 mm position will be as follows:

$$\begin{aligned} \text{Scaling binary value} &= \frac{32000}{131072} \times 65536 - 1000 \\ &= 15000 \end{aligned}$$

**Point**

Both the sensor binary value and the scaling binary value can be changed as your desired value by using the initial setting function or the current position 'PRESET' function.

## 6.2 Initial Setting Function (Scaling)

The initial setting function is that position data (binary value) detected by the ABSOCODER sensor is converted to a length unit such as mm or inch.

The converted data can be read out from the 'current position value (scaling binary) (Address 0 and 1)' of the buffer memory.

This setting should be done at first after the purchase.

### 6.2.1 Initial setting list

The initial setting list is indicated in the following table.

For more details, refer to reference chapter.

Address	Item	Contents	Setting range	Default	Reference (Chapter No.)
702	Sensor rotation direction	Select the rotation (travel) direction of the ABSOCODER sensor shaft in which the current position value increases.	0: CW 1: CCW	0	6.2.2
704(L) 705(H)	Scale length (L)	Designate the longest distance that is detectable by the ABSOCODER sensor.	1000 to 999999	131072	6.2.3
706(L) 707(H)	Minimum current position value (K)	Designate the smallest current position value (scaling binary).	[−99999 to (1000000−L)]	0	6.2.4
708(L) 709(H)	Current position value	Designate a value that indicates the current machine position.	K to (K+L−1)	65536	6.2.5

### 6.2.2 Sensor shaft rotation direction (Address 702)

Depending on the direction in which the ABSOCODER sensor shaft rotates, the current position value will increase or decrease.

The direction of rotation in which the current position value increases can be designated as either 'CW' or 'CCW' as desired.

- 0 (CW setting) : Current position value will increase when the sensor shaft rotates CW (viewed from shaft end).
- 1 (CCW setting) : Current position value will increase when the sensor shaft rotates CCW (viewed from shaft end).

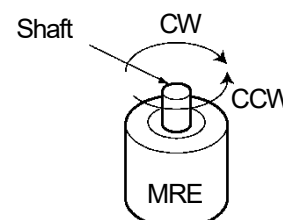

#### Point

"Current position value" refers to the following address.

- Scaling binary value (Addresses 0 and 1 of the buffer memory)
- Sensor binary value (Addresses 2 and 3 of the buffer memory)

### 6.2.3 Scale length (Address 704 and 705)

This is the maximum distance over which the ABSOCODER sensor can perform absolute position detection. The scale length can be specified in a system-of-units that is appropriate to the machine's travel amount. With multi-turn type ABSOCODER sensors (the MRE Series), the scale length is the amount of machine travel attained after the sensor shaft has completed a total number of turns (32, 64, 128, 160, 256, 320).

**<Example>**

Given a 10mm lead ballscrew feed mechanism with a direct coupling to a 32-turn MRE, and with the drive device's minimum setting unit being 0.01mm, the scale length (L) can be calculated as shown below.

$$\text{Actual detection distance} = [10\text{mm} / \text{turn}] \times [32 \text{ turns}] = 320\text{mm}$$

$$\text{Scale length (L)} = \frac{\text{Actual detection distance}}{\text{Minimum setting unit}} \qquad L = \frac{320}{0.01} = 32000$$

**Point**

A decimal point isn't output.

**IMPORTANT**

The current position value cannot be counted correctly if the setting value of the scale length is exceeded the total number of divisions (131072).  
The detection range or 'travel amount per rotation' should be reconsidered if it has a problem.

**IMPORTANT**

As soon as the machine travels out of the detection range, the current position value (scaling binary value) will jump by the whole Scale length.  
Make sure that the machine never travels beyond the detection range.

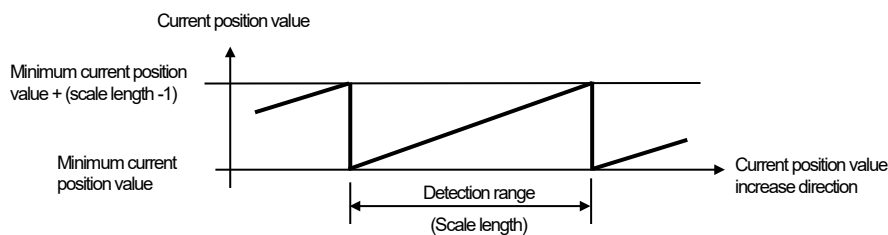

### 6.2.4 Minimum current position value (Address 706 and 707)

This is the minimum value of the current position value which can be detected.

This value can be designated as desired within the following range: -99999 to [1000000—scale length].

**<Example>**

Given the same conditions as those described in 'chapter 6.2.3', and with the actual minimum position of the detection range being -10 mm, the following will apply:

$$\text{Minimum current position value (K)} = \frac{\text{Actual minimum position}}{\text{Minimum setting unit}} \quad K = \frac{-10}{0.01} = -1000$$

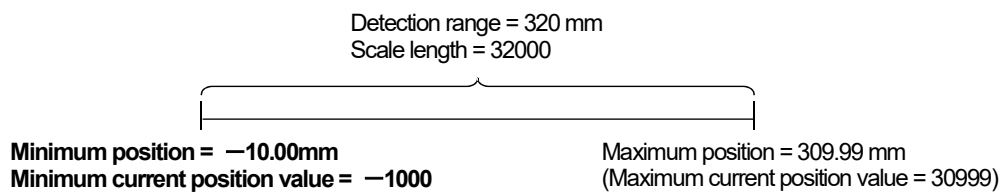

**IMPORTANT**

● **Note for setting the scale length and minimum current position value**

Check whether the following parameter setting value is within the detection range or not when setting the scale length and minimum current position value.

An error occurs if the value is out of the range.

The error code is a value that 1000 is added to the applicable address.

Function	Address	Item	Default
Initial setting	708(L), 709(H)	Current position value	65536
Current position detection function (Parameter)	740(L), 741(H)	FWD current position preset value 1	0
	742(L), 743(H)	RVS current position preset value 1	0
	744(L), 745(H)	FWD current position preset value 2	0
	746(L), 747(H)	RVS current position preset value 2	0

An error occurs when '1' or more value is designated to the current minimum value because the default value of the current position preset value is '0'.

In this case, change the current position preset value within the detection range before the initial setting.

### 6.2.5 Current position value (Address 708 and 709)

The current position value is designated as a value that is indicated where the machine positions in the detection range.

For example, when the machine is moved to its 100 mm position, the 'current position value' which corresponds to that position would be designated as '10000' (when resolution is 0.01).

The value is designated as your desired value within the detection range ([minimum current position value] to [minimum current position value + scale length - 1]).

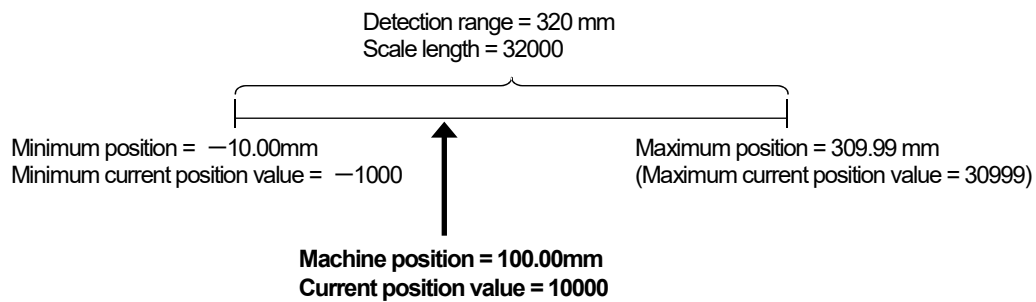

### 6.3. Parameter for Related to the Current Position Detection

The parameters related to the current position detection are indicated below.

They should be set for each function and set them when you need.

For more detailed functions, see the reference chapter.

These function parameters should also be set when using with the limit switch and/or positioning functions.

For the parameter setting procedures, refer to 'Chapter 5.3'.

#### ● Parameter list

1/2

Address	Item	Contents	Setting range	Default	Reference (Chapter No.)
711	Output signal selection	Select the signal contents which are output to the external I/O connector (1 to 8) and device (X8 to XF).	0: Positioning output 1: Limit switch output 2: Current position value detection (No signal output)	2	7.3
734(L) 735(H)	Pulse output count setting value	Designate the pulse number that is output from the external I/O connector. Designate the pulse number that is output in all detection ranges of the ABSOCODER sensor.	1 to 131072	32768	6.4.1
736(L) 737(H)	Permissible current position change amount	Designate the permissible current position change amount.	0 to 999999	999999	6.5
738(L) 739(H)	Permissible correction amount	Designate the permissible correction amount when presetting the current position value.	0 to 999999	999999	6.6.3
740(L) 741(H)	FWD current position preset value 1	The current position value is changed to a value designated at this parameter when the current position preset input 1 is turned ON while the machine travels in the FWD direction.	Minimum current position value to [minimum current position value + scale length -1]	0	6.6.2
742(L) 743(H)	RVS current position preset value 1	The current position value is changed to a value designated at this parameter when the current position preset input 1 is turned ON while the machine travels in the RVS direction.	Minimum current position value to [minimum current position value + scale length -1]	0	6.6.2
744(L) 745(H)	FWD current position preset value 2	The current position value is changed to a value designated at this parameter when the current position preset input 2 is turned ON while the machine travels in the FWD direction.	Minimum current position value to [minimum current position value + scale length -1]	0	6.6.2
746(L) 747(H)	RVS current position preset value 2	The current position value is changed to a value designated at this parameter when the current position preset input 2 is turned ON while the machine travels in the RVS direction.	Minimum current position value to [minimum current position value + scale length -1]	0	6.6.2
748	Current position preset function	Select the current position preset function format.	0: Disabled 1: Parameter format 2: Buffer memory format 3: Sequence format	0	6.6.1
749	Speed gate time	Select the speed gate time for detecting the sensor binary value change amount. (0 to 6) Also, selects the rotation and traveling speeds.	0: 0.8ms 1: 1.6ms 2: 3.2ms 3: 6.4ms 4: 12.8ms 5: 25.6ms 6: 51.2ms 7: Rotation speed (r/min) 8: Travel speed (scale value/s) *1	0	6.8.1
750	Speed sampling time	Select the speed sampling time. However, this parameter is invalid when selecting '7' or '8' in Address 749.	0: Same as speed gate time 1: 1/2 of speed gate time 2: 1/4 of speed gate time	0	6.8.1

\*1: A unit of the 'scale value' is decided depending on the setting of the scale length of the initial setting.

The unit will be mm/s if the scale length is set mm unit.



## 6. CURRENT POSITION DETECTION FUNCTION

MELSEC-Q

2/2

Address	Item	Contents	Setting range	Default	Reference (Chapter No.)
751	Analog output data selection	Select the analog output data.	0: No output (Fixed at 0) 1: Absolute value speed command (0 to 100%) 2: Speed command (-100 to 100%) 3: Current speed *2 4: Current position (scale value)	0	6.9.1
752(L) 753(H)	Maximum output voltage (Vmax)	Designate the analog output maximum voltage.	Vmin to 10.00 [V]	1000	6.9.1
754(L) 755(H)	Minimum output voltage (Vmin)	Designate the analog output minimum voltage.	-10.00 to Vmax [V]	0	6.9.1
756(L) 757(H)	Maximum output value	Designate the <u>value</u> <sup>*3</sup> for outputting maximum voltage.	-999999 to 999999	100	6.9.1
758(L) 759(H)	Minimum output value	Designate the <u>value</u> <sup>*3</sup> for outputting minimum voltage .	-999999 to 999999	0	6.9.1

\*2: The speed unit should be selected at the speed gate time (Address 749).

\*3: The unit of value is varied depending on the data selected in Address 751.

### ● For the current position preset function (RAM area)

This is an area that preset values for the buffer memory or sequence format are stored.

1/1

Address	Item	Contents	Setting range	Default	Reference (Chapter No.)
690(L) 691(H)	Current position preset value 1	This is a preset value for the buffer memory or sequence format. The current position value is changed to a value designated at this parameter when the current position preset input1 or device Y17 is turned ON.	Minimum current position value to [minimum current position value + scale length -1]	0	6.6.2
692(L) 693(H)	Current position preset value 2	This is a preset value for the buffer memory format. The current position value is changed to a value designated at this parameter when the current position preset input 2.	Minimum current position value to [minimum current position value + scale length -1]	0	6.6.2

## 6.4 Pulse Output Function

The pulse output function is that outputs the travel amount of the ABSOCODER sensor as the A/B phase pulse. The pulse is output from the external I/O connector (18 to 21 pins).

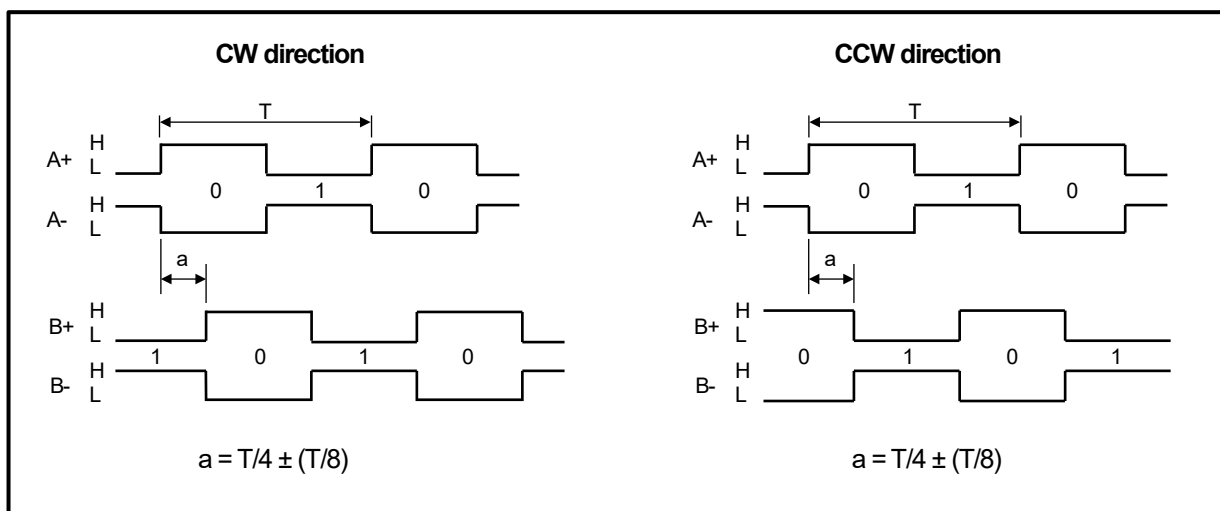

### 6.4.1 Pulse number setting

The pulse number is designated in the below parameter. For the parameter setting procedures, refer to 'Chapter 5.3'.

Address	Item	Contents	Setting range	Default
734(L) 735(H)	Pulse output count setting value	Designate the pulse number that is output from the external I/O connector. Designate the pulse number that is output in all detection ranges of the ABSOCODER sensor.	1 to 131072	32768

## 6.4.2 Operation conditions

### ● Writing timing of the setting value

Maximum 5s requires from designating the parameter writing bit of the data memory flag by TO instruction to outputting pulse normally.

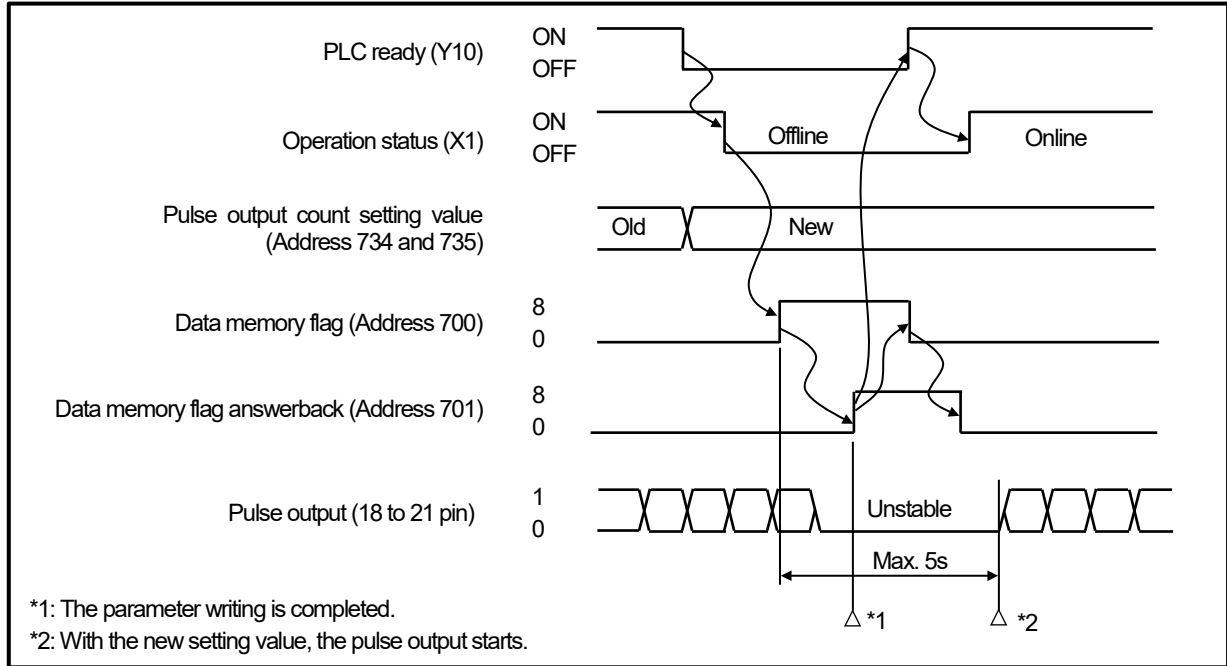

### ● Timing when turning ON the power supply

Maximum 5s requires from turning ON the power supply to outputting pulse normally.

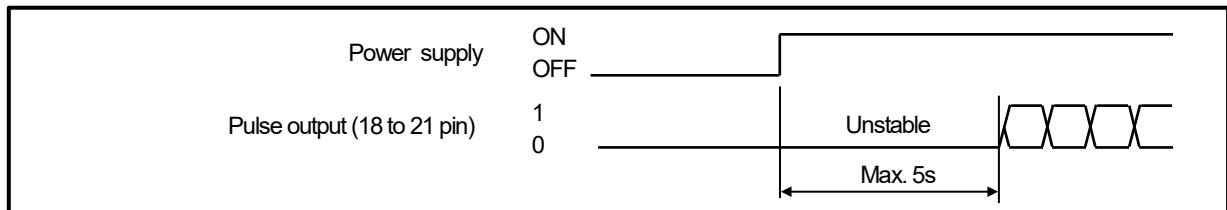

### 6.5 'Excessive Current Position Change' Detection Function

The 'Excessive current position change' detection function samples a current position value every 20ms, and monitors the change amount difference between the current and previous detected values.

The following warning occurs when this value exceeds the 'permissible current position change amount' of parameter (Address 736 and 737);

- Device X6 ('Excessive current position change' detection) is turned ON.
- Error 24 occurs.

The permissible current position change amount is designated in the following parameter.

For the parameter setting procedures, refer to 'Chapter 5.3'.

Address	Item	Contents	Setting range	Default
736(L) 737(H)	Permissible current position change amount	Designate the permissible current position change amount.	0 to 999999	999999

#### (1) Clearing method of the warning

Turn ON (leading edge) Device Y16 (error reset).

#### (2) Operation of the positioning and limit switch functions

The positioning and limit switch functions operate even though 'Excessive current position change' is detected.

#### (3) Change the current position value

A warning doesn't occur when the current position value is changed by using the current position preset or initial setting function.

## 6.6 Current Position 'PRESET' Function

The current position 'PRESET' function corrects the scaling binary (Address 0 and 1) and sensor binary (Address 2 and 3) of the current position value to the preset value set in advance.  
An example of the current position 'PRESET' function is shown below.

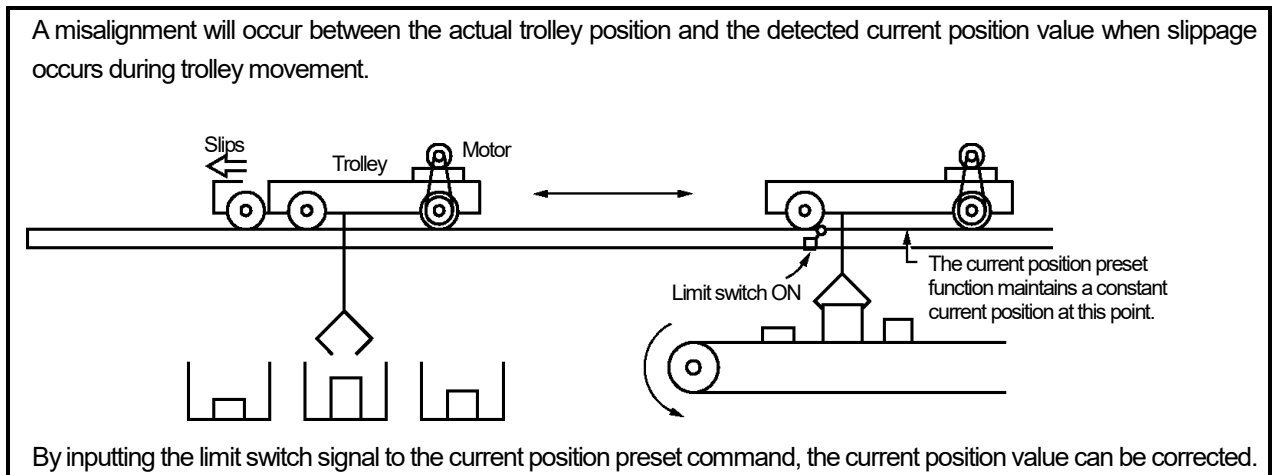

### ● Current position preset format

The following three formats are available for the current position preset function.  
The format can be selected at the current position preset function (Address 748).

Formats	Parameter format	Buffer memory format	Sequence format
Setting value of address 748	1	2	3
Input destination of preset signals *1	External I/O connector pin Nos. 9, 10 *2	External I/O connector pin Nos. 9, 10 *2	Device 17
Number of preset data	4 data which is set to the parameter area (Address 740 to 747) *3	2 data which is set to the RAM area (Address 690 to 693)	1 data which is set to the RAM area (Address 690 and 691)
Determination method of preset data used	Determined by the direction of variation in current position and actual input of two external inputs. *4	Determined by actual input of two external inputs.	RAM area (Address 690 and 691) only

\*1: The current position preset input operates at the leading edge.

\*2: The current position preset input has two channels and operates independently.

\*3: For the parameter format, two preset values can be designated; one for the FWD (forward) direction and the other for the RVS (reverse) direction.

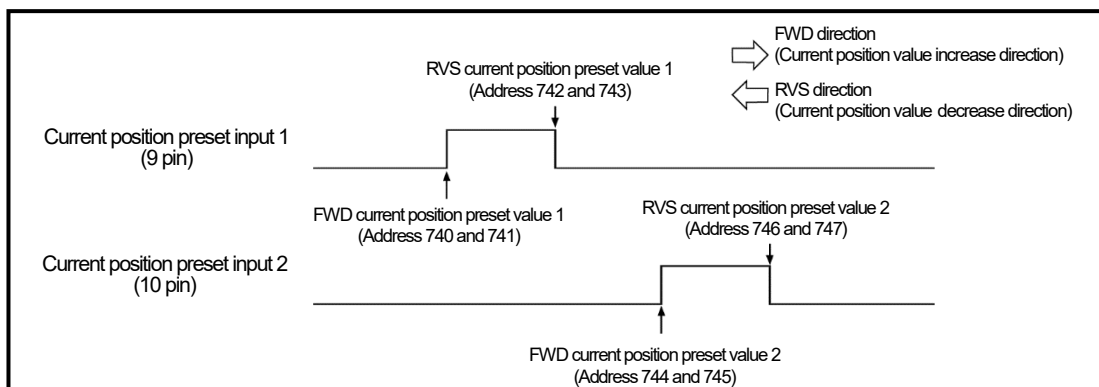

\*4: For the parameter format, the automatic travel direction determination by VS-QA62 is made by successively comparing the current position values at a 100ms interval. However, when the reverse speed is below the levels shown in the following table, VS-QA62 will determine that the current travel is in the forward direction.

Sensor model	Speed(r/min)
MRE-32SP	0.44
MRE-G64	0.88
MRE-G128	1.76
MRE-G160	2.20
MRE-G256	3.52
MRE-G320	4.40

### IMPORTANT

When the current position preset function is executed during a positioning operation, and when the resultant positioning will be in the reverse direction, the motion will be stopped momentarily and then automatically restarted.

The current position value might not be changed to the same value as the preset value when the scale length setting value exceeds the 'total number of divisions (131072)'.

### 6.6.1 The current position preset function (Address 748) setting

The 'format' should be selected from the following parameter when using the current position 'PRESET' function. For the parameter setting procedures, refer to 'Chapter 5.3'.

Address	Item	Contents	Setting range	Default
748	Current position preset function	Select the current position preset function format.	0: Disabled 1: Parameter format 2: Buffer memory format 3: Sequence format	0

## 6.6.2 The current position preset value setting

## ● Parameter format

The current position preset value has the following four types of parameters.  
For the parameter setting procedures, refer to 'Chapter 5.3'.

Address	Item	Contents	Setting range	Default
740(L) 741(H)	FWD current position preset value 1	The current position value is changed to a value designated at this parameter when the current position preset input 1 is turned ON while the machine travels in the FWD direction.	Minimum current position value to [minimum current position value + scale length -1]	0
742(L) 743(H)	RVS current position preset value 1	The current position value is changed to a value designated at this parameter when the current position preset input 1 is turned ON while the machine travels in the RVS direction.	Minimum current position value to [minimum current position value + scale length -1]	0
744(L) 745(H)	FWD current position preset value 2	The current position value is changed to a value designated at this parameter when the current position preset input 2 is turned ON while the machine travels in the FWD direction.	Minimum current position value to [minimum current position value + scale length -1]	0
746(L) 747(H)	RVS current position preset value 2	The current position value is changed to a value designated at this parameter when the current position preset input 2 is turned ON while the machine travels in the RVS direction.	Minimum current position value to [minimum current position value + scale length -1]	0

## ● Buffer memory format and sequence format

The current position preset value is designated in the following area of the buffer memory.

The setting value is returned to default when the following operation is done because this area isn't backed up.

- Reset PLC CPU.
- Turn OFF the PLC power supply.

This area can work just by writing the data in the buffer memory by TO instruction.

For the detailed timing, refer to 'Chapter 6.6.4 (9)'.

Address	Item	Contents	Setting range	Default
690(L) 691(H)	Current position preset value 1	This is a preset value for the buffer memory or sequence format. The current position value is changed to a value designated at this parameter when the current position preset input 1 or device Y17 is turned ON.	Minimum current position value to [minimum current position value + scale length -1]	0
692(L) 693(H)	Current position preset value 2	This is a preset value for the buffer memory format. The current position value is changed to a value designated at this parameter when the current position preset input 2.	Minimum current position value to [minimum current position value + scale length -1]	0

**IMPORTANT**

**In the case of changing the scale length or current position minimum value after setting the current position preset value**

The setting value isn't changed as is even though the preset value is out of the detection range.  
In this status, the current position preset has not executed because 'error 50' will occur.

### 6.6.3 'Excessive correction amount' detection

The 'Excessive correction amount' detection function monitors whether the change amount of the current position value that is corrected by inputting the current position preset signal is too large or not.

The following warning occurs when this correction amount exceeds the 'Permissible correction amount' (Address 738 and 739) of parameter;

- Device X5 ('Excessive correction amount' detection) is turned ON.
- Error 23 occurs.

However, the correction of the current position value is executed even if a warning occurs.

The permissible correction amount is designated in the following parameter.

For the parameter setting procedures, refer to 'Chapter 5.3'.

Address	Item	Contents	Setting range	Default
738(L) 739(H)	Permissible correction amount	Designate the permissible correction amount when presetting the current position value.	0 to 999999	999999

#### ● Clearing method of the warning

Turn ON (leading edge) Device Y16 (error reset).



## 6.6.4 Operation condition of the current position 'PRESET' function

- (1) The current position preset function is valid at the parameter setting.

Address	Item	Setting value	Contents
748	Current position preset function	1	Parameter format
		2	Buffer memory format
		3	Sequence format

- (2) No sensor error (Error code 22)
- (3) The status must be online.  
Turn ON Y10 by the sequence program.  
Device X1 is turned ON and the status is online.
- (4) Don't turn ON the current position preset prohibit signal (Y17 and Y18).  
'Current position preset input 1' of the external I/O connector is invalid when Y17 is turned ON.  
'Current position preset input 2' of the external I/O connector is invalid when Y18 is turned ON.  
Y17 operates as 'current position preset command' (leading edge) when selecting the sequence format.
- (5) The current position preset won't be executed if the current position preset input is already ON when turning ON the power supply.
- (6) The current position preset input 1 is taken on priority when turning ON the current position preset input 1 and 2 simultaneously. The current position preset 2 won't be accepted.
- (7) Turn ON the current position preset input more than 100ms.  
In addition, 100ms or more OFF time is needed until accepting the next current position preset input.

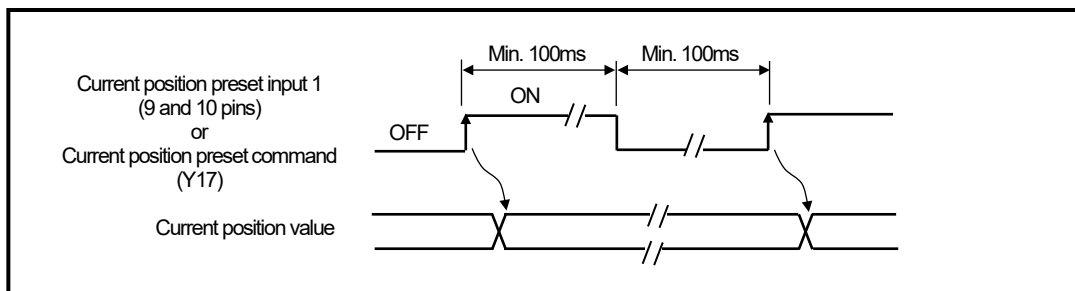

(8) Response time of the current position preset input

This indicates the response time from turning ON the current position preset input to executing the preset. The response time of the current position preset is varied depending on the setting of the current position preset function (Address 748).

① Parameter format: 1, buffer memory format: 2 (Max. 5ms)

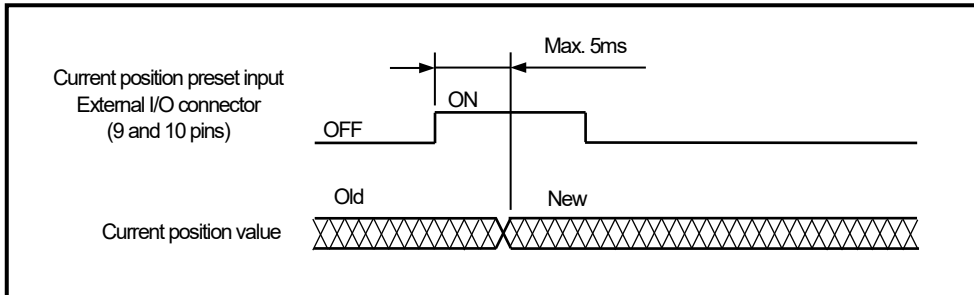

② Sequence format: 3 (Max. 2ms)

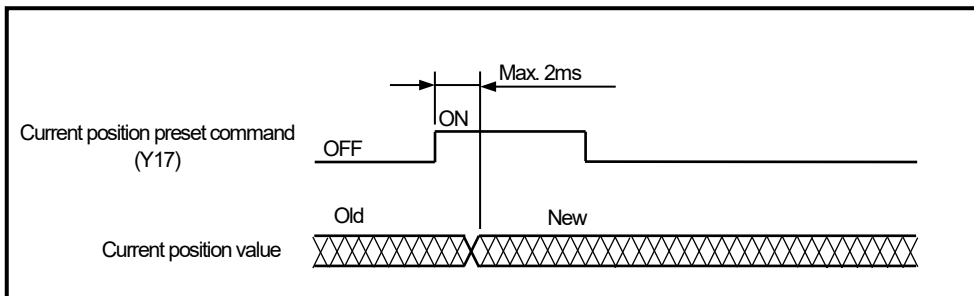

(9) Effective time of the current position preset input and current position preset command

In the buffer memory or sequence format, this indicates the time the current position preset input (command) becomes enabled after writing a preset value to the buffer memory by TO instruction. The setting value might change to the previous one if the current position preset input (command) is turned ON during this time.

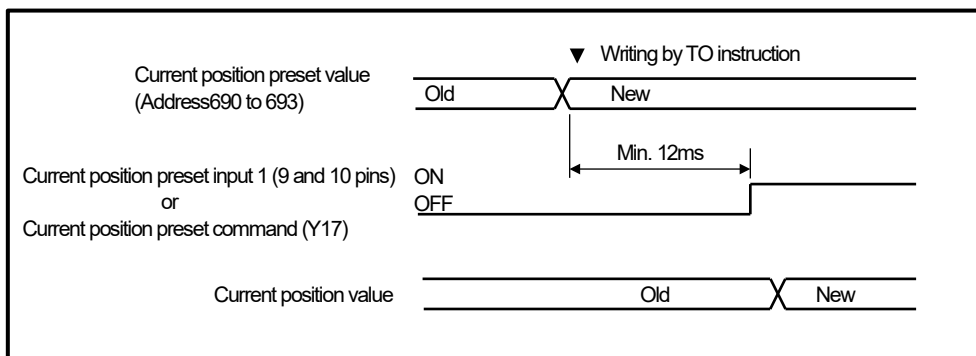

### 6.6.5 Input status storage area (Address 6)

This area stores the current position preset input signal status of the external I/O connector.  
'1' is stored when the current position preset input is turned ON.

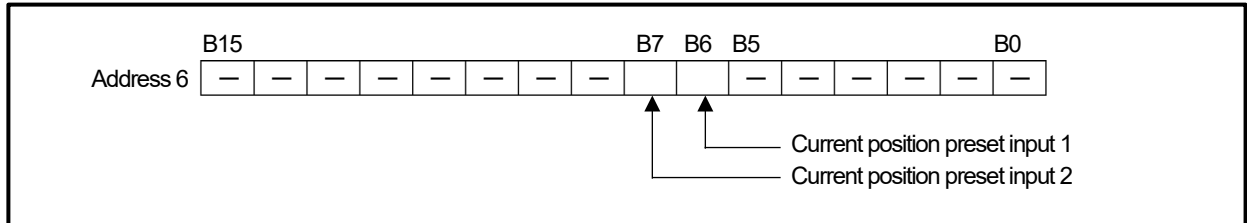

### 6.7 Current Position HOLD Function

The current position HOLD function is that stores the current position value in the below areas when the current position preset input 1 or 2 of the external I/O connector is turned ON (leading edge).

Address	Contents
670(L) 671(H)	Hold current position (scaling binary)
672(L) 673(H)	Hold current position (sensor binary)

When the 'current position preset' function is active, the current position value before preset is stored.

Below are operation examples when the 'current position preset' signal turned ON.

Current position preset function (Setting value of address 748)	Current position value before HOLD	Preset value	Current position HOLD		Current position preset	
			Operation	Hold current position	Operation	Preset current position
0 (Disabled)	300	100	Held	300	Invalid	300
1 (Parameter format)	300	100	Held	300	Valid	100
2 (Buffer memory format)	300	100	Held	300	Valid	100
3 (Sequence format)	300	100	Held	300	Invalid	300

#### Point

- (1) The current position preset input of the external I / O connector is used for both the current position preset function and the current position HOLD function.
- (2) The current position HOLD function is active when either the current position preset input 1 or 2 is turned ON.
- (3) The current position HOLD function is active while power is ON.

## 6.8 Speed Detection Function

The speed detection function is that the rotation (travel) speed of the ABSOCODER sensor is output.

The speed unit is selected at a speed gate time (Address 749) of the buffer memory.

The speed is stored in the speed output (Address 668 and 669) of the buffer memory.

Also, the speed can be output as analog voltage from the external I/O connector (13 and 26 pins).

For more details of the analog voltage output, refer to 'Chapter 6.9'.

### 6.8.1 Parameter setting

The speed detection function is set in the parameter in the second row in the below chart.

For the details about setting contents, refer to 'Chapter 6.8.2'.

For the parameter setting procedures, refer to 'Chapter 5.3'.

Address	Item	Contents	Setting range	Default
749	Speed gate time	Select the speed gate time for detecting the sensor binary value change amount (0 to 6) Also, selects the rotation and traveling speeds.	0: 0.8ms 1: 1.6ms 2: 3.2ms 3: 6.4ms 4: 12.8ms 5: 25.6ms 6: 51.2ms 7: Rotation speed (r/min) 8: Travel speed (scale value/s) *1	0
750	Speed sampling time	Select the speed sampling time. However, this parameter is invalid when selecting '7' or '8' in Address 749.	0: Same as speed gate time 1: 1/2 of speed gate time 2: 1/4 of speed gate time	0

\*1: A unit of the 'scale value' is decided depending on the setting of the scale length of the initial setting.

The unit of travel speed is mm/s if the scale length is set mm unit.



### (2) Rotation speed (setting value of Address 749: 7)

The rotation speed (r/min) of the ABSOCODER sensor is stored by each 117.2ms.

The speed is calculated by average speed within 234.4ms.

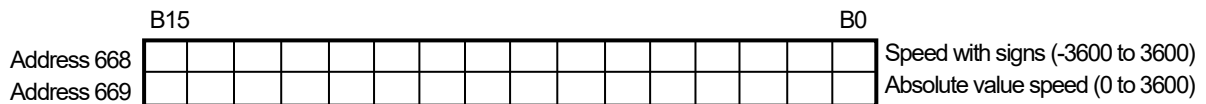

**Point**

- With the speed with signs, the rotation direction designated at the sensor rotation direction (Address 702) is stored as 'positive (+)'.  
 'Negative (-)' rotation speed is stored as a complement of '2'.
- When using the MRE-G [ ] type ABSOCODER sensor, the rotation speed to be stored is 1/gear ratio ([ ]/32). [ ]: total number of turns

### (3) Travel speed (setting value of Address 749: 8)

The travel speed (scale value/s) which is calculated based on the change amount of the current position value (scaling binary) is stored by each 200ms.

The speed is calculated by average speed within 1000ms.

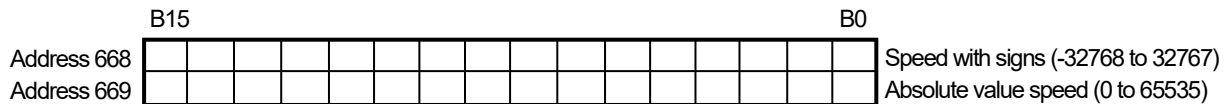

**Point**

- With the speed with signs, the rotation direction designated at the sensor rotation direction (Address 702) is stored as 'positive (+)'.  
 'Negative (-)' rotation speed is stored as a complement of '2'.
- The upper value (or lower value) is stored when the speed exceeds the output range.

### 6.9 Analog Voltage Output Function (Position/Speed)

The analog voltage output function is that the position or speed is output as the voltage from the external I/O connector (13 and 26 pins).

The output voltage range can be designated to the desired value (max±10V).

#### 6.9.1 Parameter setting

Specify the following 5 items at parameters.

For the parameter setting procedures, refer to 'Chapter 5.3'.

Address	Item	Contents	Setting range	Default
751	Analog output data selection	Select the analog output data.	0: No output (Fixed at 0) 1: Absolute value speed command (0 to 100%) 2: Speed command (-100 to 100%) 3: Current speed *1 4: Current position (scale value) *2	0
752(L) 753(H)	Maximum output voltage (Vmax)	Designate the analog output maximum voltage.	Vmin to 10.00 [V]	1000
754(L) 755(H)	Minimum output voltage (Vmin)	Designate the analog output minimum voltage.	-10.00 to Vmax [V]	0
756(L) 757(H)	Maximum output value	Designate the value for outputting maximum voltage.	-999999 to 999999	100
758(L) 759(H)	Minimum output value	Designate the value for outputting minimum voltage.	-999999 to 999999	0

\*1: The unit of "Current speed" is decided by the selecting value of the parameter's "speed gate time" (Address 749).  
For more details, refer to "Chapter 6.8.2".

\*2: A unit of the 'scale value' is decided depending on the setting of the scale length of the initial setting.  
The unit of current position is mm if the scale length is set mm unit.



● Details of the parameter

① Selection of the analog output data (Address 751)

Select output contents of the analog voltage.

0: No output

The output is fixed at 0.

1: Absolute value speed command

The speed command is output 0 to 100%.

2: Speed command

The speed command is output -100 to 100%.

**Point**

Select '3 or 4' when position or speed is output.

3: Current speed

The speed is output in a unit that is selected at the speed gate time (Address 749) of the parameter.

Refer to 'chapter 6.8.1'

4: Current position (scale value)

The current position value (scaling binary) is output.

② Maximum output voltage (V max) (Address 752 and 753)

Designate the maximum value of the output voltage.

Setting range: V min to +10.00V

The voltage becomes this value when the output voltage exceeds the maximum output voltage.

③ Minimum output voltage (V min) (Address 754 and 755)

Designate the minimum value of the output voltage.

Setting range: -10.00V to V max

The voltage becomes this value when the output voltage is less than the minimum output voltage.

④ Maximum output value (Address 756 and 757)

Designate the 'value' for outputting the maximum voltage.

The unit of the value is varied depending on the data selected at Address 751.

The maximum voltage is output when the value selected at Address 751 reaches this setting value. Refer to 'chapter 6.9.2'

Setting range: -999999 to 999999

⑤ Minimum output value (Address 758 and 759)

Designate the 'value' for outputting the minimum voltage.

The unit of the value is varied depending on the data selected at Address 751.

The minimum voltage is output when the value selected at Address 751 reaches this setting value. Refer to 'chapter 6.9.2'

Setting value: -999999 to 999999

## 6.9.2 Setting example

● When [Minimum output Value] < [Maximum output Value]

Output from -8.00V to +8.00V at from Point A to Point B

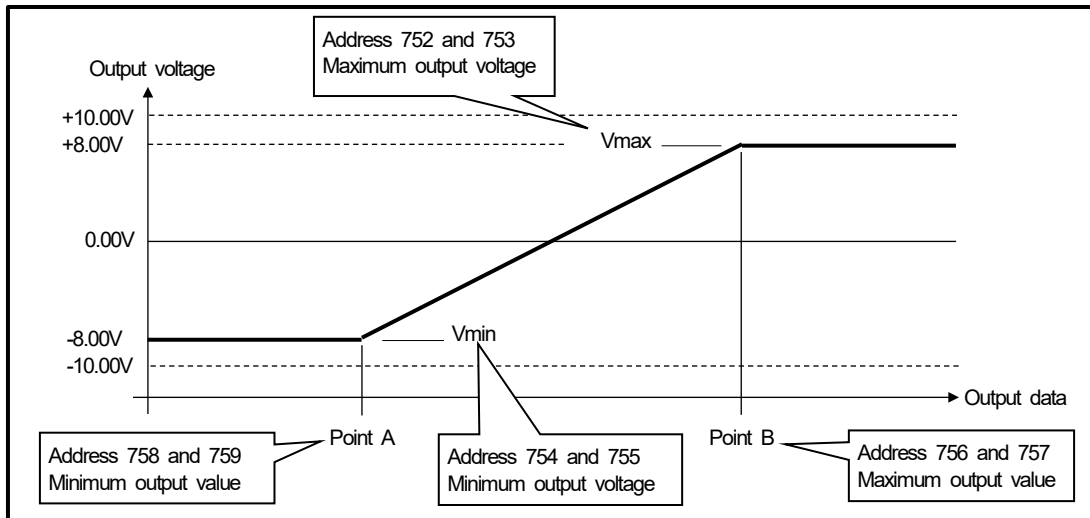

● When [Minimum output value] > [Maximum output value]

Output from +8.00V to -8.00V at from Point C to Point D

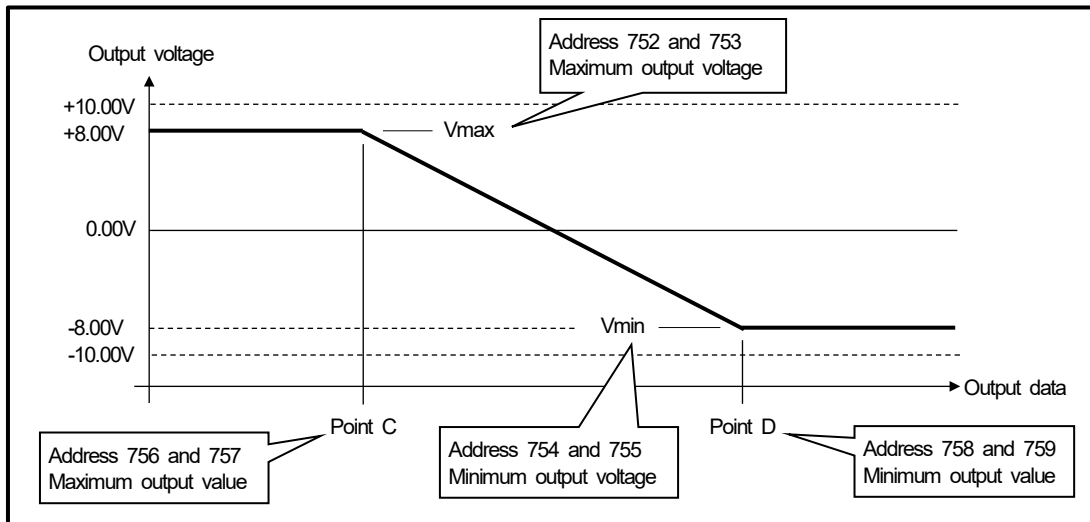

**IMPORTANT**

Note that the output voltage will change at once when the 'minimum output value' or the 'maximum output value' is specified to outside of the detection range after setting '4: current position' to the analog output data selection of the parameter (Address 751).

Remember to designate those values within the detection range.

Example of output from -8.00V to +8.00V at from Point A to Point B

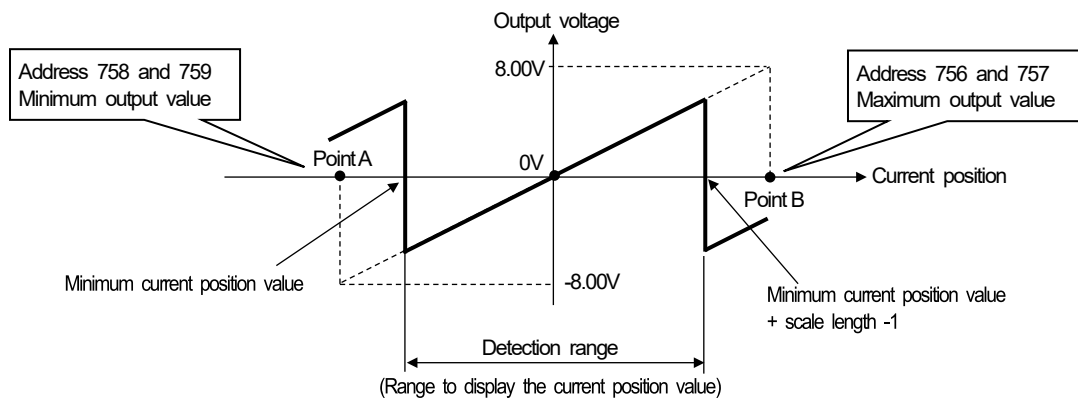

## 7. LIMIT SWITCH OUTPUT FUNCTION

### ● Limit switch output

The limit switch output function operates as same as the mechanical limit switch.

Positions that the mechanical limit switch turns ON or OFF are set to VS-QA62 in advance.

VS-QA62 turns the limit switch output signal ON or OFF by comparing the machine position detected by the ABSOCODER sensor and setting value.

The number of output points is a maximum of 16 points (0 to 15 channels).

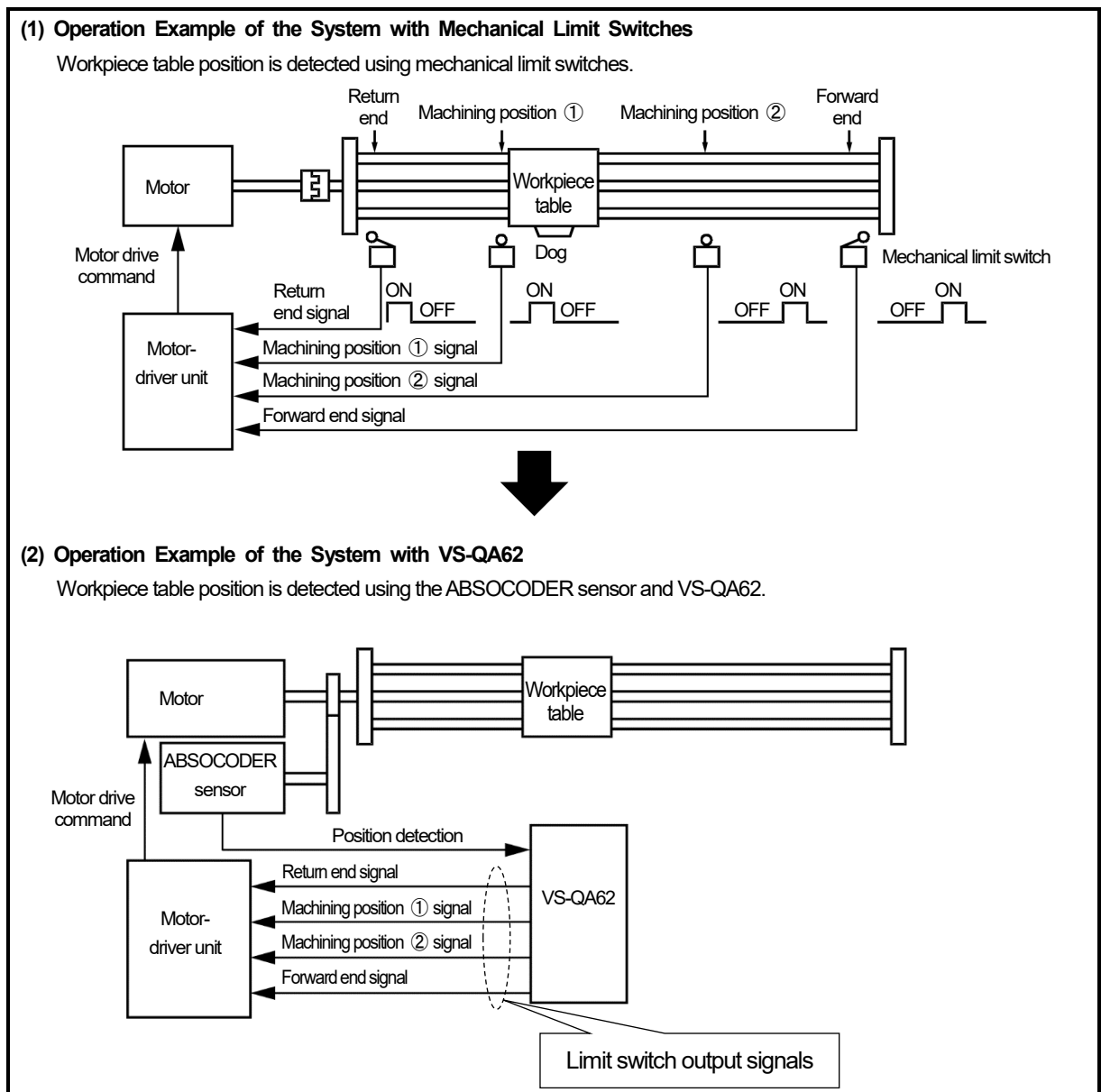

### ● Multi-Dog function

The combination of ON and OFF positions of the limit switch output is called "dog".

The limit output switch output can set up to five ON and OFF positions (Dogs) for each channel.

This is called "multi-dog".

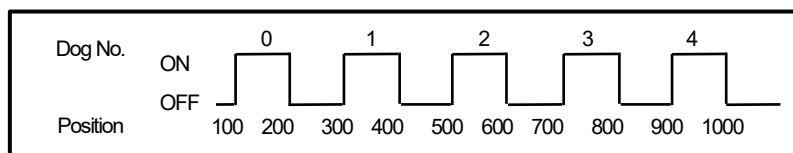

## 7.1 Setting Contents of the Limit Switch Output Data

The limit switch output sets the following combination data for each channel.

- Number of multi-dogs
- ON / OFF position for each dog

For the setting procedures, refer to 'Chapter 5.4'.

IMPORTANT	<ul style="list-style-type: none"> <li>- The setting value of the limit switch cannot be read out.</li> <li>- '0' is written for the limit switch data when the power supply turns ON.</li> </ul> <p style="margin-left: 20px;">The data is not backed up, so manage it with the host controller's program.</p>
-----------	---

### (1) Setting numbers of the multi-dog

Setting range: 1 to 5

The channel's output doesn't operate when setting '0'.

A number of the multi-dog becomes '5' when setting a number more than 6.

### (2) ON/OFF position setting

Setting range: within detection range (minimum current position value to (minimum current position value + scale length -1))

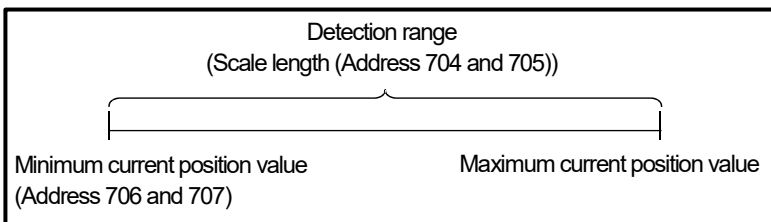

An error occurs in the following cases;

- The setting value exceeds of the detection range.
- In the multi-dog setting, the setting values of adjacent dogs overlapped.

### (3) Setting of a-contact (ON position < OFF position) or b-contact (OFF position < ON position)

a-contact and b-contact cannot be combined when setting the multi-dog.

Designate values at a-contact to all the subsequent dogs when setting the first dog (dog 0) as a-contact.

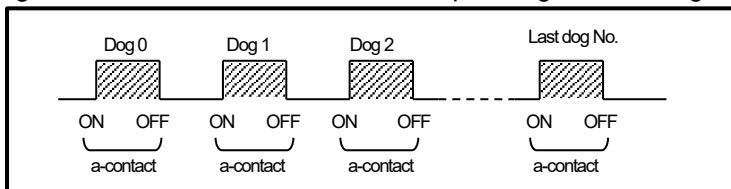

Designate values at b-contact to all the subsequent dogs when setting the first dog (dog 0) as b-contact.

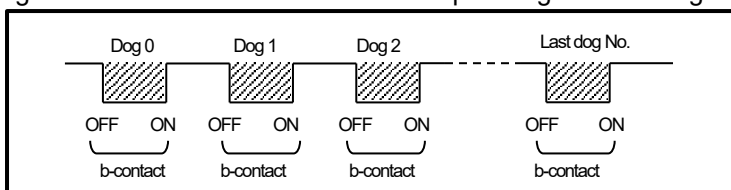

## (4) Setting example

### ① In the case of a-contact (ON position < OFF position)

The value of the ON position should be designated less than the OFF position, and set as pair.  
 Each dog should be written in ascending order; otherwise, an error occurs.  
 (The value of the dog '0' should be less than dog '1'.)

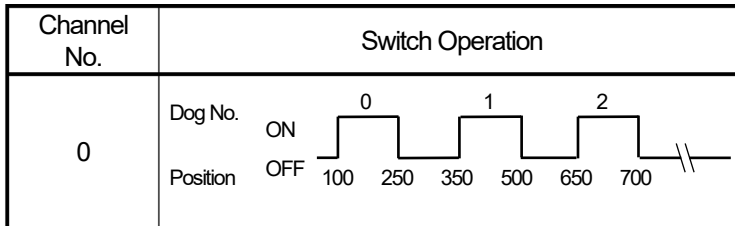

Address (decimal)	Value	Description
14	3	Number of CH. 0 multi-dogs
15	0	
16	100	ON position of the dog '0'
17	0	
18	250	OFF position of the dog '0'
19	0	
20	350	ON position of the dog '1'
21	0	
22	500	OFF position of the dog '1'
23	0	
24	650	ON position of the dog '2'
25	0	
26	700	OFF position of the dog '2'
27	0	
28		The number of the multi-dog is designated to '3', so the setting is invalid.
35		
36		

### ② In the case of b-contact (OFF position < ON position)

The value of the ON position should be designated larger than the OFF position, and set as pair.  
 Each dog should be written in ascending order; otherwise, an error occurs.  
 (The value of the dog '0' should be less than dog '1'.)

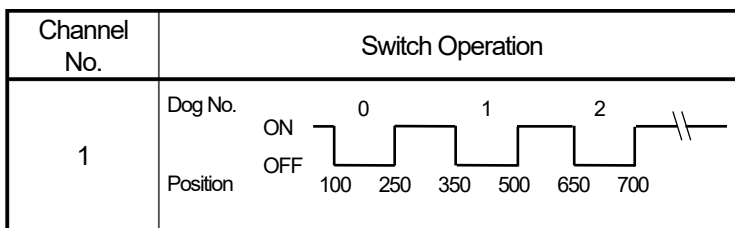

Address (decimal)	Value	Description
36	3	Number of CH. 0 multi-dogs
37	0	
38	250	ON position of the dog '0'
39	0	
40	100	OFF position of the dog '0'
41	0	
42	500	ON position of the dog '1'
43	0	
44	350	OFF position of the dog '1'
45	0	
46	700	ON position of the dog '2'
47	0	
48	650	OFF position of the dog '2'
49	0	
50		The number of the multi-dog is designated to '3', so the setting is invalid.
57		
58		

## 7.1.1 Setting conditions of the ON and OFF zones

The minimum setting width of the ON/OFF zone is determined by the sampling time of the current position value.

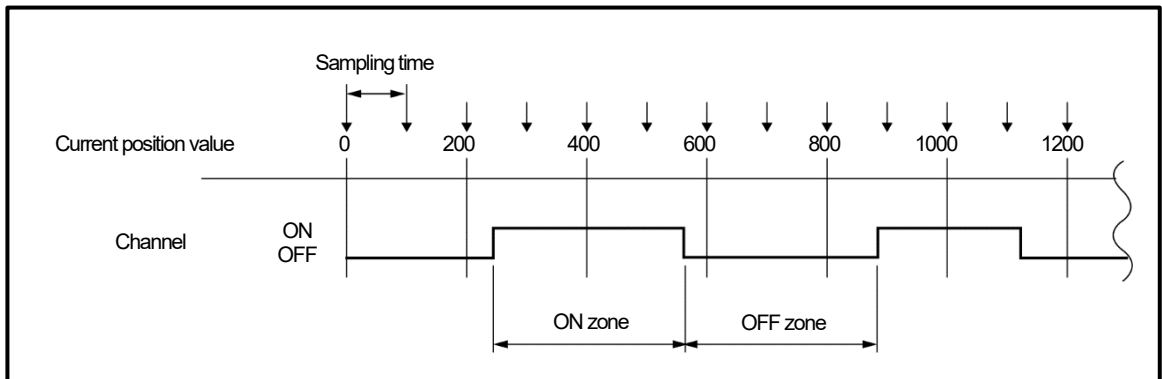

The limit switch output function samples the current position value data every 0.4ms and outputs the limit switch signal as compared with the ON/OFF data set.

When the machine travels by exceeding a given permissible speed, position detection at each minimum setting unit of the scale length will become impossible, and the outputs of ON and OFF signals as designated will also be impossible.

Consider the followings for this case;

- Set wider between ON and OFF zone.
- Decrease the operation speed less than permissible speed.

The permissible speed is calculated by the following formula.

$$\text{Permissible speed} = \frac{\text{Minimum setting unit of the scale length}}{\text{Sampling time}} \times \frac{\text{Setting width}}{\text{Minimum setting unit of the scale length}}$$

### Example

In the case of the minimum setting unit of the scale length is 0.01mm and the setting width is 0.1mm,

$$\begin{aligned} \text{Permissible speed} &= \frac{0.01\text{mm}}{0.4\text{ms}} \times \frac{0.1\text{mm}}{0.01\text{mm}} \\ &= \frac{0.1\text{mm}}{0.4\text{ms}} \times 1000 \\ &= 250\text{mm/s} \end{aligned}$$

## 7.2. Parameter for Related to the Limit Switch Output

The parameters related to the limit switch output are indicated below.

They should be set for each function and set them when you need.

For more detailed functions, see the reference chapter.

For the parameter setting procedures, refer to 'Chapter 5.3'.

● **Parameter list**

1/1

Address	Item	Contents	Setting range	Default	Reference (Chapter No.)
711	Output signal selection	Select the signal contents which are output to the external I/O connector (1 to 8) and device (X8 to XF).	0: Positioning output 1: Limit switch output 2: Current position detection (No signal output)	2	7.3
733	Offline channel output status	Designate the limit switch output status when offline.	0: All-points OFF 1: Hold	0	7.4



## 7.3 Output Signal Selection Function

The output signal selection function is that selects the contents of the following output signals.

- External I/O connector (1 to 8 pins)
- Device X8 to XF

The contents of the output signal can be selected in the following parameter.

For the parameter setting procedures, refer to 'Chapter 5.3'.

Address	Item	Contents	Setting range	Default
711	Output signal selection	Select the signal contents which are output to the external I/O connector (1 to 8 pins) and device (X8 to XF).	0: Positioning output 1: Limit switch output 2: Current position detection (No signal output)	2

### ● Setting contents

- 0: Positioning output  
8 points of output are used as the positioning signal.
- 1: Limit switch output  
8 points of output are used as the limit switch output signal.
- 2: Current position detection  
8 points of output aren't output anything. (not used)

### ● Pin number (device No.) of the external I/O connector and output contents

Setting value Pin No. (device No.)	2 (Current position detection)	1 (Limit switch output)	0 (Positioning)		
			Speed switching format	Speed stepping format	Acceleration /Deceleration format
1 (X8)	Not used	CH.0	FWD	FWD/low-speed	FWD
2 (X9)	Not used	CH.1	RVS	RVS/low-speed	RVS
3 (XA)	Not used	CH.2	High-speed	High-speed	Not used
4 (XB)	Not used	CH.3	Low-speed	Medium-speed	Not used
5 (XC)	Not used	CH.4	Brake release		
6 (XD)	Not used	CH.5	In-position		
7 (XE)	Not used	CH.6	Positioning in progress		
8 (XF)	Not used	CH.7	Operation error		

#### IMPORTANT

#### Using the limit switch output and positioning functions together

The limit switch and positioning outputs are also stored in the following buffer memory.

- Limit switch output status (Address 4)
- Positioning output status (Address 696)

Use the buffer memory for either of the outputs if both functions are used.

#### 7.4 Offline Channel Output Status Setting

The limit switch output status when offline can be selected.  
 The output status can be selected in the following parameter.  
 For the parameter setting procedures, refer to 'Chapter 5.3'.

Address	Item	Contents	Setting range	Default
733	Offline channel output status	Designate the limit switch output status when offline.	0: All-points OFF 1: Hold	0

##### ● Setting contents

###### 0: All-points OFF

The limit switch output is turned OFF for all channels when switching to offline.

###### 1: Output HOLD

ON/OFF status of the limit switch output just before switching offline can be held.

However, the limit switch output is turned OFF for all channels when the following operation is done.

- In the case of turning ON the power supply again
- In the case of resetting the PLC CPU

## 7.5 Limit Switch Output Disabled Function

This function designates for each channel whether or not limit switch output is executed.  
 The limit switch output disabled setting is designated the following area of the buffer memory.

Address	Item	Contents	Setting range	Default
8	Limit switch output disabled setting	Designate for each channel whether or not limit switch output is executed.	0: Enabled 1: Disabled	0

This area can be designated just by writing the data to the buffer memory by the TO instruction.  
 The data can be written when online or offline, but it operates only online.

● **Setting contents**

- 0: enabled
- 1: disabled

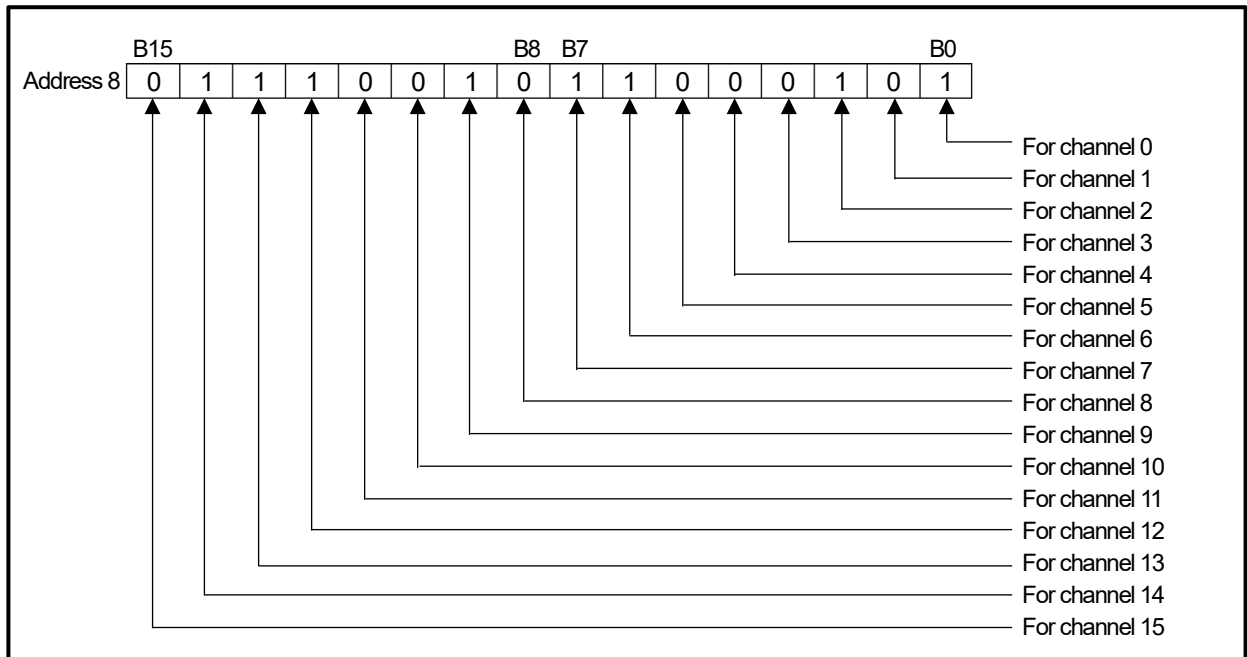

**IMPORTANT**

All channels are designated to the default value '0: enabled' when the following operation is done.

- In the case of turning ON the power supply again
- In the case of resetting the PLC CPU

The limit switch output isn't executed when device Y10 (PLC ready) or Y15 (limit switch output enabled) is turned OFF even if channels are designated to '0: enabled'.

## 7.6 Limit Switch Output Selection when Positioning Function

The limit switch output selection when positioning is that switches signal contents which are output to the external I/O connector (6 to 8 pins) from positioning to outputting the limit switch. It is set in the following area of the buffer memory.

Address	Item	Contents	Setting range	Default
12	Limit switch output selection when positioning	Switch signal contents which are output to the external I/O connector (6 to 8 pins) from positioning to outputting the limit switch.	0: Positioning output 1: Limit switch output	0

This area can be designated just by writing the data to the buffer memory by the TO instruction. The data can be written when online or offline.

### ● Setting contents

- 0: Positioning output
- 1: Limit switch output

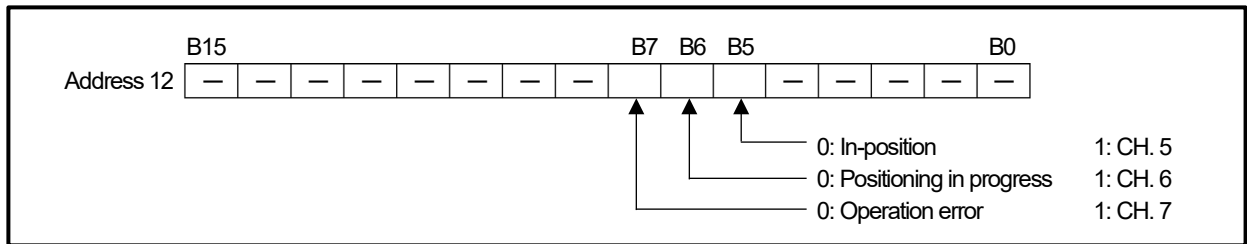

### ● Pin number of the external I/O connector and output contents

Pin No.	Setting value	
	1 (Limit switch output)	0 (Positioning output)
6	CH. 5	In-position
7	CH. 6	Positioning in progress
8	CH. 7	Operation error

## 7.7 Limit Switch Output Operation

### 7.7.1 Procedures before the operation

The procedures and timing chart for executing the limit switch output are indicated below.

● Procedure

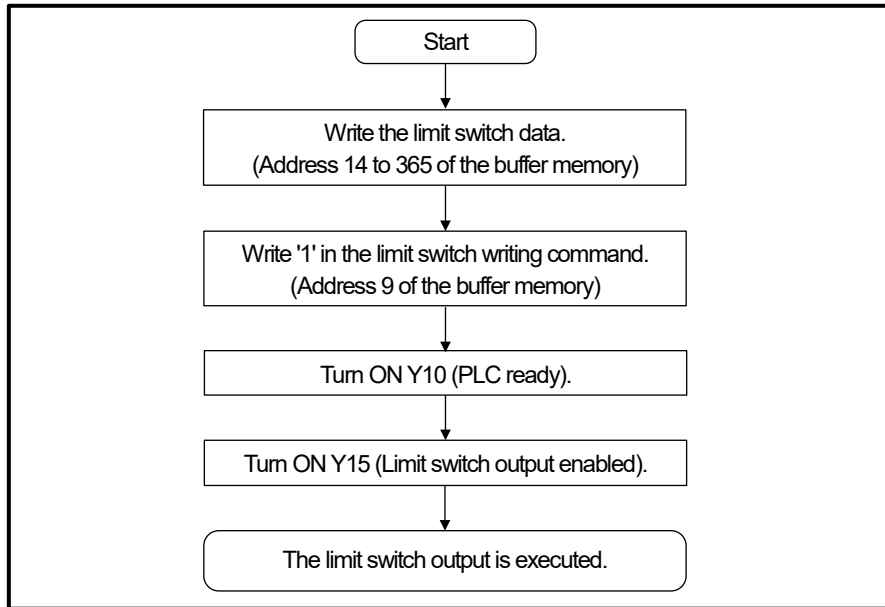

● Timing chart

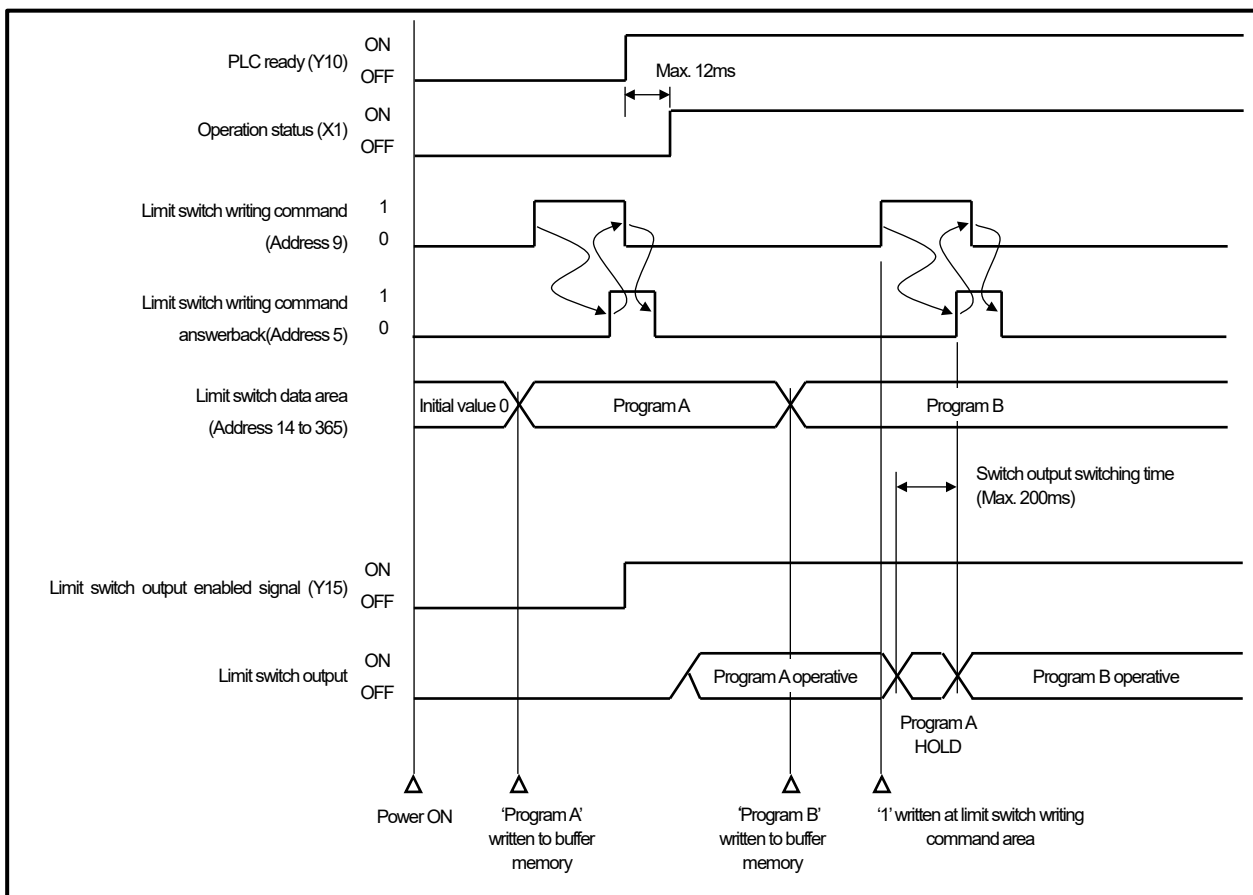

## 7.7.2 'Limit switch output status' storage area (Address 4)

This area is used to store the limit switch output status (ON/OFF status).

During the operation, each channel status based on the limit switch output data is output to the bit indicated in the following figure.

'1' is stored when the limit switch output is ON.

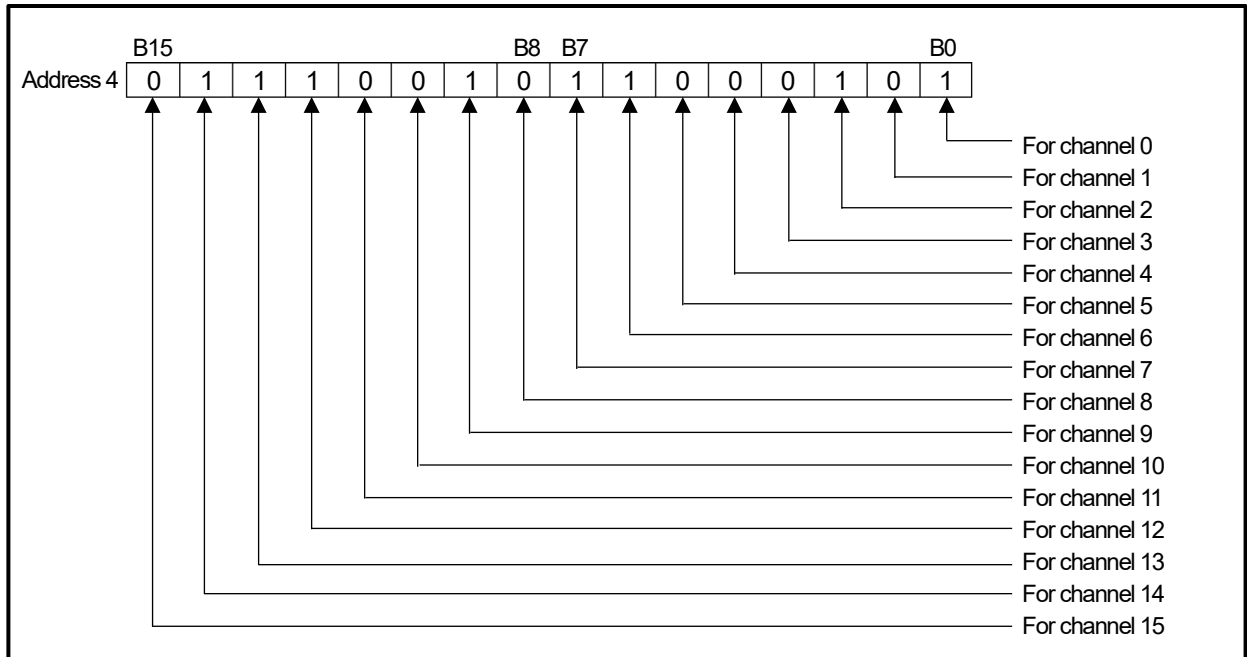



## 8. POSITIONING FUNCTION (2-SPEED/3-SPEED CONTROL)

The positioning function is that stops the machine to the designated position.

The parameters, the positioning pattern data and the target value (stop position) are set to VS-QA62 in advance.

VS-QA62 outputs the motor control signal by comparing the current position value detected by the ABSOCODER sensor and setting value.

This chapter explains the speed switching format (2-speed control) and speed stepping format (3-speed control).

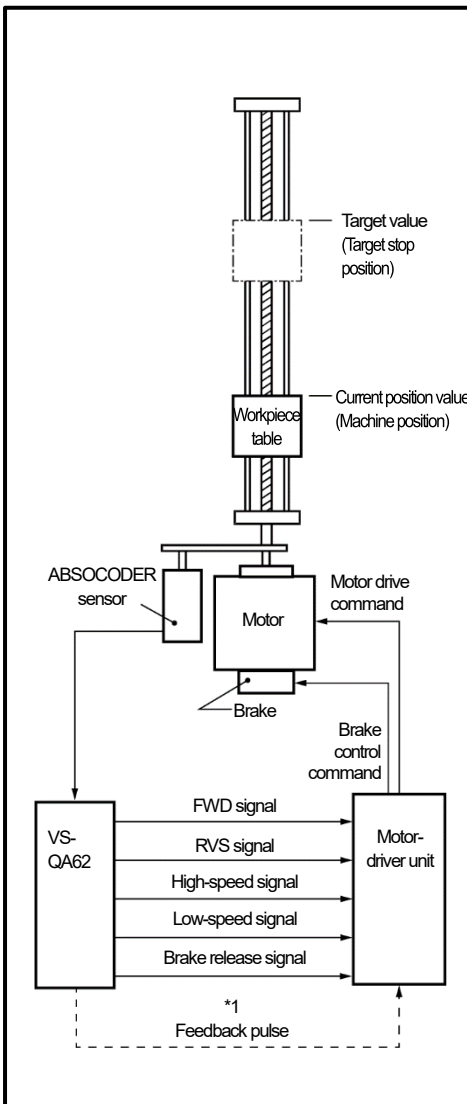

\*1: Positioning responsiveness can be improved by inputting the pulse output of the current position detection function to the vector control inverter.

(Note)

The performance might not achieve well if the number of pulses per motor revolution is small.

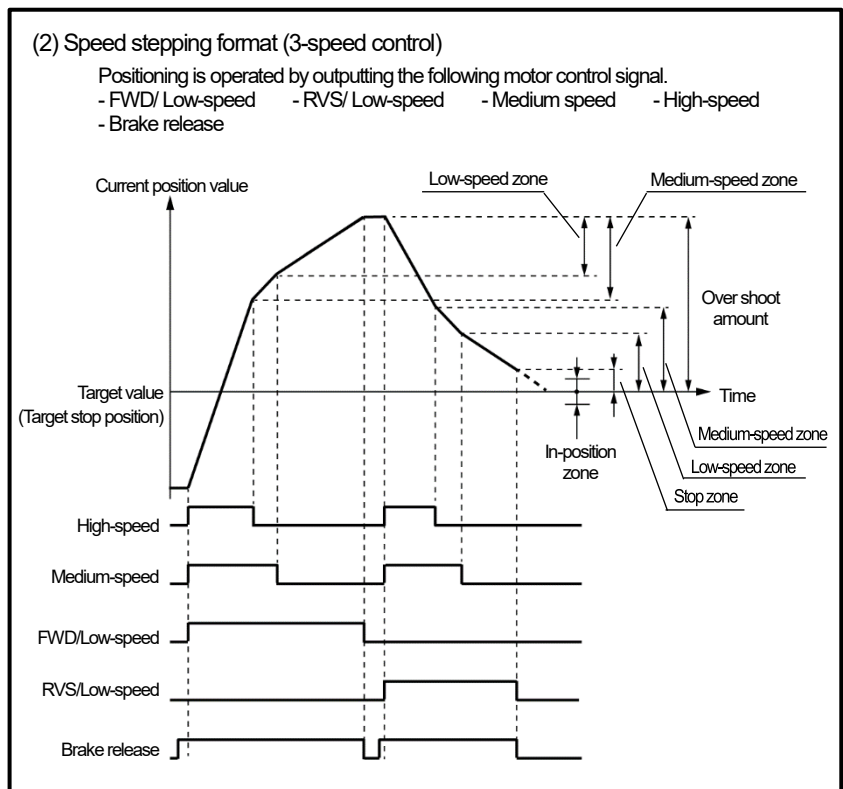
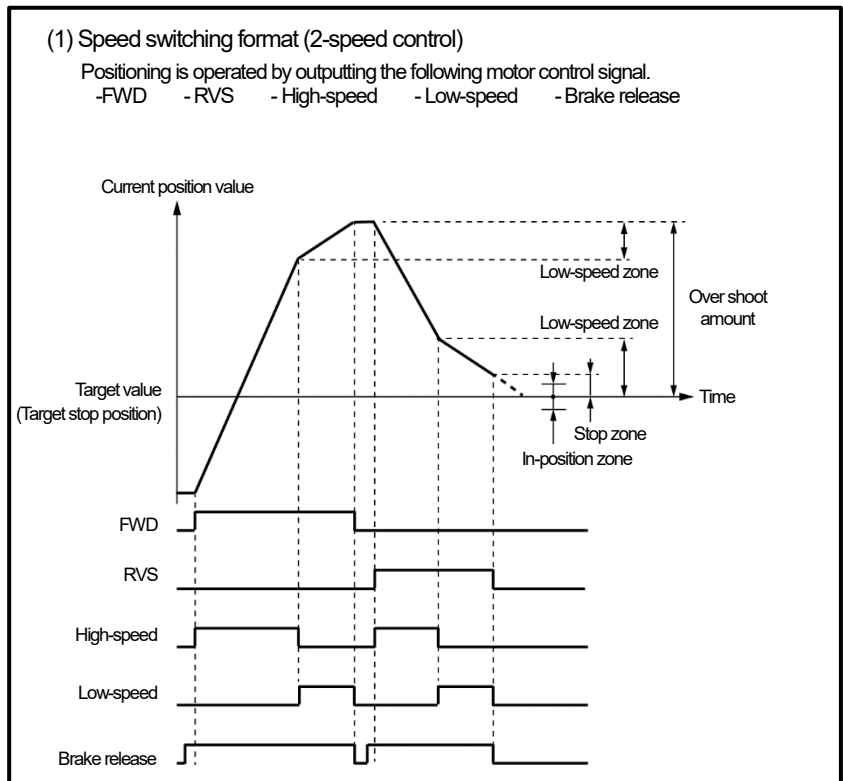



## 8. POSITIONING FUNCTION (2-SPEED/3-SPEED CONTROL)

MELSEC-Q

### 8.1 Parameter for Related to the Positioning

The parameters related to the positioning are indicated below.

They should be set for each function and set them when you need.

For more detailed functions, see the reference chapter.

For the parameter setting procedures, refer to 'Chapter 5.3'.

#### ● Parameter list

1/1

Address	Item	Contents	Setting range	Default	Reference (Chapter No.)
711	Output signal selection	Select the signal contents which are output to the external I/O connector (1 to 8) and device (X8 to XF).	0: Positioning output 1: Limit switch output 2: Current position detection (No signal output)	2	7.3
712	Positioning format	Select the positioning format.	0: Speed switching format (2-speed) without learning function 1: Speed stepping format (3-speed) without learning function 2: Speed switching format (2-speed) with learning function 3: Speed stepping format (3-speed) with learning function 4: Acceleration/Deceleration control format without learning function 5: Acceleration/Deceleration control format with learning function	0	8.2
713	Positioning direction	Select the positioning direction.	0: FWD direction 1: RVS direction	0	8.3
714(L) 715(H)	Overshoot amount	Designate the distance by which the target value is overshoot before a U-turn is made when executing the "unidirectional positioning".	0 to 999999	100	8.3
716(L) 717(H)	Medium-speed zone	Uses in the speed stepping format (3-speed control). Designate the distance from the target value at the position that is switched from high-speed to medium-speed.	0 to 999999	10000	8.4.2
718(L) 719(H)	Low-speed zone	Designate the distance from the target value at the position that is switched from high-speed or medium-speed to low-speed.	0 to 999999	1000	8.4.2
720(L) 721(H)	Stop zone	Designate the distance from the target value at the position that is applied to the brake.	0 to 999999	100	8.4.2
722(L) 723(H)	In-position zone	Designate a reference distance used to determine if the machine is stopped at the target value.	0 to 999999	100	8.4.2
724(L) 725(H)	Upper limit value (+limit)	Designate the '+' direction limit value.	-99999 to 999999	999999	8.5
726(L) 727(H)	Lower limit value (-limit)	Designate the '-' direction limit value.	-99999 to 999999	-99999	8.5
728	Start from stop zone	Designate whether the positioning is executed when the START position is already within the stop zone.	0: Disable 1: Enable	1	8.6
729	Motion non-detection timer	Designate the period from the point when positioning is started until the point when the 'motion detection check' starts.	0 to 9999 (Setting units: 10ms)	1000	8.9
730	Motion misdirection non-detection timer	Designate the period from the point when positioning is started until the point when the 'motion direction check' starts.	0 to 9999 (Setting units: 10ms)	1000	8.9
731	Positioning end detection timer	Designate the OFF delay period of the 'positioning in progress' signal upon completion of positioning.	0 to 9999 (Setting units: 10ms)	10	8.7.3
732	JOG low-speed timer	Designate the low-speed operation period for the JOG operation.	0 to 9999 When '9999', 'Low-Speed' is always specified. (Setting units: 10ms)	9999	8.8

## 8. POSITIONING FUNCTION (2-SPEED/3-SPEED CONTROL)

MELSEC-Q

### ● For positioning function (RAM area)

These are areas that store the positioning patterns.

1/1

Address	Item	Contents	Setting range	Default	Reference (Chapter No.)
680(L) 681(H)	Medium-speed zone	Uses in the speed stepping format (3-speed control). Designate the distance from the target value at the position that is switched from high-speed to medium-speed.	0 to 999999	Address 716	8.4.3
682(L) 683(H)	Low-speed zone	Designate the distance from the target value at the position that is switched from high-speed or medium-speed to low-speed.	0 to 999999	Address 718	8.4.3
684(L) 685(H)	FWD stop zone	Designate the distance from the target value at the position that is applied to the brake of the FWD direction.	0 to 999999	Address 720	8.4.3
686(L) 687(H)	RVS stop zone	Designate the distance from the target value at the position that is applied to the brake of the RVS direction.	0 to 999999	Address 720	8.4.3
688(L) 689(H)	In-position zone	Designate a reference distance used to determine if the machine is stopped at the target value.	0 to 999999	Address 722	8.4.3

#### Point

The positioning pattern data can be set in two parts (parameter area and RAM area).

Using area is selected by 'positioning pattern data buffer memory selection (Address 679)'.

### ● Speed limit (RAM area)

This is an area that limits the speed for the test run and etc..

1/1

Address	Item	Contents	Setting range	Default	Reference (Chapter No.)
678	Speed limit	Designate the limit speed.	1: Speed stepping format (3-speed) (low-speed) Speed switching format (2-speed) (low-speed)  2: Speed stepping format (3-speed) (medium-speed) Speed switching format (2-speed) (no limit)  3: Speed stepping format (3-speed) (no limit) Speed switching format (2-speed) (no limit)	3	8.4.4

### 8.2 Positioning Format and Simple Learning Function Selection

The positioning format is selected.

In addition, the simple learning function is selected to either valid or invalid.

The positioning format and simple learning function can be selected by the following parameter.

Address	Item	Contents	Setting range	Default
712	Positioning format	Select the positioning format.	0: Speed switching format (2-speed) without learning function 1: Speed stepping format (3-speed) without learning function 2: Speed switching format (2-speed) with learning function 3: Speed stepping format (3-speed) with learning function 4: Acceleration/Deceleration control format without learning function *1 5: Acceleration/Deceleration control format with learning function *1	0

\*1: For the acceleration/deceleration control format, refer to 'Chapter 9'.

For the details of the positioning format, refer to 'Chapter 8.2.1 and 8.2.2'.

For the details of the simple learning function, refer to 'Chapter 8.2.3'.

For the parameter setting procedures, refer to 'Chapter 5.3'.

## 8.2.1 Speed switching format (2-speed control)

The speed switching format controls the speed in high-speed and low speed.  
 The high-speed signal is turned ON when operating in the high-speed.  
 The low-speed signal is turned ON when operating in the low-speed.

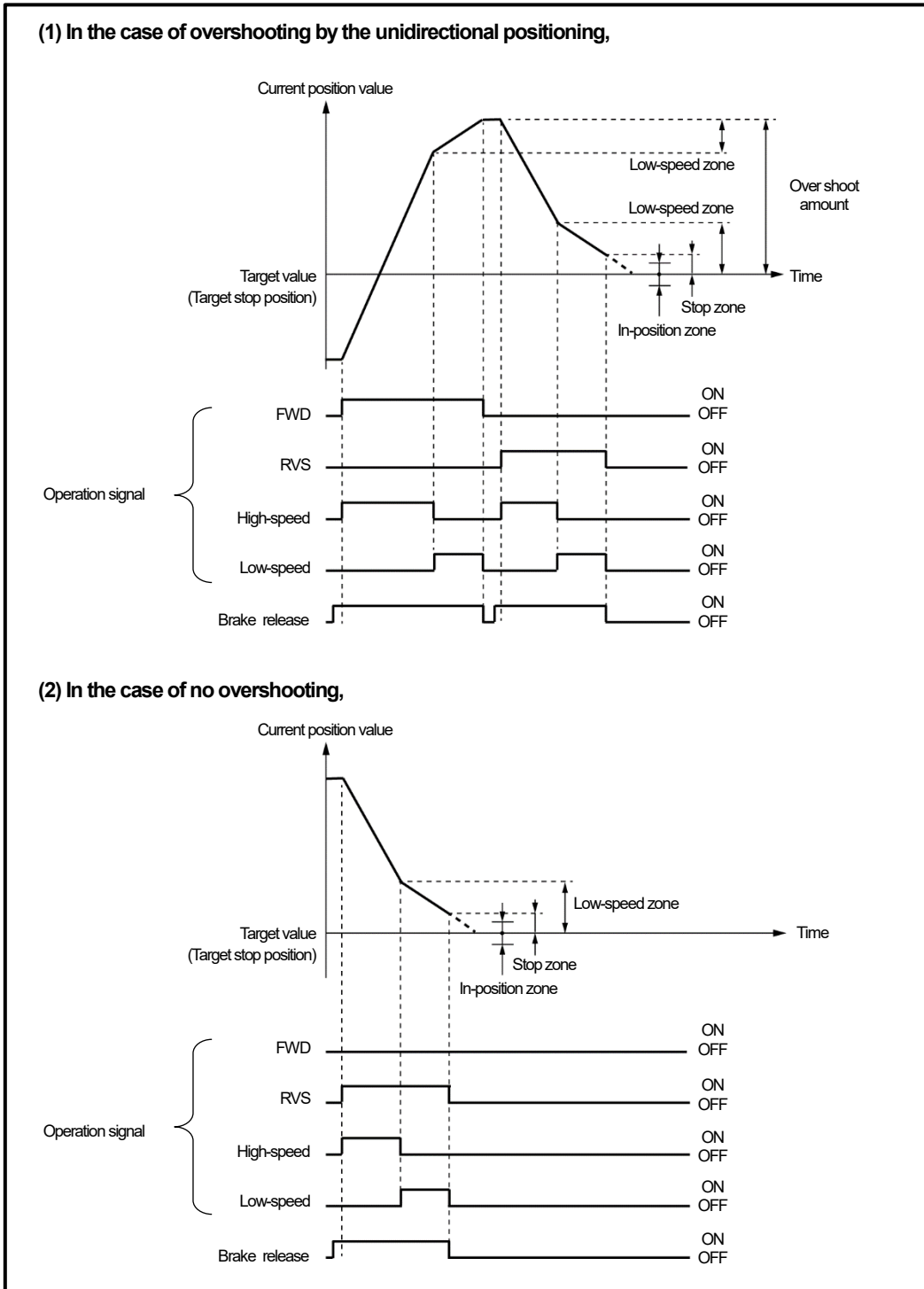

## 8.2.2 Speed stepping format (3-speed control)

The speed stepping format controls the speed in high-speed, medium-speed, and low speed. The speed is switched by outputting the duplicated operation signals.

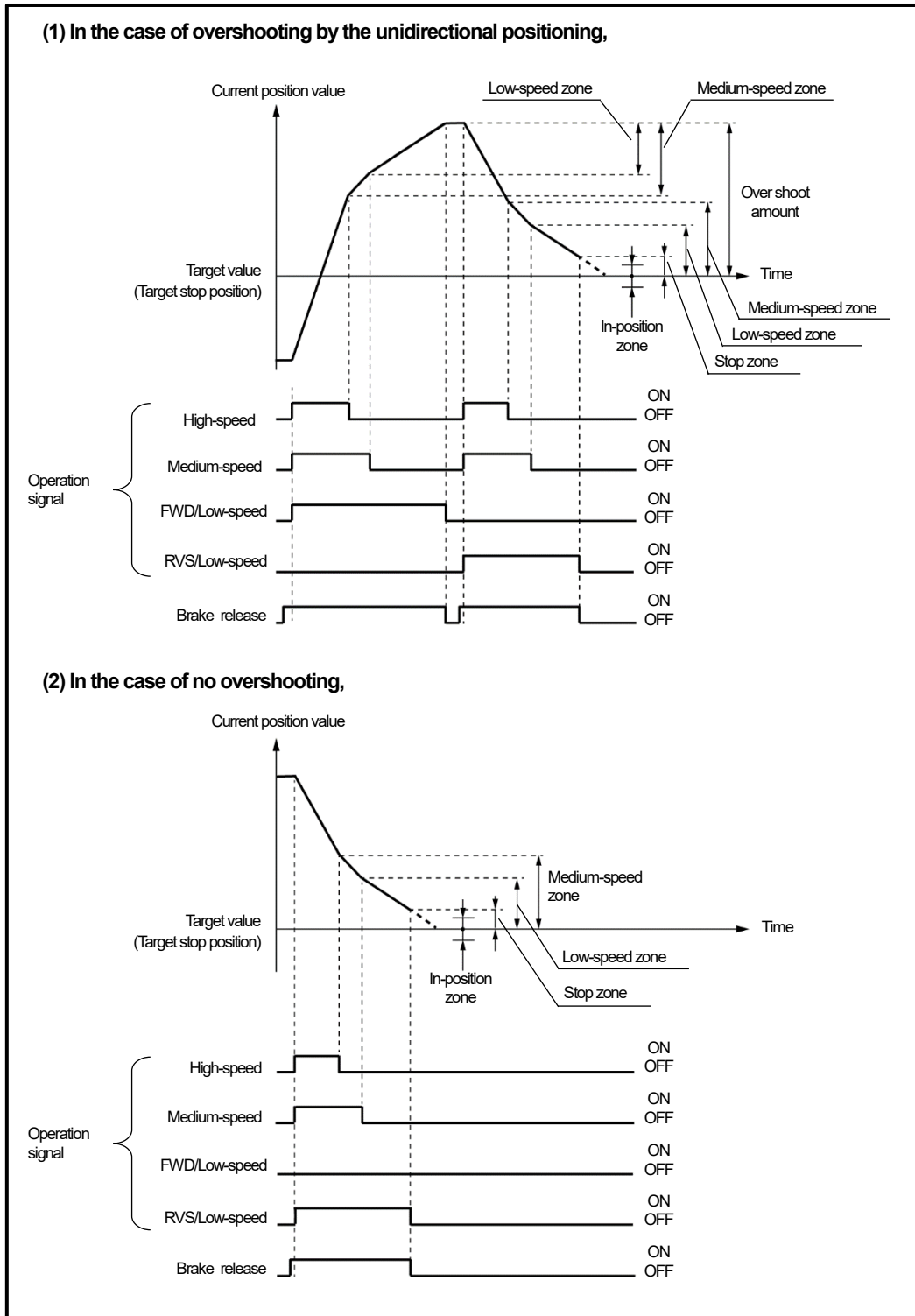

### 8.2.3 Simple learning function

The simple learning function is that corrects the stop zone automatically for the next positioning operation when a discrepancy occurs between the target value and current position value upon completion of the positioning.

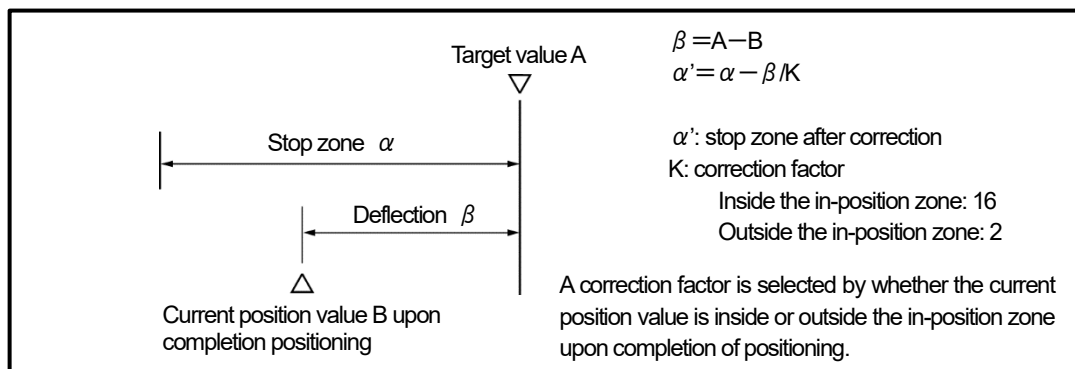

The corrected stop zone has two types (for FWD and RVS), and stored in the following areas.

A stop position that is used for the positioning is stored when the learning function is invalid.

Address	Contents
674(L) 675(H)	FWD stop zone after learning
676(L) 677(H)	RVS stop zone after learning

These areas are recovered in the buffer memory at next reapplying the power supply even if the power supply is turned OFF because they are stored in the internal memory (non-volatile memory).

#### ● Advantage

##### (1) Improving the stop accuracy

The stop accuracy to the target value improves.

##### (2) Easy adjustment of the stop zone

- In the case of the simple learning function is invalid,

The stop zone must be designated with the predicted value when setting 'stop zone' of the parameter.

- In the case of the simple learning function is valid,

'Stop zone' is automatically corrected the proper value by repeating the operation by simply setting any values.

##### (3) No stop zone correction required due to the worn brake

The stop zone is automatically corrected even for the amount of brake slippage due to aged deterioration is increased.

##### (4) No stop zone correction required due to reciprocating operations

A load fluctuation might occur with reciprocating operations such as the machine's up /down motion.

The stop zone of FWD or RVS direction\*1 can be corrected when using the simple learning function.

\*1: For the stop zone of FWD and RVS direction, a 600 number of the buffer memory address is used.

For more details, refer to 'Chapter 8.4'.

### ● Initialization (FWD and RVS stop zones after learning)

The learning data (FWD and RVS stop zones after learning) is initialized in the following cases;

- The learning data is changed to the parameter's stop zone (Address 720 and 721) when the positioning format (Address 712) is changed.
- The current stop zone setting value is stored in the learning data (Addresses 674 to 677) if the stop zone setting value is changed from the previous value when positioning starts.

#### IMPORTANT

The simple learning function doesn't correct the stop zone when executing 'START from stop zone'.

## 8.3 Unidirectional Positioning

Positioning toward the target stop position is always executed from a single direction.

When positioning is required in the opposite direction, the target stop position will be overshoot, and positioning will then occur from the prescribed direction (U-turn is made).

The distance from the target value to a point of making U-turn is called 'overshoot amount'.

The unidirectional positioning format is useful in reducing stop position errors caused by the backlash.

For the unidirectional positioning function, the following parameter is set.

For the parameter setting procedures, refer to 'Chapter 5.3'.

Address	Item	Contents	Setting range	Default
713	Positioning direction	Select the positioning direction.	0: FWD direction 1: RVS direction	0
714(L) 715(H)	Overshoot amount	Designate the distance by which the target value is overshoot before a U-turn is made when executing the "unidirectional positioning".	0 to 999999	100

● **Positioning direction (Address 713)**

0: FWD direction

Operates as the following figure ① and ②.

1: RVS direction

Operates as the following figure ③ and ④.

● **Overshoot amount (Address 714 and 715)**

0: The unidirectional positioning isn't executed. (no more overshooting)

1 to 999999: A distance indicated by 'L' is set in the following figure.

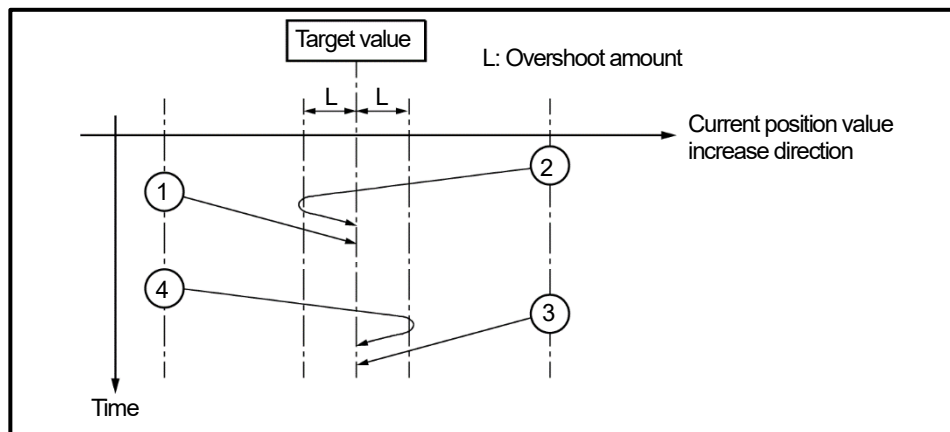

**IMPORTANT**

The following warning occurs and the positioning isn't executed when the current position value is exceeded the permissible setting range after the overshooting even though the target value is set in the permissible setting range.

- Device X7 (error detection) is turned ON.
- Error 41 occurs.

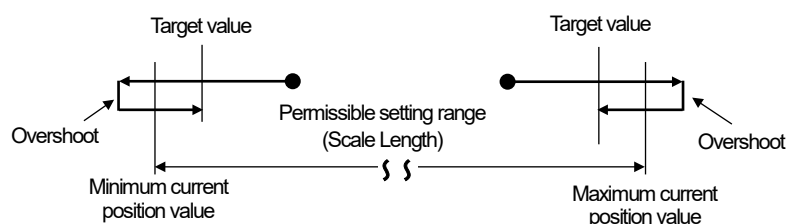



### 8.4 Positioning Pattern Data Setting

The positioning pattern data is data that switches the operation signal (high-speed, medium-speed, and low-speed). There is medium-speed zone, low-speed zone, stop zone, and in-position zone.

These zones are set the distance from the target value.

The relation between these zones and the target value is indicated below.

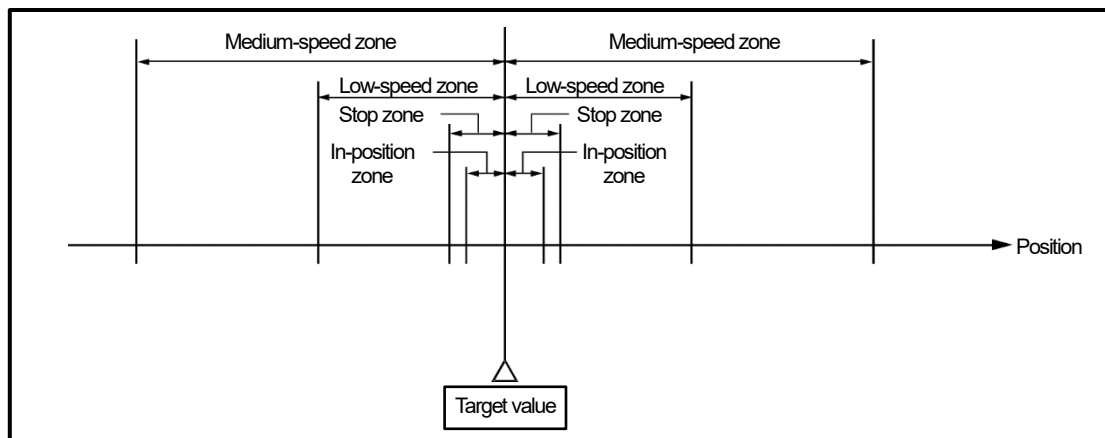

#### - Medium-speed zone

Uses in the speed stepping format (3-speed control)

The medium-speed zone is a position that is switched from high-speed to medium-speed, and a distance from the target value.

#### - Low-speed zone

The low-speed zone is a position that is switched from high-speed or medium-speed to low-speed, and a distance from the target value.

#### - Stop zone

The stop zone is a position that is applied to the brake, and a distance from the target value.

#### - In-position zone

The in-position zone is a reference distance uses to determine if the machine is stopped at the target value, and is a distance from the target value.

### ● Setting area of the positioning pattern data

The positioning pattern data can be set in two parts (parameter area and RAM area).

Using area is selected by 'positioning pattern data buffer memory selection (Address 679)'.

Item	Parameter area Address	RAM area Address
Medium-speed zone	716(L)	680(L)
	717(H)	681(H)
Low-speed zone	718(L)	682(L)
	719(H)	683(H)
FWD stop zone	720(L) 721(H)	684(L) 685(H)
RVS stop zone		686(L) 687(H)
In-position zone	722(L)	688(L)
	723(H)	689(H)

### ● Main usage for setting areas

#### - Parameter area

The area is used for 'RUN'.

The setting value is stored in VS-QA62's internal memory (non-volatile memory).

The writing operation to the internal memory is required by the data memory flag (Address 700) after writing the data in the buffer memory.

The data is read out from the internal memory to the buffer memory automatically when turning ON the power supply again.

#### - RAM area

The area is used for 'test RUN'.

The setting value is returned to the default value when the following operation is done because this area isn't backed up.

- Reset PLC CPU.
- Turn OFF the PLC power supply.

This area can work just by writing the data in the buffer memory by The TO instruction.

### 8.4.1 Setting of the positioning pattern data buffer memory selection

The using area of the positioning pattern data is selected.

Address	Item	Contents	Setting range	Default
679	Positioning pattern data buffer memory selection	Select the positioning pattern data area for use.	0: Parameter area 1: RAM area	0

This area can be designated just by writing the data to the buffer memory by the TO instruction.

The data can be written when online or offline.

The setting value is returned to the default when the following operation is done because this area isn't backed up.

- Reset PLC CPU.
- Turn OFF the PLC power supply.

#### ● Setting contents

0: Parameter area

1: RAM area

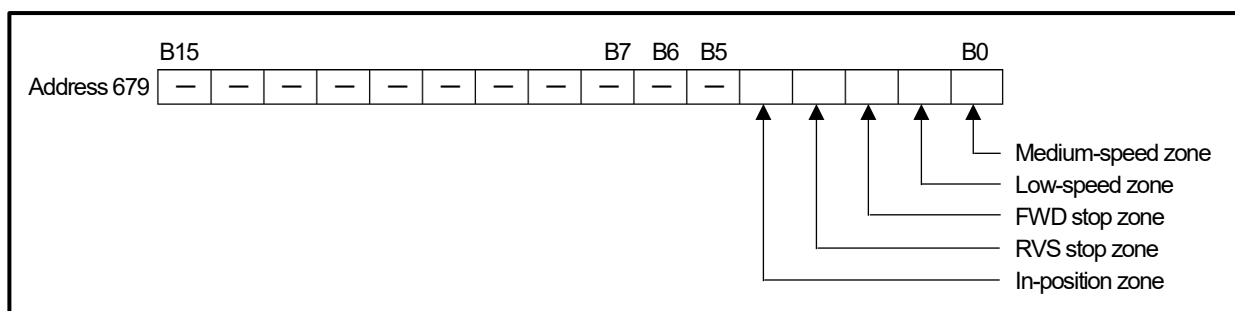

### 8.4.2 Parameter area settings

The medium-speed zone, low-speed zone, stop zone, and in-position zone are set in the following parameter area. For the parameter procedures, refer to 'Chapter 5.3'.

Address	Item	Contents	Setting range	Default
716(L) 717(H)	Medium-speed zone	Uses in the speed stepping format (3-speed control). Designate the distance from the target value at the position that is switched from high-speed to medium-speed.	0 to 999999	10000
718(L) 719(H)	Low-speed zone	Designate the distance from the target value at the position that is switched from high-speed or medium-speed to low-speed.	0 to 999999	1000
720(L) 721(H)	Stop zone	Designate the distance from the target value at the position that is applied to the brake.	0 to 999999	100
722(L) 723(H)	In-position zone	Designate a reference distance used to determine if the machine is stopped at the target value.	0 to 999999	100

### 8.4.3 RAM area settings

The medium-speed zone, low-speed zone, stop zone, and in-position zone are set in the following RAM area. This area can work just by writing the data in the buffer memory by the TO instruction.

Address	Item	Contents	Setting range	Default
680(L) 681(H)	Medium-speed zone	Uses in the speed stepping format (3-speed control) Designate the distance from the target value at the position that is switched from high-speed to medium-speed.	0 to 999999	Address 716
682(L) 683(H)	Low-speed zone	Designate the distance from the target value at the position that is switched from high-speed or medium-speed to low-speed.	0 to 999999	Address 718
684(L) 685(H)	FWD stop zone	Designate the distance from the target value at the position that is applied to the brake of the FWD direction.	0 to 999999	Address 720
686(L) 687(H)	RVS stop zone	Designate the distance from the target value at the position that is applied to the brake of the RVS direction.	0 to 999999	Address 720
688(L) 689(H)	In-position zone	Designate a reference distance used to determine if the machine is stopped at the target value.	0 to 999999	Address 722

### 8.4.4 Speed limitation

The speed limitation can be applied to this area for the test run and etc..

This area can be written to at any time by the TO instruction, but the setting applies only when the positioning START signal (Y11) is turned ON while online.

The setting value is returned to the default when the following operation is done because this area isn't backed up.

- Reset PLC CPU.
- Turn OFF the PLC power supply.

Address	Item	Contents	Setting range	Default
678	Speed limit	Designate the limit speed.	1: Speed stepping format (3-speed) (low-speed) Speed switching format (2-speed) (low-speed)  2: Speed stepping format (3-speed) (medium-speed) Speed switching format (2-speed) (no limit)  3: Speed stepping format (3-speed) (no limit) Speed switching format (2-speed) (no limit)	3

#### ● Setting contents

Setting value	Speed stepping format (3-speed control)	Speed switching format (2-speed control)
1	Positioning only at low speed	Positioning only at low speed
2	No output at high speed	No speed limitation applied
3	No speed limitation applied	

### 8.5 Upper / Lower Overtravel Detection Function

The upper and lower overtravel detection function is that monitors the current position value that exceeds the upper limit value or lower limit value.

The following warnings occur when exceeding the upper limit value.

- Device X2 (upper limit overtravel detection) is turned ON.
- Error 20 occurs.

The following warnings occur when exceeding the lower limit value.

- Device X3 (lower limit overtravel detection) is turned ON.
- Error 21 occurs.

However, the positioning is executed even though a warning occurs.

The upper/lower limit value is set in the following parameter..

For the parameter setting procedures, refer to 'Chapter 5.3'.

Address	Item	Contents	Setting range	Default
724(L) 725(H)	Upper limit value (+limit)	Designate the '+' direction limit value.	-99999 to 999999	999999
726(L) 727(H)	Lower limit value (-limit)	Designate the '-' direction limit value.	-999999 to 999999	-999999

#### (1) Warning clearing method

Turn ON (leading edge) Device Y16 (error reset).

## 8.6 'START from Stop Zone' Function

The 'START from stop zone' function is that executes the positioning from the stop zone.

For example, the positioning operation can be executed again if the machine stops at the outside of the in-position zone upon the completion of the positioning operation.

The 'START from stop zone' operates as below.

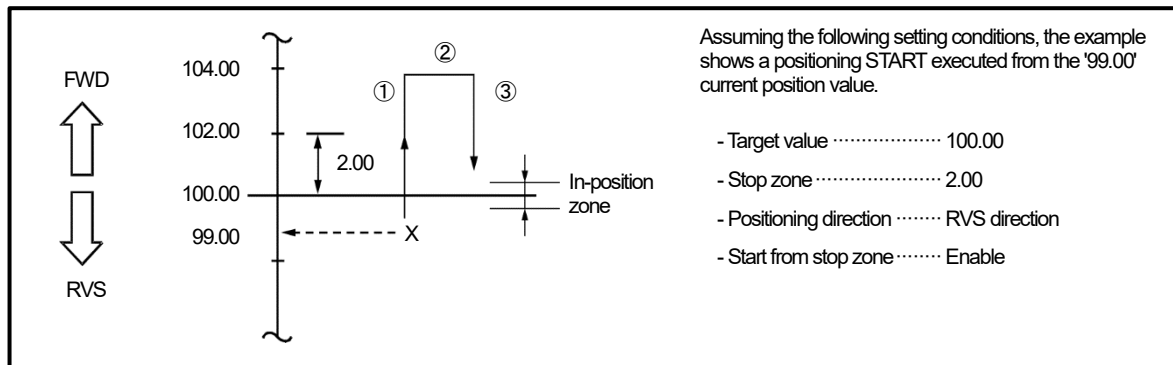

● **Operation explanation**

- ① Move the current position twice the distance of the stop zone, in the opposite direction to the parameter designated positioning direction (Address 713).
- ② Stop the movement at that position.
- ③ The positioning executes again toward the target value.

The 'START from stop zone' function is set in the following parameter.

For the parameter setting procedures, refer to 'Chapter 5.3'.

Address	Item	Contents	Setting range	Default
728	Start from stop zone	Designate whether the positioning is executed when the START position is already within the stop zone.	0: Disable 1: Enable	1

● **Operation conditions**

(1) **In the case of setting '0: disable' to 'START from stop zone (Address 728)' of the parameter,**

The positioning isn't executed within the stop zone.

The 'positioning in progress' signal will be turned ON in the following timing if the positioning START signal (Y11) turned ON.

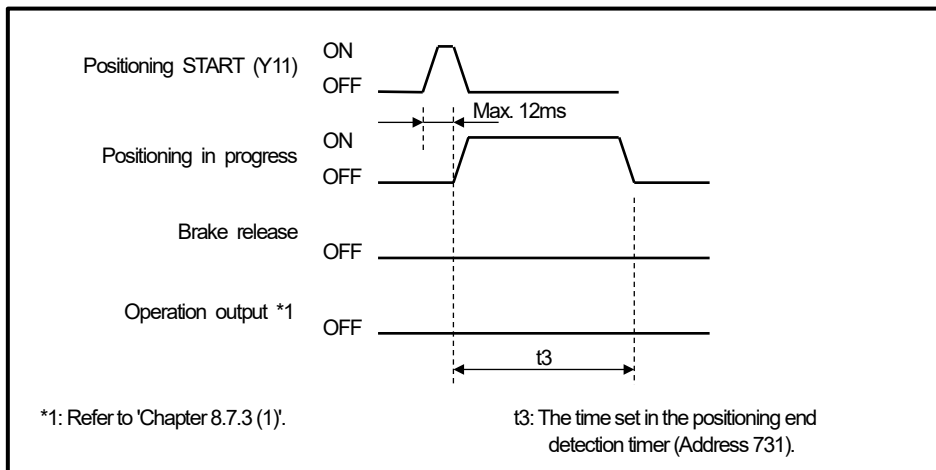

(2) **In the case of the positioning starts from 'in-position' zone,**

The positioning isn't executed within the in-position zone.

The 'positioning in progress' signal will be turned ON in the following timing same as above (1) if the positioning START signal (Y11) turned ON.

**IMPORTANT**

The machine moves to the position twice the distance of the stop zone when the 'START from Stop Zone' is executed.

The following warnings occur and the positioning isn't executed when this position exceeds the permissible setting range.

- Device Y7 (error detection) is turned ON.
- Error 41 occurs.

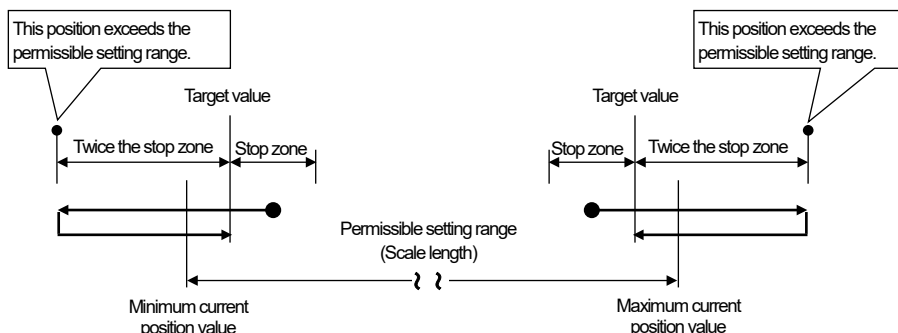

## 8.7 Positioning Operation

The positioning operation starts when turning ON (leading edge) the positioning START signal (Y11) after setting the target value.

The FWD JOG signal (Y13) and RVS JOG signal (Y14) aren't accepted during the positioning operation.

Turn ON the positioning STOP signal (Y12) when canceling the operation.

### ● Operation conditions

- ① The status is online (Y10 is ON).
- ② The positioning STOP signal (Y12) isn't turned ON.
- ③ The operation error signal isn't turned ON.
- ④ No sensor error occurs (error code 22).
- ⑤ Not in JOG operation

### 8.7.1 Procedure for the positioning operation

The procedures for the positioning operation are indicated below.

#### ● Procedure

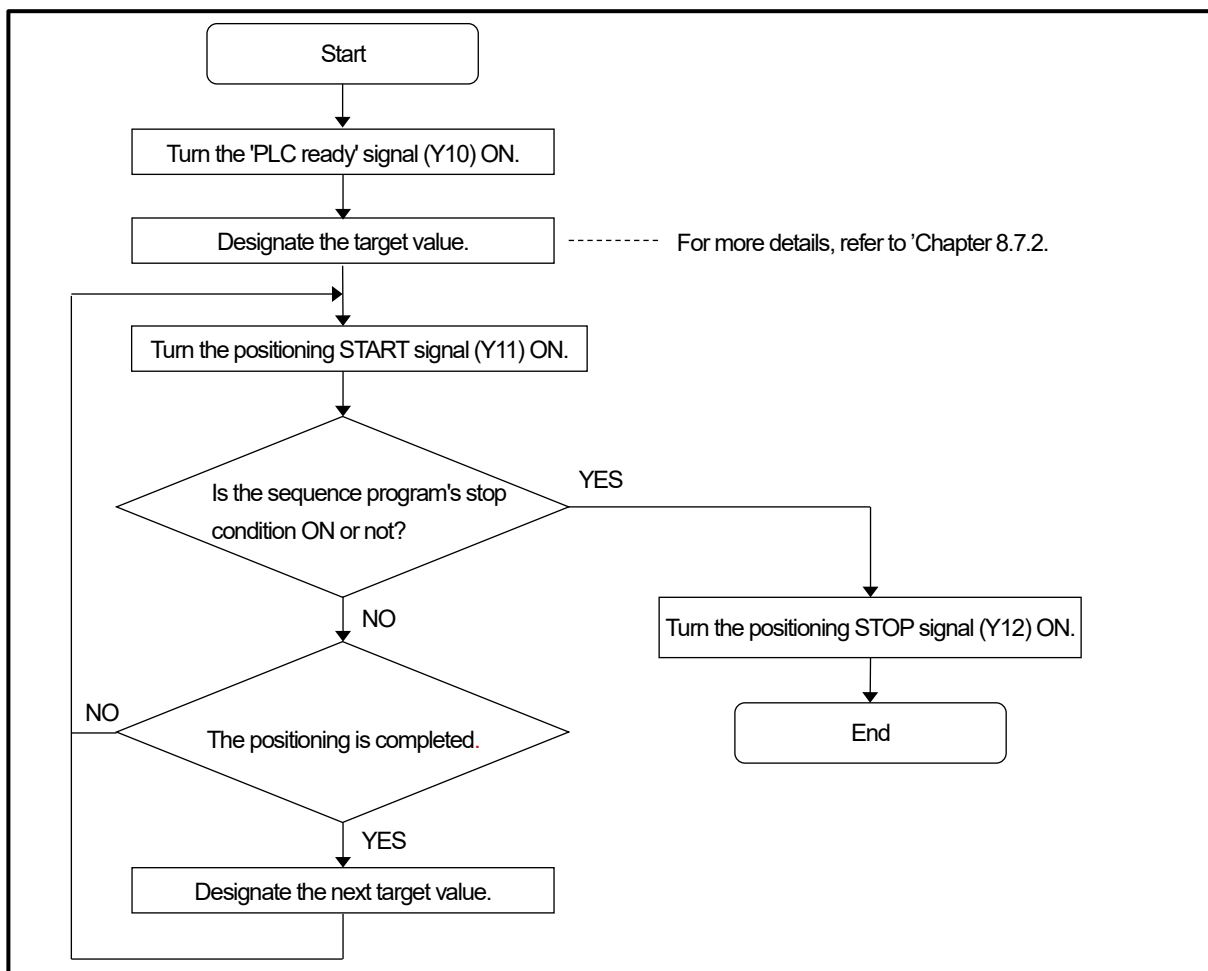



### 8.7.2 Positioning target stop position setting

The positioning target stop position (Address 10 and 11) designates the target value for the positioning operation. This area can be written to at any time by the TO instruction, but the setting applies only when the positioning START signal (Y11) is turned ON while online.

Address	Item	Contents	Setting range	Default
10(L) 11(H)	Target stop position setting data (scaling binary)	Designate the target value for the positioning operation.	Minimum current position value to [minimum current position value + scale length -1]	0

(1) The setting value is written as a scaling binary value.

(2) The permissible setting range is as follows:

[Minimum current position value] to [Minimum current position value + scale length -1].

(3) The following warnings occur if the value that is out of the permissible setting range is set.

- Device X7 (error detection) is turned ON.
- Error 41 occurs.

Moreover, warnings also occur in the followings;

- In the case of the positioning overshoots and the current position value is exceeded the permissible setting range,  
For details, refer to 'Chapter 8.3'.
- In the case of the current position value is exceeding the permissible setting range when executing the 'start from the stop zone',  
For details, refer to 'Chapter 8.6'.

#### IMPORTANT

The positioning target isn't changed even if the positioning target stop position (target value) is changed during the positioning operation.

The setting is valid when the positioning START signal (Y11) is turned ON again after completing the positioning cycle ('positioning in progress' signal is OFF.).

## 8.7.3 Controlling timing

### (1) Positioning START

The positioning START signal (Y11) is turned ON (leading edge) when starting the positioning operation. The below figure indicates an example when the positioning overshoots in unidirectional positioning.

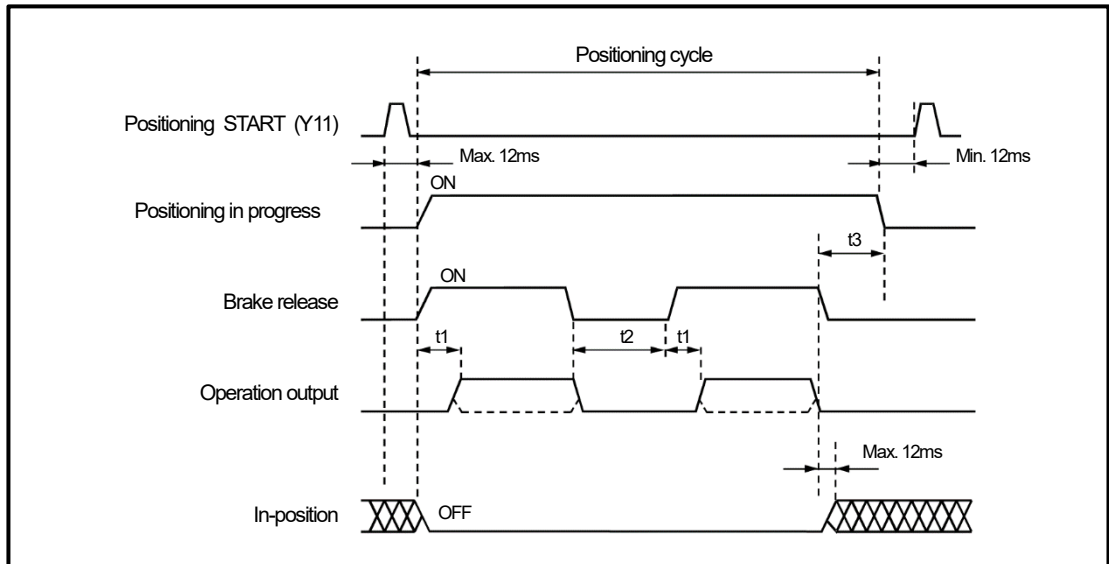

#### Operation output

The following signals are called 'operation output'.

Speed switching format (2-speed control)	FWD, RVS, high-speed, low-speed
Speed stepping format (3-speed control)	FWD/low-speed, RVS/low-speed, high-speed, medium-speed

#### t1: ON delay period of the operation output

Delay period from the point when the brake is released until the point when the operation output comes ON

$$t1 \leq 10\text{ms}$$

#### t2: Time for figuring out 'STOP' when overshooting

'Time for figuring out whether the machine stopped at the overshoot position or not. During this time, the machine stops, and the operation output and brake release signal are turned OFF.

VS-QA62 compares the current position value (sensor binary value) per 100ms, and recognizes 'STOP' when the change amount becomes plus/minus 2 digits or less.

After that, the machine is moved in the opposite direction.

#### t3: OFF delay period of the 'positioning in progress' signal

Delay period from the point when the 'brake release' signal goes OFF (brake ON) to the point when the 'positioning in progress' signal goes OFF (positioning is completed).

The 't3' period is designated by the following parameter (Address 731).

For the parameter setting procedures, refer to 'Chapter 5.3'.

Address	Item	Contents	Setting range	Default
731	Positioning end detection timer	Designate the OFF delay period of the 'positioning in progress' signal upon completion of positioning.	0 to 9999 (Setting units: 10ms)	10

### In-position signal behavior

The in-position signal is turned ON when the current position value enters the in-position zone during online. Check the 'in-position' signal whether the current position enters in the 'in-position' zone.

In the following cases, the in-position signal isn't turned ON.

- During the positioning (except t3 period)
- Passing the in-position zone (target value) by overshooting
- When turning ON the power supply
- When switching online to offline

(The in-position signal will be turned ON if the current position value is in the in-position zone when switching online again.)

The in-position zone is designated at the parameter's in-position zone (Address 722 and 723). For the details of the in-position zone, refer to 'Chapter 8.4'.

### In the case of the current position value is outside of the 'in-position' zone after the positioning cycle,

Even when the current position value following the completion of the positioning cycle is outside the in-position zone, the positioning operation will not be resumed.

### In the case of the positioning starts from 'in-position' zone,

The positioning isn't executed within the in-position zone.

The 'positioning in progress' signal will be turned ON in the following timing if the positioning START signal (Y11) turned ON.

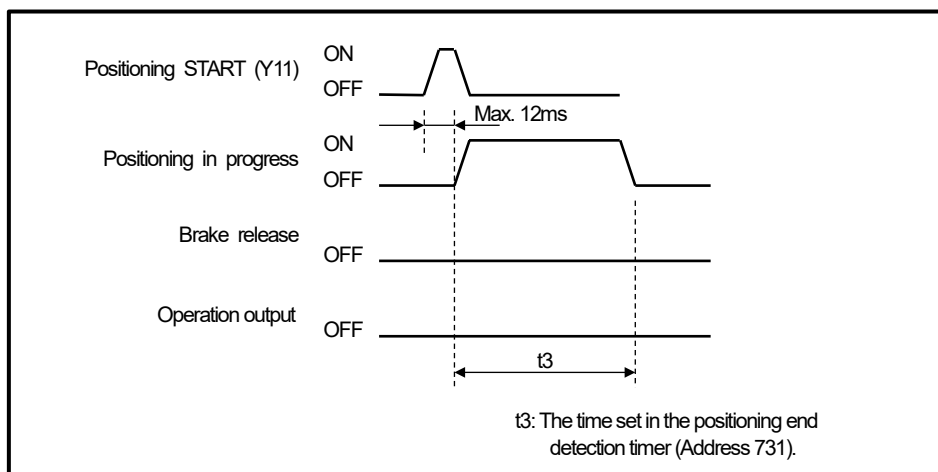

### Interlock

Although the FWD and RVS signals of operation output have never output simultaneously, add a 'hardware interlock' condition to the motor, etc., drive circuits as an additional precaution.

## (2) Positioning STOP

The positioning STOP signal (Y12) is turned ON when you desire to stop the positioning during the operation.

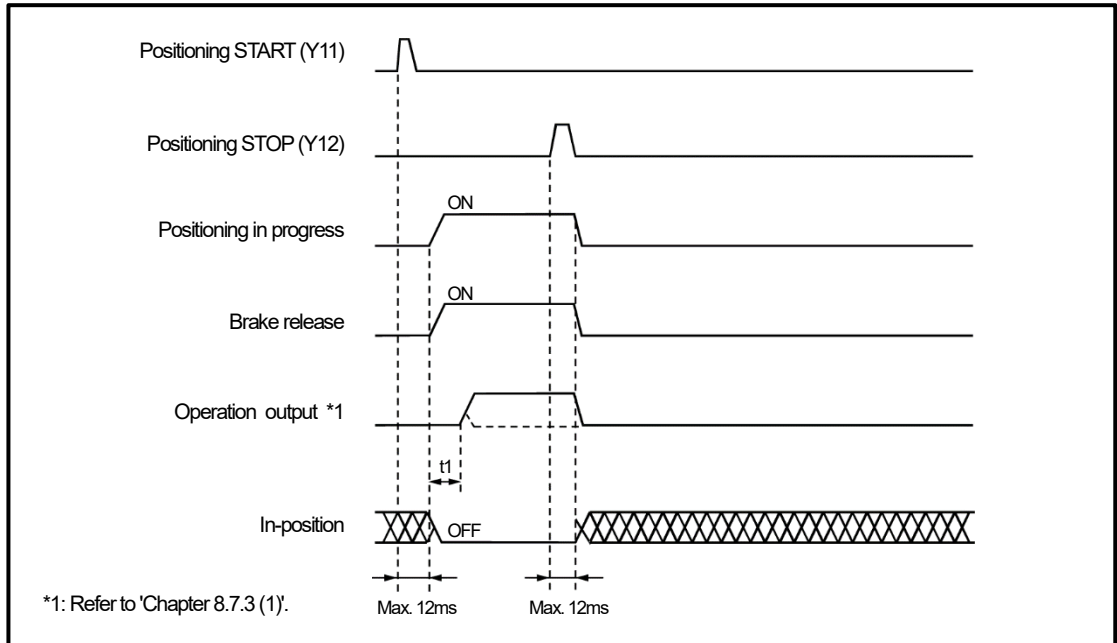

## 8.7.4 Positioning output status area (Address 696)

This is the area that stores the positioning output signal status.

The positioning output signal is output to the bit as below figure.

'1' is stored when the positioning output signal is ON.

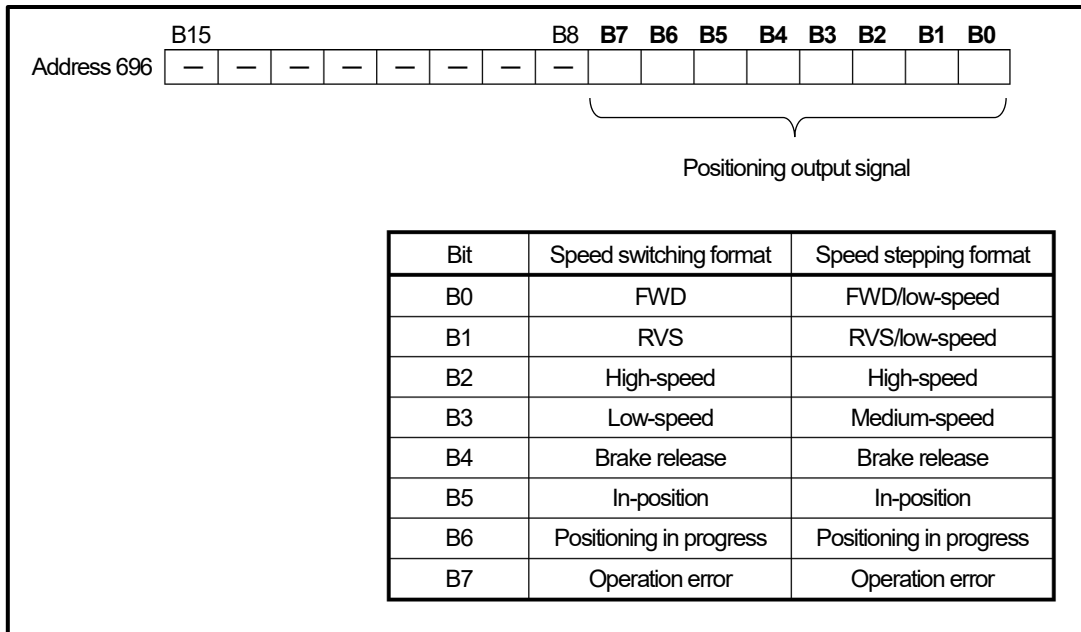

### 8.7.5 Current position preset during the positioning operation

The current position preset function is operative even when positioning is in progress. The resulting operation is explained below.

**(1) When the positioning direction is not changed as a result of the current position preset function:**

The positioning operation is not interrupted.

The positioning operation is controlled based on the current position value which is after the current position preset function is executed. Therefore, the positioning operation signal might switch from high speed to medium speed or low speed depending on the distance between this current position value and the target value.

**(2) When the positioning direction is reversed as a result of the current position preset function:**

The positioning operation will be stopped, and after a 'stop detection' has occurred, the positioning operation will be automatically re-started based on the current position value which is after the current position preset function is executed.

After being re-started, positioning operation occurs in the normal manner. The overshooting and START from stop zone operation are executed depending on the stop position.

**(3) When the positioning direction isn't changed and the current position value is within the stop zone as a result of the current position preset function:**

It is the same as the normal positioning operation.

In the case of the positioning operation other than the target value such as overshoot operation or 'START from stop zone' is in progress, the positioning starts to the target position after a 'stop detection' has occurred.

In the case of the positioning operation to the target value is in progress, the positioning operation is ended after the time which is designated to the 'positioning end detection timer'(Address 731) has elapsed.

**(4) STOP recognition**

VS-QA62 compares the current position value (sensor binary value) per 100ms, and recognizes 'STOP' when the change amount becomes plus/minus 2 digits or less.

**(5) How to prohibit the current position preset during the positioning operation:**

Turn ON the following device signals by the sequence program.

- Current position preset 1 prohibit signal (Y17)
- Current position preset 2 prohibit signal (Y18)

However, the current position preset prohibit signal is valid only when selecting 'parameter format' or 'buffer memory format' for the current position preset function (Address 748).

### 8.8 JOG Operation

The JOG operation executes during turning the FWD or RVS JOG signal (Y13/Y14) ON.

The positioning START signal (Y11) isn't accepted during the JOG operation.

The operation stops when turning the FWD JOG signal (Y13) and RVS JOG signal (Y14) ON simultaneously.

#### ● Operation conditions

- ① The status is online (Y10 is ON).
- ② The operation error signal isn't ON
- ③ The 'positioning in progress' signal isn't ON.
- ④ No sensor error (error code 22)

#### ● JOG low-speed timer

The JOG low-speed timer designates the low-speed time during the JOG operation.

The operation output is switched from low-speed to high-speed after the setting time has elapsed during FWD or RVS JOG signal (Y13/Y14) continues ON.

The setting unit is 10ms.

The operation output becomes low-speed constantly if the timer is designated to 9999 (99.99s).

The JOG low-speed timer is designated in the following parameter.

For the parameter setting procedures, refer to 'Chapter 5.3'.

Address	Item	Contents	Setting range	Default
732	JOG low-speed timer	Designate the low-speed operation period for the JOG operation.	0 to 9999 When '9999', 'Low-Speed' is always specified. (Setting units: 10ms)	9999

● Timing chart

(1) FWD JOG operation

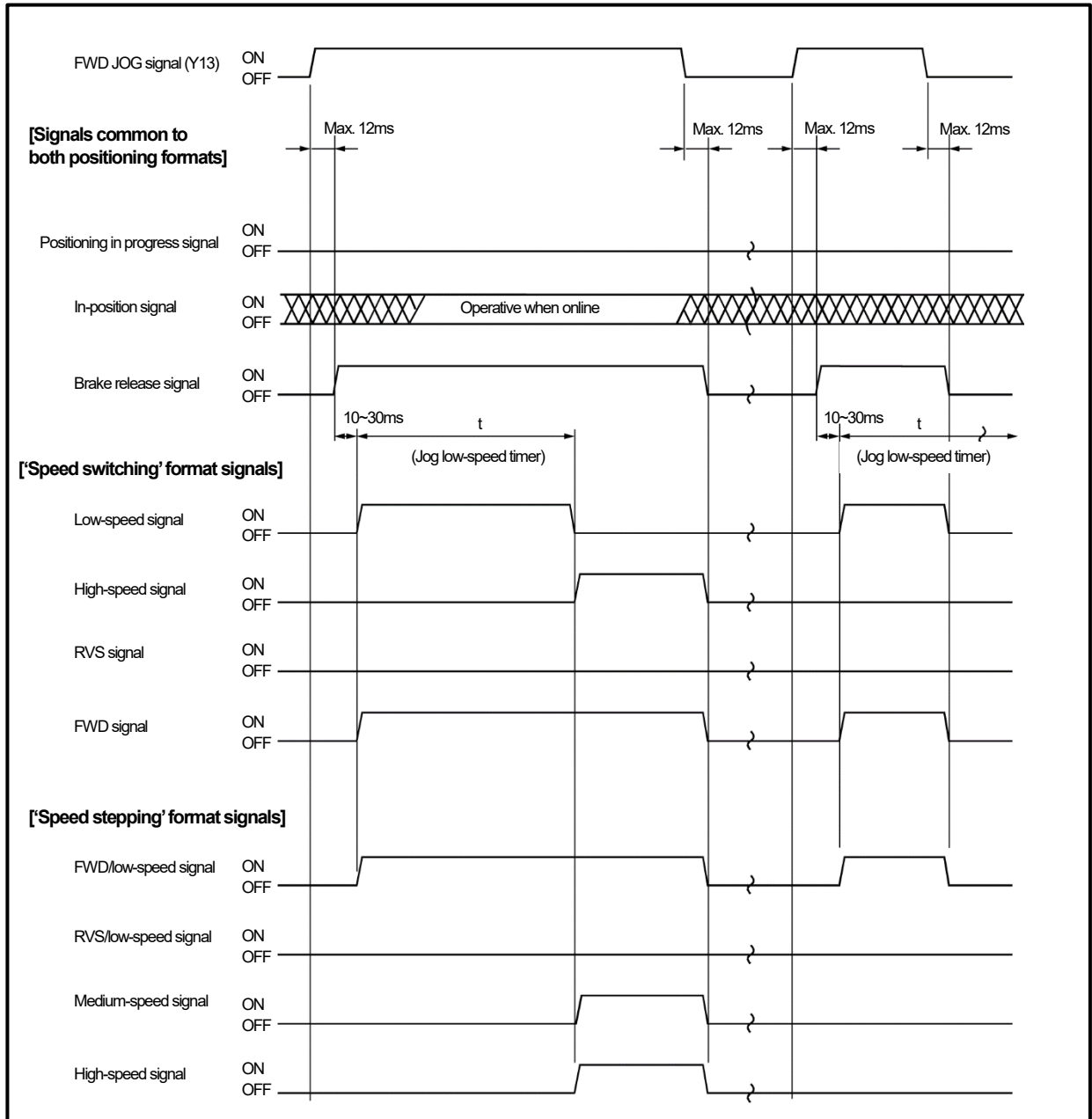

t: JOG low-speed timer of the parameter (Address 732)

The operation output is switched from low-speed to high-speed after setting time has elapsed during the JOG signal continues ON.



## (2) RVS JOG operation

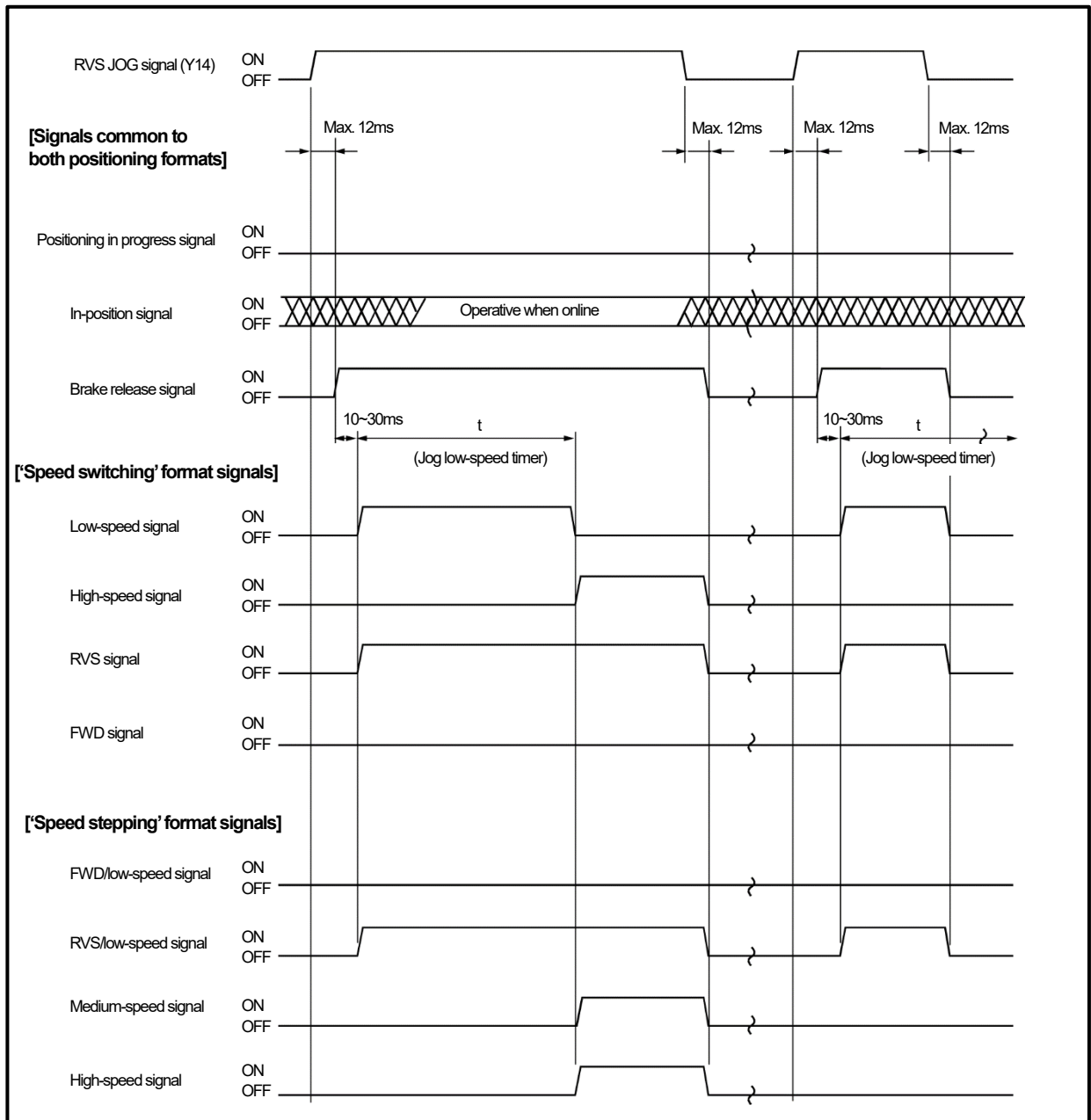

t: JOG low-speed timer of the parameter (Address 732)

The operation output is switched from low-speed to high-speed after setting time has elapsed during the JOG signal continues ON.

## 8.9 Operation Error

When the following errors are detected during a JOG or positioning operation, the operation will automatically be stopped (operation output OFF). At this time, an operation error signal\*1 is output (turn ON).

The JOG or positioning operation cannot be executed while the operation error signal is ON.

- (1) Sensor error (error code 22)
- (2) Motion detection error (error code 42)
- (3) Motion direction error (error code 43)
- (4) Detection range over (error code 44) \*2
- (5) Learning data error (error code 25) \*2

**Point**

\*1: The operation error signal is output to the following 4 locations.

- Device XF
- 7 in the upper row of the panel monitor LEDs
- 8-pin of the external I/O connector
- Bit 7 of the buffer memory address 696

\*2: Errors don't occur during the JOG operation.

VS-QA62 continues the operation even when other errors except the above errors occur.

Turn the device Y12 (positioning STOP signal) ON when you desire to stop.

● **Error clearing method**

Turn ON (leading edge) Device Y16 (error reset).

Turns OFF the operation error signal.

**(1) Sensor error (error code 22)**

A sensor error occurs in the following cases;

- The ABSOCODEDR sensor isn't connected.
- The cable for ABSOCODER is disconnected.
- The position detection circuit inside of VS-QA62 has a failure.

**(2) Motion detection error (error code 42)**

The 'motion detection error' checks whether the current position value is changed while outputting the operation output signal.

This error occurs when the current position value isn't changed.

VS-QA62 compares the current position value (sensor binary value) per 0.5s, and recognizes 'STOP' when the change amount becomes plus/minus 2 digits or less.

A 'non-detection period' can be set with considering the response delay of the external motor drive circuits.

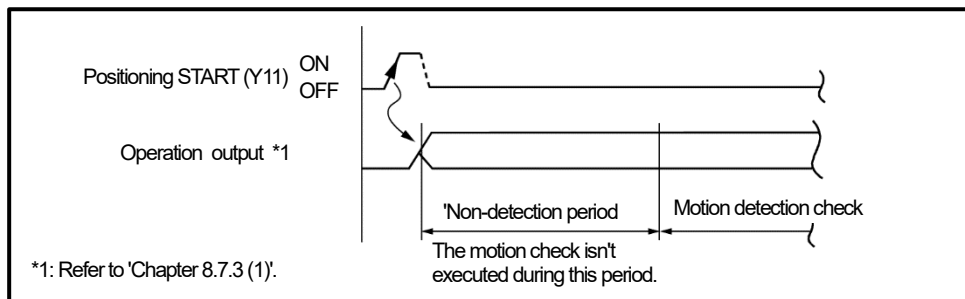

The 'non-detection period' is designated in the following parameter.

This error doesn't occur because the motion check isn't executed when setting '0'.

For the parameter setting procedures, refer to 'Chapter 5.3'.

Address	Item	Contents	Setting range	Default
729	Motion non-detection timer	Designate the period from the point when positioning is started until the point when the 'motion detection check' starts.	0 to 9999 (Setting units: 10ms)	1000

### (3) Motion direction error (error code 43)

The 'motion direction error' check whether the current position value changes in the direction opposite to the direction command of the operation output.

This error occurs when the current position value is changed in the opposite direction.

VS-QA62 compares the current position value (sensor binary value) change per 0.5s, and recognizes error when the change amount to the opposite direction becomes plus/minus 3 digits or more.

A 'non-detection period' can be set with considering the response delay of the external motor drive circuits.

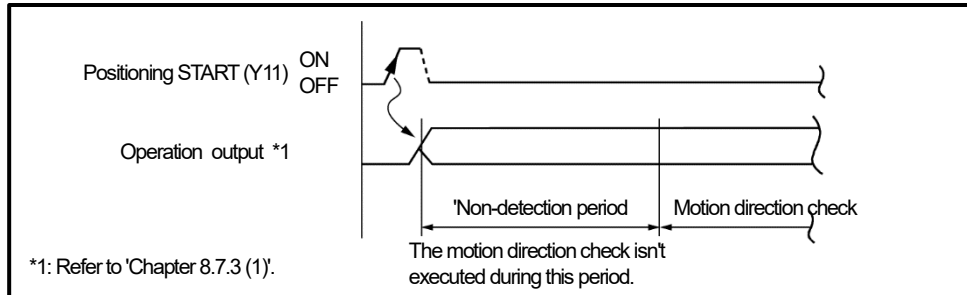

The 'non-detection period' is designated in the following parameter.

This error doesn't occur because the motion check isn't executed when setting '0'.

For the parameter setting procedures, refer to 'Chapter 5.3'.

Address	Item	Contents	Setting range	Default
730	Motion misdirection non-detection timer	Designate the period from the point when positioning is started until the point when the 'motion direction check' starts.	0 to 9999 (Setting units: 10ms)	1000

### (4) Detection range over (error code 44)

The detection range over occurs when the current position value exceeds the detection range during the positioning.

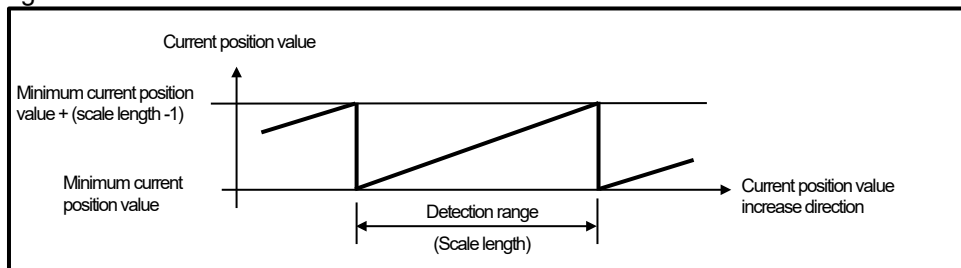

In the condition that the current position exceeds the detection range, VS-QA62 controls that the current position moves to the opposite direction more if the positioning operation to the target value same as before is executed.

Move back the current position value to the detection range using JOG operation etc. after clearing the error if the current position value exceeds the detection range, and restart the operation.

**IMPORTANT**

Do not use around both ends of the detection range when the positioning operation. Moreover, install the mechanical type of the limit switches for multiple safety measures.

### (5) Learning data error (error code 25)

The learning data error occurs when the corrected stop zone by the simple learning function is exceeds the low-speed zone.

The 'stop zone after learning (Addresses 674 to 677)' becomes the same value as the low-speed zone when a learning data error occurs.

## 9. POSITIONING (ACCELERATION/DECELERATION CONTROL)

The positioning function is that stops the machine to the designated position.  
This chapter explains the acceleration/deceleration control format.

For acceleration/deceleration control format, the parameters, positioning pattern data, and target values (stop position) are set to VS-QA62 in advance.

VS-QA62 outputs 'speed command'<sup>\*1</sup> according to positioning pattern data' and the motor control signal by comparing the current position value (machine position) detected by the ABSOCODER sensor and setting value.

<sup>\*1</sup>: The speed command outputs to the external I/O connector (13 and 26 pins) and buffer memory (Address 697 and 698).

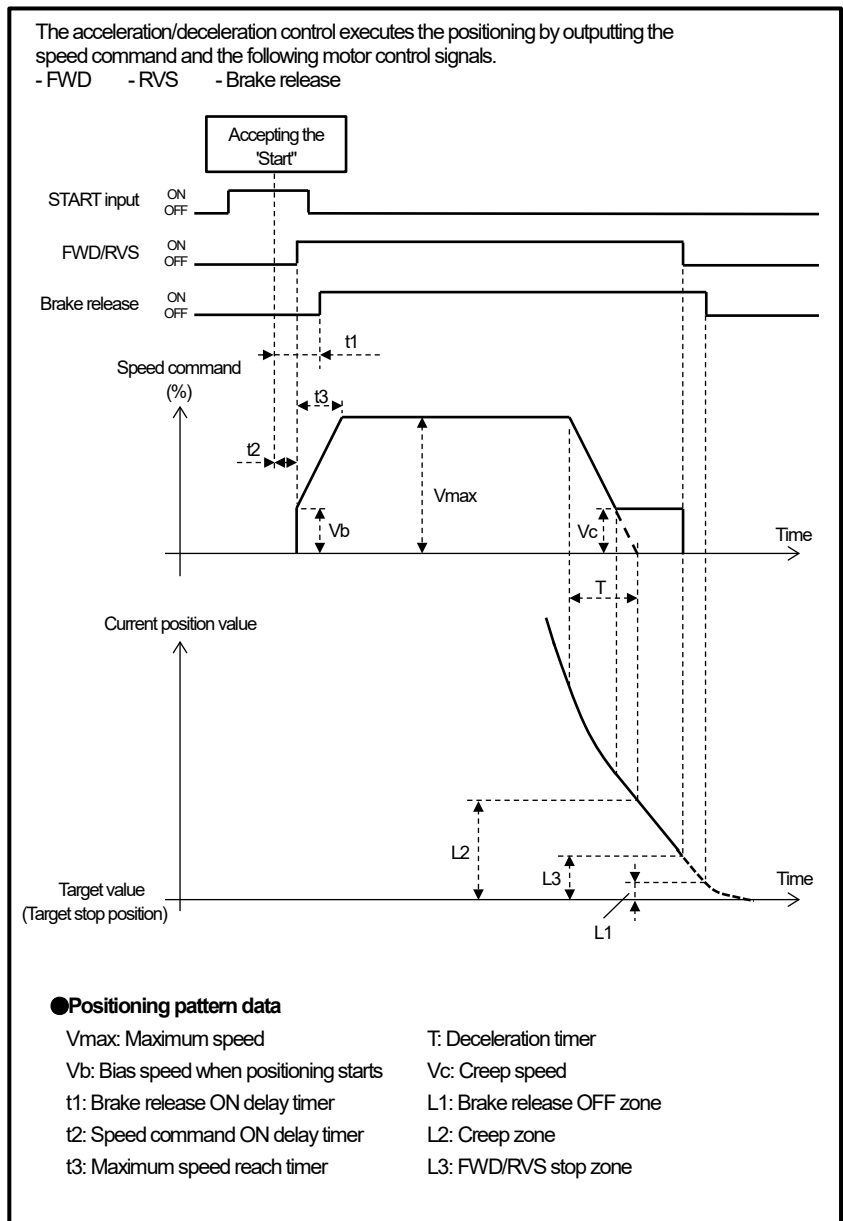
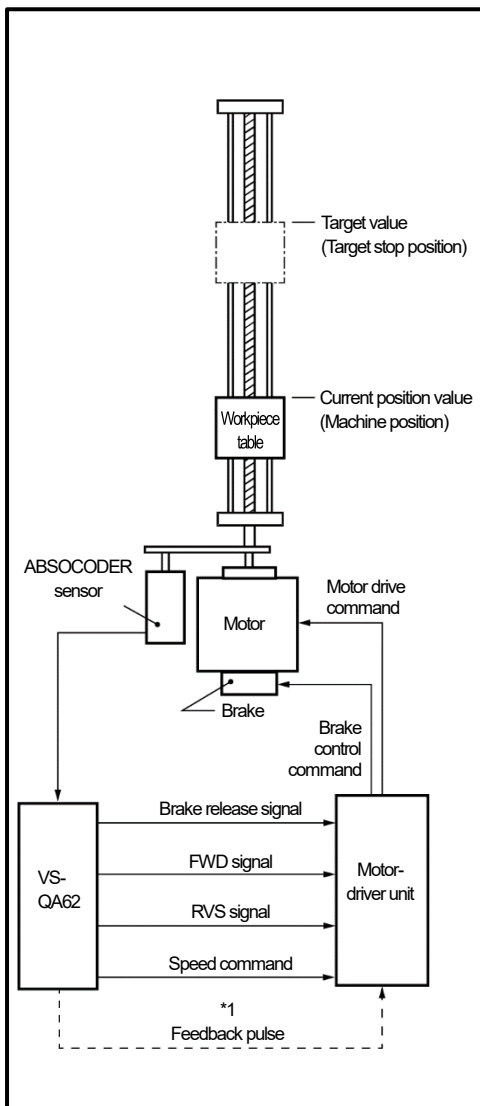

<sup>\*2</sup>: Positioning responsiveness can be improved by inputting the pulse output of the current position detection function to the vector control inverter.

(Note)

The performance might not archive well if the number of pulses per motor revolution is small.

## 9. POSITIONING FUNCTION (ACCELERATION/DECELERATION CONTROL)

MELSEC-Q

### 9.1 Parameter Related to the Acceleration/Deceleration Control

The parameters list related to the acceleration/deceleration control is indicated below.

They should be set for each function and set them when you need.

For more detailed functions, see the reference chapter.

For the parameter setting procedures, refer to 'Chapter 5.3'.

#### ● Parameter list

1/2

Address	Item	Contents	Setting range	Default	Reference (Chapter No.)
711	Output signal selection	Select the signal contents which are output to the external I/O connector (1 to 8) and device (X8 to XF).	0: Positioning output 1: Limit switch output 2: Current position detection (No signal output)	2	7.3
712	Positioning format	Select the positioning format.	0: Speed switching format (2-speed) without learning function 1: Speed stepping format (3-speed) without learning function 2: Speed switching format (2-speed) with learning function 3: Speed stepping format (3-speed) with learning function 4: Acceleration/Deceleration control format without learning function 5: Acceleration/Deceleration control format with learning function	0	9.2
713	Positioning direction	Select the positioning direction.	0: FWD direction 1: RVS direction	0	9.3
714(L) 715(H)	Overshoot amount	Designate the distance by which the target value is overshoot before a U-turn is made when executing the "unidirectional positioning".	0 to 999999	100	9.3
722(L) 723(H)	In-position zone	Designate a reference distance used to determine if the machine is stopped at the target value.	0 to 999999	100	9.4
724(L) 725(H)	Upper limit value (+limit)	Designate the '+' direction limit value.	-99999 to 999999	999999	9.5
726(L) 727(H)	Lower limit value (-limit)	Designate the '-' direction limit value.	-99999 to 999999	-99999	9.5
728	Start from stop zone	Designate whether the positioning is executed when the START position is already within the stop zone.	0: Disable 1: Enable	1	9.6
729	Motion non-detection timer	Designate the period from the point when positioning is started until the point when the 'motion detection check' starts.	0 to 9999 (Setting units: 10ms)	1000	9.11
730	Motion misdirection non-detection timer	Designate the period from the point when positioning is started until the point when the 'motion direction check' starts.	0 to 9999 (Setting units: 10ms)	1000	9.11
731	Positioning end detection timer	Designate the OFF delay period of the 'positioning in progress' signal upon completion of positioning.	0 to 9999 (Setting units: 10ms)	10	9.7.4
732	JOG low-speed timer	Designate the low-speed operation period for the JOG operation.	0 to 9999 When '9999', 'Low-Speed' is always specified. (Setting units: 10ms)	9999	9.10

## 9. POSITIONING FUNCTION (ACCELERATION/DECELERATION CONTROL)

MELSEC-Q

2/2

Address	Item	Contents	Setting range	Default	Reference (Chapter No.)
751	Analog output data selection	Select the analog output data.	0: No output (Fixed at 0) 1: Absolute value speed command (0 to 100%) 2: Speed command (-100 to 100%) 3: Current speed 4: Current position (scale value)	0	9.8.1
752(L) 753(H)	Maximum output voltage (Vmax)	Designate the analog output maximum voltage.	Vmin to 10.00 [V]	1000	9.8.1
754(L) 755(H)	Minimum output voltage (Vmin)	Designate the analog output minimum voltage.	-10.00 to Vmax [V]	0	9.8.1
756(L) 757(H)	Maximum output value	Designate the <b>value</b> *1 for outputting maximum voltage.	-999999 to 999999	100	9.8.1
758(L) 759(H)	Minimum output value	Designate the <b>value</b> *1 for outputting minimum voltage .	-999999 to 999999	0	9.8.1
760	JOG low-speed (V1)	Designate the low-speed operation speed during the JOG operation.	0 to 100 %	10	9.10
761	JOG high-speed (V2)	Designate the high-speed operation speed during the JOG operation.	0 to 100 %	10	9.10

\*1: The unit of value is varied depending on the data selected in Address 751.

## 9.2 Positioning Format and Simple Learning Function Selection

The positioning format is selected.

In addition, the simple learning function is selected to either valid or invalid.

The positioning format and simple learning function can be selected by the following parameter.

Address	Item	Contents	Setting range	Default
712	Positioning format	Select the positioning format.	0: Speed switching format (2-speed) without learning function 1: Speed stepping format (3-speed) without learning function 2: Speed switching format (2-speed) with learning function 3: Speed stepping format (3-speed) with learning function 4: Acceleration/Deceleration control format without learning function 5: Acceleration/Deceleration control format with learning function	0

● **Setting contents**

Designate '4' or '5' to the acceleration/deceleration control format.

For the parameter setting procedures, refer to 'Chapter 5.3'.

## 9.2.1 Simple learning function

The simple learning function is that corrects the stop zone automatically for the next positioning operation when a discrepancy occurs between the target value and current position value upon completion of the positioning.

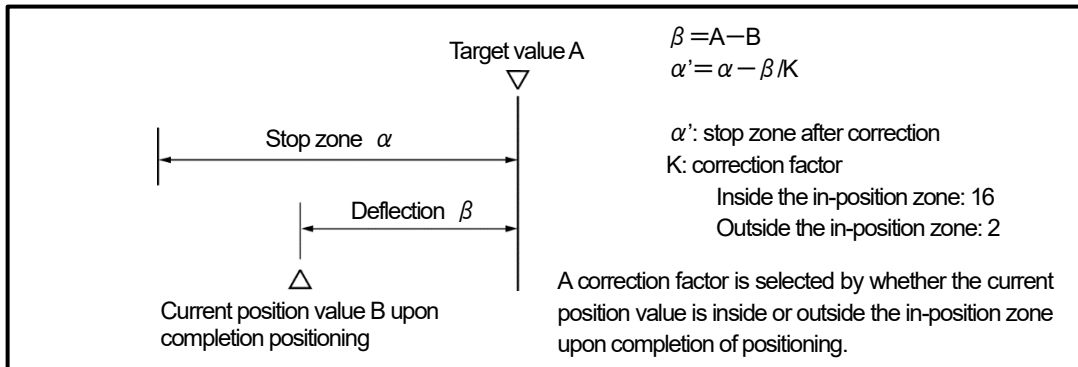

The corrected stop zone has two types (for FWD and RVS), and stored in the following areas.

A stop position that is used for the positioning is stored when the learning function is invalid.

Address	Contents
674(L) 675(H)	FWD stop zone after learning
676(L) 677(H)	RVS stop zone after learning

These areas are recovered in the buffer memory at next reapplying the power supply even if the power supply is turned OFF because they are stored in the internal memory (non-volatile memory).

### ● Advantage

#### (1) Improving the stop accuracy

The stop accuracy to the target value improves.

#### (2) Easy adjustment of the stop zone

- In the case of the simple learning function is invalid,

The stop zone must be designated with the predicted value when setting 'stop zone' of the parameter.

- In the case of the simple learning function is valid,

'Stop zone' is automatically corrected the proper value by repeating the operation by simply setting any values.

#### (3) No stop zone correction required due to the worn brake

The stop zone is automatically corrected even for the amount of brake slippage due to aged deterioration is increased.

#### (4) No stop zone correction required due to reciprocating operations

A load fluctuation might occur with reciprocating operations such as the machine's up /down motion.

The stop zone of FWD or RVS direction can be corrected when using the simple learning function.



### ● Initialization (FWD and RVS stop zones after learning)

The learning data (FWD and RVS stop zones after learning) is initialized in the following cases;

- The learning data is changed to the parameter's stop zone (Address 720 and 721) when the positioning format (Address 712) is changed.
  
- If the initialization command of 'stop zone after learning' (Address 393) is set to "1" when starting positioning, the positioning starts after the FWD stop zone after learning (Address 674 and 675) is changed to the value stored in the FWD stop zone (Address 383 and 384) and the RVS stop zone after learning (Address 676 and 677) is changed to the value stored in the RVS stop zone (Address 385 and 386).

Address	Item	Setting range	Default
393	Initialization command of 'stop zone after learning'	0: Not initialize the value. 1: Initialize the value.	0

The setting value is returned to the default value when the following operation is done because this area isn't backed up.

- Reset PLC CPU.
- Turn OFF the PLC power supply.

#### IMPORTANT

The simple learning function doesn't correct the stop zone when executing 'START from stop zone'.

## 9.3 Unidirectional Positioning

Positioning toward the target stop position is always executed from a single direction.

When positioning is required in the opposite direction, the target stop position will be overshoot, and positioning will then occur from the prescribed direction (U-turn is made).

The distance from the target value to a point of making U-turn is called 'overshoot amount'.

The unidirectional positioning format is useful in reducing stop position errors caused by the backlash.

For the unidirectional positioning function, the following parameter is set.

For the parameter setting procedures, refer to 'Chapter 5.3'.

Address	Item	Contents	Setting range	Default
713	Positioning direction	Select the positioning direction.	0: FWD direction 1: RVS direction	0
714(L) 715(H)	Overshoot amount	Designate the distance by which the target value is overshoot before a U-turn is made when executing the "unidirectional positioning".	0 to 999999	100

### ● Positioning direction (Address 713)

0: FWD direction

Operates as the following figure ① and ②.

1: RVS direction

Operates as the following figure ③ and ④.

### ● Overshoot amount (Address 714 and 715)

0: The unidirectional positioning isn't executed. (no overshooting)

1 to 999999: A distance indicated by 'L' is set in the following figure.

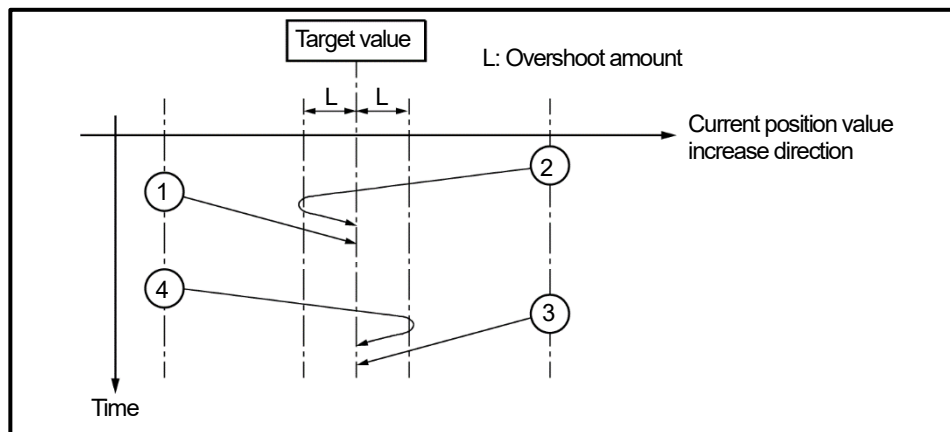

### IMPORTANT

The following warning occurs and the positioning isn't executed when the current position value is exceeded the permissible setting range after the overshooting even though the target value is set in the permissible setting range.

- Device X7 (error detection) is turned ON.
- Error 41 occurs.

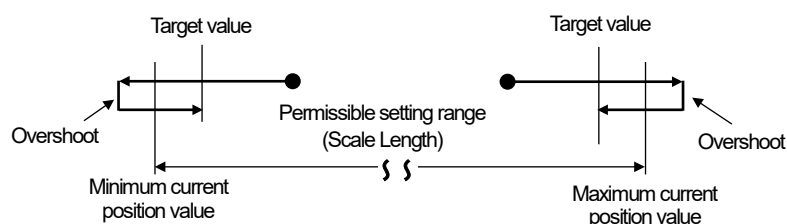

## 9.4 In-position Zone

The in-position zone is a reference distance uses to determine if the machine is stopped at the target value, and is a distance from the target value.

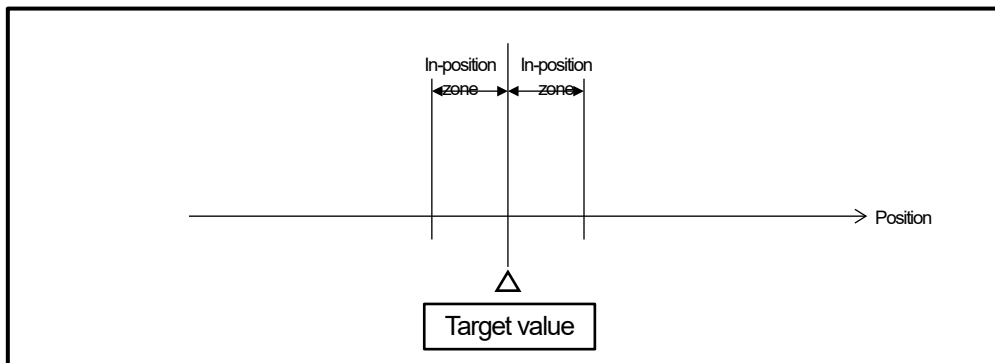

The in-position zone is designated in the following parameter.  
For the parameter setting procedures, refer to 'Chapter 5.3'.

Address	Item	Contents	Setting range	Default
722(L) 723(H)	In-position zone	Designate a reference distance used to determine if the machine is stopped at the target value.	0 to 999999	100

### ● In-position signal behavior

- (1) The in-position signal is turned ON when the current position value enters the in-position zone during online.
- (2) The in-position signal is turned OFF during offline.
- (3) The in-position signal is turned OFF when turning ON the power supply.
- (4) The in-position signal is turned ON when the current position value passes through the target value designated at a previous time during the JOG operation and enters the in-position zone.
- (5) The in-position signal is turned OFF while the 'positioning in progress' signal is ON except the time (t4) set to the positioning end detection timer (Address 731).

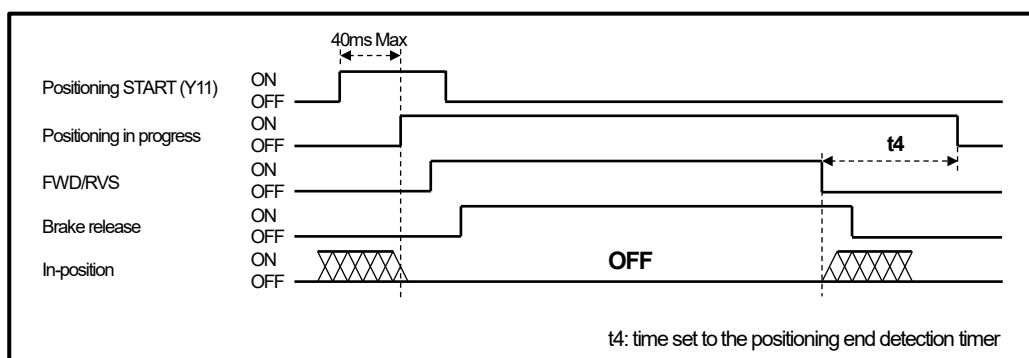

### 9.5 Upper / Lower Overtravel Detection Function

The upper and lower overtravel detection function is that monitors the current position value that exceeds the upper limit value or lower limit value.

The following warnings occur when exceeding the upper limit value.

- Device X2 (upper limit overtravel detection) is turned ON.
- Error 20 occurs.

The following warnings occur when exceeding the lower limit value.

- Device X3 (lower limit overtravel detection) is turned ON.
- Error 21 occurs.

However, the positioning is executed even though a warning occurs.

The upper/lower limit value is set by the following parameter.

For the parameter setting procedures, refer to 'Chapter 5.3'.

Address	Item	Contents	Setting range	Default
724(L) 725(H)	Upper limit value (+limit)	Designate the '+' direction limit value.	-99999 to 999999	999999
726(L) 727(H)	Lower limit value (-limit)	Designate the '-' direction limit value.	-999999 to 999999	-999999

#### (1) Warning clearing method

Turn ON (leading edge) Device Y16 (error reset).

## 9.6 'START from Stop Zone' Function

The 'START from stop zone' function is that executes the positioning from the stop zone.

For example, the positioning operation can be executed again if the machine stops at the outside of the in-position zone upon the completion of the positioning operation.

The 'START from stop zone' operates as below.

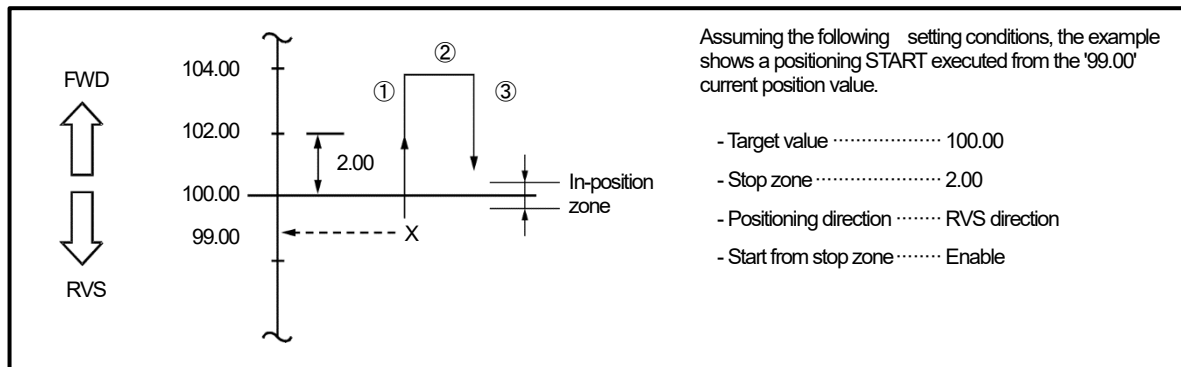

● **Operation explanation**

- ① Move the current position twice the distance of the stop zone, in the opposite direction to the parameter designated positioning direction (Address 713).
- ② Stop the movement at that position.
- ③ The positioning executes again toward the target value.

The 'START from stop zone' function is set in the following parameter.

For the parameter setting procedures, refer to 'Chapter 5.3'.

Address	Item	Contents	Setting range	Default
728	Start from stop zone	Designate whether the positioning is executed when the START position is already within the stop zone.	0: Disable 1: Enable	1

● **Operation conditions**

(1) **In the case of setting '0: disable' to 'START from stop zone (Address 728)' of the parameter,**

The positioning isn't executed within the stop zone.

The 'positioning in progress' signal will be turned ON in the following timing if the positioning START signal (Y11) turned ON.

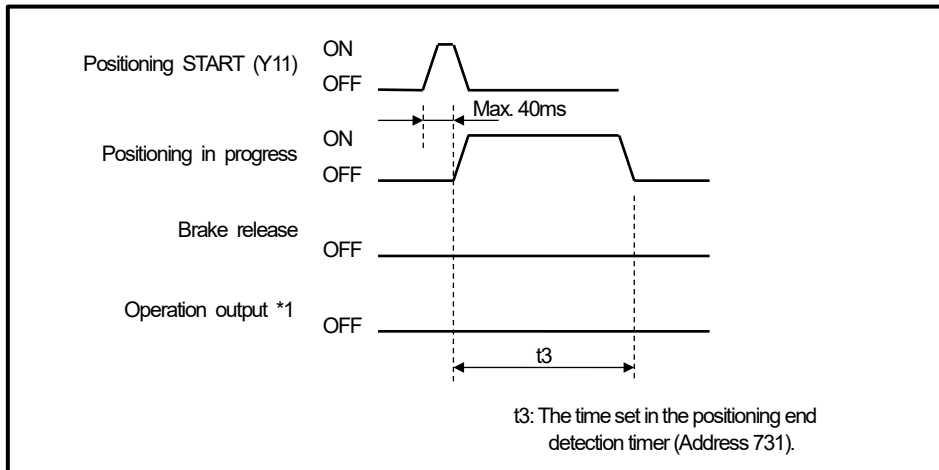

**\*1: Operation output**

The following signal is called 'operation output'.

FWD, RVS, speed command

(2) **In the case of the positioning starts from 'in-position' zone,**

The positioning isn't executed within the in-position zone.

The 'positioning in progress' signal will be turned ON in the following timing same as above (1) if the positioning START signal (Y11) turned ON.

**IMPORTANT**

The machine moves to the position twice the distance of the stop zone when the 'START from Stop Zone' is executed.

The following warnings occur and the positioning isn't executed when this position exceeds the permissible setting range.

- Device Y7 (error detection) is turned ON.
- Error 41 occurs.

## 9. POSITIONING FUNCTION (ACCELERATION/DECELERATION CONTROL)

MELSEC-Q

### 9.7 Positioning Pattern Data Setting

The positioning pattern data is set for executing the acceleration/deceleration control.

This area can be written to at any time by the TO instruction, but the setting applies only when the positioning START signal (Y11) is turned ON while online.

<b>IMPORTANT</b>
<p>The setting value is returned to the default when the following operation is done because this area isn't backed up.</p> <p>Control the setting value from the host controller's program.</p> <ul style="list-style-type: none"> <li>- Reset PLC CPU.</li> <li>- Turn the PLC power OFF.</li> </ul>

#### 9.7.1 Positioning pattern lists

Address	Item	Contents	Setting range	Default
367(L) 368(H)	Maximum speed (Vmax)	The machine's operation speed is designated when the speed command is 100%.	1 to 999999 (scale value/s)	999999
369	Speed limit	Designate the upper limit value of the speed command.	0 to 100 (%)	0
370(L) 371(H)	Maximum speed reach timer (t3)	Set the time (acceleration time) until that the speed command reaches 100%.	0 to 99999 (ms)	99999
372	Bias speed when positioning starts (Vb)	Designate the initial speed of the positioning operation.	0 to 100 (%)	0
373(L) 374(H)	Speed command ON delay timer (t2)	Designate the delay period until the outputting the speed command and FWD/RVS signal after accepting the input of the positioning START signal (Y11).	1 to 99999 (ms)	100
375(L) 376(H)	Brake release ON delay timer (t1)	Designate the delay period until turning the brake release signal ON after accepting the input of the positioning START signal (Y11).	1 to 99999 (ms)	100
377(L) 378(H)	Deceleration timer (T)	Designate the deceleration period that the speed command decreases from 100% to 0%.	1 to 99999 (ms)	100
379(L) 380(H)	Brake release OFF zone (L1)	Set the distance that is from a position applied the brake to the target stop position (target value).	0 to 999999	999999
381(L) 382(H)	Creep zone (L2)	Designate the distance that is from a position switched the speed command with the creep speed (Vc) to the target stop position (target value).	0 to 999999	1000
383(L) 384(H)	FWD stop zone (L3)	Designate the distance that is from a position designated the speed command as 0% to the target stop position (target value) during FWD operation.	0 to 999999	100
385(L) 386(H)	RVS stop zone (L3)	Designate the distance that is from a position designated the speed command as 0% to the target stop position (target value) during RVS operation.	0 to 999999	100
387	Creep speed (Vc)	Designate the speed command value when the current position value enters the creep zone (L2).	0 to 100 (%)	5
388(L) 389(H)	Stop timer (Ts)	Designate the deceleration period that the speed command decreases from 100% to 0% when stopping by turning ON the positioning stop signal (Y12).	1 to 99999 (ms)	100
390	Deceleration end speed (Vs)	Designate the speed command value that ends deceleration control when stopping by turning ON the positioning stop signal (Y12).	0 to 100 (%)	0
391(L) 392(H)	Reverse delay time (Tr)	Designate the waiting time when unidirectional positioning or 'START from stop zone' executed, and the positioning direction is reversed.	0 to 99999 (ms) (0:Auto-detection)	0

# 9. POSITIONING FUNCTION (ACCELERATION/DECELERATION CONTROL)

MELSEC-Q

## 9.7.2 Contents of pattern data for the operation

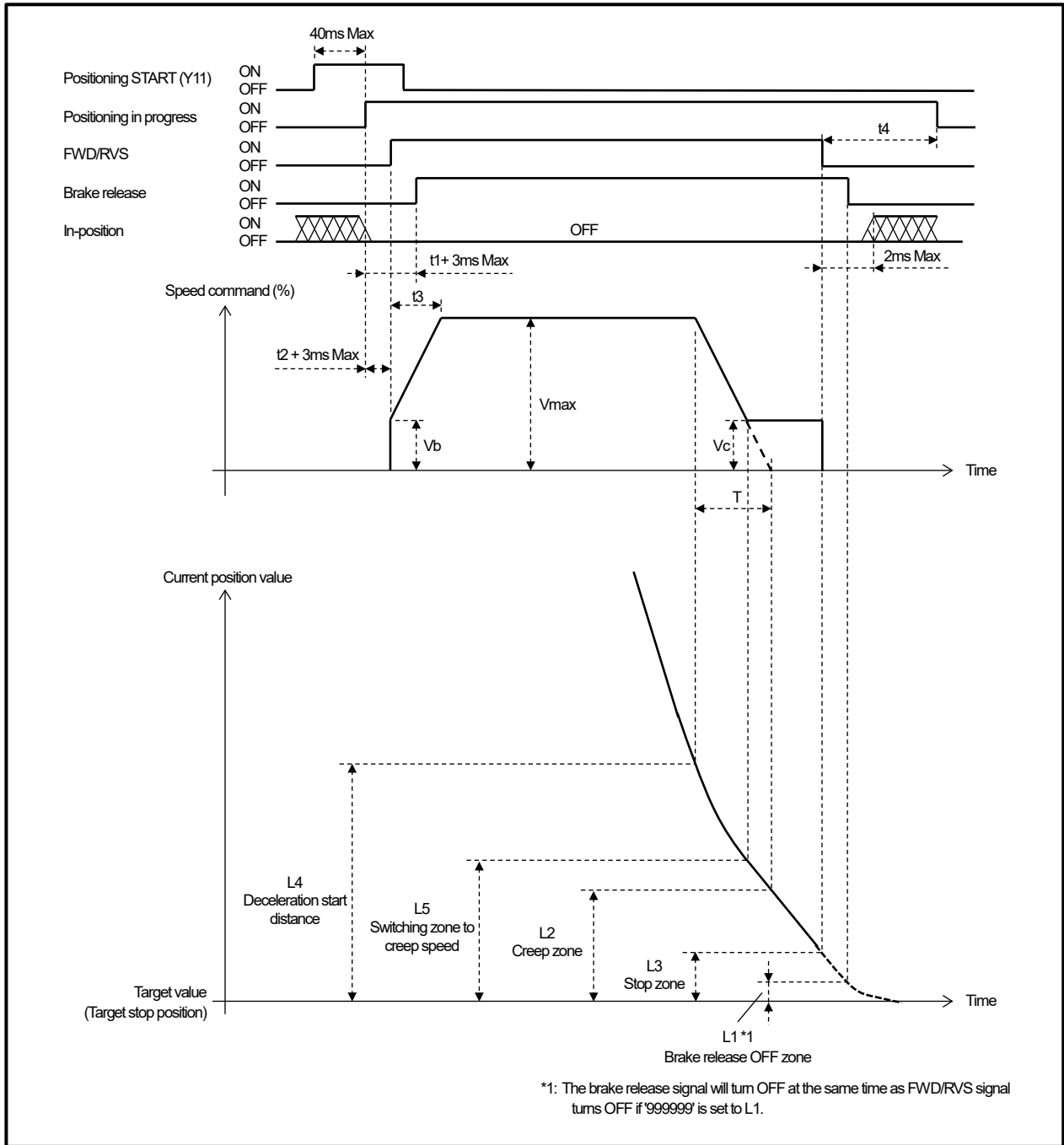



## (1) Vmax: Maximum speed (Address 367 and 368)

The machine's operation speed is designated when the speed command is 100%.  
 The setting is designated by a unit of the machine's operation speed. (scale value/s)

The speed will be calculated from the maximum frequency if an inverter is used.

### Example

- Travel amount of the ABSOCODER sensor per rotation: 10.0mm
- Motor rotation speed when outputting 100%: 1800r/min
- Speed reduction ratio: 1/2 (motor: 2-turn, ABSOCODER sensor: 1-turn)

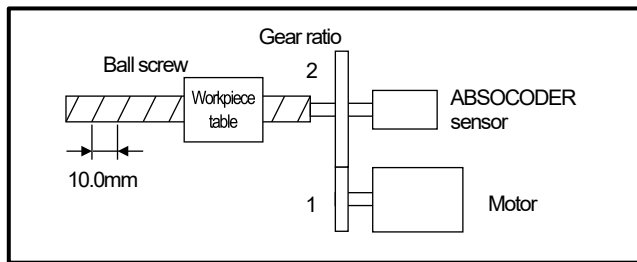

$$V_{max} = 10.0\text{mm} \times 1800\text{r/min} / 60\text{s} \times (1/2) = 150.0\text{mm/s}$$

## (2) Speed limit (Address 369)

Designate the upper limit value of the speed command.  
 The speed command is limited by this setting value.  
 The setting value is designated in the range from 0 to 100% (maximum speed as 100%).  
 The speed cannot be limited when executing the JOG operation.

### Example

- If you want to set as below;  
 Maximum speed (Vmax): 150.0mm/s, speed limit: 75.0mm/s  
 Speed limit = (75.0/150.0) x 100 = 50%

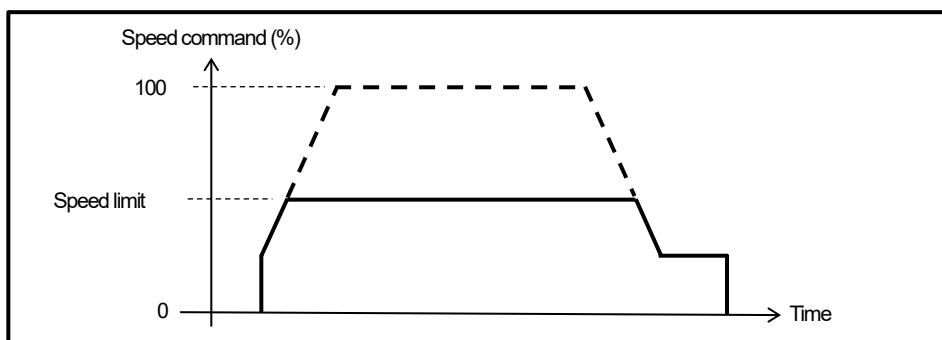

### IMPORTANT

For your safety, '0' is set when the power supply is turned ON for preventing starting the positioning operation.  
 Set it before starting the positioning operation.

### (3) $t_3$ : Maximum speed reach timer (Address 370 and 371)

Designate the time (acceleration time) until that the speed command reaches 100%. (Setting units: 1ms)

The speed command is not affected by the current position value change and reaches 100% in the time set this timer.

It might reach 100% before the designated time if the setting value is larger.

Specifically, the speed command might reach 100% before the designated time when the speed command is set approximately 26 seconds or more for changing 1%.

For the details, refer to the following figure.

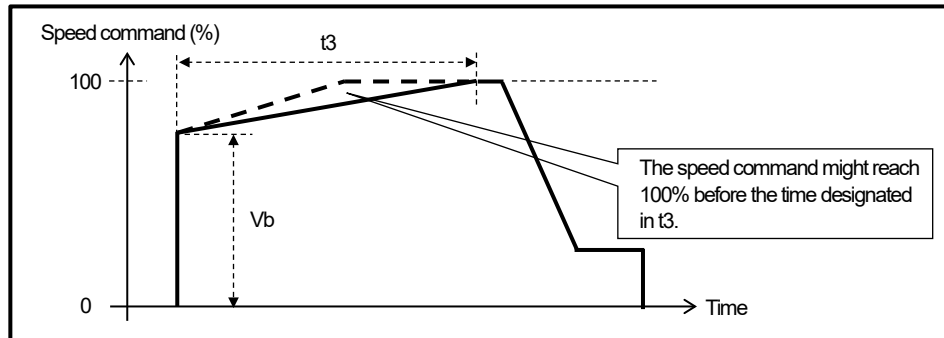

#### IMPORTANT

Beware that the speed command is output 100% just after positioning starts when setting to "0ms".

### (4) $V_b$ : Bias speed when positioning starts (Address 372)

Designate the initial speed of the positioning operation.

The setting value is designated in the range from 0 to 100% (maximum speed as 100%).

This pattern data should be set if stable torque is needed when starting the positioning.

The speed command is increased from 0% when setting to 0%.

### (5) $t_2$ : Speed command ON delay timer (Address 373 and 374)

Designate the delay period until the outputting the speed command and FWD/RVS signal after accepting the input of the positioning START signal (Y11). (Setting unit: 1ms)

$t_2$  is added maximum 3ms to the time designated this timer.

### (6) $t_1$ : Brake release ON delay timer (Address 375 and 376)

Designate the delay period until turning the brake release signal ON after accepting the input of the positioning START signal (Y11). (Setting unit: 1ms)

$t_1$  is added maximum 3ms to the time designated this timer.

The machine can be prevented to fall when starting the operation by setting  $t_1 > t_2$  if the machine is used on a vertical axis.

### (7) T: Deceleration timer (Address 377 and 378)

Designate the deceleration period that the speed command decreases from 100% to 0%. (Setting unit: 1ms)  
When decelerating, the speed command is output for the position decided by the maximum speed and deceleration timer.

Example: deceleration timer: 2000, maximum speed 1500mm/s,

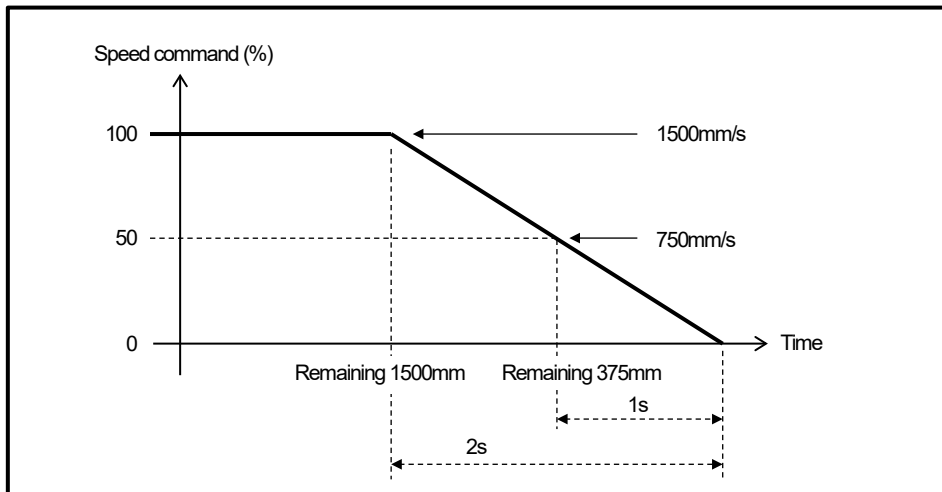

#### IMPORTANT

VS-QA62 outputs speed command value, but the actual deceleration curve is decided by the motor control device (inverter) performance and mechanical factors.

### (8) L1: Brake release OFF zone (Address 379 and 380)

Designate the distance that is from a position applied the brake to the target stop position (target value).  
The brake release signal will turn OFF at the same time as FWD/RVS signal turns OFF if '999999' (default value) is set to L1. Designate the value that is less than the FWD stop zone (Address 383 and 384) and RVS stop zone (Address 385 and 386) when setting the value except '999999'.

#### IMPORTANT

The positioning might not be completed when the brake release OFF zone value is larger than the FWD stop zone and RVS stop zone ones.

In this case, stop the positioning operation by turning the positioning STOP signal (Y12) ON.

Adjust the brake release OFF zone, FWD stop zone, and RVS stop zone before the operation when restarting the positioning operation.

### (9) L2: Creep zone (Address 381 and 382)

A distance is designated from the position that the speed command becomes 0% to the target stop position (target value).

Keeping the creep speed ( $V_c$ ) might be longer if the distance is long.

If the stop position dispersion is a lot, the stop position dispersion might be reduced when the creep zone (L2) be made large and the creep speed ( $V_c$ ) be made stable.

The speed command becomes 0% at the creep zone (L2) if the creep speed ( $V_c$ ) is 0%.

The switching zone to the creep speed (L5) is longer than the creep zone (L2) because the speed is switched to the creep speed before the speed command reaches 0% if the creep speed ( $V_c$ ) is larger than 0%.

Switching zone to the creep speed (L5) =  $L2 + T \times V_{max} \div 2000 \times (V_c \div 100)^2$

L2: Creep zone (units: scale value)

$V_{max}$ : Maximum speed (units: scale value/s)

$V_c$ : Creep speed (units: %)

T: Deceleration timer (units: ms)

### (10) L3: FWD/RVS stop zone (Address 383 to 386)

Designate the distance that is from a position designated the speed command as 0% to the target stop position (target value).

In the case of controlling an elevating device such as a crane, different stop zones can be set for FWD (upward) and RVS (downward).

### (11) $V_c$ : Creep speed (Address 387)

Designate the lower limit value of the speed command when decelerating the speed.

The setting value is designated in the range from 0 to 100% (maximum speed as 100%).

When the speed command value reaches the creep speed ( $V_c$ ) and the speed is automatically switched to the creep speed ( $V_c$ ), the creep speed ( $V_c$ ) is kept until the stop zone.

#### Example

Maximum speed ( $V_{max}$ ) setting: 1800r/min, creep speed: 90r/min

$V_c = (90/1800) \times 100 = 5\%$

### (12) t4: Positioning end detection timer (Address 731)

OFF delay period of the 'positioning in progress' signal

Designate a delay period from a point that FWD/RVS and speed command are all OFF to a point that the 'positioning in progress' signal is turned OFF (positioning is the end.).

When positioning in progress' signal is turned OFF, the brake release signal will be turned OFF forcibly if it is ON. t4 is designated in the following parameter (Address731).

For the parameter setting procedures, refer to 'Chapter 5.3'.

Address	Item	Contents	Setting range	Default
731	Positioning end detection timer	Designate the OFF delay period of the 'positioning in progress' signal upon completion of positioning.	0 to 9999 (Setting units: 10ms)	10

### (13) L4: Deceleration start distance

The deceleration starts when a distance to the target value is the deceleration start distance or less indicated below.

$$\text{Deceleration start distance (L4) (Scale)} = V_{\max} \times T \div 2000 + L2$$

L2: Creep zone (units: scale value)

Vmax: Maximum speed (units: scale value/s)

T: Deceleration timer (units: ms)

### (14) Speed command value during the deceleration

The speed command is output depending on a distance to the target value during the deceleration.

The speed command value during the deceleration is decided by the following formula.

$$\text{Absolute value speed command (\%)} = \sqrt{|L - L2|} \times \sqrt{2000 \div V_{\max} \div T} \times 100$$

L: Distance to the target value (units: scale value)

L2: Creep zone (units: scale value)

Vmax: Maximum speed (units: scale value/s)

T: Deceleration timer (units: ms)

However, the speed command is changed to the creep speed if its value is less than the creep speed.

## 9.7.3 Contents of the pattern data for the STOP

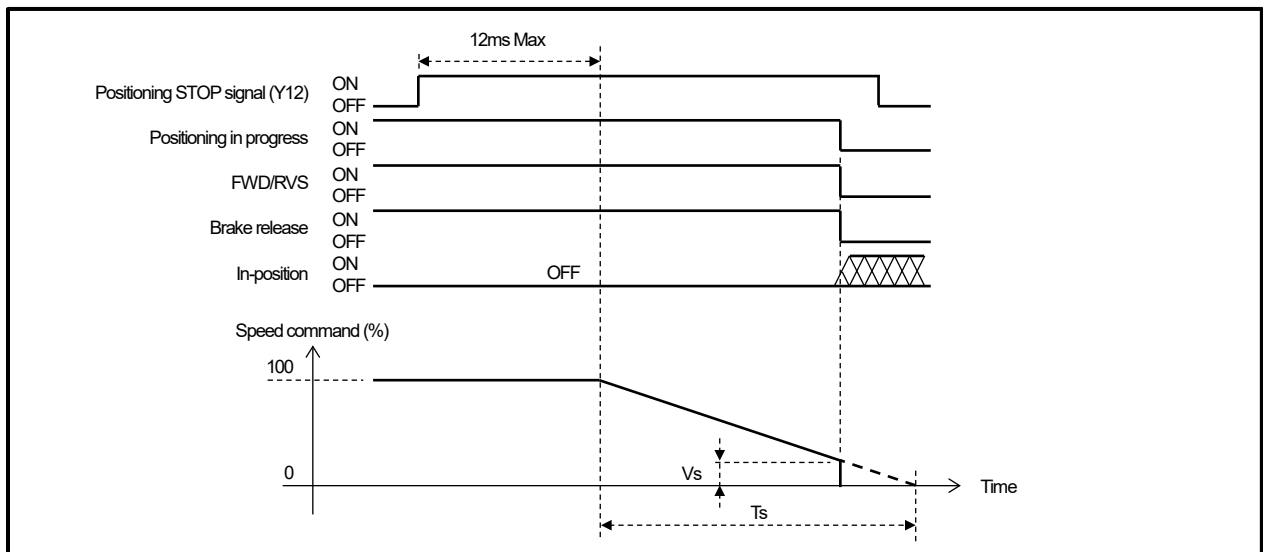

### (1) $T_s$ : STOP timer (Address 388 and 389)

The stop timer sets the deceleration time when stopping by turning ON the positioning stop signal (Y12).

The deceleration period is that the speed command is decelerated from 100% to 0%.

The speed command will be '0' without the deceleration if the STOP timer is designated to '0ms'.

The deceleration will be executed from the current speed command value if the speed is less than 100% when the positioning STOP signal (Y12) is turned ON.

The deceleration speed is the same as when decelerating from 100%, so the time until the speed command reaches 0% is faster.

#### IMPORTANT

In the case of setting the stop timer ( $T_s$ ) > deceleration timer ( $T$ ), the machine may stop after passing the target stop position (target value) depending on the timing when the positioning stop signal (Y12) is turned ON.

### (2) $V_s$ : Deceleration end speed (Address 390)

The deceleration end speed sets the speed command value that ends deceleration control when stopping by turning ON the positioning stop signal (Y12).

The setting value is designated in the range from 0 to 100% (maximum speed as 100%).

The deceleration control ends and the machine stops when the speed command value is this value or less.

9.7.4 Contents of the pattern data when overshooting

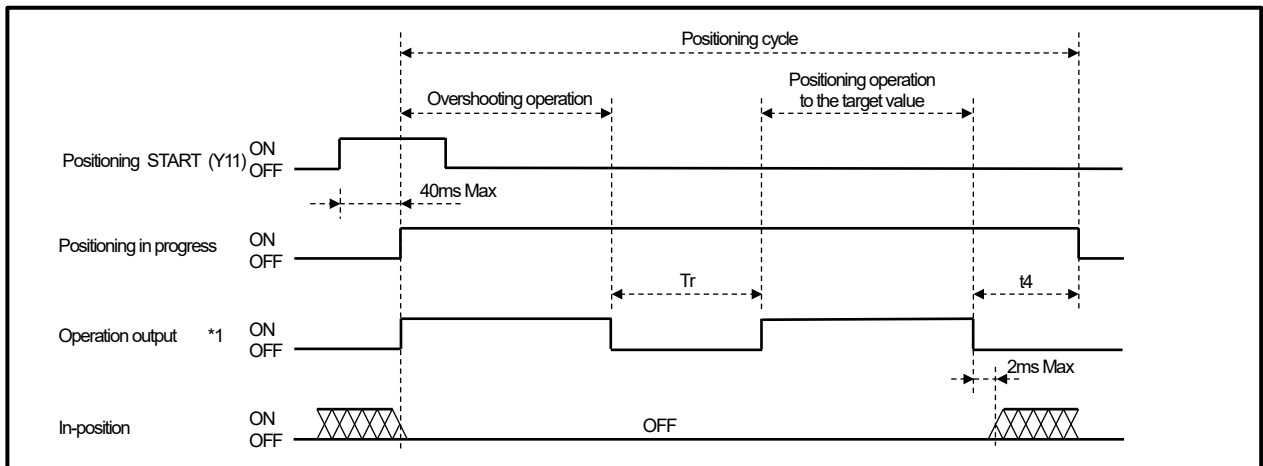

**\*1: Operation output**

The following signal is called 'operation output'.  
FWD, RVS, speed command

**(1)  $T_r$ : Reverse delay time (Address 391 and 392)**

Designate the waiting time when unidirectional positioning or 'START from stop zone' executed, and the positioning direction is reversed.

In the case of a reverse delay time '0', VS-QA62 compares the current position value (sensor binary value) per 100ms, and recognizes 'STOP' when the change amount plus/minus 2 digits or less.

After that, the machine moves in the reverse direction.

**(2)  $t_4$ : Positioning end detection timer (Address 731)**

OFF delay period of the 'positioning in progress' signal

Designate a delay period from a point that FWD/RVS and speed command are all OFF to a point that the 'positioning in progress' signal is turned OFF (positioning is the end.).

$t_4$  is designated in the following parameter (Address731).

For the parameter setting procedures, refer to 'Chapter 5.3'.

Address	Item	Contents	Setting range	Default
731	Positioning end detection timer	Designate the OFF delay period of the 'positioning in progress' signal upon completion of positioning.	0 to 9999 (Setting units: 10ms)	10

### 9.8 Analog Voltage Output Function (Speed Command)

The analog voltage output function is that the position or speed is output as the voltage from the external I/O connector (13 and 26 pins).

This chapter explains the method that outputs the speed command for the acceleration/deceleration control.

#### 9.8.1 Parameter setting

Specify the following 5 items at parameters.

For the parameter setting procedures, refer to 'Chapter 5.3'.

Address	Item	Contents	Setting range	Default
751	Analog output data selection	Select the analog output data.	0: No output (Fixed at 0) 1: Absolute value speed command (0 to 100%) 2: Speed command (-100 to 100%) 3: Current speed 4: Current position (scale value)	0
752(L) 753(H)	Maximum output voltage (Vmax)	Designate the analog output maximum voltage.	Vmin to 10.00 [V]	1000
754(L) 755(H)	Minimum output voltage (Vmin)	Designate the analog output minimum voltage.	-10.00 to Vmax [V]	0
756(L) 757(H)	Maximum output value	Designate speed command value for outputting maximum voltage.	-999999 to 999999 (Setting unit: %)	100
758(L) 759(H)	Minimum output value	Designate speed command value for outputting minimum voltage.	-999999 to 999999 (Setting unit: %)	0



● Details of the parameter

① Selection of the analog output data (Address 751)

Select output contents of the analog voltage.

0: No output

The output is fixed at 0.

1: Absolute value speed command

The speed command is output 0 to 100%.

2: Speed command

The speed command is output -100 to 100%.

3: Current speed

The speed is output in a unit that is selected at the speed gate time (Address 749) of the parameter.

Refer to 'chapter 6.8.1'

4: Current position (scale value)

The current position value (scaling binary) is output.

**Point**

Select '1 or 2' when using for the speed command.

② Maximum output voltage (V max) (Address 752 and 753)

Designate the maximum value of the output voltage.

Setting range: V min to +10.00V

The voltage becomes this value when the output voltage exceeds the maximum output voltage.

③ Minimum output voltage (V min) (Address 754 and 755)

Designate the minimum value of the output voltage.

Setting range: -10.00V to V max

The voltage becomes this value when the output voltage is less than the minimum output voltage.

④ Maximum output value (Address 756 and 757)

'Speed command value' is designated for outputting maximum voltage.

A unit of the value is % when used with by the speed command.

The maximum voltage is output when the value selected at Address 751 reaches this setting value. Refer to 'chapter 9.8.2'

Setting range: 999999 to 999999

⑤ Minimum output value (Address 758 and 759)

'Speed command value' is designated for outputting minimum voltage.

A unit of the value is % when used with by the speed command.

The minimum voltage is output when the value selected at Address 751 reaches this setting value. Refer to 'chapter 9.8.2'

Setting value: -999999 to 999999

## 9.8.2 Setting example

● When [Minimum Output Value] < [Maximum Output Value]

This is the output example in the following conditions.

- Speed command: -100 to +100%
- Output voltage range: -8.00V to +8.00V

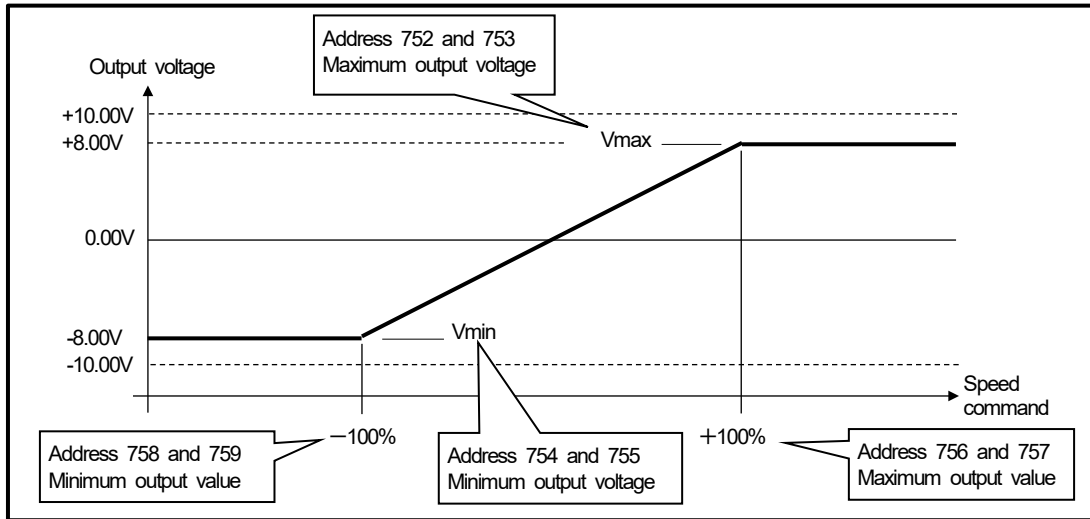

● When [Minimum output value] > [Maximum output value]

This is the output example in the following conditions.

- Speed command: -100 to +100%
- Output voltage range: +8.00V to -8.00V

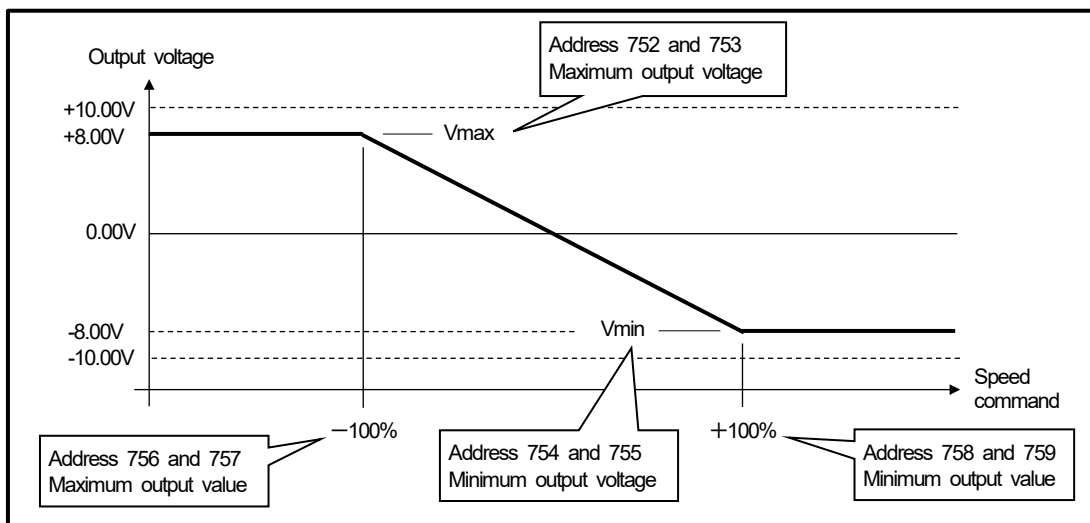

## 9.9 Positioning Operation

The positioning operation starts when turning ON (leading edge) the positioning START signal (Y11) after setting the positioning pattern data (Address 367 to 392) and the target value (Address 10 and 11).

The FWD JOG signal (Y13) and RVS JOG signal (Y14) aren't accepted during the positioning operation.

Turn ON the positioning STOP signal (Y12) when canceling the operation.

### ● Operation conditions

- ① The status is online (Y10 is ON).
- ② The positioning STOP signal (Y12) isn't turned ON.
- ③ The operation error signal isn't turned ON.
- ④ No sensor error occurs (error code 22).
- ⑤ Not in JOG operation

### 9.9.1 Procedure for the positioning operation

The procedures for the positioning operation are indicated below.

#### ● Procedure

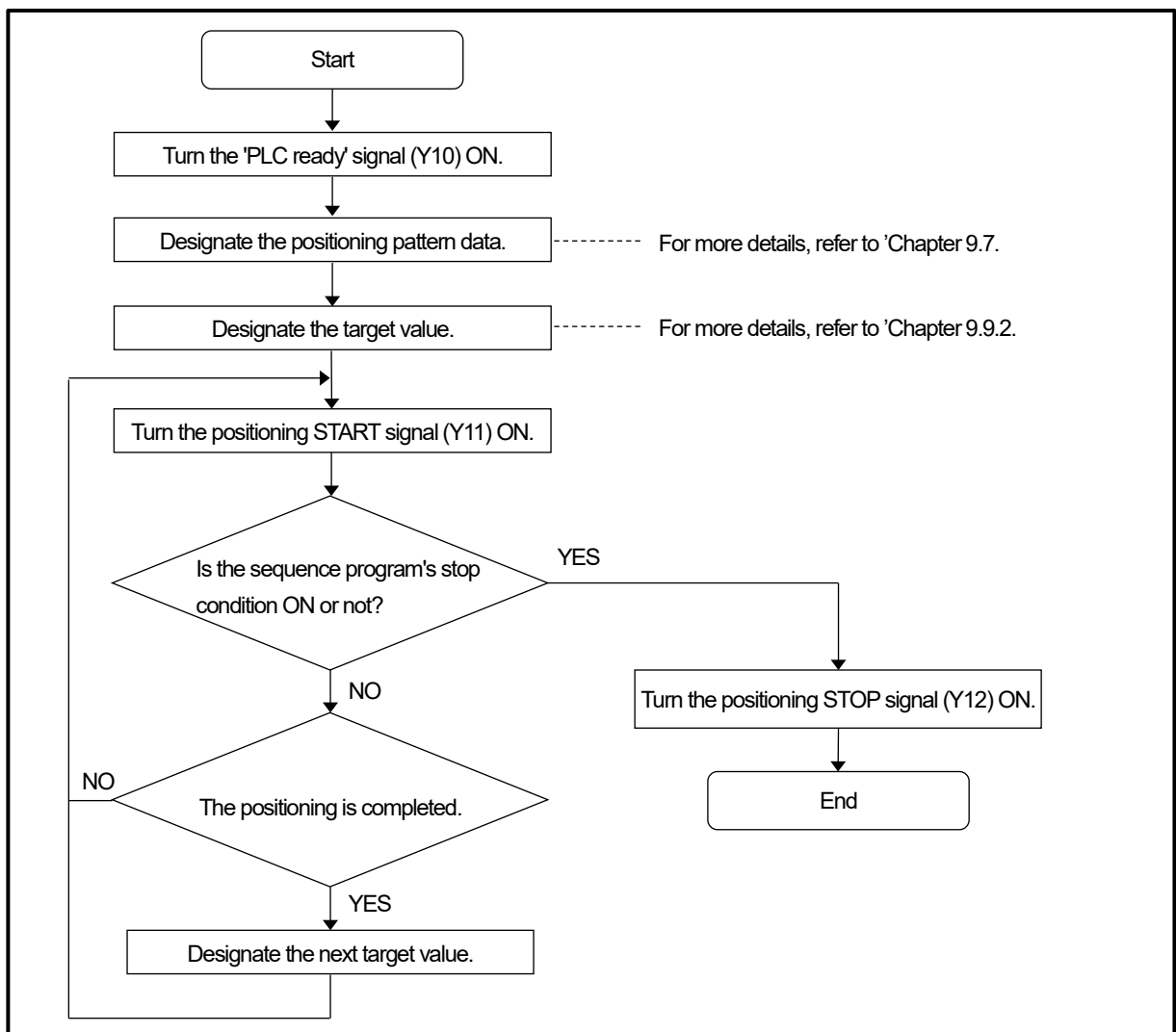

### 9.9.2 Positioning target stop position setting

The positioning target stop position (Address 10 and 11) designates the target value for the positioning operation. This area can be written to at any time by the TO instruction, but the setting applies only when the positioning START signal (Y11) is turned ON while online.

Address	Item	Contents	Setting range	Default
10(L) 11(H)	Target stop position setting data (scaling binary)	Designate the target value for the positioning operation.	Minimum current position value to [minimum current position value + scale length -1]	0

(1) The setting value is written as a scaling binary value.

(2) The permissible setting range is as follows:

[Minimum current position value] to [Minimum current position value + scale length -1].

(3) The following warnings occur if the value that is out of the permissible setting range is set.

- Device X7 (error detection) is turned ON.
- Error 41 occurs.

Moreover, warnings also occur in the followings;

- In the case of the positioning overshoots and the current position value is exceeded the permissible setting range,  
For details, refer to 'Chapter 9.3'.
- In the case of the current position value is exceeding the permissible setting range when executing the 'start from the stop zone',  
For details, refer to 'Chapter 9.6'.

#### IMPORTANT

The positioning target isn't changed even if the positioning target stop position (target value) is changed during the positioning operation.

The setting is valid when the positioning START signal (Y11) is turned ON again after completing the positioning cycle ('positioning in progress' signal is OFF.).

## 9.9.3 Positioning output status area (Address 696)

This is the area that stores the positioning output signal status.  
 The positioning output signal is output to the bit as below figure.  
 '1' is stored when the positioning output signal is ON.

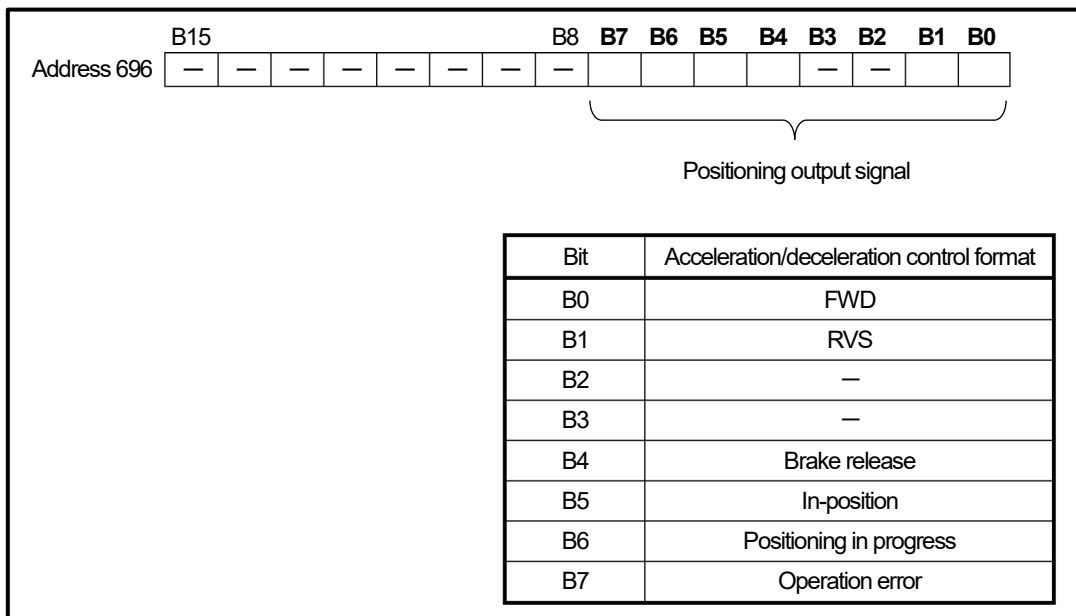

## 9.9.4 Speed command area

### Speed command (with sign) area (Address 697)

This area stores the speed command (with sign) value when positioning by the acceleration/deceleration control format.  
 The value is stored in the range between -100 to 100% in the binary value.  
 The value is '0' indicates the positioning stops.  
 'Negative (-)' value is stored as a complement of '2', and it means reversing.

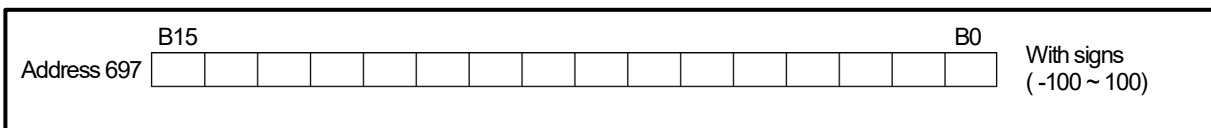

### Speed command (absolute value) area (Address 698)

This area stores the speed command (absolute value) value when positioning by the acceleration/deceleration control format.  
 The value is stored in the range between 0 to 100% in the binary value.  
 The value is '0' indicates the positioning stops.  
 In the reversing operation, the value is changed to a positive number (absolute number) and stored.

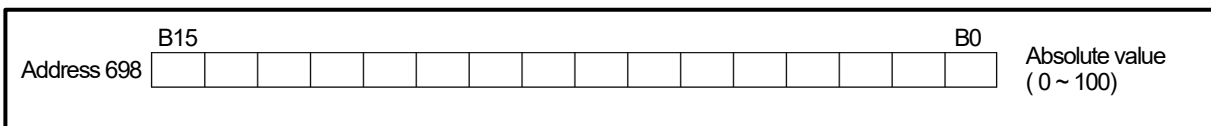

### 9.9.5 Current position preset during the positioning operation

The current position preset function is operative even when positioning is in progress. The resulting operation is explained below.

**(1) When the positioning direction is not changed as a result of the current position preset function:**

The positioning operation is not interrupted.

The positioning operation is controlled based on the current position value which is after the current position preset function is executed. Therefore, the speed command value might change significantly depending on the distance between this current position value and the target value.

**(2) When the positioning direction is reversed as a result of the current position preset function:**

The positioning operation will be stopped with deceleration, and after a 'stop detection' has occurred, the positioning operation will be automatically re-started based on the current position value which is after the current position preset function is executed.

After being re-started, positioning operation occurs in the normal manner. The overshooting operation and START from stop zone operation are executed depending on the stop position.

The deceleration method is the same as the positioning stop. For more details, refer to 'Chapter 9.7.3'.

**(3) When the positioning direction isn't changed and the current position value is within the stop zone as a result of the current position preset function:**

It is the same as the normal positioning operation.

In the case of the positioning operation other than the target value such as overshoot operation or 'START from stop zone' is in progress, the positioning starts toward the target position after passing the time set to the reverse delay time (Address 391 and 392).

In the case of the positioning operation to the target value is in progress, the positioning operation is ended after the time which is designated to the 'positioning end detection timer'(Address 731) has elapsed.

**(4) STOP recognition**

VS-QA62 compares the current position value (sensor binary value) per 100ms, and recognizes 'STOP' when the change amount becomes plus/minus 2 digits or less.

**(5) When prohibiting the current position preset during the positioning operation:**

Turn ON the following device signals by the sequence program.

- Current position preset 1 prohibit signal (Y17)
- Current position preset 2 prohibit signal (Y18)

However, the current position preset prohibit signal is valid only when selecting 'parameter format' or 'buffer memory format' for the current position preset function (Address 748).

### 9.10 JOG Operation

The JOG operation executes during turning the FWD or RVS JOG signal (Y13/Y14) ON.

The positioning START signal (Y11) isn't accepted during the JOG operation.

The operation stops when turning the FWD JOG signal (Y13) and RVS JOG signal (Y14) ON simultaneously.

#### ● Operation conditions

- ① The status is online (Y10 is ON).
- ② The operation error signal isn't ON
- ③ The 'positioning in progress' signal isn't ON.
- ④ No sensor error (error code 22)

#### ● JOG low-speed timer

The JOG low-speed timer designates the low-speed time during the JOG operation.

The operation output is switched from low-speed to high-speed after the setting time has elapsed during FWD or RVS JOG signal (Y13/Y14) continues ON.

The setting unit is 10ms.

The operation output becomes low-speed constantly if the time is designated to 9999 (99.99s).

The JOG low-speed timer is designated in the following parameter.

For the parameter setting procedures, refer to 'Chapter 5.3'.

Address	Item	Contents	Setting range	Default
732	JOG low-speed timer ( t )	Designate the low-speed operation period for the JOG operation.	0 to 9999 When '9999', 'Low-Speed' is always specified. (Setting units: 10ms)	9999

#### ● JOG speed setting

The JOG speed is designated the speed which is executed the JOG operation in the range of 0 to 100%.

The JOG speed is setting in the following parameter.

For the parameter setting procedures, refer to 'Chapter 5.3'.

Address	Item	Contents	Setting range	Default
760	JOG low-speed (V1)	Designate the low-speed operation speed during the JOG operation.	0 to 100 %	10
761	JOG high-speed (V2)	Designate the high-speed operation speed during the JOG operation.	0 to 100 %	10

● **Timing chart**

The timing chart for the JOG operation is shown below.

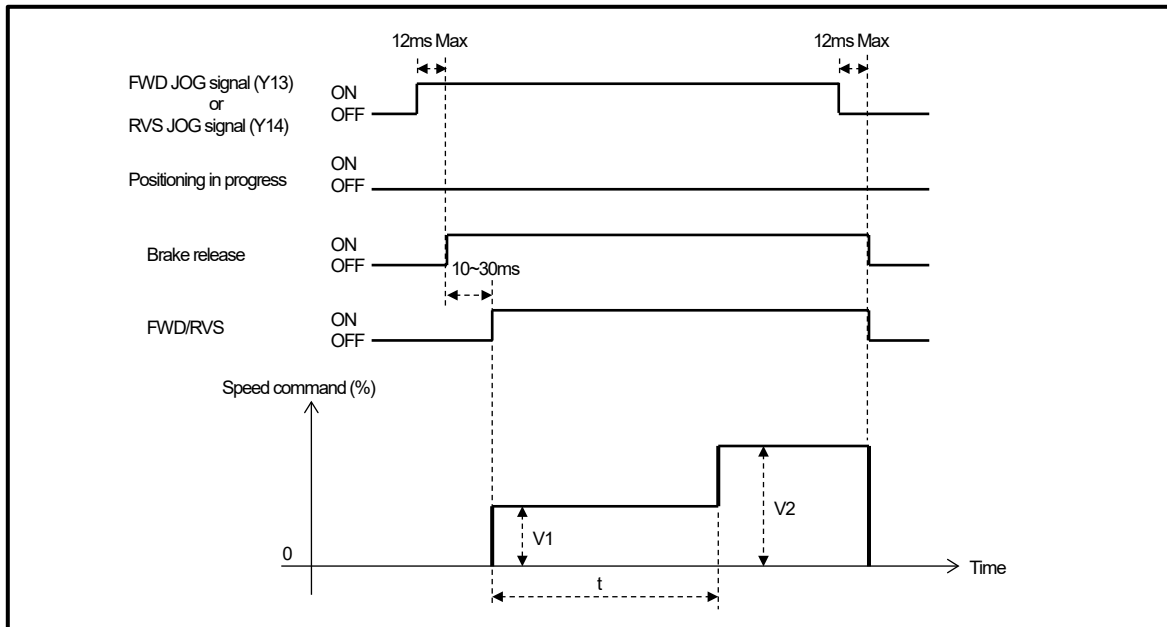

V1: Indicates the JOG operation at low speed.

The speed is set in JOG low-speed (Address 760).

V2: Indicates the JOG operation at high speed.

The speed is set in JOG high-speed (Address 761).

T: Indicates the operation time at a low speed from starting the JOG operation.

Time is set in the JOG low-speed timer of the parameter (Address 732).

The speed command is switched from low-speed to high-speed after the setting time has elapsed during the JOG signal continues ON.



## 9.11 Operation Error

When the following errors are detected during a JOG or positioning operation, the operation will automatically be stopped (operation output OFF). At this time, an operation error signal\*1 is output (turn ON).

The JOG or positioning operation cannot be executed while the operation error signal is ON.

- (1) Sensor error (error code 22)
- (2) Motion detection error (error code 42)
- (3) Motion direction error (error code 43)
- (4) Detection range over (error code 44) \*2
- (5) Learning data error (error code 25) \*2

**Point**

\*1: The operation error signal is output to the following 4 locations.

- Device XF
- 7 in the upper row of the panel monitor LEDs
- 8-pin of the external I/O connector
- Bit 7 of the buffer memory address 696

\*2: Errors don't occur during the JOG operation.

VS-QA62 continues the operation even when other errors except the above errors occur.

Turn the device Y12 (positioning STOP signal) ON when you desire to stop.

● **Error clearing method**

Turn ON (leading edge) Device Y16 (error reset).

Turns OFF the operation error signal.

**(1) Sensor error (error code 22)**

A sensor error occurs in the following cases;

- The ABSOCODEDR sensor isn't connected.
- The cable for ABSOCODER is disconnected.
- The position detection circuit inside of VS-QA62 has a failure.

**(2) Motion detection error (error code 42)**

The 'motion detection error' checks whether the current position value is changed while outputting the operation output signal.

This error occurs when the current position value isn't changed.

VS-QA62 compares the current position value (sensor binary value) per 0.5s, and recognizes 'STOP' when the change amount becomes plus/minus 2 digits or less.

A 'non-detection period' can be set with considering the response delay of the external motor drive circuits.

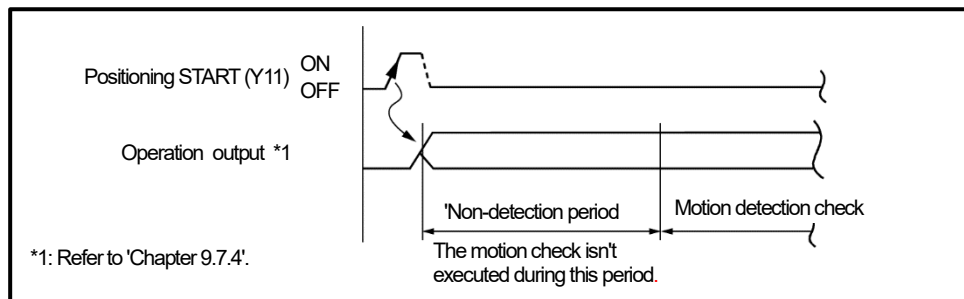

The 'non-detection period' is designated in the following parameter.

This error doesn't occur because the motion check isn't executed when setting '0'.

For the parameter setting procedures, refer to 'Chapter 5.3'.

Address	Item	Contents	Setting range	Default
729	Motion non-detection timer	Designate the period from the point when positioning is started until the point when the 'motion detection check' starts.	0 to 9999 (Setting units: 10ms)	1000

### (3) Motion direction error (error code 43)

The 'motion direction error' check whether the current position value changes in the direction opposite to the direction command of the operation output.

This error occurs when the current position value is changed in the opposite direction.

VS-QA62 compares the current position value (sensor binary value) change per 0.5s, and recognizes error when the change amount to the opposite direction becomes plus/minus 3 digits or more.

A 'non-detection period' can be set with considering the response delay of the external motor drive circuits.

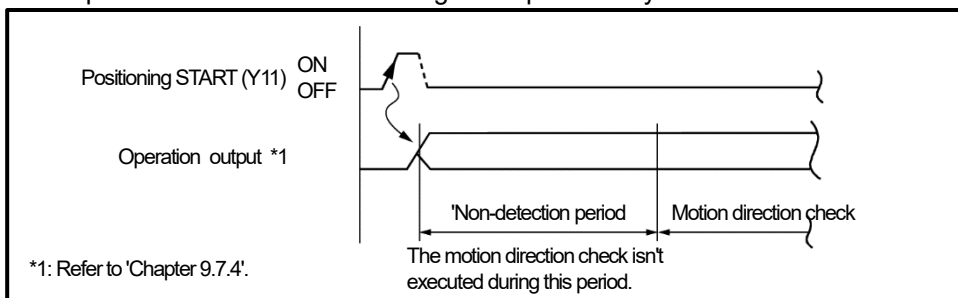

The 'non-detection period' is designated in the following parameter.

This error doesn't occur because the motion check isn't executed when setting '0'.

For the parameter setting procedures, refer to 'Chapter 5.3'.

Address	Item	Contents	Setting range	Default
730	Motion misdirection non-detection timer	Designate the period from the point when positioning is started until the point when the 'motion direction check' starts.	0 to 9999 (Setting units: 10ms)	1000

### (4) Detection range over (error code 44)

The detection range over occurs when the current position value exceeds the detection range during the positioning.

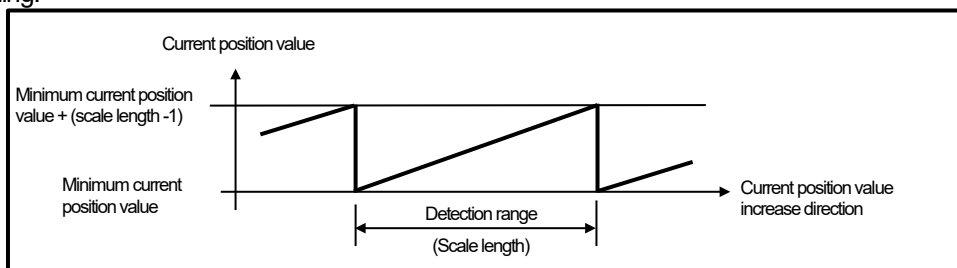

In the condition that the current position exceeds the detection range, VS-QA62 controls that the current position moves to the opposite direction more if the positioning operation to the target value same as before is executed.

Move back the current position value to the detection range using JOG operation etc. after clearing the error if the current position value exceeds the detection range, and restart the operation.

#### IMPORTANT

Do not use around both ends of the detection range when the positioning operation. Moreover, install the mechanical type of the limit switches for multiple safety measures.

### (5) Learning data error (error code 25)

The learning data error occurs when the corrected stop zone by the simple learning function is exceeds the low-speed zone.

The 'stop zone after learning (Addresses 674 to 677)' becomes the same value as the low-speed zone when a learning data error occurs.



## 10. TROUBLESHOOTING

The causes and corrective actions for errors that may occur during VS-QA62 operation are described in this chapter.

### 10.1 Error Code List

The VS-QA62 error codes are described below.

When VS-QA62 detects an error, the corresponding error code is stored in address 7 of the buffer memory.

At that time the 'error detection' signal (X7) is turned ON.

At the same time, the operation status display area will show the lower 6 lit or blinking.

Listed below are the possible error codes (with each hexadecimal code in parenthesis).

1/5

Error name	Lower 6 LED	Error code	Description	When detected	Countermeasure	
'Buffer memory writing disabled' errors	Blinks	10,11 (HA, HB)	The writing was done in the writing disable area of the buffer memory by the TO instruction.	Current position value (scaling binary) area (Address 0, 1)	During online status	Revise the sequence program so that writing is not attempted in a 'writing disabled' area of the buffer memory.
		12,13 (HC, HD)		Current position value (sensor binary) area (Address 2, 3)		
		14 (HE)		Limit switch output status area (Address 4)		
		15 (HF)		Limit switch writing command answerback area (Address 5)		
		16 (H10)		Input status area (Address 6)		
		17 (H11)		Error code area (Address 7)		
		18 (H12)	The writing was done in the writing disable area of the buffer memory (Address 668 to 677, 696 to 698, and 701) by the TO instruction.	Speed output area (Address 668, 669)		
				Hold current position (scaling binary) area (Address 670, 671)		
				Hold current position (sensor binary) area (Address 672, 673)		
				FWD stop zone after learning area (Address 674, 675)		
				RVS stop zone after learning area (Address 676, 677)		
				Positioning output status area (Address 696)		
Speed command (with sign) area (Address 697)						
Speed command (absolute value) area (Address 698)						
Data memory flag answerback area (Address 701)						
Upper limit overtravel	Blinks	20 (H14)	VS-QA62 detected an 'upper limit overtravel' condition. X2 switches ON.	During online status	- Move the machine back within the 'lower-limit to upper-limit' range.	
Lower limit overtravel	Blinks	21 (H15)	VS-QA62 detected a 'lower limit overtravel' condition. X3 switches ON.		- Revise the positioning pattern data. - Revise the positioning parameter settings. - Revise the 'lower-limit/upper-limit' settings.	
Sensor error	Lit on	22 (H16)	VS-QA62 detected a sensor error. The causes may be as follows: - ABSOCODER sensor is disconnected. - ABSOCODER cable is severed. - ABSOCODER sensor failure - Malfunction at VS-QA62's internal position detection circuit  X4 switches ON.	Always	- Connect the ABSOCODER sensor. - Check the electrical condition of the ABSOCODER cable. - Replace the ABSOCODER sensor. - In case the problem seems to be caused by a malfunction at VS-QA62's internal position detection circuit, please contact your service representative.	

Error name	Lower 6 LED	Error code	Description	When detected	Countermeasure
Excessive correction amount	Blinks	23 (H17)	VS-QA62 detected the 'excessive correction amount'. The causes may be as follows: - Misalignment between ABSOCODER sensor's detected position and actual position, caused by machine slippage, backlash, etc. - Deviation in the position where 'current position preset' input signal is received - Incorrect 'permissible correction amount' parameter setting  X5 switches ON.	During the 'current position preset' operation	- Adjust the machine. - Revise the 'permissible correction amount' parameter.
Excessive current position change	Blinks	24 (H18)	VS-QA62 detected an 'excessive current position change'. The causes may be as follows: - ABSOCODER sensor's rotation (travel) speed is too fast. - Incorrect 'permissible current position change amount' parameter. - ABSOCODER cable is severed. - ABSOCODER sensor failure - Malfunction at VS-QA62's internal position detection circuit  X6 switches ON.	Always	- Check the ABSOCODER sensor's rotation (travel) speed. - Revise the 'permissible current position change amount' parameter. - Check the electrical condition of the ABSOCODER cable. - Replace the ABSOCODER sensor. - In case the problem seems to be caused by a malfunction at VS-QA62's internal position detection circuit, please contact your service representative.
Learning data error	Blinks	25 (H19)	The stop zone corrected by the simple learning function has exceeded the low-speed zone when controlling in the speed switching format (2-speed/3-speed control).  The stop zone corrected by the simple learning function has exceeded the creep zone when controlling in the acceleration/deceleration control format.	When positioning is completed	- Check the 'operation output' connections. - Adjust the machine. - Revise the positioning parameter.
Limit switch setting error	Blinks	1014 (H3F6)   1364 (H554)	The data set to the limit switch output ON/OFF data setting area is incorrect.  The error code is the relevant buffer memory address +1000.	When Limit switch writing command was executed.	Designate the correct data.
Unacceptance of the start	Blinks	40 (H28)	START input inoperative. The causes may be as follows: - Sensor error (22) is occurring. - An offline status exists. - 'Operation error' (XF) is ON. - JOG operation is in progress. - Positioning STOP signal (Y12) is ON.	During 'positioning START' input (Except for during positioning operation)	Check each of the probable causes, and make the necessary corrections.
Target value error	Blinks	41 (H29)	The positioning target value data is outside the detection range.  At the time of overshooting or executing the start within the stop zone, the stop position is outside the detection range.	When positioning starts	- Designate the correct target value for the positioning operation. - Revise the scale length, the minimum current position value, the overshoot amount, and the stop zone settings.
Motion detection error	Blinks	42 (H2A)	VS-QA62 detected a 'motion detection error' (no motion) during an 'operation output' is ON.	During positioning, or JOG operation	- Check the 'operation output' connections. - Check the motor control device. - Revise the 'motion non-detection timer' parameter.
Motion direction error	Blinks	43 (H2B)	VS-QA62 detected a 'motion direction error' (motion in opposite direction) during an 'operation output' is ON.		- Check the 'operation output' connections. - Check the motor control device. - Revise the 'motion misdirection non-detection timer' parameter.
Detection range over	Blinks	44 (H2C)	The current position value exceeds the detection range during the positioning.	During positioning	- Revise the positioning pattern data. - Revise the scale length and the minimum current position value.
Preset value error	Blinks	50 (H32)	A 'current position preset' was attempted to a point outside the detection range.	During the 'current position preset' operation	- Revise the 'current position preset' value. - Revise the scale length and the minimum current position value.

Error name	Lower 6 LED	Error code	Description	When detected	Countermeasure	
Data error	Lit on	60 (H3C)	VS-QA62 detected the initial setting or the parameter data error.	When turning the power ON	- Correct the initial setting. - Correct the parameter setting.	
		69 (H45)	VS-QA62 detected a current position setting error.	When turning the power ON	Re-designate the current position value.	
Buffer memory data errors	Blinks	1367 (H557)	Activated when incorrect data writing (using the sequence program 'TO' instruction) is attempted in a 'writing enabled' area of the buffer memory. (Addresses 367 to 393 and 678 to 693)  The error code is the relevant buffer memory address +1000.	Maximum speed area	When positioning starts	Revise the sequence program so as not to write the incorrect data in the buffer memory.
		1369 (H559)		Speed limit area		
		1370 (H55A)		Maximum speed reach timer area		
		1372 (H55C)		Bias speed when positioning starts area		
		1373 (H55D)		Speed command ON delay timer area		
		1375 (H55F)		Brake release ON delay timer area		
		1377 (H561)		Deceleration timer area		
		1379 (H563)		Brake release OFF zone area		
		1381 (H565)		Creep zone area		
		1383 (H567)		FWD stop zone area		
		1385 (H569)		RVS stop zone area		
		1387 (H56B)		Creep speed area		
		1388 (H56C)		Stop timer area		
		1390 (H56E)		Deceleration end speed area		
		1391 (H56F)		Reverse delay time area		
		1393 (H571)		Initialization command of 'stop zone after learning'		
		1678 (H68E)		Speed limit area		
		1680 (H690)		Medium-speed zone area		
		1682 (H692)		Low-speed zone area		
		1684 (H694)		FWD stop zone area		
1686 (H696)	RVS stop zone area					
1688 (H698)	In-position zone area					
1690 (H69A)	Current position preset value 1 area	When operating the 'current position preset'				
1692 (H69C)	Current position preset value 2 area					

Error name	Lower 6 LED	Error code	Description	When detected	Countermeasure
Buffer memory data errors	Blinks	1702 (H6A6)	Sensor rotation direction area	When writing the parameter data	Revise the sequence program so as not to write the incorrect data in the buffer memory.
		1704 (H6A8)	Scale length area		
		1706 (H6AA)	Minimum current position value area		
		1708 (H6AC)	Current position value area		
		1710 (H6AE)	Current position change command area		
		1711 (H6AF)	Output signal selection area		
		1712 (H6B0)	Positioning format area		
		1713 (H6B1)	Positioning direction area		
		1714 (H6B2)	Overshoot amount area		
		1716 (H6B4)	Medium-speed zone area		
		1718 (H6B6)	Low-speed zone area		
		1720 (H6B8)	Stop zone area		
		1722 (H6BA)	In-position zone area		
		1724 (H6BC)	Upper limit value area		
		1726 (H6BE)	Lower limit value area		
		1728 (H6C0)	Start from stop zone area		
		1729 (H6C1)	Motion non-detection timer		
		1730 (H6C2)	'Motion misdirection non-detection timer' area		
		1731 (H6C3)	Positioning end detection timer area		
		1732 (H6C4)	JOG low-speed timer area		
1733 (H6C5)	Offline channel output status area				
1734 (H6C6)	Pulse output count setting value area				
1736 (H6C8)	Permissible current position change amount area				

Error name	Lower 6 LED	Error code	Description	When detected	Countermeasure	
Buffer memory data errors	Blinks	1738 (H6CA)	Activated when incorrect data writing (using the sequence program 'TO' instruction) is attempted in a 'writing enabled' area of the buffer memory. (Addresses 702 to 761)  The error code is the relevant buffer memory address +1000.	Permissible correction amount area	When writing the parameter data	Revise the sequence program so as not to write the incorrect data in the buffer memory.
		1740 (H6CC)		FWD current position preset value 1 area		
		1742 (H6CE)		RVS current position preset value 1 area		
		1744 (H6D0)		FWD current position preset value 2 area		
		1746 (H6D2)		RVS current position preset value 2 area		
		1748 (H6D4)		Current position preset function area		
		1749 (H6D5)		Speed gate time area		
		1750 (H6D6)		Speed sampling time area		
		1751 (H6D7)		Analog output data selection area		
		1752 (H6D8)		Maximum output voltage area		
		1754 (H6DA)		Minimum output voltage area		
		1756 (H6DC)		Maximum output value area		
		1758 (H6DE)		Minimum output value area		
		1760 (H6E0)		JOG low-speed area		
1761 (H6E1)	JOG high-speed area					
CPU error	Fast blinks	—	Error detected at programmable controller CPU.	Always	Check the programmable controller system.	



## ● Error monitor

The lower row '0 to 4' of LED display area is turned ON according to the error kinds.

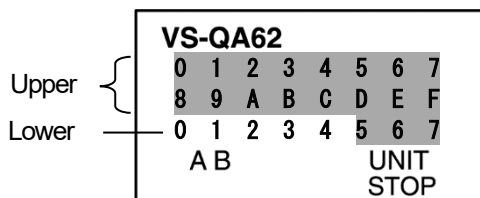

●: LED is ON

Error code	Error name	Lower LED				
		0	1	2	3	4
10 to 18	'Buffer memory writing disabled' errors	●				
20	Upper limit overtravel		●			
21	Lower limit overtravel	●	●			
22	Sensor error			●		
23	Excessive correction amount	●		●		
24	Excessive current position change		●	●		
25	Learning data error	●	●	●		
40	Unacceptance of the start				●	
41	Target value error	●			●	
42	Motion detection error		●		●	
43	Motion direction error	●	●		●	
44	Detection range over			●	●	
50	Preset value error	●		●	●	
60, 69	Data error		●	●	●	
1014 to 1364	Limit switch setting error	●	●	●	●	
1367 to 1761	Buffer memory data errors					●

## ● Error clearing method

- (1) The error code stored in buffer memory (Address 7) is overwritten when a new error occurs.
- (2) The error status will be automatically cleared when the PLC CPU reset status is canceled.
- (3) The error code stored in the buffer memory will not be cleared (returned to '0') simply by correcting the cause of the error.  
Clear the error code in the buffer memory by the following operations;
  - Device Y16 (error reset) is turned ON (leading edge).
  - Reset the PLC CPU.
  - Turn OFF the PLC power supply.

## 10.2 Troubleshooting Flowchart

The VS-QA62 troubleshooting procedure is explained below.

For CPU module related problems, consult the manual for the CPU module in question.

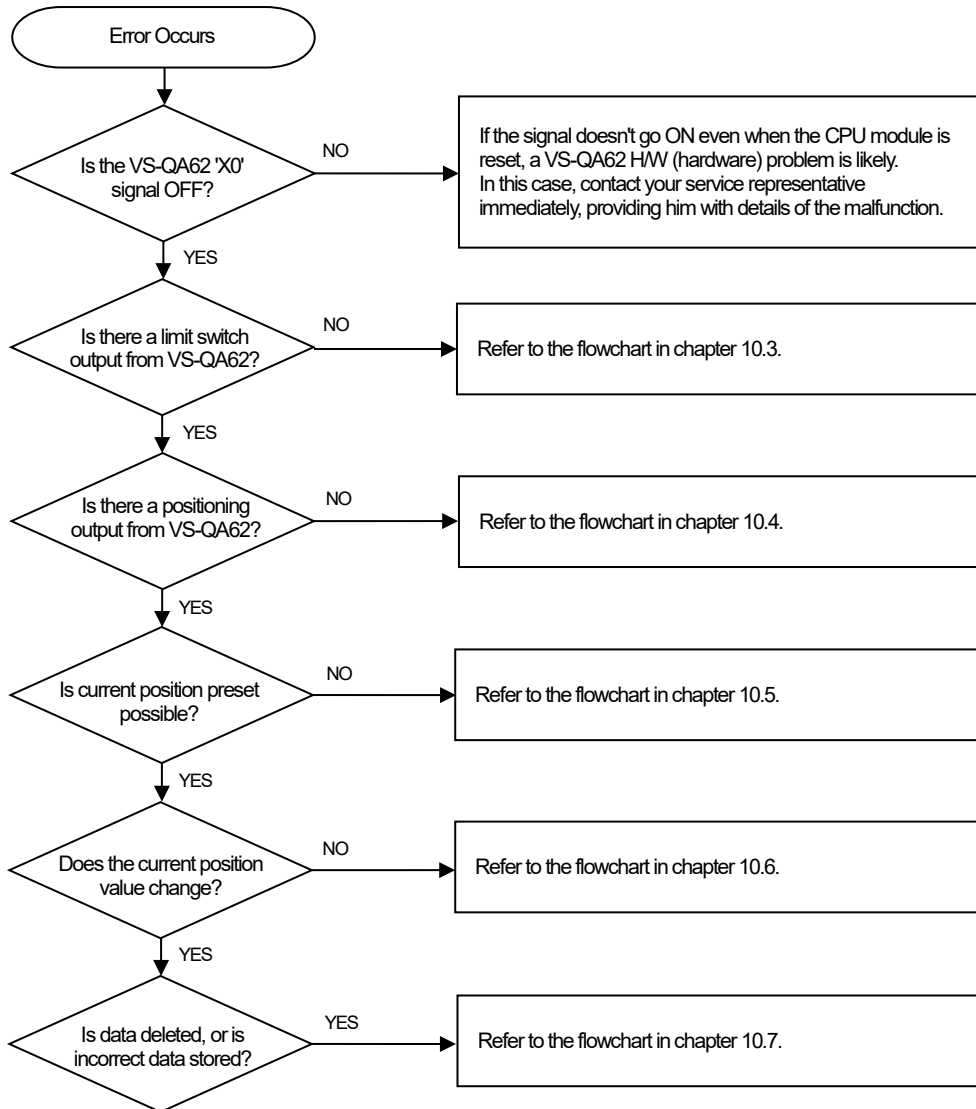

10.3 Flowchart for No Limit Switch output from VS-QA62

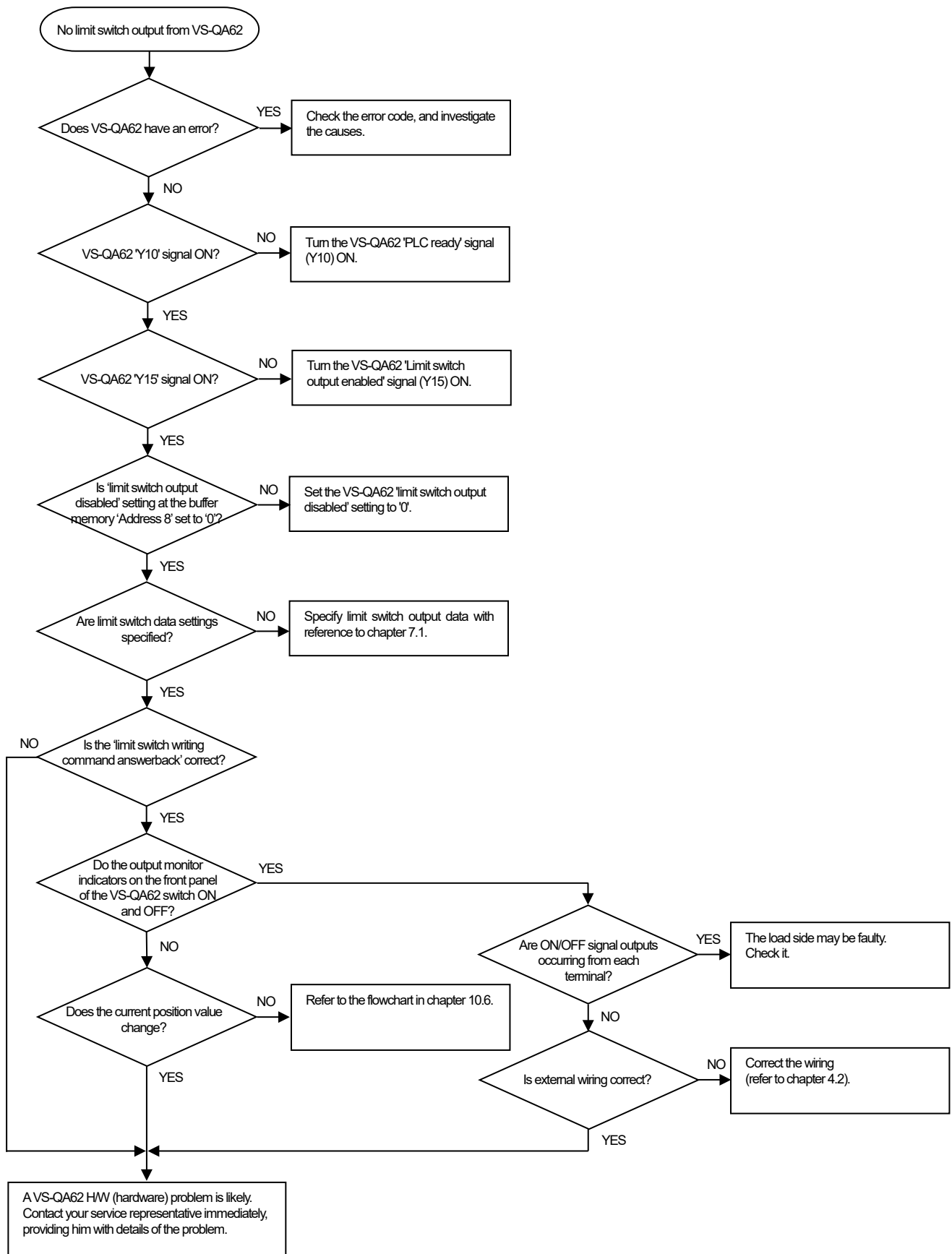

## 10.4 Flowchart for No Positioning Output from VS-QA62

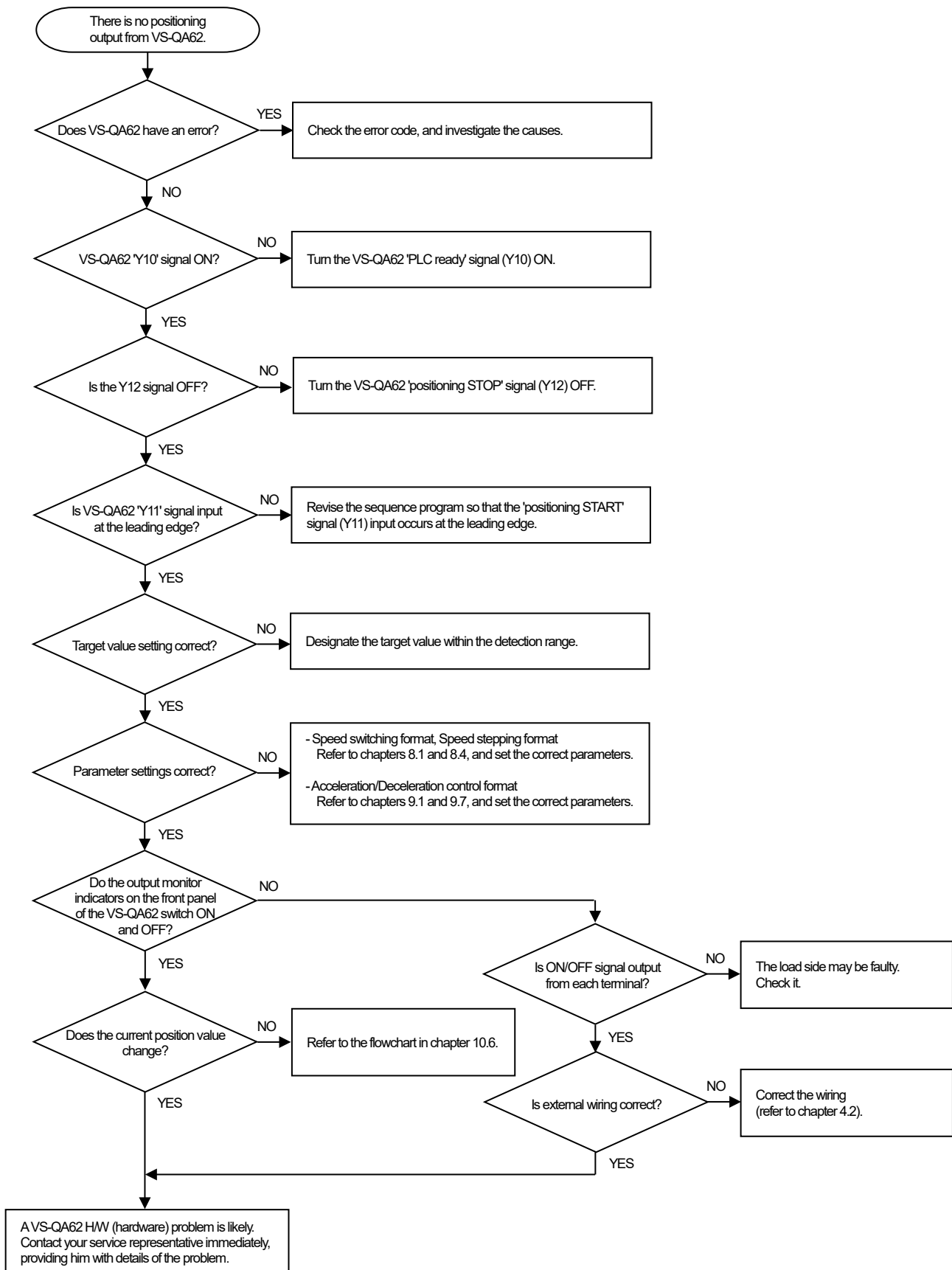

10.5 Flowchart when Current Position Preset is Impossible

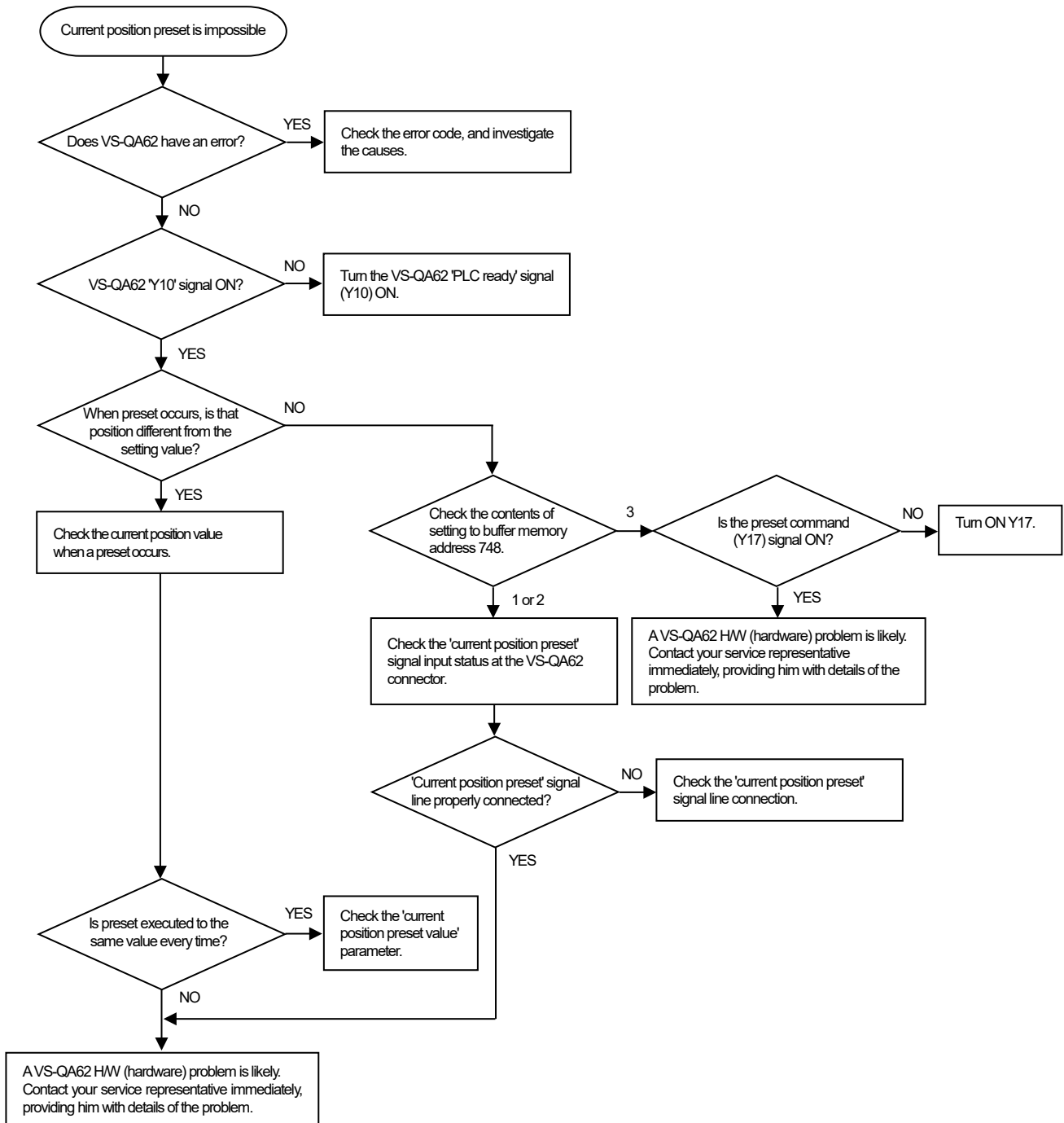

## 10.6 Flowchart when Current Position Value doesn't Change

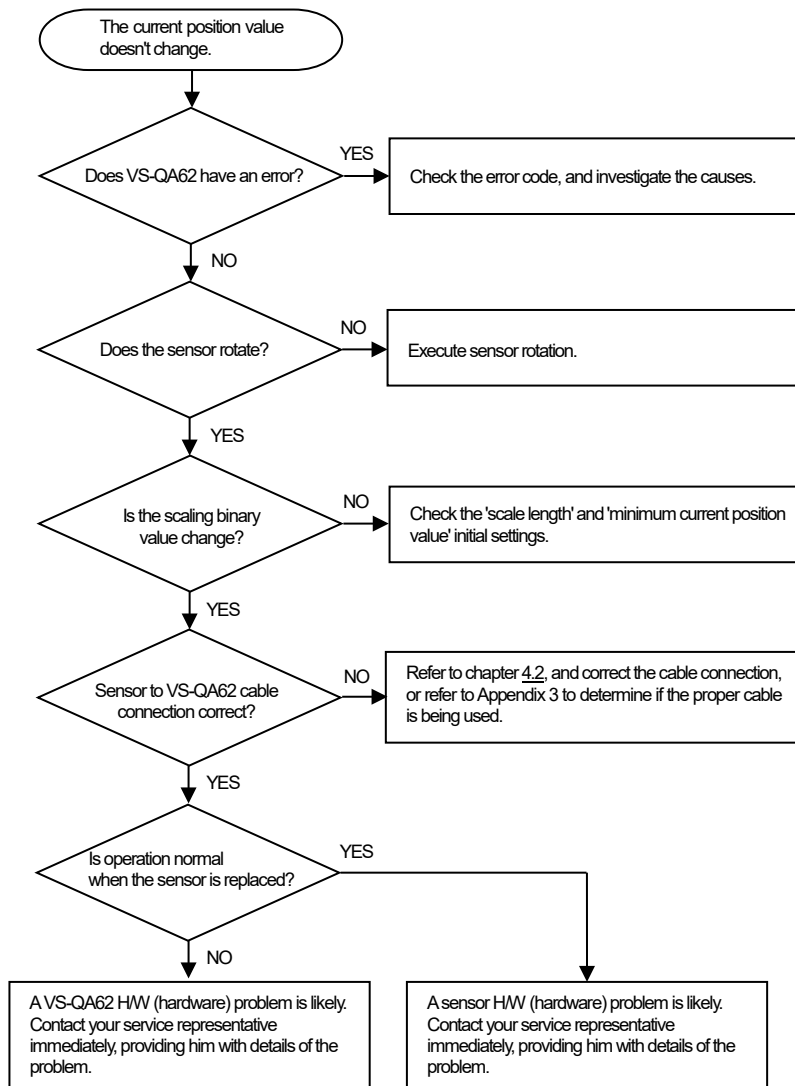

10.7 Flowchart when Stored Data is Lost, or when Erroneous Data is Stored

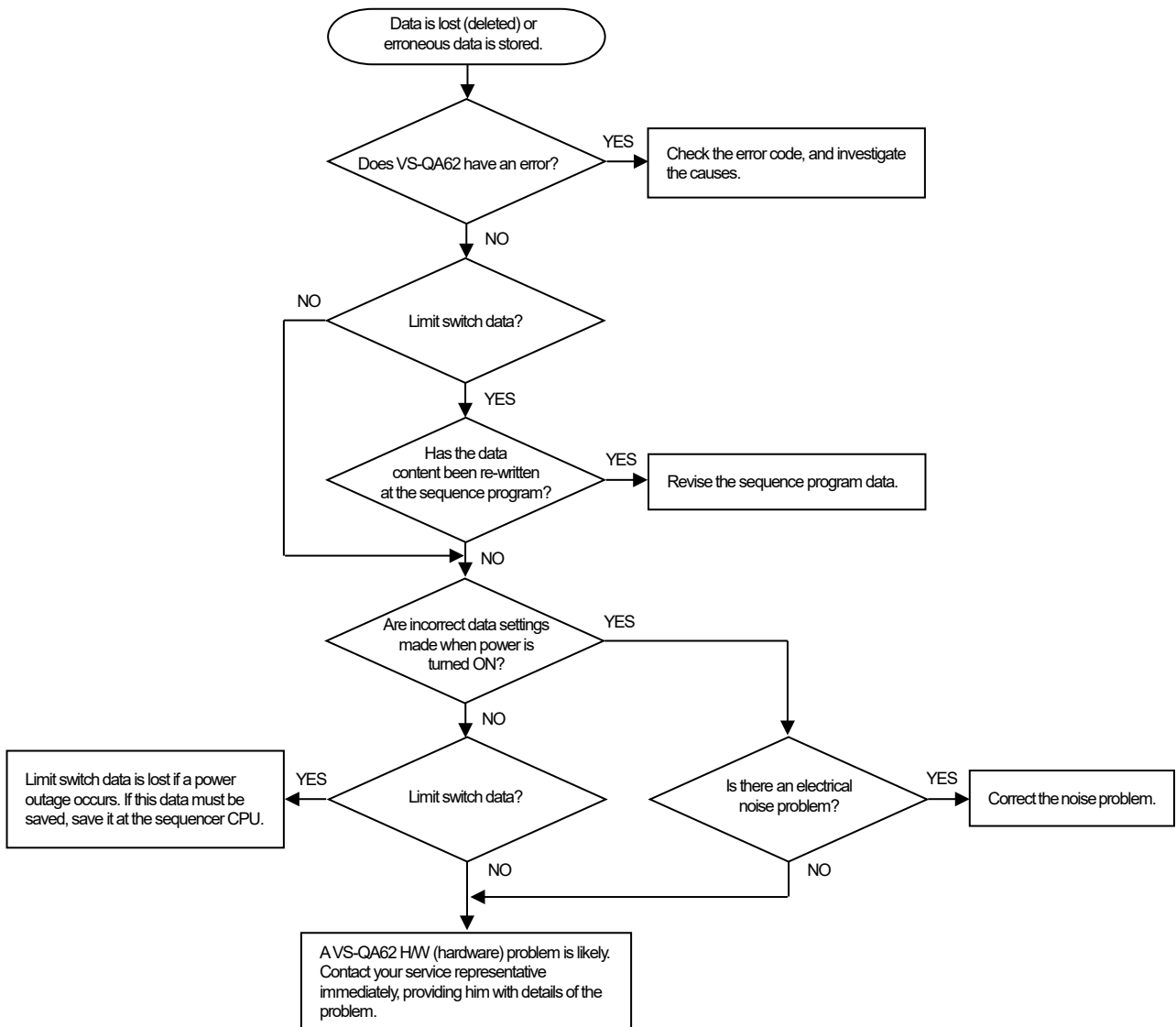

APPENDIX 1 VS-QA62 AND CABLE OUTER DIMENSIONS

Appendix 1.1 VS-QA62

●VS-QA62

Units: mm

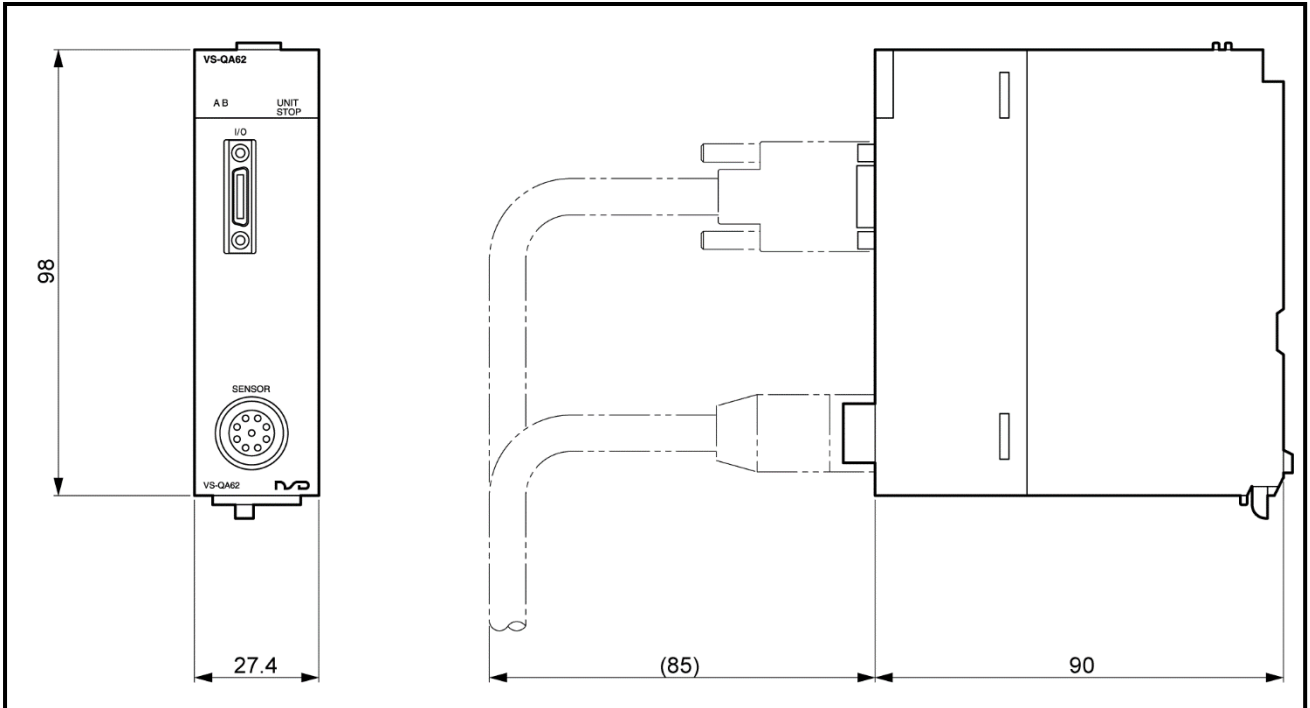



Appendix 1.2 External I/O Cable (VS-CQA62)

●VS-CQA62

Units: mm

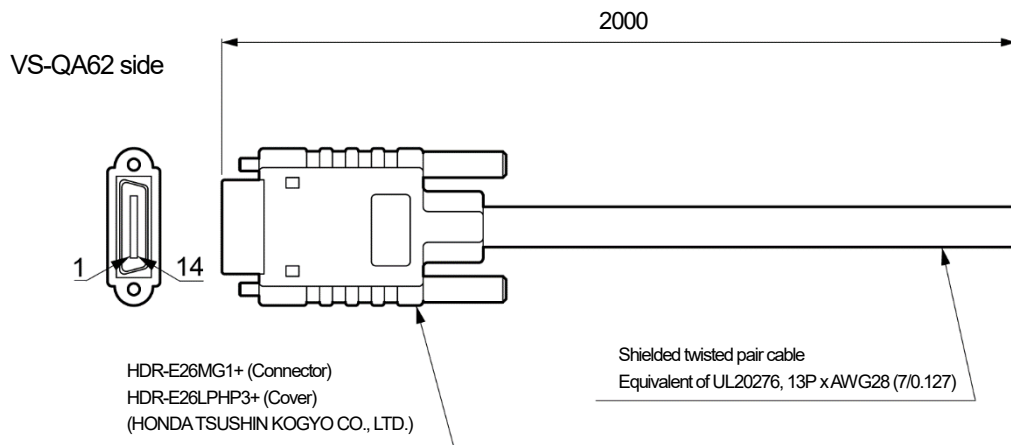

VS-QA62 side

Signal name	Pin No.	Shield	Color	Dot mark color
CH.0 *1	1	Shield	Orange ■	
CH.1 *1	2	Shield	Orange □	
CH.2 *1	3	Shield	Gray ■	
CH.3 *1	4	Shield	Gray □	
CH.4 *1	5	Shield	White ■	
CH.5 *1	6	Shield	White □	
CH.6 *1	7	Shield	Yellow ■	
CH.7 *1	8	Shield	Yellow □	
Current position preset input 1	9	Shield	Pink ■	
Current position preset input 2	10	Shield	Pink □	
Control input common	11	Shield	Orange ■■	
Control input common	12	Shield	Orange □□	
Analog output +	13	Shield	Gray ■■	
SG (pulse output)	14	Shield	Gray □□	
5V (pulse output)	15	Shield	White ■■	
Not used	16	Shield	White □□	
Not used	17	Shield	White □□	
B- (pulse output)	18	Shield	Yellow ■■	
B+ (pulse output)	19	Shield	Yellow □□	
A- (pulse output)	20	Shield	Pink ■■	
A+ (pulse output)	21	Shield	Pink □□	
Not used	22	Shield	Orange ■■■	
Not used	23	Shield	Orange □□□	
Control output common	24	Shield	Gray ■■■	
Control output common	25	Shield	Gray □□□	
Analog output -	26	Shield	White □□□	
SLD	CASE	Shield	White ■■■	

Dot mark color  
 ■ : Red □ : Blue

\*1: This figure indicates the signal name of the limit switch output function, but the signal changes to the positioning function according to the setting of the buffer memory address 711.

For details of signal names, refer to 'Chapter 3.4.2'.

Appendix 1.3 Cable for the Upgrading (VS-CQA62-R01)

●VS-CQA62-R01

Units: mm

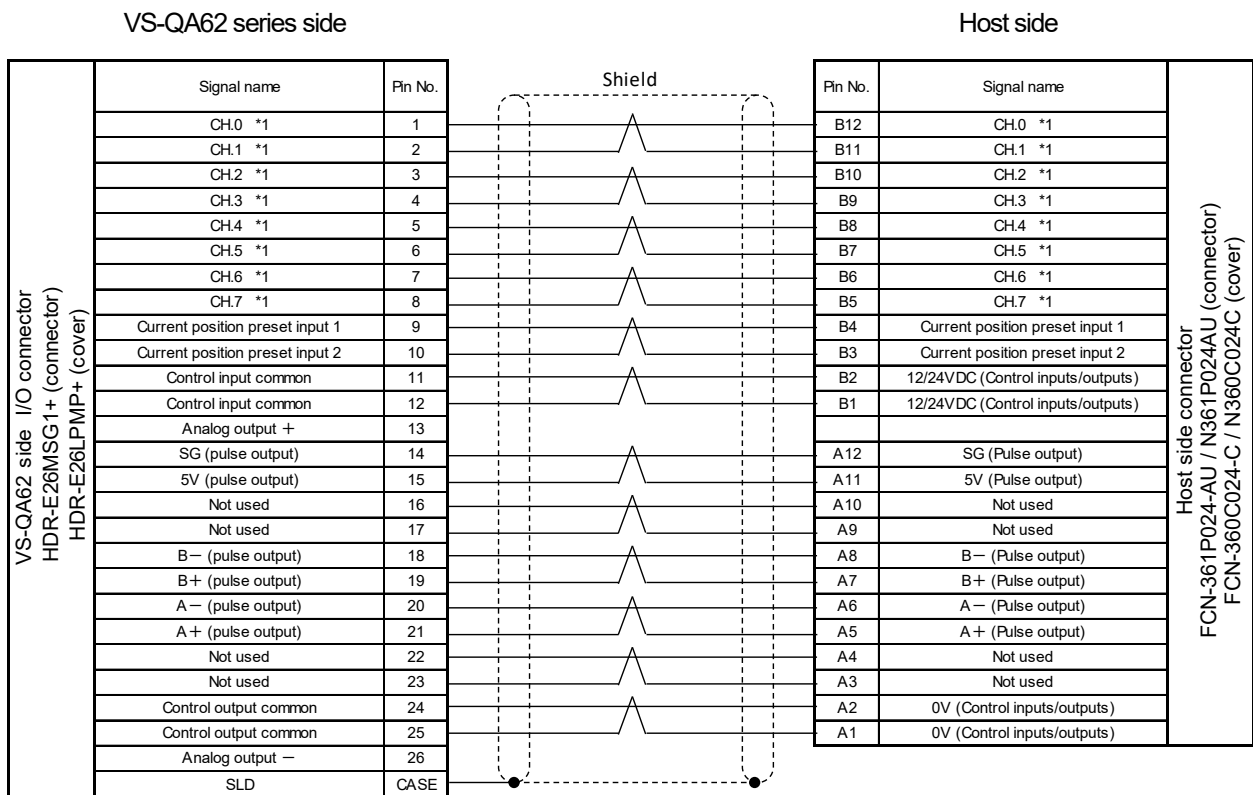
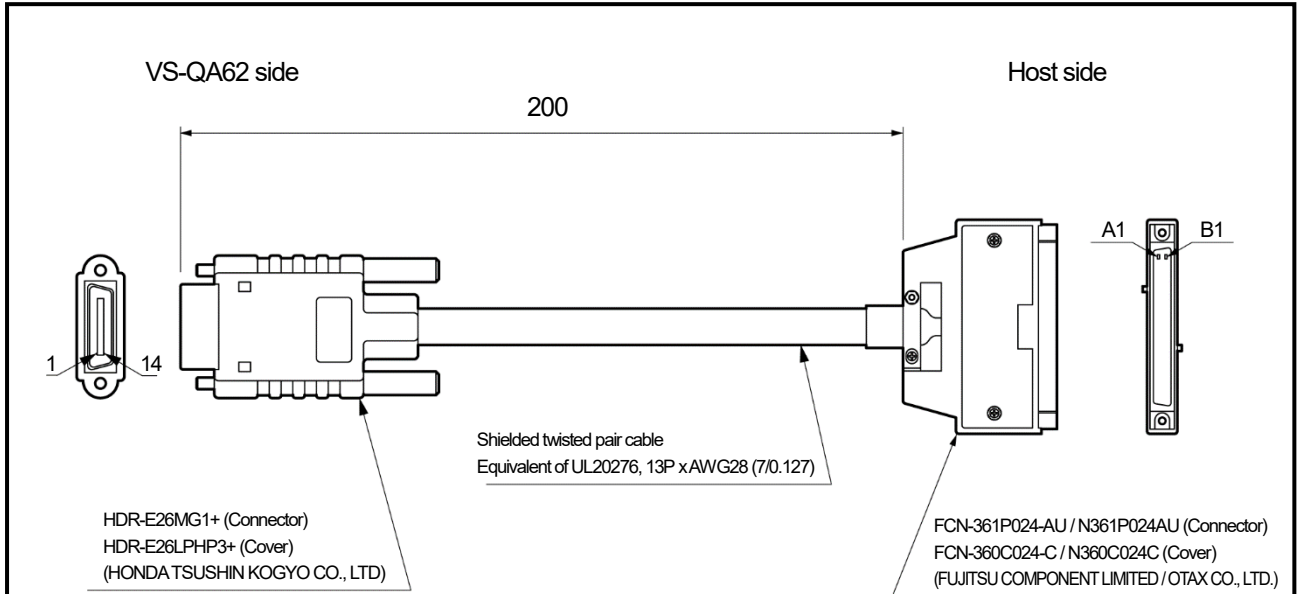

\*1: This figure indicates the signal name of the limit switch output function, but the signal changes to the positioning function according to the setting of the buffer memory address 711.  
For details of signal names, refer to 'Chapter 3.4.2'.



APPENDIX 2 ABSOCODER SENSOR SPECIFICATIONS

Appendix 2.1 Sensor Specifications

Items		Specifications					
Sensor model		MRE-32SP062	MRE-G[ ]SP062				
			[64]	[128]	[160]	[256]	[320]
Total number of turns		32	64	128	160	256	320
Divisions/Turn		4096	2048	1024	819.2	512	409.6
Total number of divisions		131072 (2 <sup>17</sup> )					
Mass		1.5 kg	1.0 kg				
Linearity error		1° Max	2 Max.	4 Max.	5 Max.	8 Max.	10 Max.
Moment of inertia GD <sup>2</sup> /4(J)		6.7 x 10 <sup>-6</sup> kg·m <sup>2</sup> (6.8 x 10 <sup>-5</sup> kgf·cm·s <sup>2</sup> )	3.9 x 10 <sup>-6</sup> kg·m <sup>2</sup> (4.0 x 10 <sup>-5</sup> kgf·cm·s <sup>2</sup> )				
Starting torque		4.9 x 10 <sup>-2</sup> N·m or less (0.5 kgf·cm or less)					
Permissible shaft load	Radial	98 N (10 kgf)					
	Thrust	49 N (5 kgf)					
Permissible mechanical speed		3600 r/min					
Bearing life		3.0 x 10 <sup>4</sup> h (at 3600 r/min)	1.5 x 10 <sup>4</sup> h (at 3600 r/min)				
Ambient temperature	Operating	-20 to +60°C					
	Storage	-30 to +90°C					
Vibration resistance		2.0 x 10 <sup>2</sup> m/s <sup>2</sup> (20G) 200Hz, up/down 4 h, forward/back 2 h, conforms to JIS D 1601 standard					
Shock resistance		4.9 x 10 <sup>3</sup> m/s <sup>2</sup> (500G) 0.5 ms, up/down/forward/back x 3 times each, conforms to JIS C 5026 standard					
Protection rating		IP52f, conforms to JEM 1030 standard					
Max. sensor cable length	Standard cable	100m					
	Robotic cable	40m	70m				
Interconnecting sensor cable length		2m					



Units: mm

■ MRE-32SP062FAC

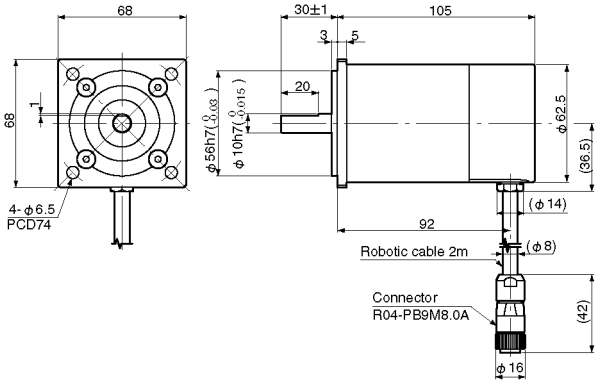

■ MRE-32SP062FBC

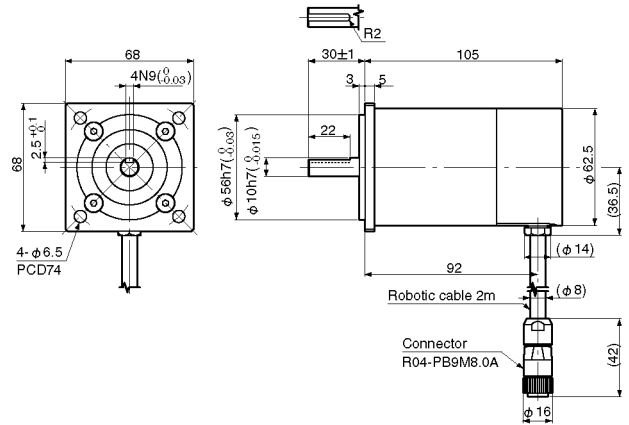

■ MRE-G[ ]SP062FAC ([ ]:64, 128, 160, 256, 320)

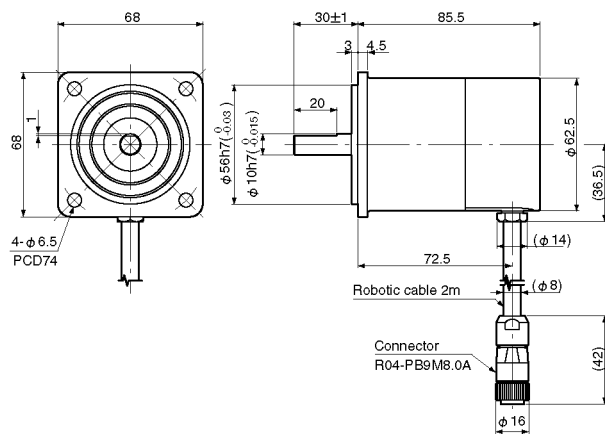

■ MRE-G[ ]SP062FBC ([ ]:64, 128, 160, 256, 320)

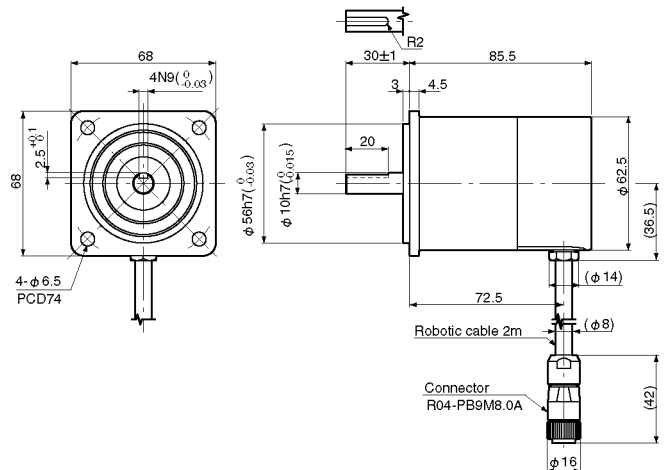

● Mounting hole dimensions for flange

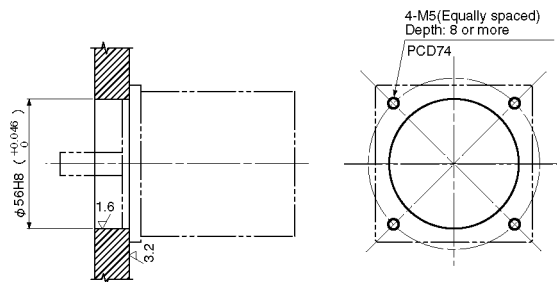

● Model: RB-01 (Option)

L-type flange for MRE-32SP062·MRE-G[ ]SP062

Applicable sensors are following.  
MRE-32SP062S[ ]C + SH-01  
MRE-32SP062F[ ]C  
MRE-G[ ]SP062F[ ]C

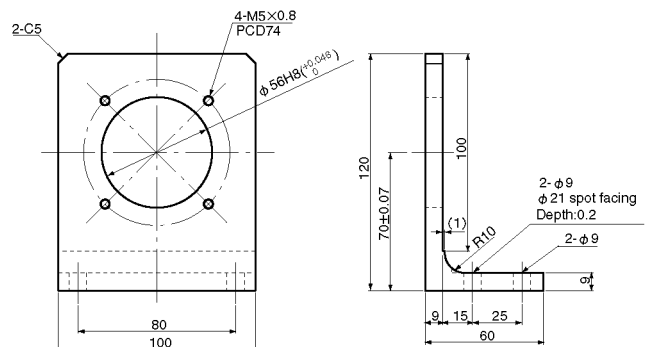

APPENDIX 3 ABSOCODER CABLE SPECIFICATIONS

Appendix 3.1 Cable Specifications

Items		Specifications	
Model code		4P-S	4P-RBT
Cable type		Standard cable	Robotic cable
Diameter		φ8	
Ambient temperature	Operating	-5 to +60°C	-5 to +60°C
	Storage	-5 to +60°C	-10 to +60°C
Insulator		Irradiated cross linked foamed polyethylene	ETFE plastic
Sheath		Polyvinyl chloride mixture	
Construction		8-core, 2 pairs without shield + 2 pairs with shield	
Color of sheath		Gray	Black
Advantage		Extensible for long distances	Superior flexibility; ideal for moving place

Appendix 3.2 Cable Length Restrictions

The permissible length of the extension cable varies according to the ABSOCODER sensor model, as shown in the following table.

Cable model	4P-S	4P-RBT
MRE- 32SP062	100m	40m
MRE-G[ ]SP062	100m	70m

**REMARKS**

Contact your NSD representative when the ABSOCODER cable combines different types of cables.  
The ABSOCODER cable is a dedicated product and is not interchangeable with any other type of cable.

Appendix 3.3 Cable Dimensions

Units: mm

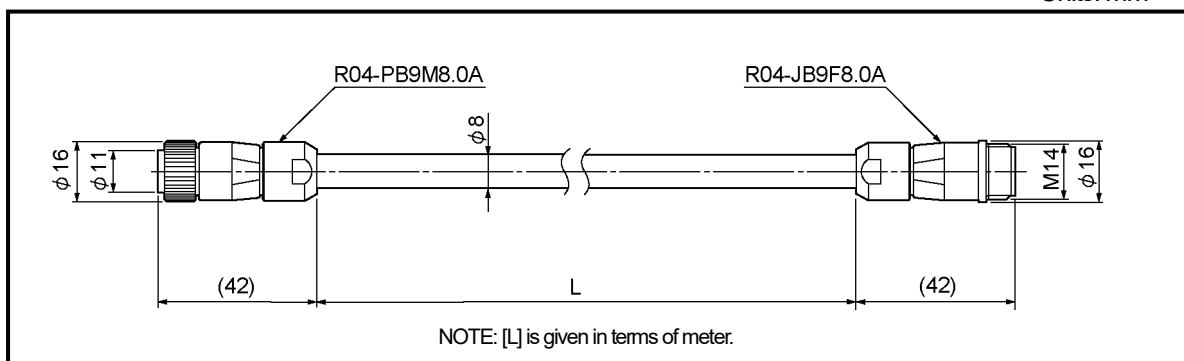

Appendix 3.4 Connection Example of the ABSOCODER Cable

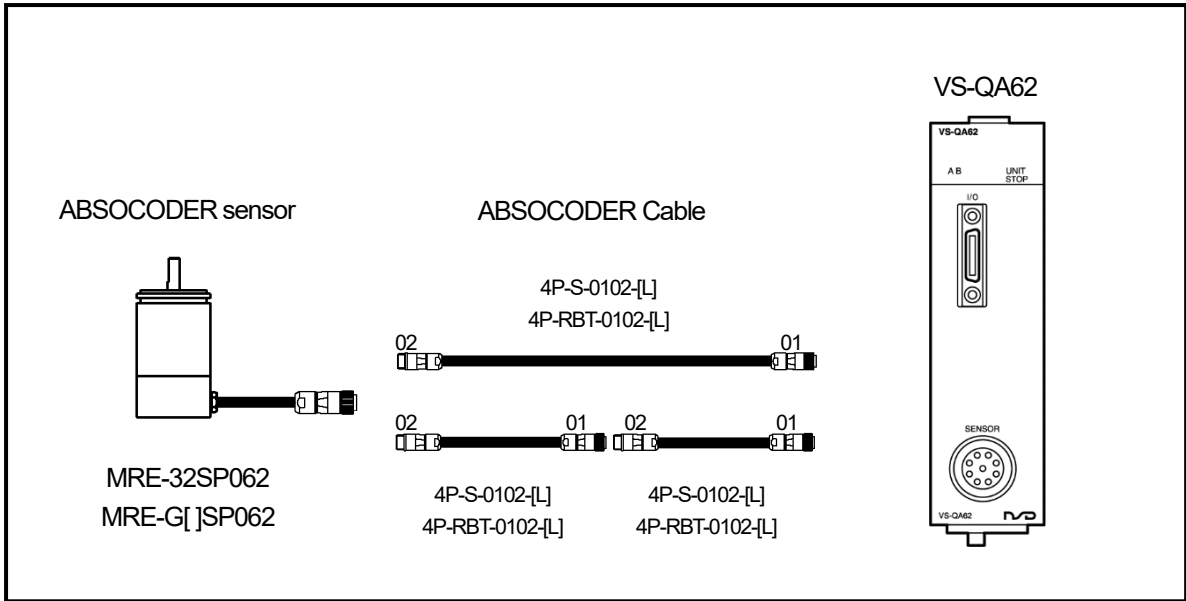



**APPENDIX 4 CE MARKING**

VS-QA62 series conforms to EMC directive, but stands outside scope of the low voltage directive.

**(1) EMC Directives**

It is necessary to do CE marking in the customer's responsibility in the state of a final product. Confirm EMC compliance of the machine and the entire device by customer because EMC changes configuration of the control panel, wiring, and layout.

**(2) EMC Directive and Standards**

EMC Directive consists of immunity and emission items.  
It conforms to Table 01(see below) of EMC standards and Testing.

Table 01 EMC Standard and Testing

Class	Standard No.	Name
EMC	EN61131-2	Equipment requirements and tests of programmable controllers
EMI (Emission)	EN55011 Class A	Electromagnetic Radiation Disturbance
EMS (Immunity)	EN61000-6-2	Generic standards. Immunity standard for industrial environments
	EN61000-4-2	Electrostatic Discharge
	EN61000-4-3	Radiated, Radio frequency, Electromagnetic Field
	EN61000-4-4	Electrical Fast Transient / Burst
	EN61000-4-5	Surge Immunity
	EN61000-4-6	Conducted Disturbances, Induced by Radio-Frequency Fields
	EN61000-4-8	Power Frequency Magnetic Field

**(4) Restrictions for EMC Compliance**

- PLC must be installed in the control panel.  
Refer to the CPU user's manual (Hardware Design / Maintenance and Inspection) for details of the install method.
- The length of I/O cable must be under 30m.
- Install the zippertubing around the cable when sensor cable is used 30m or more. The shield of zippertubing should grounded.

Recommendation zippertubing

Mounting location	Model	Manufacturer
Sensor cable	MTFS 20φ	ZIPPERTUBING(JAPAN), LTD.

**[Reference]**

It may be improved when clamp ferrite core is added to the extension sensor cable and I/O cable when it operates faultily by the influence from the peripheral device.

Recommendation Clamp Ferrite Core

Mounting location	Clamp ferrite core model	Manufacturer
- Extension sensor cable - I/O cable	ZCAT2032-0930 (Inner dimensions: φ9)	TDK

## APPENDIX 5 UL STANDARD

The VS-QA62 Series corresponds to the UL standard.

Read this page carefully and use the VS-QA62 Series by following the described items.

### (1) Installation

- Install inside the control cabinet.
- For use in pollution degree 2 environment.
- Within the surrounding air temperature 0°C to 55°C.
- Built in to Q-series PLC by Mitsubishi Electric Co.

### (2) Compliance power supply

- VS-QA62 shall not conform to UL and cUL standards, unless a power supply to a PLC base is made by Mitsubishi Electric Co., that is insulated and whose secondary is LVLC (Limited voltage/current circuit) defined in UL508.
- Use only a Class 2 power supply to external input/output signal lines.

### (3) Wiring for external I/O

- Use field installed conductors with a temperature rating of 75°C or higher.

#### **CAUTION**

DO NOT CONNECT DIRECTLY TO LINE VOLTAGE. LINE VOLTAGE MUST BE SUPPLIED BY A SUITABLE, APPROVED ISOLATING POWER SUPPLY HAVING SHORT CIRCUIT CAPACITY NOT EXCEEDING 100 VA MAXIMUM

## APPENDIX 6 KC MARK

## Notification for users

## 사용자안내문

This product complied with the relevant Korean Safety Standard for use in the industrial environment.  
Thus, radio frequency interference could occur if it is used in a domestic environment.

이 기기는 업무용 환경에서 사용할 목적으로 적합성평가를 받은 기기로서  
가정용 환경에서 사용하는 경우 전파간섭의 우려가 있습니다.

APPENDIX 7 ABSOCODER SENSOR CHECK LIST

● Applicable ABSOCODER sensor models

MRE-32SP062

MRE-G[ ]SP062 [ ]: 64, 128, 160, 256, 320

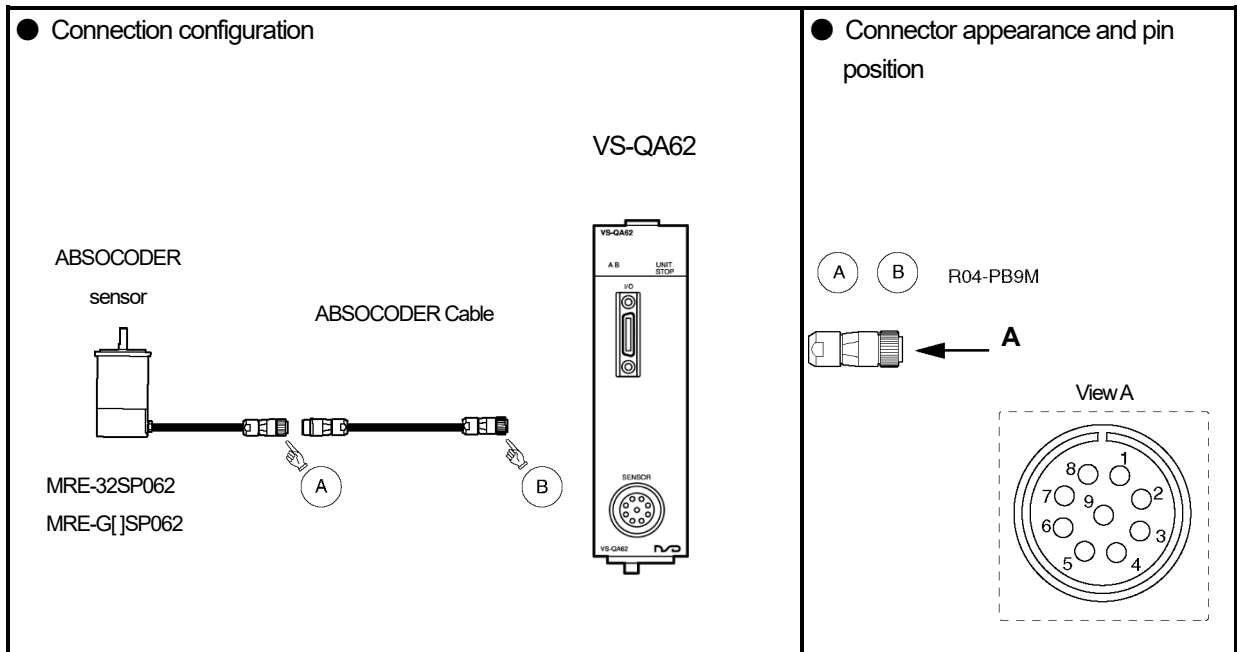

Checks at Point B should be carried out with Point A connected.

● Connector pin position and standard coil resistance ranges (at 25°C)

Connector pin No.	Signal name	Wiring color	Standard coil resistance [ $\Omega$ ]	
			MRE-32SP062	MRE-G[ ]SP062
1	SIN+	Brown	100 to 120	115 to 123
2	SIN-	Red		
3	-COS+	Orange	100 to 120	115 to 123
4	-COS-	Yellow		
5	OUT1+	Green	4 to 10	28.5 to 40.5
6	OUT1-	Blue		
7	OUT2+	Violet	113 to 137	28.5 to 40.5
8	OUT2-	Gray		
9	Shield	Shield	—	—
—	—	—	—	—

The above standard coil resistance ranges are referential data to assist wiring disconnection diagnosis and are not product specification values. There may be no wiring disconnection even when the resistance measurement is out of the standard resistance range.

● **Circuit resistance check**

[Measurement method]

Measure resistance at Point A or B using a circuit tester or other appropriate device.

If the connector is off, identify the line by the wiring color.

[Check details]

Refer to the previous page for the connector pin number.

Check position	Criterion	Check position	Criterion
Between brown and red	The measured value should be in the range of the standard coil resistance. *1	Between brown and orange, green, violet, shield	∞
Between orange and yellow		Between orange and green, violet, shield	
Between green and blue		Between green and violet, shield	
Between violet and gray		Between violet and shield	
		Between frame and each wire	

\*1: If checks are done at Point B, the measurement value is [Standard coil resistance + ABSOCODER cable resistance (cable length (m) x 0.2 (Ω))].

The resistance value of the ABSOCODER cable is 0.2Ω/m (loop resistance).

Consider resistance variations due to temperature, which, relative to the standard temperature (25°C), increases 0.4% when the temperature rises 1°C and decreases 0.4% when the temperature falls 1°C.

● **Insulation check**

[Measurement method]

Measure using a 500 VDC insulation tester.

[Check details]

Refer to the previous page for the connector pin number.

Check position	Criterion
Between brown and orange, green, violet, shield	10MΩ or more
Between orange and green, violet, shield	
Between green and violet, shield	
Between violet and shield	
Between frame and each wire	

**IMPORTANT**

1. Make sure to disconnect the ABSOCODER sensor from VS-QA62 before carrying out insulation checks.
2. If there is a risk that energization may cause damages to the electronic circuits in and around the machine, remove the ABSOCODER sensor from the machine.
3. After completing the checks, short-circuit between the pins to discharge remaining voltage before connecting the ABSOCODER sensor to VS-QA62.

APPENDIX 8 SAMPLE PROGRAM

This chapter explains how to create the sample program using VS-QA62.

Appendix 8.1 Program Creation Precautions

- (1) VS-QA62 is an intelligent function module that occupies 32 I/O points.
- (2) In response to 'FROM/TO' instructions, the first input/output No. of VS-QA62's slot will be designated.

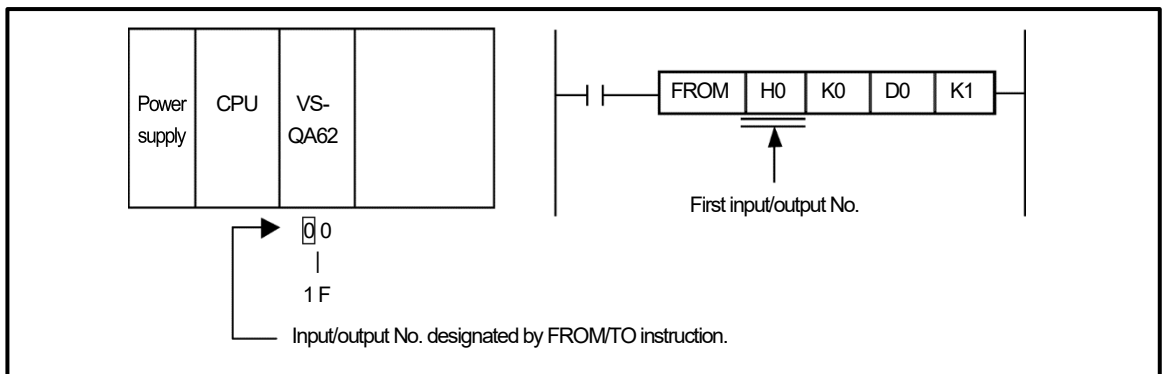

- (3) The following designation enables to execute instructions to VS-QA62 as an intelligent function device.

Designation method: U□≠G□

- Buffer memory address
- VS-QA62's first input/output No.

Setting: When the VS-QA62 first input/output No. is expressed as a 3-digit No., the upper 2 digits are specified.

When the VS-QA62 first input/output No. starts with 0E0, "0E" is specified. (U0E≠G0).

- (4) VS-QA62 control starts when the Y10 signal (PLC ready signal) is turned ON.
- (5) To stop all VS-QA62 control, turn Y10 (PLC ready signal) OFF.
- (6) Error reset:  
Correct the error cause, and turn Y16 ON (leading edge).  
It might take 12ms for VS-QA62 to detect the Y16 signal (error reset) after it has been turned ON.

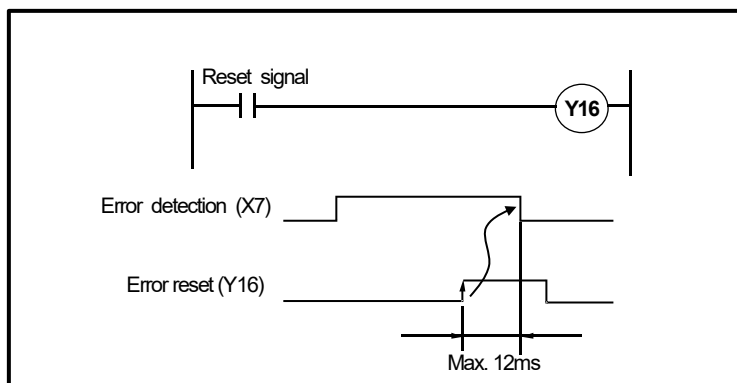

**Appendix 8.2 Program for Writing Initial Settings and Parameter Settings**

A program example for writing the initial setting and the parameter data to the VS-QA62 buffer memory is given below.

**Example 1**

The setting data saved at the programmable controller CPU's data register is written to the initial setting area, and the current position value is set.

**Conditions**

- (1) The following signal assignments are used to control VS-QA62.  
 VS-QA62 online command ..... X20  
 Initial setting write command ..... X21  
 Data memory flag answerback storage register ..... D0
- (2) The initial setting data should be stored in the data register in advance.

Data register		Buffer memory	
D10002		702	Sensor rotation direction
D10003		703	Not used
D10004		704	(L) Scale length
D10005		705	(H) Scale length
D10006		706	(L) Minimum current position value
D10007		707	(H) Minimum current position value
D10008		708	(L) Current position value
D10009		709	(H) Current position value
D10010		710	Current position change command

Write "1" to D10010 in order to perform a current position setting.

- (3) Move the machine to the reference position before writing data with this sequence program.

**Program Example**

(1) Examples of programs using the FROM/TO instructions

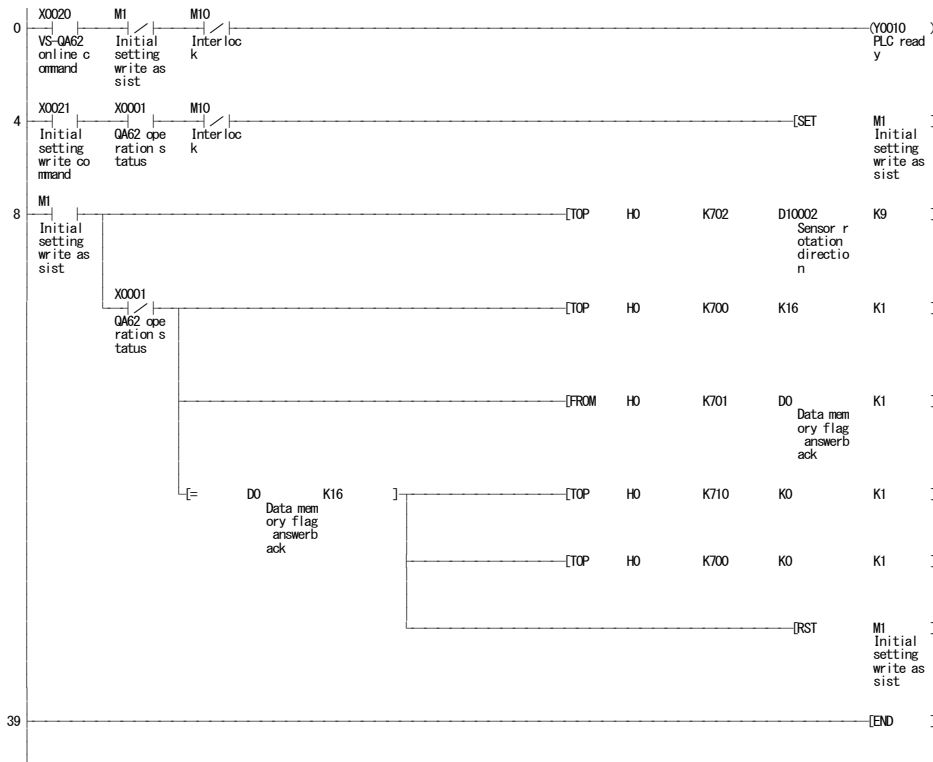

The PLC ready signal of VS-QA62 is turned ON.

Initial setting write command

Initial setting writing to buffer memory

The initial setting writing bit is written to the buffer memory's data memory flag.

The buffer memory's data memory flag answerback is read.

The data memory flag and the current position change command clear when initial setting writing is completed.

(2) Example of a program using an intelligent function device (U[ ]G[ ])

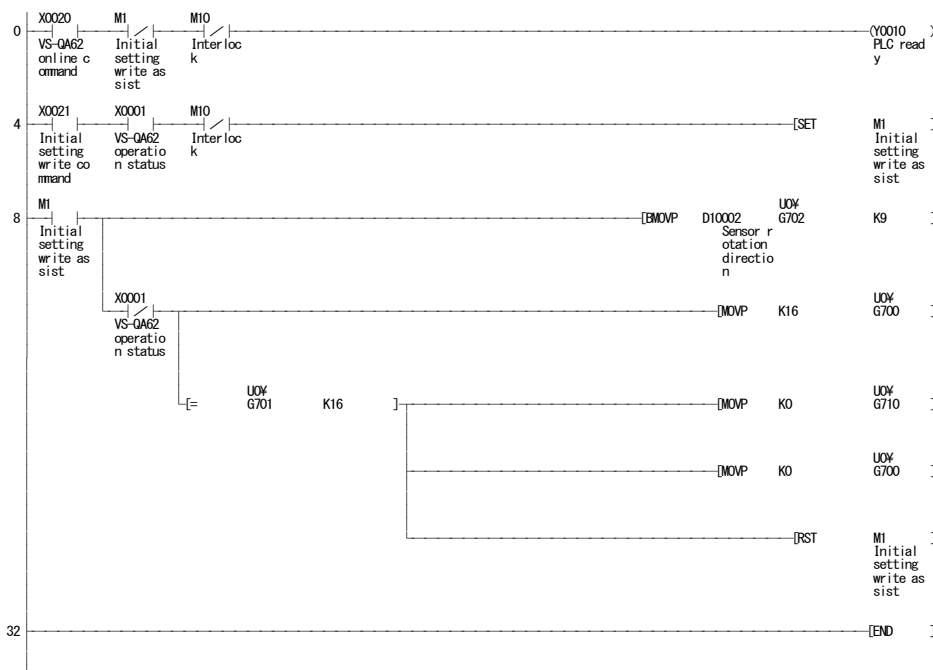

The PLC ready signal of VS-QA62 is turned ON.

Initial setting write command

Initial setting writing to buffer memory

The initial setting writing bit is written to the buffer memory's data memory flag.

The buffer memory's data memory flag answerback is read.

The data memory flag and the current position change command clear when initial setting writing is completed.

**IMPORTANT**

Check whether an error code is stored in Address 7 of the buffer memory if a value which is set to Address 700 doesn't return to the 'data memory flag answerback' (Address 701). For the error checking program, refer to 'Appendix 8.4'.



**Example 2**

The setting data saved at the programmable controller CPU's data register is written to the parameter area.

**Conditions**

- (1) The following signal assignments are used to control VS-QA62.
  - VS-QA62 online command ..... X20
  - Parameter setting write command ..... X21
  - Data memory flag answerback storage register ..... D0

- (2) The parameter setting data should be stored in the data register in advance.

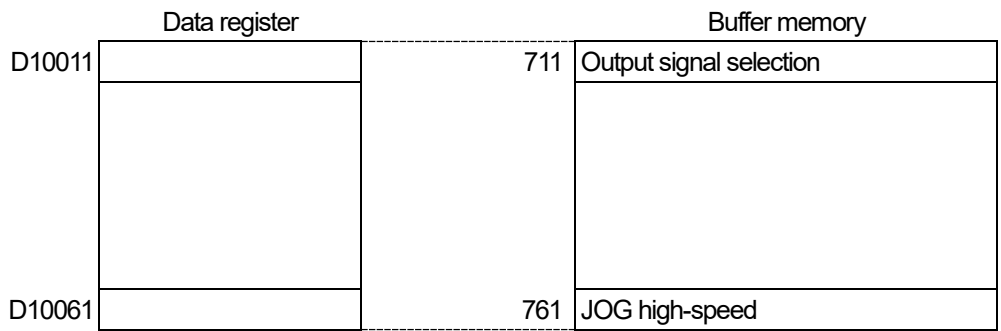

**Program Example**

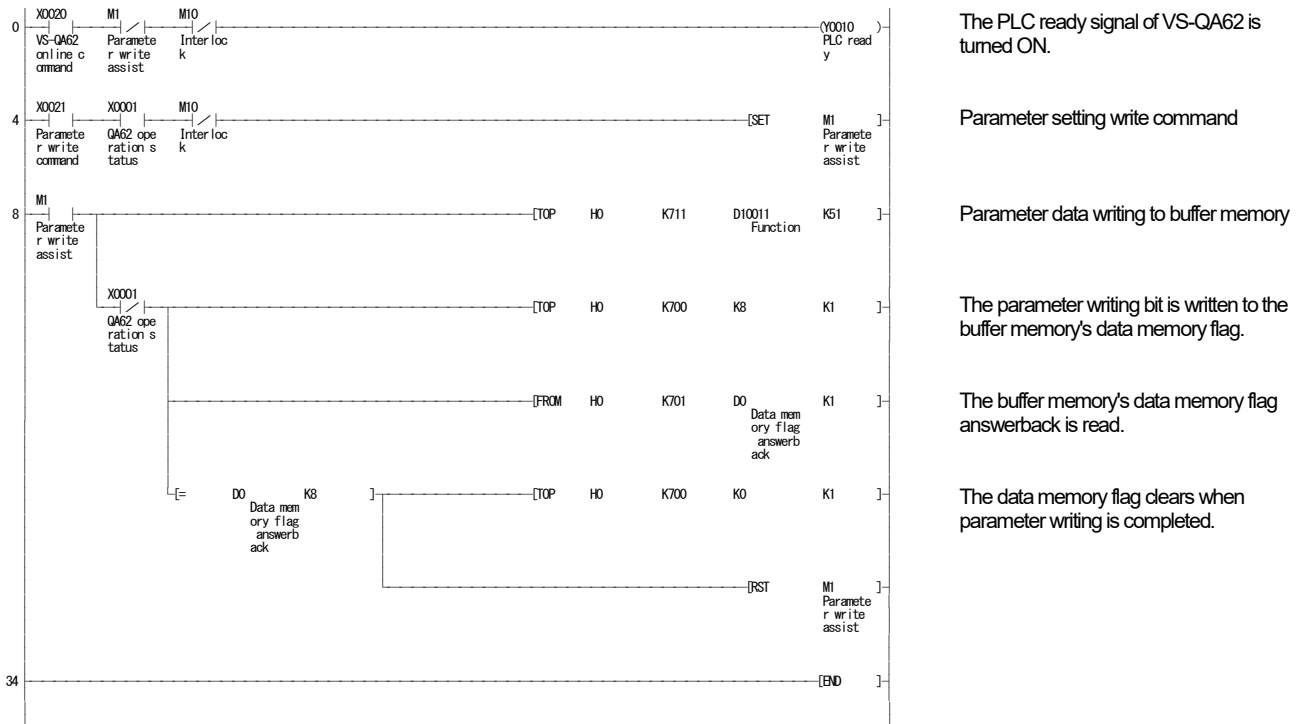

**IMPORTANT**

Check whether an error code is stored in Address 7 of the buffer memory if a value which is set to Address 700 doesn't return to the 'data memory flag answerback' (Address 701). For the error checking program, refer to 'Appendix 8.4'.

**Example 3**

The setting data saved at the programmable controller CPU's data register is written to the initial setting and parameter areas, and the current position value is set.

**Conditions**

(1) The following signal assignments are used to control VS-QA62.

VS-QA62 online command ..... X20

Initial setting write command ..... X21

Data memory flag answerback storage register ..... D0

(2) The initial setting data and parameter setting data should be stored in the data register in advance.

Data register		Buffer memory	
D10002		702	Sensor rotation direction
D10003		703	Not used
D10004		704	(L) .....
D10005		705	(H) ..... Scale length
D10006		706	(L) .....
D10007		707	(H) ..... Minimum current position value
D10008		708	(L) .....
D10009		709	(H) ..... Current position value
D10010		710	Current position change command
D10011		711	Output signal selection
D10061		761	JOG high-speed

Write "1" to D10010 in order to perform a current position setting.

(3) Move the machine to the reference position before writing data with this sequence program.

**Program Example**

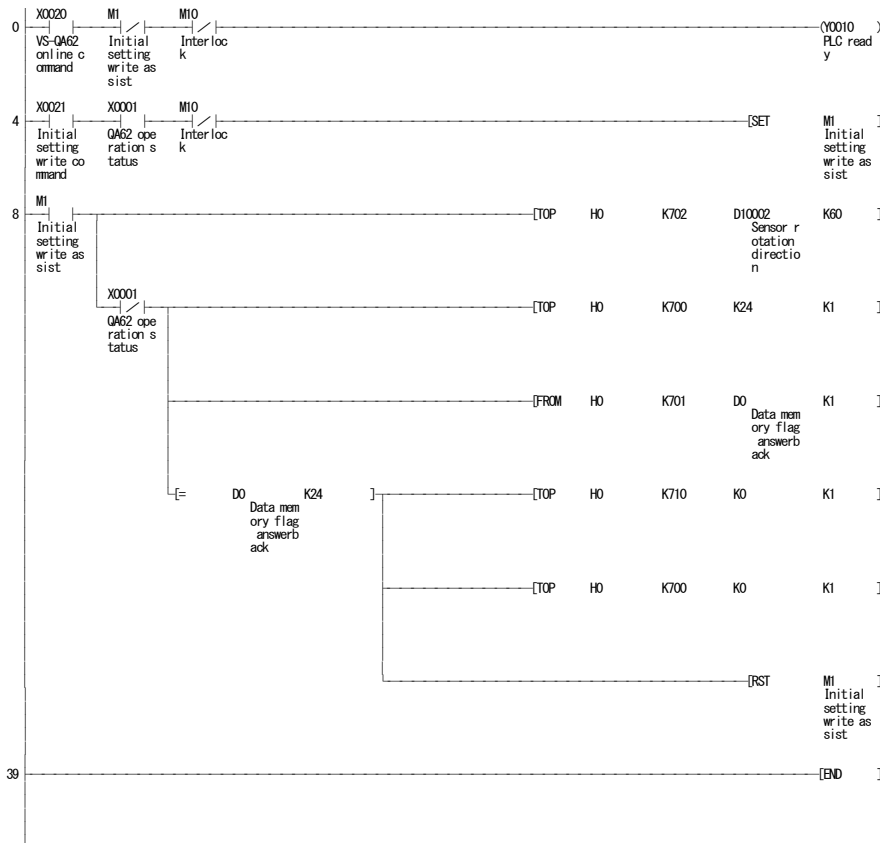

The PLC ready signal of VS-QA62 is turned ON.

Initial setting write command

Initial setting and parameter data are written to the buffer memory.

The initial setting writing bit and the parameter writing bit information is written to the buffer memory's data memory flag.

The buffer memory's data memory flag answerback is read.

The data memory flag and the current position change command clear when initial setting and parameter writing is completed.

**IMPORTANT**

Check whether an error code is stored in Address 7 of the buffer memory if a value which is set to Address 700 doesn't return to the 'data memory flag answerback' (Address 701). For the error checking program, refer to 'Appendix 8.4'.

Appendix 8.3 Program for Current Position Monitor Display

A program example for the current position monitor display is given below.

Conditions

The following signal assignments are used to control VS-QA62.

- VS-QA62 online command ..... X20
- Current position value (scaling binary) storage register ..... D10, D11, D12, D13
- Current position value (scaling binary) output to external display units ..... Y40 to Y57
- External output signal for minus sign ..... Y58

Program Example

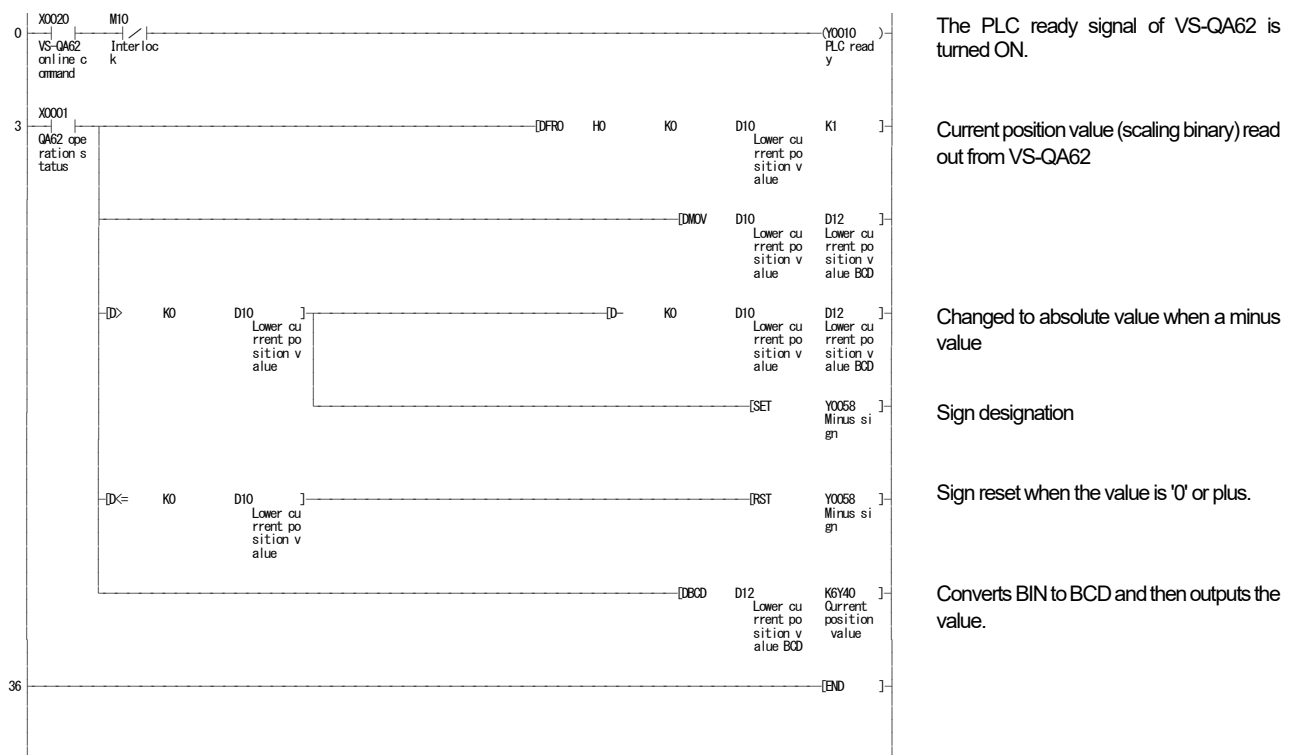

Explanation

- (1) When VS-QA62 is online, the 'X1' signal turns ON.
- (2) The current position value (scaling binary) is readout from the buffer memory as follows:

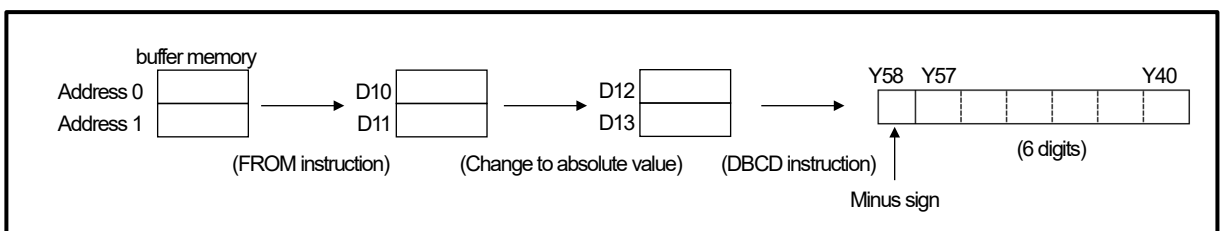

Appendix 8.4 Program for Error Code Readout and Reset

This chapter explains a program example for the error code readout and error reset operation from VS-QA62.

Conditions

The following signal assignments are used to control VS-QA62.

Output for error code display ..... Y60~Y6F

Output for 'error detection' monitor ..... Y5F

Error reset signal ..... X80

Program Example

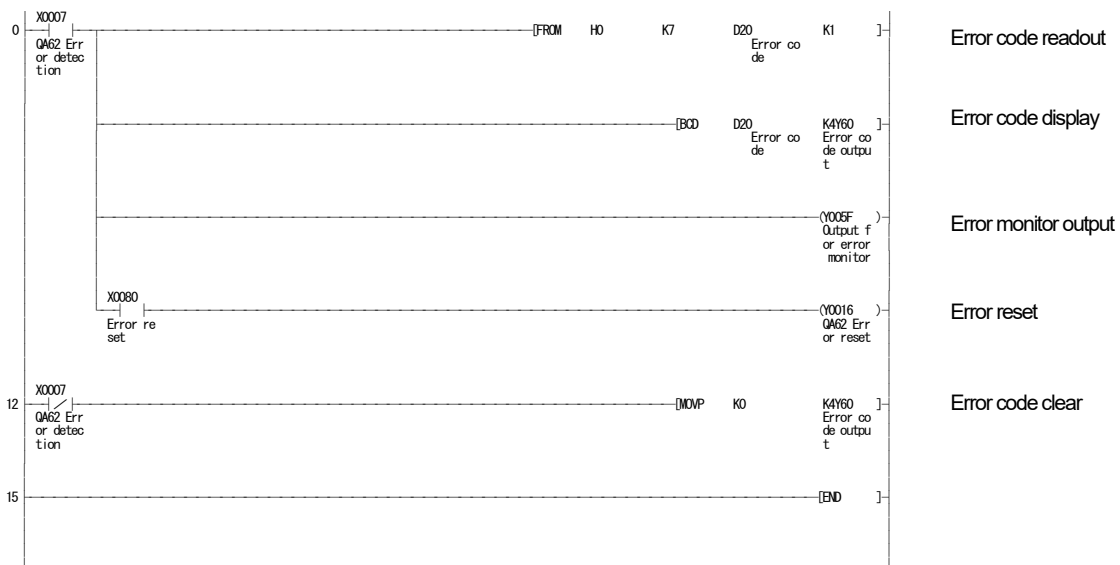

**Appendix 8.5 Program for Limit Switch Output Function**

To start the limit switch output function by designating the desired setting data which is stored at the PLC CPU's data register, and writing that data to the limit switch area.

**Conditions**

- (1) The following signal assignments are used to control VS-QA62.
- VS-QA62 online command ..... X20
  - Program No. 'write' command ..... X23
  - Program selection switch ..... X3D (For program A)
  - ..... X3E (For program B)
  - ..... X3F (For program C)
  - Limit switch output function START command ..... X24
  - Limit switch output prohibit channel information register ..... D30
  - Selected program No. register ..... D33
  - 'Program switching answer' storage register ..... D34
  - Limit switch output CH. 0 to CH.15 ..... M20 to M35
- (2) The setting data for programs A to C has already been saved at the data register.

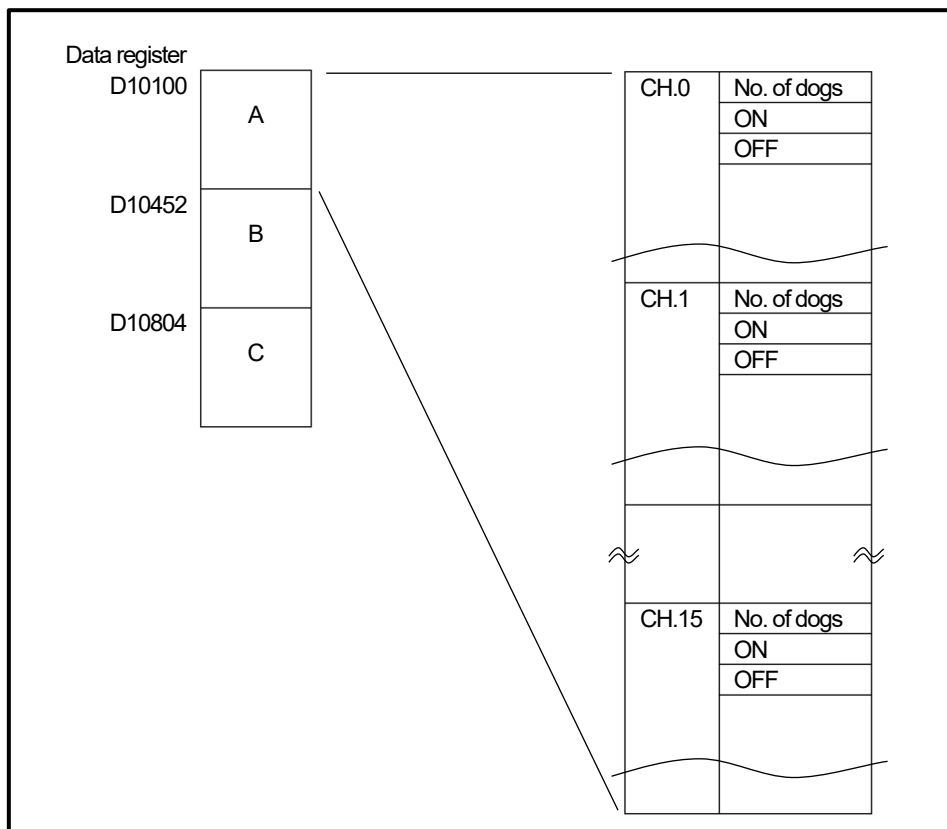

- (3) The number of channels varies according to the program used:
- Program A: Channels 0 to 11
  - Program B: Channels 0 to 7, 12 to 15
  - Program C: Channels 0 to 3, 8 to 15

**Program Example**

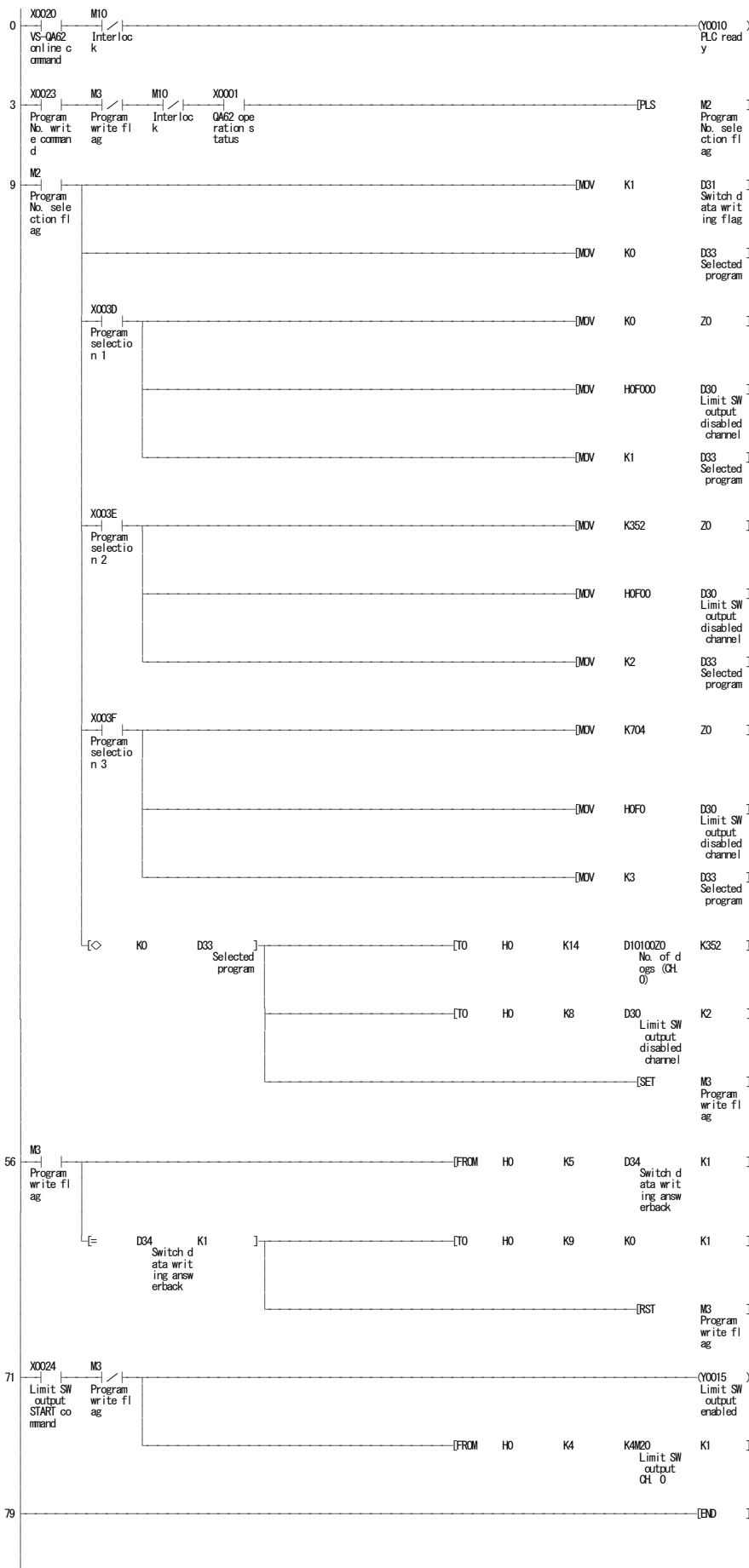

The PLC ready signal of VS-QA62 is turned ON.

Program No. 'write' command

Program No. write command, switch data writing flag data set

Selected program data initialized

Program selection  
'Output disabled' channels will vary according to the program which is selected.

★Program is stored in the data register.

Limit switch data is written to VS-QA62.

The "limit switch prohibit channel" and the limit switch writing command are written to VS-QA62.

The limit switch writing command answerback is verified.

Limit switch function starts

The output statuses of all buffer memory channels are developed at M20 to M35.

Appendix 8.6 Readout Program of the Limit Switch Output Status

A program example for the ON/OFF status readout of each of the 16 channels (0-15) is given below.

Conditions

- The following signal assignments are used to control VS-QA62.
- Output status storage register..... D30
- Output status detection for each channel..... M0 to M15
- Output status readout command..... X30

Program Example

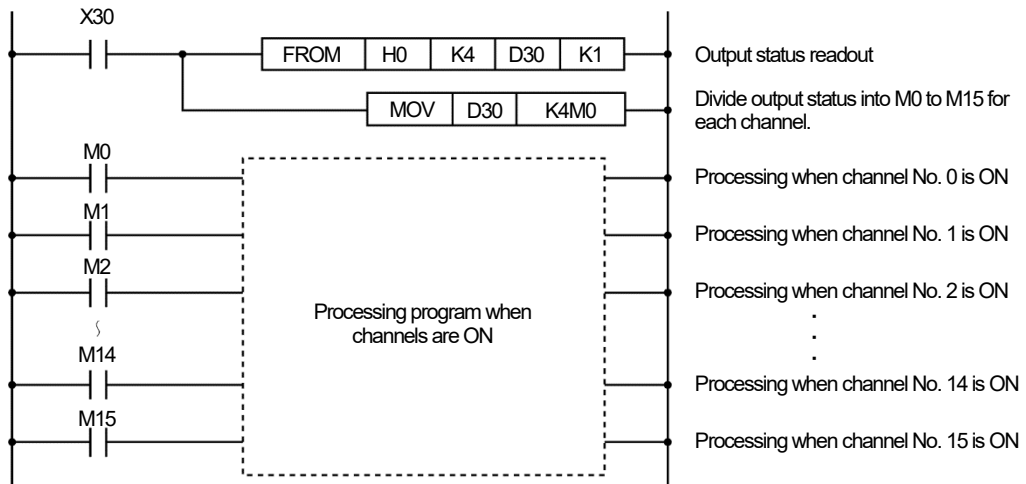

Explanation

(1) The output status is stored at address 4 of the buffer memory as follows:

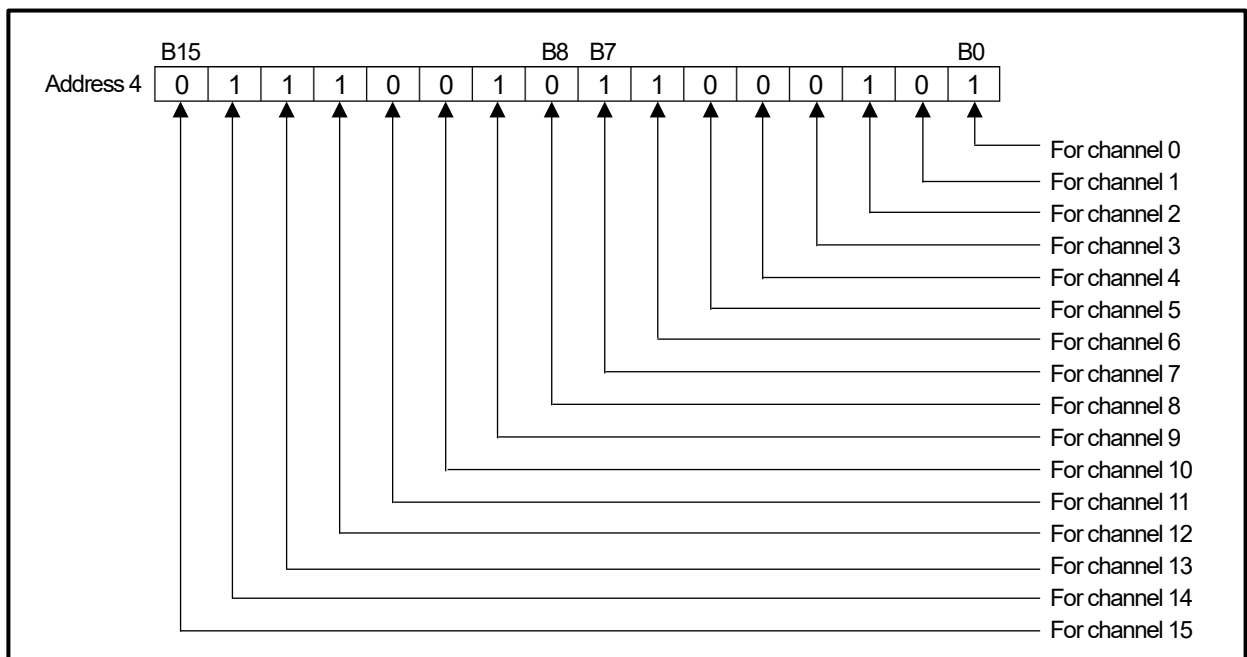



Appendix 8.7 Program for Positioning Function

The following example shows a program used to designate the target value and to start the positioning function.

**Conditions**

- (1) The following signal assignments are used to control VS-QA62.
- |  |       |   |
|--|-------|---|
| VS-QA62 online command                       | ..... | X20   |
| 'Target value change' command                | ..... | X25   |
| Positioning START command                    | ..... | X26   |
| Positioning STOP command                     | ..... | X27   |
| Target value setting input commands          | ..... | X28 to X3B (Digital SW, BCD 5-digit)                              |
|  | ..... | X3C (Digital SW, minus sign)                                      |
| Target value error display                   | ..... | Y7F (This example applies when outside a range of 2000 to 34000.) |
| 'Stopped outside target range' error display | ..... | Y7E   |
| Target value storage register                | ..... | D50, 51   |

(2) The program creation and the operation procedure are as follows:

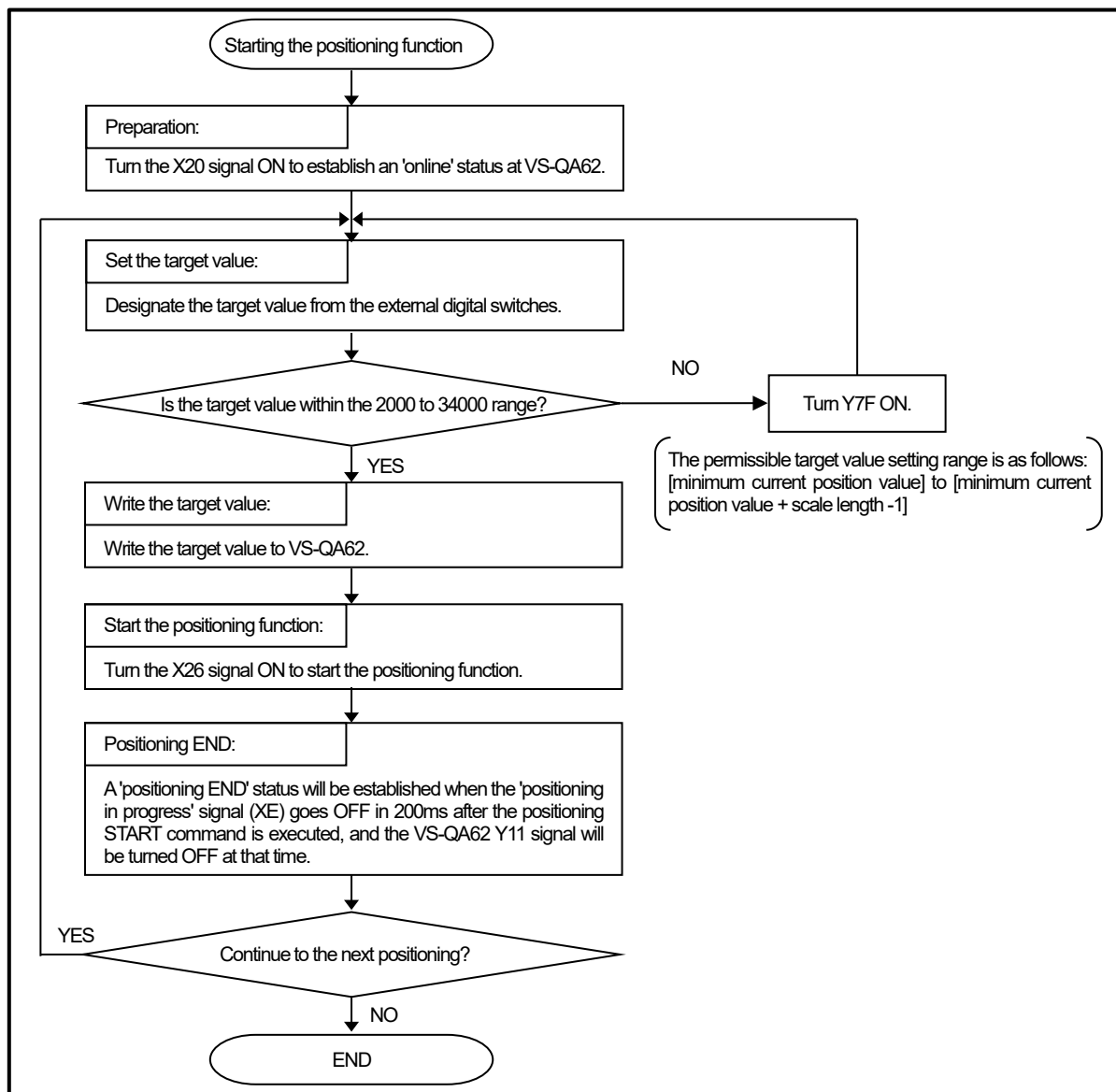

Program Example

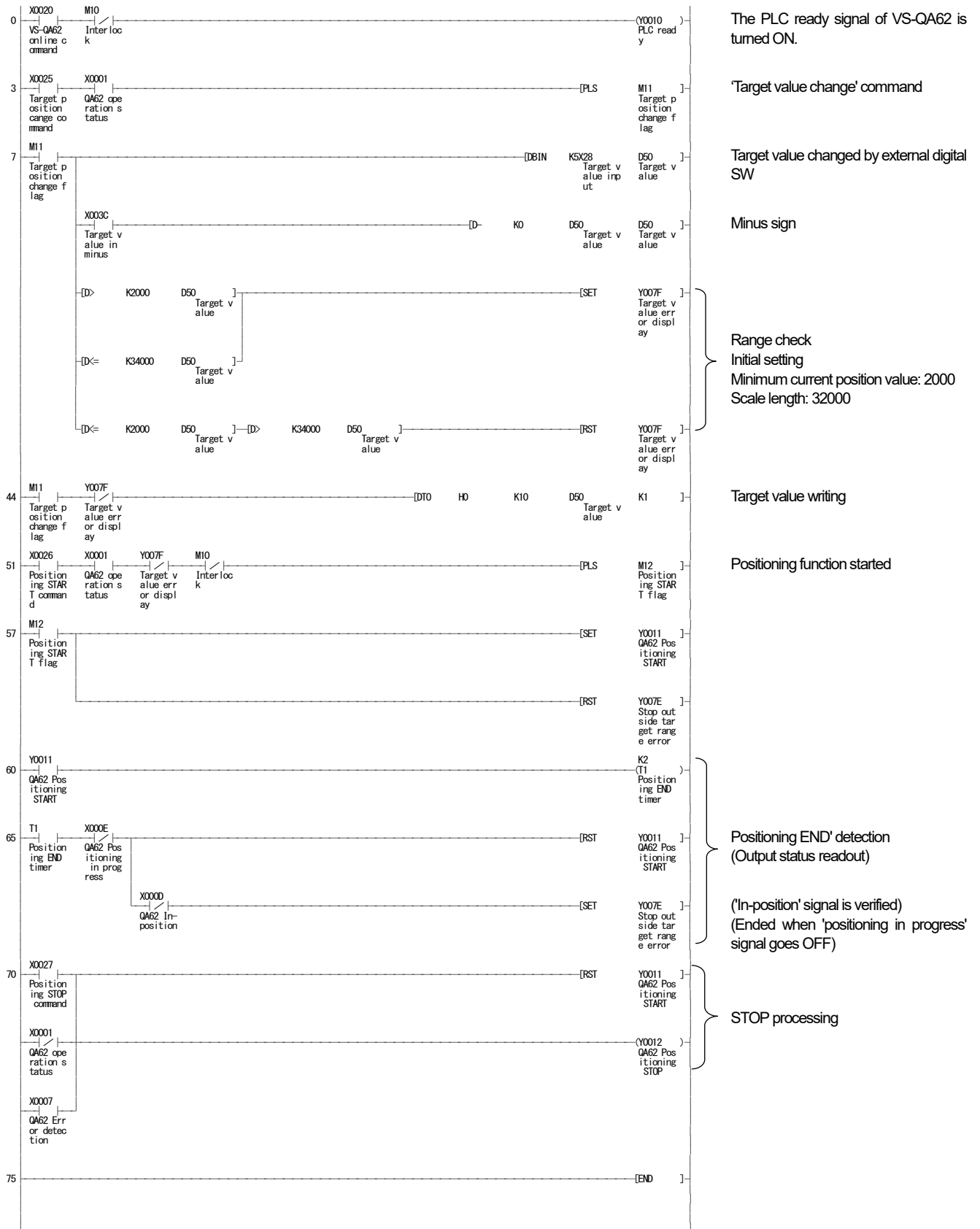

Explanation
-------------

- (1) The positioning function starts when the Y10 and Y11 signals turn ON.
- (2) X1 is the ON signal when the VS-QA62 online status has been established (Y10 ON).
- (3) The output status can be checked X8 to XF of VS-QA62.
  - X8 ..... FWD / Low-speed
  - X9 ..... RVS / Low-speed
  - XA ..... High-speed
  - XB ..... Low-speed / Medium-speed
  - XC ..... Brake release
  - XD ..... In-position
  - XE ..... Positioning in progress
  - XF ..... Operation error
- (4) The target value must be designated within the following range:  
[Minimum current position value] to [minimum current position value + scale length -1].  
A range check is executed by the sequence program.
- (5) A 'positioning END' status is established when the 'positioning in progress' signal (XE) goes OFF in 200ms after the positioning START signal is turned ON.

Appendix 8.8 Program for JOG operation

This chapter explains how to create the sequence program for the JOG operation.

**Conditions**

The following signal assignments are used to control VS-QA62.

- VS-QA62 online command ..... X20
- 'JOG mode selection' command ..... X81
- FWD JOG command ..... X82
- RVS JOG command ..... X83

**Program Example**

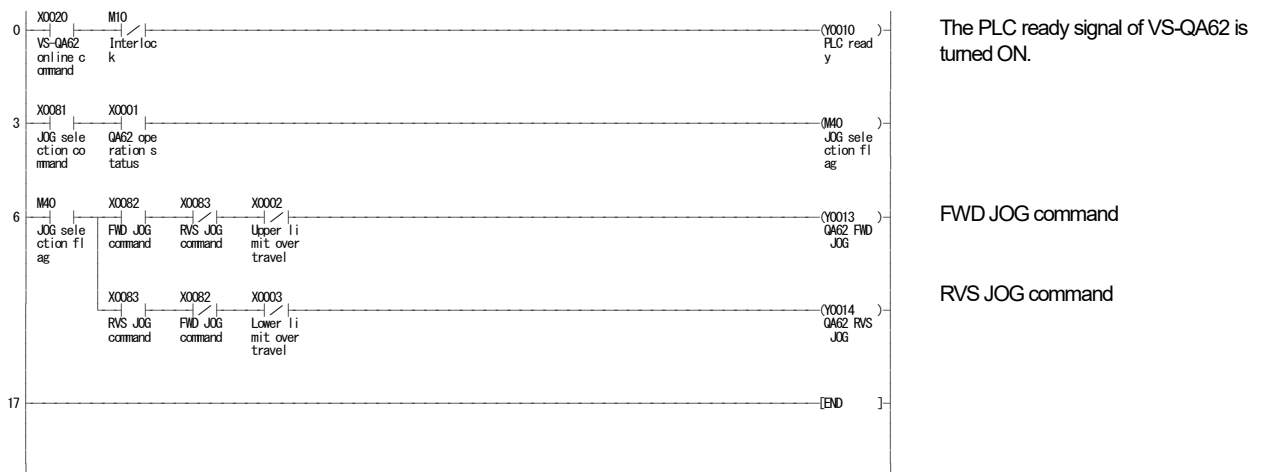

**Explanation**

- (1) X1 is the ON signal when the VS-QA62 online status has been established (Y10 ON).
- (2) X2 is the 'upper limit overtravel' detection signal.
- (3) X3 is the 'lower limit overtravel' detection signal.
- (4) JOG operation starts when the Y10 and Y13 (or Y14) signals turn ON.

**IMPORTANT**

If the motor wiring is incorrect, the RVS signal may be turned ON when the FWD signal is designated. Be sure the wiring is correct.

For the JOG operation, the following interlock conditions are required at the sequence program:

- (1) Simultaneous FWD and RVS operation.
- (2) FWD and upper limit overtravel (X2).
- (3) RVS and lower limit overtravel (X3).

APPENDIX 9 I/O SIGNALS AND BUFFER MEMORY FUNCTION LIST

○ : Function enabled    × : Function disabled    1/4

Signal type	VS-QA62 (online/offline)				Remarks																																																
	Device No. and name	Online	Offline																																																		
Signal inputs to PLC CPU	X0	Unit ready (VS-QA62 detection item)	○	○																																																	
	X1	VS-QA62 operation status (online/offline)	ON	OFF	This signal turns ON(online) when Y10 is turned ON																																																
	X2	'Upper limit overtravel' detection	○	×																																																	
	X3	'Lower limit overtravel' detection	○	×																																																	
	X4	Sensor error detection	○	○																																																	
	X5	'Excessive correction amount' detection	○	×																																																	
	X6	'Excessive current position change' detection	○	○																																																	
	X7	Error detection	○	○																																																	
	X8 to XF	A content varies according to the 'output signal selection'.				Equivalent to external output																																															
			<table border="1"> <thead> <tr> <th rowspan="2"></th> <th rowspan="2">For limit switch output</th> <th colspan="3">For positioning</th> </tr> <tr> <th>Speed switching format</th> <th>Speed stepping format</th> <th>Acceleration/Deceleration control format</th> </tr> </thead> <tbody> <tr> <td>X8</td> <td>Channel 0</td> <td>FWD</td> <td>FWD/Low-speed</td> <td>FWD</td> </tr> <tr> <td>X9</td> <td>Channel 1</td> <td>RVS</td> <td>RVS/Low-speed</td> <td>RVS</td> </tr> <tr> <td>XA</td> <td>Channel 2</td> <td>High-speed</td> <td>High-speed</td> <td>Not used</td> </tr> <tr> <td>XB</td> <td>Channel 3</td> <td>Low-speed</td> <td>Medium-speed</td> <td>Not used</td> </tr> <tr> <td>XC</td> <td>Channel 4</td> <td>Brake release</td> <td>Brake release</td> <td>Brake release</td> </tr> <tr> <td>XD</td> <td>Channel 5</td> <td>In-position</td> <td>In-position</td> <td>In-position</td> </tr> <tr> <td>XE</td> <td>Channel 6</td> <td>Positioning in progress</td> <td>Positioning in progress</td> <td>Positioning in progress</td> </tr> <tr> <td>XF</td> <td>Channel 7</td> <td>Operation error</td> <td>Operation error</td> <td>Operation error</td> </tr> </tbody> </table>					For limit switch output	For positioning			Speed switching format	Speed stepping format	Acceleration/Deceleration control format	X8	Channel 0	FWD	FWD/Low-speed	FWD	X9	Channel 1	RVS	RVS/Low-speed	RVS	XA	Channel 2	High-speed	High-speed	Not used	XB	Channel 3	Low-speed	Medium-speed	Not used	XC	Channel 4	Brake release	Brake release	Brake release	XD	Channel 5	In-position	In-position	In-position	XE	Channel 6	Positioning in progress	Positioning in progress	Positioning in progress	XF	Channel 7	Operation error	Operation error
	For limit switch output	For positioning																																																			
		Speed switching format	Speed stepping format	Acceleration/Deceleration control format																																																	
X8	Channel 0	FWD	FWD/Low-speed	FWD																																																	
X9	Channel 1	RVS	RVS/Low-speed	RVS																																																	
XA	Channel 2	High-speed	High-speed	Not used																																																	
XB	Channel 3	Low-speed	Medium-speed	Not used																																																	
XC	Channel 4	Brake release	Brake release	Brake release																																																	
XD	Channel 5	In-position	In-position	In-position																																																	
XE	Channel 6	Positioning in progress	Positioning in progress	Positioning in progress																																																	
XF	Channel 7	Operation error	Operation error	Operation error																																																	
		○	×																																																		
Signal outputs from PC CPU	Y10	PLC ready	ON	OFF	Online/offline status is designated by this signal																																																
	Y11	Positioning START	○	×	Detected at leading edge																																																
	Y12	Positioning STOP	○	×																																																	
	Y13	FWD (Forward) JOG (operation occurs when ON)	○	×																																																	
	Y14	RVS (Reverse) JOG (operation occurs when ON)	○	×																																																	
	Y15	Limit switch output enabled	○	×																																																	
	Y16	Error reset	○	○	Detected at leading edge																																																
	Y17	Current position preset 1 prohibit/ current position preset command	○	×	Detected at leading edge																																																
	Y18	Current position preset 2 prohibit	○	×																																																	

○ : Function enabled    × : Function disabled    2/4

Signal type	VS-QA62 (online/offline)		Online	Offline	Remarks
	Address and name				
Buffer memory	0, 1	Current position value (scaling binary)	○	○	
	2, 3	Current position value (sensor binary)	○	○	
	4	Limit switch output status	○	×	Equivalent to external output
	5	Limit switch writing command answerback	○	○	
	6	Input status	○	○	
	7	Error code	○	○	
	8	Limit switch output disabled setting	○	×	
	9	Limit switch writing command	○	○	
	10, 11	Target stop position setting data (scaling binary)	○	×	
	12	Limit switch output selection when positioning	○	○	
	14   365	Channel 0 to 15: limit switch ON/OFF position settings	○	○	
	367, 368	Maximum speed	○	×	
	369	Speed limit	○	×	
	370, 371	Maximum speed reach timer	○	×	
	372	Bias speed when positioning starts	○	×	
	373, 374	Speed command ON delay timer	○	×	
	375, 376	Brake release ON delay timer	○	×	
	377, 378	Deceleration timer	○	×	
	379, 380	Brake release OFF zone	○	×	
	381, 382	Creep zone	○	×	
	383, 384	FWD stop zone	○	×	
	385, 386	RVS stop zone	○	×	
	387	Creep speed	○	×	
	388, 389	Stop timer	○	×	
	390	Deceleration end speed	○	×	
	391, 392	Reverse delay time	○	×	
	393	Initialization command of 'stop zone after learning'	○	×	
	668, 669	Speed output	○	○	
	670, 671	Hold current position (scaling binary)	○	○	
	672, 673	Hold current position (sensor binary)	○	○	
	674, 675	FWD stop zone after learning	○	×	
	676, 677	RVS stop zone after learning	○	×	
	678	Speed limit	○	×	
	679	Positioning pattern data buffer memory selection	○	×	
	680, 681	Medium-speed zone	○	×	
	682, 683	Low-speed zone	○	×	
	684, 685	FWD stop zone	○	×	
	686, 687	RVS stop zone	○	×	
	688, 689	In-position zone	○	×	
	690, 691	Current position preset value 1	○	×	
692, 693	Current position preset value 2	○	×		
696	Positioning output status	○	×		
697	Speed command (with sign)	○	×		
698	Speed command (absolute value)	○	×		

○ : Function enabled    × : Function disabled    3/4

Signal type	VS-QA62 (online/offline)		Online	Offline	Remarks
	Address and name				
Buffer memory	700	Data memory flag	×	○	
	701	Data memory flag answerback	×	○	
	702	Sensor rotation direction	×	○	
	704, 705	Scale length	×	○	
	706, 707	Minimum current position value	×	○	
	708, 709	Current position value	×	○	
	710	Current position change command	×	○	
	711	Output signal selection	×	○	
	712	Positioning format	×	○	
	713	Positioning direction	×	○	
	714, 715	Overshoot amount	×	○	
	716, 717	Medium-speed zone	×	○	
	718, 719	Low-speed zone	×	○	
	720, 721	Stop zone	×	○	
	722, 723	In-position zone	×	○	
	724, 725	Upper limit value	×	○	
	726, 727	Lower limit value	×	○	
	728	Start from stop zone	×	○	
	729	Motion non-detection timer	×	○	
	730	Motion misdirection non-detection timer	×	○	
	731	Positioning end detection timer	×	○	
	732	JOG low-speed timer	×	○	
	733	Offline channel output status	×	○	
	734, 735	Pulse output count setting value	×	○	
	736, 737	Permissible current position change amount	×	○	
	738, 739	Permissible correction amount	×	○	
	740, 741	FWD current position preset value 1	×	○	
	742, 743	RVS current position preset value 1	×	○	
	744, 745	FWD current position preset value 2	×	○	
	746, 747	RVS current position preset value 2	×	○	
	748	Current position preset function	×	○	
	749	Speed gate time	×	○	
	750	Speed sampling time	×	○	
751	Analog output data selection	×	○		
752, 753	Maximum output voltage	×	○		
754, 755	Minimum output voltage	×	○		
756, 757	Maximum output value	×	○		
758, 759	Minimum output value	×	○		
760	JOG low-speed	×	○		
761	JOG high-speed	×	○		

○ : Function enabled    × : Function disabled    4/4

Signal type	VS-QA62 (online/offline)					Online	Offline	Remarks	
	Connector pin No. & Signal name								
	Pin No.	For limit switch output	Speed switching format	Speed stepping format	Acceleration /Deceleration format				
External outputs	1	CH.0	FWD	FWD/low-speed	FWD	○	×	The 'limit switch output status when offline' can be selected by the parameter settings.	
	2	CH.1	RVS	RVS/low-speed	RVS	○	×		
	3	CH.2	High-speed	High-speed	Not used	○	×		
	4	CH.3	Low-speed	Medium-speed	Not used	○	×		
	5	CH.4	Brake release				○		×
	6	CH.5	In-position *1				○		×
	7	CH.6	Positioning in progress *1				○		×
	8	CH.7	Operation error *1				○		×
	20, 21	A phase pulse signal					○	○	
	18, 19	B phase pulse signal					○	○	
	13, 26	Analog signal					○	○	
External inputs	9	Current position preset input 1					○	×	
	10	Current position preset input 2					○	×	

\*1: The signal can be switched to the limit switch output signal by the 'limit switch output selection when positioning' of the buffer memory (Address 12).



APPENDIX 10 DATA SHEET

Appendix 10.1 Initial Setting and Parameter Setting Sheet

Appendix 10.1.1 Initial setting

Initial setting							
Address	Item	Default value	Setting value	Address	Item	Default value	Setting value
702	Sensor rotation direction 0→ CW 1→ CCW	0		704	Scale length (→L) [ 1000~999999 ]	131072	
				705			
				706	Minimum current position value (→K) [ -99999~1000000-L ]	0	
707							
				708	Current position value [ K~(K+L-1) ]	65536	
				709			

Appendix 10.1.2 Parameter setting

Parameter							
Address	Item	Default value	Setting value	Address	Item	Default value	Setting value
711	Output signal selection 0→ Positioning output 1→ Limit switch output 2→ Current position detection	2		736	Permissible current position change amount [ 0 to 999999 ]	999999	
				737			
				738	Permissible correction amount [ 0 to 999999 ]	999999	
				739			
712	Positioning format 0→ Speed switching format (2-speed) without learning function 1→ Speed stepping format (3-speed) without learning function 2→ Speed switching format (2-speed) with learning function 3→ Speed stepping format (3-speed) with learning function 4→ Acceleration/Deceleration control format without learning function 5→ Acceleration/Deceleration control format with learning function	0		740	FWD current position preset value 1 [ K to (K+L-1) ]	0	
				741			
				742	RVS current position preset value 1 [ K to (K+L-1) ]	0	
				743			
713	Positioning direction 0→ FWD direction 1→ RVS direction	0		744	FWD current position preset value 2 [ K to (K+L-1) ]	0	
				745			
714	Overshoot amount [ 0 to 999999 ]	100		746	RVS current position preset value 2 [ K to (K+L-1) ]	0	
715							
716	Medium-speed zone [ 0 to 999999 ]	10000		748	Current position preset function 0→ Disabled 1→ Parameter format 2→ Buffer memory format 3→ Sequence format	0	
717							
718	Low-speed zone [ 0 to 999999 ]	1000					
719							
720	Stop zone [ 0 to 999999 ]	100					
721							
722	In-position zone [ 0 to 999999 ]	100		749	Speed gate time 0→ 0.8ms 1→ 1.6ms 2→ 3.2ms 3→ 6.4ms 4→12.8ms 5→ 25.6ms 6→ 51.2ms 7→ Rotation speed (r/min) 8→ Travel speed (scale value/s)	0	
723							
724	Upper limit value [ -99999 to 999999 ]	999999					
725							
726	Lower limit value [ -99999 to 999999 ]	-99999					
727							
728	Start from stop zone 0→ Disable 1→ Enable	1		750	Speed sampling time 0→ Same as speed gate time 1→ 1/2 of speed gate time 2→ 1/4 of speed gate time	0	
729	Motion non-detection timer [ 0.00 to 99.99 ] (s)	1000		751	Analog output data selection 0→ No output 1→ Absolute value speed command 2→ Speed command 3→ Current speed 4→ Current position	0	
730	Motion misdirection non-detection timer [ 0.00 to 99.99 ] (s)	1000					
731	Positioning end detection timer [ 0.00 to 99.99 ] (s)	10		752	Maximum output voltage (Vmax) [ Vmin to 10.00 ] (V)	1000	
				753			
732	JOG low-speed timer [ 0.00 to 99.99 ] (s)	9999		754	Minimum output voltage (Vmin) [ -10.00 to Vmax ] (V)	0	
				755			
733	Offline channel output status 0→ All-points OFF 1→ Hold	0		756	Maximum output value [ -999999 to 999999 ]	100	
				757			
734 735	Pulse output count setting value [ 1 to 131072 ]	32768		758	Minimum output value [ -999999 to 999999 ]	0	
				759			
				760	JOG low-speed [ 0 to 100 ] (%)	10	
				761	JOG high-speed [ 0 to 100 ] (%)	10	

Appendix 10.2 Limit Switch Data Sheet

Appendix 10.2.1 CH. 0 to CH. 3

Name	CH.0		CH.1		CH.2		CH.3	
Item	Address	Setting value	Address	Setting value	Address	Setting value	Address	Setting value
Number of Multi-dogs	14(L)		36(L)		58(L)		80(L)	
	15(H)		37(H)		59(H)		81(H)	
Dog No.0 ON	16(L)		38(L)		60(L)		82(L)	
	17(H)		39(H)		61(H)		83(H)	
Dog No. 0 OFF	18(L)		40(L)		62(L)		84(L)	
	19(H)		41(H)		63(H)		85(H)	
Dog No.1 ON	20(L)		42(L)		64(L)		86(L)	
	21(H)		43(H)		65(H)		87(H)	
Dog No. 1 OFF	22(L)		44(L)		66(L)		88(L)	
	23(H)		45(H)		67(H)		89(H)	
Dog No.2 ON	24(L)		46(L)		68(L)		90(L)	
	25(H)		47(H)		69(H)		91(H)	
Dog No. 2 OFF	26(L)		48(L)		70(L)		92(L)	
	27(H)		49(H)		71(H)		93(H)	
Dog No.3 ON	28(L)		50(L)		72(L)		94(L)	
	29(H)		51(H)		73(H)		95(H)	
Dog No. 3 OFF	30(L)		52(L)		74(L)		96(L)	
	31(H)		53(H)		75(H)		97(H)	
Dog No.4 ON	32(L)		54(L)		76(L)		98(L)	
	33(H)		55(H)		77(H)		99(H)	
Dog No. 4 OFF	34(L)		56(L)		78(L)		100(L)	
	35(H)		57(H)		79(H)		101(H)	

Appendix 10.2.2 CH. 4 to CH. 7

Name	CH.4		CH.5		CH.6		CH.7	
Item	Address	Setting value	Address	Setting value	Address	Setting value	Address	Setting value
Number of Multi-dogs	102(L)		124(L)		146(L)		168(L)	
	103(H)		125(H)		147(H)		169(H)	
Dog No.0 ON	104(L)		126(L)		148(L)		170(L)	
	105(H)		127(H)		149(H)		171(H)	
Dog No. 0 OFF	106(L)		128(L)		150(L)		172(L)	
	107(H)		129(H)		151(H)		173(H)	
Dog No.1 ON	108(L)		130(L)		152(L)		174(L)	
	109(H)		131(H)		153(H)		175(H)	
Dog No. 1 OFF	110(L)		132(L)		154(L)		176(L)	
	111(H)		133(H)		155(H)		177(H)	
Dog No.2 ON	112(L)		134(L)		156(L)		178(L)	
	113(H)		135(H)		157(H)		179(H)	
Dog No. 2 OFF	114(L)		136(L)		158(L)		180(L)	
	115(H)		137(H)		159(H)		181(H)	
Dog No.3 ON	116(L)		138(L)		160(L)		182(L)	
	117(H)		139(H)		161(H)		183(H)	
Dog No. 3 OFF	118(L)		140(L)		162(L)		184(L)	
	119(H)		141(H)		163(H)		185(H)	
Dog No.4 ON	120(L)		142(L)		164(L)		186(L)	
	121(H)		143(H)		165(H)		187(H)	
Dog No. 4 OFF	122(L)		144(L)		166(L)		188(L)	
	123(H)		145(H)		167(H)		189(H)	

**Appendix 10.2.3 CH. 8 to CH. 11**

Name	CH.8		CH.9		CH.10		CH.11	
Item	CH.8		CH.9		CH.10		CH.11	
	Address	Setting value	Address	Setting value	Address	Setting value	Address	Setting value
Number of Multi-dogs	190(L)		212(L)		234(L)		256(L)	
	191(H)		213(H)		235(H)		257(H)	
Dog No.0 ON	192(L)		214(L)		236(L)		258(L)	
	193(H)		215(H)		237(H)		259(H)	
Dog No. 0 OFF	194(L)		216(L)		238(L)		260(L)	
	195(H)		217(H)		239(H)		261(H)	
Dog No.1 ON	196(L)		218(L)		240(L)		262(L)	
	197(H)		219(H)		241(H)		263(H)	
Dog No. 1 OFF	198(L)		220(L)		242(L)		264(L)	
	199(H)		221(H)		243(H)		265(H)	
Dog No.2 ON	200(L)		222(L)		244(L)		266(L)	
	201(H)		223(H)		245(H)		267(H)	
Dog No. 2 OFF	202(L)		224(L)		246(L)		268(L)	
	203(H)		225(H)		247(H)		269(H)	
Dog No.3 ON	204(L)		226(L)		248(L)		270(L)	
	205(H)		227(H)		249(H)		271(H)	
Dog No. 3 OFF	206(L)		228(L)		250(L)		272(L)	
	207(H)		229(H)		251(H)		273(H)	
Dog No.4 ON	208(L)		230(L)		252(L)		274(L)	
	209(H)		231(H)		253(H)		275(H)	
Dog No. 4 OFF	210(L)		232(L)		254(L)		276(L)	
	211(H)		233(H)		255(H)		277(H)	

**Appendix 10.2.4 CH. 12 to CH. 15**

Name	CH.12		CH.13		CH.14		CH.15	
Item	CH.12		CH.13		CH.14		CH.15	
	Address	Setting value	Address	Setting value	Address	Setting value	Address	Setting value
Number of Multi-dogs	278(L)		300(L)		322(L)		344(L)	
	279(H)		301(H)		323(H)		345(H)	
Dog No.0 ON	280(L)		302(L)		324(L)		346(L)	
	281(H)		303(H)		325(H)		347(H)	
Dog No. 0 OFF	282(L)		304(L)		326(L)		348(L)	
	283(H)		305(H)		327(H)		349(H)	
Dog No.1 ON	284(L)		306(L)		328(L)		350(L)	
	285(H)		307(H)		329(H)		351(H)	
Dog No. 1 OFF	286(L)		308(L)		330(L)		352(L)	
	287(H)		309(H)		331(H)		353(H)	
Dog No.2 ON	288(L)		310(L)		332(L)		354(L)	
	289(H)		311(H)		333(H)		355(H)	
Dog No. 2 OFF	290(L)		312(L)		334(L)		356(L)	
	291(H)		313(H)		335(H)		357(H)	
Dog No.3 ON	292(L)		314(L)		336(L)		358(L)	
	293(H)		315(H)		337(H)		359(H)	
Dog No. 3 OFF	294(L)		316(L)		338(L)		360(L)	
	295(H)		317(H)		339(H)		361(H)	
Dog No.4 ON	296(L)		318(L)		340(L)		362(L)	
	297(H)		319(H)		341(H)		363(H)	
Dog No. 4 OFF	298(L)		320(L)		342(L)		364(L)	
	299(H)		321(H)		343(H)		365(H)	





NSD Group

---

**Manufacturer**

**NSD Corporation** 3-31-28, OSU, NAKA-KU, NAGOYA, JAPAN 460-8302

**Distributor**

**NSD Trading Corporation** 3-31-23, OSU, NAKA-KU, NAGOYA, JAPAN 460-8302

Phone: +81-52-261-2352 Facsimile: +81-52-252-0522

URL: [www.nsdcorp.com](http://www.nsdcorp.com) E-mail: [foreign@nsdcorp.com](mailto:foreign@nsdcorp.com)

Copyright©2024 NSD Corporation All rights reserved.