



ZEF006083301

MELSEC-Q PLC Module Converter

VS-QA262B-LC

User's Manual

Applicable sensor:

CYLNUC cylinder
VLS-12.8
IRS-51.2P



CONTENTS

SAFETY PRECAUTIONS	i
INTRODUCTION.....	iv
TRADEMARKS	iv
REVISION HISTORY	v
1. OVERVIEW	1
1.1 Features	3
1.2 Definitions.....	3
2. SYSTEM CONFIGURATION.....	5
2.1 Overall Configuration.....	5
2.2 Applicable System	6
2.3 Function Block Diagram.....	6
3. VS-QA262B SPECIFICATIONS	7
3.1 General Specifications.....	7
3.2 Performance Specifications.....	8
3.3 Function List	8
3.4 Input/Output Signals between VS-QA262B and PLC CPU.....	9
3.4.1 Input/output signal details	10
3.5 Buffer Memory.....	12
3.5.1 Sensor value storage area.....	12
3.5.2 Current position value storage area	13
3.5.3 Input status storage area	13
3.5.4 Error code storage area	13
3.5.5 Current position setting value storage area.....	14
3.5.6 Current position setting "disabled" area	14
3.5.7 Axis enabled/disabled setting area	14
4 HANDLING and WIRING	15
4.1 VS-QA262B Handling Precautions.....	15
4.2 Wiring Precautions for ABSOCODER Cables	16
4.3 ABSOCODER Sensor Installation Precautions	16
4.3.1 Installation of ABSOCODER sensor	16
4.3.2 Precautions for connecting ABSOCODER sensors.....	16
4.4 Name of Parts.....	17
5. CURRENT POSITION DETECTION FUNCTION	19
5.1 Function Description.....	19
5.1.1 Current position detection function.....	19
5.1.2 Current position setting function.....	20
5.2 Pre-Operation Setting Sequence.....	22
5.3 Programming.....	23
5.3.1 Program creation precautions.....	23
5.3.2 Program for current position monitor display.....	24
5.3.3 Program for error code readout and reset.....	25
5.3.4 Remote I/O station programming	27
6. TROUBLESHOOTING	29
6.1 Error Code List.....	29
6.2 Troubleshooting Flowchart.....	31
6.3 Flowchart when Current Position Setting is Impossible	32
6.4 Flowchart when the ABSOCODER Sensor's Current Position Value doesn't Change	33
APPENDIX 1 CE MARKING	35
APPENDIX 2 UL STANDARD	36

APPENDIX 3 KC MARK	37
APPENDIX 4 ABSOCODER SENSOR SPECIFICATIONS	39
Appendix 4.1 ABSOCODER Sensor for VS-QA262B-LC	39
Appendix 4.1.1 Specifications	39
Appendix 4.1.2 ABSOCODER Sensor Dimensions	39
Appendix 4.2 ABSOCODER Cable	39
Appendix 4.2.1 Specifications	39
Appendix 4.2.2 Cable length restrictions	39
Appendix 4.2.3 ABSOCODER Cable Dimensions	40
Appendix 4.2.4 ABSOCODER Cable Connection	41
APPENDIX 5 DIMENSIONS	42
Appendix 5.1 VS-QA262B Position Detection Module	42
APPENDIX 6 ABSOCODER SENSOR CHECK LIST	43
APPENDIX 7 I/O SIGNALS and BUFFER MEMORY FUNCTION LIST	45

SAFETY PRECAUTIONS

(Read these precautions before using this product.)

Before using this product, please read this manual and the relevant manuals carefully and pay full attention to safety to handle the product correctly.

The precautions given in this manual are concerned with this product only. For the safety precautions of the programmable controller system, refer to the CPU module user's manual.

In this manual, the safety precautions are classified into two levels: "WARNING" and "CAUTION".



WARNING

Procedures which may lead to a dangerous condition and cause death or serious injury if not carried out properly.



CAUTION

Procedures which may lead to a dangerous condition and cause superficial to medium injury, or physical damage only, if not carried out properly.

Under some circumstances, failure to observe the precautions given under "  CAUTION" may lead to serious consequences.

Observe the precautions of both levels because they are important for personal and system safety.

Make sure that the end users read this manual and then keep the manual in a safe place for future reference.

[Application Limitation]

This product is not designed to be used under any situation affecting human life. When you are considering using this product for special purposes such as medical equipment, aerospace equipment, nuclear power control systems, traffic systems, and etc., please consult with NSD.

This product is designed to be used under the industrial environments categorized in Class A device. The supplier and user may be required to take appropriate measures.

[Design Precautions]



WARNING

- Provide an external safety circuit so that the entire system functions safely even when the external power supply or the CPU module is faulty.

Failure to do so may lead to incorrect output or malfunction, resulting in an accident.

- (1) Provide an external circuit of PLC emergency stop circuit and an interlock circuit to prevent the machine from being damaged (e.g. position detection upper and lower limits).
- (2) When this module detects an error, all output signals may turn OFF depending on the type of the error. Provide an external fail safe circuit.
- (3) Output may remain ON or OFF depending on failure of external output devices, such as a transistor. Provide a circuit that can be monitored externally for output signals that may result in serious accidents.



CAUTION

- Do not bind or close the control cable and the communication cable with the main circuit cable and the power cable. Keep the former cables at least 300 mm or more away from the latter cables.

Failure to do so may result in malfunction due to noise.

[Installation Precautions]



CAUTION

- Use the programmable controller in an environment that meets the general specifications contained in the CPU User's Manual.
Failure to do so may result in electrical shock, fire, malfunction, product damage, or deterioration of performance.
- Install the module while pressing the mounting lever at the bottom of module, verifying that the module's mounting protuberance is properly inserted into the base unit's mounting hole.
Failure to do so may result in malfunction, failure, or this module falling.
For use in vibratory environment, tighten the module with screws.
Tighten the screws within the specified torque range.
Loose screws can cause drops of the screws, short circuit or malfunction.
Overt-tightening screws may damage the screws and/or the module, This can cause drops, short circuit or malfunction.
- Be sure to shut off all power before mounting/removing this module.
Failure to do this could result in equipment damage.
- Never directly touch this module's conductive areas or electrical components, because this can cause this module to malfunction or failure.
- Firmly connect the sensor connector to this module's connector.
Failure to do so may result in poor contact, leading to incorrect input and output.

[Wiring Precautions]



CAUTION

- Be sure to shut off all power before wiring.
Failure to do so may result in electrical shock, or equipment damage.
- Do not allow any foreign object (e.g. cutting chips, wire strips) to get into this module.
Failure to do so may result in fire, failure, or malfunction.

[Start-up and Maintenance Precautions]

WARNING

- Be sure to shut off all power before cleaning this module or tightening screws. Failure to do so may result in failure or malfunction of this module. Loose screws can cause drops of the screws, short circuit or malfunction. Overt-tightening screws may damage the screws and/or the module, This can cause drops, short circuit or malfunction.

CAUTION

- Do not disassemble, or modify this module. Failure to do so may result in failure, malfunction, injury, or fire.
- Be sure to shut off all power before mounting/removing this module. Failure to do this could result in failure or malfunction of this module.
- Do not mount/remove the module to/from the base unit more than 50 times after the first use of the product. (IEC 61131-2 compliant) Failure to do so may cause malfunction.
- Before starting test operation, set the parameter speed limit value to the slowest value, and make sure that operation can be stopped immediately if a hazardous state occurs.
- Always make sure to touch a grounded metal to discharge the static electricity from your body, etc., before touching the module. Failure to do so may cause a failure or malfunctions of this module.

[Disposal Precautions]

CAUTION

- Be sure to handle this module as industrial waste when disposing of it.

INTRODUCTION

Thank you for purchasing the VS-QA262B module.

Always read through this manual, and fully comprehend the functions and performance of VS-QA262B before starting use to ensure correct usage of this product.

Please submit this manual to the end user.

TRADEMARKS

MELSEC is the trademark or registered trademark of Mitsubishi Electric Corporation.

Other companies' and products' names are the trademark or registered trademark of each company.

REVISION HISTORY

The document No. appears at the upper right of this manual's cover page.

Document No.	Date	Revision Description
ZEF006083300	28, Jan., 2022	1st Edition Japanese document: ZEF006081600
ZEF006083301	26, Dec., 2022	2nd Edition Japanese document: ZEF006081601

1. OVERVIEW

1. OVERVIEW

This user's manual contains the specifications, and operation/programming procedures for VS-QA262B-LC (*1) which is to be used in combination with a Mitsubishi Electric corp. MELSEC-Q Series programmable controller.

VS-QA262B combines a CYLNUC Cylinder, an actuating Cylinder unit containing a built-in linear position sensor, to detect the position of the machine being controlled.

VS-QA262B is used with the ABSOCODER sensor (cylinder type).

The ABSOCODER sensor is a magnetic position sensor which can replace incremental type encoders which have been widely used until now.

This VS-QA262B and ABSOCODER sensor combination provides an easy and flexible format for machine control.

VS-QA262B can be used to automatically control the position detection of the conveyor, press machine, assembly machine, packing machine, etc.

In addition to main functions (current position detection), VS-QA262B offers a wealth of auxiliary functions.

NOTE *1: VS-QA262B-LC is shown as VS-QA262B on this manual.

*2: Two-axis input/output devices and buffer memory addresses are shown in [].



CAUTION

Cautions concerning when power has been turned OFF or an error has occurred

VS-QA262B-LC detects machine position data in a semi-absolute format.

If the sensor rod position has shifted by more than half the absolute detection pitch in any of the following situations, the module will not be able to obtain a correct current position value.

- Error status is present.
- PLC power has been turned OFF.
- PLC has been reset.

If this happens, find the actual and correct machine position and be sure to correct the current position value using the "Current position setting" function.

For current position setting details, refer to Section 5.1.2, "Current Position Setting Function".

Current Position Detection Function

VS-QA262B's current position detection function detects the current position using an ABSOCODER sensor. Conventionally, this was detected using an incremental format encoder in conjunction with a counter unit.

(1) Operation Example of System with Incremental Format Encoder and Counter

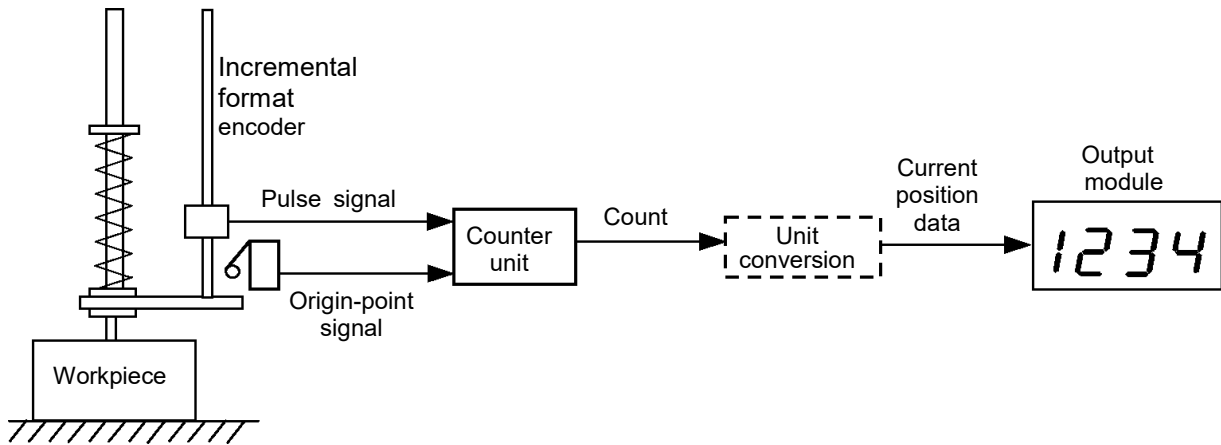

(2) Operation Example of System with VS-QA262B

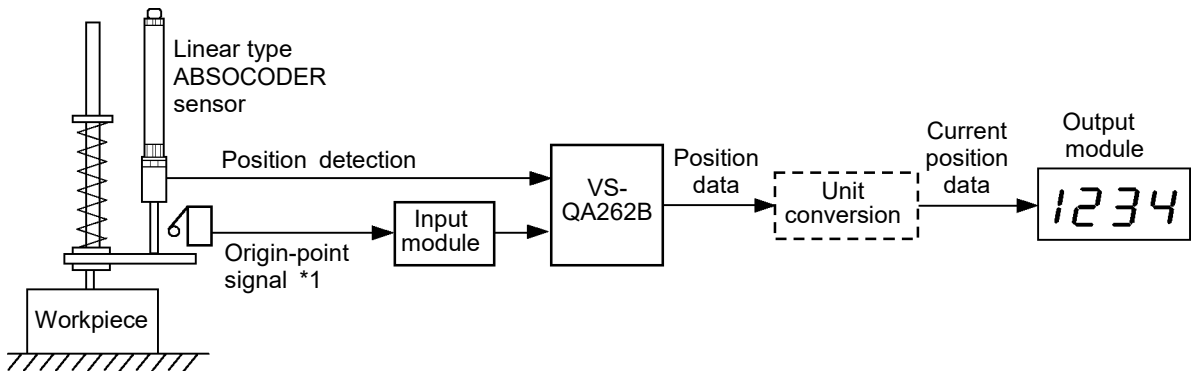

*1: The Origin-point signal input will be used for Current Position Setting Command(Y13 [Y16]).

Fig. 1.1 Example of Current Position Detection Function

1.1 Features

VS-QA262B has the following features:

- (1) Semi-absolute position detection
A specified span (standard pitch) is detected by an absolute position detection method, and the software counts the number of pitches.
- (2) High resolution:
CYLNUC Cylinder (CSA, SBA, SBB, and SBH), rod sensor (VLS-12.8): $1.5625 \mu\text{m}$
In-rod sensor (IRS-51.2P): $6.25 \mu\text{m}$
- (3) High-speed response:
VS-QA262B is not affected by the PLC's scan time. The position detection is executed every 0.4ms.
- (4) Current position setting function:
If a positional discrepancy occurs between the machine's position and the ABSOCODER sensor's position, the current position can be set to the desired value by the output signal (Y13 [Y16]) from the PLC CPU.
- (5) Compliance with UL and CE standards
VS-QA262B complies with both UL (UL508) and CE (EMC Directive) standards, and therefore presents no problems when used in equipment which is to be exported abroad.
- (6) Compliance with KC mark (Korea Certification Mark)
The VS-QA262B complies with KC mark. (It is only certified under the Radio Waves Act of South Korea.)
KC mark is the same directives as CE marking. For more details, refer to "APPENDIX 1 CE marking".

1.2 Definitions

(1) ABSOCODER

ABSOCODER is the generic name given to the NSD-developed position sensor which detects rotational/linear displacement, speed, and acceleration, using an absolute position detection method with a digital (or analog) output.

ABSOCODER consists of two main components:

The sensor, where displacement is detected by the change in magnetic resistance, and the converter, where the sensor's output signal (when an AC excitation signal has been applied to the sensor) is converted into absolute data.

The converter for a cylinder type ABSOCODER sensor is built-in to VS-QA262B.

(2) Sensor travel direction

Depending on the direction in which the ABSOCODER sensor rod (or scale in the case of IRS-51.2P) travels, the position value will increase or decrease.

Current Position Value in CW Direction:

Position data value will increase when the rod (or scale in the case of IRS-51.2P) travels in the CW direction in the figure below.

Current Position Value in CCW Direction:

Position data value will increase when the rod (or scale in the case of IRS-51.2P) travels in the CCW direction in the figure below.

There are two data areas that may be used to obtain a position data from VS-QA262B. For details about the two areas, refer to Section 3.5.2.

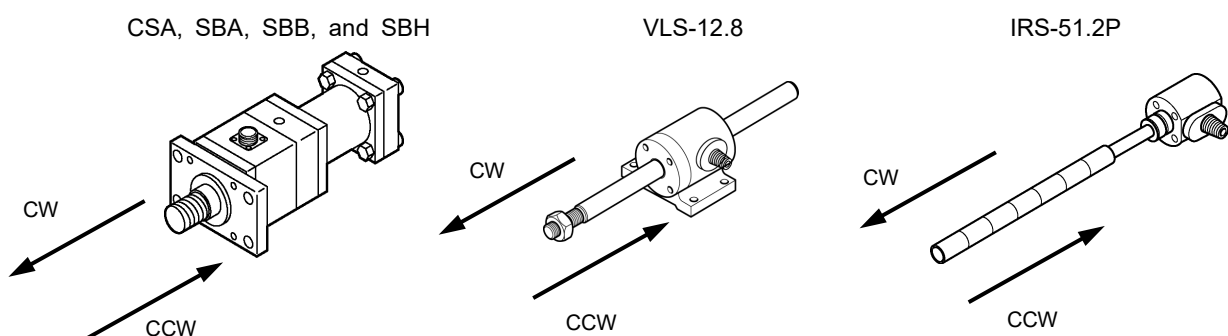

(3) Semi-absolute format

In the semi-absolute format, “standard pitch” of the sensor rod is detected in absolute value. (Absolute detection range)
Furthermore, the pitch is counted by the software.

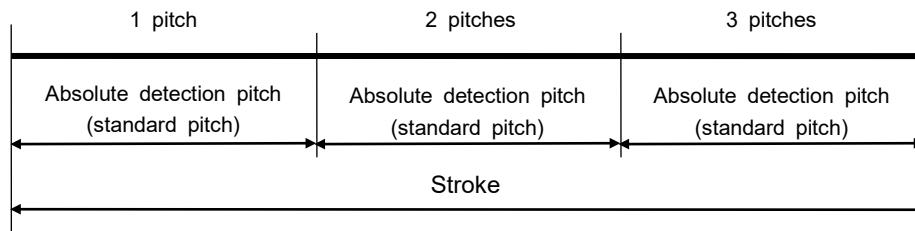

*: The absolute detection range of each sensor is following:
CYLNUC Cylinder(CSA, SBA, SBB, and SBH), rod sensor (VLS-12.8)
Standard pitch: 12.8mm
In-rod sensor (IRS-51.2P)
Standard pitch: 51.2mm

(4) Current position value

This value indicates where the machine is currently positioned within the detection range. This can be expressed in binary code.

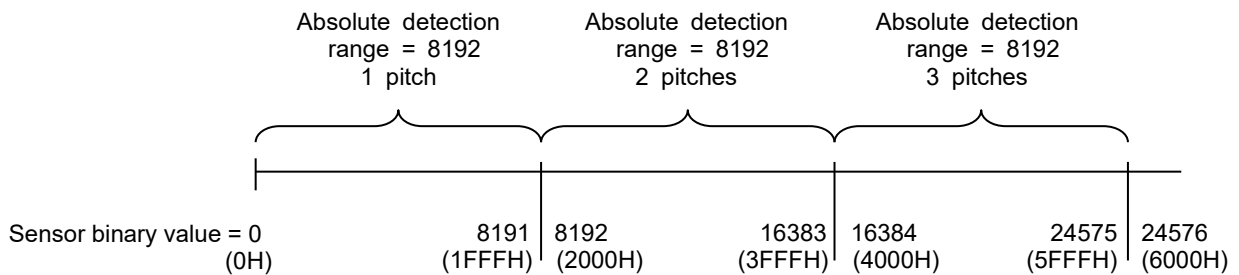

VS-QA262B is capable of counting up to 2048 pitches.
Therefore, the module's entire detection range is 8192 divisions x 2048 pitches.
Detection range: 0 to 16777215 (0 to FFFFFFFH)

2. SYSTEM CONFIGURATION

2. SYSTEM CONFIGURATION

2.1 Overall Configuration

The overall configuration of the Mitsubishi Electric corp. MELSEC-Q Series using VS-QA262B is shown below.

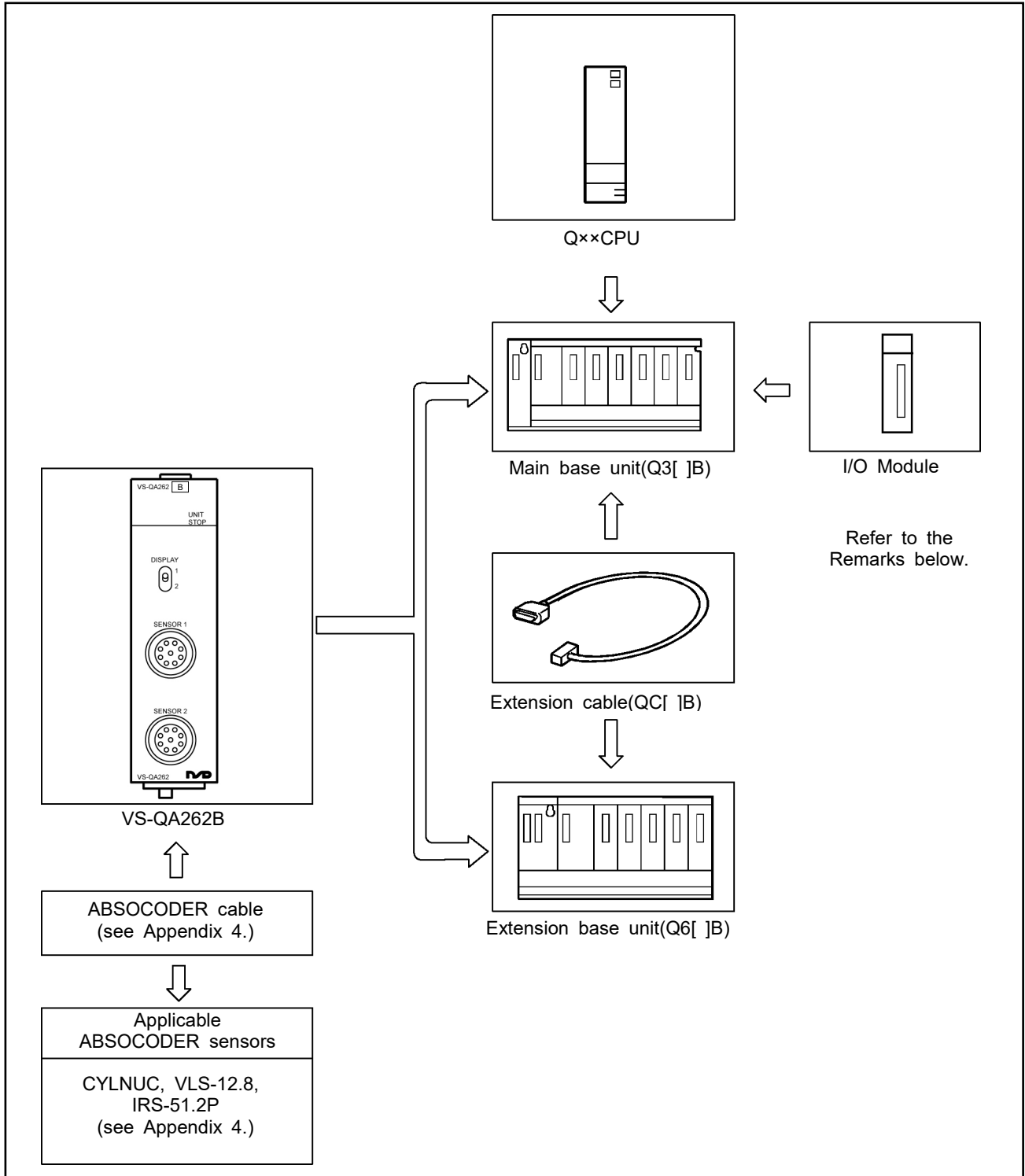

Fig. 2.1 VS-QA262B System Configuration

REMARKS

As VS-QA262B does not have an external input/output circuit, input and output have to be executed using a sequence program. Select and prepare an input/output module according to the required functions.

2.2 Applicable System

VS-QA262B can be used in the following system.

(1) Applicable CPU module

Refer to NSD web site for CPU module models with which VS-QA262B can be used.

(2) Number of mountable modules

Pay attention to the power supply capacity before mounting modules.
Change the combination of the modules if the power supply capacity is insufficient.

(3) Applicable base units

VS-QA262B can be installed to any I/O slot of a base unit.

Remarks

As VS-QA262B does not have an external input/output circuit, input and output have to be executed using the sequence program.

If VS-QA262B is installed to a remote I/O station, it may become impossible to assure response performance.

Be careful when attempting to reduce the sequence scan time effect using a fixed-scan execution type program or high-speed interrupt function.

About fixed-scan execution type programs and high-speed interrupt functions, refer to the User's Manual ('Function Explanation: Program Fundamentals') and/or the Programming Manual for your CPU module.

2.3 Function Block Diagram

Fig. 2.2 shows the block diagram of the VS-QA262B functions.

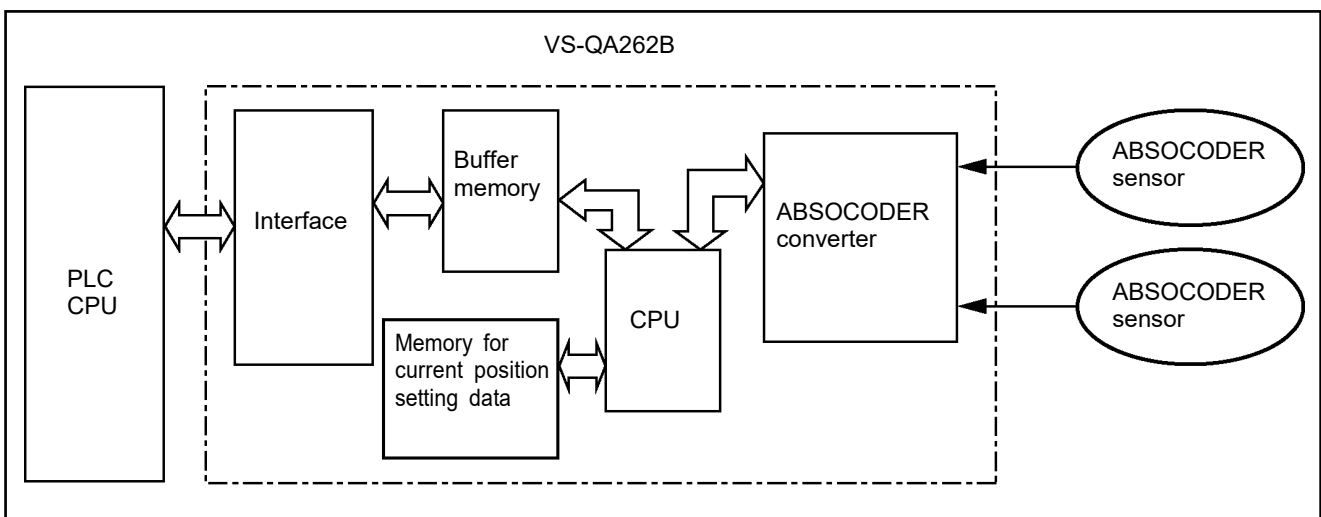

Fig. 2.2 Block Diagram of VS-QA262B Functions

3. VS-QA262B SPECIFICATIONS

3. VS-QA262B SPECIFICATIONS

3.1 General Specifications

Shown below are the VS-QA262B specifications.

About the ABSOCODER sensor specifications, refer to Appendix 4, "ABSOCODER SENSOR SPECIFICATIONS".

Table 3.1 General Specifications

Items	Specifications					
Operating ambient temperature	0 to 55°C					
Storage ambient temperature	-25 to 75°C *3					
Operating ambient humidity	5 to 95%RH *4, non-condensing					
Storage ambient humidity						
Vibration resistance	Compliant with JIS B 3502 and IEC 61131-2		Frequency	Constant acceleration	Half amplitude	Sweep count
		Under intermittent vibration	5 to 8.4Hz	—	3.5mm	10 times each in X, Y, Z directions
			8.4 to 150Hz	9.8m/s ²	—	
		Under continuous vibration	5 to 8.4Hz	—	1.75mm	—
8.4 to 150Hz	4.9m/s ²		—	—		
Shock resistance	Compliant with JIS B 3502 and IEC 61131-2 (147 m/s ² , 3 times each in 3 directions X, Y, Z)					
Operating atmosphere	No corrosive gases					
Operating altitude *5	0 to 2000m					
Installation location	Inside a control panel					
Over voltage category *1	II or less					
Pollution degree *2	2 or less					
Equipment class	Class I					

- *1: This indicates the section of the power supply to which the equipment is assumed to be connected between the public electrical power distribution network and the machinery within premises. Category II applies to equipment for which electrical power is supplied from fixed facilities. The surge voltage withstand level for up to the rated voltage of 300V is 2500V.
- *2: This index indicates the degree to which conductive material is generated in terms of the environment in which the equipment is used. Pollution level 2 is when only non-conductive pollution occurs. A temporary conductivity caused by condensing must be expected occasionally.
- *3: The storage ambient temperature is -20 to 75°C if the system includes the AnS/A series modules.
- *4: The operating ambient humidity and storage ambient humidity are 10 to 90%RH if the system includes the AnS/A series modules.
- *5: Do not use or store the programmable controller under pressure higher than the atmospheric pressure of altitude 0m. Doing so may cause malfunction.

3.2 Performance Specifications

Table 3.2 Performance Specifications

Items		Specifications	Remarks
Number of position detection axes		2	
Position detection method		Semi-absolute format	
Resolution		CYLNUC Cylinder, VLS-12.8: 1.5625 μ m IRS-51.2P: 6.25 μ m	
Total number of divisions		Standard pitch x number of pitches (8192 divisions (2^{13}) x max. 2048 pitches)	
Function		- Current position detection function - Current position setting function	
Sampling time [ms]		0.4	
Response time [ms]	Current position value output signals	0.8	Max. response delay time due to internal processing
No. of occupied I/O points		32	I/O assignment: 32 points for intelligent function module
Internal current consumption (5VDC) [A]		0.7	
Outline dimensions [mm]		98 (H) x 27.4 (W) x 90 (D)	
Mass [kg]		0.2	
Display of module model names in PLC		008 VS-QA262B-LC	
Applicable standard		UL508 CSA C22.2 No.142 (Compliance with c-RU standard) CE Marking (EMC directive) KC mark (Korea Certification Mark)	

3.3 Function List

As shown in table 3.3, VS-QA262B's functions are divided into 2 groups consisting of 'main functions' and 'auxiliary functions'. The main functions of VS-QA262B are useful for actual system control, and the auxiliary functions are to support the main function operations.

Table 3.3 Function List

Function		Description	Reference
Main functions	Current position detection function	The machine position is detected by the ABSOCODER sensor.	Section 5.1.1
Auxiliary functions	Current position setting function	VS-QA262B's Current Position Value is set according to the current and actual machine position of the system.	Section 5.1.2

3.4 Input/Output Signals between VS-QA262B and PLC CPU

Below shows the input and output signals to the PLC CPU.

(1) In the table below, the input/output signals are classified as follows:

- (a) Device X: Input signals from VS-QA262B to PLC CPU.
- (b) Device Y: Output signals from PLC CPU to VS-QA262B.

(2) Input/output signal configuration when VS-QA262B is installed at the base unit's Slot 0.

Signal direction : VS-QA262B → PLC CPU		Signal direction : PLC CPU → VS-QA262B		
Device No.	Signal Name	Device No.	Signal Name	
X 0	Unit ready (VS-QA262B detection item)	Y 0	Use prohibited	
X 1	VS-QA262B operation status (online/offline)	Y 1		
X 2	Use prohibited	Y 2		
X 3		Y 3		
X 4	Axis 1	Sensor error detection		Y 4
X 5		Error detection		Y 5
X 6	Use prohibited	Y 6		
X 7		Y 7		
X 8	Axis 2	Sensor error detection		Y 8
X 9		Error detection		Y 9
X A	Use prohibited	Y A		
X B		Y B		
X C		Y C		
X D		Y D		
X E		Y E		
X F		Y F		
X 10		Y 10		PLC ready
X 11		Y 11		Use prohibited
X 12		Y 12		
X 13		Use prohibited		Y 13
X 14	Y 14		Use prohibited	
X 15	Y 15			
X 16	Use prohibited	Y 16	Axis 2 Current position setting command (Detected at leading edge)	
X 17		Y 17	Use prohibited	
X 18		Y 18		
X 19		Y 19		
X 1A		Y 1A		
X 1B		Y 1B		
X 1C	Y 1C	Error reset (Detected at leading edge)		
X 1D	Y 1D	Use prohibited		
X 1E	Y 1E			
X 1F	Y 1F			

IMPORTANT

VS-QA262B's operation cannot be guaranteed if ON/OFF switching of Y0 to YF, Y11 to Y12, Y14 to Y15, Y17 to Y1B, and Y1D to Y1F is executed by the sequence program.

3.4.1 Input/output signal details

The ON/OFF timing and other conditions for signal input/output between VS-QA262B and PLC CPU are explained below.

(1) Unit ready (X0):

This signal comes OFF when a watchdog timer error is detected by VS-QA262B's self-diagnosis function.

When 'X0' comes OFF, this indicates a VS-QA262B hardware error.

(2) VS-QA262B operation status (outline/offline) (X1):

If the 'PLC ready' signal (Y10) is turned ON by the sequence program, VS-QA262B will be set to an 'online' status, and 'X1' will turn ON.

'X1' will go OFF when 'Y10' is turned OFF.

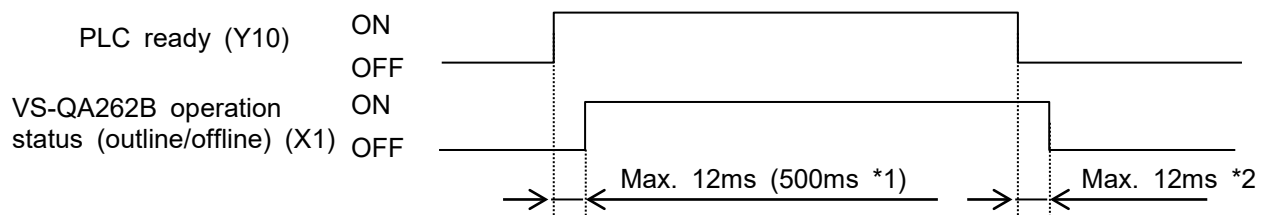

*1: The module cannot go online for a period of 500 ms immediately after the power is turned on or the PLC CPU is reset, even if the "PLC Ready" signal (Y10) is ON.

*2: When connected to a remote I/O, the remote I/O network's transmission delay time will be added to the response time.

(3) Sensor error detection (X4 [X8]):

This signal turns ON when an error occurs in ABSOCODER's position detection system, due to a disconnected ABSOCODER cable, etc.

After the problem has been corrected, 'X4 [X8]' will go OFF when 'Y1C' (error rest signal) is turned ON by the sequence program.

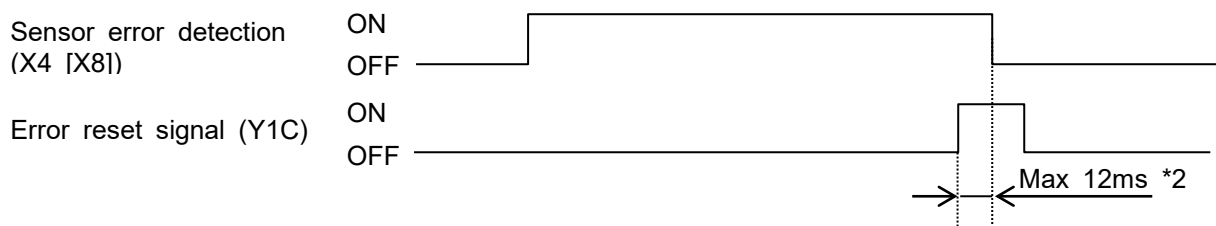

*2: When connected to a remote I/O, the remote I/O network's transmission delay time will be added to the response time.

(4) Error detection (X5 [X9]):

This signal comes ON when any of the 'X4 [X8]' signal comes ON, or when any of the errors shown section 6.1 occur.

'X5 [X9]' will go OFF after the cause of the error has been corrected, and the 'Y1C' (error reset signal) has been turned ON by the sequence program.

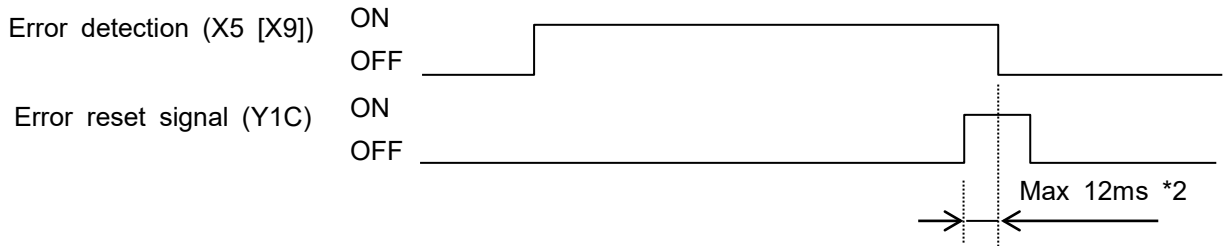

*2: When connected to a remote I/O, the remote I/O network's transmission delay time will be added to the response time.

(5) PLC ready signal (Y10):

This signal is used to switch VS-QA262B's operation status (online/offline).

Y10 ON ... Online

Y10 OFF ... Offline

*: Current position setting cannot be executed at the "offline" status.

(6) Error reset signal (Y1C):

The following error detection signals will be reset after the cause of the error has been corrected, and the 'Y1C' (error reset signal) has been turned ON by the sequence program.

X4 [X8] (Sensor error detection)

X5 [X9] (Error detection)

The error code which has been stored in the buffer memory (Address: 7 [1007]) will also be cleared (0) at this time.

Reset of the error detection signals and clearing of the error codes will be effective when the Y1C status changes from OFF to ON. (Detected at leading edge)

Do not use a pulse instruction for an Error Reset signal (Y1C).

(7) Current position setting command (Y13 [Y16]):

When Y13 [Y16] is turned ON by the sequence program, the current position setting will be executed.

This command is only operative at the "online" status.

3.5 Buffer Memory

VS-QA262B contains a buffer memory which is used for data communication with the PLC CPU. The buffer memory configuration and content is shown below. Data readout of all areas can be executed by the sequence program. Buffer memory space is provided for 2 axes (same content). Addresses 0 to 702 are for Axis 1, and addresses 1000 to 1702 are for Axis 2. The 703 to 999 addresses are not used.

Address (decimal) []: Address for axis 2		Writing Conditions
		When designated by sequence program
0 [1000]	(L) Sensor value (Raw sensor binary value)	Writing disabled
1 [1001]	(H) value	
2 [1002]	(L) Current position value in CW	
3 [1003]	(H) direction (sensor binary)	
4 [1004]	(L) Current position value in CCW	
5 [1005]	(H) direction (sensor binary)	
6 [1006]	Input status	
7 [1007]	Error code	
8 [1008]	Not used	
689 [1689]		
690 [1690]	(L) Current position setting value	Writing enabled at any time
691 [1691]	(H)	
692 [1692]	Not used	
693 [1693]		
694 [1694]	Current position setting "disabled"	Writing enabled at any time
695 [1695]	Not used	
701 [1701]		
702 [1702]	Axis enabled/disabled	Writing enabled at any time

3.5.1 Sensor value storage area

The in-standard-pitch position values detected by the ABSOCODER sensor (raw sensor value) is stored in this area as a binary value.

The position value will increase when the rod (or scale in the case of IRS-51.2P) of the linear ABSOCODER sensor travels in the CW direction as shown below.

The sensor value range is 0 to 8191 (0 to 1FFFH), excluding data of the pitches.

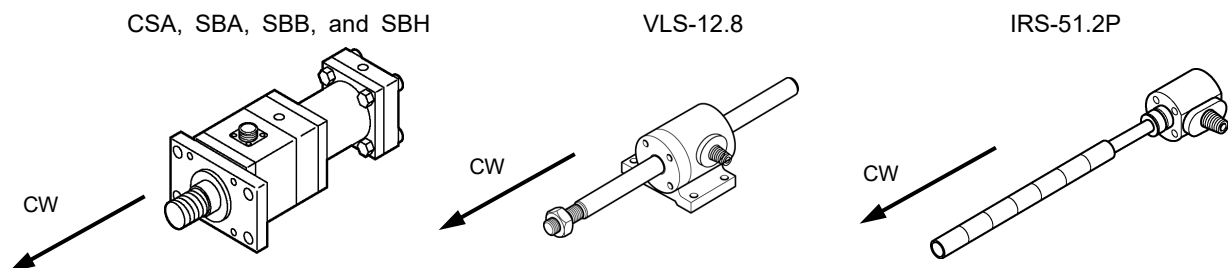

3.5.2 Current position value storage area

The machine's current position is detected by a semi-absolute method, and that position is stored in this area as a sensor binary value.

Two data areas for the current position value, depending on the direction in which the current position value increases, are as follows:

Current Position Value increasing in CW Direction (Address 2, 3 [1002, 1003]):

The current position value will increase when the rod (or scale in the case of IRS-51.2P) travels in the CW direction shown below.

Current Position Value increasing in CCW Direction (Address 4, 5 [1004, 1005]):

The current position value will increase when the rod (or scale in the case of IRS-51.2P) travels in the CCW direction as shown below.

The range for current position value is as follows:

Linear type ABSOCODER: 0 to 16777215 (0 to FFFFFFFH).

This current position value can be corrected using the current position setting function.

For details about the current position setting function, refer to Section 5.1.2.

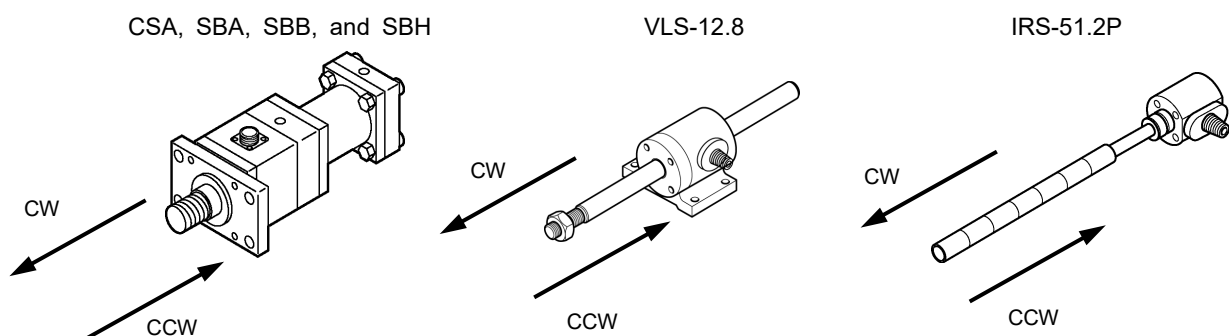

3.5.3 Input status storage area

This area is used to store the input status of the Current position setting command (Y13 [Y16]).

The input status is stored as follows:

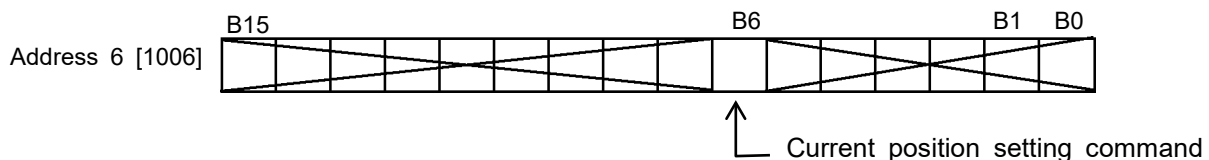

(1) Current position setting command status

When the Current position setting command is ON, '1' is stored.

'0' is stored at the other bits.

3.5.4 Error code storage area

This is the area where error codes are stored when errors occur. (Address 7 [1007])

For error code details, refer to Section 6.1.

(1) Error codes are stored as binary values.

(2) This storage area is cleared by any of the following actions:

(a) When turning the Y1C (error reset) signal ON by the sequence program.

(b) When the PLC CPU is reset.

(c) When the PLC power supply is turned OFF.

3.5.5 Current position setting value storage area

This is the area where the setting value used for current position value setting by CPU output (Y13 [Y16]) is stored. (Address 690, 691 [1690, 1691])

This area can be written at any time by the sequence program.

'0' is automatically stored as default when the PLC CPU is reset or the PLC power supply is turned OFF.

The setting values are written in binary values.

The setting range is 0 to 16777215 (0 to FFFFFFFH). Writing a value out of the range will cause an error.

3.5.6 Current position setting "disabled" area

This area determines whether or not current position setting by CPU output (Y13 [Y16]) is to occur.

This area can be written at any time by the sequence program.

'0' is automatically stored as default when the PLC CPU is reset or the PLC power supply is turned OFF.

(1) Setting is made by designating '0' or '1' to the appropriate bit:

0: Current position setting command enabled

1: Current position setting command disabled

(2) As shown below, only one lower bit is active.

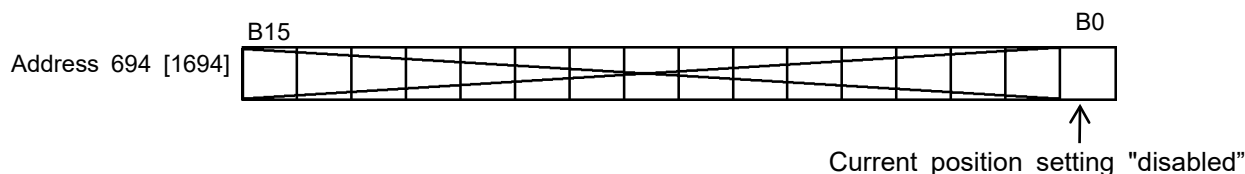

3.5.7 Axis enabled/disabled setting area

This area determines whether to enable or disable a particular axis.

When buffer memory address 702 is set to "99", the axis 1 will be disabled.

When buffer memory address 1702 is set to "99", the axis 2 will be disabled.

This area can be written at any time by the sequence program.

The stored values will not change even after the PLC CPU is reset or the PLC power supply is turned OFF.

The setting values are written in binary values.

0: The subject axis will be enabled (factory setting).

99: The subject axis will be disabled (error will not occur even when the axis is not connected to an ABSOCODER sensor).

CAUTION

When an ABSOCODER sensor is connected to an axis set to "99", all the functions except for error detection will work normally.

If adding a sensor after you have set the subject to "99", be sure to set the axis back to "0". Otherwise, the axis will operate without error detection and will be dangerous.

To use such an axis, be sure to set its Axis enabled/disabled setting to "0".

4. HANDLING and WIRING

4 HANDLING and WIRING

This section explains how to unpack and connect VS-QA262B.

4.1 VS-QA262B Handling Precautions

The following precautions should be observed when handling VS-QA262B.

- (1) As VS-QA262B is constructed from a resin-based material, it should not be dropped or subjected to severe shocks.
- (2) Never remove the PCBs from VS-QA262B's case. Failure to do so may result in failure.
- (3) Turn OFF the PLC power supply before mounting and removing VS-QA262B to and from the base unit.
- (4) During the wiring procedure, do not allow any foreign object (e.g. wire strips, etc.) to get into VS-QA262B.
The top part of VS-QA262B is particularly vulnerable.
- (5) Tighten the VS-QA262B securing screws (M3) within the torque range of 0.36 to 0.48N·m.

4.2 Wiring Precautions for ABSOCODER Cables

The wiring precautions for the ABSOCODER cable are explained in this section.

- (1) The ABSOCODER cable should be located as far as possible from power lines and other lines which generate a high level electrical noise.
- (2) If location near the above power lines is unavoidable, the cable duct should be separated, with individual wiring conduits being provided.
- (3) When wiring conduits are used, they should be securely grounded.

4.3 ABSOCODER Sensor Installation Precautions

The installation conditions and precautions for the ABSOCODER sensor are described in this section.

4.3.1 Installation of ABSOCODER sensor

- 1) Do not apply excessive forces to the cable terminal area, and avoid damaging the cable.
- 2) The part of a machine mounted the sensor rod must travel in the same direction as the sensor rod extends and contracts.
- 3) When the cable port is exposed, a shielding plate should be installed as shown in the right figure.

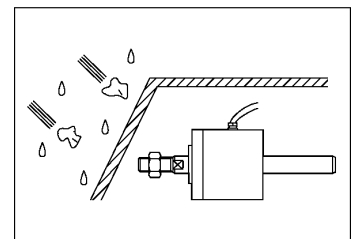
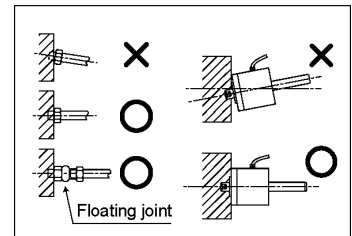
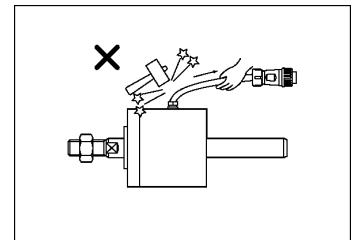

Contact your NSD representative for details of the installation conditions and precautions for ABSOCODER sensor.

4.3.2 Precautions for connecting ABSOCODER sensors

- (1) Connection should be made using the ABSOCODER cable, with the connector being securely tightened.
- (2) If further length is desired, an extension cable must be ordered separately. Refer to Appendix 4.2 for details regarding extension cables.
- (3) The maximum length for which extension is possible varies according to the ABSOCODER sensor model which is used. Refer to Appendix 4.2.2 for details.
- (4) A robotic cable must be used if the ABSOCODER cable is to be used at a movable area of the system. In such a case, the cable should never be bent to from a radius of less than 75mm.

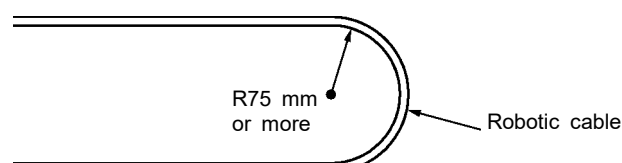

4.4 Name of Parts

The illustration below shows the nomenclature of VS-QA262B.

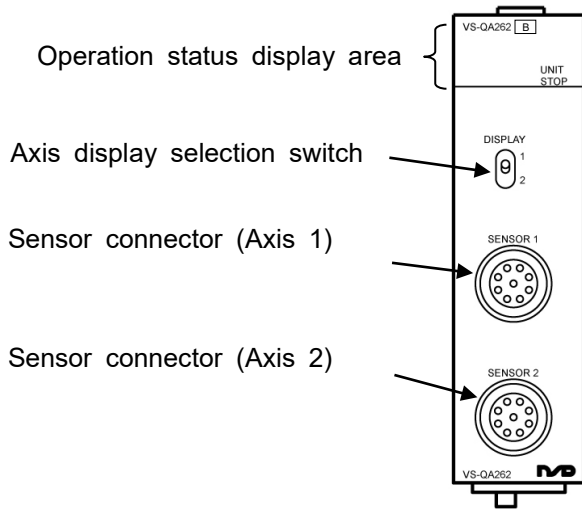

Functions of operation status display area

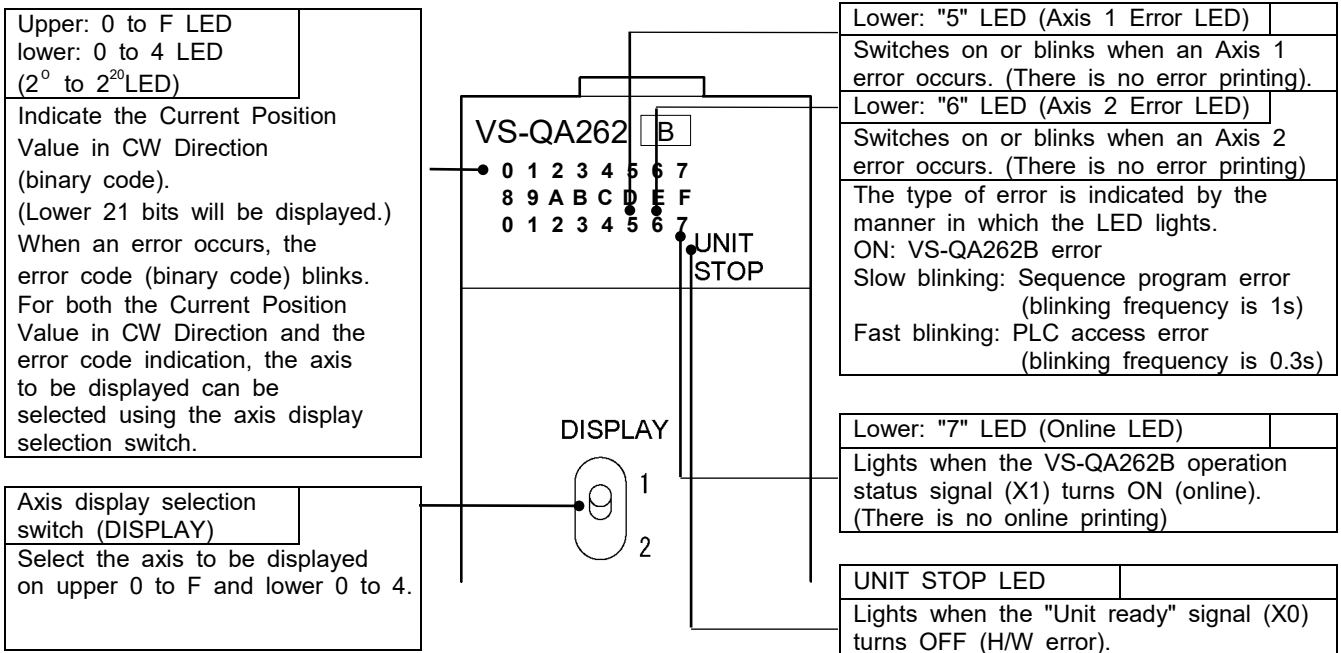

5. CURRENT POSITION DETECTION FUNCTION

5. CURRENT POSITION DETECTION FUNCTION

5.1 Function Description

5.1.1 Current position detection function

VS-QA262B's current position detection function detects the current position using an ABSOCODER sensor. Conventionally, this was detected using an incremental format encoder in conjunction with a counter unit.

As shown in Figure 5.1, a current position value appropriate for the actual machine position detected by the ABSOCODER sensor is stored in the buffer memory.

Fig. 5.1 Example of using VS-QA262B

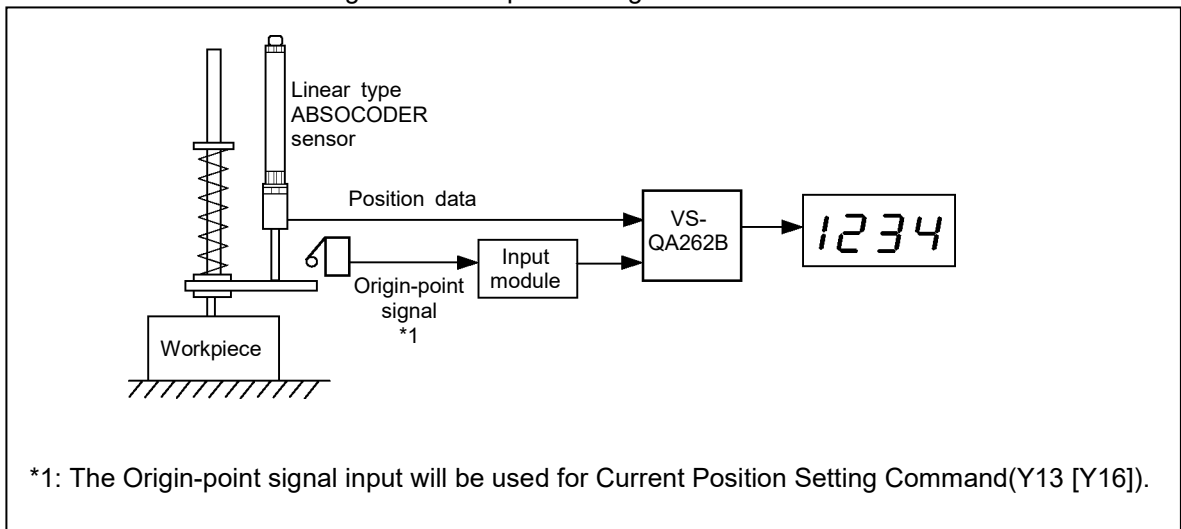

5.1.2 Current position setting function

"Current position setting" is a function to change VS-QA262B's current position value to a value corresponding to the current and actual machine position.

The Current Position Value in CW Direction (Address 2, 3 [1002, 1003]) or the Current Position Value in CCW Direction (Address 4, 5 [1004, 1005]) in buffer memory will be changed to a pre-entered Current Position Setting Value (Address 690, 691 [1690, 1691]).

The following three requirements must be satisfied to enable the current position setting function.

- ① All the sensor errors have been reset.
- ② VS-QA262B is in online status.
- ③ The Current Position Setting Disabled area in buffer memory (Address 694, 695 [1694, 1695]) is set to "0".

Setting procedure

- (1) Write a value corresponding to the current and actual machine position into the buffer memory's Current Position Setting Value area (Address 690, 691 [1690, 1691]).
Refer to 3.5.5 for details about current position setting value.
- (2) Input the current position setting command (Device Y13 [Y16]) from the PLC CPU.
The current position setting command will be detected at the leading edge.
- (3) The Current Position Value in CW Direction or the Current Position Value in CCW Direction in buffer memory will be changed to the given value.

Current position setting timing

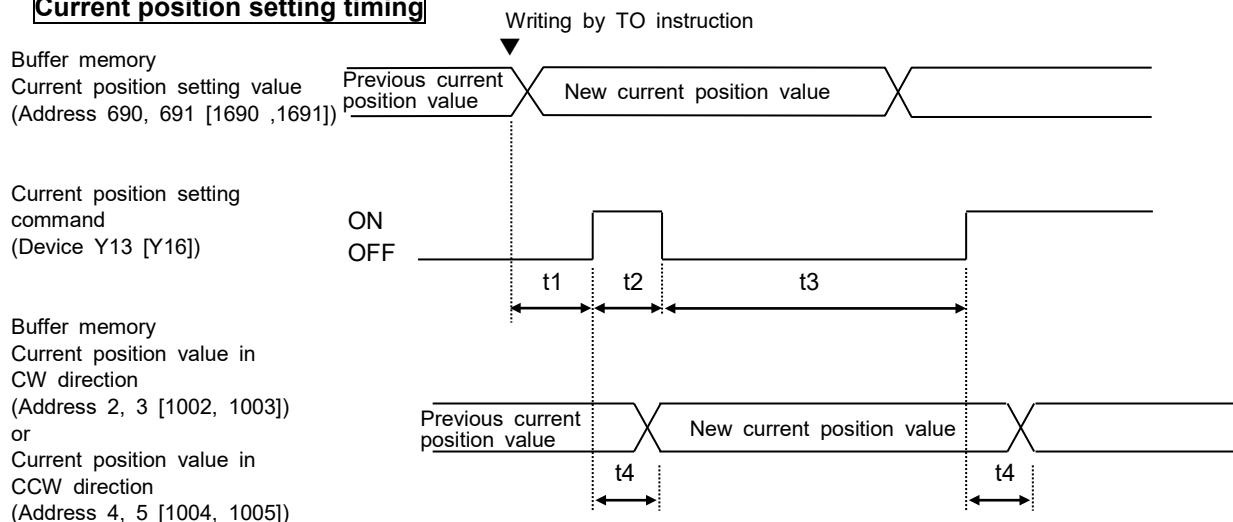

t_1 : Current Position Setting Command Effect Time *1

This is the time required for a Current Position Setting Command to become effective after the current position setting value is written into the buffer memory by a TO command. Be careful that if the Current Position Setting Command signal is turned ON before the Effect Time expires, the current position value may be set back to the old value.
 $t_1 \geq 12\text{ms}$

t_2 : Current Position Setting Command Time

This is the Current Position Setting Command receiving time. Pulse instructions can be used for a Current Position Setting Command (Y13 [Y16]).
 $t_2 \geq \text{Scan time}$

t_3 : Current Position Setting Command Repeat Time

To repeat Current Position Setting Command inputs, the signal must remain OFF for this duration before the second input is made.
 $t_3 \geq 100\text{ms}$

t_4 : Current Position Setting Command Response Time *1

This is the time required for VS-QA262B to be actually set to the new current position value after the Current Position Setting Command signal is turned ON.
 $t_4 \leq 2\text{ms}$

*1: When connected to a remote I/O, the remote I/O network's transmission delay time will be added to the response time.

**CAUTION**Cautions concerning when power has been
turned OFF or an error has occurred

VS-QA262B-LC detects the machine position by a semi-absolute method.

If the sensor rod position has shifted by more than half the absolute detection pitch in any of the following situations, the module will not be able to obtain a correct current position value.

- Error status is present.
- PLC power has been turned OFF.
- PLC has been reset.

If this happens, find the actual and correct machine position and be sure to correct the current position value using the "Current position setting" function.

5.2 Pre-Operation Setting Sequence

This section explains the setting sequence for the current position detection function.

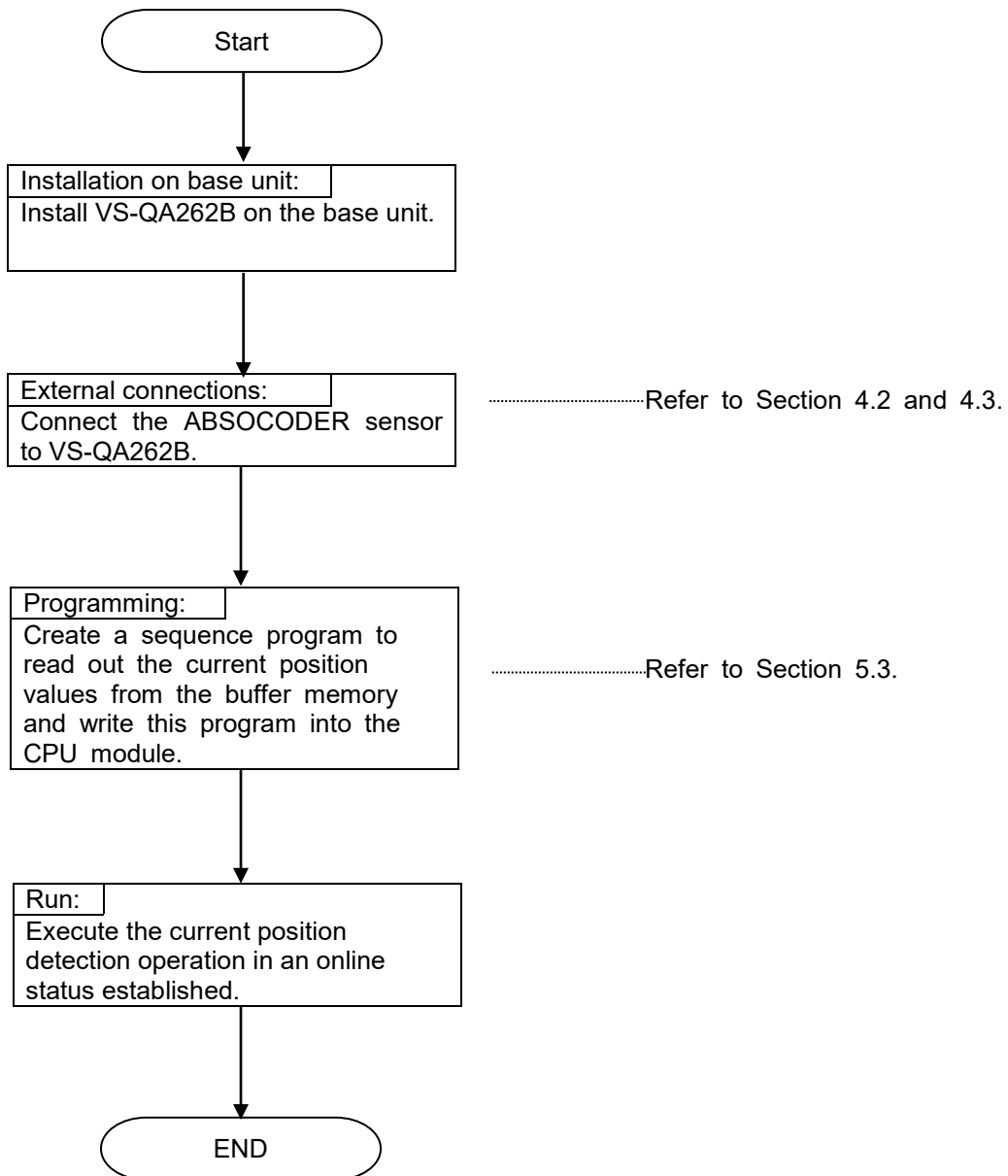

5.3 Programming

This section explains how to create the sequence program using VS-QA262B.

5.3.1 Program creation precautions

- (1) VS-QA262B is an intelligent function module that occupies thirty two I/O points.
- (2) In response to 'FROM/TO' instructions, the first input/output No. of VS-QA262B's slot will be designated.

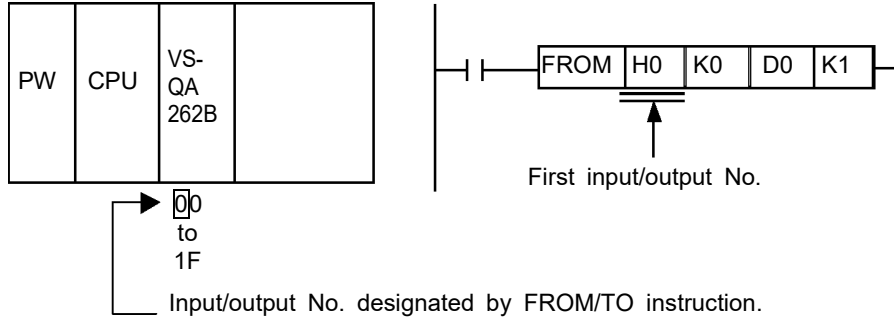

- (3) The following designation enables to execute instructions to VS-QA262B as an intelligent function device.

Designation method: U[] ¥G[]

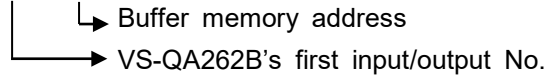

Setting: When the VS-QA262B first input/output No. is expressed as a 3-digit No., the upper 2 digits are specified.
 When the VS-QA262B first input/output No. begins with 0E0, "0E" is specified. (U0E¥G0).

- (4) VS-QA262B control begins when the Y10 signal (PLC ready signal) is turned ON.
- (5) To stop all VS-QA262B control, turn Y10 (PLC ready signal) OFF.
- (6) Error reset:
 It takes 12 ms for VS-QA262B to detect the Y1C signal (error reset) after it has been turned ON.
 Therefore, if the ON period of the Y1C signal is less than 12 ms, it may not be detected, and the 'error detection' signal will not go OFF.
 To prevent this, the following programming method should be used.

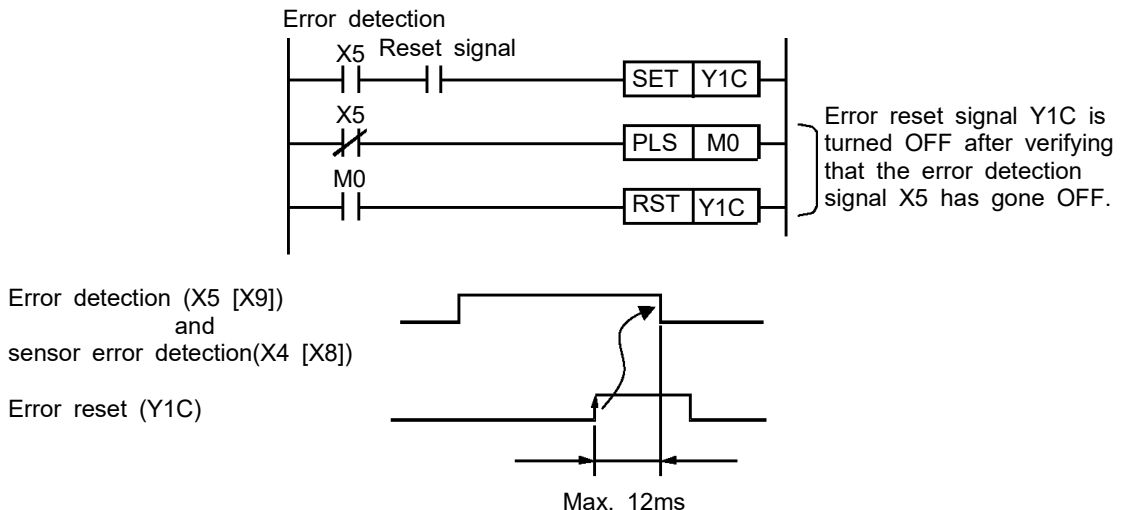

5.3.2 Program for current position monitor display

A program example for the current position monitor display is given below.
 This program example is for Axis 1. Axis 2 programs can be generated in the same way.

Conditions

The following signal assignments are used to control VS-QA262B.

- VS-QA262B 'online' command X32
- Current position value in CW direction (sensor binary) storage register D0, D1
- Current position value in CW direction (sensor binary) output to external display unit Y60 to Y77

Program example

(1) Example of program using FROM/TO instructions

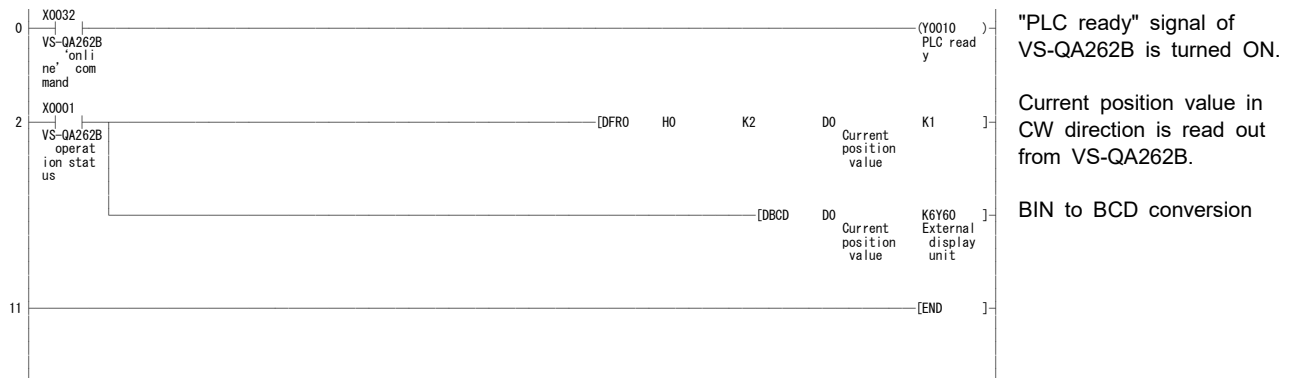

(2) Example of program using an intelligent function device (U[]G[]).

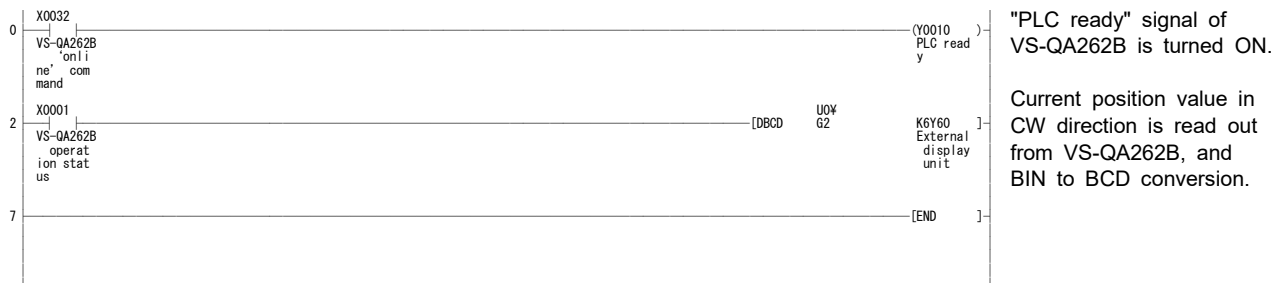

Explanation

- (1) When VS-QA262B is online, the 'X1' signal turns ON.
- (2) The current position value in CW direction is read out from the buffer memory as follows:

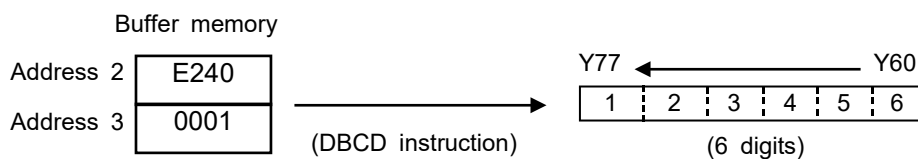

5.3.3 Program for error code readout and reset

A program example for the error code readout and error reset operation which is used when a VS-QA262B 'error detection' occurs is given below.

This program example is for Axis 1. Axis 2 programs can be generated in the same way.

Conditions

The following signal assignments are used to control VS-QA262B.

Error code (binary code) storage registerD40
Output for error code displayY70 to Y7B
Output for 'error detection' monitorY60
Output for 'sensor error detection' monitorY61
VS-QA262B 'online' commandX32
Error reset signalX50

Program example

(1) Example of program using FROM/TO instructions

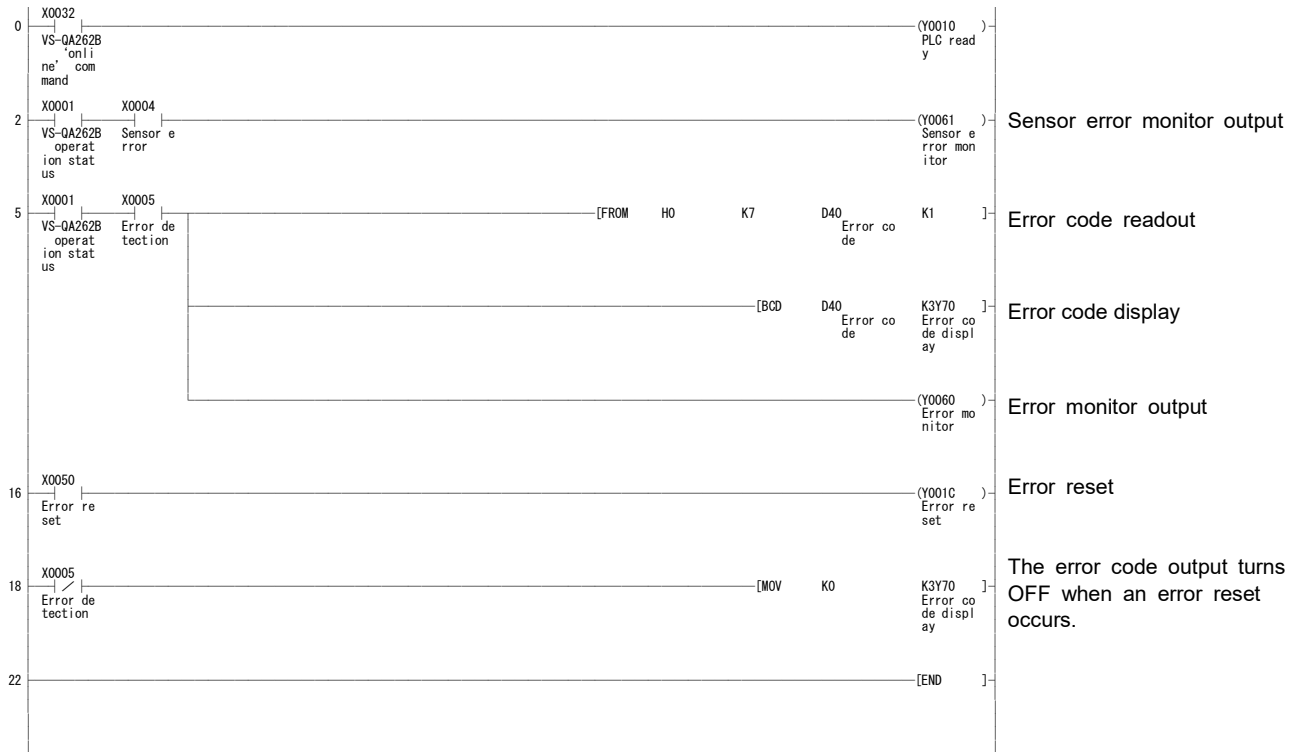

(2) Example of program using an intelligent function device (U[]¥G[]).



Explanation

- (1) The X4 signal turns ON when a sensor error occurs.
- (2) The X5 signal turns ON when an error occurs.
- (3) The error code is stored at address 7 of the buffer memory as a binary value.
- (4) VS-QA262B errors are reset when the Y1C signal is turned ON.
- (5) The error display is cleared when an error reset occurs.
- (6) The "Axis enabled/disabled" setting (Address 702 [1702]) must be set before the PLC Ready signal (Y10) is turned ON.

5.3.4 Remote I/O station programming

The master station (CPU) programming which is required when VS-QA262B is installed in a remote station is explained below.

This program example is for Axis 1. Axis 2 programs can be generated in the same way.

(1) System configuration

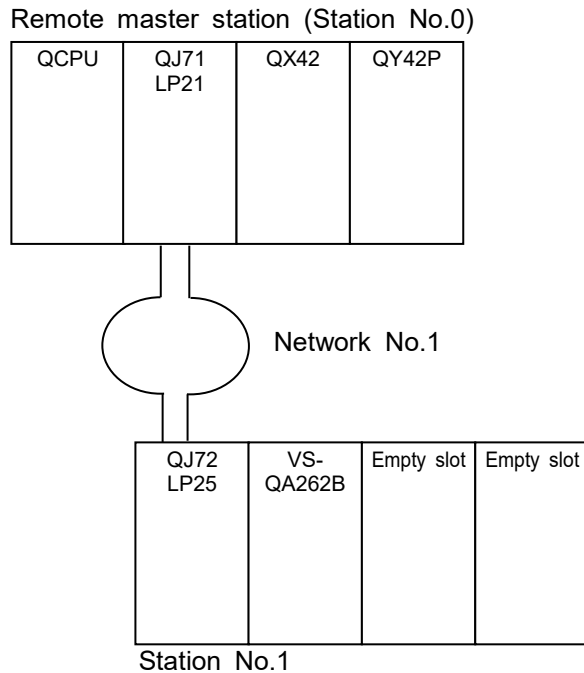

The following is an example of a program which permits a monitor display of the current position value for VS-QA262B which is installed in a remote station.

Conditions

(a) The following signal assignments are used to control VS-QA262B.

VS-QA262B 'online' command X32
 Current position value in CW direction (sensor binary) storage register D0, D1
 Current position value in CW direction (sensor binary) output to external display unit Y60 to Y77

(b) Specifies the XY setting of 'network ranges assignment' in the network parameters as shown below.

XY settings												
Station No.	Master station -> Remote station						Remote station -> Master station					
	Y			Y			X			X		
	Points	Start	End	Points	Start	End	Points	Start	End	Points	Start	End
1	32	0300	031F	32	0000	001F	32	0300	031F	32	0000	001F

(c) Specifies the 'refresh parameters' in the network parameters as shown below.

Refresh parameter settings									
	Link side					CPU side			
	Device name	Points	Start	End		Device name	Points	Start	End
Transfer 'm'	LX	32	0300	031F	↔	X	32	0300	031F
Transfer 'n'	LY	32	0300	031F	↔	Y	32	0300	031F

Note:

- This program example does not apply to basic models (Q00JCPU, Q00CPU, Q01CPU) because those models do not have a remote I/O network function.
- To read or write multiple data items at the same time, use different channel numbers for the link-dedicated instructions.

(2) Program example

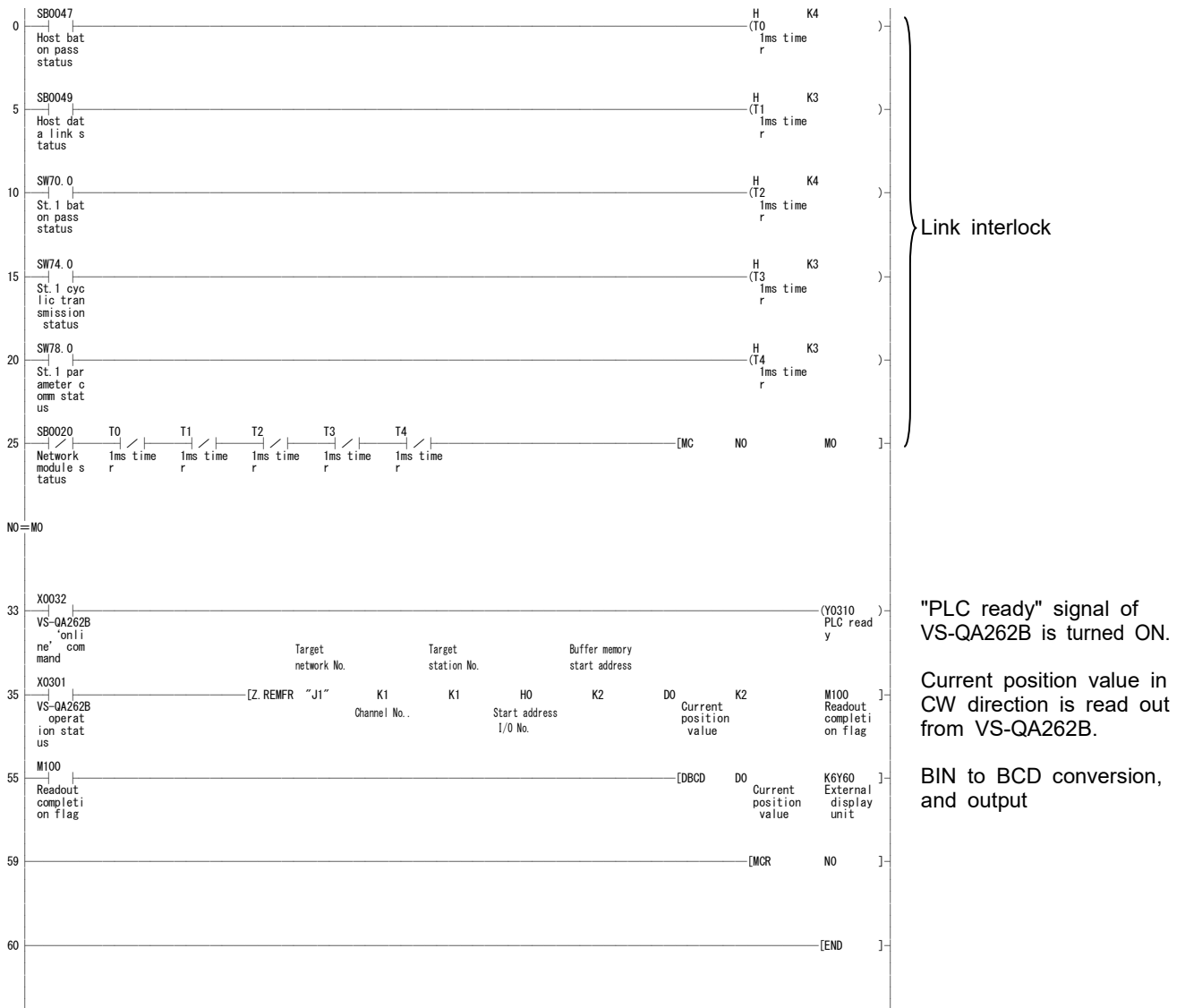

6. TROUBLESHOOTING

6. TROUBLESHOOTING

VS-QA262B operation errors and troubleshooting procedures are described in this section.

6.1 Error Code List

VS-QA262B error codes are described below.

When VS-QA262B detects an error, the corresponding error code is stored in Address 7 [1007] of the buffer memory. At that time the 'error detection' signal (X5 [X9]) is turned ON.

At the same time, the operation status display area will show the lower 5 [6] lit or blinking, with the error code (binary code) blinking.

Listed below are the possible error codes (with each hexadecimal code in parenthesis).

Error type	Lower "5 [6]" LED	Error code	Description		When detected	Countermeasure
'Buffer memory writing prohibited' errors	Blinks	10, 11 (HA, HB)	Activated when writing (using the sequence program 'TO' instruction) is attempted in a 'writing prohibited' area of buffer memory.	Sensor value (Address 0, 1 [1000, 1001])	During online status	Revise the sequence program so that writing is not attempted in a 'writing prohibited' area of the buffer memory.
		12, 13 (HC, HD)		Current position value in CW direction (Address 2, 3 [1002, 1003])		
		14, 15 (HE, HF)		Current position value in CCW direction (Address 4, 5 [1004, 1005])		
		16 (H10)		Input status (Address 6 [1006])		
		17 (H11)		Error code (Address 7 [1007])		
Detection errors	Lit on	22 (H16)	VS-QA262B detected a sensor error. Possible sensor error causes are as follows: - ABSOCODER sensor is disconnected. - ABSOCODER sensor failure - ABSOCODER cable is severed. - Malfunction at VS-QA262B's internal position detection circuit		Always	- Connect the ABSOCODER sensor. - Replace the ABSOCODER sensor. - Check the electrical condition of the ABSOCODER cable (continuity, shorts). - If the problem appears to be caused by a malfunction at the VS-QA262B internal position detection circuit, please contact your service representative.
		27 (H1B)	VS-QA262B detected a speed error. Possible speed error causes are as follows: - ABSOCODER sensor traveled faster than the speed limit. *2 - ABSOCODER sensor received severe impact. - Operation error occurred due to external noises. - Malfunction at VS-QA262B's internal position detection circuit.			- Use the ABSOCODER sensor within the speed limit. *2 - Avoid impacting the sensor. - Check that the sensor cable is away from power cable or other potential interferences. - Replace ABSOCODER or VS-QA262B. *1
Data errors	Lit on	69 (H45)	VS-QA262B detected a current position data error.		When power is turned ON.	Re-designate the current position value.
Buffer memory data writing error	Blinks	117 (H75)	Activated when incorrect data writing (using the sequence program 'TO' instruction) is attempted in a 'writing enabled' area of the buffer memory.	Current position setting value (Address 690, 691 [1690, 1691])	When current position setting command was executed.	Revise the sequence program so that writing occurs within the prescribed range.
Access error	Fast blinks	—	A PLC CPU access error has been detected.		Always	Check the PLC system.

- (1) Each time an error occurs, the previous error code stored in the buffer memory will be deleted, and replaced by the new error code.
- (2) The error status will be automatically cleared when the PLC CPU reset status is canceled.
- (3) The error code stored in the buffer memory will not be cleared (returned to '0') simply by correcting the cause of the error.

To clear the buffer memory error code, execute one of the followings:

- (a) Turn Y1C ON by the sequence program. (The pulse instruction cannot be used.)
- (b) Reset the PLC CPU.
- (c) Turn OFF the PLC power supply.

*1: If error status still continues after the suspected error cause has been removed, contact our sales representative.

*2: Error Code 27 will be detected when exceeding the following speeds:
Approx. 7 m/s: CYLNUC Cylinder (CSA,SBA,SBB,SBH), VLS-12.8
Approx. 28 m/s: IRS-51.2P

IMPORTANT	<u>Cautions to Avoid Positional Deviation Problems</u>
<p>The module may be incapable of providing a correct current position value immediately after a detection error (Error Code 22, 27) or data error (Error Code 69) has been removed. If this happens, be sure to correct the current position value using the "Current position setting" function.</p>	

6.2 Troubleshooting Flowchart

The VS-QA262B troubleshooting procedure is explained below.
For CPU module related problems, consult the manual for the CPU module in question.

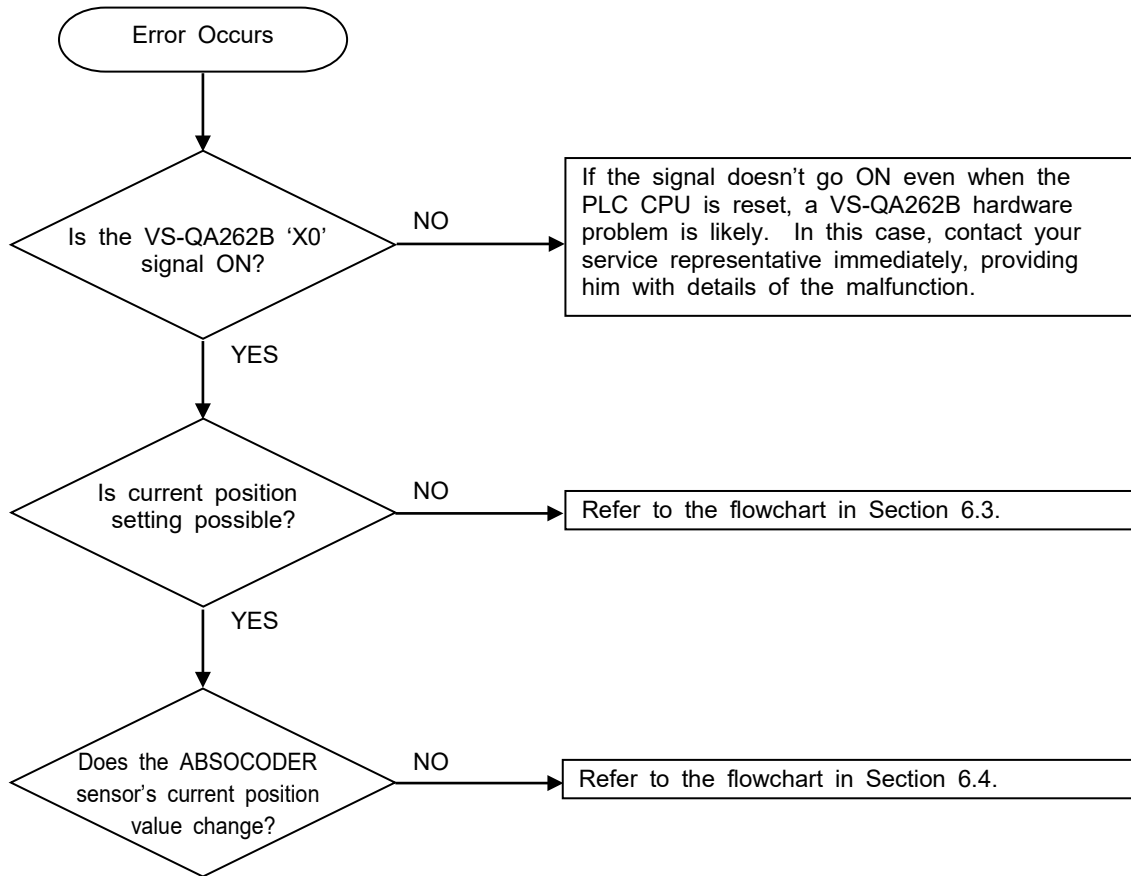

6.3 Flowchart when Current Position Setting is Impossible

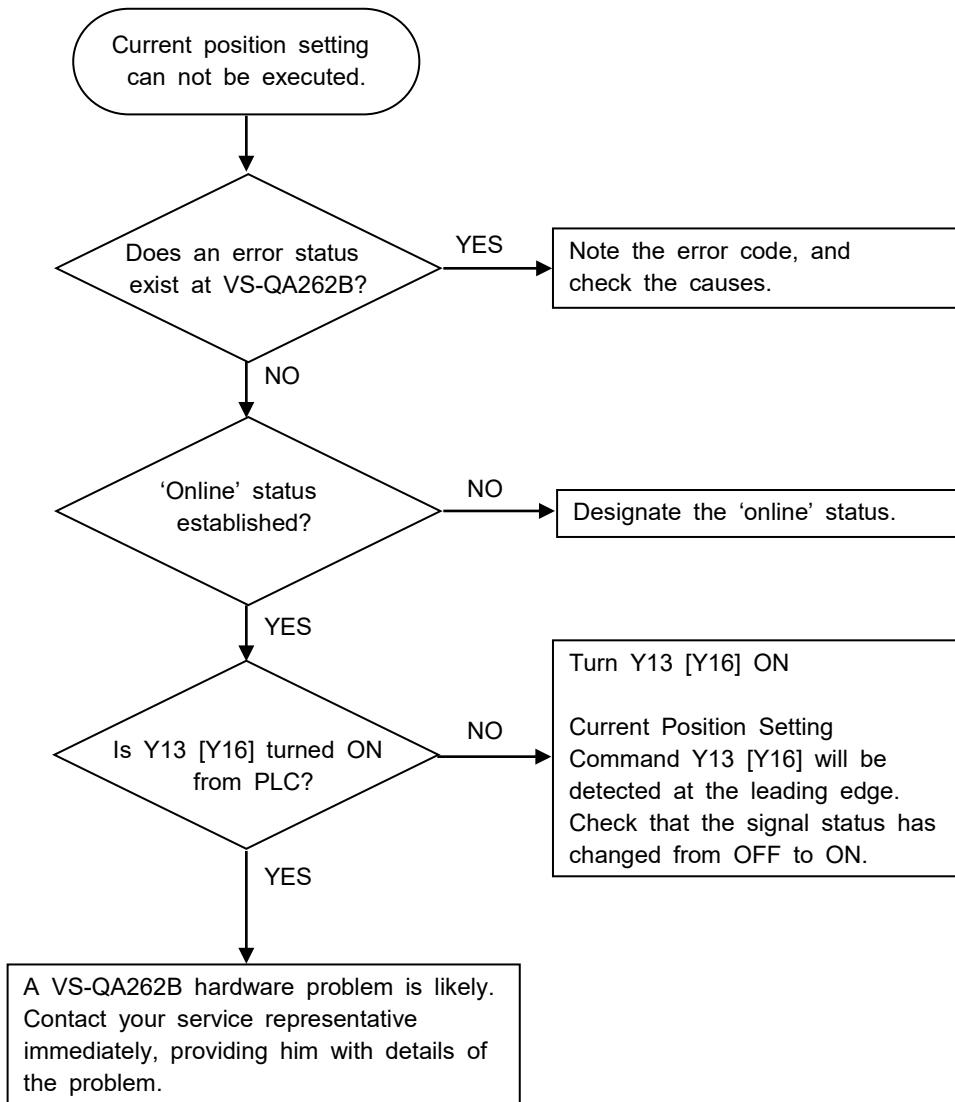

6.4 Flowchart when the ABSOCODER Sensor's Current Position Value doesn't Change

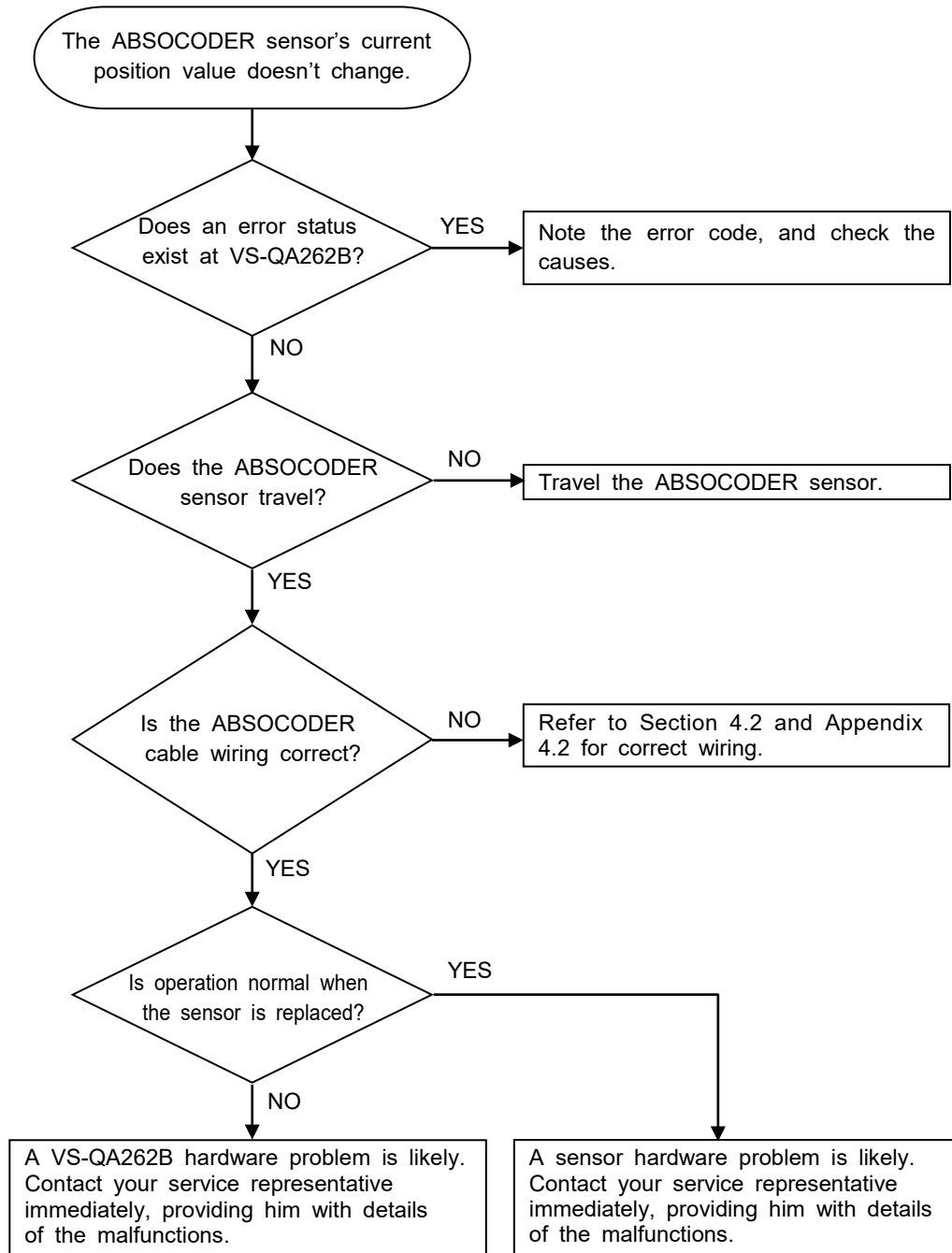

APPENDIX

APPENDIX 1 CE MARKING

VS-QA262B series conforms to EMC directive, but stands outside scope of the low voltage directive.

(1) EMC Directives

It is necessary to do CE marking in the customer's responsibility in the state of a final product. Confirm EMC compliance of the machine and the entire device by customer because EMC changes configuration of the control panel, wiring, and layout.

(2) EMC Directive and Standards

EMC Directive consists of immunity and emission items. It conforms to Table 01(see below) of EMC standards and Testing.

Table 01 EMC Standard and Testing

Class	Standard No.	Name
EMC	EN61131-2	Equipment requirements and tests of programmable controllers
EMI (Emission)	EN55011 Class A	Electromagnetic Radiation Disturbance
EMS (Immunity)	EN61000-6-2	Generic standards. Immunity standard for industrial environments
	EN61000-4-2	Electrostatic Discharge
	EN61000-4-3	Radiated, Radio frequency, Electromagnetic Field
	EN61000-4-4	Electrical Fast Transient / Burst
	EN61000-4-5	Surge Immunity
	EN61000-4-6	Conducted Disturbances, Induced by Radio-Frequency Fields
	EN61000-4-8	Power Frequency Magnetic Field

(4) Restrictions for EMC Compliance

- PLC must be installed in the control panel.
Refer to the CPU user's manual (Hardware Design / Maintenance and Inspection) for details of the install method.
- The length of I/O cable must be under 30m.
- Install the zippertubing around the cable when sensor cable is used 30m or more. The shield of zippertubing should grounded.

Recommendation zippertubing

Mounting location	Model	Manufacturer
Sensor cable	MTFS 20φ	ZIPPERTUBING(JAPAN), LTD.

[Reference]

It may be improved when clamp ferrite core is added to the extension sensor cable and I/O cable when it operates faultily by the influence from the peripheral device.

Recommendation Clamp Ferrite Core

Mounting location	Clamp ferrite core model	Manufacturer
- Extension sensor cable - I/O cable	ZCAT2032-0930 (Inner dimensions: φ9)	TDK

APPENDIX 2 UL STANDARD

The VS-QA262B Series corresponds to the UL standard.
Read this page carefully and use the VS-QA262B Series by following the described items.

(1) Installation

- Install inside the control cabinet.
- For use in pollution degree 2 environment.
- Within the surrounding air temperature 0°C to 55°C.
- Built in to Q-series PLC by Mitsubishi Electric Co.

(2) Compliance power supply

- The VS-QA262B Series shall not conform to UL and cUL standards, unless a power supply to a PLC base is made by Mitsubishi Electric Co., that is insulated and whose secondary is LVLC (Limited voltage/current circuit) defined in UL508.
- Use only a Class 2 power supply to external input/output signal lines.

(3) Wiring for external I/O

- Use field installed conductors with a temperature rating of 75°C or higher.

CAUTION

DO NOT CONNECT DIRECTLY TO LINE VOLTAGE. LINE VOLTAGE MUST BE SUPPLIED BY A SUITABLE, APPROVED ISOLATING POWER SUPPLY HAVING SHORT CIRCUIT CAPACITY NOT EXCEEDING 100 VA MAXIMUM

APPENDIX 3 KC MARK

Notification for users

사용자안내문

This product complied with the relevant Korean Safety Standard for use in the industrial environment. Thus, radio frequency interference could occur if it is used in a domestic environment.

이 기기는 업무용 환경에서 사용할 목적으로 적합성평가를 받은 기기로서 가정용 환경에서 사용하는 경우 전파간섭의 우려가 있습니다.

MEMO

APPENDIX 4 ABSOCODER SENSOR SPECIFICATIONS

Appendix 4.1 ABSOCODER Sensor for VS-QA262B-LC

Appendix 4.1.1 Specifications

Models	CYLNUC Cylinder	Rod sensor	In-rod sensor
	CSA·SBA·SBB·SBH	VLS-12.8	IRS-51.2P
Absolute detection range	12.8mm (0.5039inch)		51.2mm (2.0157inch)
Resolution	1.5625 μ m (12.8mm/8192)		6.25 μ m (51.2mm/8192)

For more details of the ABSOCODER sensor, contact your NSD representative.

Appendix 4.1.2 ABSOCODER Sensor Dimensions

Contact your NSD representative for ABSOCODER sensor dimension.

Appendix 4.2 ABSOCODER Cable

Appendix 4.2.1 Specifications

Items		Specifications	
Model code		3P-S	3P-RBT
Cable type		Standard cable	Robotic cable
Diameter		ϕ 8	
Ambient temperature	Operating	-5 to +60°C	
	Storage	-5 to +60°C	-10 to +60°C
Insulator		Irradiated cross linked foamed polyethylene	ETFE plastic
Sheath		Vinyl chloride mixture	
Construction		6-core, 2 pairs without shield + 1 pair with shield	
Color		Gray	Black
Advantage		Extendable for long distances	Superior flexibility; ideal for moving place

Appendix 4.2.2 Cable length restrictions

There is a limitation in extendable length of the ABSOCODER cable.

Cable model	3P-S	3P-RBT
Maximum sensor cable length	100m	50m

REMARKS

Contact your NSD representative when the ABSOCODER cable combines different types of cables.

Appendix 4.2.3 ABSOCODER Cable Dimensions

(1) 3P-S-0102-[L] / 3P-RBT-0102-[L]

Units: mm

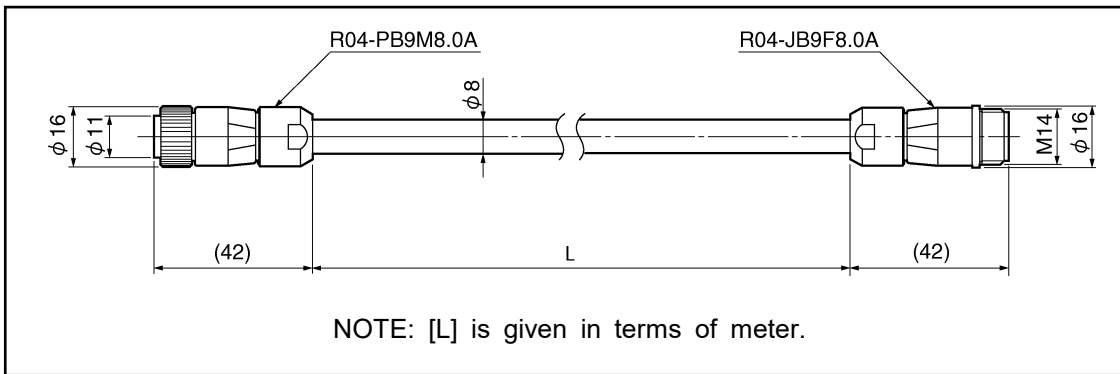



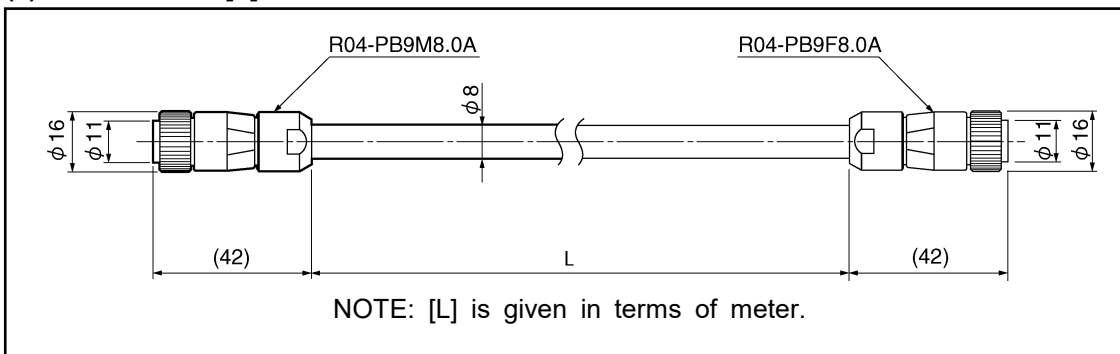

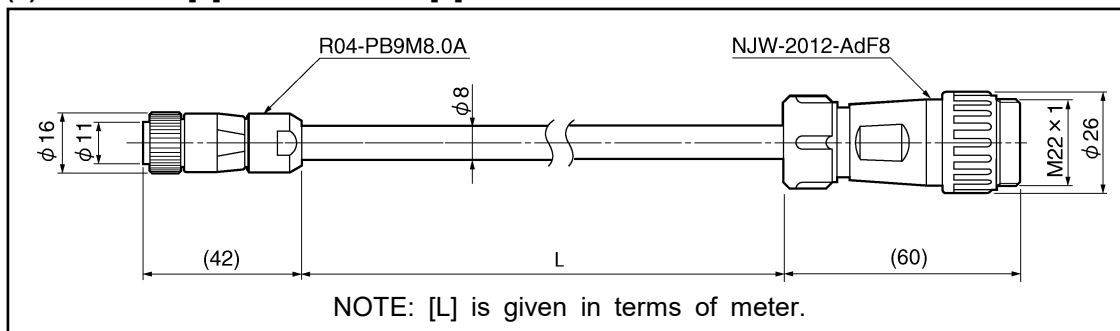

(2) 3P-RBT-0103-[L]

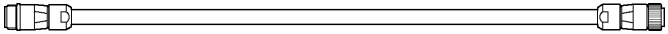

(3) 3P-S-0144-[L] / 3P-RBT-0144-[L]

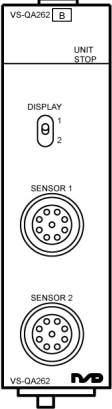
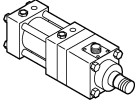
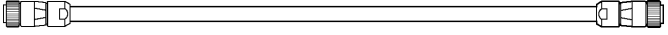

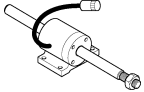
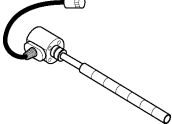
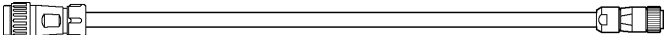
Appendix 4.2.4 ABSOCODER Cable Connection

ABSOCODER sensor	Extension sensor cable	VS-QA262B
<p>CSA</p> 	<p>3P-S(RBT)-0102</p>  <p>3P-S(RBT)-0102 3P-S(RBT)-0102</p> 	
<p>SBA · SBB · SBH</p> 	<p>3P-RBT-0103</p>  <p>3P-RBT-0103 3P-S(RBT)-0102</p> 	
<p>VLS-12.8</p>  <p>IRS-51.2P</p> 	<p>3P-S(RBT)-0144</p>  <p>3P-S(RBT)-0144 3P-S(RBT)-0102</p> 	

APPENDIX 5 DIMENSIONS

Appendix 5.1 VS-QA262B Position Detection Module

Units: mm

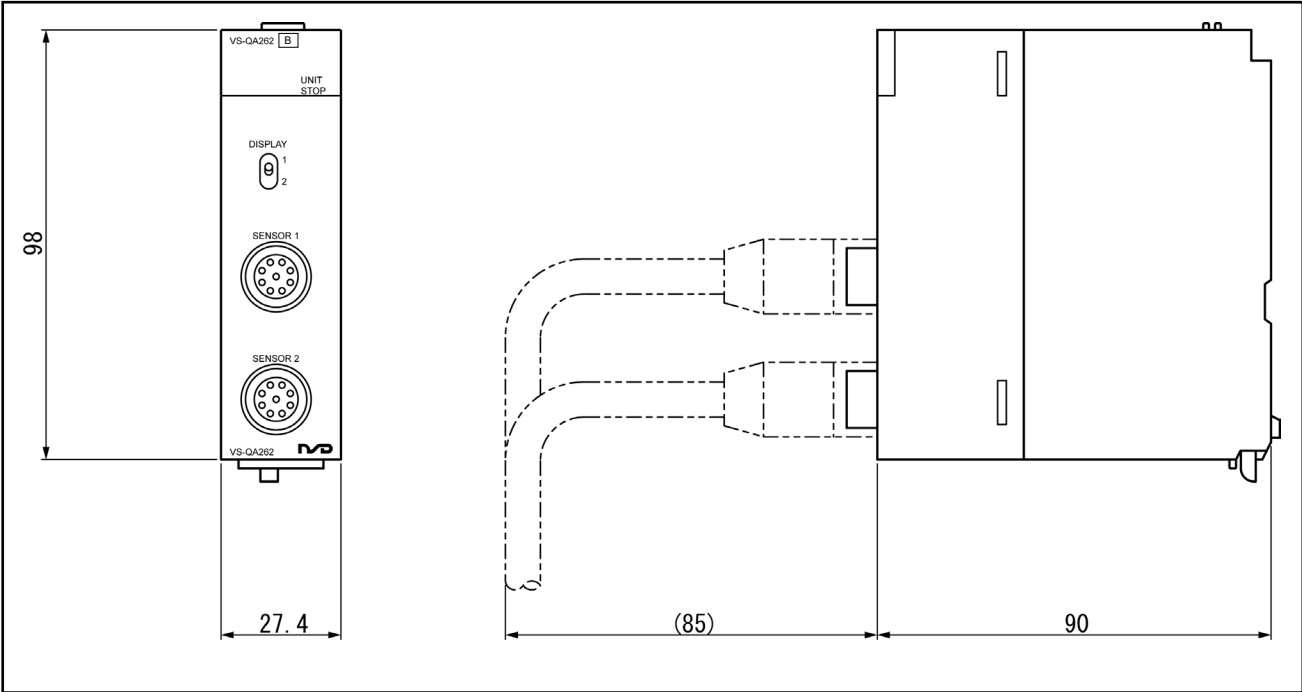

APPENDIX 6 ABSOCODER SENSOR CHECK LIST

● **Applicable ABSOCODER sensor models**
CSA, SBA, SBB, SBH

Contact our sales representative for VLS-12.8 and IRS-51.2.

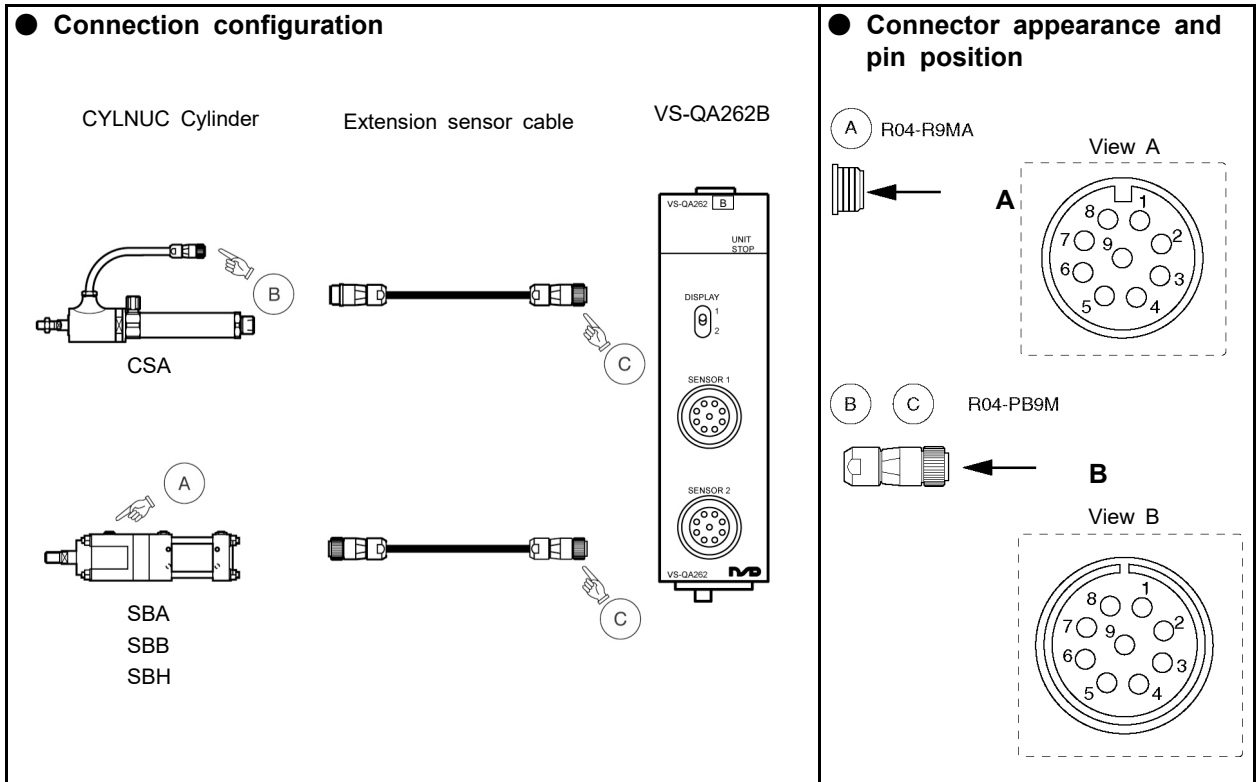

Checks at Point C should be carried out with Point A (or Point B) connected.

● **Connector pin position and standard coil resistance ranges (at 25°C)**

Connector pin No.	Signal name	Wiring color	Standard coil resistance [Ω]						
			CSA		SBA / SBB / SBH				
			φ 20	φ 40	φ 40	φ 50	φ 63	φ 80	φ 100
1	SIN+	Brown	61 to 136	71 to 146	20 to 60	23 to 63	25 to 65	30 to 70	42 to 82
2	SIN-	Red							
3	-COS+	Orange	61 to 136	71 to 146	20 to 60	23 to 63	25 to 65	30 to 70	42 to 82
4	-COS-	Yellow							
5	OUT1+	Green	185 to 215	203 to 233	57 to 77	61 to 81	67 to 87	81 to 101	100 to 128
6	OUT1-	Blue							
7	—	—	—	—	—	—	—	—	—
8	—	—	—	—	—	—	—	—	—
9	Shield	Shield	—	—	—	—	—	—	—
—	—	—	—	—	—	—	—	—	—

The above standard coil resistance ranges are referential data to assist wiring disconnection diagnosis and are not product specification values. There may be no wiring disconnection even when the resistance measurement is out of the standard resistance range.

● **Circuit resistance check**

[Measurement method]

Measure resistance at Point A, B, or C using a circuit tester or other appropriate device. If the connector is off, identify the line by the wiring color.

[Check details]

Refer to the previous page for the connector pin number.

Check position	Criterion	Check position	Criterion
Between brown and red	The measured value should be in the range of the standard coil resistance. *1	Between brown and orange, green, shield	∞
Between orange and yellow		Between orange and green, shield	
Between green and blue		Between green and shield	
		Between frame and each wire	

*1: If checks are done at Point C, the measurement value is [Standard coil resistance + extension sensor cable resistance (cable length (m) x 0.2 (Ω))].
 The resistance value of the NSD special cable is 0.2Ω/m (loop resistance).
 Consider resistance variations due to temperature, which, relative to the standard temperature (25°C), increases 0.4% when the temperature rises 1°C and decreases 0.4% when the temperature falls 1°C.

● **Insulation check**

[Measurement method]

Measure using a 500 VDC insulation tester.

[Check details]

Refer to the previous page for the connector pin number.

Check position	Criterion
Between brown and orange, green, shield	10MΩ or more
Between orange and green, shield	
Between green and shield	
Between frame and each wire	

	NOTES
<ol style="list-style-type: none"> 1. Make sure to disconnect the ABSOCODER sensor from VS-QA262B before carrying out insulation checks. 2. If there is a risk that energization may cause damages to the electronic circuits in and around the machine, remove the ABSOCODER sensor from the machine. 3. After completing the checks, short-circuit between the pins to discharge remaining voltage before connecting the ABSOCODER sensor to VS-QA262B. 	

APPENDIX 7 I/O SIGNALS and BUFFER MEMORY FUNCTION LIST

○: enabled
×: disabled

Signal type	VS-QA262B (online/offline)		Online	Offline	Remarks	
	Device No., address, and name					
Signal inputs to PLC CPU	X0	Unit ready (VS-QA262B detection item)	○	○		
	X1	VS-QA262B operation status (online/offline)	ON	OFF		
	X4	Axis 1	Sensor error detection	○	○	
	X5		Error detection	○	○	
	X8	Axis 2	Sensor error detection	○	○	
	X9		Error detection	○	○	
Signal outputs from PLC CPU	Y10	PLC ready	ON	OFF		
	Y13	Axis 1	Current position setting command	○	×	Detected at leading edge
	Y16	Axis 2	Current position setting command	○	×	Detected at leading edge
	Y1C	Error reset		○	○	Detected at leading edge
Buffer memory	0, 1	Axis 1	Sensor value (Raw sensor binary value)	○	×	
	2, 3		Current position value in CW direction (sensor binary)	○	×	
	4, 5		Current position value in CCW direction (sensor binary)	○	×	
	6		Input status	○	○	
	7		Error code	○	○	
	690, 691		Current position setting value	○	○	
	694		Current position setting "disabled"	○	○	
	702		Axis enabled/disabled	○	○	
	1000, 1001	Axis 2	Sensor value (Raw sensor binary value)	○	×	
	1002, 1003		Current position value in CW direction (sensor binary)	○	×	
	1004, 1005		Current position value in CCW direction (sensor binary)	○	×	
	1006		Input status	○	○	
	1007		Error code	○	○	
	1690, 1691		Current position setting value	○	○	
1694	Current position setting "disabled"		○	○		
1702	Axis enabled/disabled		○	○		



NSD Group

Manufacturer

NSD Corporation 3-31-28, OSU, NAKA-KU, NAGOYA, JAPAN 460-8302

Distributor

NSD Trading Corporation 3-31-23, OSU, NAKA-KU, NAGOYA, JAPAN 460-8302

Phone: +81-52-261-2352 Facsimile: +81-52-252-0522

URL: www.nsdcorp.com E-mail: foreign@nsdcorp.com

Copyright©2023 NSD Corporation All rights reserved.