



For Iron and Steel Industry



**ABSOCODER Converter
For PROFIBUS-DP**

NCW-3DHPRM2R

Specifications & Instruction Manual

Applicable sensor: MRE-32SP061

MRE-G[]SP061

MRE-32SP074

MRE-G[]SP074

MRE-32SP097

MRE-G[]SP097

MRE-32SP101

MRE-G[]SP101



GENERAL SAFETY RULES



(Please read this safety guide carefully before operation)

Thank you very much for purchasing our product. Before operating this product, be sure to carefully read this manual so that you may fully understand the product, safety instructions and precautions.

- Please submit this manual to the operators actually involved in operation.
- Please keep this manual in a handy place.



Signal Words

Safety precautions in this guide are classified into DANGER and CAUTION.

Symbol	Meaning
 DANGER	Incorrect handling may cause a hazardous situation that will result in death or serious injury.
 CAUTION	Incorrect handling may cause a hazardous situation that will result in moderate injury or physical damage.

Instructions accompanied by a symbol  may also result in serious damage or injury. Be sure to follow the all instructions accompanied by the symbol.

Graphic Symbols







Symbol	Meaning
	Indicates prohibited items.
	Indicates items that must be performed to.



Application Limitation

This product is not designed to be used under any situation affecting human life. When you are considering to use this product for special purposes such as medical equipment, aerospace equipment, nuclear power control systems, traffic systems, and etc., please consult with NSD.



This product is designed to be used under the industrial environments categorized in Class A device. The supplier and user may be required to take appropriate measures.

1. Handling Precautions



 DANGER	
	- Do not touch components inside of the controller; otherwise, it will cause electric shock.
	- Do not damage the cable by applying excessive load, placing heavy objects on it, or clamping; otherwise, it will cause electric shock or fire.
	- Turn the power supply OFF before wiring, transporting, and inspecting the controller; otherwise, it may cause electric shock.
	- Provide an external safety circuit so that the entire system functions safely even when the controller is faulty.
	- Connect the grounding terminal of the controller; otherwise, it may cause electric shock or malfunction.

 CAUTION	
	- Do not use the controller in the following places; water splashes, the atmosphere of the corrosion, the atmosphere of the flammable vapor, and the side of the combustibility. Doing so may result in fire or the controller may become faulty.
	- Be sure to use the controller and the ABSOCODER sensor in the environment designated by the general specifications in the manual. Failure to do so may result in electric shock, fire, malfunction or unit failure. - Be sure to use the specified combination of the ABSOCODER sensor, controller and sensor cable; otherwise, it may cause fire or controller malfunction.



2. Storage

 CAUTION	
	- Do not store the controller in a place exposed to water, or toxic gas and liquid.
	- Be sure to store the controller in designed temperature and humidity range, and do not exposed to direct sunlight. - Be sure to consult with NSD when the controller is stored for long periods.



3. Transport



 CAUTION	
	- Do not hold the cable or shaft of ABSOCODER sensor during transport; otherwise, it will cause injury or controller malfunction.

4. Installation



 CAUTION	
	- Do not step on the ABSOCODER sensor or place heavy objects on the controller; otherwise, it will cause injury. - Do not block the exhaust port or allow any foreign matter to enter the controller; otherwise, it will cause fire or unit failure.
	- Be sure to secure the controller and ABSOCODER sensor with the provided brackets; otherwise, it may cause malfunction, injury, or drop. - Be sure to secure the specified distance between the main body and the control panel or other equipments; otherwise, it may cause malfunction.

5. Wiring



 DANGER	
	- Be sure to secure the terminal block firmly; otherwise, it may have risk of fire. - Be sure to mount the terminal cover provided with the controller, before supplying the power, starting operation after the installation, and wiring; otherwise, it may cause electric shock.

 CAUTION	
	- Be sure to keep the sensor cable, control cable, and communication cable at least 300 mm away from the main circuit and power line; otherwise it may cause injury or malfunction. - Be sure to connect all cables correctly; otherwise, it may cause injury or controller malfunction. - Be sure to firmly connect the external I/O connectors and sensor connectors; otherwise, it may cause incorrect inputs and outputs or injury.



6. Operation

 CAUTION	
	- Do not change the controller's function switch settings during the operation; otherwise, it will cause injury. - Do not approach the machine after instantaneous power failure has been recovered. Doing so may result in injury if the machine starts abruptly, it will cause injury.
	- Be sure to check that the power supply specifications are correct; otherwise, it may caused controller failure. - Be sure to provide an external emergency stop circuit so that operation can be stopped with power supply terminated immediately. - Be sure to conduct independent trial runs for the controller before mounting the controller to the machine; otherwise, it may cause injury. - When an error occur, be sure to eliminate the cause, ensure safety, and reset the error before restarting operation; otherwise, it may cause injury.

7. Maintenance And Inspection

 CAUTION	
	- Do not disassemble, remodel, or repair the unit; otherwise, it will cause electric shock, fire, and unit malfunction.
	- The capacitor of the power line deteriorates through prolonged use. We recommended that the capacitor be replaced every five years to prevent secondary damage.

8. Disposal

 CAUTION	
	- Be sure to handle the controller as industrial waste while disposing of it.

- MEMO -

CONTENTS

1. OVERVIEW	1
1-1. Features	1
2. MODEL SELECTION WHEN ORDERING	2
3. SPECIFICATIONS	4
3-1. Converter Specifications	4
3-2. ABSOCODER Sensor Specifications.....	6
3-3. Extension Sensor Cable Specification	9
4. DIMENSIONS	10
4-1. Converter Dimension	10
4-2. ABSOCODER Sensor Dimensions	11
4-3. Extension Sensor Cable Dimensions	15
5. CHECKING THE CONTENTS OF THE SHIPPING CASE	16
6. INSTALLATION	17
6-1. Converter Installation Conditions and Precautions.....	17
6-2. ABSOCODER Sensor Installation Conditions and Precautions	18
7. WIRING	21
7-1. Connection between Converter and ABSOCODER Sensor.....	21
7-1-1. Connection configure example of the sensor cable	22
7-2. Power Supply Connection.....	25
8. NOMENCLATURE	26
8-1. Part Identification	26
8-2. Function and Name of Display and Setting Area	27
8-2-1. Display contents of the monitor LEDs	27
8-2-2. Error clear button (CLR).....	29
8-2-3. Zero setting button (ZPS1, ZPS2).....	29
8-2-4. Node address setting switch (NODE)	29
9. PROFIBUS-DP Communication	30
9-1. Position Data (Input Data: Slave → Master)	30
9-2. Preset Data (Output Data: Master → Slave).....	31
9-3. Alarm Data (Extended Diagnostic Data)	36
9-4. Parameter Data.....	41
10. INSPECTION	43
11. Troubleshooting	44
11-1. Troubleshooting Flowchart	44
11-1-1. Flowchart when Position Data doesn't Change	45
11-1-2. Flowchart when Position Data is not Read.	46
11-2. ABSOCODER Sensor Check List	48
12. CE MARKING	50
12-1. EMC Directives	50
12-2. EMC Directive and Standards	50
12-3. Low Voltage Directive	50
12-4. Measures for EMC Compliance	51
12-5. Restrictions	51

1. OVERVIEW

NCW-3DHPRM2R converter (hereafter called NCW-3DHPR) can be combined with a multi-turn type of ABSOCODER sensor (MRE) to detect the machine position.

This converter communicates with programmable logic controllers by PROFIBUS-DP.

● GSD file

This product requires a definition file (GSD file) which is installed to the configuration tool.

Download GSD file from the following URL.

URL: www.nsdcorp.com

1-1. Features

(1) High reliability

An absolute position detection format ensures accurate position detection even if a power interruption or unexpected noise condition occurs. An origin returning operation is not required.

(2) Superior durability

ABSOCODER sensor is not used electronic parts except coils and resistance, and it features a no-contact construction excepting bearing. This sensor offers problem-free operation, even in environment where it is exposed to vibration, impact shocks, extreme temperatures, oil, and dust.

(3) Compact design

The unit's outside dimensions (39(W) x 155(H) x 93(D)) were miniaturized. DIN rail can be used, so mounting is much easier.

(4) PROFIBUS-DP communication

PROFIBUS-DP communication enables easy transmission of Position data, Preset data, Alarm data, and Parameter data.

- 8-byte output data and 8-byte input data communication.
- Baud rate of 9.6kbs ~ 12Mbps.
- Node address can be set by the node address setting switch on the converter's front panel.

(5) Two axes ABSOCODER sensor can connect

The machine positions for two axes can be detected by one converter. The space-saving in the control panel can be conducted.

(6) Diagnosis function

The error information can be expressed both by PROFIBUS-DP alarm data and by monitor LEDs on the converter's front panel.

(7) Preset function

The position data can be preset to the desired value from the PROFIBUS-DP master.

Moreover the position data can also be changed to "0" by pressing the [ZPS] switch on the converter's front panel.

(8) Configuration tool

Parameter data settings can be changed by using the PROFIBUS-DP configuration tool (PROFIBUS configuration software).

(9) Applicable with JKPEV-S cable

A commercially available cable (JKPEV-S 1.25mm² x 5P) can be used between the converter and ABSOCODER sensor.

(10) Compliance with CE standards

The converter complies with CE (EMC Directive) standards.

2. MODEL SELECTION WHEN ORDERING

The following figure indicates the connection configuration of NCW-3DHPR.

Before ordering, refer to the connection configuration and model list. Please prepare by customer except (1) to (4) in the connection configuration.

● Connection configuration

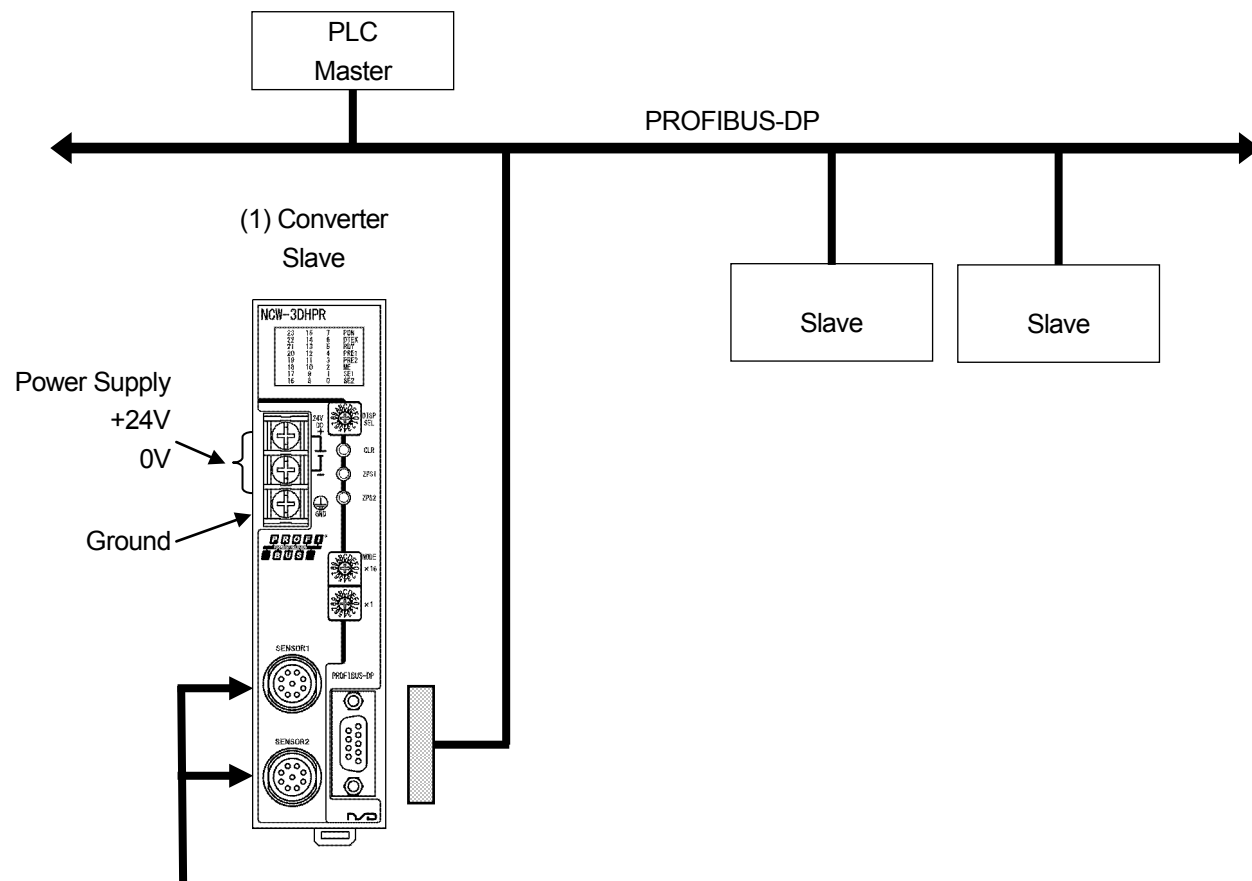



(3) Extension sensor cable	(2) ABSOCODER sensor		(4) Option
<p>In the case of using the NSD special cable</p>	<p>Connector type</p> <p>B</p>	<p>MRE-[]SP061 MRE-[]SP074 MRE-[]SP097 MRE-[]SP101</p>	<p>RB-01 L type flange for MRE-[]SP061</p>
<p>In the case of using the commercially available cable</p>	<p>P</p> <p>R</p>		

● Model List

◆ Converter

No.	Model	Description
(1)	NCW-3DHPRM2R	For multi-turn type ABSOCODER sensor Position data 17bit binary code output

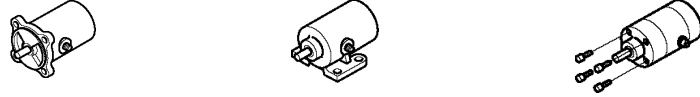
◆ ABSOCODER sensor

No.	Model	Description
	MRE-[1]SP061FK[3]	General environment type Flange-mount type With Interconnecting cable 2m
	MRE-[1]SP074[2] K [3][L]-G	Compact size heavy duty type, SUS
	MRE-[1]SP097[2] K [3][L]-G	Heavy duty type, cast iron
	MRE-[1]SP101[2] K [3][L]-G	Heavy duty type, SUS
(2)	<p>[2]: Mounting format F: Flange-mount type L: Base-mount type M: Face-mount type (Only available for MRE-SP074)</p>  <p>K: Input shaft (sunk key)</p>  <p>[3]: Connector type B: Standard connector for the NSD special cable (NJV-2012-PM8, manufacturer: Nanaboshi Electric Mfg.Co.Ltd.) P: Large connector for JKPEV-S cable (NWPC-4012-Ad12, manufacturer: Nanaboshi Electric Mfg.Co.Ltd.) R: Crimping terminals for JKPEV-S cable and the NSD special cable (R1.25-4)</p> <p>[L]: Interconnecting sensor cable length (m): 2, 5, 10, 20</p> <p>G: Silicon oil injected, no code: no oil injected</p>	

◆ Extension sensor cable

No.	Model	Description
(3)	4P-S-0144-[L]	Standard cable
	4P-RBT-0144-[L]	Robotic cable
	4P-URT-0144-[L]	Semi-heat-resistant robotic cable
	4P-S-4344-[L]	Standard cable
	4P-RBT-4344-[L]	Robotic cable
	4P-URT-4344-[L]	Semi-heat-resistant robotic cable
	4P-HRT-4344-[L]	Heat-resistant robotic cable
	4P-S-0155-[L]	Standard cable
	4P-RBT-0155-[L]	Robotic cable
	4P-URT-0155-[L]	Semi-heat-resistant robotic cable
	4P-S-0190-[L]	Standard cable
	4P-RBT-0190-[L]	Robotic cable
	4P-URT-0190-[L]	Semi-heat-resistant robotic cable
	JKPEV-S(1.25mm ² ×5P)	Commercially available cable

[L]: Specify the cable length (m) that you need.

◆ Option

No.	Model	Description
(4)	RB-01	L-type flange for MRE-32SP061, MRE-G[]SP061

3. SPECIFICATIONS

3-1. Converter Specifications

(1) General specification

Items	Specifications
Power supply voltage	24VDC±10% (including ripple)
Power consumption	10W or less
Insulation resistance	20 M-Ohms or more between external DC power terminals and ground (by 500 VDC insulation resistance tester)
Withstand voltage	500 VAC, 60Hz for 1 minute between external DC power terminals and ground
Vibration resistance	20m/s ² 10 to 500Hz, 10cycles of 5 minutes in 3 directions, conforms to JIS C 0040 standard
Ambient operating temperature	0 to +55°C (No freezing)
Ambient operating humidity	20 to 90 %RH (No condensation)
Ambient operating environment	Free from corrosive gases and excessive dust
Ambient storage temperature	-25 to +70°C
Grounding	Must be securely grounded (ground resistance of 100 ohm or less)
Construction	Book-shelf type within enclosure, DIN rail mountable
Outside dimension (mm)	39(W) x 155(H) x 93(D) Refer to dimensions for details.
Mass	Approx. 0.4kg

(2) Performance specification

Items	Specifications	Notes
Applicable sensor	MRE-[]SP061 MRE-[]SP074 MRE-[]SP097 MRE-[]SP101	
Total number of divisions	131072(2 ¹⁷)	
Number of effective bits	17 (D0 to D16)	
Position detection format	Absolute format	
Output code	Binary code	
Number of detection axes	2	
Position data sampling time	0.2ms	
Error detection	- PROFIBUS-DP power supply error - Sensor error - Memory error - Watchdog timer error	
Auxiliary functions	Preset function	
Monitor LED	PON: Power ON	LED display changes by selecting the DISP. SEL switch.
	DTEX: PROFIBUS-DP data refresh in progress	
	RDY: Converter normal (ready for operation)	
	PRE1/PRE2: Preset operation (zero set)	
	ME: Memory error	
	SE1/SE2: Sensor error	
	Position data: D0-D23	
	Preset data: D0-D23	
Front panel operation	Converter's diagnosis data	
	Parameter data	
	Error clear: CLR	
	Zero set: ZPS1/ZPS2	
Applicable standard	LED display selecting: DISP SEL	
	PROFIBUS-DP node address setting: NODE x16, x1	
	CE Marking (EMC directive)	

(3) PROFIBUS-DP specification

Items	Specifications
Interface	PROFIBUS-DP (V0)
Baud rates	9.6k, 19.2k, 45.45k, 93.75k, 187.5k, 500k, 1.5M, 3M, 6M, 12M [Baud] (Automatic Baud Rate Identification)
Supported Global Control	Freeze, Sync
Set_Slave_Address	not supported
Station type	modular device
Max_Module	1
Max_input_length	8 [bytes]
Max_output_length	8 [bytes]
Extended diagnostic information	8 [bytes]
Ext_Module_Prm_Data_Length	7 [bytes]
Others	Refer to the GSD file for details

3-2. ABSOCODER Sensor Specifications

(1) MRE-[]SP061

Items		Specifications				
Sensor model	MRE-32SP061	MRE-[]SP061				
		[]: Total number of turns, and with a gear(G) or without gear				
		[G64]	[G128]	[G160]	[G256]	[G320]
Total number of turns	32	64	128	160	256	320
Divisions / turn	4096	2048	1024	819.2	512	409.6
Total number of divisions	131072 (2 ¹⁷)					
Mass	1.5kg	1kg				
Linearity error	0.7° Max.	1.4° Max.	2.8° Max.	3.5° Max.	5.6° Max.	7.0° Max.
Moment of inertia GD ² /4(J)	6.7 x 10 ⁻⁶ kg·m ² (6.8 x 10 ⁻⁵ kgf·cm·s ²)	3.9 x 10 ⁻⁶ kg·m ² (4 x 10 ⁻⁵ kgf·cm·s ²)				
Starting torque	4.9 x 10 ⁻² N·m or less (0.5 kgf·cm or less)					
Permissible shaft load	Radial	98N (10 kgf)				
	Thrust	49N (5 kgf)				
Permissible mechanical speed	2000r/min	3600r/min				
Bearing life	4.5 x 10 ⁴ h (at 2000r/min)	1.5 x 10 ⁴ h (at 3600 r/min)				
Ambient temperature	Operating	-20 to +80°C				
	Storage	-30 to +90°C				
Vibration resistance	2.0 x 10 ² m/s ² (20G)	98m/s ² (10G)				
	200Hz, up/down 4 h, forward/back 2 h, conforms to JIS D 1601 standard					
Shock resistance	4.9 x 10 ³ m/s ² (500G)	2.9 x 10 ³ m/s ² (300G)				
	0.5 ms, up/down/forward/back x 3 times each, conforms to JIS C 5026 standard					
Protection rating	IP65, conforms to JEM 1030 standard					
Interconnecting cable	2m					
Max. sensor cable length	4P-S	200m	300m			
	4P-RBT/URT /HRT	100m	150m			
	JKPEV-S (1.25mm ² x 5P)	200m	300m			
Surface treatment	Case: electroless nickel plated Cap: anodic oxide coated	Anodic oxide coated				
Material	Case: steel Cap: aluminum	Aluminum				

(2) MRE-[]SP074

Items	Specifications					
Sensor model	MRE-[]SP074					
	[]: Total number of turns, and with a gear(G) or without gear					
	[32]	[G64]	[G128]	[G160]	[G256]	[G320]
Total number of turns	32	64	128	160	256	320
Divisions / turn	4096	2048	1024	819.2	512	409.6
Total number of divisions	131072 (2 ¹⁷)					
Mass	Flange-mount type: 3.5+0.1 x cable length (m) kg Base-mount type: 5.5+0.1 x cable length (m) kg Face-mount type: 3.0+0.1 x cable length (m) kg					
Linearity error	0.6° Max.	1.2° Max.	2.4° Max.	3.0° Max.	4.8° Max.	6.0° Max.
Moment of inertia GD ² /4(J)	3.3 x 10 ⁻⁵ kg·m ² (3.4 x 10 ⁻⁴ kgf·cm·s ²)					
Starting torque	9.8 x 10 ⁻² N·m or less (1 kgf·cm or less)					
Permissible shaft load	Radial	98N (10kgf)				
	Thrust	49N (5kgf)				
Permissible mechanical speed	4000r/min					
Bearing life	8 x 10 ⁴ h (at 4000r/min)					
Ambient temperature	Operating	-20 to +120°C				
	Storage	-30 to +120°C				
Vibration resistance	2.0 x 10 ² m/s ² (20G) 200Hz, up/down 4 h, forward/back 2 h, conforms to JIS D 1601 standard					
Shock resistance	4.9 x 10 ³ m/s ² (500G) 0.5 ms, up/down/forward/back x 3 times each, conforms to JIS C 5026 standard					
Protection rating	IP67, conforms to JEM 1030 standard					
Interconnecting cable	2 · 5 · 10 · 20m					
Max. sensor cable length	4P-S	300m				
	4P-RBT/URT /HRT	150m				
	JKPEV-S (1.25mm ² x 5P)	300m				
Surface treatment	Not treated					
Material	Stainless					

(3) MRE-[]SP097 / MRE-[]SP101

Items		Specifications										
Sensor model		MRE-[]SP097 / MRE-[]SP101										
		[]: Total number of turns, and with a gear (G) or without gear										
		[32]	[G64]	[G128]	[G160]	[G256]	[G320]	[G512]	[G1280]	[G2048]	*1 [G2560]	*1 [G3072]
Total number of turns		32	64	128	160	256	320	512	1280	2048	2560	3072
Divisions / turn		4096	2048	1024	819.2	512	409.6	256	102.4	64	51.2	42.6
Total number of divisions		131072 (2 ¹⁷)										
Mass		7+0.1 x cable length (m) kg										
Linearity error		0.6° Max.	1.2° Max.	2.4° Max.	3.0° Max.	4.8° Max.	6.0° Max.	9.6° Max.	24° Max.	38.4° Max.	48° Max.	56° Max.
Moment of inertia GD ² /4(J)		3.3 x 10 ⁻⁵ kg·m ² (3.4 x 10 ⁻⁴ kgf·cm·s ²)										
Starting torque		9.8 x 10 ⁻² N·m or less (1 kgf·cm or less)										
Permissible shaft load	Radial	1.5 x 10 ² N (15kgf)										
	Thrust	78N (8kgf)										
Permissible mechanical speed		4000r/min										
Bearing life		8 x 10 ⁴ h (at 4000r/min)										
Ambient temperature	Operating	-20 to +120°C										
	Storage	-30 to +120°C										
Vibration resistance		2.0 x 10 ² m/s ² (20G) 200Hz, up/down 4 h, forward/back 2 h, conforms to JIS D 1601 standard										
Shock resistance		4.9 x 10 ³ m/s ² (500G) 0.5 ms, up/down/forward/back x 3 times each, conforms to JIS C 5026 standard										
Protection rating		IP67, conforms to JEM 1030 standard										
Interconnecting cable		2 · 5 · 10 · 20m										
Max. sensor cable length	4P-S	300m										
	4P-RBT/URT /HRT	150m										
	JKPEV-S (1.25mm ² × 5P)	300m										
Surface treatment		MRE-[]SP097: coated (epoxy resin) MRE-[]SP101: not treated										
Material		MRE-[]SP097: Cast iron MRE-[]SP101: stainless										

*1: MRE-G2560SP097 and MRE-G3072SP097 cannot be selected.

3-3. Extension Sensor Cable Specification

Items	Specifications			
Model code	4P-S	4P-RBT	4P-URT	4P-HRT
Cable type	Standard cable	Robotic cable	Semi heat-resistant robotic cable	Heat-resistant robotic cable
Diameter	$\phi 8$			
Operating temperature range	-5 to +60°C		-5 to +105°C	0 to +150°C
Insulator	Irradiated cross linked foamed polyethylene	ETFE plastic		
Sheath	Polyvinyl chloride mixture		Heat-resistant polyvinyl chloride mixture	Fluonlex
Construction	8-core, 2 pairs without shield + 2 pairs with shield			
Color	Gray	Black		
Advantage	Extensible for long distances	Superior flexibility; ideal for moving place		Heat treatment and flexible; ideal for moving place

[Remark]

Contact your NSD representative when the extension cable combines different types of cables.

4. DIMENSIONS

4-1. Converter Dimension

Units: mm

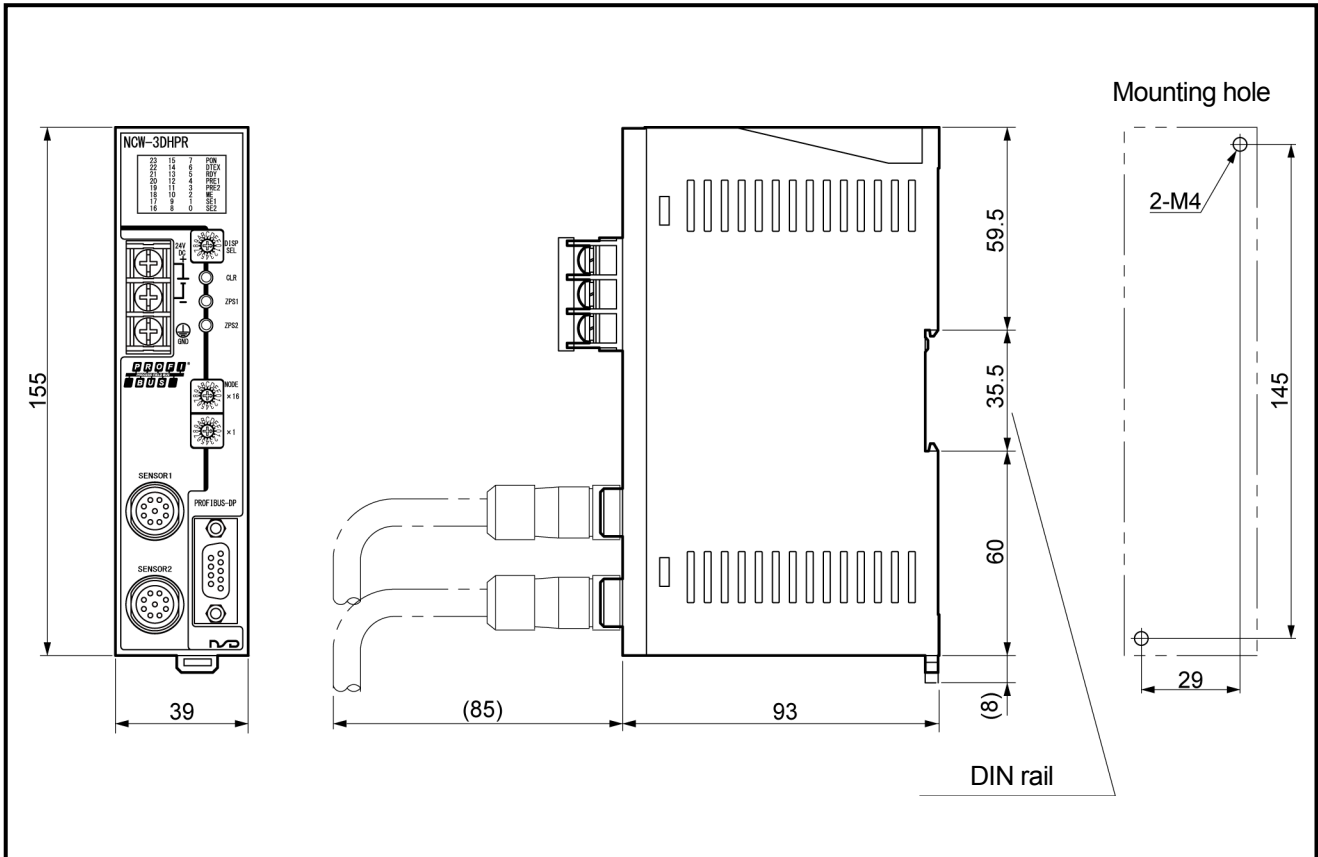

(4) MRE-[]SP074FK[] (Flange-mount type)

Units: mm

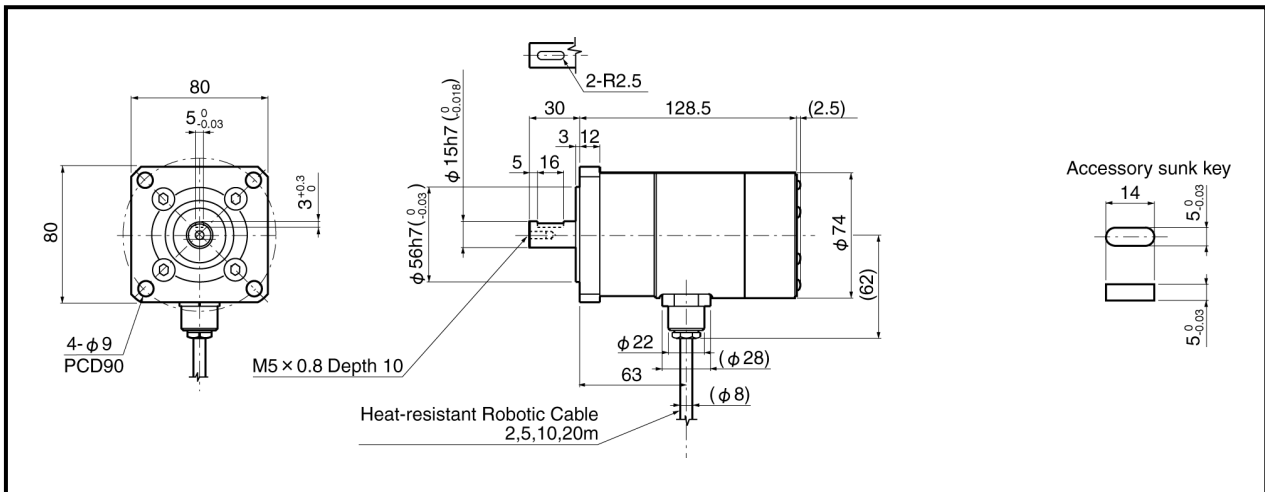

(5) MRE-[]SP074LK[] (Base-mount type)

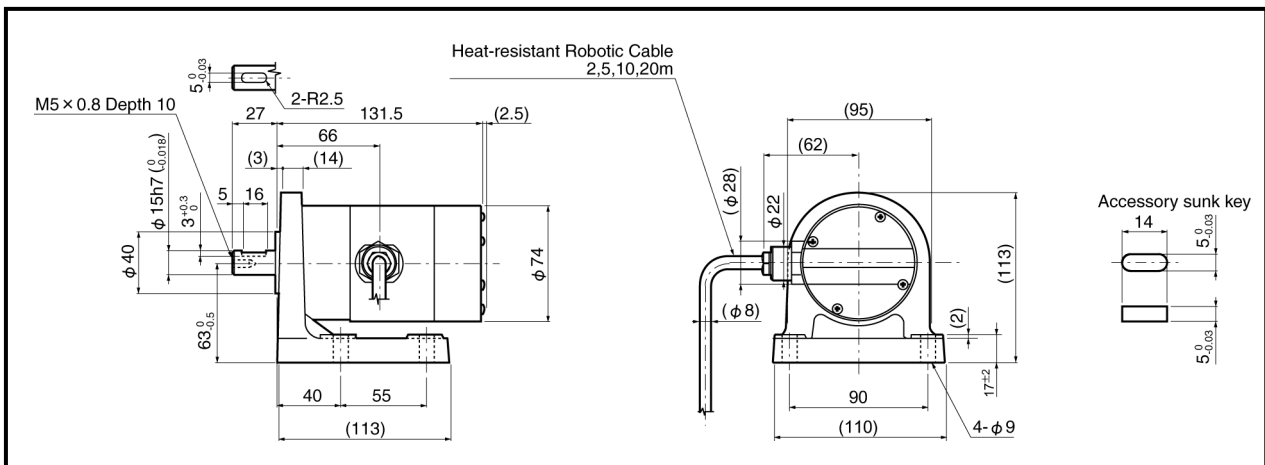

(6) MRE-[]SP074MK[] (Face-mount type)

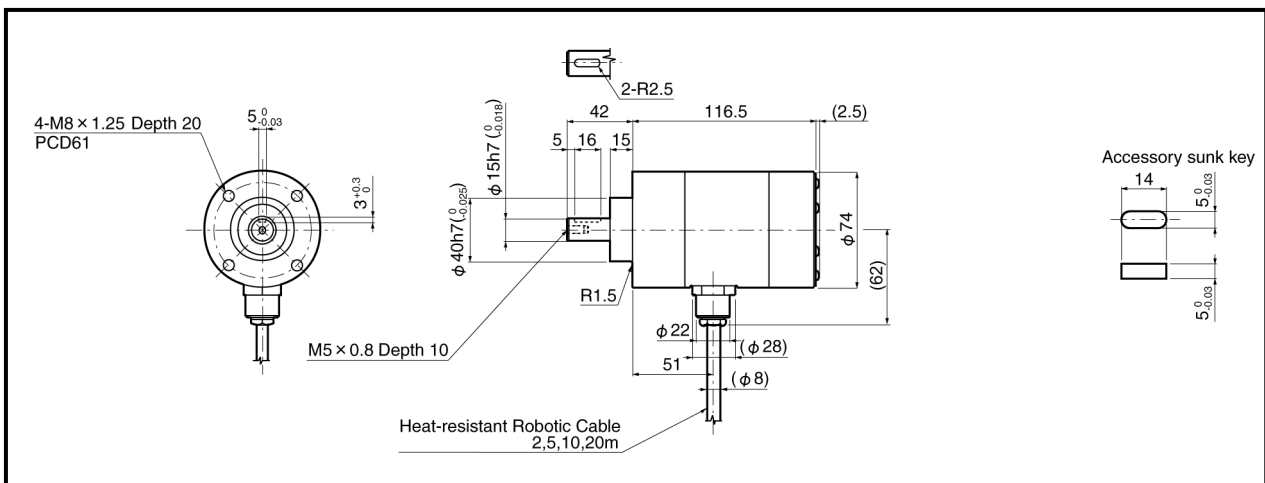

(7) MRE-[]SP097FK[] (Flange-mount type)

Units: mm

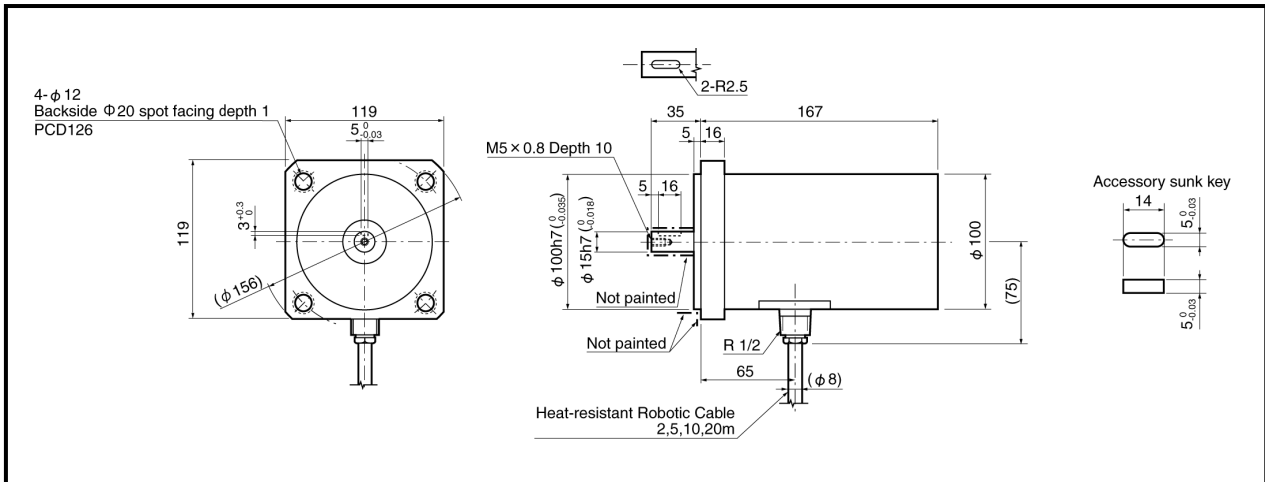

(8) MRE-[]SP097LK[] (Base-mount type)

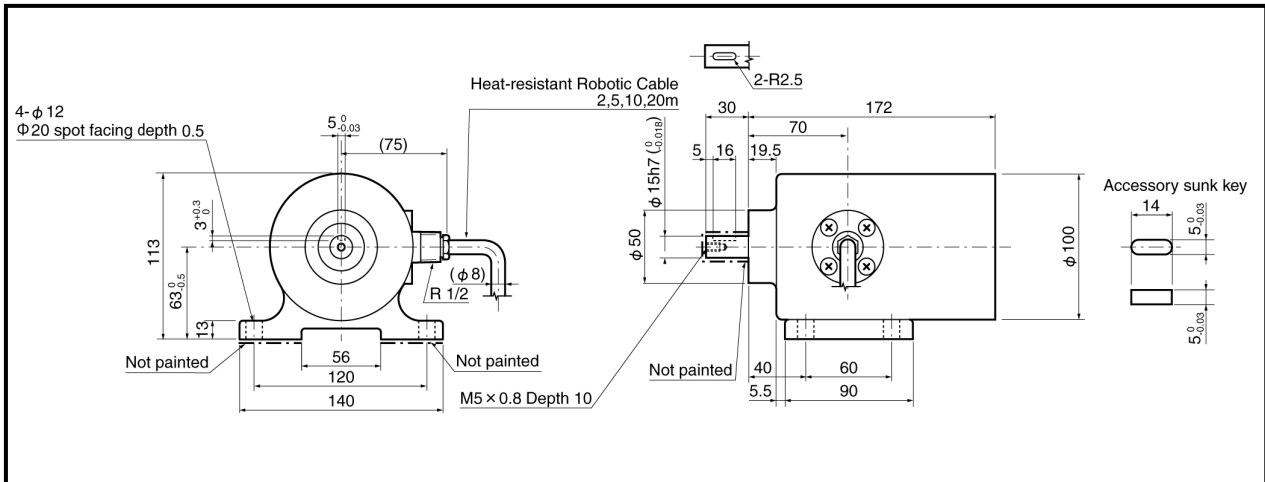

(9) MRE-[]SP101FK[] (Flange-mount type)

Units: mm

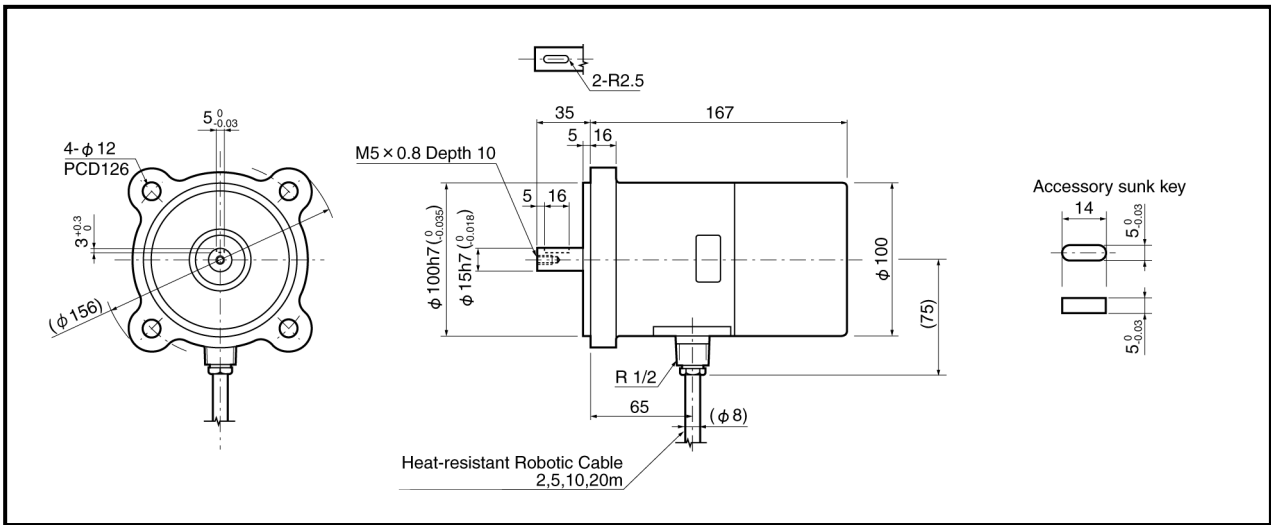

(10) MRE-[]SP101LK[] (Base-mount type)

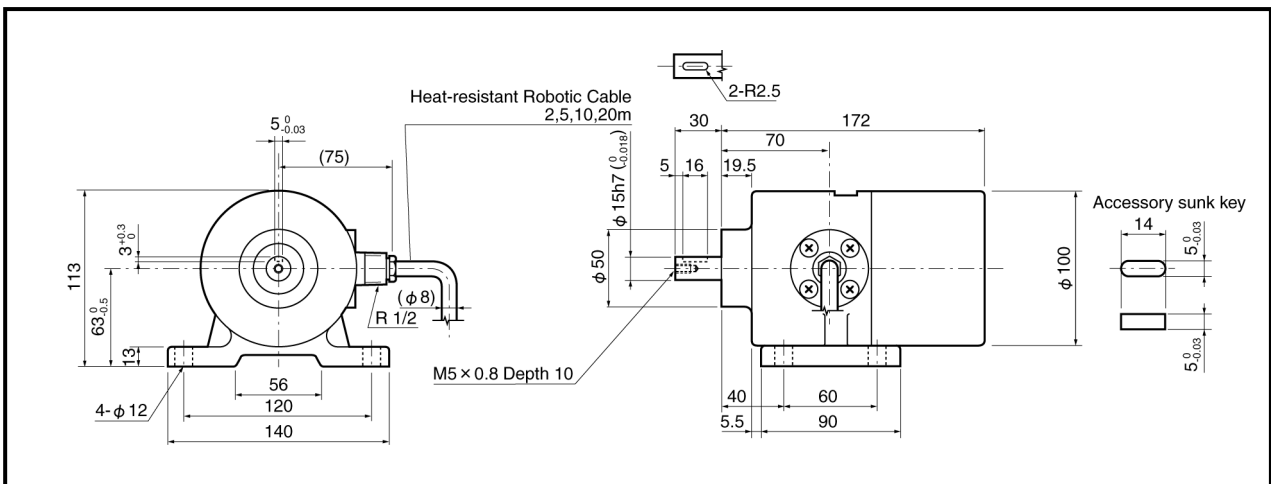

4-3. Extension Sensor Cable Dimensions

(1) 4P-S-0144-[L] / 4P-RBT-0144-[L] / 4P-URT-0144-[L]

Units: mm

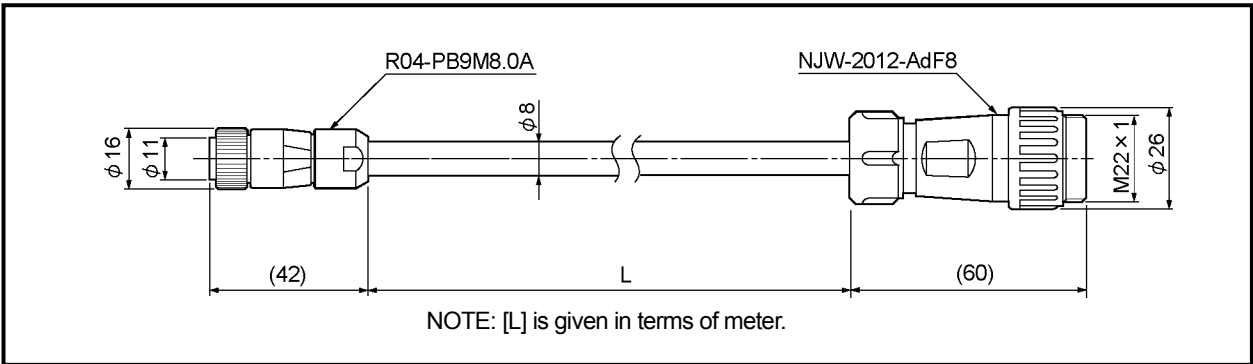

(2) 4P-S-4344-[L] / 4P-RBT-4344-[L] / 4P-URT-4344-[L] / 4P-HRT-4344-[L]

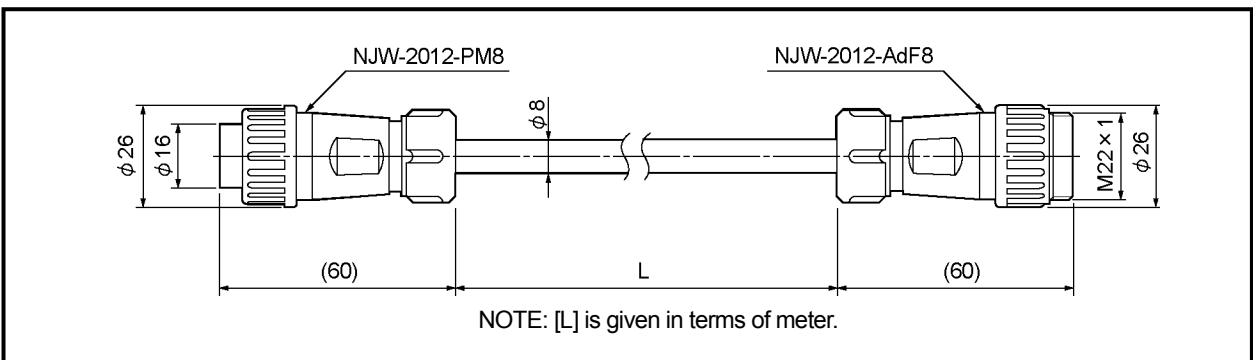

(3) 4P-S-0155-[L] / 4P-RBT-0155-[L] / 4P-URT-0155-[L]

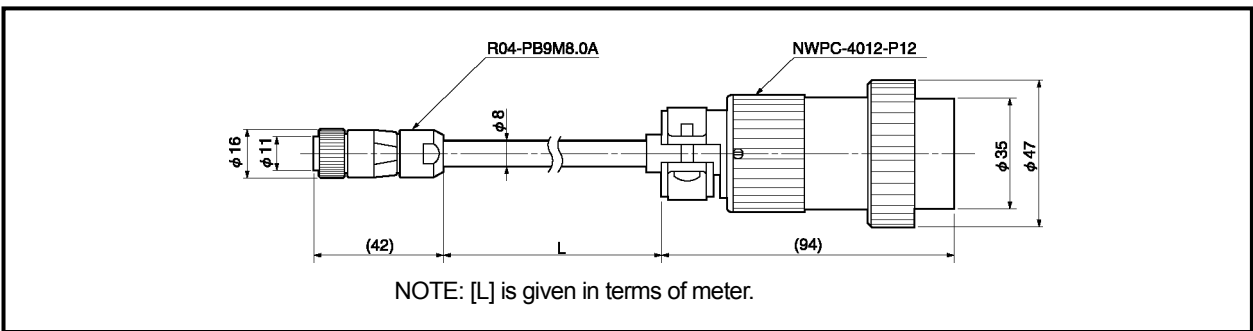

(4) 4P-S-0190-[L] / 4P-RBT-0190-[L] / 4P-URT-0190-[L]

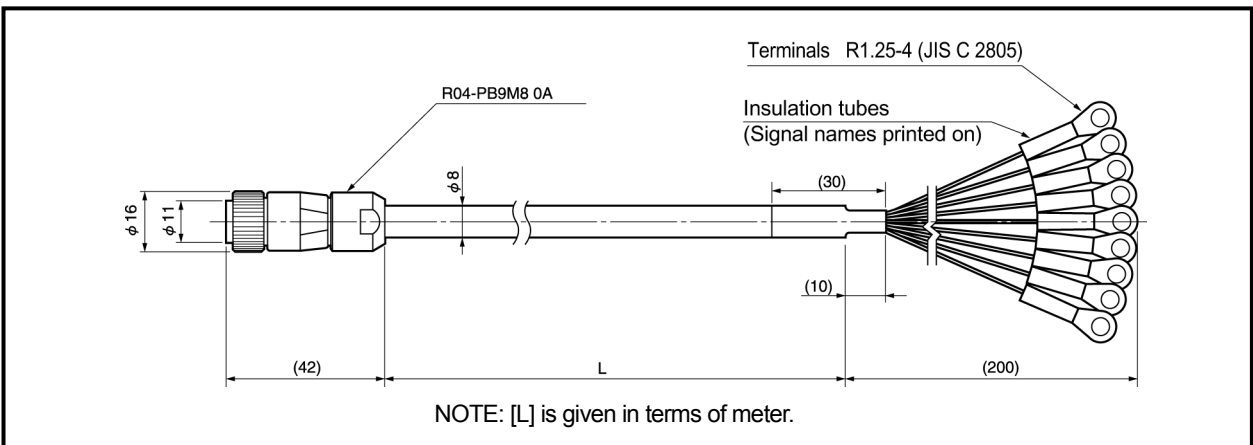

5. CHECKING THE CONTENTS OF THE SHIPPING CASE

Open the packing case, and verify that all items are present.

When extension sensor cables are ordered, they are packed separately.

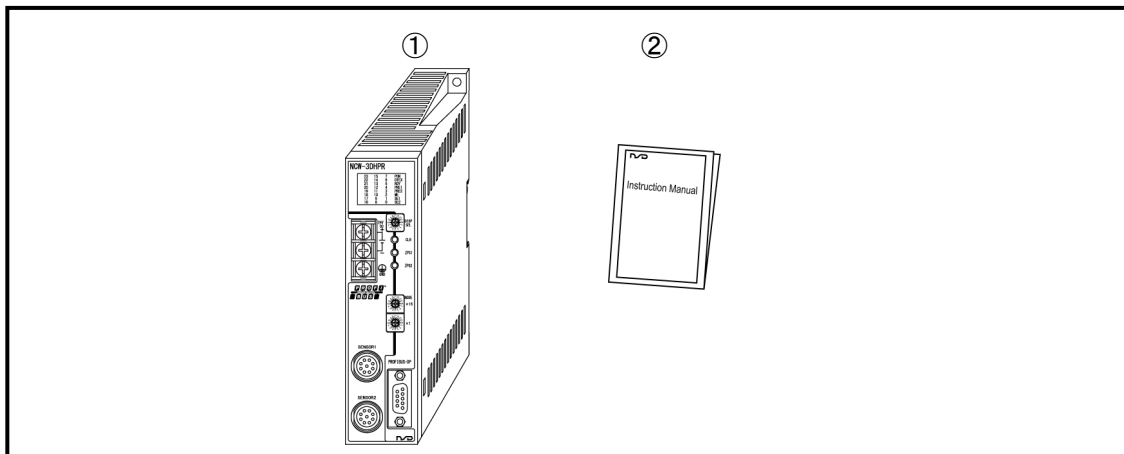

① Converter..... 1 unit

② Manual (Simple edition) 1 piece

6. INSTALLATION

6-1. Converter Installation Conditions and Precautions

When installing the converter, the following conditions and precautions should be observed.

-Installation Site

- (1) Avoid sites where the unit is exposed to direct sunlight.
- (2) The ambient temperature should never exceed a 0 to 55°C range.
- (3) The ambient humidity should never exceed a 20 to 90% RH range.
- (4) Do not install the unit in areas where condensation is likely to occur (high humidity with extreme temperature changes).
- (5) Avoid sites where dust is excessive.
- (6) Do not install in areas with an excessive amount of salt and/or metal chips.
- (7) Do not install in areas where flammable and / or corrosive gases are present.
- (8) Avoid areas where splashing water, oil or chemicals are likely to occur.
- (9) Avoid areas where vibration and shocks are excessive.

-Installation cautions

- (1) Install inside the control cabinet.
- (2) Install in a vertical direction so that the characters are visible.
- (3) If a DIN rail mounting format is used, insert until the latch mechanism catches with an audible click.
Secure between end plates at both sides.
- (4) In high vibration areas, secure tightly with 2 M4 screws.
- (5) Install as far from high voltage lines and power lines as possible in order to minimize noise influences.
- (6) Allow 85mm or more space at the converter's front side for plugging in and unplugging the connector.
- (7) Peripheral components should be arranged so as not to obstruct converter installation, removal, and connector plugging/unplugging.
- (8) Space out 10mm or more between the converter and peripheral components in order not to obstruct the converter's heat dissipation.

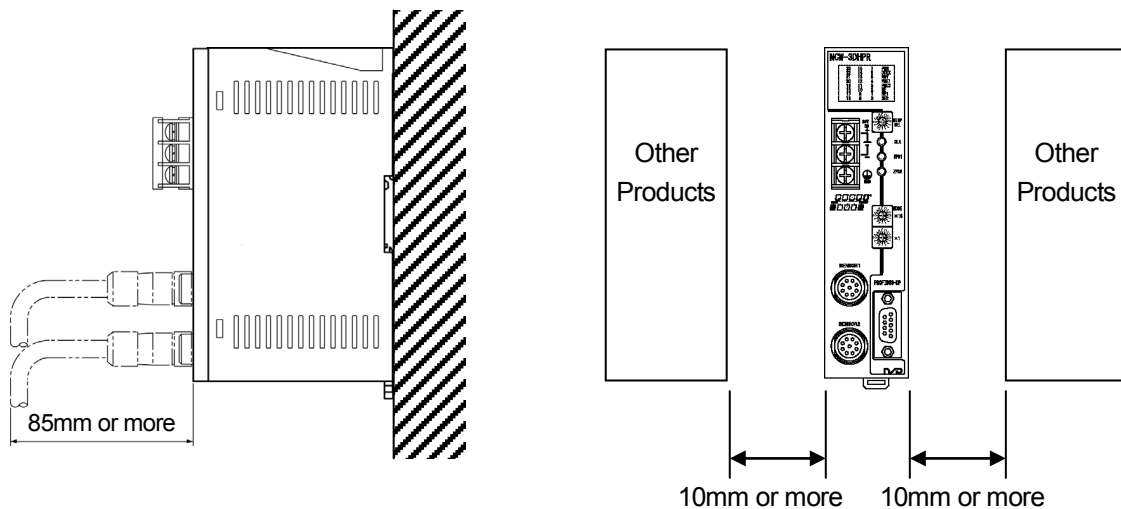

6-2. ABSOCODER Sensor Installation Conditions and Precautions

The ABSOCODER installation procedures and precautions are described in this section.



● Handling of Turn-type ABSOCODER Sensor

Item	Explanation
(1) Main unit	<p>Never drop the Sensor, or subject it to excessive forces or shocks.</p>
(2) Cable	<p>Avoid stepping on, or applying excessive stress to the cable.</p>

● Mounting of Turn-type ABSOCODER Sensor

Item	Explanation	Precaution
(1) Mounting	For details regarding mounting dimensions, refer to each ABSOCODER dimensions.	
(2) Cable port	<p>Cable port should face downward.</p>	
(3) Cable	<p>The bend radius for movable parts should never be less than 75 mm (ϕ 150) (robotic cable).</p>	Do not use the standard cable for movable parts. (Use robotic cable.)
(4) Wiring	<p>The sensor cable should be located at least 300mm away from power lines and other lines which generate a high level of electrical noise.</p>	

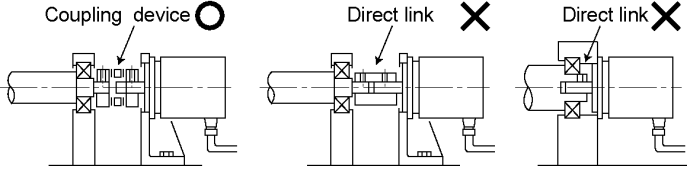
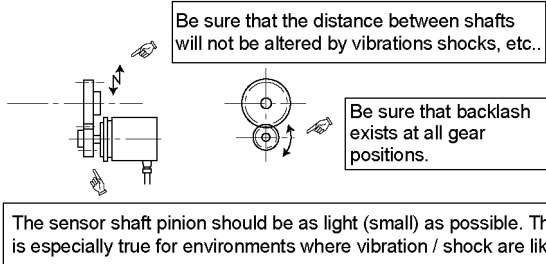
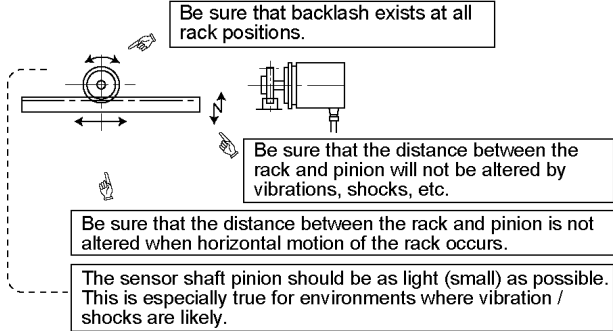
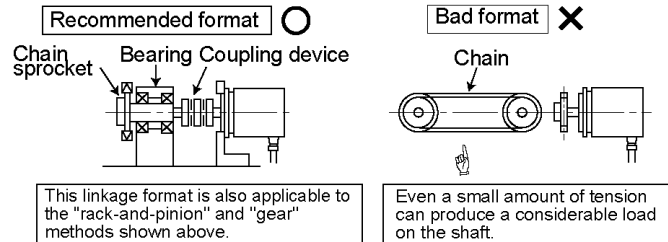
● **Mounting of Turn-type ABSOCODER Sensor**

Item	Explanation	Precaution
(1) Coupling of machine shaft and sensor shaft	<p>Be sure to use a coupling device to link the 2 shafts.</p>  <p>Coupling device ○ Direct link ✕ Direct link ✕</p>	<p>A “direct-link” format will result in shaft fatigue and / or breakage after long periods. Therefore, be sure to use a coupling device to link the shafts.</p>
(2) For gear-type linkage	<p>If a gear linkage is used, be sure that some backlash exists.</p>  <p>Be sure that the distance between shafts will not be altered by vibrations shocks, etc..</p> <p>Be sure that backlash exists at all gear positions.</p> <p>The sensor shaft pinion should be as light (small) as possible. This is especially true for environments where vibration / shock are likely.</p>	<p>Incorrect gear mounting can result in shaft bending or breakage.</p>
(3) For rack and pinion type linkage	<p>Be sure that backlash exists at all rack positions.</p>  <p>Be sure that backlash exists at all rack positions.</p> <p>Be sure that the distance between the rack and pinion will not be altered by vibrations, shocks, etc.</p> <p>Be sure that the distance between the rack and pinion is not altered when horizontal motion of the rack occurs.</p> <p>The sensor shaft pinion should be as light (small) as possible. This is especially true for environments where vibration / shocks are likely.</p>	<p>Incorrect rack and pinion mounting can result in shaft bending or breakage.</p>
(4) Chain or timing belt linkage	<p>When a chain or timing belt linkage format is used, there is an inherent risk of the shaft's load being increased by the resulting tension. Therefore, a bearing should be used, with the shafts being linked by a coupling device immediately behind the bearing.</p>  <p>Recommended format ○ Bad format ✕</p> <p>Chain sprocket Bearing Coupling device Chain</p> <p>This linkage format is also applicable to the "rack-and-pinion" and "gear" methods shown above.</p> <p>Even a small amount of tension can produce a considerable load on the shaft.</p>	
(5) Shaft mounting position	<p>The shaft should be attached to the coupling device or gear at a point which is as near to the sensor body as possible.</p>  <p>Recommended format ○ Bad format ✕ Coupling device or</p> <p>This distance should be as short as possible. When this distance is short, the load placed on the bearing by vibrations / shocks is slight.</p> <p>Never use an extended shaft format.</p>	

● Coupling of Turn-type ABSOCODER Sensor

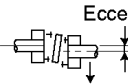
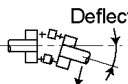
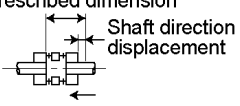
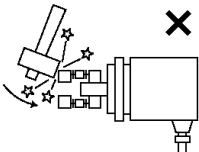
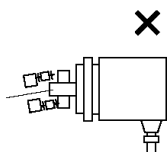
Item	Explanation	Precaution
<p>(1) Coupling device selection precaution</p>	<p>1. When selecting a coupling, consider factors such as the design mounting error, the coupling tolerance error, and the sensor's permissible shaft load.</p> <div style="display: flex; justify-content: space-around; align-items: center;"> <div style="text-align: center;"> <p>Mounting error < Coupling tolerance error</p>  <p>Load produced by eccentric condition.</p> </div> <div style="text-align: center;"> <p>Deflection</p>  <p>Load produced by deflection.</p> </div> <div style="text-align: center;"> <p>Prescribed dimension Coupling shaft permissible load < Sensor shaft load</p>  <p>Force produced by shaft direction displacement.</p> </div> </div> <div style="display: flex; justify-content: space-around; margin-top: 10px;"> <div style="text-align: center;"> <p>Radial load</p> </div> <div style="text-align: center;"> <p>Thrust load</p> </div> </div>	<p>The selection of a larger coupling than necessary will increase the shaft load which is caused by the mounting error amount.</p> <p>Excessive force applied to the shaft can deform the coupling and reduce durability.</p>
	<p>2. If the selected coupling device is larger than necessary (When used in high vibration/shock environments), the load which is applied to the shaft by the vibrations/shocks will be increased by the weight of the coupling device.</p>	
	<p>3. Be sure to select a coupling device with an adequate transmission torque surplus relative to the sensor shaft's torque.</p>	
<p>(2) Coupling device installation precaution</p>	<p>Avoid bending or damaging the coupling.</p> <div style="display: flex; justify-content: space-around; align-items: center;">   </div>	

7. WIRING

7-1. Connection between Converter and ABSOCODER Sensor

The maximum extension sensor cable length varies according to the ABSOCODER sensor and cable model being used. For more details refer to "3-2. ABSOCODER Sensor Specifications".

-Wiring Precautions

- (1) The sensor cable should be clamped as shown in the right figure to prevent excessive tension from being applied to the cable connectors.
- (2) The sensor cable should be located at least 300mm away from power lines and other lines which generate a high level of electrical noise.
- (3) If the cable is moved under the state of bending like a horseshoe, a robotic cable should be used. The bend radius should never be less than 75 mm.

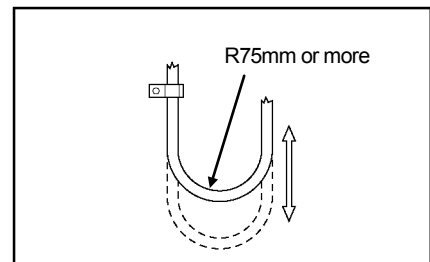
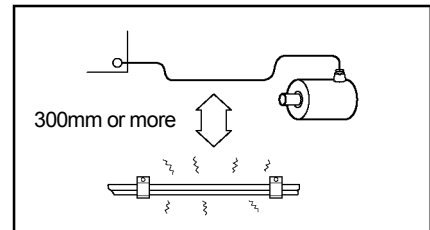
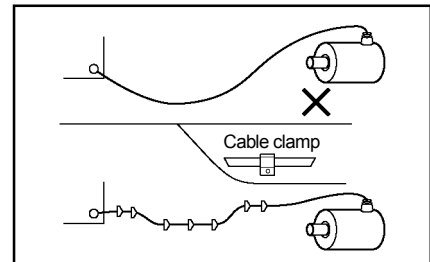

7-1-1. Connection configure example of the sensor cable

- In the case of using the NSD special cable

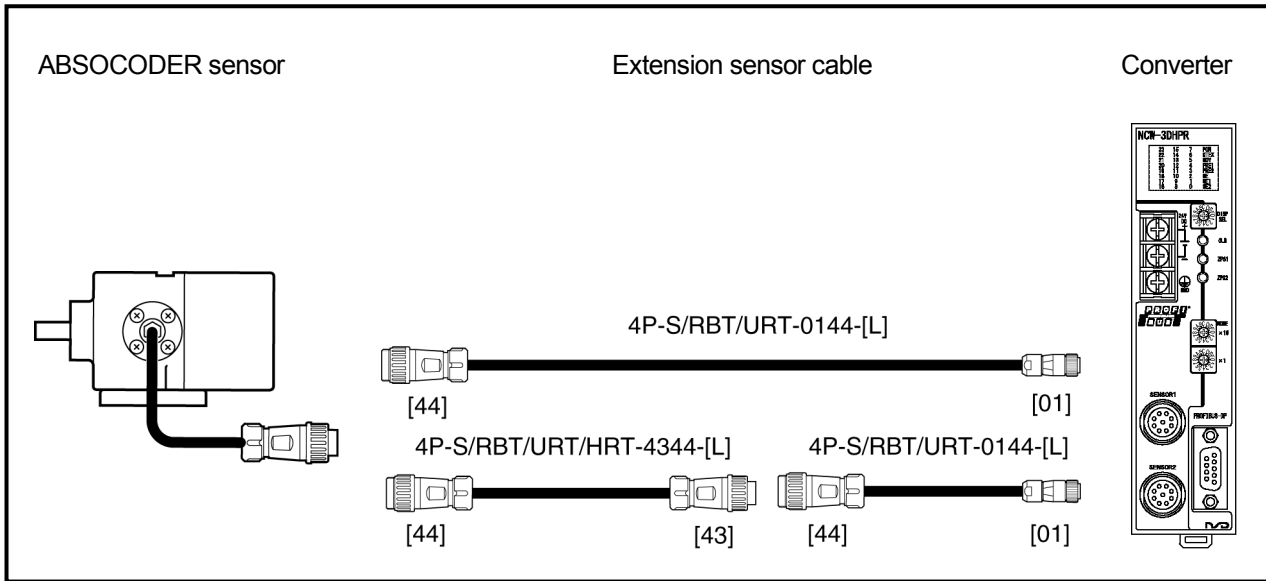

- In the case of using the commercially available cable (JKPEV-S 1.25mm² × 5P) and connecting with crimping terminals

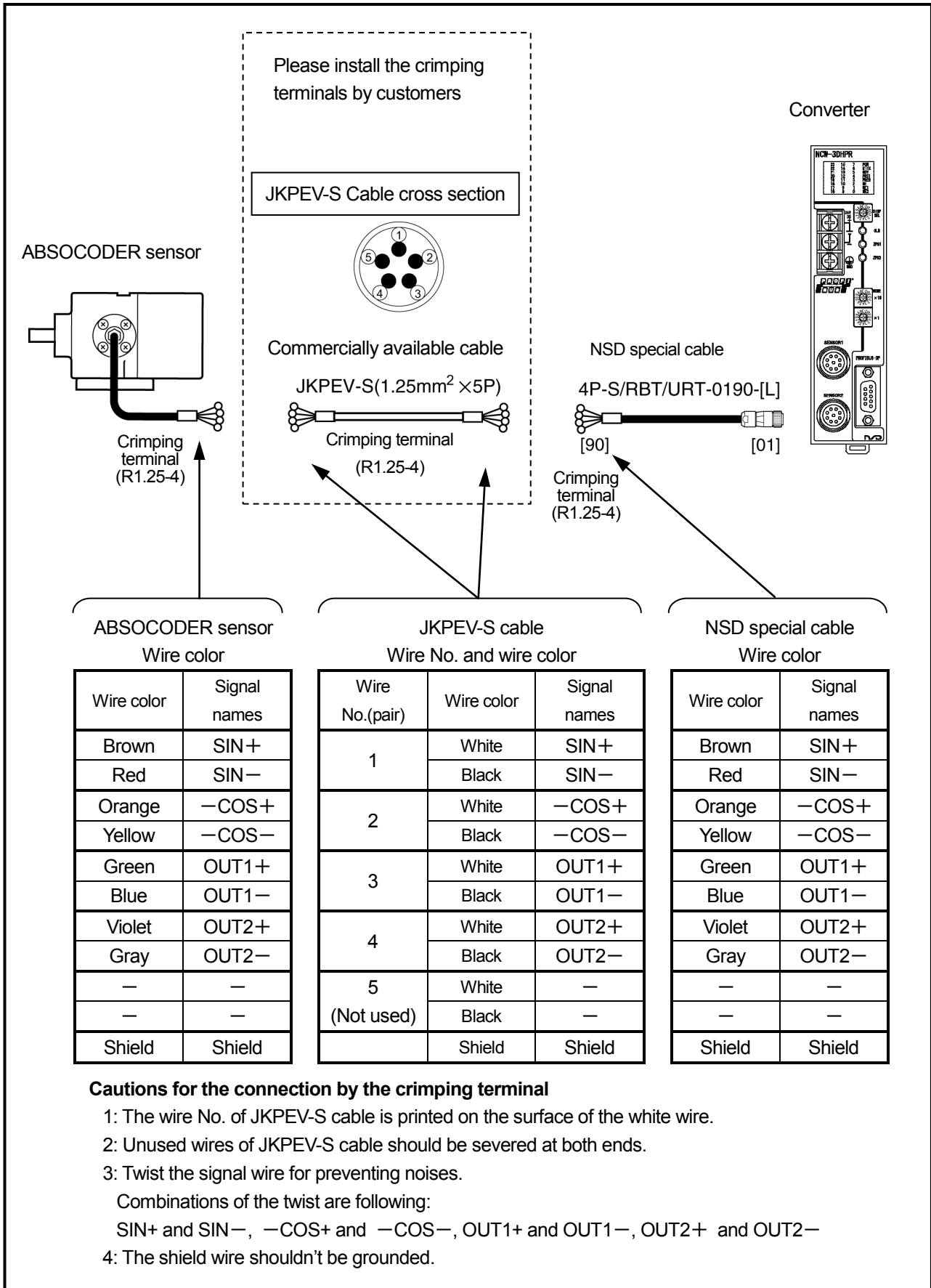

- In the case of using the commercially available cable (JKPEV-S 1.25mm²×5P) and connecting with a connector

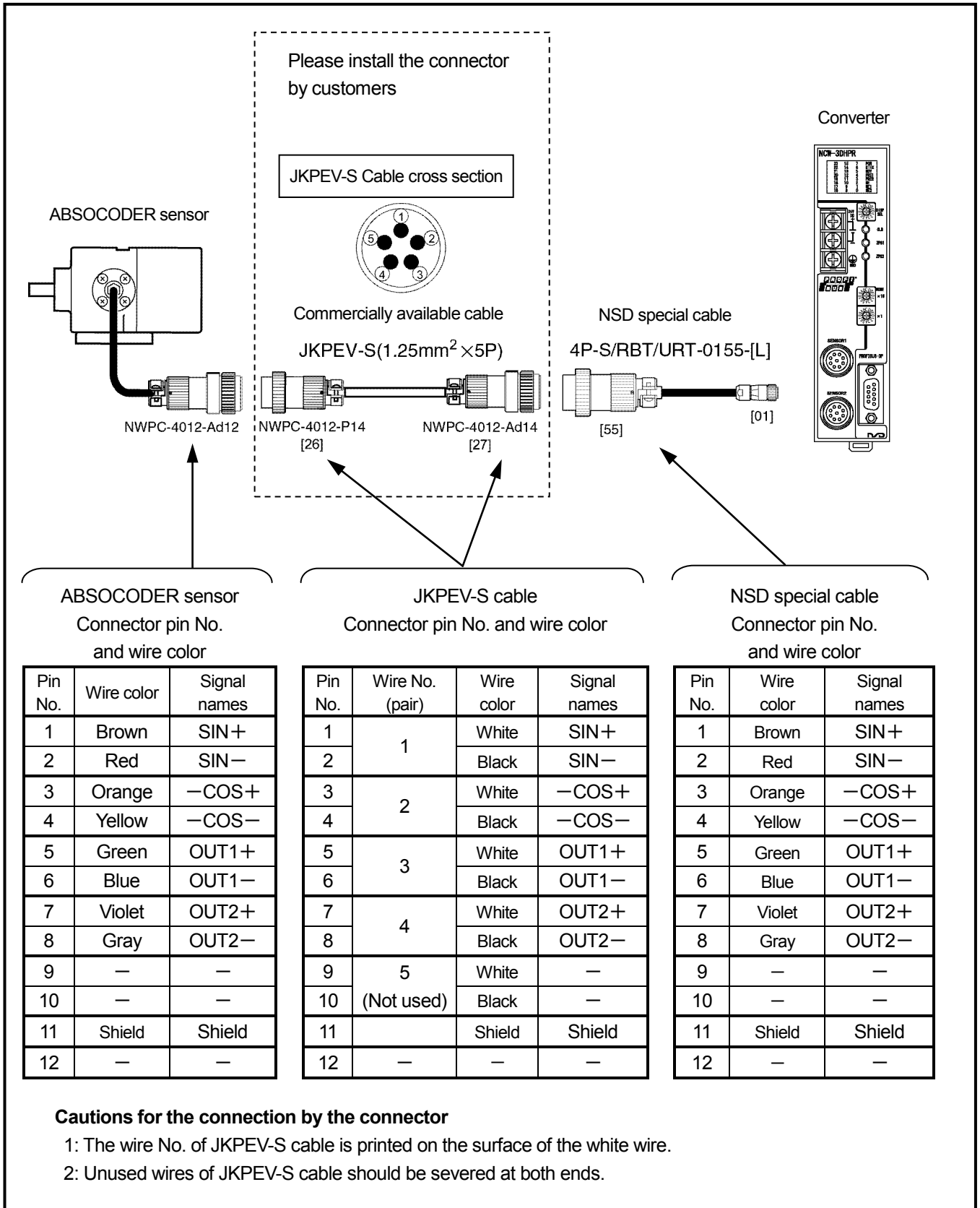

7-2. Power Supply Connection

The power supply should be connected as described below:

●Power Supply

- Choose the power supply capacity which is more than twice the power consumption of the converter.
The power consumption of the converter is 10W or less.
- The input power supply should be isolated from the commercial power supply.
- The power cable should be as thick as possible to minimize voltage drops.
- Twist the power cable for preventing noises.
- Use the M4 size crimp lug terminals with insulating sleeves in order to prevent short circuit caused by loose screws.
- The terminal block tightening torque is 1.8 N·m (16 lb·in).

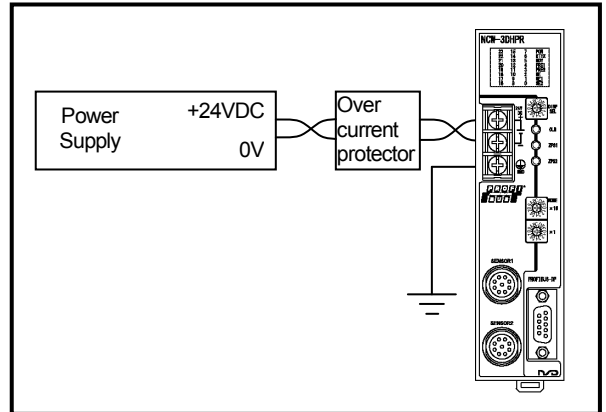

●Ground

- The unit should be securely grounded (ground resistance of 100ohm or less) to prevent electrical shocks.
- The ground wire should be connected to the ground terminal directly.
- The terminal block tightening torque is 1.8 N·m (16 lb·in).

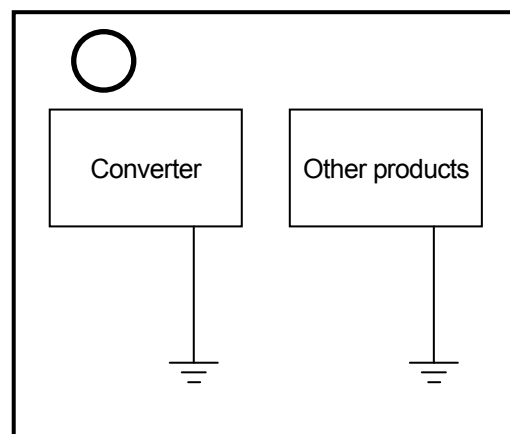
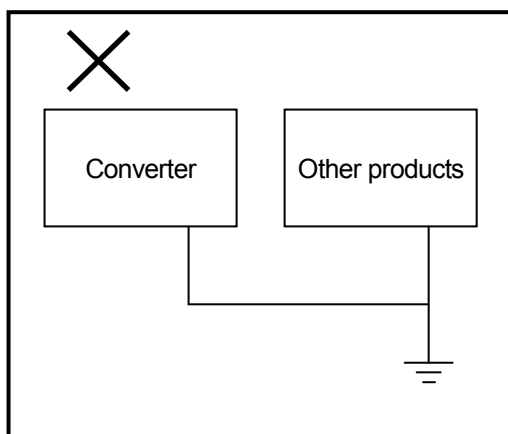

8. NOMENCLATURE

8-1. Part Identification

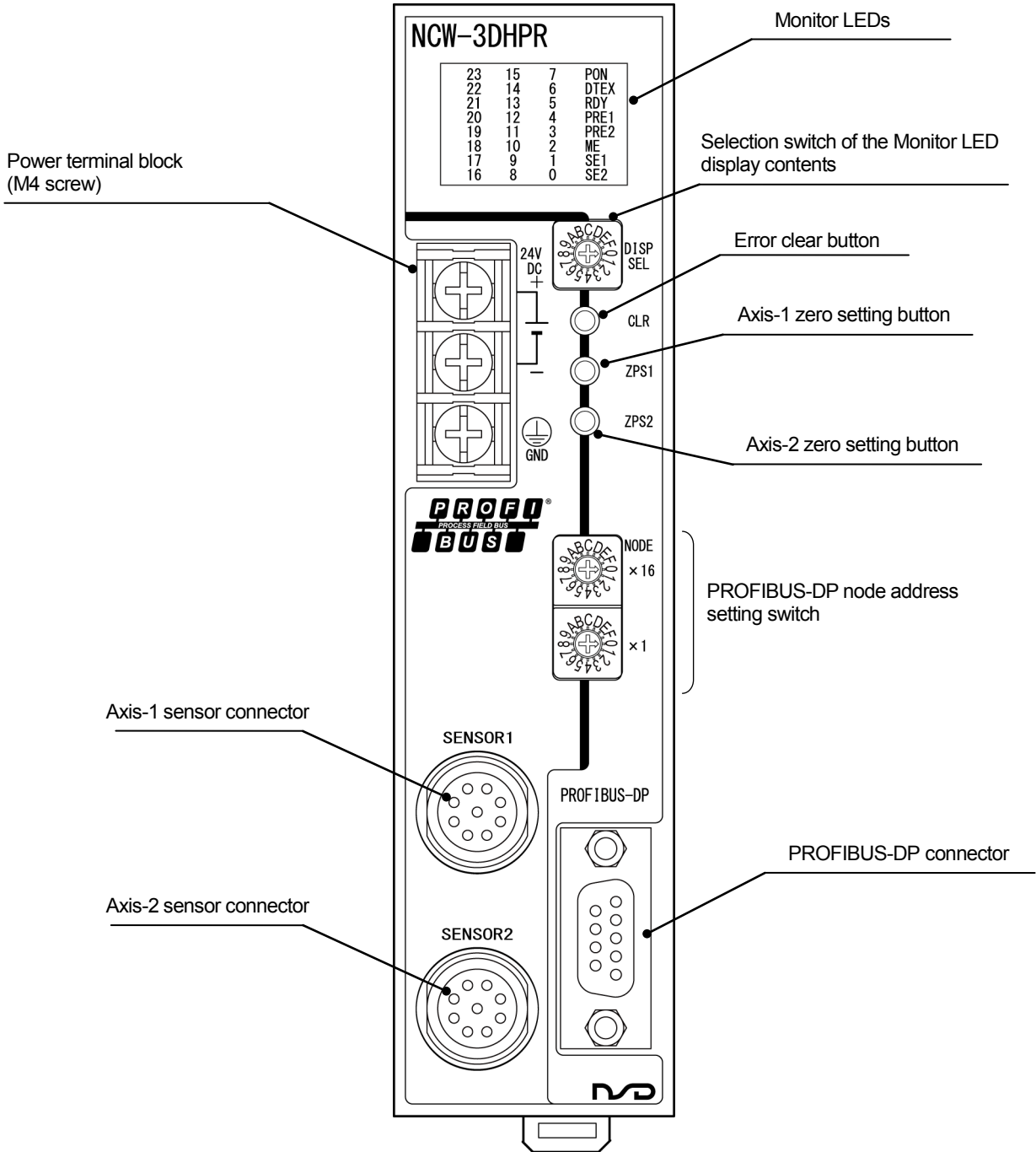

8-2. Function and Name of Display and Setting Area

8-2-1. Display contents of the monitor LEDs

Display contents on the monitor LEDs is described in this section.

NCW-3DHPR			
23	15	7	PON
22	14	6	DTEX
21	13	5	RDY
20	12	4	PRE1
19	11	3	PRE2
18	10	2	ME
17	9	1	SE1
16	8	0	SE2

Display	Description
PON	ON when the power supply is functioning normally.
DTEX	ON when PROFIBUS-DP communication is functioning normally. OFF when the converter fails to establish communication with the master by the PROFIBUS-DP configuration tool (PROFIBUS configuration software).
RDY	LED turns ON when Converter status is normal.
PRE1	ON for approximately 1 second when the preset function (zero set) operation occurs with axis-1.
PRE2	ON for approximately 1 second when the preset function (zero set) operation occurs with axis-2.
ME	ON when the memory error is occurred.
SE1	ON when the axis-1 sensor error is occurred.
SE2	ON when the axis-2 sensor error is occurred.
0-23	Monitor LED displays the content which was selected by the selecting switch (DISP SEL). For details of the display contents, refer to the next page.

Selection switch of the Monitor LED display contents (DISP SEL)

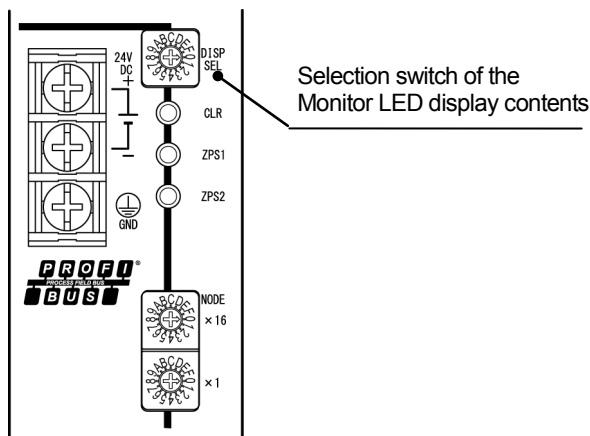

DISP.SEL	Display content
0	Axis-1 position data D0-D23
1	Axis-2 position data D0-D23
2	Axis-1 preset data D0-D23 *1
3	Axis-2 preset data D0-D23 *1
4	Previous axis-1 preset data *2
5	Previous axis-2 preset data *2
6	Sensor type *3
7	Converter diagnosis data *4
8	Parameter data *5
9-F	Unused

*1: The preset data which displays is the data transmitted from the master.

*2: Previous presetting data is displayed.

*3: The sensor type is a value of the sensor code which is set in GSD file.

	7	6	5	4	3	2	1	0
Axis-1 sensor type	Sensor code							
	15	14	13	12	11	10	9	8
Axis-2 sensor type	Sensor code							
	23	22	21	20	19	18	17	16
Unused	0							

*4: Converter's diagnosis data is displayed below. (See sections 9-3 for details).

	7	6	5	4	3	2	1	0
Axis-1 diagnosis data	0	SPF1	SSE1	0	0	0	0	SE1
	15	14	13	12	11	10	9	8
Axis-2 diagnosis data	0	SPF2	SSE2	0	0	0	0	SE2
	23	22	21	20	19	18	17	16
Converter diagnosis data	0	0	0	0	PRFPF	ME	WDTE	NRDY

*5: Parameter data is displayed below.

	7	6	5	4	3	2	1	0
Axis-1 parameter data	0	0	0	0	Data shift 1	Code sequence 1	Preset function 1	Axis unavailable 1
	15	14	13	12	11	10	9	8
Axis-2 parameter data	0	0	0	0	Data shift 2	Code sequence 2	Preset function 2	Axis unavailable 2
	23	22	21	20	19	18	17	16
Unused	0							

8-2-2. Error clear button (CLR)

Press the error clear button (CLR) on the front panel to clear the errors.

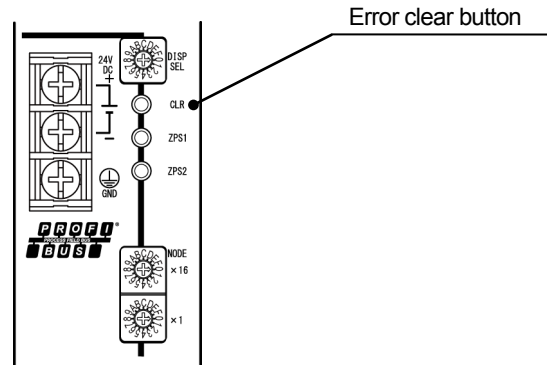

8-2-3. Zero setting button (ZPS1, ZPS2)

The position data can be changed to "0" by pressing the zero setting button (ZPS1/ZPS2) on the front panel. Move the machine to the zero-point position with no error, and press the zero setting button. ZPS1 is for axis-1, and ZPS2 is for axis-2.

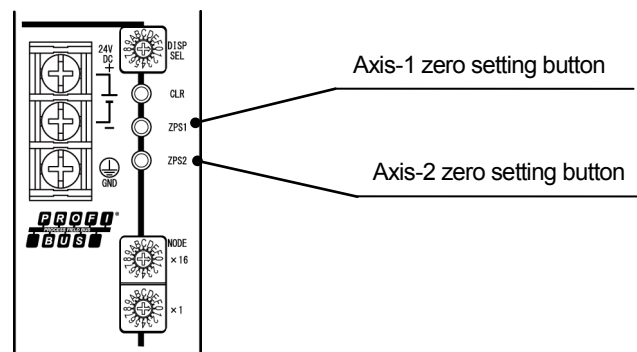

8-2-4. Node address setting switch (NODE)

Set the PROFIBUS-DP node address by the node address setting switches on the front panel. Set the address to 7DH(125) or less by 2-dgit hexadecimal number.

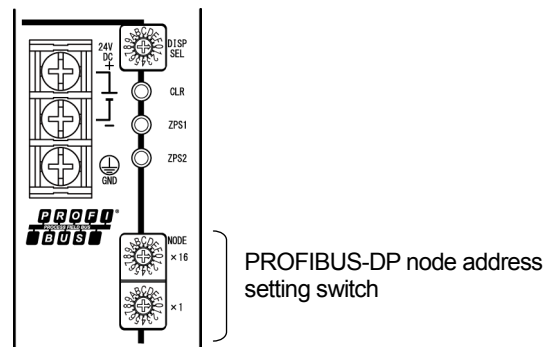

9. PROFIBUS-DP Communication

Master: PLC etc.

Slave: NCW-3DHPR

9-1. Position Data (Input Data: Slave → Master)

The position data detected by the ABSOCODER sensor can be read as Input Data by the master.

byte offset	bit7	bit6	bit5	bit4	bit3	bit2	bit1	bit0	
0	0	0	0	0	0	0	0	0	Axis-1 position data
1	0	0	0	0	0	0	0	D16 (MSB)	
2	D15	D14	D13	D12	D11	D10	D9	D8	
3	D7	D6	D5	D4	D3	D2	D1	D0 (LSB)	
4	0	0	0	0	0	0	0	0	Axis-2 position data
5	0	0	0	0	0	0	0	D16 (MSB)	
6	D15	D14	D13	D12	D11	D10	D9	D8	
7	D7	D6	D5	D4	D3	D2	D1	D0 (LSB)	

Signal name	Name	Description
D0-16	Position data	The position data detected by the ABSOCODER sensor is read. Position data range: 0 ~ 1FFFFH (0 ~ 131071) Number of effective bits: D0 - D16

9-2. Preset Data (Output Data: Master → Slave)

The master can change the position data to any desired value by performing the preset function using Output Data.

The changed position data is stored in the converter's non-volatile memory. Therefore, there is no need to do the preset function each time the power is turned on.

byte offset	bit7	bit6	bit5	bit4	bit3	bit2	bit1	bit0	
0	PRESET 1	CLR	0	0	0	0	0	0	Axis-1 preset data
1	0	0	0	0	0	0	0	PRD16 (MSB)	
2	PRD15	PRD14	PRD13	PRD12	PRD11	PRD10	PRD9	PRD8	
3	PRD7	PRD6	PRD5	PRD4	PRD3	PRD2	PRD1	PRD0 (LSB)	
4	PRESET 2	CLR	0	0	0	0	0	0	Axis-2 preset data
5	0	0	0	0	0	0	0	PRD16 (MSB)	
6	PRD15	PRD14	PRD13	PRD12	PRD11	PRD10	PRD9	PRD8	
7	PRD7	PRD6	PRD5	PRD4	PRD3	PRD2	PRD1	PRD0 (LSB)	

Signal name	Name	Description
PRD0-16	Preset data	The position data can be changed to any desired value (Preset data: PRD0-16) by setting PRESET1/PRESET2 to "1". *1, *2 Preset data range: 0 ~ 1FFFFH (0 ~ 131071) Number of effective bits: PRD0 - PRD16
PRESET1	Axis-1 preset signal	
PRESET2	Axis-2 preset signal	
CLR	Error clear signal	The following error can be cleared by setting this bit to "1". · Converter diagnosis data error (PRFPF, ME)

*1: The PRESET1/2 signal should be set to "0" if the position data is the same as the preset data. Although the position data is changed when the PRESET1/2 signal changes from "0" to "1", the position data received by the master remains the same as the preset data while the PRESET1/2 signal is "1". When the PRESET1/2 signal changes to "0", the position data at that point can be read.

(When PRESET1/2 signal is changed to 1 by the PLC pulse instruction, "1" of the PRESET1/2 signal might not be sent because of the relation between PLC scan time and Output Data update time of the PROFIBUS-DP communication.)

*2: When the PRESET1/2 signal changes from "1" to "0", the converter cannot receive another PRESET1/2 signal for a period of 100 ms.



NOTE

The preset function is disabled when a "sensor error" (SE) occurs.

(1) Preset timing

The position data is changed by the preset data (PRD0-PRD16) and PRESET signal (1 bit) which are written from the master.

The response time from the point when the PRESET signal changes from “0” to “1”, until the preset setting occurs, is shown below.

Actual timing depends on scanning time of PLC and updating time of PROFIBUS-DP.

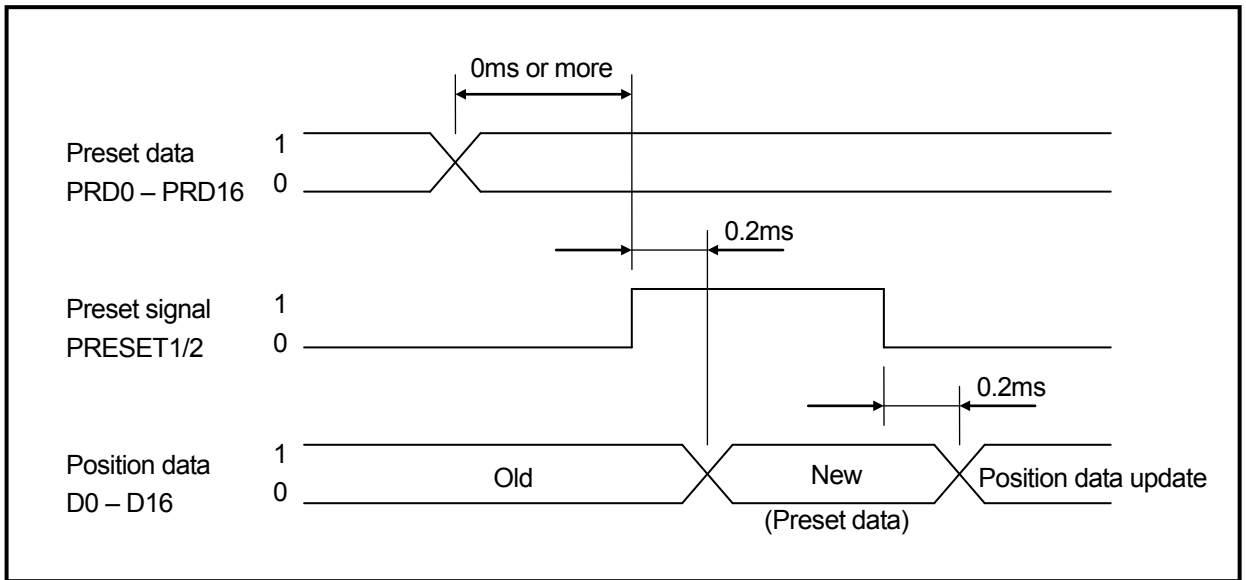

The PRESET signal should change from “0” to “1”, after the Preset data are written. (0 ms or more)

	NOTE
While the PRESET1/2 signal is “1”, the position data doesn't update.	

(2) Program for preset function

A program example which executes a preset function is shown below.

Conditions

The following signal assignments are used to control the NCW-3DHPR.

HW Config - [SIMATIC 300 Station (Configuration) -- S7_Pro4]

Station Edit Insert PLC View Options Window Help

UR

1	CPU315-2 PN/DP(1)
X1	MPI/DP
X2	PN-IO
X2 P1	Port 1
X2 P2	Port 2
3	
4	DI64xDC24V
5	DO64xDC24V/0.3A, M
6	
7	
8	

PROFIBUS(1): DP master system (1)

(2) ABSOCODER

Sl.	DP ID	Order Number / Designation	I Address	Q Address	Comment
1	55	NCW-3DHPRM2R	4..11	8..15	
2					

PROFIBUS DP

- Additional Field Devices
 - General
 - ABSOCODER
 - Universal module
 - VE-2PR STYLE1
 - VE-2PR-V1R STYLE1
 - VE-2PRH-V1R
 - VE-2PR-V1 STYLE1
 - VE-2PR-V2 STYLE1
 - VE-2PRH-V2
 - VL-2PR-LP STYLE1
 - VM-2PR STYLE1
 - VM-2PR-M2R STYLE1
 - VM-2PRH-M2R
 - VM-2PR-M2 STYLE1
 - VL-2PR-L STYLE1
 - VL-2PR-LC STYLE1
 - VL-2PRH-LC
 - VE-2PR STYLE2
 - NCW-3DNPRVP
 - NCW-3DNPRV2
 - NCW-3DNPRMP
 - NCW-3DNPRL
 - NCW-3DHPRV1R
 - NCW-3DHPRV2
 - NCW-3DHPRM2R
 - NCW-3DHPRLC
 - NCW-3DHPRBLC
 - NCW-3DHPRCLC
 - NCW-3DHPRL8
 - Switching Devices

Press F1 to get Help.

Axis-1 preset instruction to NCW-3DHPR	I20.0
NCW-3DHPR's axis-1 position data display	Q30.0 ~ Q33.7
NCW-3DHPR's axis-1 sensor alarm detection	Q34.0
NCW-3DHPR's axis-1 "preset completed" display	Q34.1
Input data from NCW-3DHPR	I4.0 ~ I11.7
Output data to NCW-3DHPR	Q8.0 ~ Q15.7
Error readout input	M0.0
During readout an error	M0.1
Error code output	MW10
NCW-3DHPR unit address	2043 (#7FB)

Program example

Block: OB1

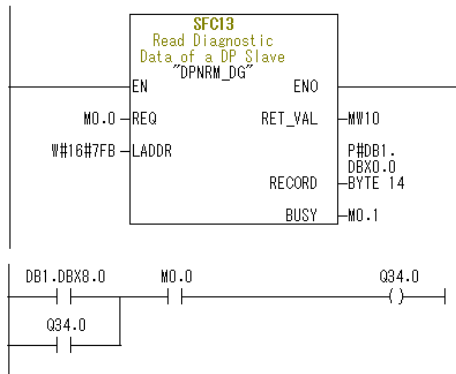

Alarm check

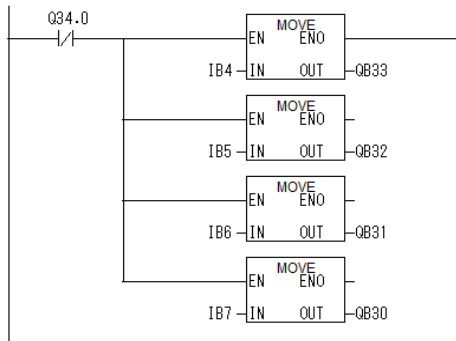

Axis-1 "sensor alarm" display

Axis-1 "position data" readout

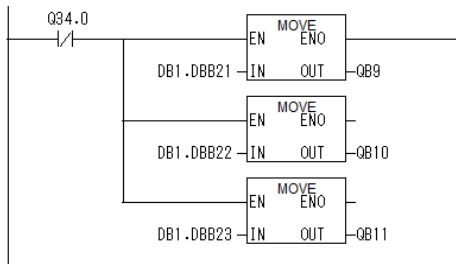

Axis-1 "preset data" setting

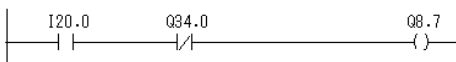

Axis-1 "preset" instruction

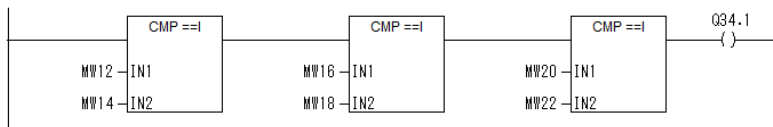

Axis-1 "preset completed" display

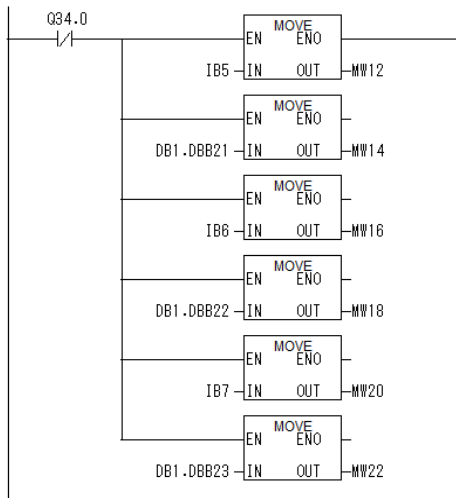

Change data type
byte ⇒ int

Alarm detection program Block: OB82

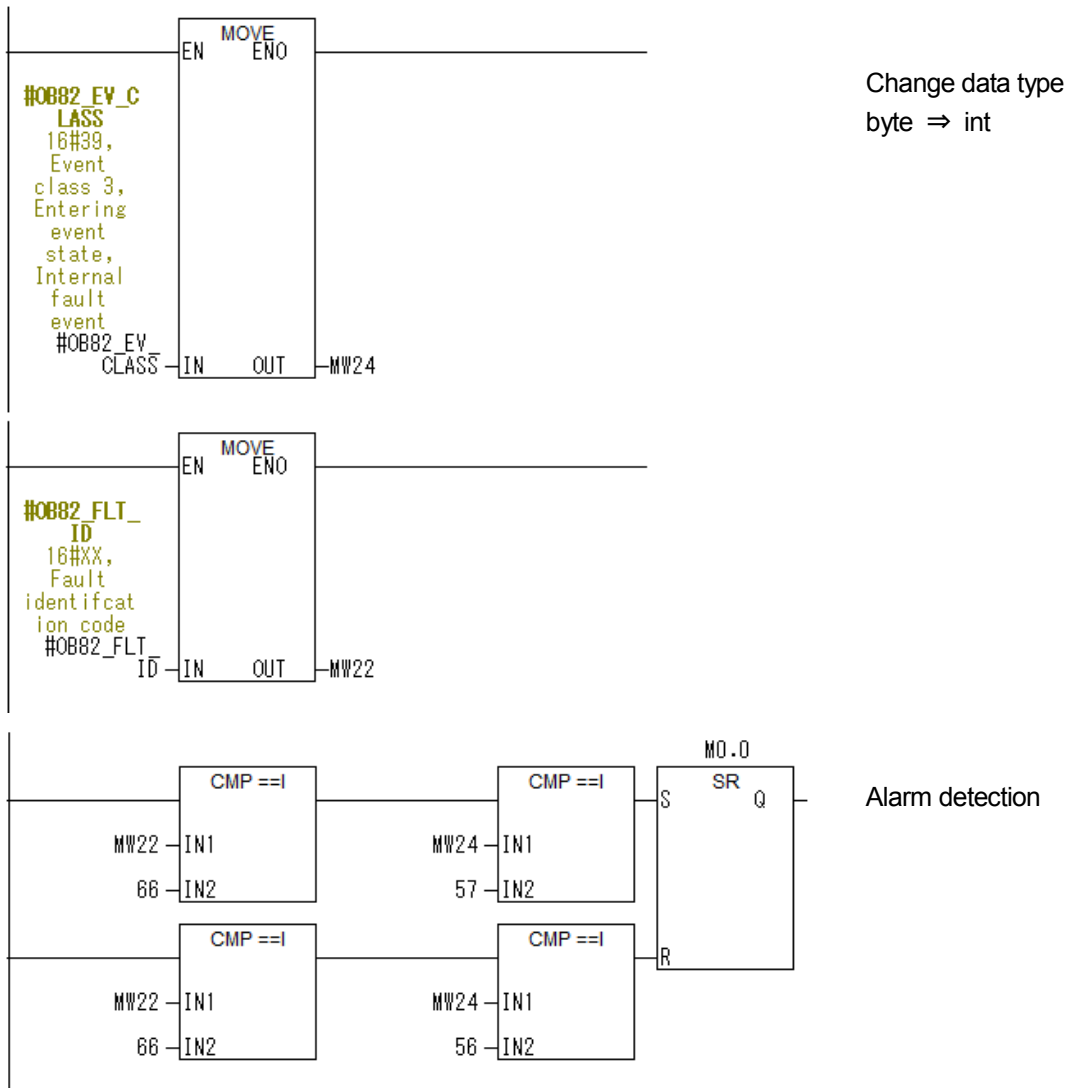

Data block area Block: DB1
 Secures the data block area for preset setting.

Address	Name	Type	Initial value	Comment
0.0		STRUCT		
+0.0	DB_VAR	ARRAY[1..250]		Temporary placeholder variable
*1.0		BYTE		
=250.0		END_STRUCT		

9-3. Alarm Data (Extended Diagnostic Data)

The alarm data is shown below.

byte offset	bit7	bit6	bit5	bit4	bit3	bit2	bit1	bit0	
0	Master_Lock	Prm_Fault	Invalid_Slave_Response	Not_Supported	Ext_Diag	Cfg_Fault	Station_Not_Ready	Station_Non_Existent	Standard Diagnosis Information
1	Deactivated	0	Sync_Mode	Freeze_Mode	Wd_On	set to 1 by slave	Stat_Diag	Prm_Req	
2	Ext_Diag_Overflow	0	0	0	0	0	0	0	
3	Master Address								
4	Ident_Number High Byte								
5	Ident_Number Low Byte								
6	0	0	0	0	1	0	0	0	Extended Diagnostic Header
7	0	0	0	0	PRFPF	ME	WDTE	NRDY	Converter diagnosis data
8	0	SPF1	SSE1	0	0	0	0	SE1	Axis-1 diagnosis data
9	0	0	0	0	0	1	1	1	Axis-1 sensor type
10	0	0	0	0	0	0	0	0	
11	0	SPF2	SSE2	0	0	0	0	SE2	Axis-2 diagnosis data
12	0	0	0	0	0	1	1	1	Axis-2 sensor type
13	0	0	0	0	0	0	0	0	

* The byte offset 0~5 data (Standard Diagnosis Information) is the standard diagnosis data for the PROFIBUS-DP slave.

Error Name	Description	When Detected	Status	CLEAR Method	Countermeasure
PRFPF	PROFIBUS-DP power supply error (Error is "1") Problem exists at converter's internal power supply. As communication is disabled, check the PRFPF lamp at the LED display.	Always	This converter is not recognized by PROFIBUS-DP.	CLR	If there are no problems with the PROFIBUS-DP cable or communication, the converter has failed.
ME	Memory error (Error is "1") A data memory error has occurred.	At power ON	An undetermined position data status exists at both axes.	CLR	Converter failure.
WDTE	Watchdog timer error (Error is "1") Runaway condition at the internal CPU.	Always	An undetermined position data status exists at both axes.	Restart	Converter failure.
NRDY	Not Ready (Error is "1" or operation not yet started; Normal is "0") One of PRFPF, ME, or WDTE error has occurred.	Always	An undetermined position data status exists at both axes.	Comply with each error clear method.	
SPF1 SPF2	The internal power supply error for sensors (Error is "1") The power supply inside of the converter is broken down.	Always	An undetermined position data status exists at both axes.	CLR	Converter failure.
SSE1 SSE2	Disconnected sensor error (Error is "1") The sensor of a correspondence axis is not connected normally.	Always	The position data of the axis which has an error is "undetermined data".	Automatic recovery	- Sensor connector is loose. - Sensor cable is severed. - ABSOCODER sensor failure - Converter failure.
SE1 SE2	Sensor error (Error is "1") Either SPF or SSE has occurred.	Always		Comply with each error clear method.	

(1) Program for alarm detection

A program example for alarm readouts and alarm clear operation is shown below.

Conditions

The following signal assignment is used to control the NCW-3DHPR.

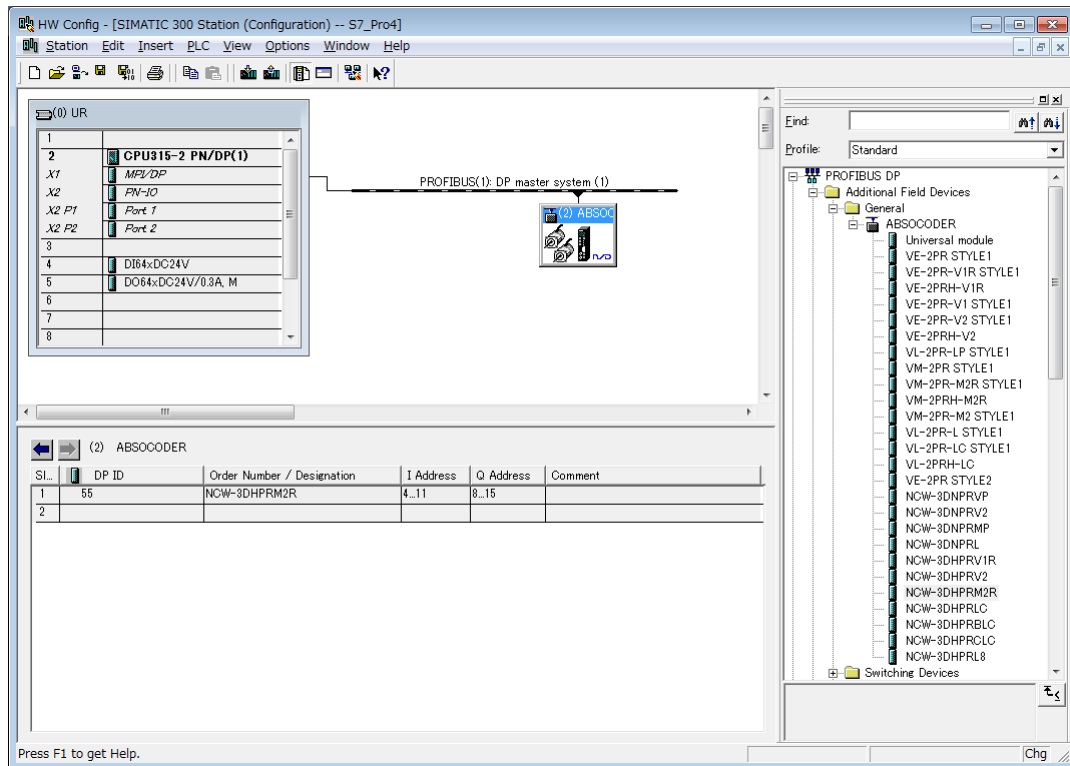

“Alarm clear” instruction to NCW-3DHPR	I20.0
NCW-3DHPR’s NRDY (Not Ready) display	Q30.0
NCW-3DHPR’s WDTE (Watchdog timer error) display	Q30.1
NCW-3DHPR’s ME (Memory error) display	Q30.2
NCW-3DHPR’s PRFPF (PROFIBUS-DP power supply error) display	Q30.3
NCW-3DHPR’s SE1 (axis-1 sensor error) display	Q30.4
NCW-3DHPR’s SE2 (axis-2 sensor error) display	Q30.5
Input data from NCW-3DHPR	I4.0 ~ I11.7
Output data to NCW-3DHPR	Q8.0 ~ Q15.7
Error readout input	M0.0
During readout an error	M0.1
Error code output	MW10
NCW-3DHPR unit address	2043 (#7FB)

Program example
Main program Block: OB1

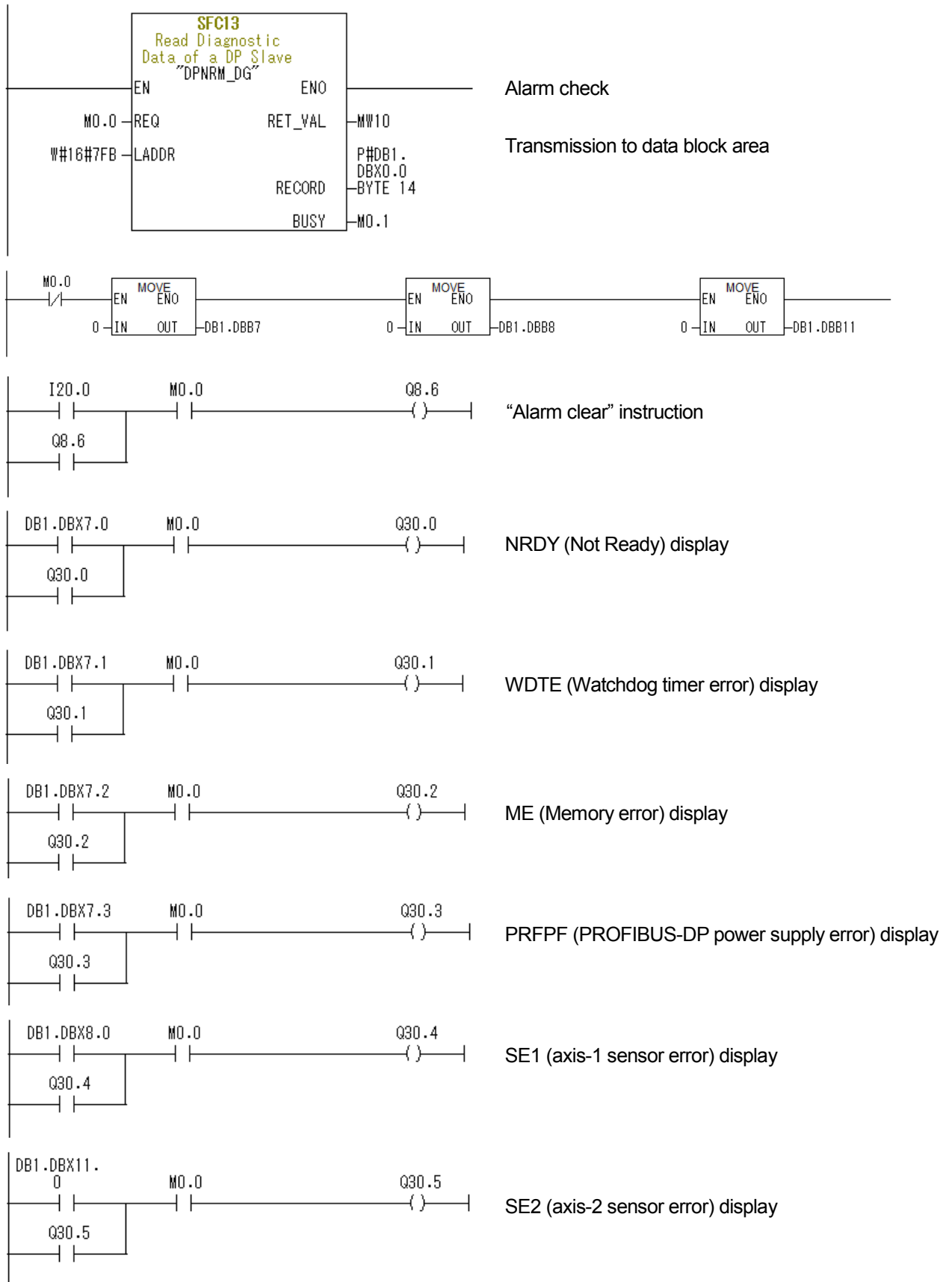

Alarm detection program Block: OB82

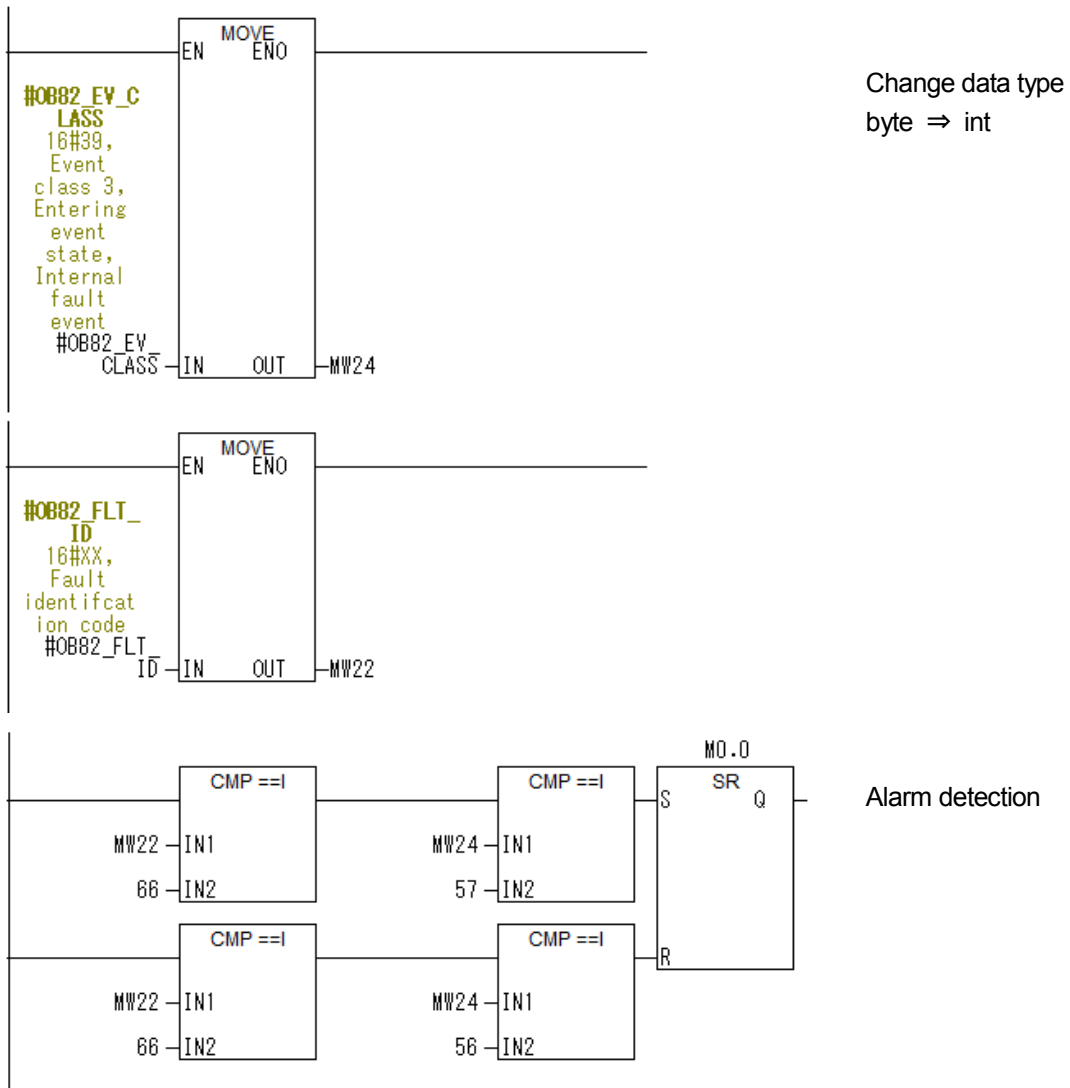

Data block area Block: DB1

Secures the data block area for Alarm detection.

Address	Name	Type	Initial value	Comment
0.0		STRUCT		
+0.0	DB_VAR	ARRAY[1..250]		Temporary placeholder variable
*1.0		BYTE		
=250.0		END_STRUCT		

9-4. Parameter Data

Parameter data is set at the PROFIBUS-DP configuration tool (PROFIBUS configuration software) when the system is started up.

byte offset	bit7	bit6	bit5	bit4	bit3	bit2	bit1	bit0	
0	0	0	0	0	0	*	*	*	For system
1	0	0	0	0	Data shift 1	Code sequence 1	Preset function 1	Axis unavailable 1	Axis-1 parameter data
2	0	0	0	0	0	0	0	0	
3	0	0	0	0	0	1	1	1	
4	0	0	0	0	Data shift 2	Code sequence 2	Preset function 2	Axis unavailable 2	Axis-2 parameter data
5	0	0	0	0	0	0	0	0	
6	0	0	0	0	0	1	1	1	



NOTE

* These are system parameters. Do not change the GSD file values.

(1) "Axis unavailable" (sensor disabled) settings

This setting determines the ABSOCODER sensor's enabled/disabled status. (Default=0)

bit0	Selection Content	Description
0	Available	Enables the connected ABSOCODER sensor for position detection.
1	Unavailable	Disables the sensor for this axis. When this setting is specified, the "sensor error" does not display. The position data is always "0".

(2) "Preset function" settings

This setting enables/disables the zero setting and preset function. (Default=0)

bit1	Selection Content	Description
0	Enable	Enables the zero setting and preset function.
1	Disable	Disables the zero setting and preset function.

(3) "Code sequence" (position data increase direction) settings

This setting determines the ABSOCODER sensor rotation direction in which the position data value increases. (Default=0)

bit2	Selection Content	Description
0	CW	The position data value will increase when the shaft turns in the clockwise direction as viewed from the shaft end.
1	CCW	The position data value will increase when the shaft turns in the counterclockwise direction as viewed from the shaft end.

◆ Shaft rotation direction

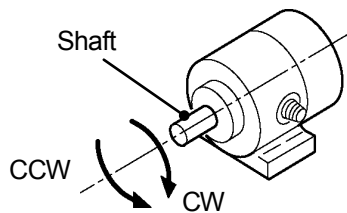

(4) "Data shift" (position data shift) settings

This setting determines the position data's number of effective divisions. (Default=0)

bit3	Selection Content	Description
0	Not shift	Specifies the position data as the enabled number of bits.
1	Shift	When there are 17 effective bits, a 1-bit right-shift occurs, with the position data being specified as 16 bits. (Refer to the following table)

Position Data (Input Data)

The image of 1-axis position data shift is indicated below as an example.

byte offset 1	byte offset 2								byte offset 3							
bit 0	bit 7	bit 6	bit 5	bit 4	bit 3	bit 2	bit 1	bit 0	bit 7	bit 6	bit 5	bit 4	bit 3	bit 2	bit 1	bit 0
D16	D15	D14	D13	D12	D11	D10	D9	D8	D7	D6	D5	D4	D3	D2	D1	D0
	D16	D15	D14	D13	D12	D11	D10	D9	D8	D7	D6	D5	D4	D3	D2	D1

10. INSPECTION

The inspection should be conducted once every 6 months to a year.

Any inspected items which do not satisfy the criteria shown below should be repaired

Inspection item	Inspection Description	Criteria	Remark
Power supply	Measure the voltage fluctuation at the power supply terminal block of the converter to determine if it is within the prescribed range.	Within 21.6V to 26.4VDC range	Tester
Ambient Conditions	Check the ambient temperature.	ABSOCODER sensor MRE-[]SP061: -20 to +80°C MRE-[]SP074: -20 to +120°C MRE-[]SP097: -20 to +120°C MRE-[]SP101: -20 to +120°C Converter: 0 to +55°C	Thermometer
	There should be no accumulation of dust.	None	
Mount Conditions	Verify that the sensor is securely mounted.	There should be no looseness.	Visual Inspection
	Verify that the sensor shaft is securely coupled to the machine shaft.	There should be no looseness.	
	Check for severed cables.	Cable should appear normal.	
	Verify that the sensor cable connector is plugged in all the way.	There should be no looseness.	
	Verify that the PROFIBUS-DP connector is plugged in all the way.	There should be no looseness.	

11. Troubleshooting

11-1. Troubleshooting Flowchart

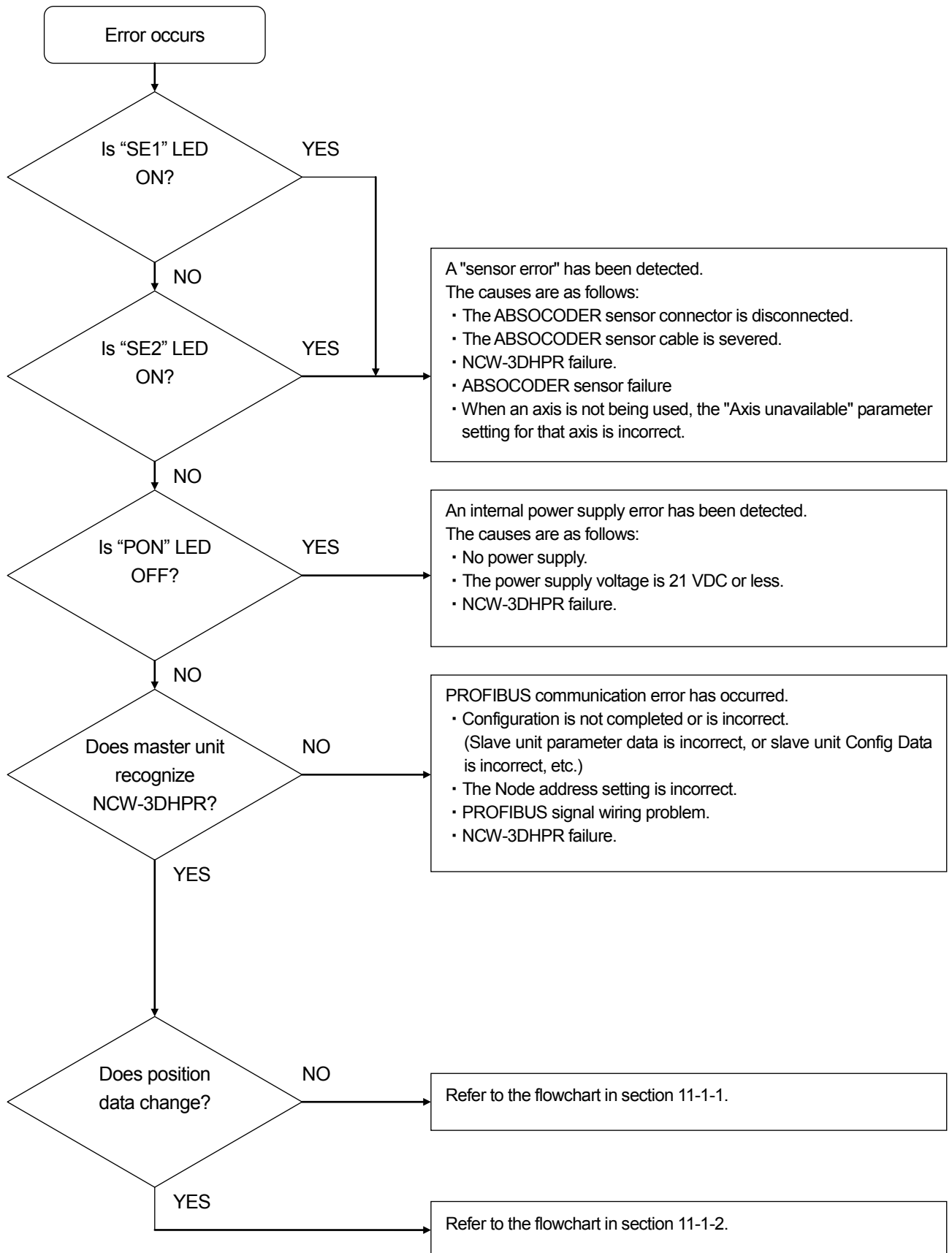

11-1-1. Flowchart when Position Data doesn't Change

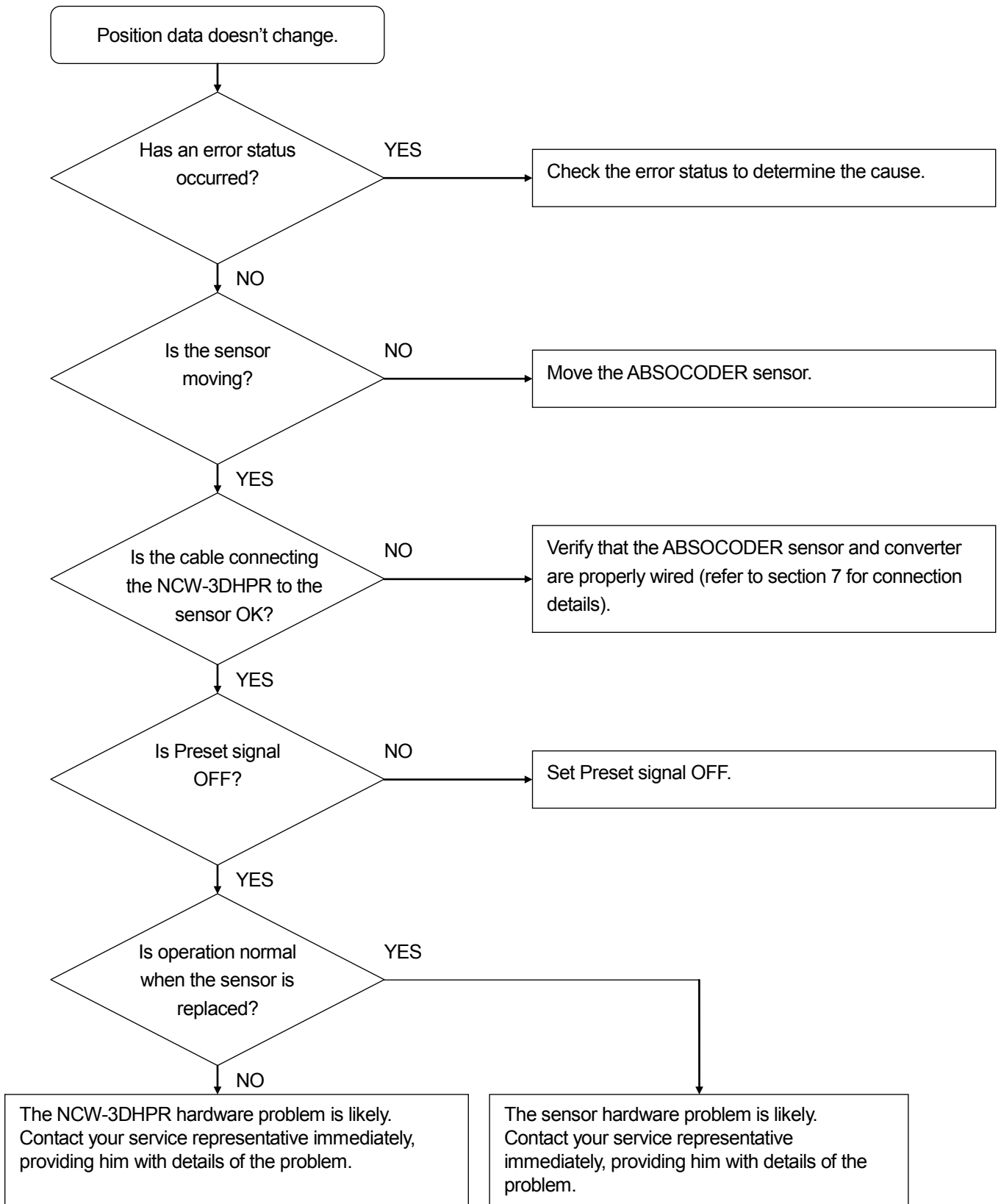

11-1-2. Flowchart when Position Data is not Read.

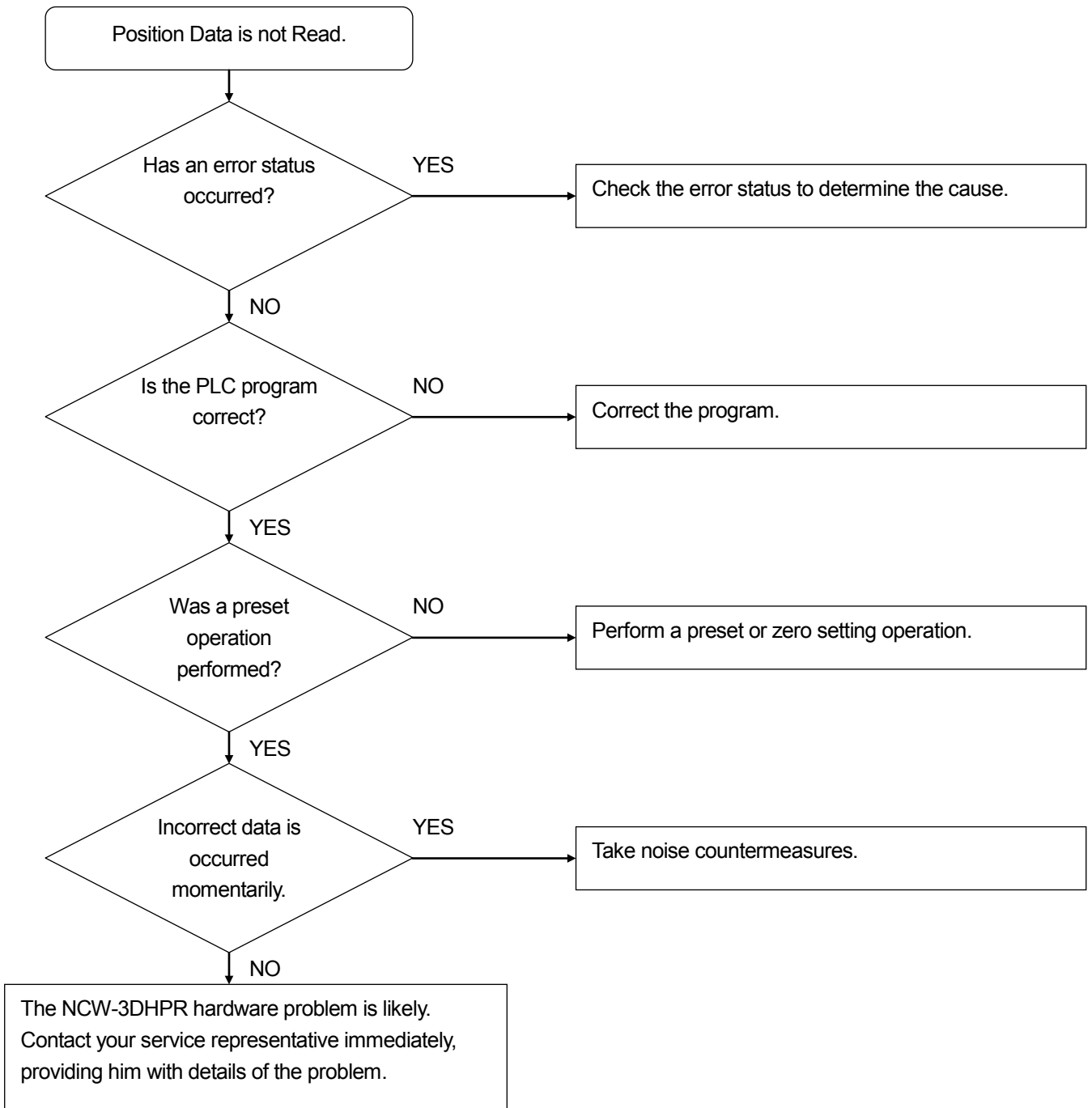

-MEMO-

11-2. ABSOCODER Sensor Check List

● Applicable ABSOCODER sensor models

MRE-32SP061, MRE-32SP074, MRE-32SP097, MRE-32SP101

MRE-G[]SP061, MRE-G[]SP074, MRE-G[]SP097, MRE-G[]SP101

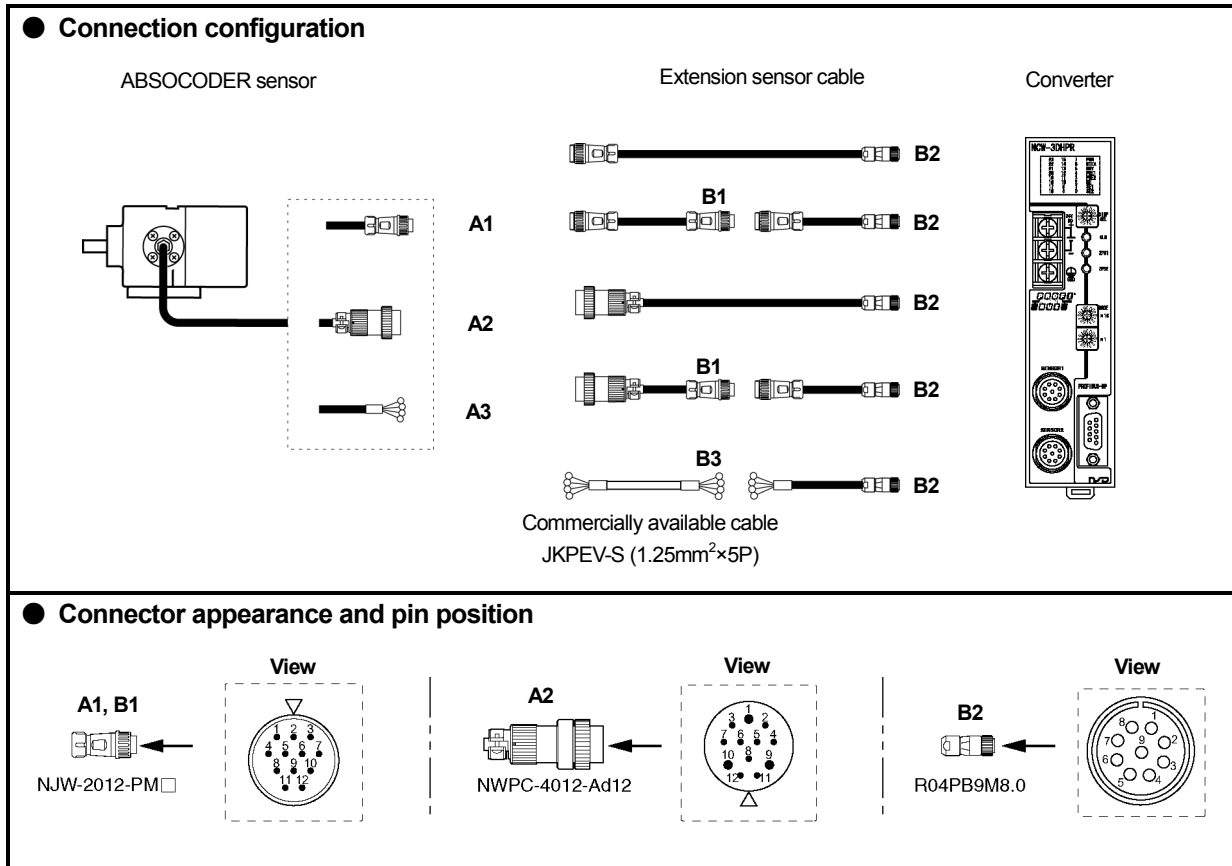

● Connector pin position and standard coil resistance ranges (at 25°C)

Check position						Signal names	Standard coil resistance [Ω]	
A1, A2, A3, B1		B2		B3			MRE-32SP061	MRE-32SP074, 097, 101 MRE-G[]SP061,074,097,101
Pin No.	Wiring color	Pin No.	Wiring color	Wire No. (pair)	Wiring color			
1	Brown	1	Brown	1	White	SIN+	92 to 102	82 to 90
2	Red	2	Red		Black	SIN-		
3	Orange	3	Orange	2	White	-COS+	92 to 102	82 to 90
4	Yellow	4	Yellow		Black	-COS-		
5	Green	5	Green	3	White	OUT1+	10 to 20	15 to 27
6	Blue	6	Blue		Black	OUT1-		
7	Violet	7	Violet	4	White	OUT2+	15 to 25	15 to 27
8	Gray	8	Gray		Black	OUT2-		
9	-	-	-	5	White	-		
10	-	-	-		Black	-		
11	Shield	9	Shield	-	Shield	Shield		
12	-	-	-	-	-	-		

The above standard coil resistance ranges are referential data to assist wiring disconnection diagnosis and are not product specification values. There may be no wiring disconnection even when the resistance measurement is out of the standard resistance range.

● **Circuit resistance check**

[Measurement method]

Measure resistance at Point A or B using a circuit tester or other appropriate device.

Have Point A connected to measure at Point B.

If the connector is off, identify the line by the wiring color.

[Check details]

Refer to the previous page for the connector pin number.

Check position	Criterion	Check position	Criterion
Between brown and red	The measured value should be in the range of the standard coil resistance. *1	Between brown and orange, green, violet, shield	∞
Between orange and yellow		Between orange and green, violet, shield	
Between green and blue		Between green, violet and shield	
Between violet and gray		Between violet and shield	
		Between frame and each wire or shield	

*1: If a check is done at Point B, the measurement value will be [Standard coil resistance + extension sensor cable resistance].

Extension sensor cable resistance value

The resistance value of the NSD special cable is 0.2Ω/m (loop resistance).

The resistance value of the JKPEV-S cable is 0.034Ω/m (loop resistance).

Consider resistance variations due to temperature, which, relative to the standard temperature (25°C), increases 0.4% when the temperature rises 1°C and decreases 0.4% when the temperature falls 1°C.

● **Insulation check**

[Measurement method]

Measure using a 500 VDC insulation tester.

[Check details]

Refer to the previous page for the connector pin number.

Check position	Criterion
Between brown and orange, green, violet, shield	10MΩ or more
Between orange and green, violet, shield	
Between green, violet and shield	
Between violet and shield	
Between frame and each wire or shield	

 **Note**

1. Make sure to disconnect the ABSOCODER sensor from the converter before carrying out insulation checks.
2. If there is a risk that energization may cause damages to the electronic circuits in and around the machine, remove the ABSOCODER sensor from the machine.
3. After completing the checks, short-circuit between the pins to discharge remaining voltage before connecting the ABSOCODER sensor to the converter.

12. CE MARKING

This product conforms to the EMC Directive.

12-1. EMC Directives

It is necessary to do CE marking in the customer's responsibility in the state of a final product.
Confirm EMC compliance of the machine and the entire device by customer because EMC changes configuration of the control panel, wiring, and layout.

12-2. EMC Directive and Standards

EMC consists of emission and immunity items.
It conforms to Table (see below) of EMC standards and Testing.

Class	Standard No.	Standard Name
Emission (EMI)	EN61000-6-4	Generic standards. Emission standard for industrial environments
Immunity (EMS)	EN61000-6-2	Generic standards. Immunity standard for industrial environments
	EN61000-4-2	Electrostatic Discharge
	EN61000-4-3	Radiated, Radio frequency, Electromagnetic Field
	EN61000-4-4	Electrical Fast Transient / Burst
	EN61000-4-5	Surge Immunity
	EN61000-4-6	Conducted Disturbances, Induced by Radio-Frequency Fields
	EN61000-4-8	Power Frequency Magnetic Field

12-3. Low Voltage Directive

This product doesn't apply to low-voltage directive for the equipment of 24VDC power supply.

12-4. Measures for EMC Compliance

Describes measures for EMC compliance when testing the compatibility verification.

● Communication cable for PROFIBUS-DP

The communication cable for PROFIBUS-DP was covered with the shielded zippertubing, and the shield was grounded.

Zippertubing

Model	Manufacturer
MTFS 20 ϕ	ZIPPERTUBING (JAPAN), LTD.

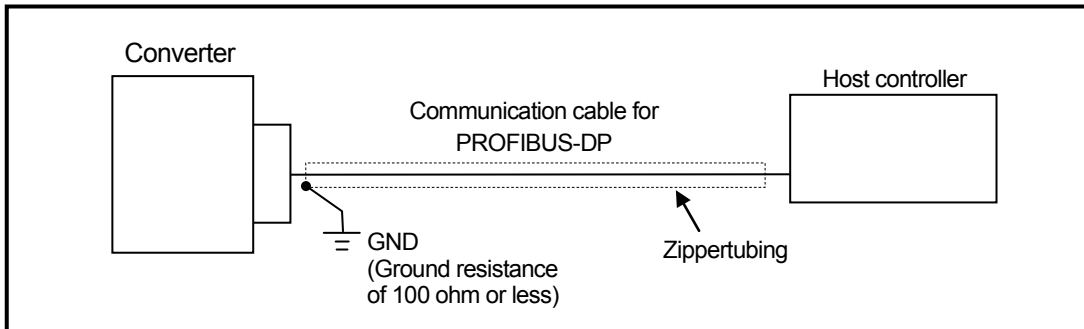

12-5. Restrictions

● Sensor cable

If a 30m or longer sensor cable is to be used, pass the sensor cable through a metal duct or cover the sensor cable with the shielded zippertubing and ground the tube shield.

Zippertubing

Model	Manufacturer
MTFS 20 ϕ	ZIPPERTUBING (JAPAN), LTD.

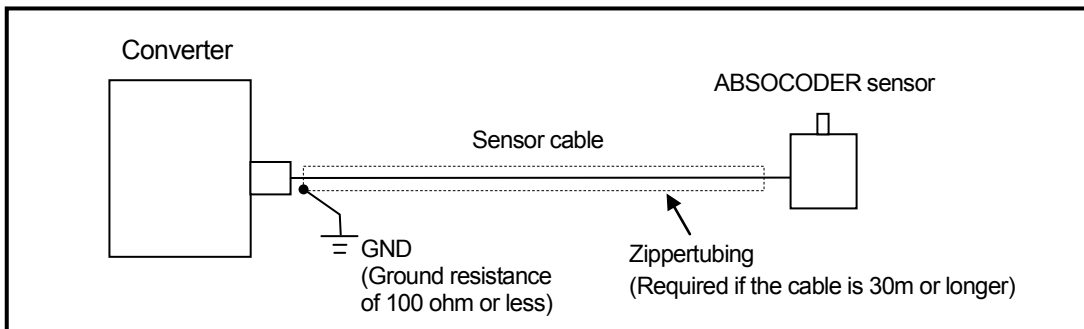

[Reference]

It might be improved when the clamp filter is installed to the power supply or sensor cable when it operates faultily by the influence from the peripheral devices.

Clamp Filter

Mounting location	Clamp filter model	Manufacturer
- Power supply cable - Sensor cable	ZCAT2032-0930 (inner dimensions: ϕ 9)	TDK



NSD Group

Manufacturer

NSD Corporation 3-31-28, OSU, NAKA-KU, NAGOYA, JAPAN 460-8302

Distributor

NSD Trading Corporation 3-31-23, OSU, NAKA-KU, NAGOYA, JAPAN 460-8302

Phone: +81-52-261-2352 Facsimile: +81-52-252-0522

URL: www.nsdcorp.com E-mail: foreign@nsdcorp.com

Copyright©2020 NSD Corporation All rights reserved.