



ZEF005350604

For Iron and Steel Industry

Abycoder®

ABSOCODER CONVERTER

NCV-220HSSILC

Specifications & Instruction Manual

Applicable sensor: CYLNUC cylinder

VLS-12.8PRA28

VLS-12.8MHP28

IRS-51.2P

IRS-32.8P



GENERAL SAFETY RULES



(Please read this safety guide carefully before operation)

Thank you very much for purchasing our product. Before operating this product, be sure to carefully read this manual so that you may fully understand the product, safety instructions and precautions.

- Please submit this manual to the operators actually involved in operation.
- Please keep this manual in a handy place.



Signal Words

Safety precautions in this guide are classified into DANGER and CAUTION.

Symbol	Meaning
 DANGER	Incorrect handling may cause a hazardous situation that will result in death or serious injury.
 CAUTION	Incorrect handling may cause a hazardous situation that will result in moderate injury or physical damage.

Instructions accompanied by a symbol  may also result in serious damage or injury. Be sure to follow the all instructions accompanied by the symbol.

Graphic Symbols







Symbol	Meaning
	Indicates prohibited items.
	Indicates items that must be performed to.



Application Limitation

This product is not designed to be used under any situation affecting human life. When you are considering to use this product for special purposes such as medical equipment, aerospace equipment, nuclear power control systems, traffic systems, and etc., please consult with NSD.



This product is designed to be used under the industrial environments categorized in Class A device. The supplier and user may be required to take appropriate measures.

1. Handling Precautions



 DANGER	
	- Do not touch components inside of the controller; otherwise, it will cause electric shock.
	- Do not damage the cable by applying excessive load, placing heavy objects on it, or clamping; otherwise, it will cause electric shock or fire.
	- Turn the power supply OFF before wiring, transporting, and inspecting the controller; otherwise, it may cause electric shock.
	- Provide an external safety circuit so that the entire system functions safely even when the controller is faulty.
	- Connect the grounding terminal of the controller; otherwise, it may cause electric shock or malfunction.

 CAUTION	
	- Do not use the controller in the following places; water splashes, the atmosphere of the corrosion, the atmosphere of the flammable vapor, and the side of the combustibility. Doing so may result in fire or the controller may become faulty.
	- Be sure to use the controller and the ABSOCODER sensor in the environment designated by the general specifications in the manual. Failure to do so may result in electric shock, fire, malfunction or unit failure. - Be sure to use the specified combination of the ABSOCODER sensor, controller and sensor cable; otherwise, it may cause fire or controller malfunction.



2. Storage

 CAUTION	
	- Do not store the controller in a place exposed to water, or toxic gas and liquid.
	- Be sure to store the controller in designed temperature and humidity range, and do not exposed to direct sunlight. - Be sure to consult with NSD when the controller is stored for long periods.



3. Transport



 CAUTION	
	- Do not hold the cable or shaft of ABSOCODER sensor during transport; otherwise, it will cause injury or controller malfunction.

4. Installation



 CAUTION	
	- Do not step on the ABSOCODER sensor or place heavy objects on the controller; otherwise, it will cause injury. - Do not block the exhaust port or allow any foreign matter to enter the controller; otherwise, it will cause fire or unit failure.
	- Be sure to secure the controller and ABSOCODER sensor with the provided brackets; otherwise, it may cause malfunction, injury, or drop. - Be sure to secure the specified distance between the main body and the control panel or other equipments; otherwise, it may cause malfunction.

5. Wiring



 DANGER	
	- Be sure to secure the terminal block firmly; otherwise, it may have risk of fire. - Be sure to mount the terminal cover provided with the controller, before supplying the power, starting operation after the installation, and wiring; otherwise, it may cause electric shock.

 CAUTION	
	- Be sure to keep the sensor cable, control cable, and communication cable at least 300 mm away from the main circuit and power line; otherwise it may cause injury or malfunction. - Be sure to connect all cables correctly; otherwise, it may cause injury or controller malfunction. - Be sure to firmly connect the external I/O connectors and sensor connectors; otherwise, it may cause incorrect inputs and outputs or injury.



6. Operation

 CAUTION	
	- Do not change the controller's function switch settings during the operation; otherwise, it will cause injury. - Do not approach the machine after instantaneous power failure has been recovered. Doing so may result in injury if the machine starts abruptly, it will cause injury.
	- Be sure to check that the power supply specifications are correct; otherwise, it may caused controller failure. - Be sure to provide an external emergency stop circuit so that operation can be stopped with power supply terminated immediately. - Be sure to conduct independent trial runs for the controller before mounting the controller to the machine; otherwise, it may cause injury. - When an error occur, be sure to eliminate the cause, ensure safety, and reset the error before restarting operation; otherwise, it may cause injury.

7. Maintenance And Inspection

 CAUTION	
	- Do not disassemble, remodel, or repair the unit; otherwise, it will cause electric shock, fire, and unit malfunction.
	- The capacitor of the power line deteriorates through prolonged use. We recommended that the capacitor be replaced every five years to prevent secondary damage.

8. Disposal

 CAUTION	
	- Be sure to handle the controller as industrial waste while disposing of it.

REVISION HISTORY

The Document No. appears at the upper right of this manual's cover page.

Document No.	Date	Revision Description
ZEF005350600	4, Jun., 2013	1st Edition Japanese document: ZEF005350500
ZEF005350601	2, Mar., 2016	2nd Edition Japanese document: ZEF005350501
ZEF005350602	17, Jan., 2017	3rd Edition Japanese document: ZEF005350502
ZEF005350603	19, Jul., 2019	4th Edition Japanese document: ZEF005350503
ZEF005350604	25, Dec., 2020	5th Edition Japanese document: ZEF005350504

CONTENTS

1. OVERVIEW	1
1-1. Features.....	1
1-2. Limitations.....	2
2. MODEL SELECTION WHEN ORDERING	4
3. SPECIFICATIONS	6
3-1. Converter Specifications	6
3-1-1. General specification.....	6
3-1-2. Performance specification.....	6
3-1-3. Input / output specification	7
3-1-4. SSI connector pin arrangement	8
3-1-5. SSI communication specification	9
3-1-6. SSI communication circuit diagram.....	9
3-2. ABSOCODER Sensor Specifications.....	10
3-3. Extension Sensor Cable Specification	14
4. DIMENSIONS	15
4-1. Converter Dimension	15
4-2. ABSOCODER Sensor Dimensions.....	16
4-3. Extension Sensor Cable Dimensions	20
5. CHECKING THE CONTENTS OF THE SHIPPING CASE	22
6. INSTALLATION	23
6-1. Converter Installation Conditions and Precautions.....	23
6-2. ABSOCODER Sensor Installation Conditions and Precautions	24
7. WIRING	25
7-1. Connection between Converter and ABSOCODER Sensor.....	25
7-1-1. Connection configure example of the sensor cable	26
7-2. Power Supply Connection.....	31
8. NOMENCLATURE	32
8-1. Part Identification	32
8-2. Function and Name of Display and Setting Area	33
9. OPERATION	36
9-1. Operation Sequence	36
9-2. SSI Communication Protocol	37
9-3. SSI Communication Timing Chart.....	37
9-4. Error Clear Input (CLR).....	38
9-5. Zero Point Setting Input (ZPS1, ZPS2).....	38
9-6. System Ready Signal Output (NOR1, NOR2)	39
10. INSPECTION	40
11. TROUBLESHOOTING	41
11-1. Display and Countermeasure when an Error Occurred	41
11-2. Error Clear Method.....	41
11-3. ABSOCODER Sensor Check List	42
11-3-1. CYLNUC Cylinder	42
11-3-2. Inrodsensor	46
11-3-3. Rod sensor	48

12. CE MARKING	50
12-1. EMC Directives	50
12-2. EMC Directive and Standards.....	50
12-3. Low Voltage Directive	50
12-4. Restrictions	51

1. OVERVIEW

NCV-220HSSI is the ABSOCODER converter which is compatible with SSI (Synchronized Serial Interface).

This converter can detect the machine position by combining the ABSOCODER sensor.

The host controller can read this position data in SSI signals.

1-1. Features

- Superior durability
NSD's original ABSOCODER is used as the position sensor which features a no-contact construction for excellent durability. This sensor offers problem-free operation, even in environments where it is exposed to vibration, impact shocks, extreme temperatures, oil, and dust.
- Compact design
The unit's outside dimensions (39(W) x 155(H) x 93(D)) were miniaturized. DIN rail can be used, so mounting is much easier.
- Less wiring
The wiring can reduce by using the SSI communication.
- Two axes ABSOCODER sensor can connect
The machine positions for two axes can be detected by one converter. The space-saving in the control panel can be conducted.
- Rotating direction setting function
The increase direction of the position data can be set by changing the setting switch.
- Output code switch function
The converter can switch codes (gray / binary) by changing the setting switch.
- Zero point setting function
The zero point can set in desired machine position by pressing the zero point setting button on the panel or turning the zero point signal ON from external input. The converter has a setting button and input signal for two axes, so the zero point setting is available for each axis.
- Error detection function
An error status can be checked by the monitor LED of the converter when an error occurs. The PLC and host controller can also check the error, because the converter has a system ready signal.
- Applicable with JKPEV-S cable
A commercially available cable (JKPEV-S 1.25mm² x 5P) can be used between the converter and ABSOCODER sensor.
- Compliance with CE standards
The converter complies with CE (EMC Directive) standards.

1-2. Limitations



Important

Cautions concerning power-off and error occurrence

If the sensor moves while the converter power is OFF or when an error is present, it mightn't detect accurate machine positions thereafter.

The zero position setting should be done after turning ON the power supply or clearing the error.

- MEMO -





2. MODEL SELECTION WHEN ORDERING

The following figure indicates the connection configuration of NCV-220HSSI.

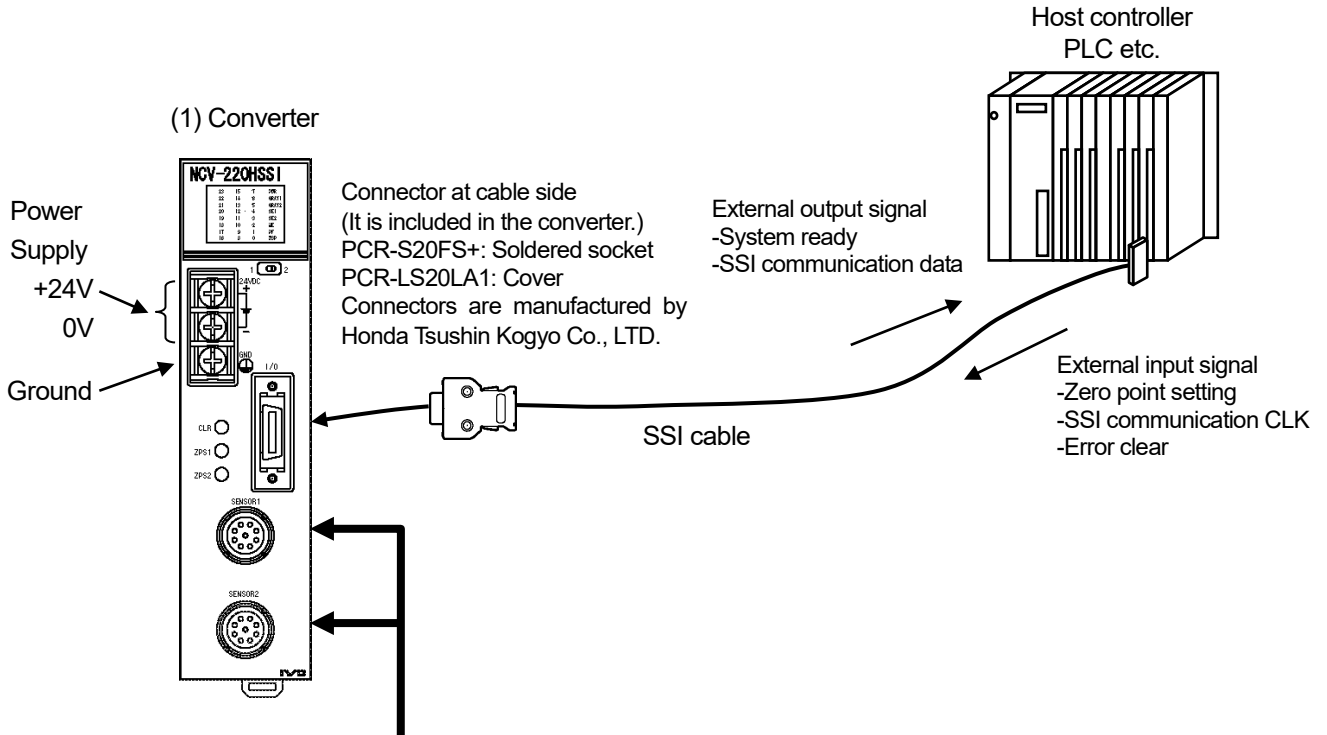
Before ordering, refer to the connection configuration and model list. Please prepare by customer except 1 to 3 in the connection configuration.

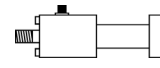
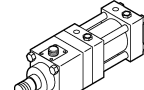
● Connection configuration

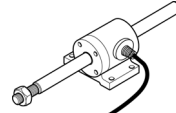

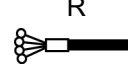
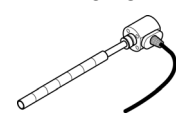
(3) Extension sensor cable	(2) ABSOCODER sensor	
<p>In the case of using the NSD special cable</p> <p>4P-S/RBT/URT-0140-[L]</p> <p>[01] [40]</p> <p>4P-S/RBT/URT-0144-[L] 4P-S/RBT/URT/HRT-4340-[L]</p> <p>[01] [44] [43] [40]</p> <p>4P-S/RBT/URT-0190-[L] 4P-S/RBT/URT/HRT-9040-[L]</p> <p>[01] [90] [90] [40]</p>	<p>No cable</p>  <p>(SCM, SCJ, SCMJ, SCJJ)</p>	<p>CYLNUC Cylinder CYLNUC Mark II Cylinder</p> 
<p>4P-S/RBT/URT-0144-[L]</p> <p>[01] [44]</p> <p>4P-S/RBT/URT-0144-[L] 4P-S/RBT/URT/HRT-4344-[L]</p> <p>[01] [44] [43] [44]</p> <p>4P-S/RBT/URT-0190-[L] 4P-S/RBT/URT/HRT-9090-[L]</p> <p>[01] [90] [90] [90]</p>	<p>Connector type</p> <p>B</p>  <p>R</p> 	<p>VLS-12.8PRA28 VLS-12.8MHP28</p> 
<p>In the case of using the commercially available cable</p> <p>4P-S/RBT/URT-0155-[L] JKPEV-S(1.25mm² x5P)</p> <p>[01] [55] NWPC-4012-Ad14 NWPC-4012-P14</p> <p>[27] [26]</p> <p>4P-S/RBT/URT-0190-[L] JKPEV-S(1.25mm² x5P)</p> <p>[01] [90]</p>	<p>P</p>  <p>R</p> 	<p>IRS-51.2P IRS-32.8P</p> 

● Model List

◆ Converter

No.	Model	Description
(1)	NCV-220HSSILC	For CYLNUC Cylinder and Linear type ABSOCODER sensor

◆ ABSOCODER sensor

No.	Item	Model	Description
(2)	ABSOCODER sensor (CYLNUC Cylinder)	SCM	Resolution: 1.5625μm
		SCJ	
		SCMJ	
		SCJJ	
		SCHH	
		SCAH	
		CSAH	
	ABSOCODER sensor (CYLNUC Mark II Cylinder)	M I I M	Built-in Inrodsensor Resolution: 6.25μm
		M I I J	
		M I I M J	
		M I I J J	
	ABSOCODER sensor (Linear type)	VLS-12.8PRA28	Rod sensor, resolution: 1.5625μm
		VLS-12.8MHP28	
IRS-51.2P		Inrodsensor, resolution: 6.25μm	
IRS-32.8P		Inrodsensor, resolution: 4μm	

For more details of the ABSOCODER sensor, contact your NSD sales representatives.

◆ Extension sensor cable

No.	Model	Description
(3)	4P-[1]-[2][3]-[L]	<p>[1]···Cable type S: Standard cable RBT: Robotic cable URT: Semi-heat-resistant robotic cable HRT: Heat-resistant robotic cable</p> <p>[2]···Connector (Converter side) 01: Connector for connecting to a converter (R04-PB9M8.0A) 43: Standard connector (NJW-2012-PM8) 90: Crimping terminals (R-1.25-4)</p> <p>[3]···Connector (Sensor side) 40: Connector for directly connecting to a sensor (NJW-2012-PF8) 44: Standard connector (NJW-2012-AdF8) 55: Large connector (NWPC-4012-P12) 90: Crimping terminals (R-1.25-4)</p> <p>[L]···Cable length (m) Contact your NSD representative for the cable length.</p>
	JKPEV-S(1.25mm ² ×5P)	Commercially available cable

3. SPECIFICATIONS

3-1. Converter Specifications

3-1-1. General specification

Items	Specifications
Power supply voltage	24VDC±10% (including ripple)
Power consumption	10W or less
Insulation resistance	20 M-Ohms or more between external DC power terminals and ground (by 500 VDC insulation resistance tester)
Withstand voltage	500 VAC, 60Hz for 1 minute between external DC power terminals and ground
Vibration resistance	20m/s ² 10 to 500Hz, 10cycles of 5 minutes in 3 directions, conforms to JIS C 0040 standard
Ambient operating temperature	0 to +55°C (No freezing)
Ambient operating humidity	20 to 90 %RH (No condensation)
Ambient operating environment	Free from corrosive gases and excessive dust
Ambient storage temperature	-25 to +70°C
Grounding	Must be securely grounded (ground resistance of 100 ohm or less)
Construction	Book-shelf type within enclosure, DIN rail mountable
Outside dimension (mm)	39(W) x 155(H) x 93(D) Refer to dimensions for details.
Mass	Approx. 0.4kg

3-1-2. Performance specification

Items	Specifications		
	CYLNUC Cylinder VLS-12.8PRA28 VLS-12.8MHP28	CYLNUC Mark II Cylinder IRS-51.2P	IRS-32.8P
Resolution	1.5625µm (12.8mm/8192)	6.25µm (51.2mm/8192)	4µm (32.8mm/8192)
Total number of divisions	Standard pitch x number of pitches (8192 divisions (2 ¹³) x max. 2048 pitches)		
Position detection format	Semi-absolute format		
Communication interface	SSI (Synchronized Serial Interface)		
Number of communication channels	2ch		
Output code	Binary or gray code (switchable)		
Number of detection axes	2		
Position data sampling time	0.2ms		
Position data increase direction	CW or CCW (switchable)		
Front panel function	Zero point setting, error clear		
Switch (on rear face of product)	Position data increase direction setting (CW / CCW) Output code (binary /gray) Axis-2 error detection (enable / disable)		
Monitor LED	Display of position data, power supply status, sensor disconnected error, sensor data error, low power supply error, memory error, converter error		
Input signal	Axis-1 zero point setting: 1-point Axis-2 zero point setting: 1-point Error clear signal: 1-point		
Output signal	Axis-1 system ready signal: 1-point Axis-2 system ready signal: 1-point		
Applicable standard	CE Marking (EMC directive)		

3-1-3. Input / output specification

Input		Output	
Items	Specifications	Items	Specifications
Input signals	ZPS1 (axis-1 zero point setting): 1-point ZPS2 (axis-2 zero point setting): 1-point CLR (error clear): 1-point	Output signals	NOR1 (axis-1 system ready signal): 1-point NOR2 (axis-2 system ready signal): 1-point
Input circuit	DC input, photo-coupler isolation	Output circuit	Photo-coupler isolation
Input logic	Negative logic	Output logic	Negative logic
Rated input voltage	24VDC	Rated load voltage	24VDC (30VDC max)
Input current	10mA TYP (24VDC)	Max. load current	100 mA
		Max. voltage drop when ON	1.5V (100mA)

Circuit diagram

Sink connection

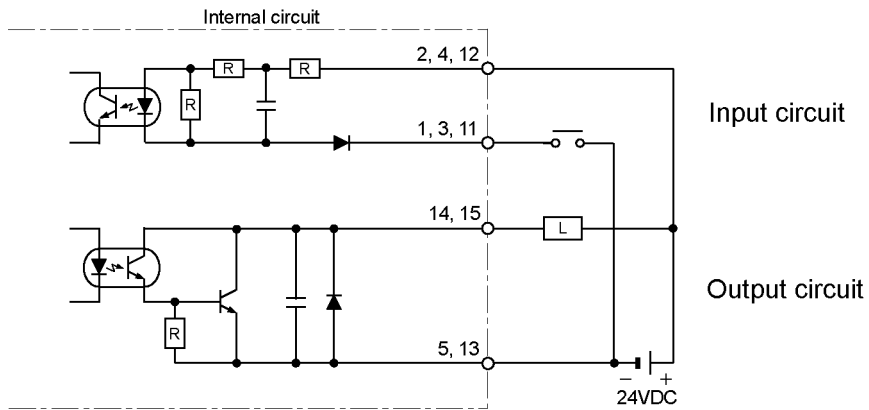

Source connection

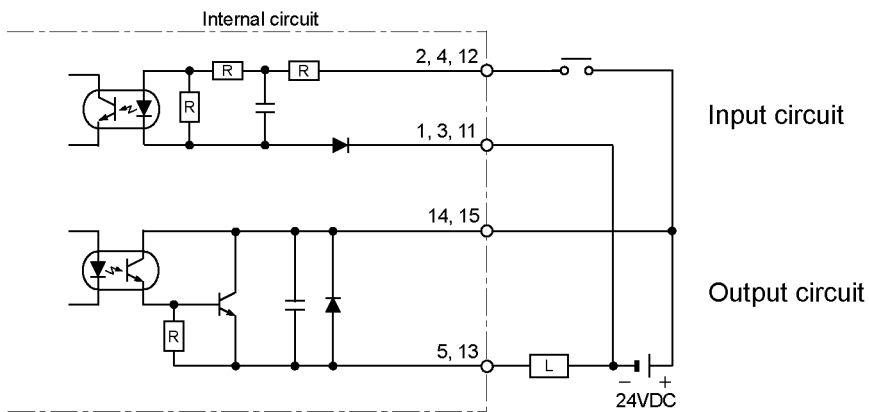

3-1-4. SSI connector pin arrangement

Pin No.	Signal name	Pin No.	Signal name	Connector dimension
1	ZPS2-	11	ZPS1-	<p>Shows the pin arrangement as viewed from the soldering terminals side.</p>
2	ZPS2+	12	ZPS1+	
3	CLR-	13	NOR1-	
4	CLR+	14	NOR1+	
5	NOR2-	15	NOR2+	
6	SG (0V)	16	SG (0V)	
7	CLK2-	17	DATA2-	
8	CLK2+	18	DATA2+	
9	CLK1-	19	DATA1-	
10	CLK1+	20	DATA1+	

● Accessory

Connector model: PCR-S20FS+ / PCR-LS20LA1 (Manufacturer: HONDA TSUSHIN KOGYO CO., LTD)

● Usage cable

Use the cable for RS-422 / RS-485 (twist-pair cable with shield).

Sheath diameter: Max ϕ 10 or less Wire size: 0.2mm² (AWG24)

Reference

We conduct the operation check with using the following cable.

CO-SPEV-SB (A) 10P x 0.2SQ LF (Manufacturer: Hitachi Cable, Ltd.)

3-1-5. SSI communication specification

Items	Specifications
Interface	SSI (Synchronized Serial Interface)
Communication format	RS-422 standard
Numbers of channels	2 channels (per sensor axis)
Communication signal	DATA+, DATA-, CLK+, CLK-
Code	Gray / binary
Data length	25-bit
Monoflop time	20 μ s
Transmission speed: cable length	1MHz: 20m, 500kHz: 60m, 250kHz: 160m, 125kHz: 320m

3-1-6. SSI communication circuit diagram

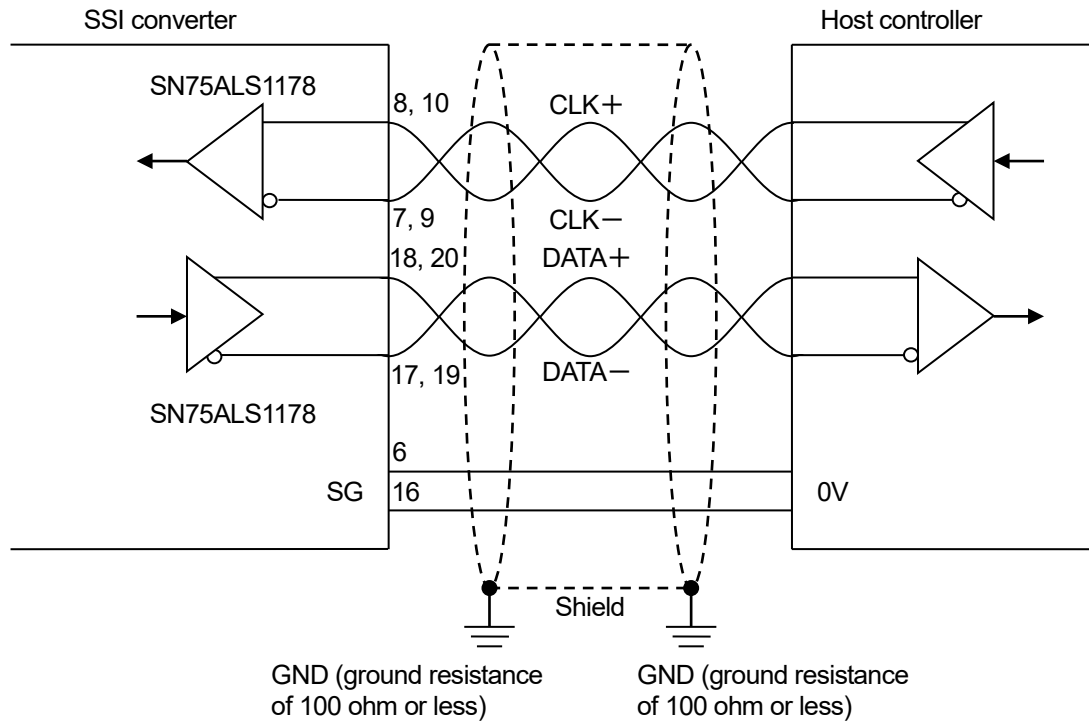

*** Method of shield grounding**

The shield of the cable should be grounded (ground resistance of 100 ohm or less) at both sides of SSI converter and host controller.

3-2. ABSOCODER Sensor Specifications

(1) CYLNUC Cylinder / CYLNUC Mark II Cylinder

Models		CYLNUC cylinder	CYLNUC Mark II Cylinder
		SCM, SCJ, SCMJ, SCJJ SCHH SCAH, CSAH	M I I M, M I I J M I I M J, M I I J J
Absolute detection range		12.8mm (0.5039inch)	51.2mm (2.0157inch)
Resolution		1.5625 μ m (12.8mm/8192)	6.25 μ m (51.2mm/8192)
Max. sensor cable length	Standard cable	4P-S 200m	
	Robotic cable	4P-RBT 100m	
	JKPEV-S cable	JKPEV-S (1.25mm ² × 5P) 200m	

*For more details, contact your NSD representative.

(2) Rod sensor (VLS-12.8PRA28)

Items		Specifications	
Model		VLS-12.8PRA28-[]FA[]	VLS-12.8PRA28-[]LA[]
Max. detection stroke		1200 mm	
Absolute detection range		12.8 mm	
Resolution		1.5625 μ m (12.8mm/8192)	
Linearity error		Max. 0.15 + [stroke (mm)]/2000 mm	
Mass	Head	6.5 + 0.1 x [cable length(m)] kg	
	Rod	1 + 0.0048 x [stroke (mm)] kg	
Sliding resistance		69 N or less (7kgf or less)	
Permissible mechanical speed		1000 mm/s	
Ambient temperature	Operating	-20 to +120°C	
	Storage	-30 to +120°C	
Ambient operating humidity		—	
Vibration resistance		2.0 x 10 ² m/s ² (20G) 200Hz up/down 4h, forward/back/left/right 2h each, conforms to JIS D 1601 standard	
Shock resistance		4.9 x 10 ³ m/s ² (500G) 0.5ms, up/down x 3 times, conforms to JIS C 5026 standard	
Protection rating		IP67, conforms to JEM 1030 standard IP69K, conforms to ISO 20653 standard	
Interconnecting cable		2 · 5 · 10 · 20m	
Max. sensor cable length	Standard cable	4P-S 200m	
	Robotic cable	4P-RBT 100m	
	JKPEV-S cable	JKPEV-S (1.25mm ² × 5P) 200m	
Surface	Head	Electroless nickel plated	Coated (epoxy resin)
	Rod	Hard chromium electro plated	Hard chromium electro plated
Material	Head	Steel	Cast iron
	Rod	Steel	Steel

(3) Rod sensor (VLS-12.8MHP28)

Items		Specifications	
Model		VLS-12.8MHP28-[]FA[]	VLS-12.8MHP28-[]LA[]
Max. detection stroke		1200 mm	
Absolute detection range		12.8 mm	
Resolution		1.5625 μ m(12.8mm/8192)	
Linearity error		Max. 0.15 + [stroke (mm)]/5000 mm	
Mass	Head	6.5 + 0.1 x [cable length(m)] kg	
	Rod	1 + 0.0048 x [stroke (mm)] kg	
Sliding resistance		69 N or less (7kgf or less)	
Permissible mechanical speed		1000 mm/s	
Ambient temperature	Operating	-20 to +120°C	
	Storage	-30 to +120°C	
Ambient operating humidity		—	
Vibration resistance		2.0 x 10 ² m/s ² (20G) 200Hz up/down 4h, forward/back/left/right 2h each, conforms to JIS D 1601 standard	
Shock resistance		4.9 x 10 ³ m/s ² (500G) 0.5ms, up/down x 3 times, conforms to JIS C 5026 standard	
Protection rating		IP67, conforms to JEM 1030 standard IP69K, conforms to ISO 20653 standard	
Interconnecting cable		2 · 5 · 10 · 20m	
Max. sensor cable length	Standard cable	4P-S 200m	
	Robotic cable	4P-RBT 100m	
	JKPEV-S cable	JKPEV-S (1.25mm ² × 5P) 200m	
Surface	Head	Electroless nickel plated	Coated (epoxy resin)
	Rod	Hard chromium electro plated	Hard chromium electro plated
Material	Head	Steel	Cast iron
	Rod	Steel	Steel

(4) Inrodsensor (IRS-51.2P)

Items		Specifications										
Model		IRS-51.2P18 IRS-51.2PA18					IRS-51.2P30 IRS-51.2PA30					
Detection stroke		25.6 to 1024 mm					25.6 to 2048 mm					
Absolute detection range		51.2mm										
Resolution		6.25 μm(51.2mm/8192)										
Linearity error		Max. 0.15 + [stroke (mm)] /5000 mm										
Mass		1.3 + 0.0012 x [stroke (mm)] + 0.1 x [cable length (m)] kg					3.0 + 0.0033 x [stroke (mm)] + 0.1 x [cable length (m)] kg					
Permissible mechanical speed		2000 mm/s										
Ambient temperature	Operating	-20 to +120°C										
	Storage	-30 to +120°C										
Ambient operating humidity		—										
Vibration resistance	Stroke	mm	512	640	768	896	1024	768	896	1152	1408	1664
	Radial	m/s ²	2.0x10 ²	1.5x10 ²	7.8x10 ¹	4.9x10 ¹	2.9x10 ¹	2.0x10 ²	1.5x10 ²	9.8x10 ¹	4.9x10 ¹	2.9x10 ¹
		(G)	(20)	(15)	(8)	(5)	(3)	(20)	(15)	(10)	(5)	(3)
	Max.2.0x10 ² m/s ² (20G) 200Hz 4h, conforms to JIS D 1601 standard											
	Thrust	m/s ² (G)	2.0x10 ² m/s ² (20G) 200Hz 4h, conforms to JIS D 1601 standard									
Shock resistance	Stroke	mm	512	640	768	896	1024	768	896	1152	1408	1664
	Radial	m/s ²	9.8x10 ²	6.9x10 ²	4.9x10 ²	3.9x10 ²	2.9x10 ²	7.8x10 ²	5.9x10 ²	3.9x10 ²	2.9x10 ²	2.0x10 ²
		(G)	(100)	(70)	(50)	(40)	(30)	(80)	(60)	(40)	(30)	(20)
	Max. 9.8 x 10 ² m/s ² (100G) 0.5ms, 3times, confirms to JIS C 5026 standard											
	Thrust	m/s ² (G)	4.9 x 10 ³ m/s ² (500G) 0.5ms, 3times, confirms to JIS C 5026 standard									
Protection rating	Max. operating pressure		IRS-51.2P : 24.5MPa(250kgf/cm ²) IRS-51.2PA: 35.0MPa(357kgf/cm ²)									
	Proof test pressure		IRS-51.2P : 36.8MPa(375kgf/cm ²) IRS-51.2PA : 52.5MPa(536kgf/cm ²)									
	Oil resistance (Detection side)		Mineral oil, water-glycol, water-in-oil emulsion, polyol ester, phosphate ester									
	Waterproof (Flange side)		IP67 conforms to JEM 1030 standard IP69K, conforms to ISO 20653 standard									
Interconnecting cable		5 · 10 · 20m										
Max. sensor cable length	Standard cable		4P-S 200m									
	Robotic cable		4P-RBT 100m									
	JKPEV-S cable		JKPEV-S (1.25mm ² × 5P) 200m									
Surface	Head		Not treated									
	Scale		Not treated									
Material	Head		Stainless									
	Scale		Stainless, Steel, Brass									

(5) Inrodsensor (IRS-32.8P)

Items		Specifications					
Model		IRS-32.8P18, IRS-32.8PA18					
Detection stroke		16.384 to 1015.808 mm					
Absolute detection range		32.768mm					
Resolution		4 μ m(32.768mm/8192)					
Linearity error		Max. 0.1+ [stroke (mm)] /5000 mm					
Mass		1.1 + 0.0012 x [stroke (mm)] + 0.1 x [cable length (m)] kg					
Permissible mechanical speed		2000 mm/s					
Ambient temperature	Operating	-20 to +120°C					
	Storage	-30 to +120°C					
Ambient operating humidity		—					
Vibration resistance	Stroke	mm	507.9	638.9	753.6	884.7	1015.8
	Radial	m/s ²	2.0x10 ²	1.5x10 ²	7.8x10	4.9x10	2.9x10
		(G)	(20)	(15)	(8)	(5)	(3)
	Max.2.0x10 ² m/s ² (20G) 200Hz 4h, conforms to JIS D 1601 standard						
Thrust	m/s ²	2.0x10 ² m/s ² (20G) 200Hz 4h, conforms to JIS D 1601 standard					
	(G)						
Shock resistance	Stroke	mm	507.9	638.9	753.6	884.7	1015.8
	Radial	m/s ²	9.8x10 ²	6.9x10 ²	4.9x10 ²	3.9x10 ²	2.9x10 ²
		(G)	(100)	(70)	(50)	(40)	(30)
	Max. 9.8 x 10 ² m/s ² (100G) 0.5ms, 3times, confirms to JIS C 5026 standard						
Thrust	m/s ²	4.9 x 10 ³ m/s ² (500G) 0.5ms, 3times, confirms to JIS C 5026 standard					
	(G)						
Protection rating	Max. operating pressure	IRS-32.8P18: 24.5MPa(250kgf/cm ²) IRS-32.8PA18: 35.0MPa(357kgf/cm ²)					
	Proof test pressure	IRS-32.8P18: 36.8MPa(375kgf/cm ²) IRS-32.8PA18: 52.5MPa(536kgf/cm ²)					
	Oil resistance (Detection side)	Mineral oil, water-glycol, water-in-oil emulsion, polyol ester, phosphate ester					
	Waterproof (Flange side)	IP67 conforms to JEM 1030 standard IP69K, conforms to ISO 20653 standard					
Interconnecting cable		5 · 10 · 20m					
Max. sensor cable length	Standard cable	4P-S 200m					
	Robotic cable	4P-RBT 100m					
	JKPEV-S cable	JKPEV-S (1.25mm ² x5P) 200m					
Surface	Head	Not treated					
	Scale	Not treated					
Material	Head	Stainless					
	Scale	Stainless, Steel, Brass					

3-3. Extension Sensor Cable Specification

Items	Specifications			
Model code	4P-S	4P-RBT	4P-URT	4P-HRT
Cable type	Standard cable	Robotic cable	Semi heat-resistant robotic cable	Heat-resistant robotic cable
Diameter	$\phi 8$			
Operating temperature range	-5 to +60°C		-5 to +105°C	0 to +150°C
Insulator	Irradiated cross linked foamed polyethylene	ETFE plastic		
Sheath	Polyvinyl chloride mixture		Heat-resistant polyvinyl chloride mixture	Fluoro-rubber
Construction	8-core, 2 pairs without shield + 2 pairs with shield			
Color	Gray	Black		
Advantage	Extensible for long distances	Superior flexibility; ideal for moving place		Heat treatment and flexible; ideal for moving place

[Remark]

Contact your NSD representative when the extension cable combines different types of cables.

4. DIMENSIONS

4-1. Converter Dimension

Units: mm

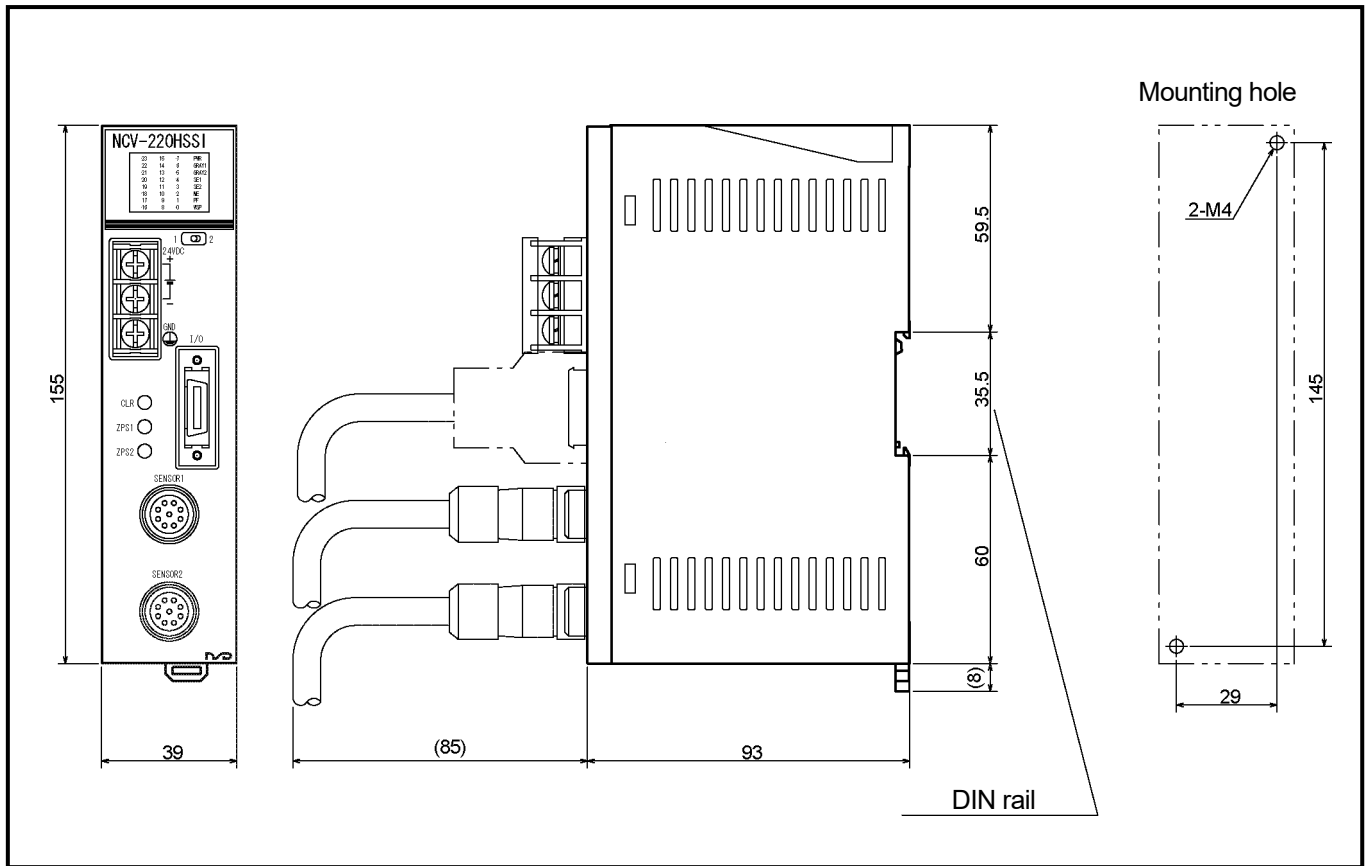

4-2. ABSOCODER Sensor Dimensions

(1) CYLNUC Cylinder / CYLNUC Mark II Cylinder

Contact your NSD representative for details of the dimension.

(2) Rod sensor (VLS-12.8PRA28)

◆VLS-12.8PRA28-[]FA[] (Flange-mount type)

Units: mm

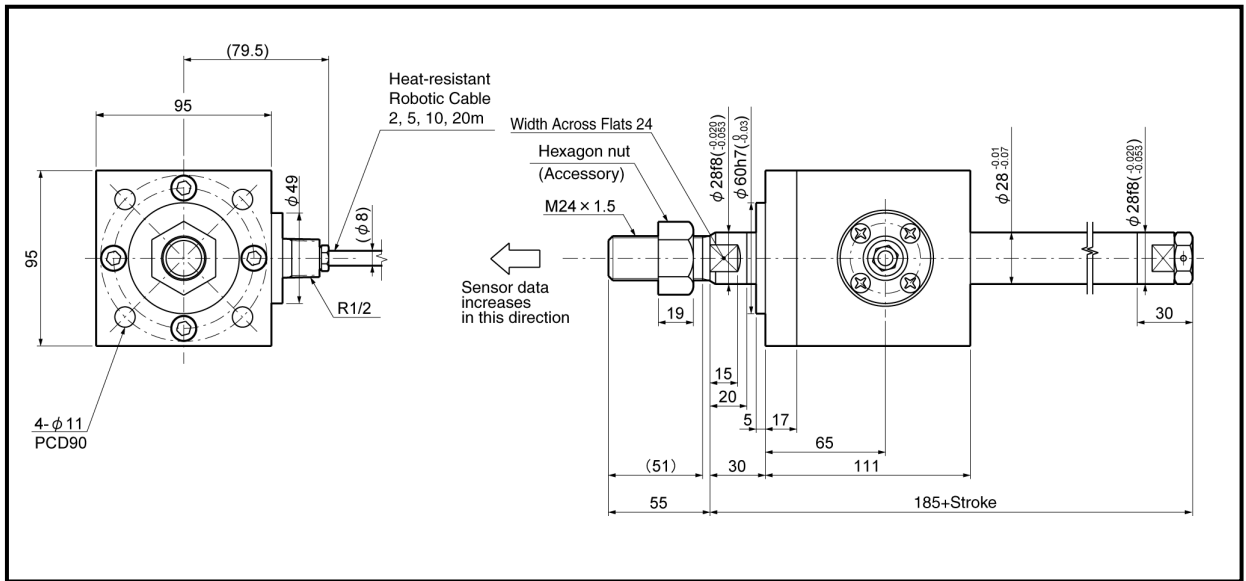

◆VLS-12.8PRA28-[]LA[] (Base-mount type)

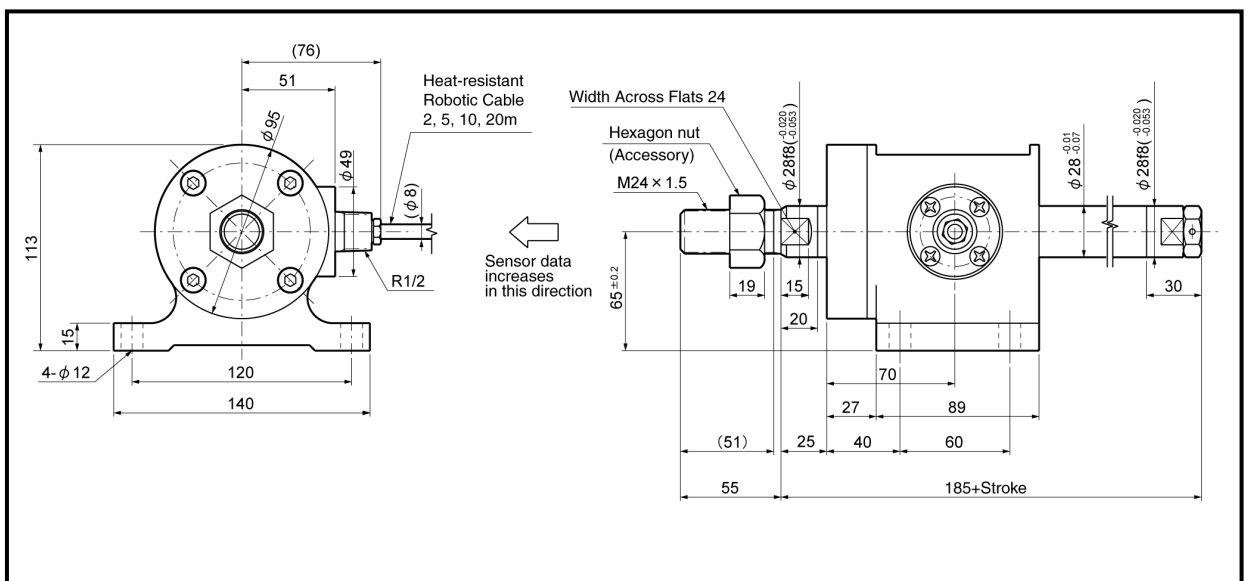

(3) Rod sensor (VLS-12.8MHP28)

◆VLS-12.8MHP28-[]FA[] (Flange-mount type)

Units: mm

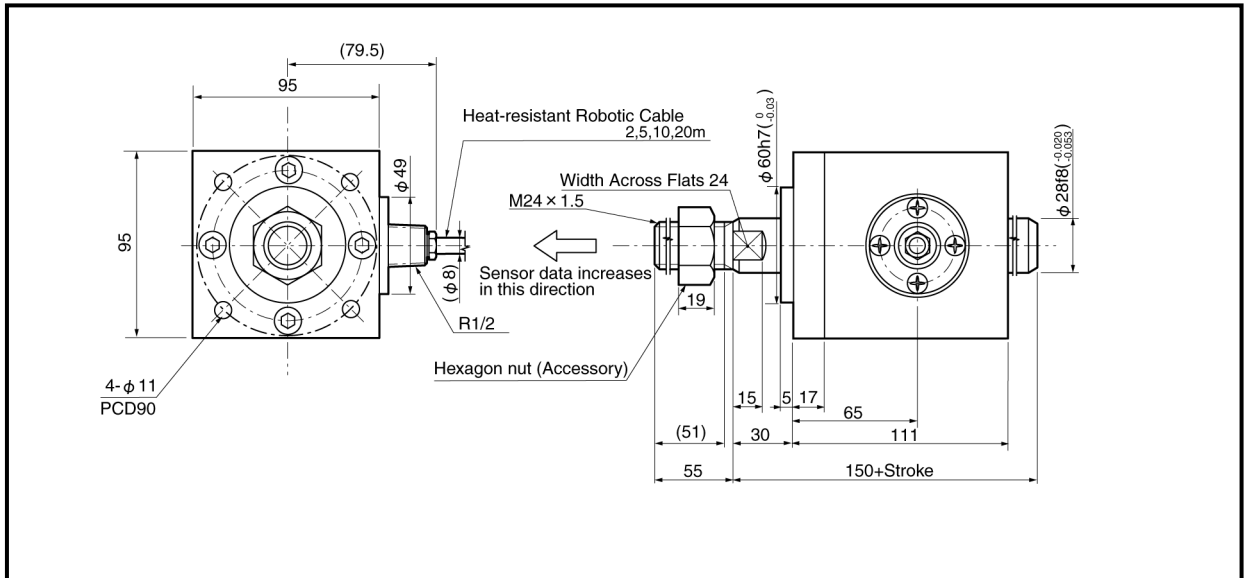

◆VLS-12.8MHP28-[]LA[] (Base-mount type)

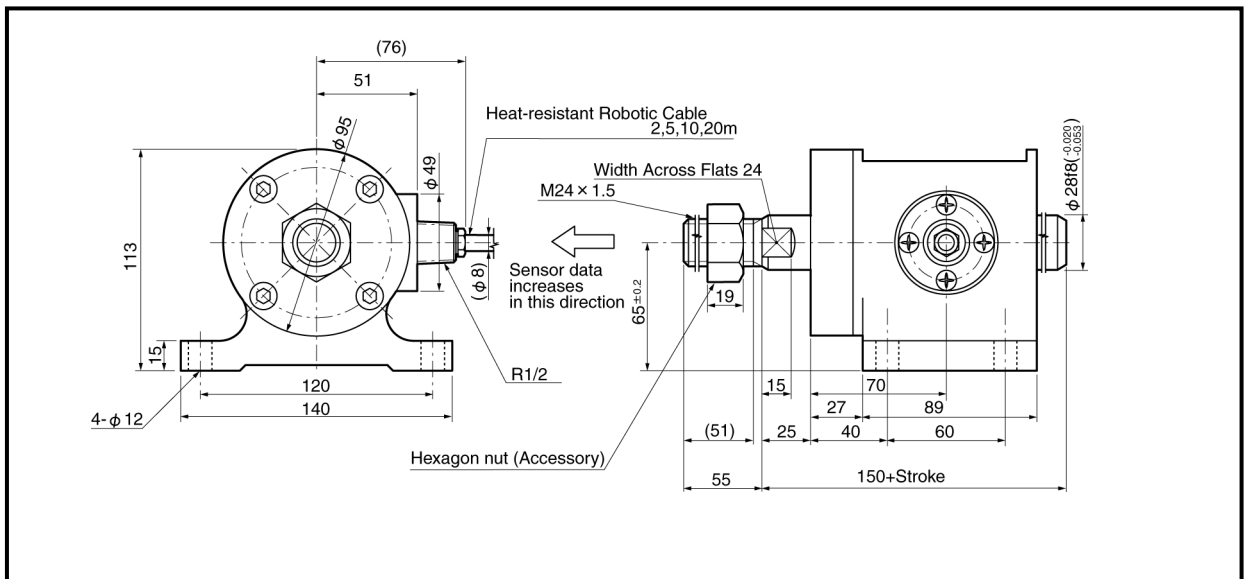

(4) Inrodsensor (IRS-51.2P)

◆ **IRS-51.2P18[], IRS-51.2PA18[]**

Units: mm

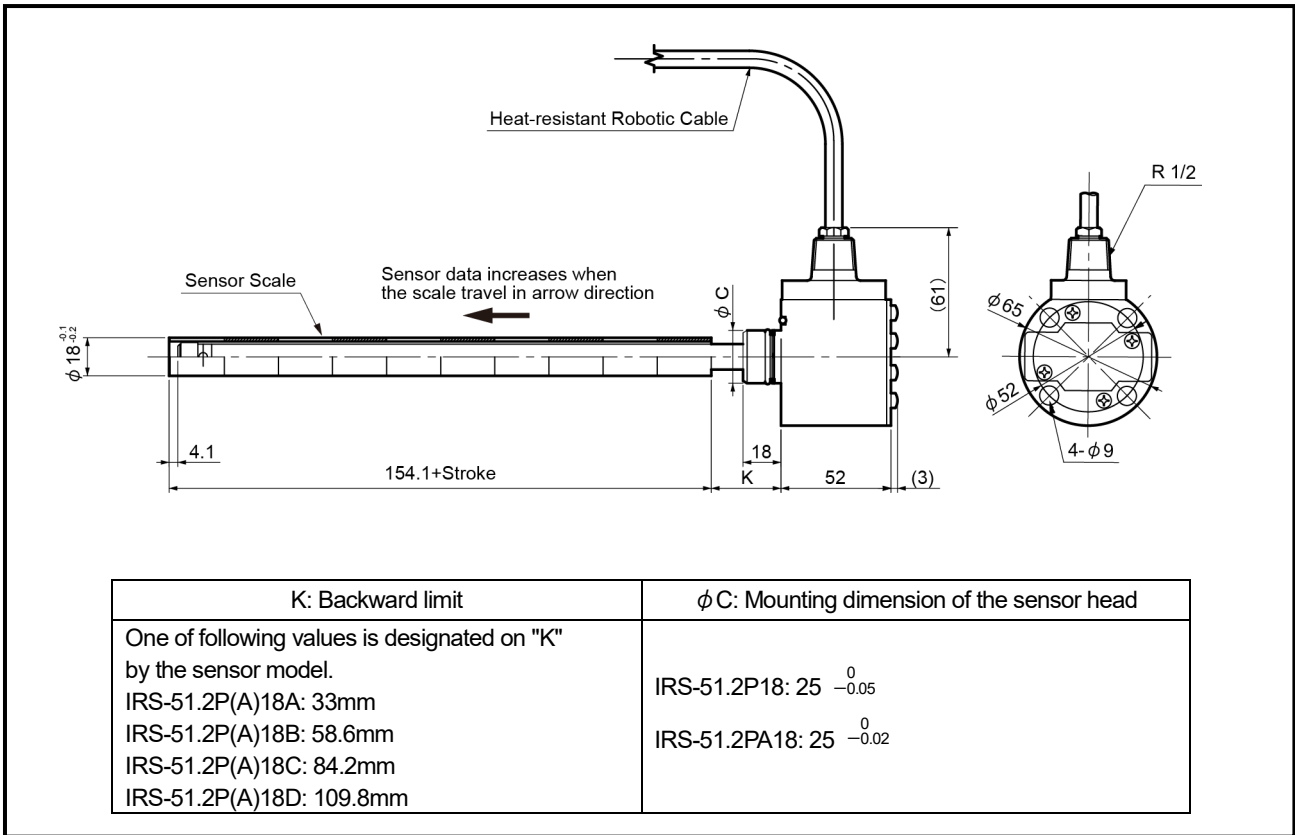

◆ **IRS-51.2P30□, IRS-51.2PA30□**

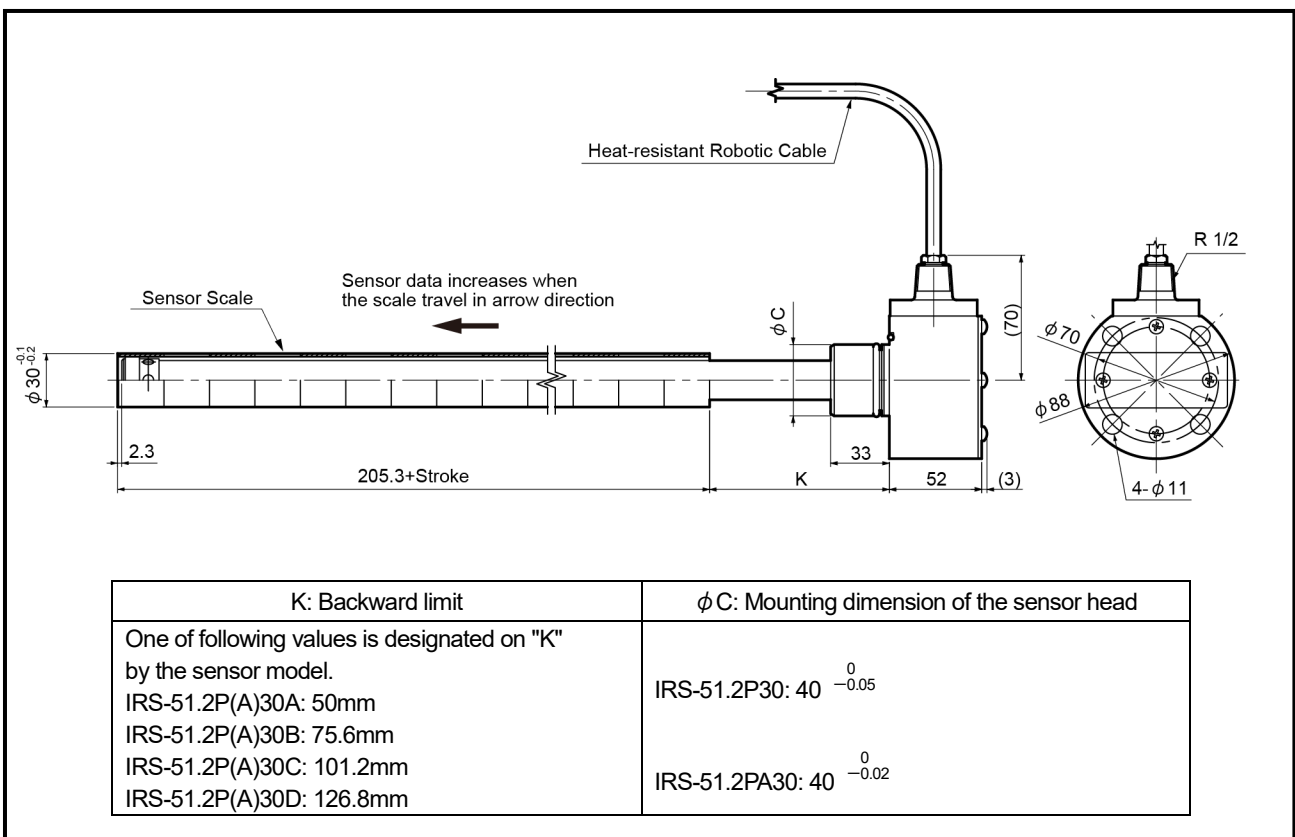

(5) Inrodsensor (IRS-32.8P)

◆ IRS-32.8P18[], IRS-32.8PA18[]

Units: mm

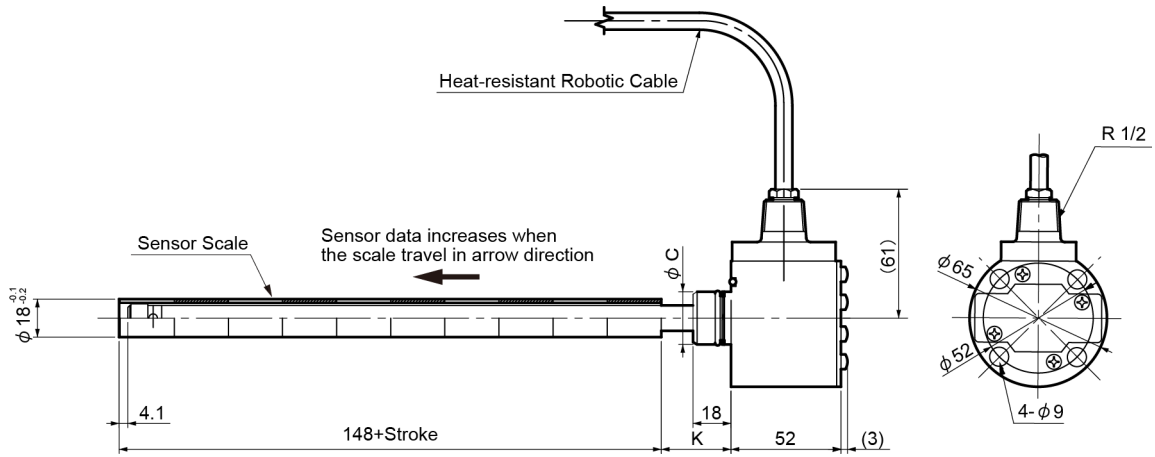

K: Backward limit	ϕC : Mounting dimension of the sensor head
One of following values is designated on "K" by the sensor model.	
IRS-32.8P(A)18A: 33mm	IRS-32.8P18: 25 $_{-0.05}^0$
IRS-32.8P(A)18B: 58.6mm	
IRS-32.8P(A)18C: 84.2mm	IRS-32.8PA18: 25 $_{-0.02}^0$
IRS-32.8P(A)18D: 109.8mm	

4-3. Extension Sensor Cable Dimensions

(1) 4P-S-0140-[L] / 4P-RBT-0140-[L] / 4P-URT-0140-[L]

Units: mm

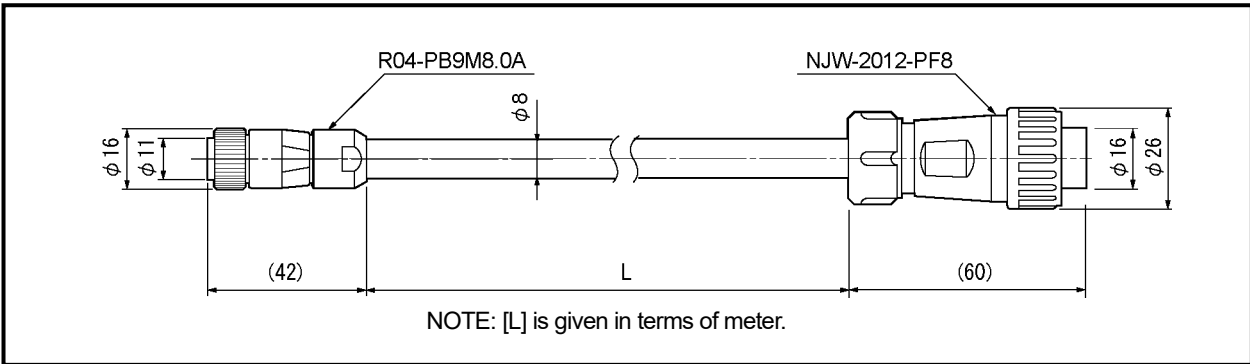

(2) 4P-S-4340-[L] / 4P-RBT-4340-[L] / 4P-URT-4340-[L] / 4P-HRT-4340-[L]

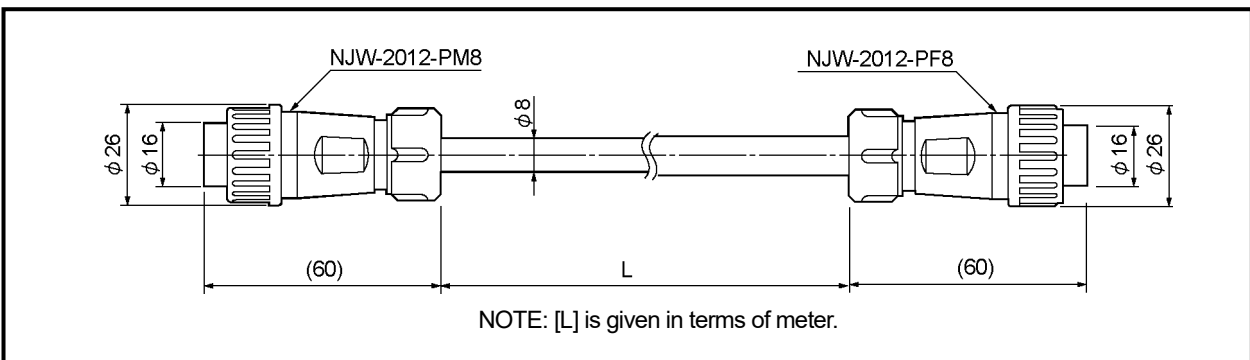

(3) 4P-S-0144-[L] / 4P-RBT-0144-[L] / 4P-URT-0144-[L]

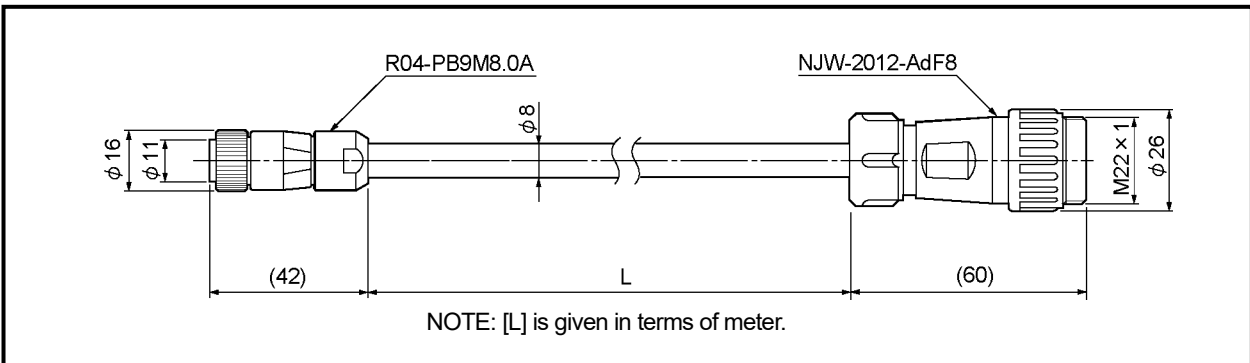

(4) 4P-S-4344-[L] / 4P-RBT-4344-[L] / 4P-URT-4344-[L] / 4P-HRT-4344-[L]

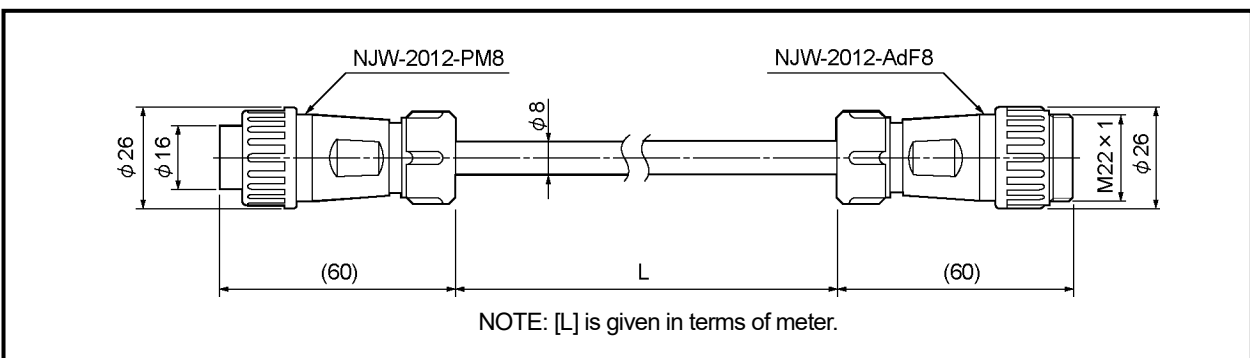

(5) 4P-S-0155-[L] / 4P-RBT-0155-[L] / 4P-URT-0155-[L]

Units: mm

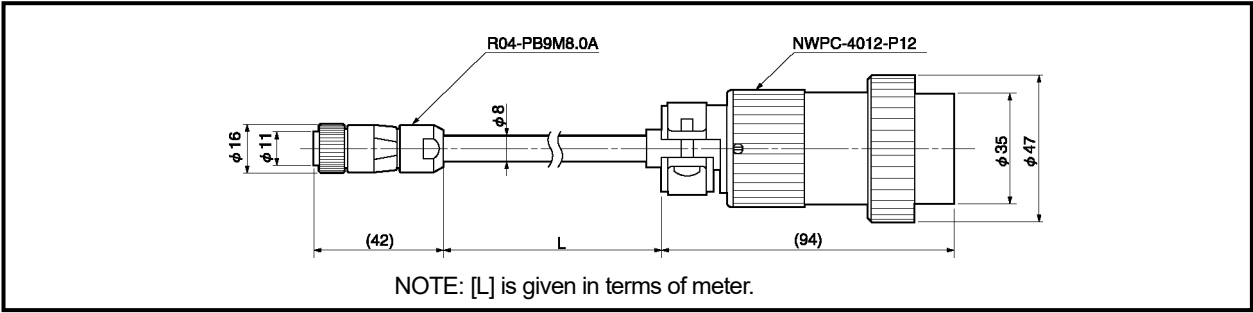

(6) 4P-S-0190-[L] / 4P-RBT-0190-[L] / 4P-URT-0190-[L]

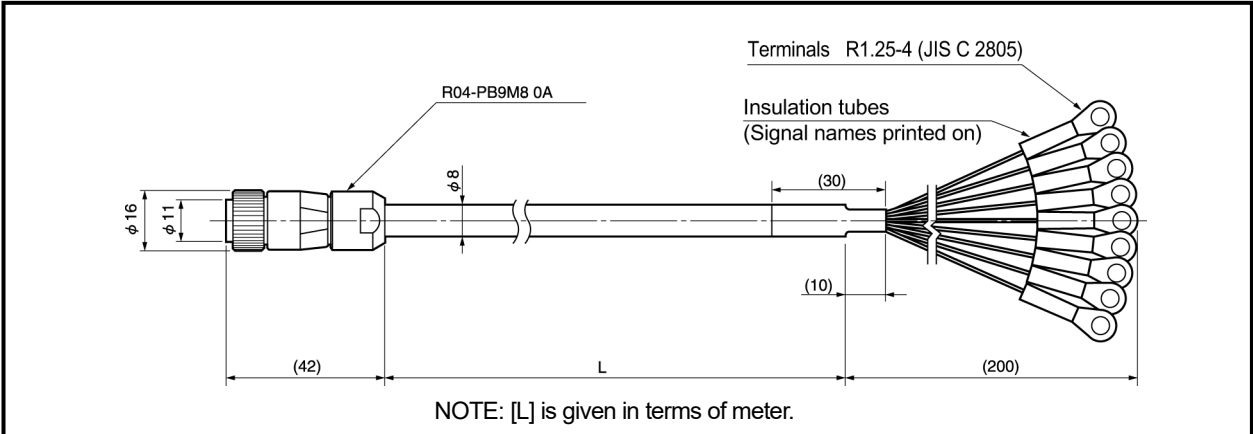

(7) 4P-S-9090-[L] / 4P-RBT-9090-[L] / 4P-URT-9090-[L] / 4P-HRT-9090-[L]

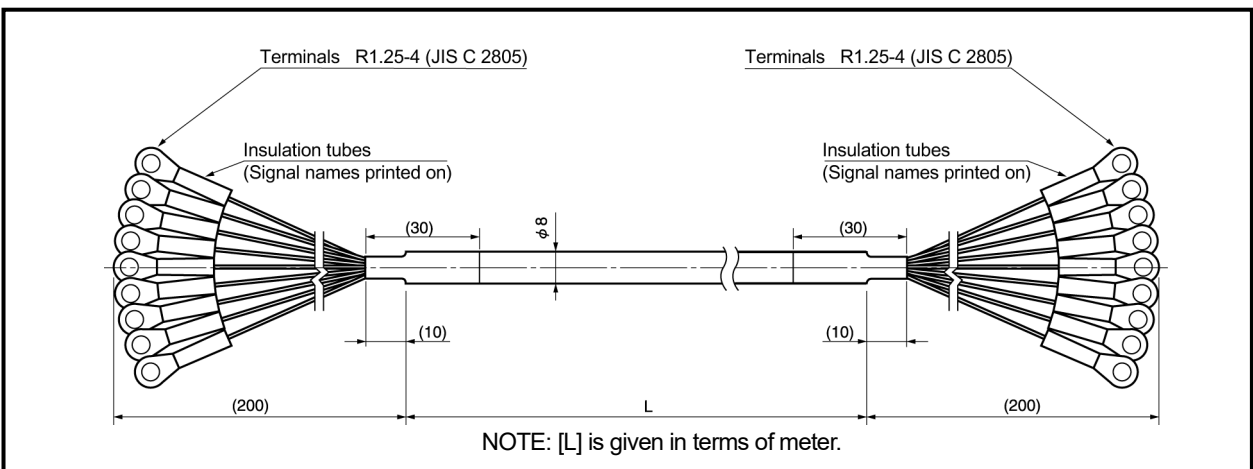

(8) 4P-S-9040-[L] / 4P-RBT-9040-[L] / 4P-URT-9040-[L] / 4P-HRT-9040-[L]

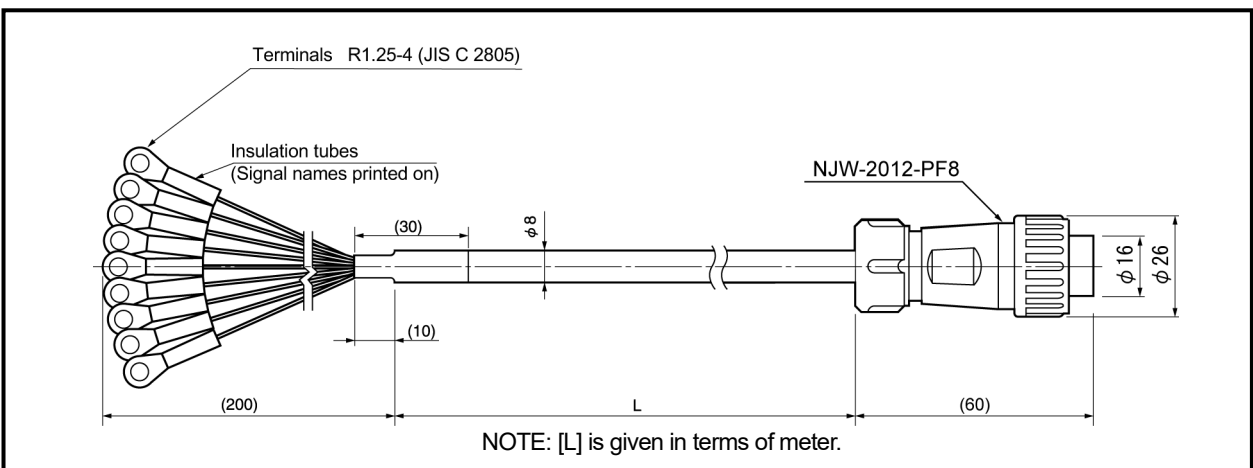

5. CHECKING THE CONTENTS OF THE SHIPPING CASE

Open the packing case, and verify that all items are present.
When extension sensor cables are ordered, they are packed separately.

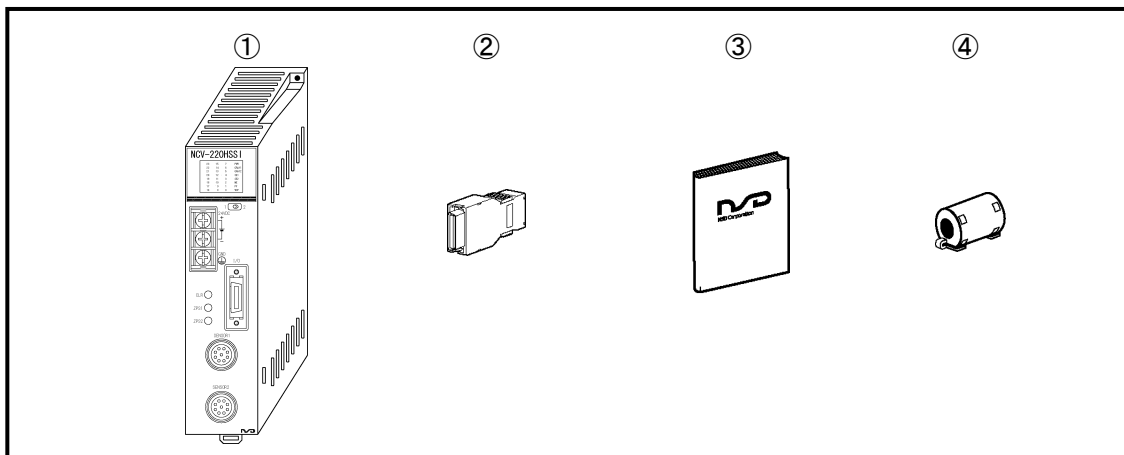

- ① Converter..... 1 unit
- ② SSI connector..... 1 piece
Connector: PCR-S20FS+
Cover: PCR-LS20LA1
Manufactured by Honda Tsushin Kogyo Co., LTD.
- ③ Manual..... 1 piece
- ④ Clamp filter..... 1 piece
Model: ZCAT3035-1330
Manufactured by TDK Corporation.

6. INSTALLATION

6-1. Converter Installation Conditions and Precautions

When installing the converter, the following conditions and precautions should be observed.

-Installation Site

- (1) Avoid sites where the unit is exposed to direct sunlight.
- (2) The ambient temperature should never exceed a 0 to 55°C range.
- (3) The ambient humidity should never exceed a 20 to 90% RH range.
- (4) Do not install the unit in areas where condensation is likely to occur (high humidity with extreme temperature changes).
- (5) Avoid sites where dust is excessive.
- (6) Do not install in areas with an excessive amount of salt and/or metal chips.
- (7) Do not install in areas where flammable and / or corrosive gases are present.
- (8) Avoid areas where splashing water, oil or chemicals are likely to occur.
- (9) Avoid areas where vibration and shocks are excessive.

-Installation cautions

- (1) Install inside the control cabinet.
- (2) Install in a vertical direction so that the characters are visible.
- (3) If a DIN rail mounting format is used, insert until the latch mechanism catches with an audible click. Secure between end plates at both sides.
- (4) In high vibration areas, secure tightly with 2 M4 screws.
- (5) Install as far from high voltage lines and power lines as possible in order to minimize noise influences.
- (6) Allow 85mm or more space at the converter's front side for plugging in and unplugging the connector.
- (7) Peripheral components should be arranged so as not to obstruct converter installation, removal, and connector plugging/unplugging.
- (8) Space out 10mm or more between the converter and peripheral components in order not to obstruct the converter's heat dissipation.

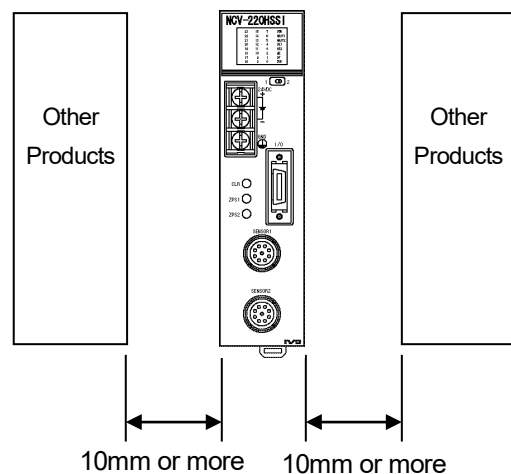
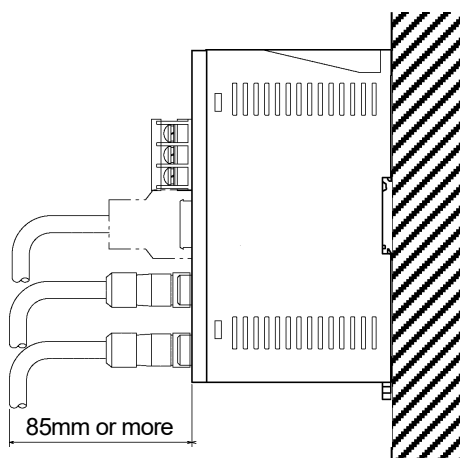

6-2. ABSOCODER Sensor Installation Conditions and Precautions

The installation conditions and precautions for ABSOCODER sensor are described in this section.

- 1) Do not apply excessive forces to the cable terminal area, and avoid damaging the cable.

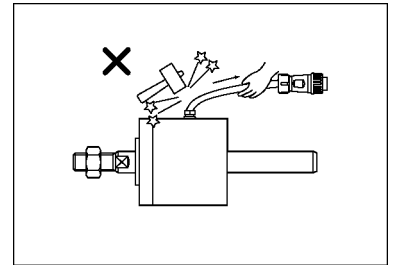

- 2) The part of a machine mounted the sensor rod must travel in the same direction as the sensor rod extends and contracts.

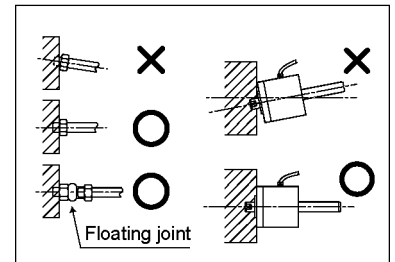

- 3) When the cable port is exposed, a shielding plate should be installed as shown in the right figure.

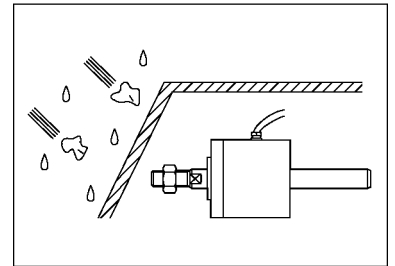

Contact your NSD representative for details of the installation conditions and precautions for ABSOCODER sensor.

7. WIRING

7-1. Connection between Converter and ABSOCODER Sensor

The maximum extension sensor cable length varies according to the ABSOCODER sensor and cable model being used. For more details refer to "3-2. ABSOCODER Sensor Specifications".

-Wiring Precautions

- (1) The sensor cable should be clamped as shown in the right figure to prevent excessive tension from being applied to the cable connectors.
- (2) The sensor cable should be located at least 300mm away from power lines and other lines which generate a high level of electrical noise.
- (3) If the cable is moved under the state of bending like a horseshoe, a robotic cable should be used. The bend radius should never be less than 75 mm.

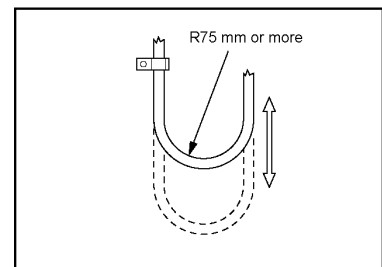
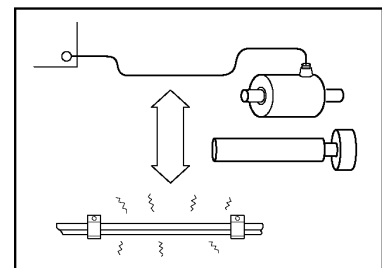
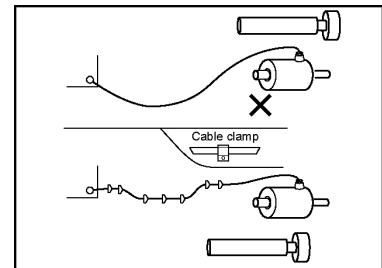

7-1-1. Connection configure example of the sensor cable

● In the case of using the NSD special cable

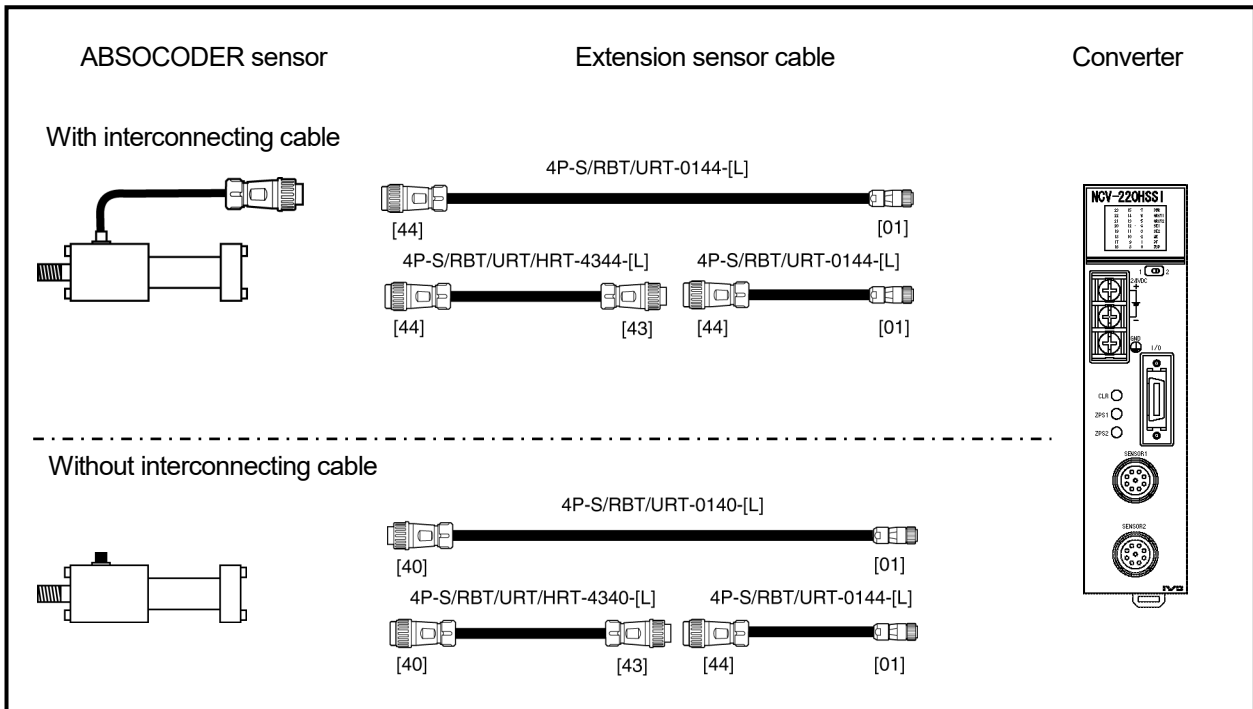

● In the case of using the NSD special cable and connecting with crimping terminals

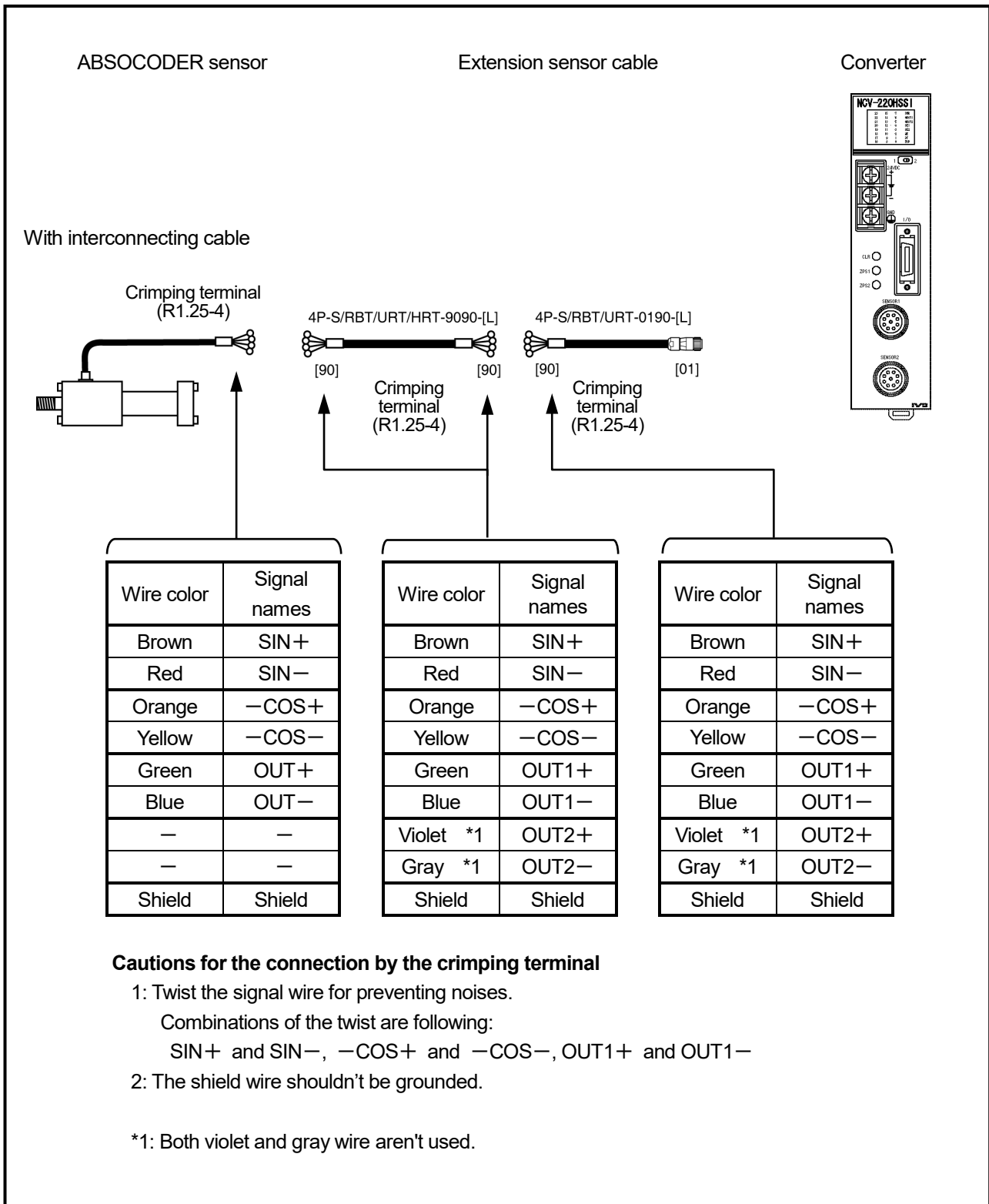

● In the case of using the NSD special cable and connecting with crimping terminals

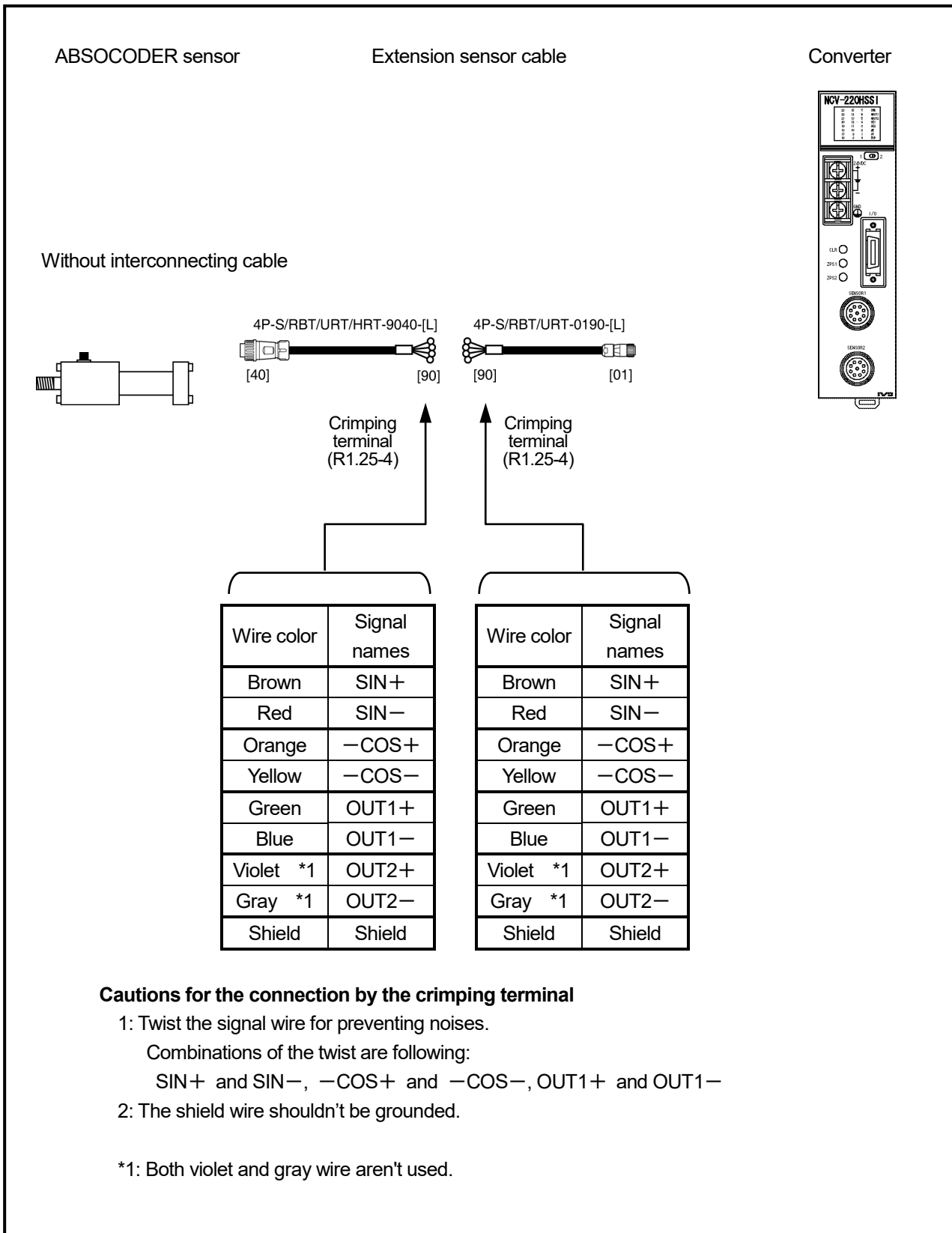

Cautions for the connection by the crimping terminal

1: Twist the signal wire for preventing noises.
 Combinations of the twist are following:
 SIN+ and SIN-, -COS+ and -COS-, OUT1+ and OUT1-

2: The shield wire shouldn't be grounded.

*1: Both violet and gray wire aren't used.

- In the case of using the commercially available cable (JKPEV-S 1.25mm² × 5P) and connecting with crimping terminals

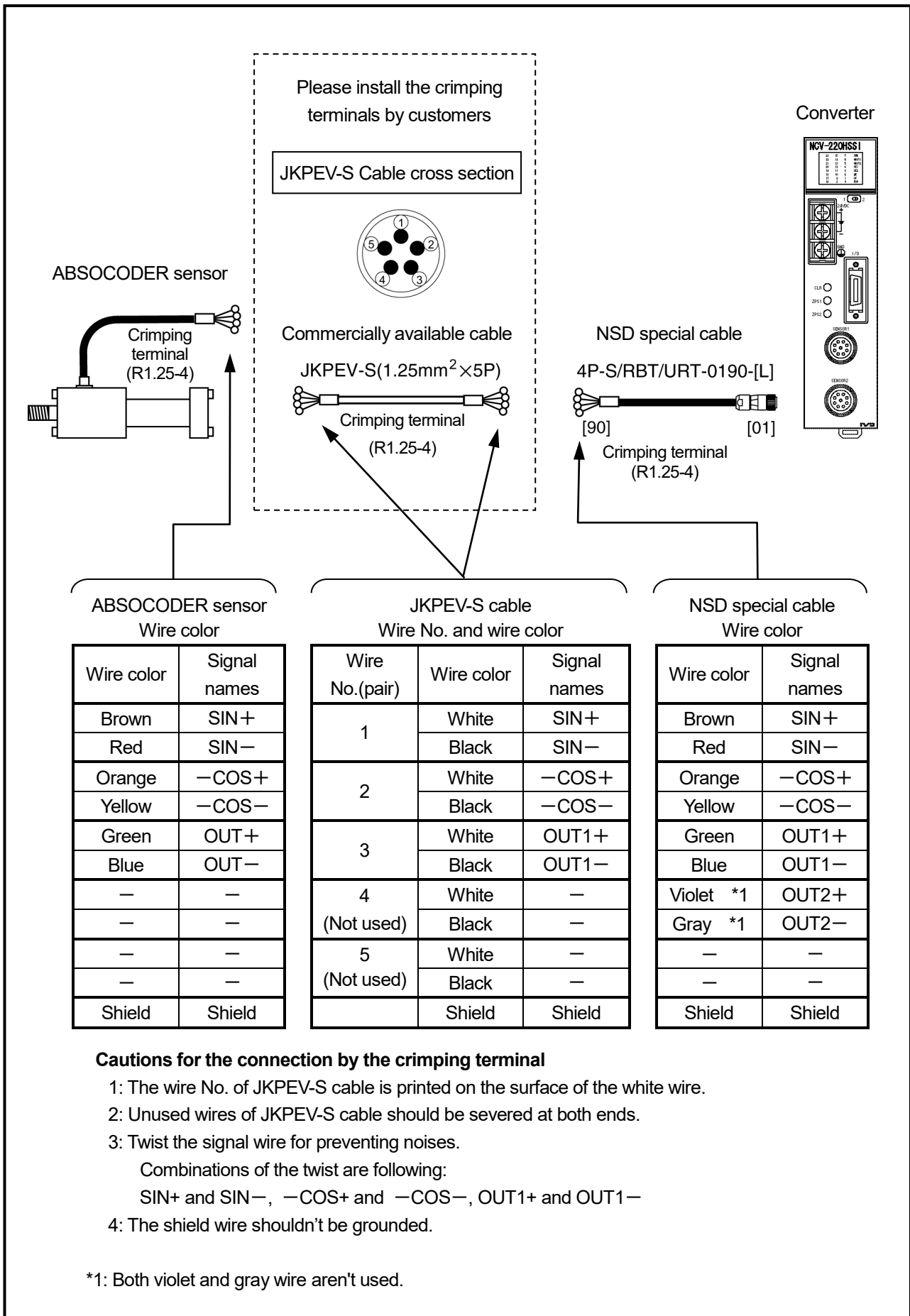

● In the case of using the commercially available cable (JKPEV-S 1.25mm²×5P) and connecting with a connector

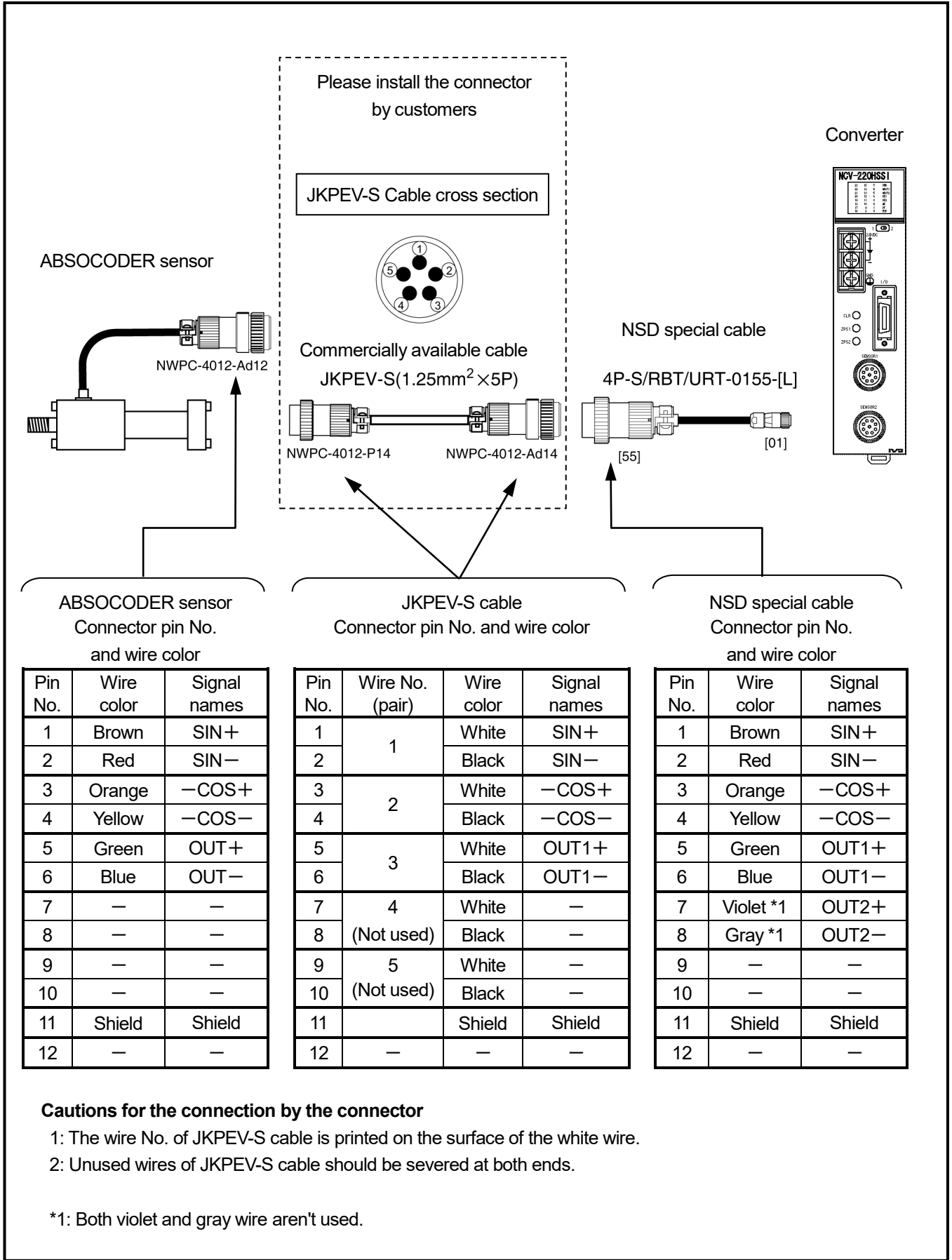

ABSOCODER sensor

Please install the connector by customers

JKPEV-S Cable cross section

Converter

Commercially available cable JKPEV-S(1.25mm²×5P)

NSD special cable

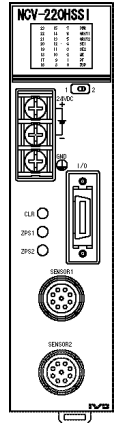
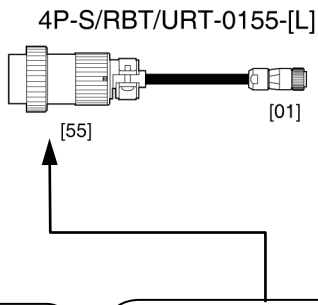
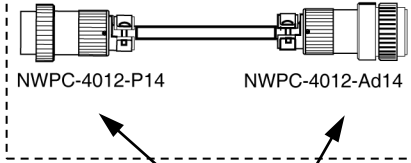
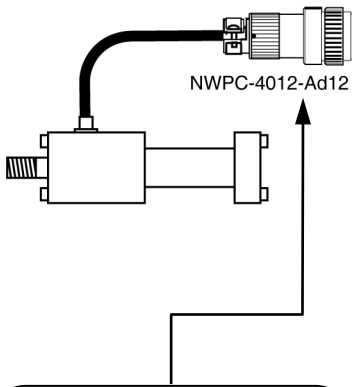

ABSOCODER sensor
Connector pin No.
and wire color

JKPEV-S cable
Connector pin No. and wire color

NSD special cable
Connector pin No.
and wire color

Pin No.	Wire color	Signal names
1	Brown	SIN+
2	Red	SIN-
3	Orange	-COS+
4	Yellow	-COS-
5	Green	OUT+
6	Blue	OUT-
7	-	-
8	-	-
9	-	-
10	-	-
11	Shield	Shield
12	-	-

Pin No.	Wire No. (pair)	Wire color	Signal names
1	1	White	SIN+
2		Black	SIN-
3	2	White	-COS+
4		Black	-COS-
5	3	White	OUT1+
6		Black	OUT1-
7	4	White	-
8	(Not used)	Black	-
9	5	White	-
10	(Not used)	Black	-
11		Shield	Shield
12	-	-	-

Pin No.	Wire color	Signal names
1	Brown	SIN+
2	Red	SIN-
3	Orange	-COS+
4	Yellow	-COS-
5	Green	OUT1+
6	Blue	OUT1-
7	Violet *1	OUT2+
8	Gray *1	OUT2-
9	-	-
10	-	-
11	Shield	Shield
12	-	-

Cautions for the connection by the connector

- 1: The wire No. of JKPEV-S cable is printed on the surface of the white wire.
- 2: Unused wires of JKPEV-S cable should be severed at both ends.

*1: Both violet and gray wire aren't used.

7-2. Power Supply Connection

The power supply should be connected as described below:

●Power Supply

- Choose the power supply capacity which is more than twice the power consumption of the converter.
The power consumption of the converter is 10W or less.
- The input power supply should be isolated from the commercial power supply.
- The power cable should be as thick as possible to minimize voltage drops.
- Twist the power cable for preventing noises.
- Use the M4 size crimp lug terminals with insulating sleeves in order to prevent short circuit caused by loose screws.
- The terminal block tightening torque is 1.8 N·m (16 lb·in).

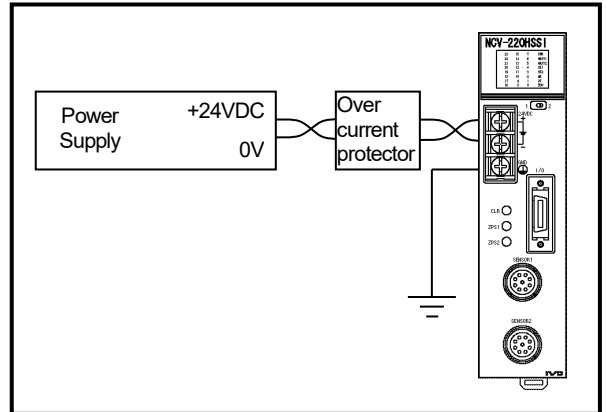

●Ground

- The unit should be securely grounded (ground resistance of 100ohm or less) to prevent electrical shocks.
- The ground wire should be connected to the ground terminal directly.
- The terminal block tightening torque is 1.8 N·m (16 lb·in).

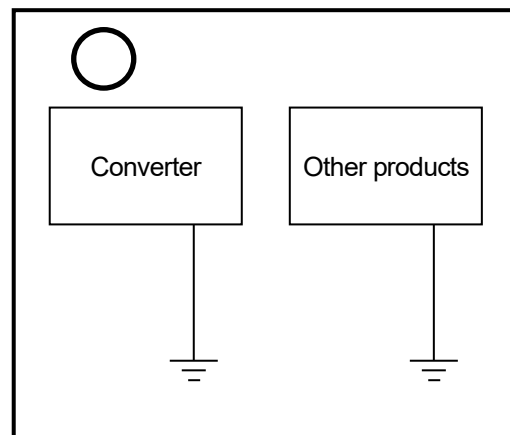
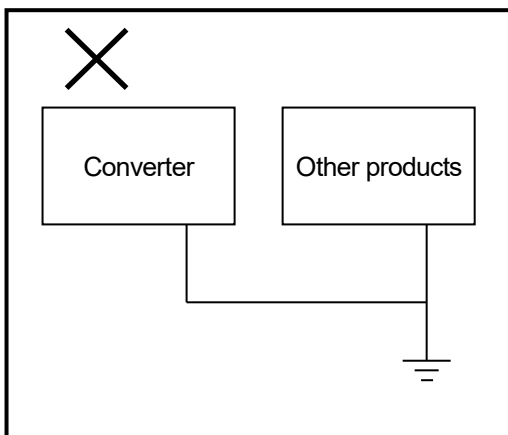

8. NOMENCLATURE

8-1. Part Identification

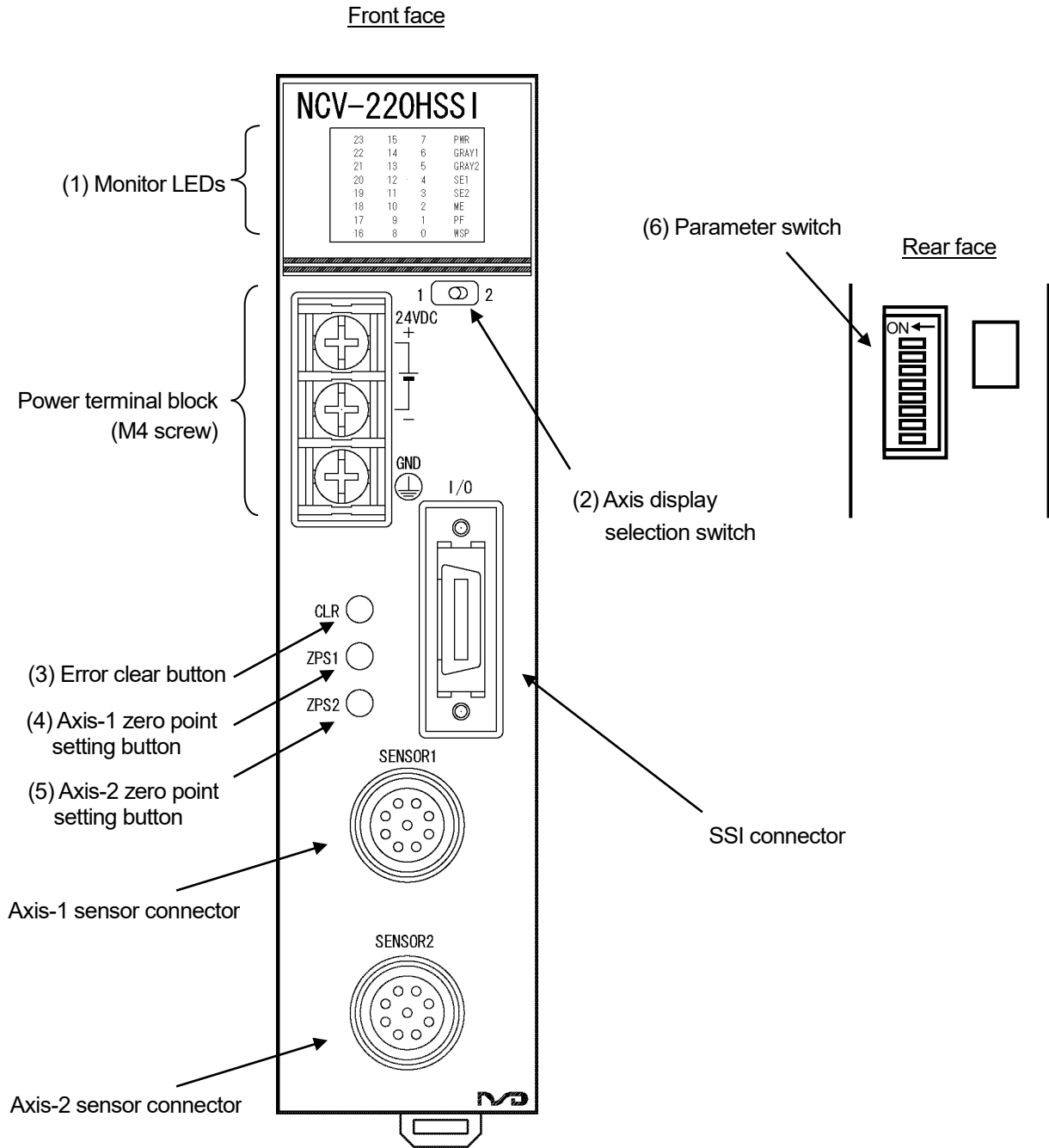

8-2. Function and Name of Display and Setting Area

(1) Monitor LEDs

Name	Description
PWR (green)	LED turns ON when the power supply is normal status.
GRAY1 (green)	LED turns ON when the axis-1 output code is gray.
GRAY2 (green)	LED turns ON when the axis-2 output code is gray.
SE1 (red)	LED turns ON when the axis-1 sensor is disconnected. LED blinks when the axis-1 sensor data error.
SE2 (red)	LED turns ON when the axis-2 sensor is disconnected. LED blinks when the axis-2 sensor data error.
ME (red)	LED turns ON when the memory has an error.
PF (red)	LED turns ON when the power supply voltage is low.
WSP (red)	LED blinks or ON when the converter has an error.
0 to 23 (green)	Indicates a position data in a binary code. The axis-1 position data is displayed when the axis display selection switch is "1". The axis-2 position data is displayed when the axis display selection switch is "2". Indicates in 0 to 23 (24-bit)

(2) Axis display selection switch

Selects the position data which is displayed on the monitor LED on the panel.

- The axis-1 current position data is displayed on monitor LED when the switch is "1".
 - The axis-2 current position data is displayed on monitor LED when the switch is "2".
- All LEDs from 0 to 23 blink when the axis-2 is not used.

(3) Error clear button [CLR]

The error display turns OFF by pressing this button [CLR] after removing an error cause. The system ready signal of the connector output turns ON.

(4) Axis-1 zero point setting button [ZPS1]

Axis-1 position data is set to "0" by pressing this button [ZPS1]. Do this procedure after moving the machine position to the zero point position (0 position).

(5) Axis-2 zero point setting button [ZPS2]

Axis-2 position data is set to "0" by pressing this button [ZPS2]. Do this procedure after moving the machine position to the zero point position (0 position).

(6) Parameter switch (Rear face)

The switch status is set as the parameter when the power supply turns ON.

The operation isn't influenced even though the switch is changed during the operation.

Switch No.	Parameter name	Switch setting	Description	Factory setting
1	Axis-1 position data increase direction	ON : CCW OFF: CW	Specify the direction in which the axis-1 position data should increase. *1	OFF
2	Axis-2 position data increase direction	ON : CCW OFF: CW	Specify the direction in which the axis-2 position data should increase. *1	OFF
3	Axis-1 output code	ON : Gray OFF: Binary	Outputs Axis-1 position data in the gray code when the setting is ON.	OFF
4	Axis-2 output code	ON : Gray OFF: Binary	Outputs Axis-2 position data in the gray code when the setting is ON.	OFF
5	Reserved	Fixed at OFF	Keep this switch in the OFF position. The correct operation cannot be guaranteed if this switch is set to the ON position.	OFF
6	Reserved	Fixed at OFF	Keep this switch in the OFF position. The correct operation cannot be guaranteed if this switch is set to the ON position.	OFF
7	Reserved	Fixed at OFF	Keep this switch in the OFF position. The correct operation cannot be guaranteed if this switch is set to the ON position.	OFF
8	Axis-2 (enabled / disabled)	ON : Disable OFF: Enable	When this switch is set to the ON position, error will not occur even if the axis-2 sensor is not connected. Axis-2 position data is "0", and monitor LEDs from 0 to 23 blink.	OFF

*1: The position data increases or decreases according to the ABSOCODER sensor's rod travel direction.

The direction in which the position data increases is specified by a switch on the converter's rear face.

Increase direction	Alteration of the position data
OFF: CW (Factory setting)	
ON : CCW	

◆ Travel direction of the rod

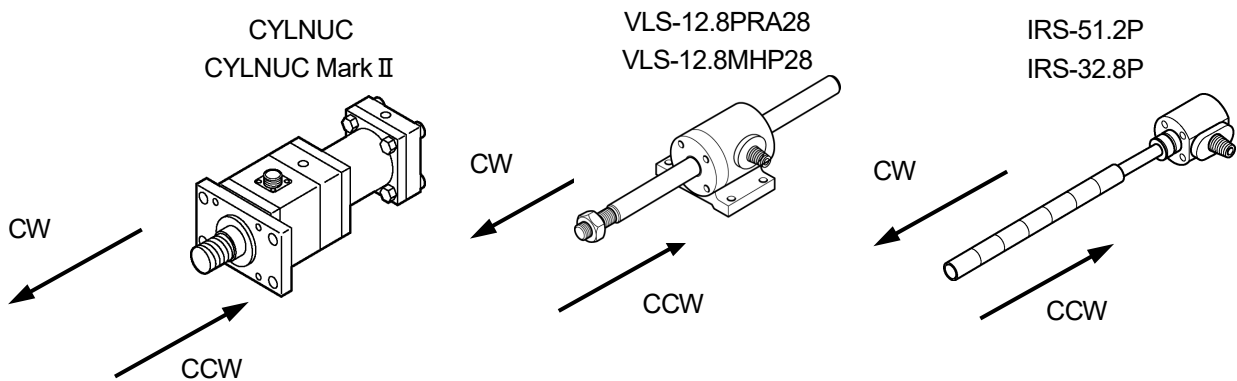

Important

Position data "increase direction" setting caution

Do not change the position data "increase direction" switch setting while the power is ON, as this could cause an accident.

9. OPERATION

9-1. Operation Sequence

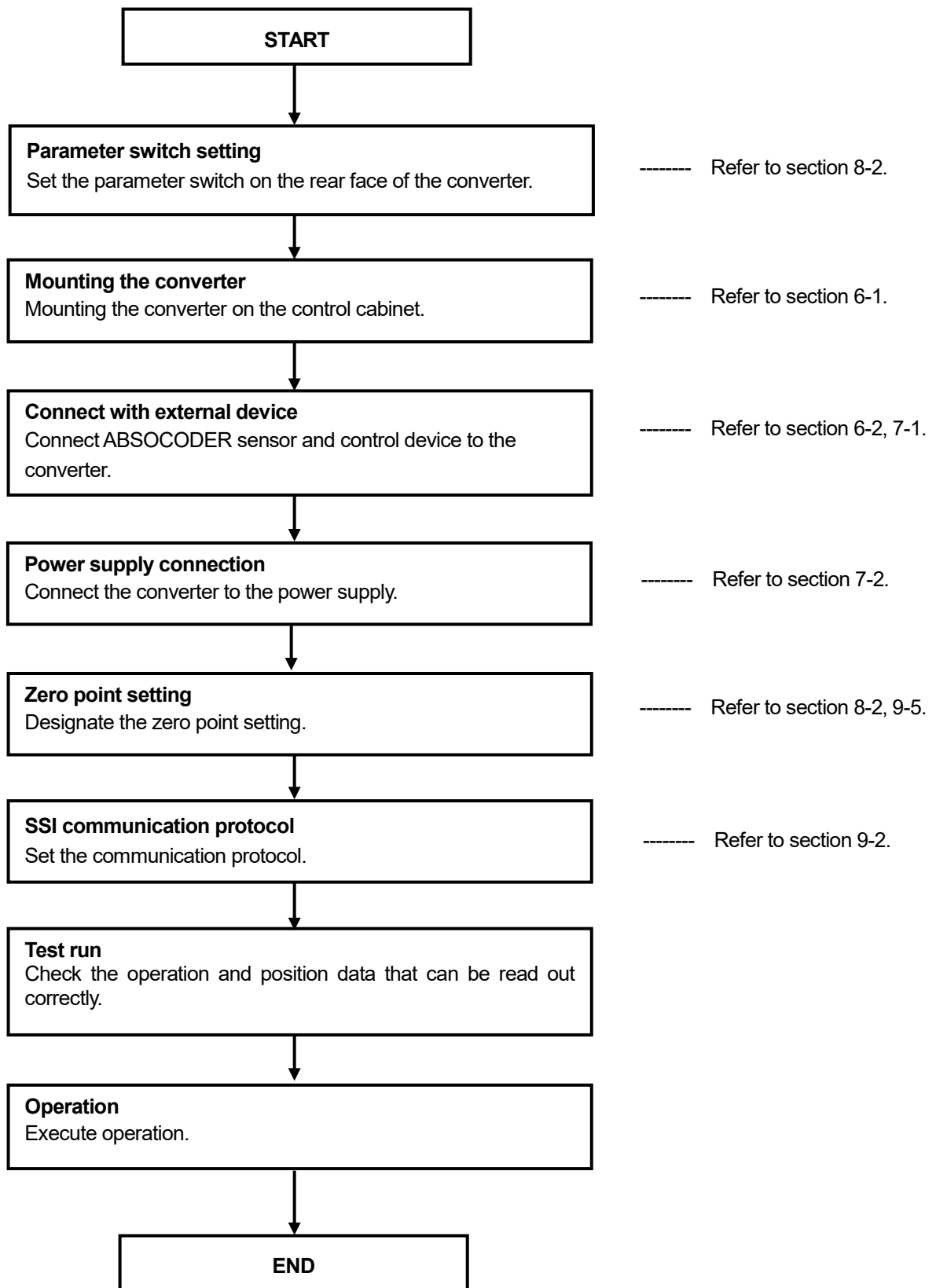

9-2. SSI Communication Protocol

bit	1	2	3	4	5	6	7	8	9	10	11	12	13	14	15	16	17	18	19	20	21	22	23	24	25
data	0	D	D	D	D	D	D	D	D	D	D	D	D	D	D	D	D	D	D	D	D	D	D	D	D
		23	22	21	20	19	18	17	16	15	14	13	12	11	10	9	8	7	6	5	4	3	2	1	0

- (1) Set the following of the host PLC side.
- Absolute Sensor *1 (the data length): 25-bit.
 - Steps/Revolutions *1: 8192.

*1 The items name is written when using SM338 manufactured by SIEMENS AG.

9-3. SSI Communication Timing Chart

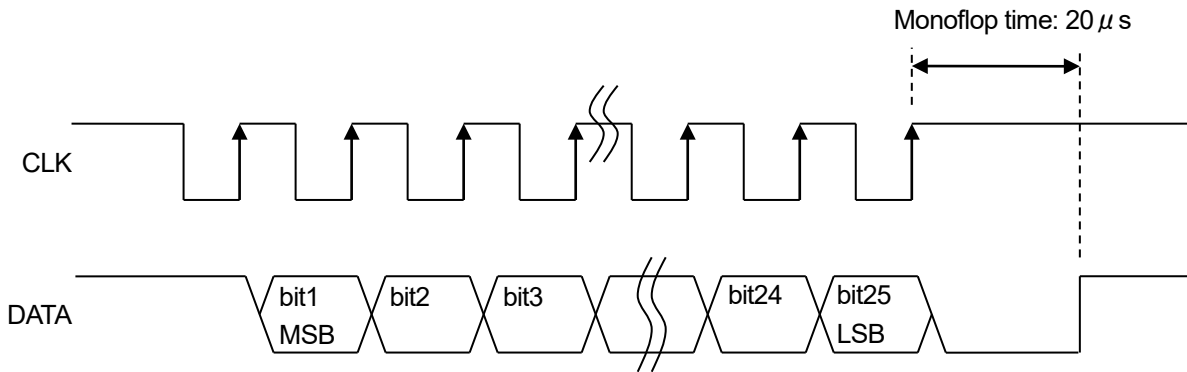

- (1) The newest DATA is latched and MSB is sent to the DATA line when the first CLK rises.
 After that, the DATA is sent at each clock rising until LSB.
 The DATA will be "L" after DATA is sent until LSB. (monoflop time)
- (2) The same DATA will be sent from MSB again when the CLK is supplied newly within monoflop time.
 The DATA becomes "H" when the CLK isn't supplied newly within the monoflop time.
 After time passes more than monoflop time, the newest data will send from MSB again when CLK rises.

9-4. Error Clear Input (CLR)

The chart below indicates the error clear input timing.

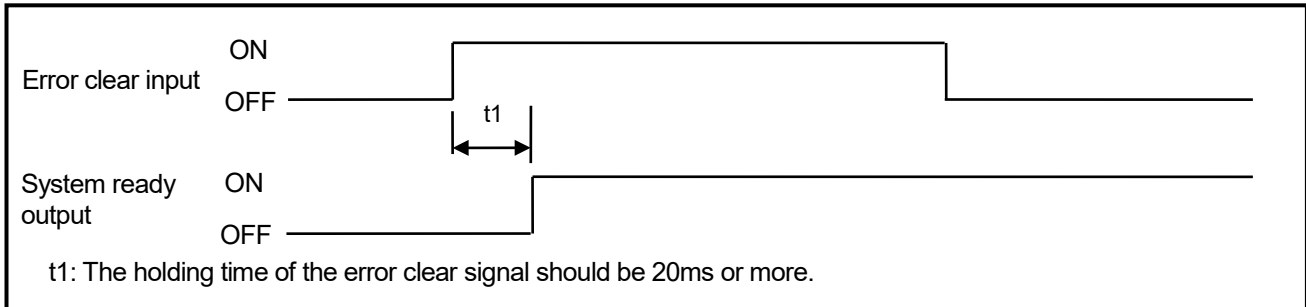

Important

The error clear input must be ON 20ms or more.
The error clear signal must be turned OFF after clearing the error.

9-5. Zero Point Setting Input (ZPS1, ZPS2)

The chart below indicates the zero point setting input timing.

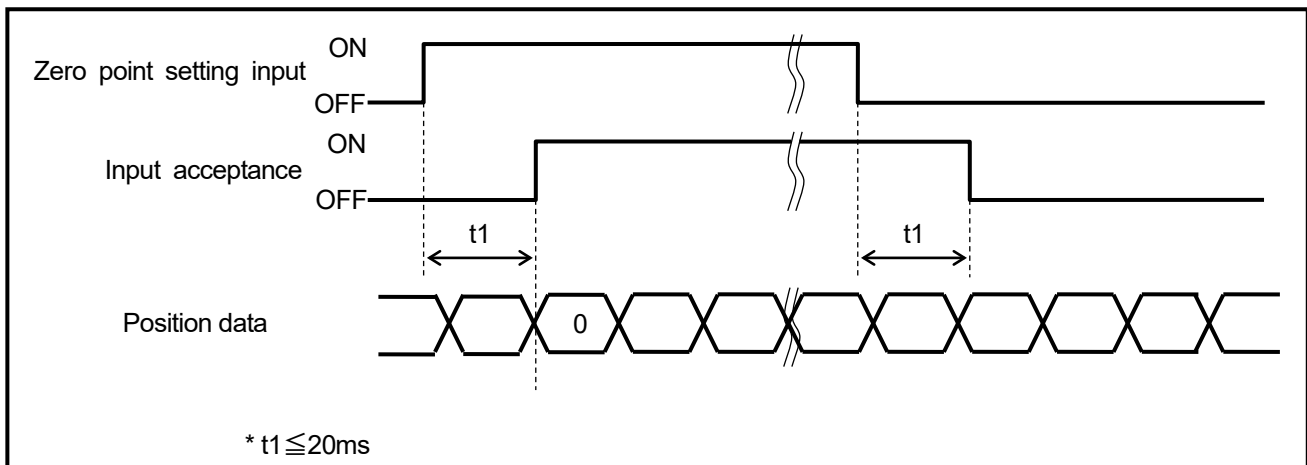

Important

The zero point setting input must be ON 20ms or more.
The zero point setting signal must be turned OFF after setting the zero point.

9-6. System Ready Signal Output (NOR1, NOR2)

The system ready signal indicates that the normal position data is output from the converter.

The signal is ON when ABSOCODER sensor and converter operate normally.

For your safety, read the position data when the system ready signal is ON.

The following figure indicates the timing from turning ON the power supply to outputting the system ready signal.

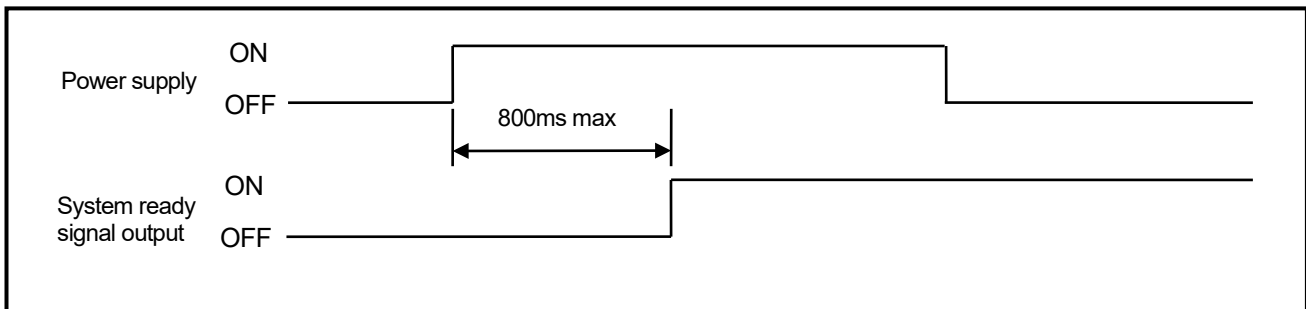

10. INSPECTION

The inspection should be conducted once every 6 months to a year.

Any inspected items which do not satisfy the criteria shown below should be repaired

Inspection item	Inspection Description	Criteria	Remark
Power supply	Measure the voltage fluctuation at the power supply terminal block of the converter to determine if it is within the prescribed range.	Within 21.6V to 26.4VDC range	Tester
Ambient Conditions	Check the ambient temperature.	ABSOCODER sensor VLS-12.8PRA28: -20 to +120°C VLS-12.8MHP28: -20 to +120°C IRS-51.2P: -20 to +120°C *1 IRS-32.8P: -20 to +120°C Converter: 0 to +55°C	Thermometer
	There should be no accumulation of dust.	None	
Mount Conditions	Verify that the sensor is securely mounted.	There should be no looseness.	Visual Inspection
	Verify that the sensor rod is securely coupled to the machine.	There should be no looseness.	
	Check for severed cables.	Cable should appear normal.	
	Verify that the sensor cable connector is plugged in all the way.	There should be no looseness.	
	Verify that the SSI connector is plugged in all the way.	There should be no looseness.	

*1: For CYLNUC Cylinder and CYLNUC Mark II Cylinder, contact your NSD representative.

11. TROUBLESHOOTING

11-1. Display and Countermeasure when an Error Occurred

Error monitor	Name	Probable cause	Error cancel procedures
"SE 1" or "SE 2" LED is ON	Sensor disconnected error *1	Sensor connector is disconnected or loose.	After removing an error cause, clear the error by either way: - Press CLR button. - Turn ON the error clear input signal.
		Sensor cable is severed.	Replace the sensor cable.
		ABSOCODER sensor failure	Replace the ABSOCODER sensor.
		Converter failure	Replace the converter.
"SE 1" or "SE 2" LED blinks	Sensor data error *1	Sensor connector is loose.	After removing an error cause, clear the error by either way: - Press CLR button. - Turn ON the error clear input signal.
		ABSOCODER sensor was shocked excessively.	
		Wiring has a noise source	
		Sensor cable is severed.	Replace the sensor cable.
"PF" LED is ON	Low power supply error	Voltage drop of the power supply. Instantaneous power failure of the power supply.	After removing an error cause, clear the error by either way: - Press CLR button. - Turn ON the error clear input signal.
"ME" LED is ON	Memory error	Memory data has been changed due to external noise, etc.	After moving the machine to the zero point, press "ZPS1" and "ZPS2" buttons at same time in order to clear an error. NOTE The position data is changed to "0" when clearing the error. (The zero point setting is executed.)
"WSP" LED is ON	Converter error	Watchdog timer error occurs.	Replace the converter.
"WSP" LED blinks	Converter error	Converter failure	Replace the converter.

*1: The sensor disconnected error would be displayed, if both the sensor disconnected error and sensor data error are occurred at the same time.

Note

The error wouldn't be cleared if a cause isn't removed.

11-2. Error Clear Method

The error clear is executed by following methods.

(1) In the case of clearing SE and PE

- Press the error clear button [CLR] on the front panel.
- Turn on the error clear input signal [CLR] in the I/O connector from PLC or host controller.

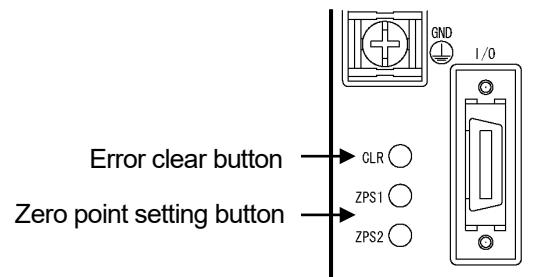

(2) In the case of clearing ME

- Press both zero point setting buttons [ZPS1 and ZPS2] on the front panel at the same time.

11-3. ABSOCODER Sensor Check List

11-3-1. CYLNUC Cylinder

- Applicable ABSOCODER sensor models
SCM, SCJ, SCMJ, SCJJ, SCHH, SCAH, CSAH

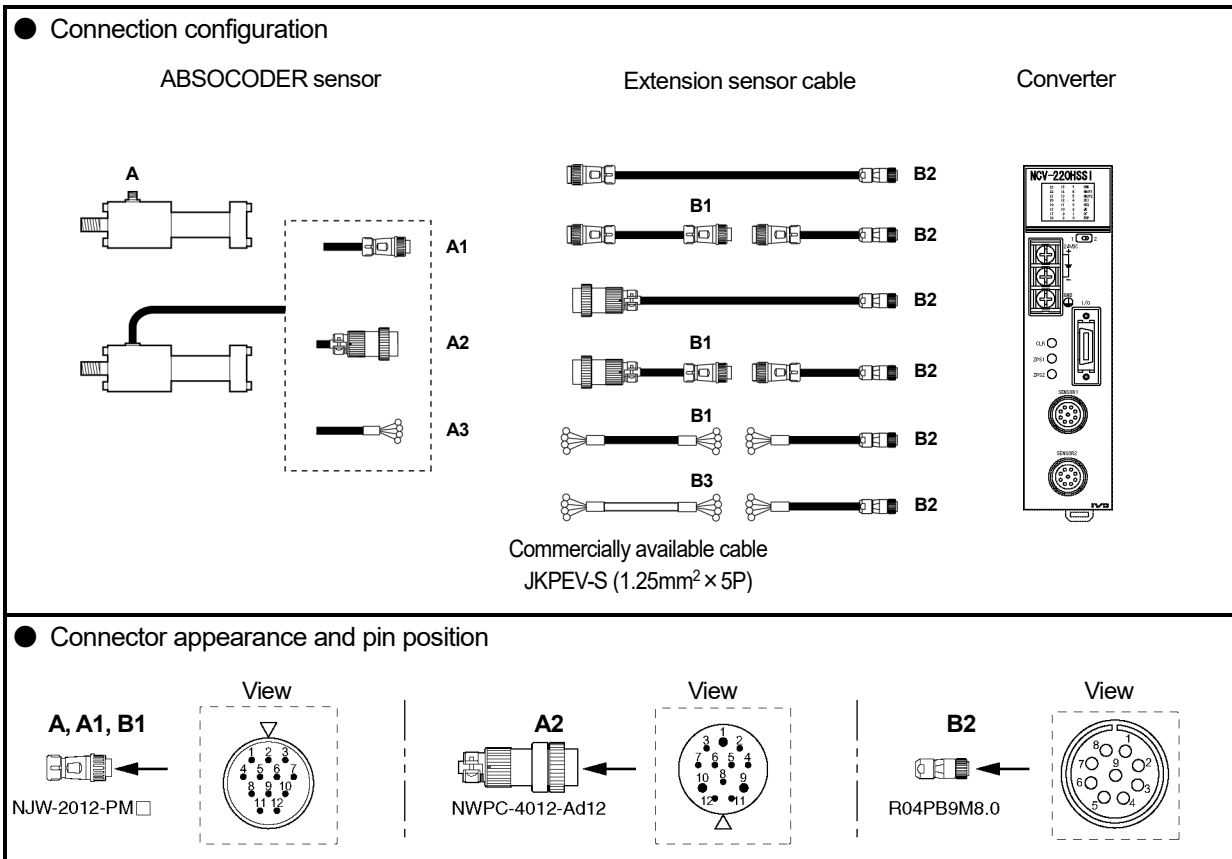

- Connector pin position and standard coil resistance ranges (at 25°C)

The standard coil resistance ranges shown below are referential data to assist wiring disconnection diagnosis and are not product specification values. There may be no wiring disconnection even when the resistance measurement is out of the standard resistance range.

◆SCM, SCJ, SCMJ, SCJJ

Check position						Signal names	Standard coil resistance [Ω]									
A, A1, A2, A3, B1		B2		B3			Rod diameter									
Pin No.	Wiring color	Pin No.	Wiring color	Wire No. (pair)	Wiring color		ϕ 22.4	ϕ 28	ϕ 36	ϕ 45	ϕ 56	ϕ 63	ϕ 70	ϕ 80	ϕ 90	ϕ 100
1	Brown	1	Brown	1	White	SIN+	20 to 66	23 to 69	25 to 71	40 to 86	45 to 110	49 to 114	50 to 115	53 to 118	50 to 115	54 to 119
2	Red	2	Red		Black	SIN-	20 to 66	23 to 69	25 to 71	40 to 86	45 to 110	49 to 114	50 to 115	53 to 118	50 to 115	54 to 119
3	Orange	3	Orange	2	White	-COS+	20 to 66	23 to 69	25 to 71	40 to 86	45 to 110	49 to 114	50 to 115	53 to 118	50 to 115	54 to 119
4	Yellow	4	Yellow		Black	-COS-	20 to 66	23 to 69	25 to 71	40 to 86	45 to 110	49 to 114	50 to 115	53 to 118	50 to 115	54 to 119
5	Green	5	Green	3	White	OUT+	57 to 83	61 to 87	63 to 89	81 to 107	88 to 128	97 to 137	137 to 177	150 to 190	156 to 196	106 to 146
6	Blue	6	Blue		Black	OUT-	57 to 83	61 to 87	63 to 89	81 to 107	88 to 128	97 to 137	137 to 177	150 to 190	156 to 196	106 to 146
7	-	7	Violet	4	White	-										
8	-	8	Gray		Black	-										
9	-	-	-	5	White	-										
10	-	-	-		Black	-										
11	Shield	9	Shield	-	Shield	Shield										
12	-	-	-	-	-	-										

◆SCAH, SCHH

Check position						Signal names	Standard coil resistance [Ω]				
A, A1, A2, A3, B1		B2		B3			Cylinder bore size, shown in () are rod diameter				
Pin No.	Wiring color	Pin No.	Wiring color	Wire No. (pair)	Wiring color		$\phi 40$ ($\phi 18$)	$\phi 50$ ($\phi 20$)	$\phi 63$ ($\phi 22.4$)	$\phi 80$ ($\phi 28$)	$\phi 100$ ($\phi 36$)
1	Brown	1	Brown	1	White	SIN+	80 to 175	85 to 180	90 to 185	100 to 245	100 to 290
2	Red	2	Red		Black	SIN-					
3	Orange	3	Orange	2	White	-COS+	80 to 175	85 to 180	90 to 185	100 to 245	100 to 290
4	Yellow	4	Yellow		Black	-COS-					
5	Green	5	Green	3	White	OUT+	235 to 265	245 to 275	275 to 305	300 to 340	315 to 375
6	Blue	6	Blue		Black	OUT-					
7	-	7	Violet	4	White	-					
8	-	8	Gray		Black	-					
9	-	-	-	5	White	-					
10	-	-	-		Black	-					
11	Shield	9	Shield	-	Shield	Shield					
12	-	-	-	-	-	-					

◆CSAH

Check position						Signal names	Standard coil resistance [Ω]	
A, A1, A2, A3, B1		B2		B3			Cylinder bore size, shown in () are rod diameter	
Pin No.	Wiring color	Pin No.	Wiring color	Wire No. (pair)	Wiring color		$\phi 20$ ($\phi 10$)	$\phi 40$ ($\phi 14$)
1	Brown	1	Brown	1	White	SIN+	61 to 136	71 to 146
2	Red	2	Red		Black	SIN-		
3	Orange	3	Orange	2	White	-COS+	61 to 136	71 to 146
4	Yellow	4	Yellow		Black	-COS-		
5	Green	5	Green	3	White	OUT+	185 to 215	203 to 233
6	Blue	6	Blue		Black	OUT-		
7	-	7	Violet	4	White	-		
8	-	8	Gray		Black	-		
9	-	-	-	5	White	-		
10	-	-	-		Black	-		
11	Shield	9	Shield	-	Shield	Shield		
12	-	-	-	-	-	-		

● Circuit resistance check

[Measurement method]

Measure resistance at Point A or B using a circuit tester or other appropriate device.
 Have Point A connected to measure at Point B.
 If the connector is off, identify the line by the wiring color.

[Check details]

Refer to the previous page for the connector pin number.

Check position	Criterion	Check position	Criterion
Between brown and red	The measured value should be in the range of the standard coil resistance. *1	Between brown and orange, green, shield	∞
Between orange and yellow		Between orange and green, shield	
Between green and blue		Between green and shield	
		Between frame and each wire or shield	

*1: If checks are done at Point B, the measurement value is [Standard coil resistance + extension sensor cable resistance].

Extension sensor cable resistance value

The resistance value of the NSD special cable is 0.2Ω/m (loop resistance).

The resistance value of the JKPEV-S cable is 0.034Ω/m (loop resistance).

Consider resistance variations due to temperature, which, relative to the standard temperature (25°C), increases 0.4% when the temperature rises 1°C and decreases 0.4% when the temperature falls 1°C.

● Insulation check

[Measurement method]

Measure using a 500 VDC insulation tester.

[Check details]

Refer to the previous page for the connector pin number.

Check position	Criterion
Between brown and orange, green, shield	10MΩ or more
Between orange and green, shield	
Between green and shield	
Between frame and each wire or shield	

 **NOTES**

1. Make sure to disconnect the ABSOCODER sensor from the converter before carrying out insulation checks.
2. If there is a risk that energization may cause damages to the electronic circuits in and around the machine, remove the ABSOCODER sensor from the machine.
3. After completing the checks, short-circuit between the pins to discharge remaining voltage before connecting the ABSOCODER sensor to the converter.

- MEMO -

11-3-2. Inrodsensor

- Applicable ABSOCODER sensor models
IRS-51.2P18, IRS-51.2P30, IRS-32.8P18
M I I M, M I I J, M I I M J, M I I J J

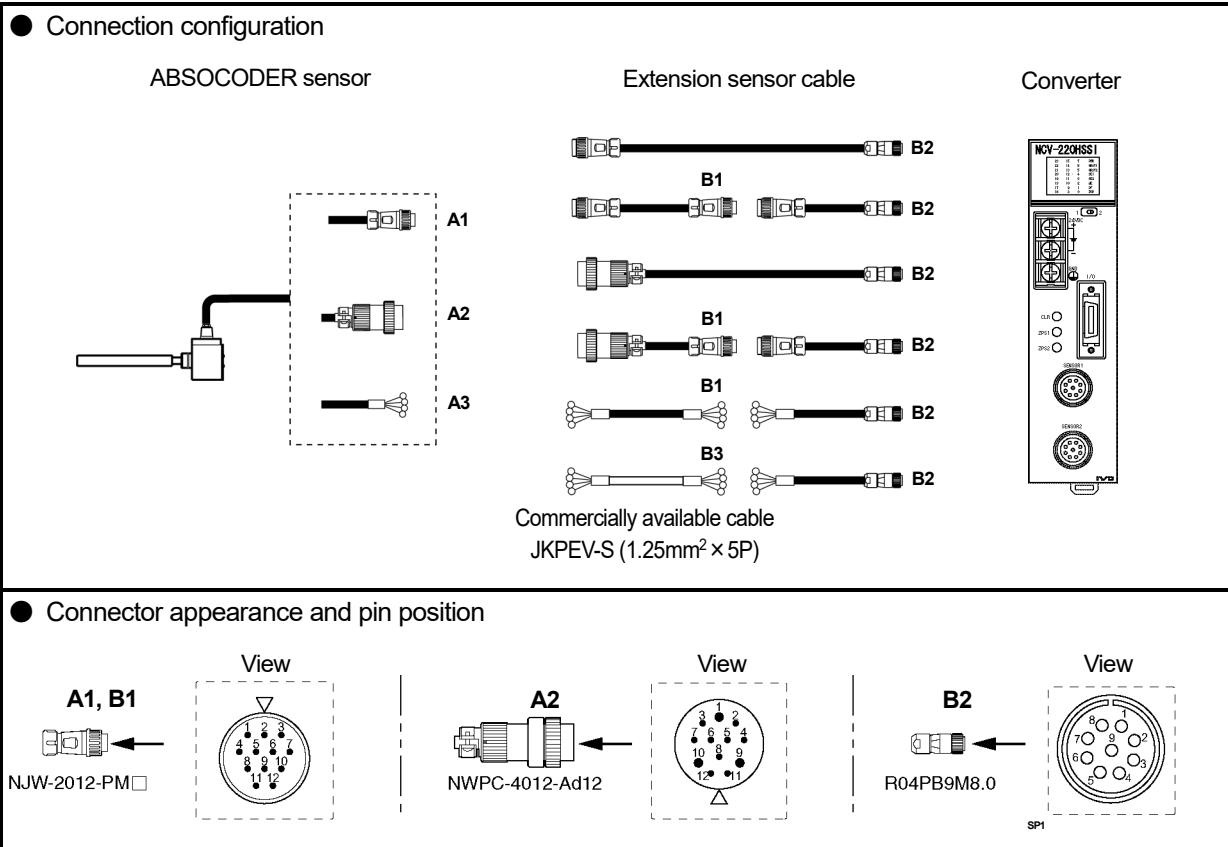

- Connector pin position and standard coil resistance ranges (at 25°C)

Check position						Signal names	Standard coil resistance [Ω]		
A1, A2, A3, B1		B2		B3			IRS-51.2P18 (ϕ 18)	IRS-51.2P30 (ϕ 30)	IRS-32.8P18 (ϕ 18)
Pin No.	Wiring color	Pin No.	Wiring color	Wire No. (pair)	Wiring color				
1	Brown	1	Brown	1	White	SIN+	19 to 59	104 to 174	42 to 82
2	Red	2	Red		Black	SIN-			
3	Orange	3	Orange	2	White	-COS+	19 to 69	104 to 174	42 to 82
4	Yellow	4	Yellow		Black	-COS-			
5	Green	5	Green	3	White	OUT+	103 to 123	331 to 371	103 to 123
6	Blue	6	Blue		Black	OUT-			
7	-	7	Violet	4	White	-			
8	-	8	Gray		Black	-			
9	-	-	-	5	White	-			
10	-	-	-		Black	-			
11	Shield	9	Shield	-	Shield	Shield			
12	-	-	-	-	-	-			

The above standard coil resistance ranges are referential data to assist wiring disconnection diagnosis and are not product specification values. There may be no wiring disconnection even when the resistance measurement is out of the standard resistance range.

● Circuit resistance check

[Measurement method]

Measure resistance at Point A or B using a circuit tester or other appropriate device.
 Have Point A connected to measure at Point B.
 If the connector is off, identify the line by the wiring color.

[Check details]

Refer to the previous page for the connector pin number.

Check position	Criterion	Check position	Criterion
Between brown and red	The measured value should be in the range of the standard coil resistance. *1	Between brown and orange, green, shield	∞
Between orange and yellow		Between orange and green, shield	
Between green and blue		Between green and shield	
		Between frame and each wire or shield	

*1: If checks are done at Point B, the measurement value is [Standard coil resistance + extension sensor cable resistance].

Extension sensor cable resistance value

The resistance value of the NSD special cable is 0.2Ω/m (loop resistance).

The resistance value of the JKPEV-S cable is 0.034Ω/m (loop resistance).

Consider resistance variations due to temperature, which, relative to the standard temperature (25°C), increases 0.4% when the temperature rises 1°C and decreases 0.4% when the temperature falls 1°C.

● Insulation check

[Measurement method]

Measure using a 500 VDC insulation tester.

[Check details]

Refer to the previous page for the connector pin number.

Check position	Criterion
Between brown and orange, green, shield	10MΩ or more
Between orange and green, shield	
Between green and shield	
Between frame and each wire or shield	

 NOTES
<ol style="list-style-type: none"> 1. Make sure to disconnect the ABSOCODER sensor from the converter before carrying out insulation checks. 2. If there is a risk that energization may cause damages to the electronic circuits in and around the machine, remove the ABSOCODER sensor from the machine. 3. After completing the checks, short-circuit between the pins to discharge remaining voltage before connecting the ABSOCODER sensor to the converter.

11-3-3. Rod sensor

- Applicable ABSOCODER sensor models
VLS-12.8MHP28
VLS-12.8PRA28

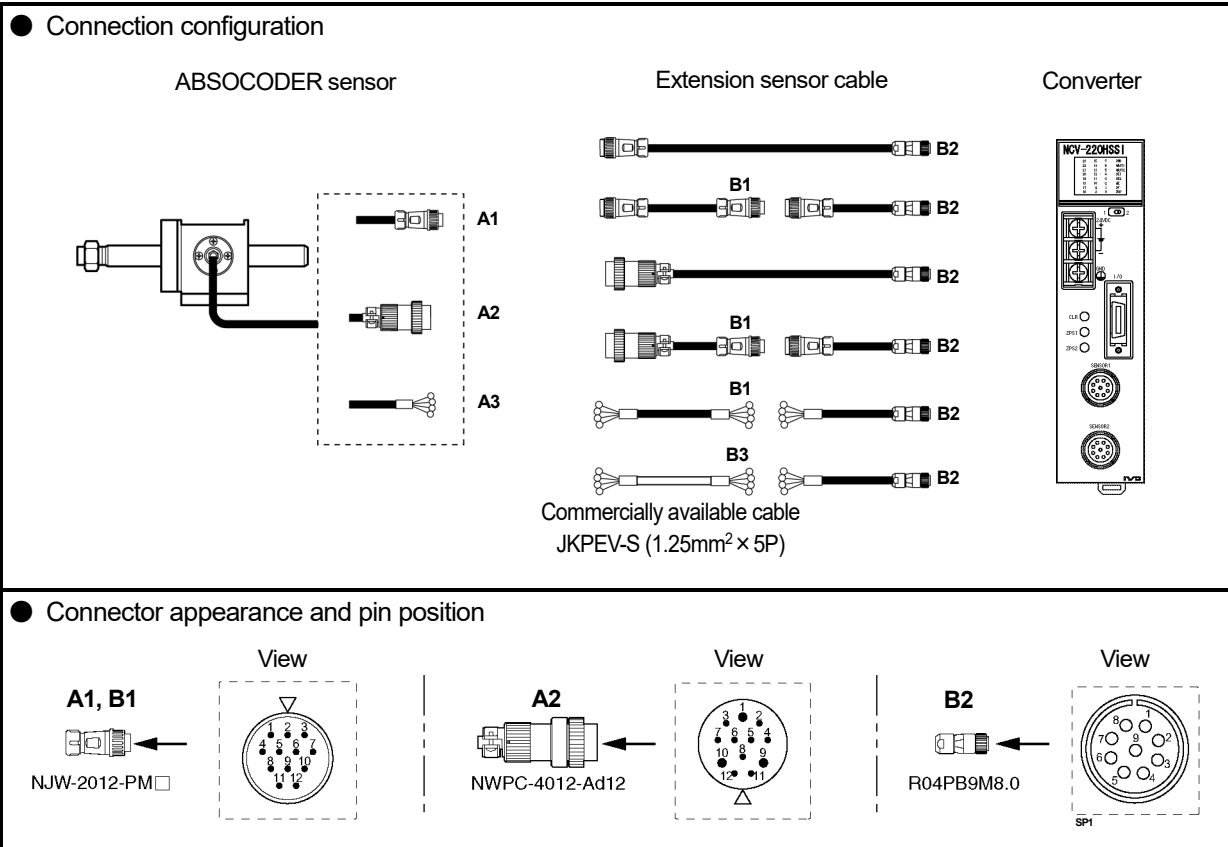

- Connector pin position and standard coil resistance ranges (at 25°C)

Check position						Signal names	Standard coil resistance [Ω]	
A1, A2, A3, B1		B2		B3			VLS-12.8PRA28	VLS-12.8MHP28
Pin No.	Wiring color	Pin No.	Wiring color	Wire No. (pair)	Wiring color			
1	Brown	1	Brown	1	White	SIN+	100 to 245	23 to 69
2	Red	2	Red		Black	SIN-		
3	Orange	3	Orange	2	White	-COS+	100 to 245	23 to 69
4	Yellow	4	Yellow		Black	-COS-		
5	Green	5	Green	3	White	OUT+	300 to 340	61 to 87
6	Blue	6	Blue		Black	OUT-		
7	-	7	Violet	4	White	-		
8	-	8	Gray		Black	-		
9	-	-	-	5	White	-		
10	-	-	-		Black	-		
11	Shield	9	Shield	-	Shield	Shield		
12	-	-	-	-	-	-		

The above standard coil resistance ranges are referential data to assist wiring disconnection diagnosis and are not product specification values. There may be no wiring disconnection even when the resistance measurement is out of the standard resistance range.

● Circuit resistance check

[Measurement method]

Measure resistance at Point A or B using a circuit tester or other appropriate device.
 Have Point A connected to measure at Point B.
 If the connector is off, identify the line by the wiring color.

[Check details]

Refer to the previous page for the connector pin number.

Check position	Criterion	Check position	Criterion
Between brown and red	The measured value should be in the range of the standard coil resistance. *1	Between brown and orange, green, shield	∞
Between orange and yellow		Between orange and green, shield	
Between green and blue		Between green and shield	
		Between frame and each wire or shield	

*1: If checks are done at Point B, the measurement value is [Standard coil resistance + extension sensor cable resistance].

Extension sensor cable resistance value

The resistance value of the NSD special cable is 0.2Ω/m (loop resistance).

The resistance value of the JKPEV-S cable is 0.034Ω/m (loop resistance).

Consider resistance variations due to temperature, which, relative to the standard temperature (25°C), increases 0.4% when the temperature rises 1°C and decreases 0.4% when the temperature falls 1°C.

● Insulation check

[Measurement method]

Measure using a 500 VDC insulation tester.

[Check details]

Refer to the previous page for the connector pin number.

Check position	Criterion
Between brown and orange, green, shield	10MΩ or more
Between orange and green, shield	
Between green and shield	
Between frame and each wire or shield	

 **NOTES**

1. Make sure to disconnect the ABSOCODER sensor from the converter before carrying out insulation checks.
2. If there is a risk that energization may cause damages to the electronic circuits in and around the machine, remove the ABSOCODER sensor from the machine.
3. After completing the checks, short-circuit between the pins to discharge remaining voltage before connecting the ABSOCODER sensor to the converter.

12. CE MARKING

This product conforms to the EMC Directive.

12-1. EMC Directives

It is necessary to do CE marking in the customer's responsibility in the state of a final product.
Confirm EMC compliance of the machine and the entire device by customer because EMC changes configuration of the control panel, wiring, and layout.

12-2. EMC Directive and Standards

EMC consists of emission and immunity items.
It conforms to Table (see below) of EMC standards and Testing.

Class	Standard No.	Standard Name
Emission (EMI)	EN61000-6-4	Generic standards. Emission standard for industrial environments
Immunity (EMS)	EN61000-6-2	Generic standards. Immunity standard for industrial environments
	EN61000-4-2	Electrostatic Discharge
	EN61000-4-3	Radiated, Radio frequency, Electromagnetic Field
	EN61000-4-4	Electrical Fast Transient / Burst
	EN61000-4-5	Surge Immunity
	EN61000-4-6	Conducted Disturbances, Induced by Radio-Frequency Fields
	EN61000-4-8	Power Frequency Magnetic Field

12-3. Low Voltage Directive

This product doesn't apply to low-voltage directive for the equipment of 24VDC power supply.

12-4. Restrictions

In this section, restrictions are described for conforming to the EMC Directive.

- **SSI cable**

Install the clamp filter (accessory) to the SSI cable.

The installation position was set within 300 mm of the host controller.

The shielded SSI cable should be connected to the ground of the converter's power terminal block.

It close to the host controller should be connected to the ground.

- **Sensor cable**

The sensor cable should be covered with the zippertubing with a shield, and the shield should be grounded close to the converter.

Recommendation zippertubing

Model	Manufacturer
MTFS 20 φ	ZIPPERTUBING (JAPAN), LTD.

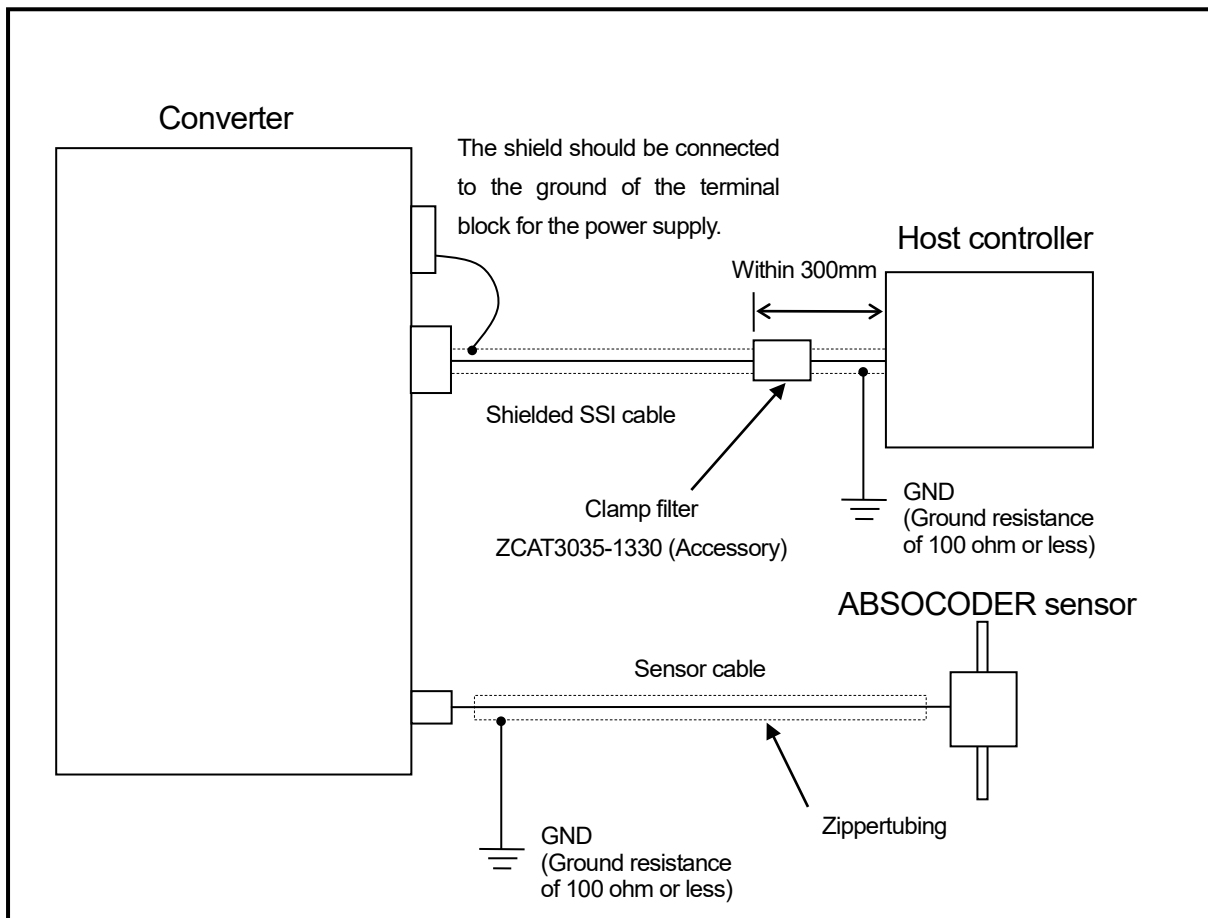



NSD Group

Manufacturer

NSD Corporation 3-31-28, OSU, NAKA-KU, NAGOYA, JAPAN 460-8302

Distributor

NSD Trading Corporation 3-31-23, OSU, NAKA-KU, NAGOYA, JAPAN 460-8302

Phone: +81-52-261-2352 Facsimile: +81-52-252-0522

URL: www.nsdcorp.com E-mail: foreign@nsdcorp.com

Copyright©2021 NSD Corporation All rights reserved.