



ZEF004479404

For Iron and Steel Industry

Abycoder®

**ABSOCODER CONVERTER
NCV-20HBNV2
NCV-20HGNV2**

Specifications & Instruction Manual

Applicable ABSOCODER:
VRE-16TS100



GENERAL SAFETY RULES



(Please read this safety guide carefully before operation)

Thank you very much for purchasing our product. Before operating this product, be sure to carefully read this manual so that you may fully understand the product, safety instructions and precautions.

- Please submit this manual to the operators actually involved in operation.
- Please keep this manual in a handy place.



Signal Words

Safety precautions in this guide are classified into DANGER and CAUTION.

Symbol	Meaning
 DANGER	Incorrect handling may cause a hazardous situation that will result in death or serious injury.
 CAUTION	Incorrect handling may cause a hazardous situation that will result in moderate injury or physical damage.

Instructions accompanied by a symbol  may also result in serious damage or injury. Be sure to follow the all instructions accompanied by the symbol.

Graphic Symbols







Symbol	Meaning
	Indicates prohibited items.
	Indicates items that must be performed to.



Application Limitation

This product is not designed to be used under any situation affecting human life. When you are considering to use this product for special purposes such as medical equipment, aerospace equipment, nuclear power control systems, traffic systems, and etc., please consult with NSD.



This product is designed to be used under the industrial environments categorized in Class A device. The supplier and user may be required to take appropriate measures.

1. Handling Precautions



 DANGER	
	- Do not touch components inside of the controller; otherwise, it will cause electric shock.
	- Do not damage the cable by applying excessive load, placing heavy objects on it, or clamping; otherwise, it will cause electric shock or fire.
	- Turn the power supply OFF before wiring, transporting, and inspecting the controller; otherwise, it may cause electric shock.
	- Provide an external safety circuit so that the entire system functions safely even when the controller is faulty.
	- Connect the grounding terminal of the controller; otherwise, it may cause electric shock or malfunction.

 CAUTION	
	- Do not use the controller in the following places; water splashes, the atmosphere of the corrosion, the atmosphere of the flammable vapor, and the side of the combustibility. Doing so may result in fire or the controller may become faulty.
	- Be sure to use the controller and the ABSOCODER sensor in the environment designated by the general specifications in the manual. Failure to do so may result in electric shock, fire, malfunction or unit failure. - Be sure to use the specified combination of the ABSOCODER sensor, controller and sensor cable; otherwise, it may cause fire or controller malfunction.



2. Storage

 CAUTION	
	- Do not store the controller in a place exposed to water, or toxic gas and liquid.
	- Be sure to store the controller in designed temperature and humidity range, and do not exposed to direct sunlight. - Be sure to consult with NSD when the controller is stored for long periods.



3. Transport



 CAUTION	
	- Do not hold the cable or shaft of ABSOCODER sensor during transport; otherwise, it will cause injury or controller malfunction.

4. Installation



 CAUTION	
	- Do not step on the ABSOCODER sensor or place heavy objects on the controller; otherwise, it will cause injury. - Do not block the exhaust port or allow any foreign matter to enter the controller; otherwise, it will cause fire or unit failure.
	- Be sure to secure the controller and ABSOCODER sensor with the provided brackets; otherwise, it may cause malfunction, injury, or drop. - Be sure to secure the specified distance between the main body and the control panel or other equipments; otherwise, it may cause malfunction.

5. Wiring



 DANGER	
	- Be sure to secure the terminal block firmly; otherwise, it may have risk of fire. - Be sure to mount the terminal cover provided with the controller, before supplying the power, starting operation after the installation, and wiring; otherwise, it may cause electric shock.

 CAUTION	
	- Be sure to keep the sensor cable, control cable, and communication cable at least 300 mm away from the main circuit and power line; otherwise it may cause injury or malfunction. - Be sure to connect all cables correctly; otherwise, it may cause injury or controller malfunction. - Be sure to firmly connect the external I/O connectors and sensor connectors; otherwise, it may cause incorrect inputs and outputs or injury.



6. Operation

 CAUTION	
	- Do not change the controller's function switch settings during the operation; otherwise, it will cause injury. - Do not approach the machine after instantaneous power failure has been recovered. Doing so may result in injury if the machine starts abruptly, it will cause injury.
	- Be sure to check that the power supply specifications are correct; otherwise, it may caused controller failure. - Be sure to provide an external emergency stop circuit so that operation can be stopped with power supply terminated immediately. - Be sure to conduct independent trial runs for the controller before mounting the controller to the machine; otherwise, it may cause injury. - When an error occur, be sure to eliminate the cause, ensure safety, and reset the error before restarting operation; otherwise, it may cause injury.

7. Maintenance And Inspection

 CAUTION	
	- Do not disassemble, remodel, or repair the unit; otherwise, it will cause electric shock, fire, and unit malfunction.
	- The capacitor of the power line deteriorates through prolonged use. We recommended that the capacitor be replaced every five years to prevent secondary damage.

8. Disposal

 CAUTION	
	- Be sure to handle the controller as industrial waste while disposing of it.

* The Document No. appears at the upper right of this manual's cover page.

Document No.	Date	Revision Description
ZEF004479400	21, Dec., 2007	1st Edition Japanese document: ZEF004478801
ZEF004479401	28, Mar., 2008	2nd Edition Japanese document: ZEF004478802 <u>Modification</u> 6-2. Power Supply Connection 6-3. Input / Output Connector Connection
ZEF004479402	17, Jun., 2013	3rd Edition Japanese document: ZEF004478803
ZEF004479403	17, Sep., 2013	4th Edition Japanese document: ZEF004478804
ZEF004479404	19, Feb., 2016	5th Edition Japanese document: ZEF004478805

CONTENTS

- 1. SUMMARY 1
 - 1-1. Features 1
- 2. MODEL SELECTION WHEN ORDERING 2
 - 2-1. Model List 3
- 3. SPECIFICATIONS 4
 - 3-1. Converter Specifications 4
 - 3-2. ABSOCODER Specifications 6
 - 3-3. Extension Sensor Cable Specification 7
- 4. DIMENSIONS 8
 - 4-1. Converter 8
 - 4-2. ABSOCODER 9
 - 4-3. Extension Sensor Cable 10
- 5. INSTALLATION 12
 - 5-1. Converter Installation Conditions and Precautions 12
 - 5-2. ABSOCODER Installation Conditions and Precautions 13
 - 5-3. CE Marking 16
 - 5-3-1. EMC Directives 16
 - 5-3-2. EMC Directive and Standards 16
 - 5-3-3. Measures for EMC Compliance 16
- 6. WIRING 17
 - 6-1. Connection between Converter and ABSOCODER 17
 - 6-1-1. Connection configure of the sensor cable 17
 - 6-2. Power Supply Connection 19
 - 6-3. Input / Output Connector Connection 20
- 7. NOMENCLATURE 22
 - 7-1. Part Identification 22
 - 7-2. Function and Name of Display and Setting Area 22
- 8. OPERATION 23
 - 8-1. Operation Sequence 23
 - 8-2. Position Data "Increase Direction" Setting 24
 - 8-3. Position Data Reading Setting 25
 - (1) Function setting switch list 25
 - (2) Position data reading by LP output 26
 - (3) Position data reading by HOLD (HD) input 27
 - 8-4. Current Position Setting 29
 - (1) For binary code output 29
 - (2) For gray binary code output 30
- 9. MAINTENANCE and INSPECTIONS 31
 - 9-1. Inspection 31
 - 9-2. Troubleshooting 31
- 10. ABSOCODER SENSOR CHECK LIST 32

1. SUMMARY

The NCV-20H Series converter can use with a position detection sensor "ABSOCODER" which has high environment resistance. The durability and reliability is highly improved for iron and steel industry. The position data that ABSOCODER detect by the absolute value is converted to binary or gray binary values for output.

NCV-20HB(G)NV2 converter is used with high resolution VRE (single-turn) type of ABSOCODER.

1-1. Features

(1) Optimum durability and high reliability for iron and steel industry

(2) Using high-resolution VRE (single-turn) type ABSOCODER

NCV-20HB(G)NV2 detects the high-resolution position data that single turn of ABSOCODER divides into 65536 by the absolute format.

(3) High reliability

An absolute position detection format ensures accurate position detection even if a power interruption or unexpected noise condition occurs. An origin returning operation is not required.

(4) Superior durability

NSD's original ABSOCODER is used as the position sensor which features a no-contact construction for excellent durability. This sensor offers problem-free operation, even in environments where it is exposed to vibration, impact shocks, extreme temperatures, oil, and dust.

(5) Compact design

The unit's outside dimensions (39(W) x 155(H) x 93(D)) were miniaturized. Moreover, it is possible to use DIN rail which is easy to mount the converter.

(6) Current position setting function

The position data can be changed as desired by using the control panel's rotary switch. The current position setting is also quick and easy at installation.

(7) A full array of position data reading formats

a) Latch pulse format

Position data reading occurs by synchronizing with the latch pulse signal output from the converter. A position data update cycle (0.2ms, 0.4ms, 12.8ms, 25.6ms, 51.2ms) which is suitable for the host controller's reading speed can be selected.

b) HOLD signal format

A HOLD signal is input to the converter to stop position data output updates, with the position data then being read.

This desired HOLD signal format can be selected from two types:

- A transparent format in which data reading occurs while the HOLD signal is ON.

- A PC synchro format in which position data updates occurs at the HOLD signal's leading or trailing edge.

(8) Error detection function

A sensor disconnected error (SE) is indicated by a monitor "LED". A status output is also provided, enabling reading to a host controller (PLC, etc.).

(9) Compliance with UL and CE standards

The NCV-20H Series complies with both UL (UL508) and CE (EMC Directive) standards, and therefore presents no problems when used in equipment which is to be exported abroad.

(10) Compliance with KC mark (Korea Certification Mark)



The NCV-20H Series complies with KC mark. (It is only certified under the Radio Waves Act of South Korea.) KC mark is the same directives as CE marking. For more details, refer to "5-3. CE Marking".

2-1. Model List

◆ Converter

No.	Model	Descriptions
(1)	NCV-20HBNV2	Position data binary code output (16bit)
	NCV-20HGNV2	Position data gray code output (16bit)

◆ ABSOCODER

No.	Model	Descriptions
(2)	VRE-16TS100[1] K [2][L]-G	<p>Heavy duty type, SUS</p> <p>[1]: Mounting format F: Flange-mount type L: Base-mount type</p>   <p>K: Input shaft (sunk key)</p>  <p>[2]: Connector type B: Standard connector (NJW-2012PM8, manufacturer: Nanaboshi Electric Mfg.Co,Ltd.) R: Crimping terminals (R1.25-4)</p> <p>[L]: Interconnecting sensor cable length (m): 2, 5, 10, 20</p> <p>G: Silicon oil injected, no code: no oil injected</p>

◆ Extension sensor cable

No.	Models	Descriptions
(3)	3S-S-0144-[L]	Standard cable, standard connector
	3S-RBT-0144-[L]	Robotic cable, standard connector
	3P-URT-0144-[L]	Semi-heat-resistant robotic cable, standard connector
(4)	3S-S-4344-[L]	Standard cable, standard connector
	3S-RBT-4344-[L]	Robotic cable, standard connector
	3P-URT-4344-[L]	Semi-heat-resistant robotic cable, standard connector
	3S-HRT-5152-[L]	Heat-resistant robotic cable, standard connector
(5)	3S-S-0190-[L]	Standard cable, crimping terminal
	3S-RBT-0190-[L]	Robotic cable, crimping terminal
	3P-URT-0190-[L]	Semi-heat-resistant robotic cable, crimping terminal
(6)	3S-S-9044-[L]	Standard cable, crimping terminal
	3S-RBT-9044-[L]	Robotic cable, crimping terminal
	3P-URT-9044-[L]	Semi-heat-resistant robotic cable, crimping terminal
	3S-HRT-9052-[L]	Heat-resistant robotic cable, crimping terminal
(7)	3S-S-9090-[L]	Standard cable, crimping terminal
	3S-RBT-9090-[L]	Robotic cable, crimping terminal
	3P-URT-9090-[L]	Semi-heat-resistant robotic cable, crimping terminal
	3S-HRT-9090-[L]	Heat-resistant robotic cable, crimping terminal

(3) Input / Output Specification

Items		Specifications
Input	Input signals	\overline{HD} (Position data HOLD): 1 point
	Input circuit	DC input, photo-coupler isolation
	Input logic	Negative logic
	Rated input voltage	24VDC \pm 10%
	Rated input current	10mA(24VDC)
	ON voltage	10VDC or more
	OFF voltage	4VDC or less
Output	Output signals	$\overline{D0}$ to $\overline{D15}$ (Position data): 16 points \overline{LP} (Latch pulse: position data reading timing): 1 point \overline{SE} , SE (Sensor disconnected error): 2 points
	Output circuit	Isolation, photo-coupler open collector output
	Output logic	$\overline{D0}$ to $\overline{D15}$, \overline{LP} , \overline{SE} :negative logic SE:positive logic
	Rated load voltage	24VDC(30VDC max.)
	Max. load current	$\overline{D0}$ to $\overline{D15}$, \overline{LP} :10mA / point \overline{SE} , SE: 100mA / point
	Max. voltage drop when ON	0.8V

3-2. ABSOCODER Specifications

Items		Specifications
Sensor model		VRE-16TS100
Total number of turns		1
Number of divisions		65536 (2^{16})
Mass		$8.5+0.15 \times \text{cable length (m)}$ kg
Linearity error		0.084° Max.
Moment of inertia $GD^2/4(J)$		$4.1 \times 10^{-5} \text{ kg-m}^2$ ($4.2 \times 10^{-4} \text{ kgf-cm-s}^2$)
Starting torque		$9.8 \times 10^{-2} \text{ N-m}$ or less (1 kgf-cm or less)
Permissible shaft load	Radial	$1.5 \times 10^2 \text{ N}$ (15kgf)
	Thrust	78N (8kgf)
Permissible mechanical speed		4000r/min
Bearing life		$8 \times 10^4 \text{ h}$ (at 4000r/min)
Ambient temperature	Operating	-20~+120°C
	Storage	-30~+120°C
Vibration resistance		$2.0 \times 10^2 \text{ m/s}^2$ (20G) 200Hz, up/down 4 h, forward/back 2 h, conforms to JIS D 1601 standard
Shock resistance		$4.9 \times 10^3 \text{ m/s}^2$ (500G) 0.5 ms, up/down/forward/back X 3 times each, conforms to JIS C 5026 standard
Protection rating		IP67, conforms to JEM 1030 standard
Max. sensor cable length	3S-S	200m
	3S-RBT/URT /HRT	100m
Surface treatment		Not treated
Material		Stainless

3-3. Extension Sensor Cable Specification

Items	Specifications			
Model code	3S-S	3S-RBT	3P-URT	3S-HRT
Cable type	Standard cable	Robotic cable	Semi heat-resistant robotic cable	Heat-resistant robotic cable
Diameter	$\phi 8$			$\phi 9.5$
Operating temperature range	-5 to +60°C		-5 to +105°C	0 to +150°C
Insulator	Irradiated cross linked foamed polyethylene	ETFE plastic		
Sheath	Polyvinyl chloride mixture		Heat-resistant polyvinyl chloride mixture	Fleonex
Construction	7-core, 1-triple without shield + 2 pairs with shield			
Color of sheath	Dark brown	Blue		Black
Advantage	Extensible for long distances	Superior flexibility; ideal for moving place		Heat treatment and flexibility; ideal for moving place

[Remark]

Contact your NSD representative when the extension cable combines different types of cables.

4. DIMENSIONS

4-1. Converter

Units: mm

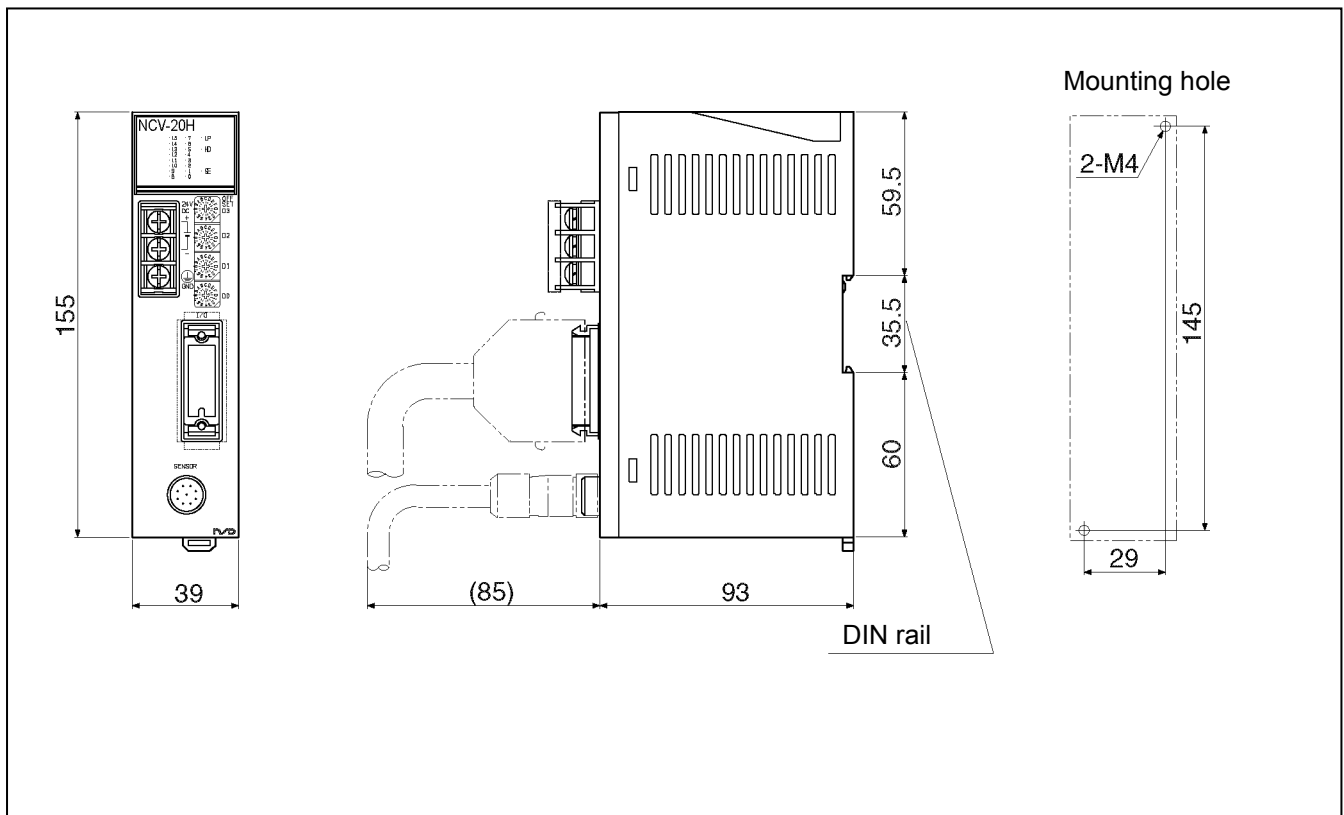

4-2. ABSOCODER

(1) VRE-16TS100FK[][]-G (Flange-mount type)

Units: mm

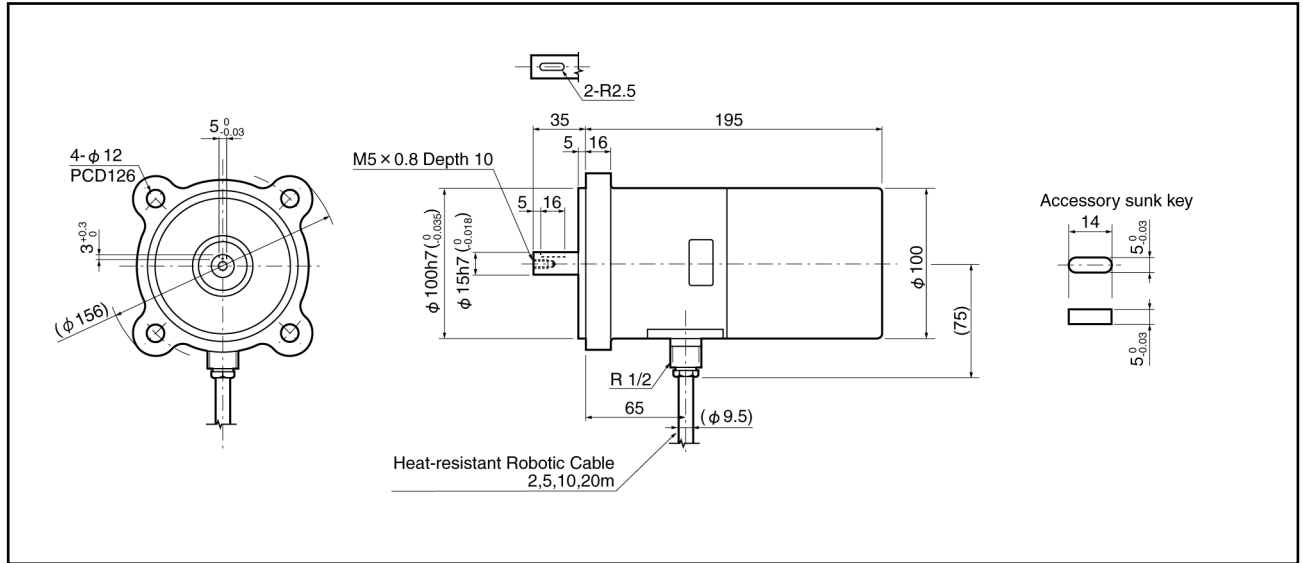

(2) VRE-16TS100LK[][]-G (Base-mount type)

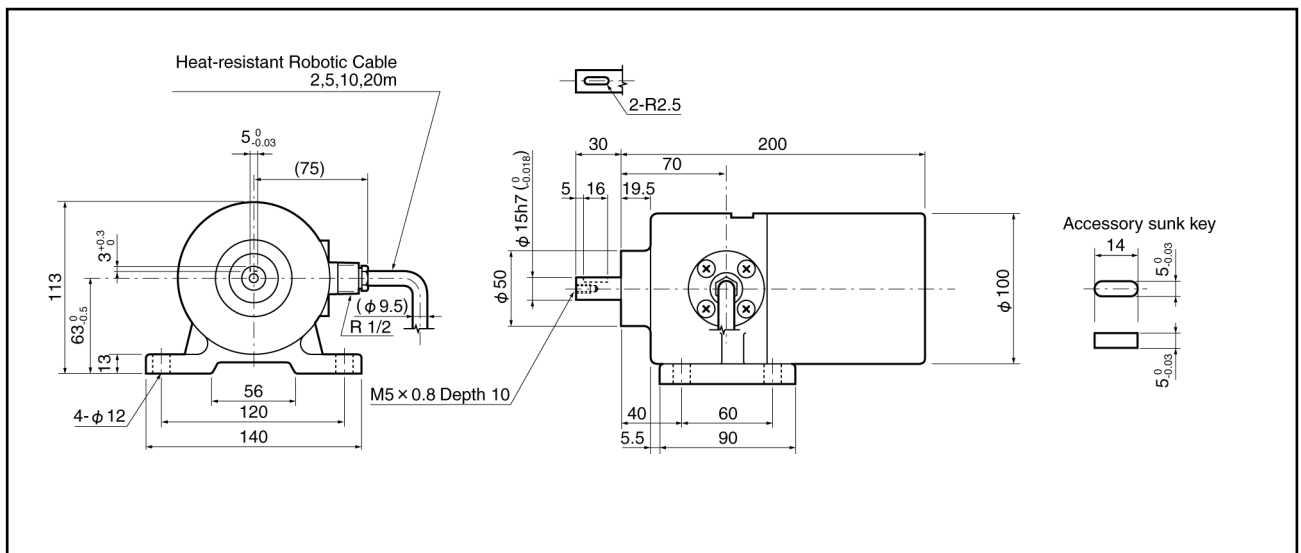

4-3. Extension Sensor Cable

(1) 3S-S-0144-[L] / 3S-RBT-0144-[L] / 3S-URT-0144-[L]

Units: mm

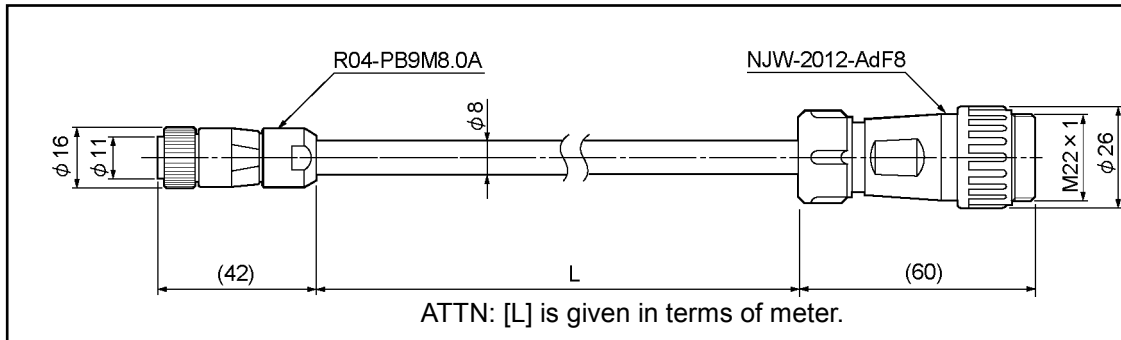

(2) 3S-S-4344-[L] / 3S-RBT-4344-[L] / 3S-URT-4344-[L]

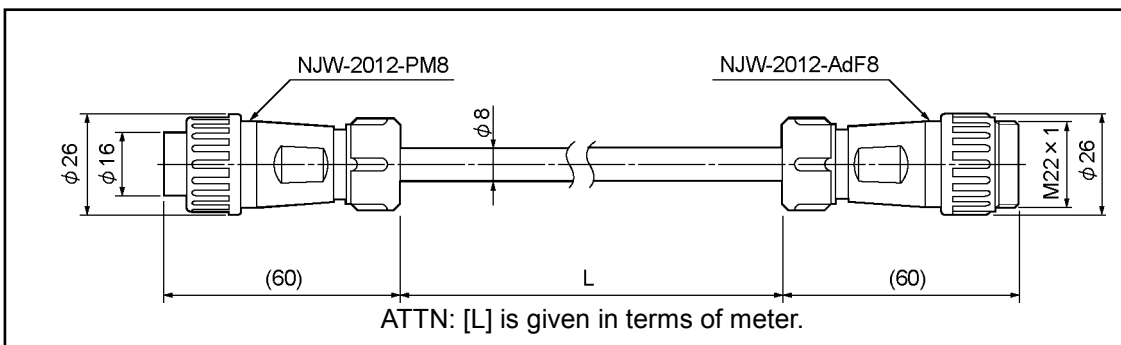

(3) 3S-HRT-5152-[L]

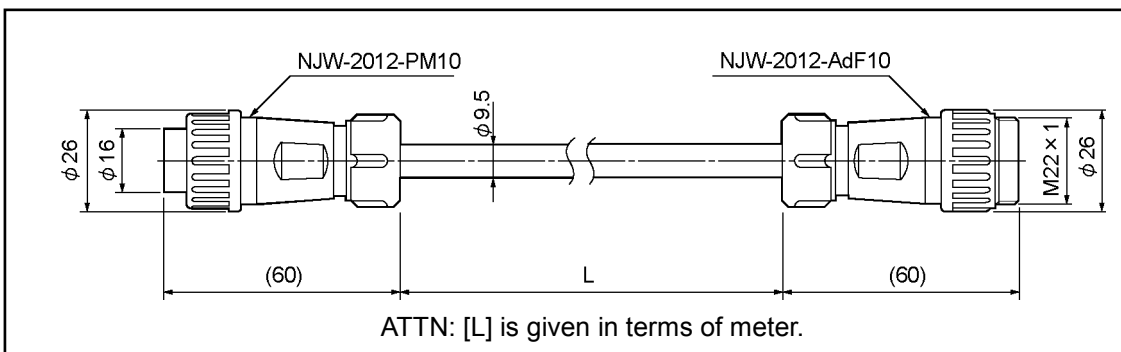

(4) 3S-S-0190-[L] / 3S-RBT-0190-[L] / 3S-URT-0190-[L]

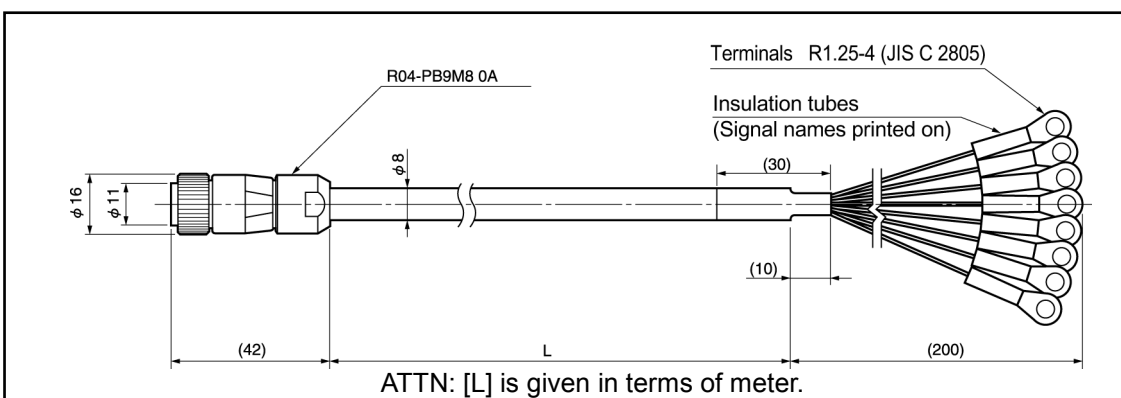

(5) 3S-S-9044-[L] / 3S-RBT-9044-[L] / 3S-URT-9044-[L]

Units: mm

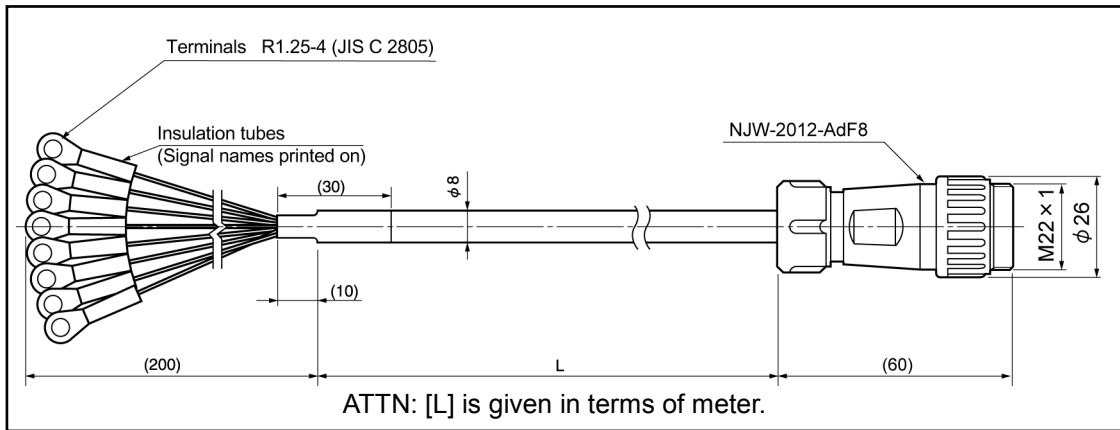

(6) 3S-HRT-9052-[L]

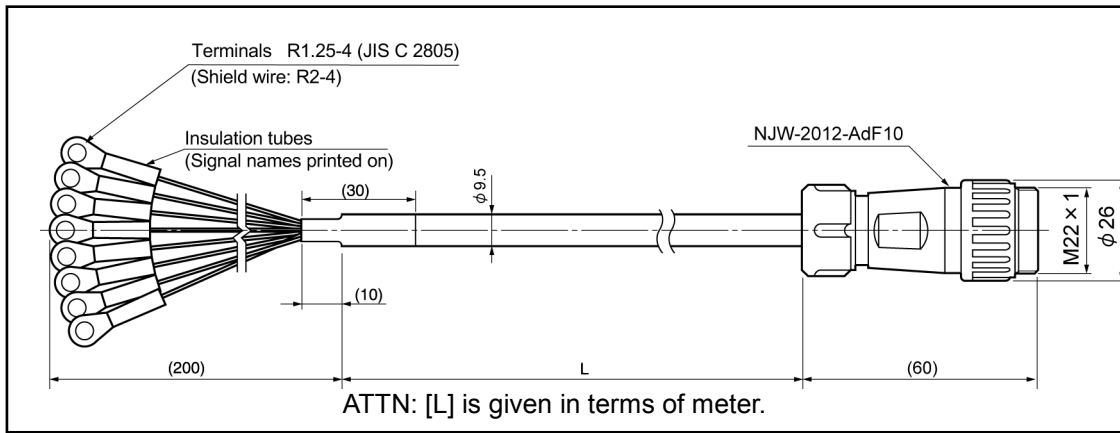

(7) 3S-S-9090-[L] / 3S-RBT-9090-[L] / 3S-URT-9090-[L]

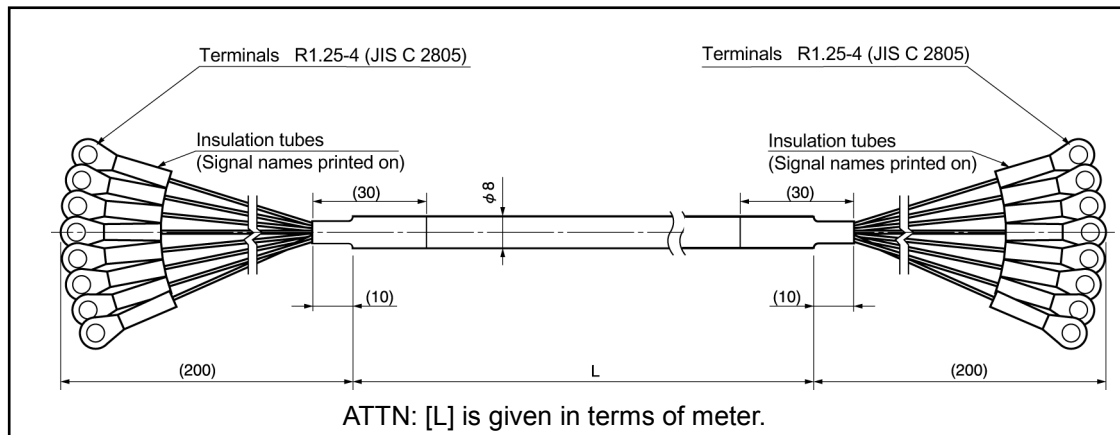

(8) 3S-HRT-9090-[L]

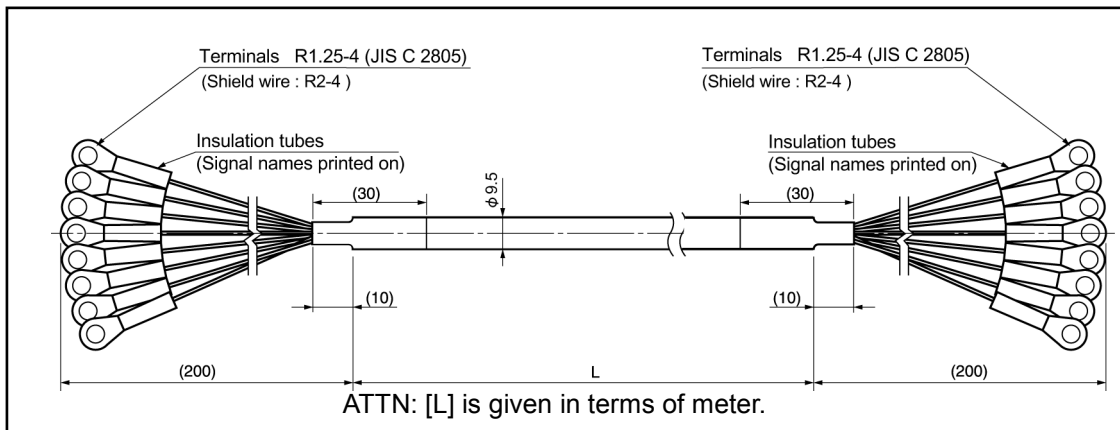

5. INSTALLATION

The installation conditions and precautions for each of the system components are described in this section.

5-1. Converter Installation Conditions and Precautions

-Installation Site

- (1) Avoid sites where the unit is exposed to direct sunlight.
- (2) The ambient temperature should never exceed a 0 to 55°C range.
- (3) The ambient humidity should never exceed a 20 to 90% RH range.
- (4) Do not install the unit in areas where condensation is likely to occur (high humidity with extreme temperature changes).
- (5) Avoid sites where dust is excessive.
- (6) Do not install in areas with an excessive amount of salt and/or metal chips.
- (7) Do not install in areas where flammable and/or corrosive gases are present.
- (8) Avoid areas where splashing water, oil or chemicals are likely to occur.
- (9) Avoid areas where vibration and shocks are excessive.

-Installation cautions

- (1) Install inside the control cabinet.
- (2) Install in a vertical direction so that the characters are visible.
- (3) If a DIN rail mounting format is used, insert until the latch mechanism catches with an audible click.
Secure between end plates at both sides.
- (4) In high vibration areas, secure tightly with 2 M4 screws.
- (5) Install as far from high voltage lines and power lines as possible in order to minimize noise influences.
- (6) Allow 85mm or more space at the converter's front side for plugging in and unplugging the connector.
- (7) Peripheral components should be arranged so as not to obstruct converter installation, removal, and connector plugging/unplugging.
- (8) Peripheral components should be arranged so as not to obstruct the converter's heat dissipation.

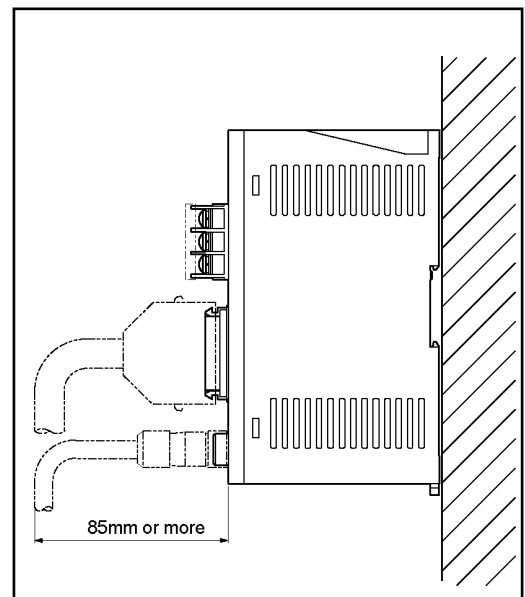

5-2. ABSOCODER Installation Conditions and Precautions

The installation conditions and precautions for ABSOCODER are described in this section.

-Handling of Turn-type ABSOCODER

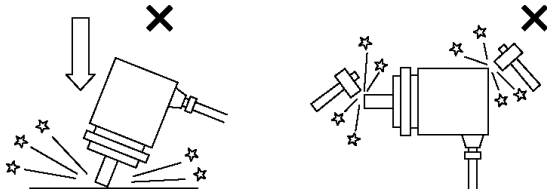
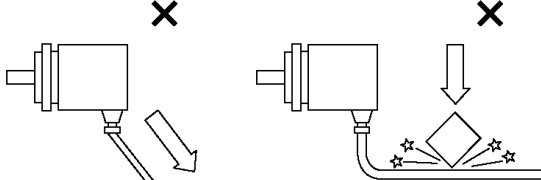
Item	Explanation
1) Main unit	<p>Never drop the Sensor, or subject it to excessive forces or shocks.</p> 
2) Cable	<p>Avoid stepping on, or applying excessive stress to the cable.</p> 

-Mounting of Turn-type ABSOCODER

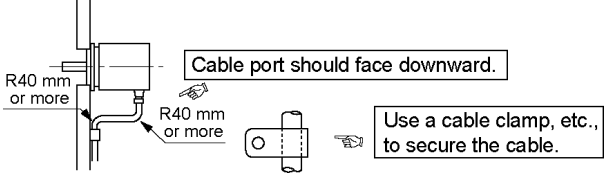
Item	Explanation	Precaution
1) Mounting	For details regarding mounting dimensions, refer to each sensor dimensions.	
2) Cable port	<p>Cable port should face downward.</p> 	

-Mounting of Turn-type ABSOCODER

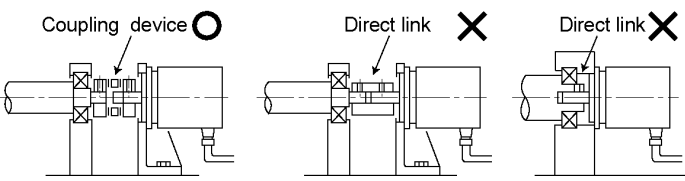
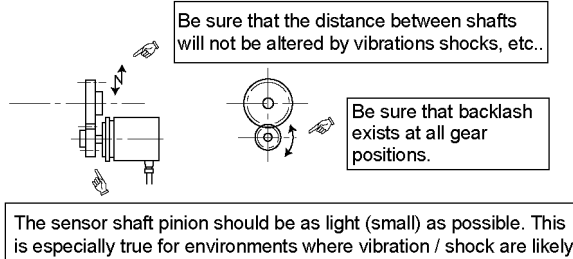
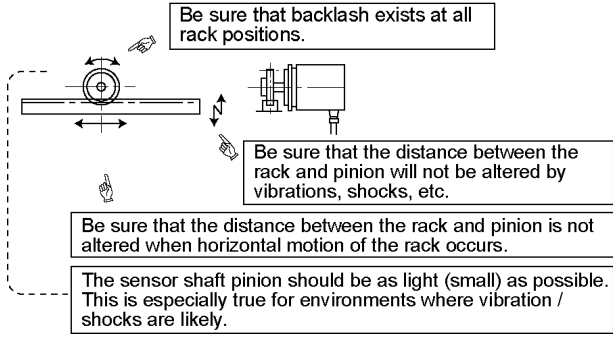
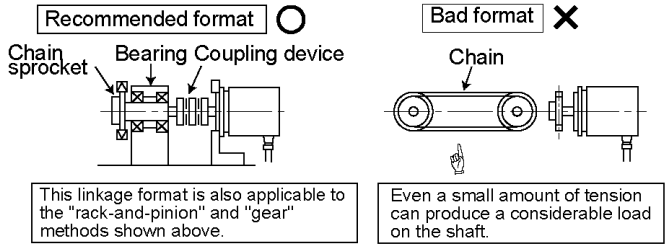
Item	Explanation	Precaution
<p>1) Coupling of machine shaft and sensor shaft</p>	<p>Be sure to use a coupling device to link the 2 shafts.</p> 	<p>A "direct-link" format will result in shaft fatigue and / or breakage after long periods. Therefore, be sure to use a coupling device to link the shafts.</p>
<p>2) For gear-type linkage</p>	<p>If a gear linkage is used, be sure that some backlash exists.</p> 	<p>Incorrect gear mounting can result in shaft bending or breakage.</p>
<p>3) For rack and pinion type linkage</p>	<p>Be sure that backlash exists at all rack positions.</p> 	<p>Incorrect rack and pinion mounting can result in shaft bending or breakage.</p>
<p>4) Chain or timing belt linkage</p>	<p>When a chain or timing belt linkage format is used, there is an inherent risk of the shaft's load being increased by the resulting tension. Therefore, a bearing should be used, with the shafts being linked by a coupling device immediately behind the bearing.</p> 	

Mounting of Turn-type ABSOCODER

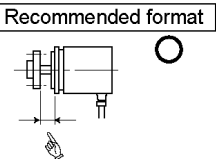
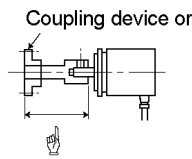
Item	Explanation	Precaution
5) Shaft mounting position	<p>The shaft should be attached to the coupling device or gear at a point which is as near to the sensor body as possible.</p> <div style="display: flex; justify-content: space-around;"> <div style="text-align: center;"> <p>Recommended format</p>  <p>This distance should be as short as possible. When this distance is short, the load placed on the bearing by vibrations / shocks is slight.</p> </div> <div style="text-align: center;"> <p>Bad format</p> <p>×</p>  <p>Never use an extended shaft format.</p> </div> </div>	

-Coupling of Turn-type ABSOCODER

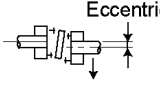
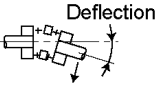
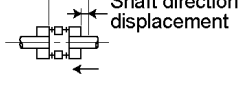
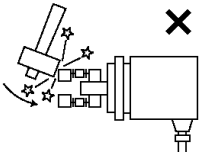
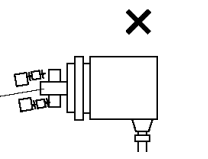
Item	Explanation	Precaution
1) Coupling device selection precaution	<p>1. When selecting a coupling, consider factors such as the design mounting error, the coupling tolerance error, and the sensor's permissible shaft load.</p> <div style="display: flex; justify-content: space-around;"> <div style="text-align: center;"> <p>Mounting error < Coupling tolerance error</p>  <p>Load produced by eccentric condition.</p> </div> <div style="text-align: center;"> <p>Deflection</p>  <p>Load produced by deflection.</p> </div> <div style="text-align: center;"> <p>Prescribed dimension < Sensor shaft load</p> <p>Coupling shaft permissible load < Sensor shaft load</p>  <p>Force produced by shaft direction displacement.</p> </div> </div> <div style="display: flex; justify-content: space-around; margin-top: 10px;"> <div style="text-align: center;"> <p>Radial load</p> </div> <div style="text-align: center;"> <p>Thrust load</p> </div> </div> <p>2. If the selected coupling device is larger than necessary (when used in high vibration/shock environments), the load which is applied to the shaft by the vibrations/shocks will be increased by the weight of the coupling device.</p> <p>3. Be sure to select a coupling device with an adequate transmission torque surplus relative to the sensor shaft's torque.</p>	<p>The selection of a larger coupling than necessary will increase the shaft load which is caused by the mounting error amount. Excessive force applied to the shaft can deform the coupling and reduce durability.</p>
2) Coupling device installation precaution	<p>Avoid bending or damaging the coupling.</p> <div style="display: flex; justify-content: space-around; margin-top: 10px;"> <div style="text-align: center;"> <p>×</p>  </div> <div style="text-align: center;"> <p>×</p>  </div> </div>	

5-3. CE Marking

NCV-20H series conforms to CE Marking (EMC directive), but stands outside scope of the low voltage directive because it is 24 VDC power apparatus.

5-3-1. EMC Directives

It is necessary to do CE marking in the customer's responsibility in the state of a final product.

Confirm EMC compliance of the machine and the entire device by customer because EMC changes configuration of the control panel, wiring, and layout.

5-3-2. EMC Directive and Standards

EMC Directive consists of immunity and emission items.

It conforms to Table 01(see below) of EMC standards and Testing.

Table 01 EMC Standard and Testing

Class	Standard No.	Name
EMI (Emission)	EN61000-6-4	Generic standards. Emission standard for industrial environments
	EN55011 Class A	Electromagnetic radiation disturbance
EMS (Immunity)	EN61000-6-2	Generic standards. Immunity standard for industrial environments
	EN61000-4-2	Electrostatic discharge
	EN61000-4-3	Radiated, radio frequency, electromagnetic field
	EN61000-4-4	Electrical fast transient / burst
	EN61000-4-5	Surge immunity
	EN61000-4-6	Conducted disturbances, induced by radio-frequency fields
	EN61000-4-8	Power frequency magnetic field

5-3-3. Measures for EMC Compliance

The I / O cable must be under 30m from the host controller to the converter. The wiring should be surely secured.

[Reference]

It may be improved when clamp ferrite core is added to the power supply cable, sensor cable, and I/O cable when it operates faultily by the influence from the peripheral device.

Recommendation Clamp Ferrite Core (Product name: Clamp filters for cable)

Mounting location	Clamp ferrite core model	Manufacturer
Power supply cable, sensor cable	ZCAT2032-0930 (Inner dimensions: ϕ 9)	TDK
I / O cable	ZCAT3035-1330 (Inner dimensions: ϕ 13)	TDK

6. WIRING

6-1. Connection between Converter and ABSOCODER

The maximum extension sensor cable length varies according to the ABSOCODER sensor and cable model being used. Please refer to the 3-2 for details.

-Wiring Precautions

- (1) The sensor cable should be clamped as shown in the right figure to prevent excessive tension from being applied to the cable connectors.
- (2) The sensor cable should be located at least 300mm away from power lines and other lines which generate a high level of electrical noise.
- (3) If the cable is moved under the state of bending like a horseshoe, a robotic cable should be used. The bend radius should never be less than 75 mm.

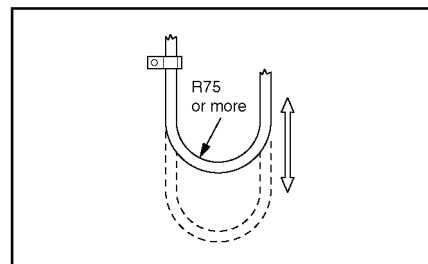
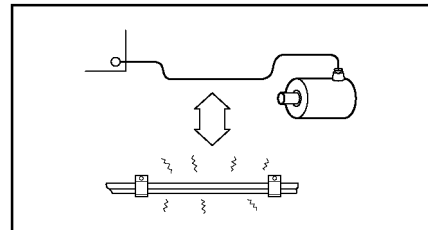
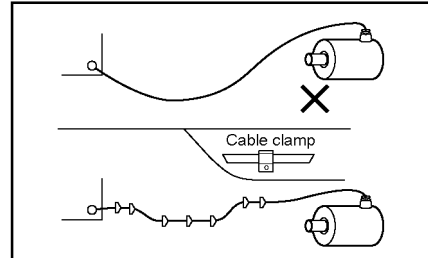

6-1-1. Connection configure of the sensor cable

Indicates the connection figure when using the sensor cable.

(1) In the case of connecting by the connector

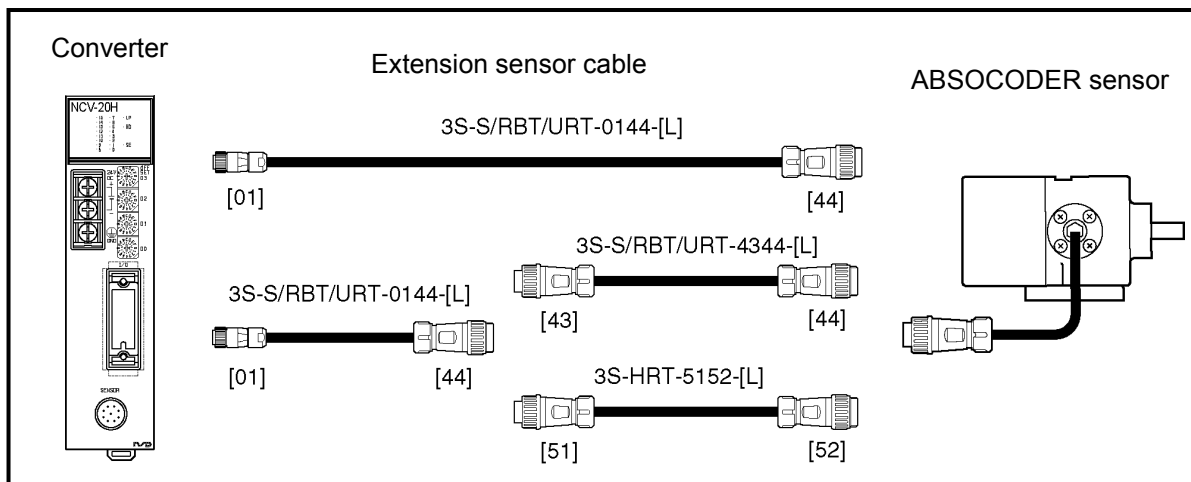

(2) In the case of connecting by the crimping terminal

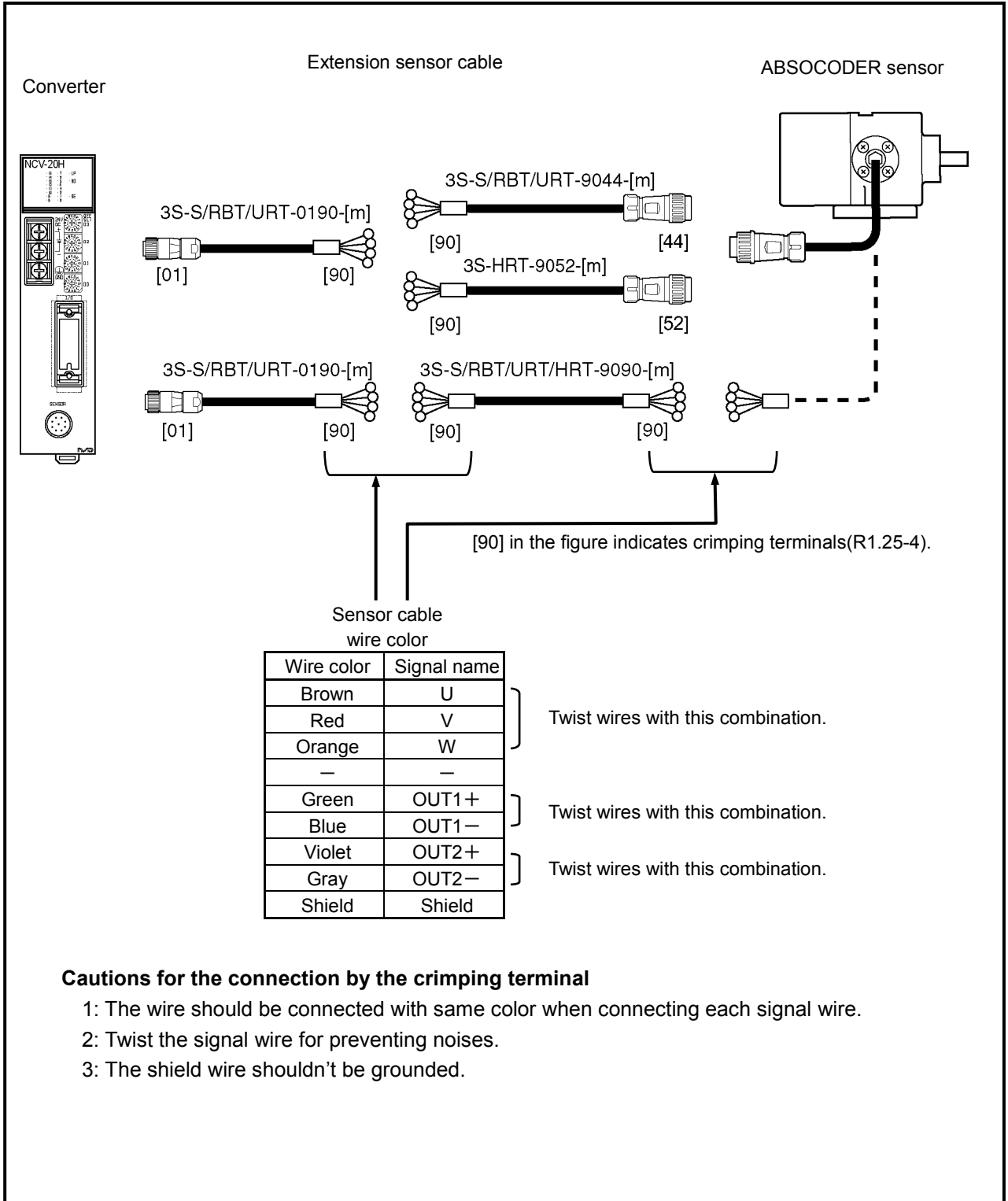

Cautions for the connection by the crimping terminal

- 1: The wire should be connected with same color when connecting each signal wire.
- 2: Twist the signal wire for preventing noises.
- 3: The shield wire shouldn't be grounded.

6-2. Power Supply Connection

The power supply should be connected as described below:

(1) Power Supply

-The rush current is 10A(rush time of 20ms), so select the power supply after due consideration. Choose the capacity of the power supply over double of power consumption of converter.

-The input power supply should be isolated from the commercial power supply.

-Twist the power cable for preventing noises.

-Use the M4 size crimp lug terminals with insulating sleeves in order to prevent short circuit caused by loose screws.

-Use a Class 2 power supply.

-Use AWG 12 to 22 electrical wires which conform to the UL1015 or UL1007 standard.

-Use field installed conductors with a temperature rating of 75°C or higher.

-Use electrical wires of copper or copper strand.

-The terminal block tightening torque is 1.8 N·m (16 lb·in).

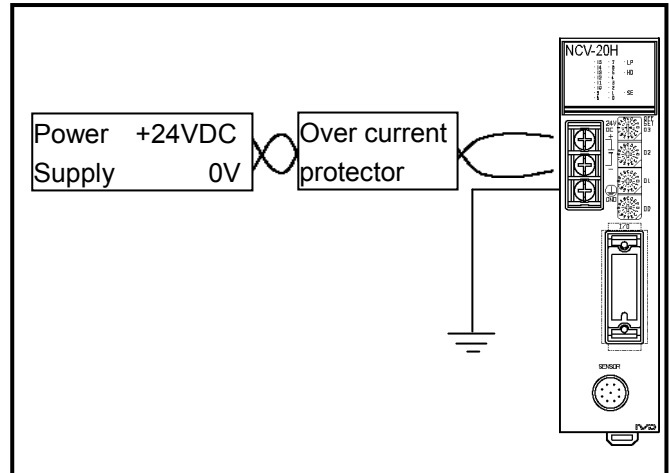

(2) Ground

-The unit should be securely grounded (ground resistance of 100ohm or less) to prevent electrical shocks.

-The ground wire should be connected to the ground terminal directly.

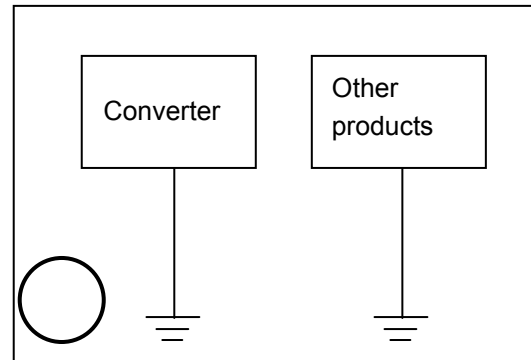
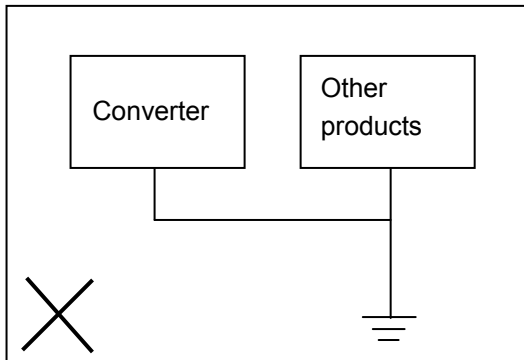

-Use AWG 12 to 14 electrical wires which conform to the UL1015 or UL1007 standard.

-Use field installed conductors with a temperature rating of 75°C or higher.

-Use electrical wires of copper or copper strand.

-The terminal block tightening torque is 1.8 N·m (16 lb·in).

6-3. Input / Output Connector Connection

Lead wires should be soldered to pins of the connector according to the I/O chart below.

Pin No.	Signal Names	Input / Output	Descriptions
1	$\overline{D0}$	Output	NCV-20HBNV2: Output the position data by 16 bit of binary code. NCV-20HGNV2: Output the position data by 16 bit of gray binary code. $\overline{D0}$: LSB (Least Significant Bit) $\overline{D15}$: MSB (Most Significant Bit)
2	$\overline{D1}$		
3	$\overline{D2}$		
4	$\overline{D3}$		
5	$\overline{D4}$		
6	$\overline{D5}$		
7	$\overline{D6}$		
8	$\overline{D7}$		
9	$\overline{D8}$		
10	$\overline{D9}$		
11	$\overline{D10}$		
12	$\overline{D11}$		
13	$\overline{D12}$		
14	$\overline{D13}$		
15	$\overline{D14}$		
16	$\overline{D15}$		
17	NC		Do not connect anything.
18	SE	Output	Switches OFF when sensor or connector is disconnected or loose.
19	\overline{SE}		Switches ON when sensor or connector is disconnected or loose.
20	Z24	Input	Ground for sensor disconnected error output signal
21	P24		This is a power supply for the sensor disconnected error output and HOLD input signals.
22	\overline{HD}		The HOLD input signal is used to HOLD position data outputs from the host controller.
23	\overline{LP}	Output	Outputs the position data reading timing signal.
24	SG	Input	Ground for $\overline{D0}$ to $\overline{D15}$, and \overline{LP} signals
25	SG		

Connector at cable side (It is included in the converter.)

Soldered socket: MR-25F

Cover: MR-25L

Connectors are manufactured by Honda Tsushin Kogyo Co., LTD.

Pin arrangement

Connector model :
MR-25F

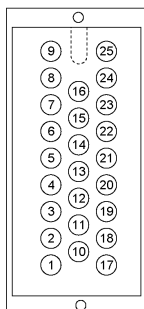

Viewed from the soldered terminals on the rear side of the connector.

● I/O Circuit

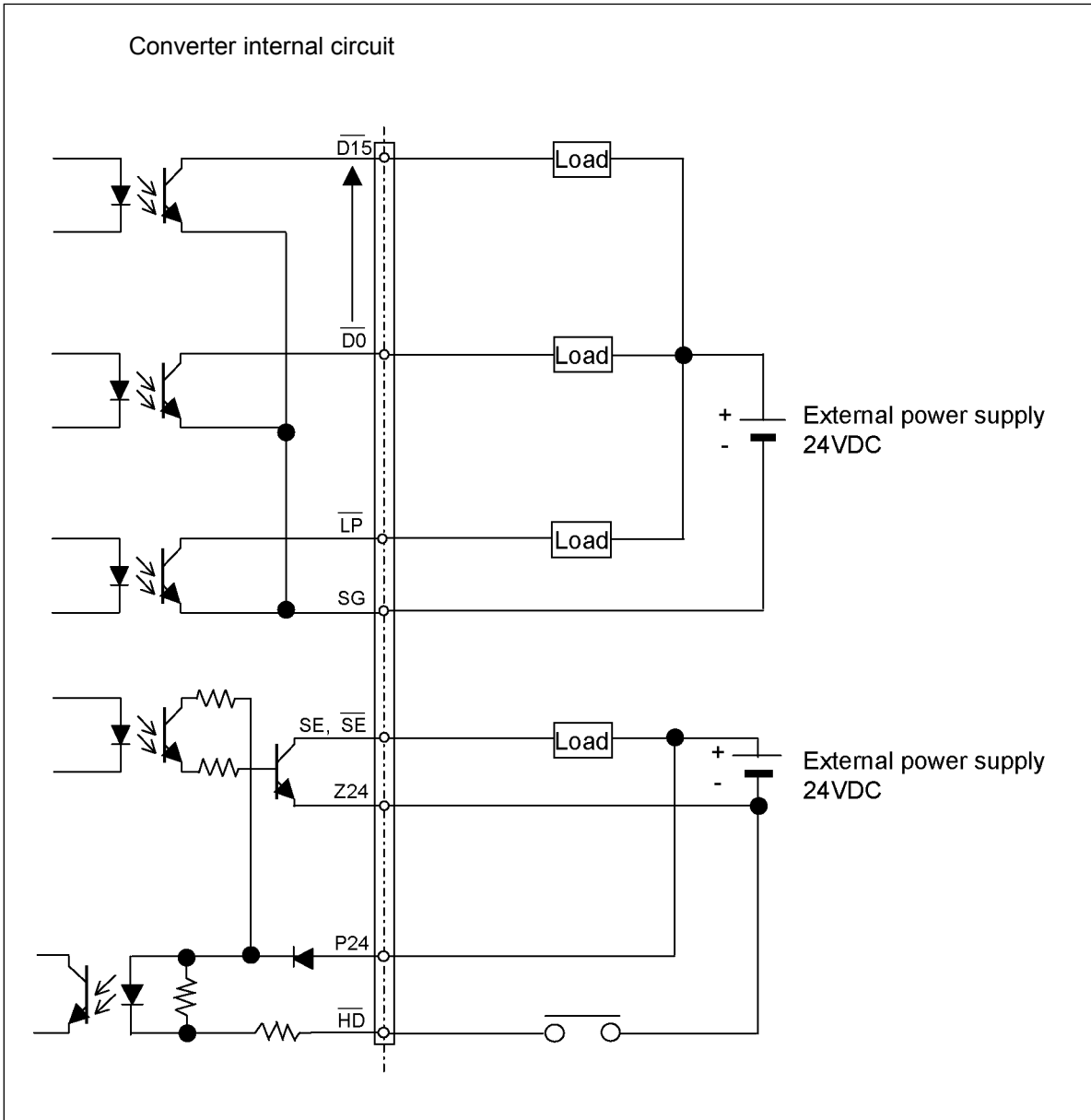

*1 Input/output circuit is isolated from power supply and internal circuitry by photo-coupler.

*2 Use a Class 2 power supply for the input/output external power supply.

7. NOMENCLATURE

7-1. Part Identification

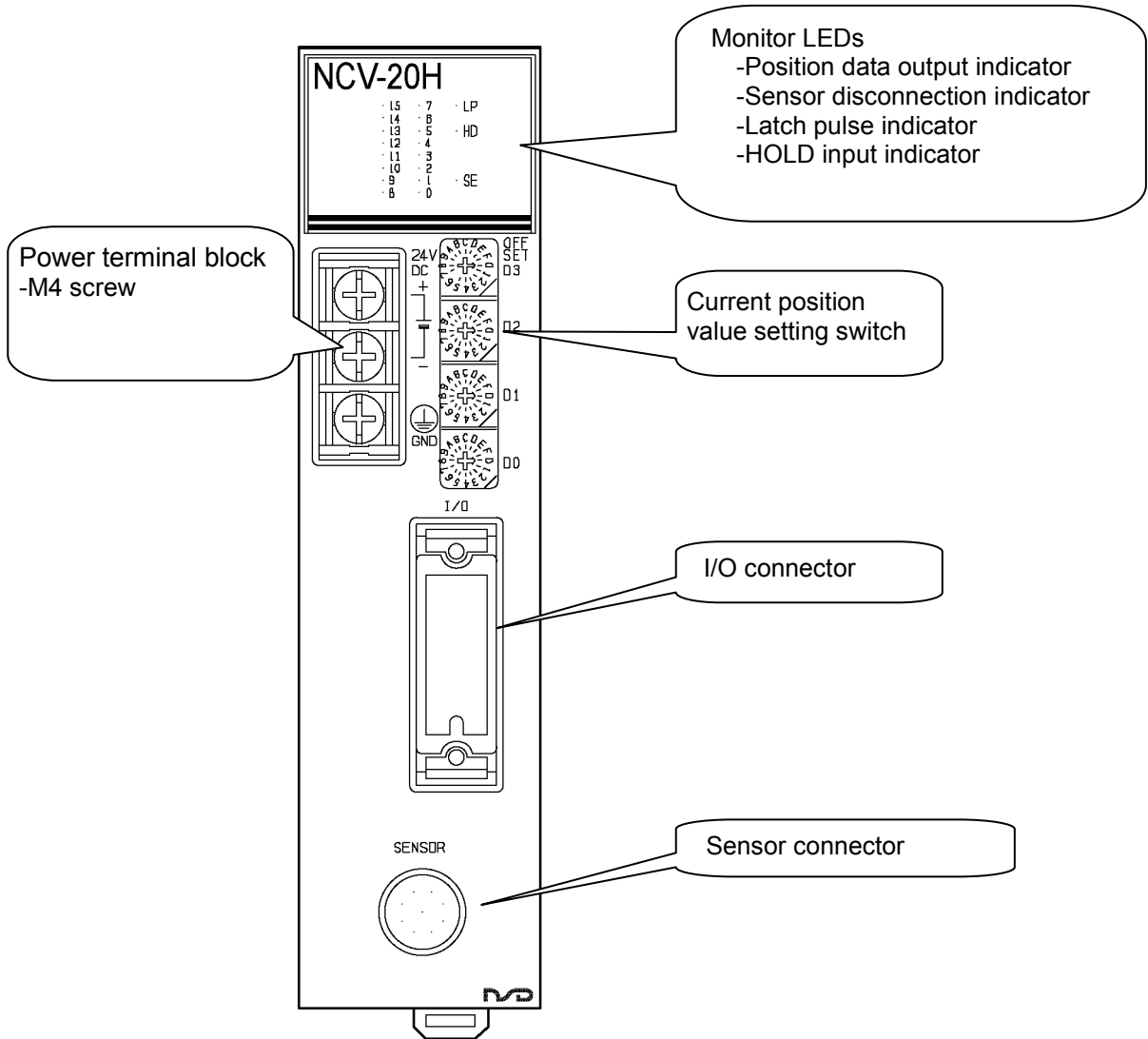

7-2. Function and Name of Display and Setting Area

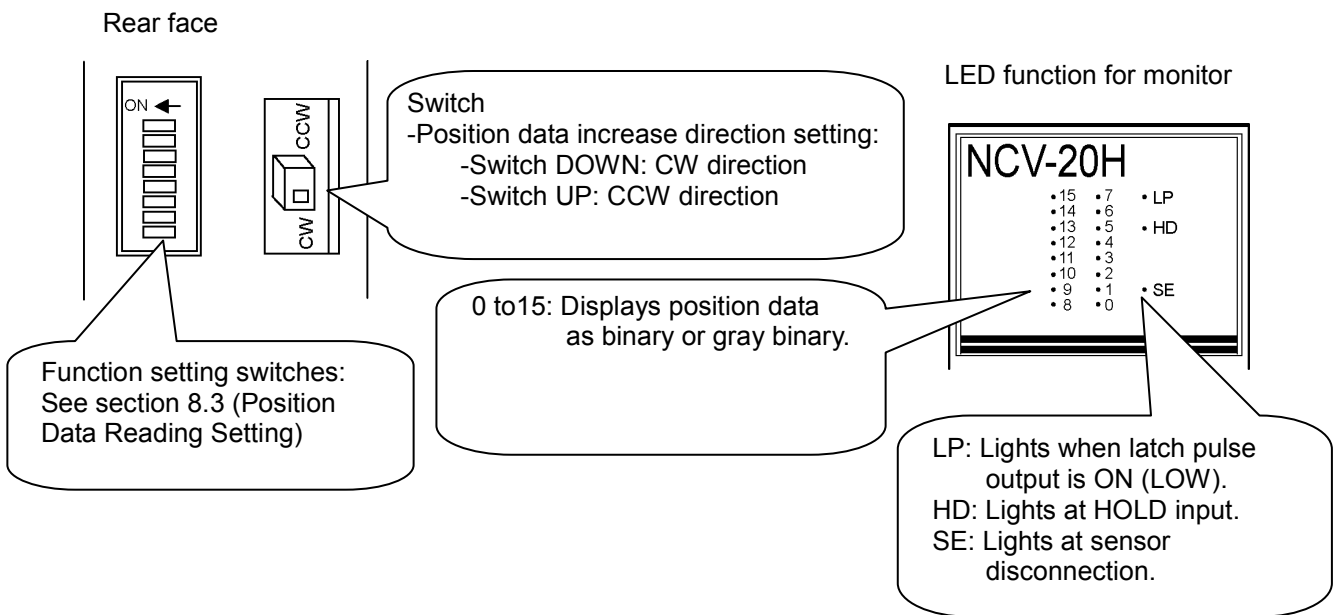

8. OPERATION

8-1. Operation Sequence

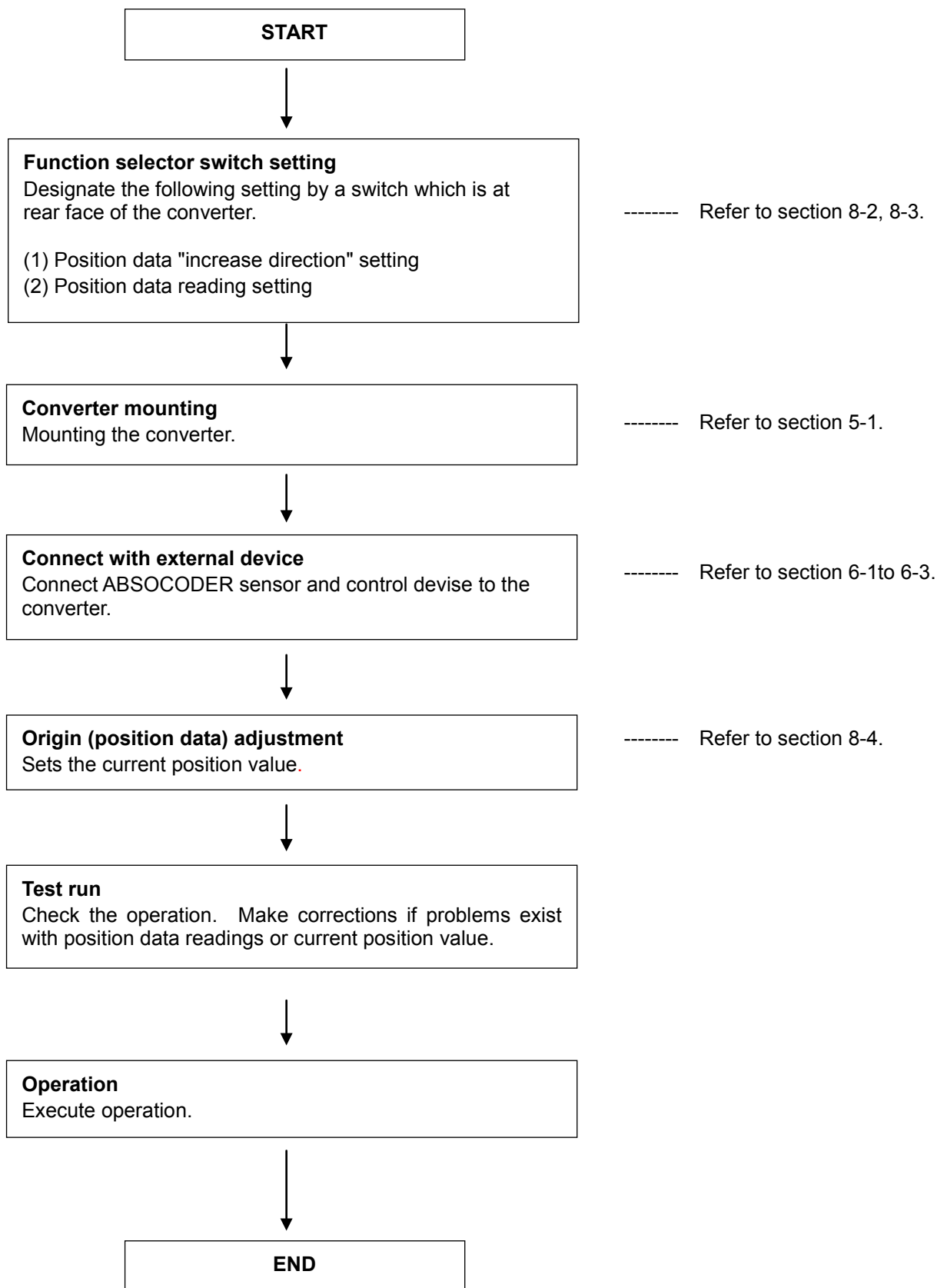

8-2. Position Data "Increase Direction" Setting

The position data increases or decreases according to the ABSOCODER sensor's rotative direction. The direction in which the position data increases is specified by a switch on the converter's rear face.

Switch setting

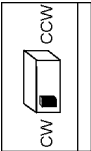
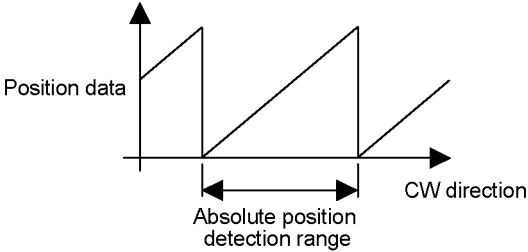
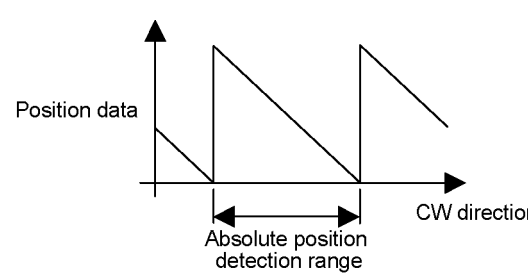
Switch setting	Increase direction	Alteration of the position data
Switch DOWN position ("CW" side)  Factory setting	CW	
Switch UP position ("CCW" side)	CCW	

Rotative direction of the shaft

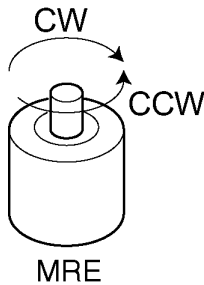

Important

Position data "increase direction" setting caution

Do not change the position data "increase direction" switch setting while the power is ON, as this could cause an accident.

8-3. Position Data Reading Setting

(1) Function setting switch list

The following two position data reading formats are available:

- 1) Latch pulse (LP) format...Reads position data which is updated regularly in synchronization with a latch pulse output signal from the converter.
 - 2) HOLD (HD) format...Reads position data while position data updates are stopped by a HOLD input signal. When the LP output signal reading format is used, a position data update period (cycle) can be selected which is appropriate for the host controller being used.
- When the HD input signal reading format is used, either a transparent format or a PC synchro format can be selected.

The desired position data reading format can be specified by the DIP switches on the rear face of the converter. The DIP switch settings are shown below.

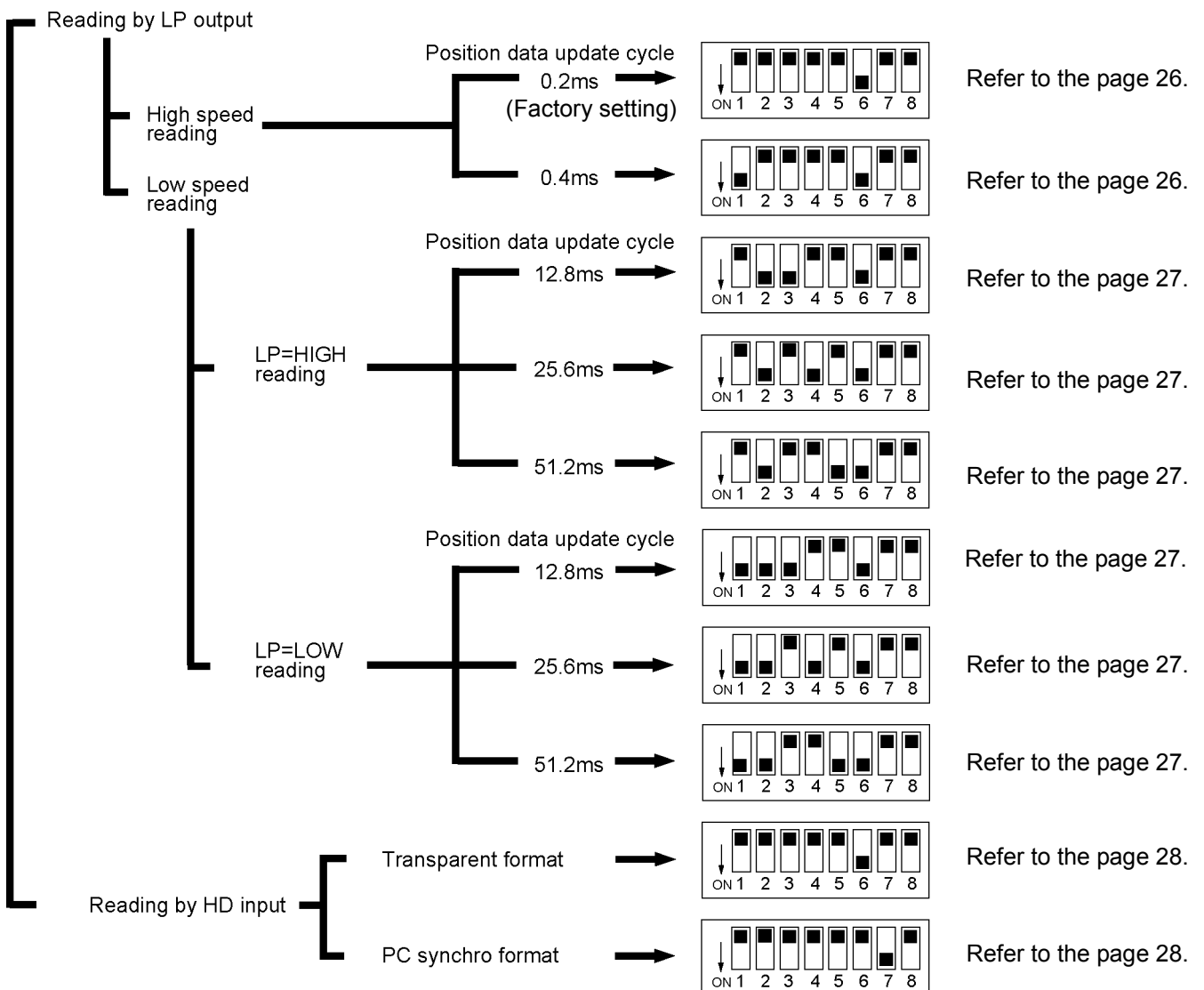

Important

Cautions when using the function setting switches

- Always verify the function setting switch settings before beginning operation.
- Never use function switch settings which are not indicated in the specifications.
- Do not change function switch settings during operation, as this could result in injury.

(2) Position data reading by LP output

Position data reading is synchronized with the LP output signal from the converter. Either high-speed or low-speed reading can be selected.

● High-speed reading

When high-speed reading is selected, the position data output stabilizes at the trailing edge of the LP output signal. The position data should be read at that time.

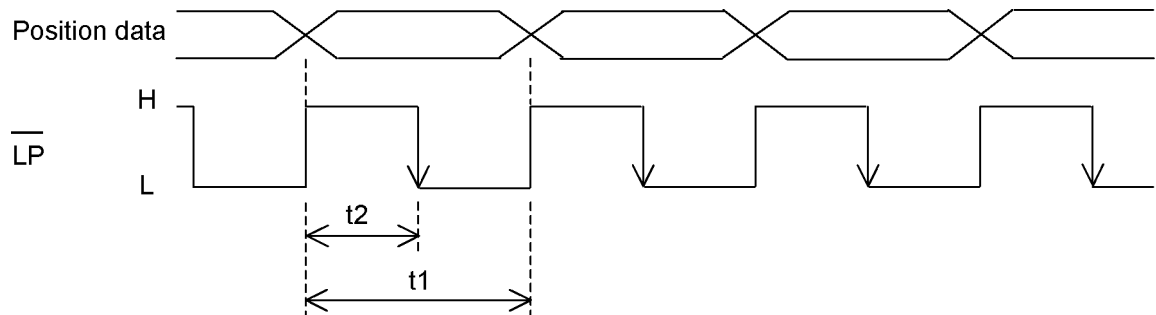

LP cycle	Switch setting	t_1	t_2
0.2ms		200 μ s	70 to 100 μ s
0.4ms		400 μ s	170 to 200 μ s

● **Low-speed reading (at LP=HIGH)**

When low-speed reading (at LP=HIGH) is selected, the position data output stabilizes when the LP output signal is HIGH. The position data should be read at that time.

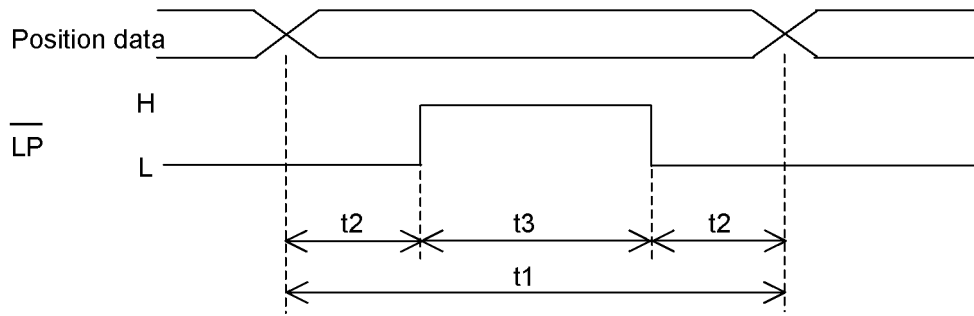

Position data update cycle	Switch setting	t1	t2	t3
12.8ms		12.8ms	3.2ms	6.4ms
25.6ms		25.6ms	6.4ms	12.8ms
51.2ms		51.2ms	12.8ms	25.6ms

● **Low-speed reading (at LP=LOW)**

When low-speed reading (at LP=LOW) is selected, the position data output stabilizes when the LP output signal is LOW. The position data should be read at that time.

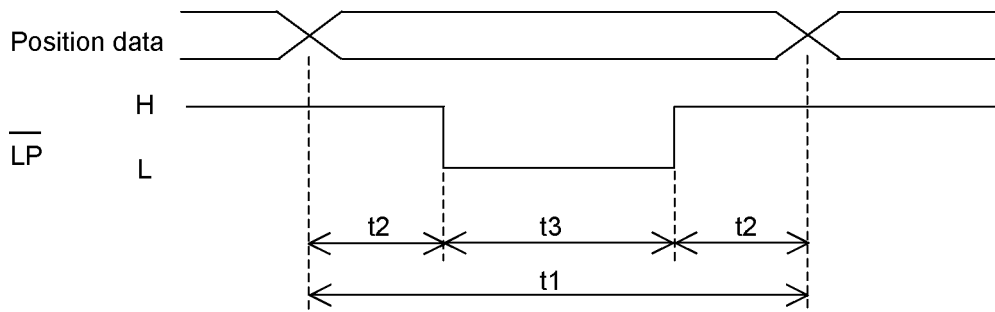

Position data update cycle	Switch setting	t1	t2	t3
12.8ms		12.8ms	3.2ms	6.4ms
25.6ms		25.6ms	6.4ms	12.8ms
51.2ms		51.2ms	12.8ms	25.6ms

(3) Position data reading by HOLD (HD) input

The HD input signal is used to HOLD position data outputs from the host controller. Either of the following 2 position data HOLD formats can be selected.

● **Transparent format**

Position data output updating is stopped by an HD input signal from the host controller (PLC, etc.). The position data should be read at that time.

Updating of the position data is stopped while the HD input signal is ON (L). Position data reading should be performed after waiting period "t1" following the HD input signal ON.

When the HD input signal switches OFF (H), position data updates are synchronized with the LP output signal.

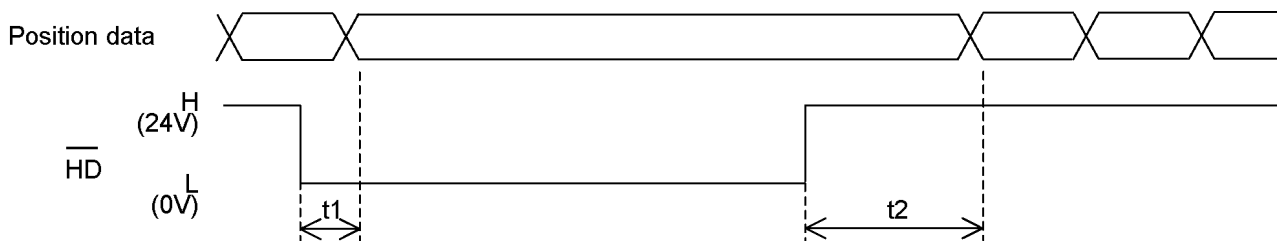

	Switch setting	t1	t2
Transparent format		90μs	340μs

● **PC synchro format**

Position data output updating occurs when the HD input signal status changes (leading edge or trailing edge), and is not synchronized with the LP output signal.

Position data reading should be performed following waiting period "t1" after the HD input signal status is changed by the host controller (PLC, etc.).

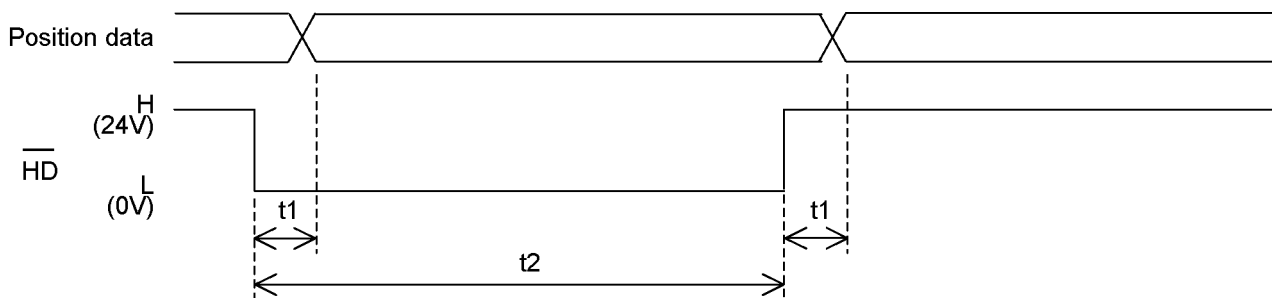

	Switch setting	t1	t2
PC synchro format		230μs	200μs or more

8-4. Current Position Setting

The current position setting function changes the converter's position data output to a value that corresponds to the machine's current position. The position data can be changed to any desired value by using the rotary switch on the control panel.

If an extension sensor cable is being used, the cable must be connected when performing the current position setting function.

(1) For binary code output

<Current position setting procedure>

- 1) Secure the sensor to the machine, then move the machine to the desired position.
- 2) Obtain the position data that corresponds to the machine's current position.
- 3) Use the control panel's rotary switches (in the D0 to D3 order) to specify monitor LED values that match the position data obtained at step 2) above.

[Ex] Setting a "0000H" current position value

□: Light ON ■: Light OFF

Procedure	Position data monitor LED	Rotary switch	Explanation
—		0 D3 0 D2 0 D1 0 D0	When the rotary switch is at "0000" ^H position, the output LED indicators read "4BD7" ^H .
1		0 D3 0 D2 0 D1 9 D0	Turn D0 rotary switch until the all D0 output LED indicators are OFF.
2		0 D3 0 D2 2 D1 9 D0	Turn D1 rotary switch until the all D1 output LED indicators are OFF.
3		0 D3 4 D2 2 D1 9 D0	Turn D2 rotary switch until the all D2 output LED indicators are OFF.
4		B D3 4 D2 2 D1 9 D0	Turn D3 rotary switch until the all D3 output LED indicators are OFF.

(2) For gray binary code output

<Current position setting procedure>

- 1) Secure the sensor to the machine, then move the machine to the desired position.
- 2) Obtain the position data that corresponds to the machine's current position.
- 3) Convert the position data obtained at step 2) above to gray binary code.
- 4) Use the control panel's rotary switches (in the D0 to D3 order) to specify monitor LED values that match the value converted at step 3) above.

*Each digit (D0 to D3) of gray binary code may not be adjusted to target values.

If it is not able to adjust, set the value by following methods:

1. Add "8H" to the setting value of each digit when setting the digit of D0 to D2. One upper digit is specified when one lower digit is also set up.
2. Add "8000H" to the current position data (it is the confirmed value in step 3)) when setting the digit of D3, then set the digit of the D0 again.

[Ex] Setting a "0000H" current position value

□: Light ON ■: Light OFF

Procedure	Position data monitor LED	Rotary switch	Explanation
—		0 D3 0 D2 0 D1 0 D0	When the rotary switch is at "0000 ^H " position, the output LED indicators read "4BD7 ^H ".
1		0 D3 0 D2 0 D1 5 D0	Turn D0 rotary switch until the output D0 LED indicators read "0 ^H ".
2		0 D3 0 D2 6 D1 5 D0	Turn D1 rotary switch until the output D1 LED indicators read "8 ^H ".
3		0 D3 D D2 6 D1 5 D0	Turn D2 rotary switch until the output D2 LED indicators read "0 ^H ". At this time, D1 LED indicators also read "0 ^H ".
4		8 D3 D D2 6 D1 5 D0	Turn D3 rotary switch until the output D3 LED indicators read "8 ^H ".
5		8 D3 D D2 6 D1 6 D0	Turn D0 rotary switch to the right one time so that D3 output LED indicators read "0 ^H ".

9. MAINTENANCE and INSPECTIONS

The inspection should be conducted once every 6 months to a year.

Any inspected items which do not satisfy the criteria shown below should be repaired.

9-1. Inspection

Inspection item	Inspection Description	Criteria	Remark
Power supply	Measure the voltage fluctuation at the power supply terminal block of the converter to determine if it is within the prescribed range.	Power supply voltage fluctuation must be within 21.6V to 26.4VDC range	Tester
Ambient Conditions	Check the ambient temperature.	ABSOCODER: -20 to +120°C Converter: 0 to +55°C	Thermometer
	There should be no accumulation of dust.	None	
Mount Conditions	Verify that the sensor is securely mounted.	There should be no looseness.	
	Verify that the sensor shaft is securely coupled to the machine shaft.	There should be no looseness.	
	Check for severed cables.	Cable should appear normal.	Visual Inspection
	Verify that the sensor cable connector is plugged in all the way.	There should be no looseness.	
	Verify that the I/O connector is plugged in all the way.	There should be no looseness.	

9-2. Troubleshooting

The causes and corrective actions for errors that may occur during NCV-20H operation are described below.

Error item	Cause	Countermeasure
Sensor disconnected LED (SE) is ON.	Sensor connector is disconnected.	Secure the connector
	Sensor connector is loose.	
	Sensor cable is severed.	Replace the sensor cable
Deviation in origin point position.	Coupling of sensor shaft and machine shaft is loose.	Secure the coupling or mounting.
	Sensor mounting is loose.	
Incorrect position data output	Latch pulse output signal and position data reading timing is improper.	Correct the reading timing.
	HOLD input signal and position data reading timing is improper.	
	The wiring of the output signal has problems.	Repair the wiring.
Position data HOLD doesn't occur.	The function setting switch is incorrect.	Change the setting.
	The voltage of the power supply for input and output is out of prescribed range.	Supply the correct power voltage. 21.6V to 26.4VDC
	The wiring of the input signal has problems.	Repair the wiring.
No position data output	The function setting switch is incorrect.	Change the setting.
	The voltage of the power supply for input and output is out of prescribed range.	Supply the correct power voltage. 21.6V to 26.4VDC
	"HD"(the external input signal) is ON.	Check the signal.
	The wiring of the output signal has problems.	Repair the wiring.

If the troubleshooting procedures described above fail to solve the problem, the sensor or converter may be defective. In this case, please contact your NSD representative.

10. ABSOCODER SENSOR CHECK LIST

● **Applicable ABSOCODER sensor models**

VRE-16TS100

● **Connection configuration**

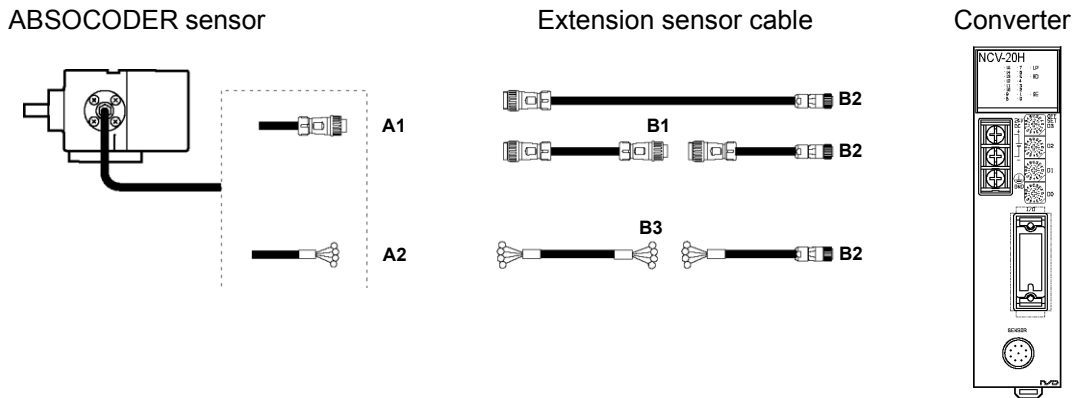

● **Connector appearance and pin position**



● **Connector pin position and standard coil resistance ranges (at 25°C)**

Check position				Signal names	Standard coil resistance [Ω]
A1, A2, B1, B2		B3			
Pin No.	Wiring color	Pin No.	Wiring color		VRE-16TS100
1	Brown	1	Brown	U	115 to 135
2	Red	2	Red	V	
3	Orange	3	Orange	W	
4	—	4	—	—	18 to 28
5	Green	5	Green	OUT1+	
6	Blue	6	Blue	OUT1-	25 to 35
7	Violet	7	Violet	OUT2+	
8	Gray	8	Gray	OUT2-	
9	—	—	—	—	
10	—	—	—	—	
11	Shield	9	Shield	Shield	
12	—	—	—	—	

The above standard coil resistance ranges are referential data to assist wiring disconnection diagnosis and are not product specification values. There may be no wiring disconnection even when the resistance measurement is out of the standard resistance range.

● **Circuit resistance check**

[Measurement method]

Measure resistance at Point A or B using a circuit tester or other appropriate device.

Have Point A connected to measure at Point at B.

If the connector is off, identify the line by the wiring color.

[Check details]

Refer to the previous page for the connector pin number.

Check position	Criterion	Check position	Criterion
Between brown and red	The measured value should be in the range of the standard coil resistance. *1	Between brown and, green, violet, shield	∞
Between brown and orange		Between green and, violet, shield	
Between red and orange		Between violet and shield	
Between green and blue		Between frame and each wire or shield	
Between violet and gray			

*1: If checks are done at Point B, the measurement value is [Standard coil resistance + extension sensor cable resistance.]

Extension sensor cable resistance value

The resistance value of the NSD special cable is 0.2Ω/m (loop resistance).

Consider resistance variations due to temperature, which, relative to the standard temperature (25°C), increases 0.4% when the temperature rises 1°C and decreases 0.4% when the temperature falls 1°C.

● **Insulation check**

[Measurement method]

Measure using a 500 VDC insulation tester.

[Check details]

Refer to the previous page for the connector pin number.

Check position	Criterion
Between brown and, green, violet, shield	10MΩ or more
Between green and, violet, shield	
Between violet and shield	
Between frame and each wire or shield	

 **NOTES**

1. Make sure to disconnect the ABSOCODER sensor from the converter before carrying out insulation checks.
2. If there is a risk that energization may cause damages to the electronic circuits in and around the machine, remove the ABSOCODER sensor from the machine.
3. After completing the checks, short-circuit between the pins to discharge remaining voltage before connecting the ABSOCODER sensor to the converter.



NSD Group

Manufacturer

NSD Corporation 3-31-28, OSU, NAKA-KU, NAGOYA, JAPAN 460-8302

Distributor

NSD Trading Corporation 3-31-23, OSU, NAKA-KU, NAGOYA, JAPAN 460-8302

Phone: +81-52-261-2352 Facsimile: +81-52-252-0522

URL: www.nsdcorp.com E-mail: foreign@nsdcorp.com

Copyright©2020 NSD Corporation All rights reserved.