



ZEF004570507



ABSOCODER CONVERTER

NCV-30NBNLC
NCV-30NGNLC

Specifications & Instruction Manual

Applicable sensor: CYLNUC cylinder
VLS-12.8
IRS-51.2



GENERAL SAFETY RULES



(Please read this safety guide carefully before operation)

Thank you very much for purchasing our product. Before operating this product, be sure to carefully read this manual so that you may fully understand the product, safety instructions and precautions.

- Please submit this manual to the operators actually involved in operation.
- Please keep this manual in a handy place.



Signal Words

Safety precautions in this guide are classified into DANGER and CAUTION.

Symbol	Meaning
 DANGER	Incorrect handling may cause a hazardous situation that will result in death or serious injury.
 CAUTION	Incorrect handling may cause a hazardous situation that will result in moderate injury or physical damage.

Instructions accompanied by a symbol  may also result in serious damage or injury. Be sure to follow the all instructions accompanied by the symbol.

Graphic Symbols







Symbol	Meaning
	Indicates prohibited items.
	Indicates items that must be performed to.



Application Limitation

This product is not designed to be used under any situation affecting human life. When you are considering to use this product for special purposes such as medical equipment, aerospace equipment, nuclear power control systems, traffic systems, and etc., please consult with NSD.



This product is designed to be used under the industrial environments categorized in Class A device. The supplier and user may be required to take appropriate measures.

1. Handling Precautions



 DANGER	
	- Do not touch components inside of the controller; otherwise, it will cause electric shock.
	- Do not damage the cable by applying excessive load, placing heavy objects on it, or clamping; otherwise, it will cause electric shock or fire.
	- Turn the power supply OFF before wiring, transporting, and inspecting the controller; otherwise, it may cause electric shock.
	- Provide an external safety circuit so that the entire system functions safely even when the controller is faulty.
	- Connect the grounding terminal of the controller; otherwise, it may cause electric shock or malfunction.

 CAUTION	
	- Do not use the controller in the following places; water splashes, the atmosphere of the corrosion, the atmosphere of the flammable vapor, and the side of the combustibility. Doing so may result in fire or the controller may become faulty.
	- Be sure to use the controller and the ABSOCODER sensor in the environment designated by the general specifications in the manual. Failure to do so may result in electric shock, fire, malfunction or unit failure. - Be sure to use the specified combination of the ABSOCODER sensor, controller and sensor cable; otherwise, it may cause fire or controller malfunction.



2. Storage

 CAUTION	
	- Do not store the controller in a place exposed to water, or toxic gas and liquid.
	- Be sure to store the controller in designed temperature and humidity range, and do not exposed to direct sunlight. - Be sure to consult with NSD when the controller is stored for long periods.



3. Transport



 CAUTION	
	- Do not hold the cable or shaft of ABSOCODER sensor during transport; otherwise, it will cause injury or controller malfunction.

4. Installation



 CAUTION	
	- Do not step on the ABSOCODER sensor or place heavy objects on the controller; otherwise, it will cause injury. - Do not block the exhaust port or allow any foreign matter to enter the controller; otherwise, it will cause fire or unit failure.
	- Be sure to secure the controller and ABSOCODER sensor with the provided brackets; otherwise, it may cause malfunction, injury, or drop. - Be sure to secure the specified distance between the main body and the control panel or other equipments; otherwise, it may cause malfunction.

5. Wiring



 DANGER	
	- Be sure to secure the terminal block firmly; otherwise, it may have risk of fire. - Be sure to mount the terminal cover provided with the controller, before supplying the power, starting operation after the installation, and wiring; otherwise, it may cause electric shock.

 CAUTION	
	- Be sure to keep the sensor cable, control cable, and communication cable at least 300 mm away from the main circuit and power line; otherwise it may cause injury or malfunction. - Be sure to connect all cables correctly; otherwise, it may cause injury or controller malfunction. - Be sure to firmly connect the external I/O connectors and sensor connectors; otherwise, it may cause incorrect inputs and outputs or injury.



6. Operation

 CAUTION	
	- Do not change the controller's function switch settings during the operation; otherwise, it will cause injury. - Do not approach the machine after instantaneous power failure has been recovered. Doing so may result in injury if the machine starts abruptly, it will cause injury.
	- Be sure to check that the power supply specifications are correct; otherwise, it may caused controller failure. - Be sure to provide an external emergency stop circuit so that operation can be stopped with power supply terminated immediately. - Be sure to conduct independent trial runs for the controller before mounting the controller to the machine; otherwise, it may cause injury. - When an error occur, be sure to eliminate the cause, ensure safety, and reset the error before restarting operation; otherwise, it may cause injury.

7. Maintenance And Inspection

 CAUTION	
	- Do not disassemble, remodel, or repair the unit; otherwise, it will cause electric shock, fire, and unit malfunction.
	- The capacitor of the power line deteriorates through prolonged use. We recommended that the capacitor be replaced every five years to prevent secondary damage.

8. Disposal

 CAUTION	
	- Be sure to handle the controller as industrial waste while disposing of it.

REVISION HISTORY

The Document No. appears at the upper right of this manual's cover page.

Document No.	Date	Revision Description
ZEF004570500	16, Jun., 2009	1st Edition Japanese document: G-HB08002601
ZEF004570501	31, Jan., 2011	2nd Edition Japanese document: G-HB08002601
ZEF004570502	16, Sep., 2011	3rd Edition Japanese document: G-HB08002602
ZEF004570503	7, Feb., 2012	4th Edition Japanese document: G-HB08002602
ZEF004570504	9, Apr., 2013	5th Edition Japanese document: G-HB08002603
ZEF004570505	6, Dec., 2013	6th Edition Japanese document: G-HB08002604
ZEF004570506	23, Jan., 2015	7th Edition Japanese document: G-HB08002605
ZEF004570507	7, Mar., 2016	8th Edition Japanese document: G-HB08002606

- MEMO -

CONTENTS

1. OVERVIEW	1
1-1. Features.....	1
1-2. Limitations.....	2
1-3. Additional Function.....	2
2. CONFIGURATION	3
2-1. Model List.....	3
3. SPECIFICATIONS	4
3-1. Converter Specifications.....	4
3-2. ABSOCODER Sensor Specifications.....	7
3-3. Extension Sensor Cable Specification.....	7
4. DIMENSIONS	8
4-1. Converter.....	8
4-2. ABSOCODER Sensor.....	8
4-3. Extension Sensor Cable.....	9
5. INSTALLATION	10
5-1. Converter Installation Conditions and Precautions.....	10
5-2. ABSOCODER Sensor Installation Conditions and Precautions.....	11
5-3. CE Marking.....	12
5-3-1. EMC Directives.....	12
5-3-2. EMC Directive and Standards.....	12
5-3-3. Measures for EMC Compliance.....	12
5-3-4. Restrictions.....	13
6. WIRING	14
6-1. Connection between Converter and ABSOCODER Sensor.....	14
6-2. Power Supply Connection.....	15
6-3. Input / Output Connector Connection.....	16
6-3-1. Pin arrangement of the I/O Connector.....	16
6-3-2. I/O Circuit.....	17
7. NOMENCLATURE	18
7-1. Part Identification.....	18
7-2. Function and Name of Display and Setting Area.....	18

8. OPERATION	19
8-1. Operation Sequence	19
8-2. Settings of the Function Setting Switch	20
8-3. Position Data "Increase Direction" Setting	22
8-4. Position Data Reading Setting	23
8-4-1. Position Data Reading by LP output	23
8-4-2. Position Data Reading by HOLD (HD) Input	25
8-5. Position Data Output Format Setting	27
8-6. System Ready Signal	28
8-7. Zero Point Setting	29
8-7-1. Zero Point Setting Procedure	29
8-7-2. Timing of the Zero Point Setting when Using a Latch Pulse Signal	30
8-7-3. Timing of the Zero Point Setting when Using a HOLD Signal	31
8-8. Error Clear	32
 9. INSPECTIONS	 34
 10. TROUBLESHOOTING	 35
10-1. Display and Countermeasure when an Error Occurred	35
10-2. Output State when Occurring an Error	37
10-3. Procedure Contents after Replacing	37
10-4. ABSOCODER Check Lists	39

1. OVERVIEW

The NCV-30 Series can be combined with a linear type of ABSOCODER (CYLNUC Cylinder, "VLS-12.8 or IRS-51.2") to convert the detected position data to binary or gray codes for output.

1-1. Features

(1) Superior durability

NSD's original ABSOCODER is used as the position sensor which features a no-contact construction for excellent durability.

(2) Compact design

The unit's outside dimensions (39(W) x 155(H) x 93(D)) were miniaturized, and the shape of case is a bookshelf type. DIN rail mounting is also possible.

(3) Zero point setting function

The position data can be set to "0" by using either pressing the "ZPS" switch on the front panel or inputting the " $\overline{\text{ZPS}}$ " external input signal.

(4) A full array of position data reading formats

a) Latch pulse format

Position data reading occurs by synchronizing with the latch pulse signal output from the converter. A position data update cycle (0.2ms, 0.4ms, 0.8ms, 1.6ms, 3.2ms, 12.8ms, 25.6ms, 51.2ms) which is suitable for the host controller's reading speed can be selected.

b) HOLD signal format

A HOLD signal is input to the converter to stop position data output updates, with the position data then being read.

This desired HOLD signal format can be selected from two types:

- The transparent format in which data reading occurs while the HOLD signal is ON.
- The PC synchro format in which position data updates occurs at the HOLD signal's leading or trailing edge.

(5) Selection of the position data output format

The desired position data output format can be selected from three formats; binary code, sign magnitude code, minus zone "0" output.

Applicable model: NCV-30NBNL

(6) Error detection function

The error content can be checked by a converter monitor "LED" when an error occurs.

A status output is also provided, enabling reading to a host controller (PLC, etc.).

(7) Compliance with UL and CE standards

The NCV-30 Series complies with both UL (UL508) and CE (EMC Directive) standards, and therefore presents no problems when used in equipment which is to be exported abroad.

(8) Compliance with KC mark (Korea Certification Mark)

The NCV-30 Series complies with KC mark. (It is only certified under the Radio Waves Act of South Korea.) KC mark is the same directives as CE marking. For more details, refer to "5-3. CE Marking".

1-2. Limitations



Important

Cautions concerning power-off and error occurrence

If the sensor moves while the converter power is OFF or when an error is present, it mightn't detect accurate machine positions thereafter.

The zero position setting should be done after turning ON the power supply or clearing the error.

For setting details, refer to "8-7. Zero Point setting".

1-3. Additional Function

The NCV-30 Series is upgraded by adding the following functions.

The upgrade model has a mark "SP1" in the bottom left corner of the front panel. Please check the mark.

Additional function	"SP1"		Reference
	None	Added	
Sign magnitude code format	×	○	8-5. Position Data Output Format Setting
Minus zone "0" output format	×	○	

2. CONFIGURATION

Indicates the configuration of NCV-30. Contact your NSD representative for details of ABSOCODER sensor and the extension sensor cable.

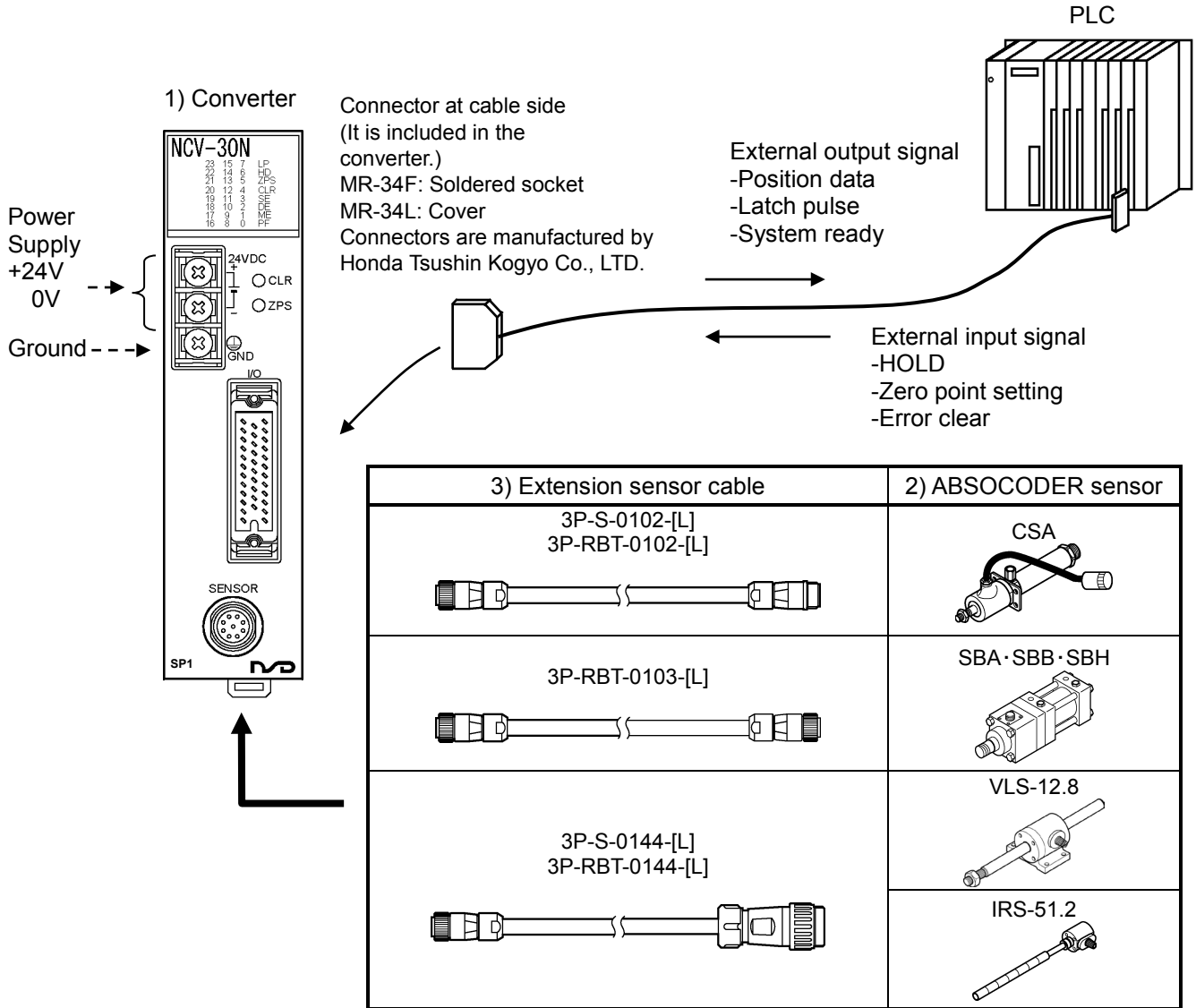

2-1. Model List

No.	Items	Models	Descriptions
1)	Converter	NCV-30NBNL	Position data 24bit binary code output
		NCV-30NGNL	Position data 24bit gray code output
2)	ABSOCODER sensor	CSA, SBA, SBB, SBH	CYLNUC Cylinder, resolution: 1.5625 μ m
		VLS-12.8	Rod sensor, resolution: 1.5625 μ m
		IRS-51.2	Inrodsensor, resolution: 6.25 μ m
3)	Extension sensor cable	3P-S-0102-[L]	Standard cable, [L]: cable length
		3P-RBT-0102-[L]	Robotic cable, [L]: cable length
		3P-RBT-0103-[L]	Robotic cable, [L]: cable length
		3P-S-0144-[L]	Standard cable, [L]: cable length
		3P-RBT-0144-[L]	Robotic cable, [L]: cable length

3. SPECIFICATIONS

3-1. Converter Specifications

(1) General Specification

Items	Specifications
Power supply voltage	24VDC±10% (including ripple)
Power consumption	10W or less
Insulation resistance	20 M-Ohms or more between external DC power terminals and ground (by 500 VDC insulation resistance tester)
Withstand voltage	500 VAC, 60Hz for 1 minute between external DC power terminals and ground
Vibration resistance	20m/s ² 10 to 500Hz, 10cycles of 5 minutes in 3 directions, conforms to JIS C 0040 standard
Ambient operating temperature	0 to +55°C (No freezing) (Surrounding air temperature rating of 55°C maximum)
Ambient operating humidity	20 to 90 %RH (No condensation)
Ambient operating environment	Free from corrosive gases and excessive dust
Ambient storage temperature	-10 to +70°C
Grounding	Must be securely grounded (ground resistance of 100 ohm or less)
Construction	Book-shelf type within enclosure, DIN rail mountable
Outside dimension (mm)	39(W) x 155(H) x 93(D) Refer to dimensions for details.
Mass	Approx. 0.4kg

(2) Performance Specification

Items	Specifications			
Converter model	NCV-30NBNLC		NCV-30NGNLC	
Applicable sensor	CSA·SBA·SBB·SBH VLS-12.8	IRS-51.2	CSA·SBA·SBB·SBH VLS-12.8	IRS-51.2
Resolution	1.5625 μ m	6.25 μ m	1.5625 μ m	6.25 μ m
Position detection format	Semi-absolute format			
Total number of divisions	Standard pitch x number of pitches (8192 divisions (2 ¹³) x max. 2048 pitches)			
Output code	Binary code output: 24-bit Sign magnitude code: 23-bit (SIGN output: 1-bit) Minus zone "0" output: 24-bit		Gray code output: 24-bit	
Number of detection axes	1			
Position data sampling time	0.2ms			
Status output signal	Latch pulse (position data reading timing signal): 1 point System ready: 1 point			
Input signal	Position data HOLD signal: 1 point Zero point setting signal: 1 point Error clear signal: 1 point			
Front panel function	Zero point setting, error clear			
Switch (on rear face of product)	Position data increase direction setting (CW / CCW): 1 point			
	Position data update cycle	High-speed	0.2ms	
			0.4ms	
			0.8ms	
		Low-speed	1.6ms	
			3.2ms	
			12.8ms	
	HOLD signal format	Transparent format		
		PC synchro format		
	Position data output format	Binary code output		
Sign magnitude code				
Minus zone "0" output				
Monitor LED	Output state monitor	Position data output, latch pulse output		
	Input state monitor	HOLD input, zero point setting input, error clear input		
	Error state monitor	Sensor disconnected error, sensor data error, memory error, low power error, -5V power supply error, LPA error		
Applicable standard	UL508 CSA C22.2 No.142 (Compliance with UL standard) CE marking (EMC directive) KC mark (Korea Certification Mark)			

(3) Input / Output Specification

Items		Specifications
Input	Input signals	\overline{HD} (Position data HOLD): 1 point \overline{ZPS} (Zero point setting): 1 point \overline{CLR} (Error clear): 1 point
	Input circuit	DC input, photo-coupler isolation
	Input logic	Negative logic
	Rated input voltage	12 to 24VDC (10.8 to 26.4VDC)
	Rated input current	10mA(24VDC)
	ON voltage	10VDC or more
	OFF voltage	4VDC or less
	Response Time	ON OFF
Output	Output signals	$\overline{D0}$ to $\overline{D23}$ (Position data): 24 points \overline{LP} (Latch pulse: position data reading timing): 1 point \overline{NOR} (System ready): 1 point
	Output circuit	Photo-coupler isolation, open drain (sink output)
	Output logic	Negative logic
	Rated load voltage	12 to 24VDC (30VDC max.)
	Max. load current	50mA / point
	Max. voltage drop when ON	0.8V

*Refer to "6-3. Input / Output Connector Connection" about I/O circuit.

3-2. ABSOCODER Sensor Specifications

Models		CYLNUC cylinder	Rod sensor	Inrodsensor
		CSA · SBA · SBB · SBH	VLS-12.8	IRS-51.2
Absolute detection range		12.8mm (0.5039inch)		51.2mm (2.0157inch)
Resolution		1.5625 μ m (12.8mm/8192)		6.25 μ m (51.2mm/8192)
Max. sensor cable length	Standard cable	100m (3P-S)		
	Robotic cable	50m (3P-RBT)		

*For more details, contact your NSD representative.

3-3. Extension Sensor Cable Specification

Items		Specifications	
Model code		3P-S	3P-RBT
Cable type		Standard cable	Robotic cable
Diameter		ϕ 8	
Ambient temperature	Operating	-5 to +60°C	
	Storage	-5 to +60°C	-10 to +60°C
Insulator		Irradiated cross linked foamed polyethylene	ETFE plastic
Sheath		Vinyl chloride mixture	
Color		Gray	Black
Advantage		Extensible for long distances	Superior flexibility; ideal for moving place

[Remark]

Contact your NSD representative when the extension cable combines different types of cables.

4. DIMENSIONS

4-1. Converter

Units: mm

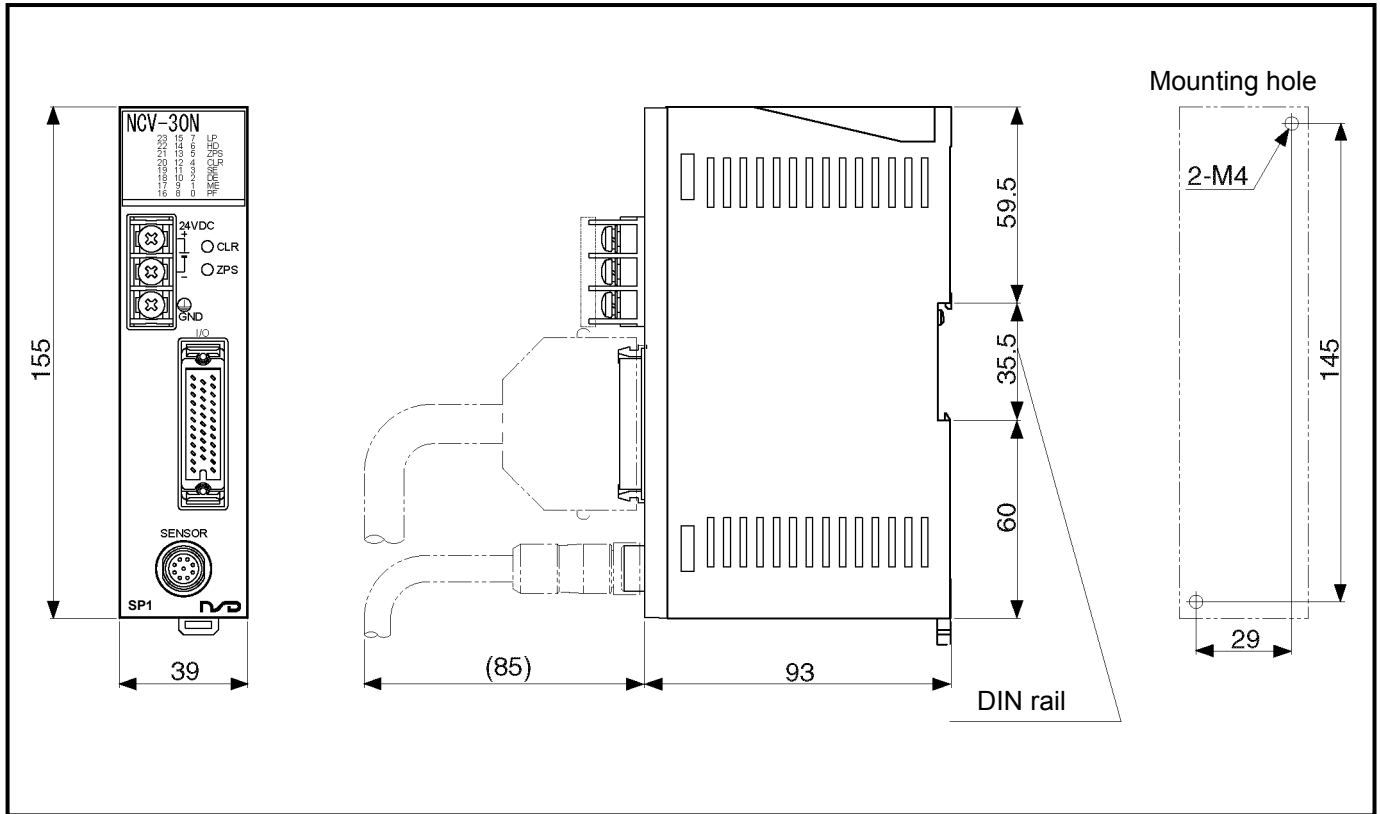

4-2. ABSOCODER Sensor

Contact your NSD representative for ABSOCODER sensor dimension.

4-3. Extension Sensor Cable

(1) 3P-S-0102-[L]/3P-RBT-0102-[L]

Units: mm

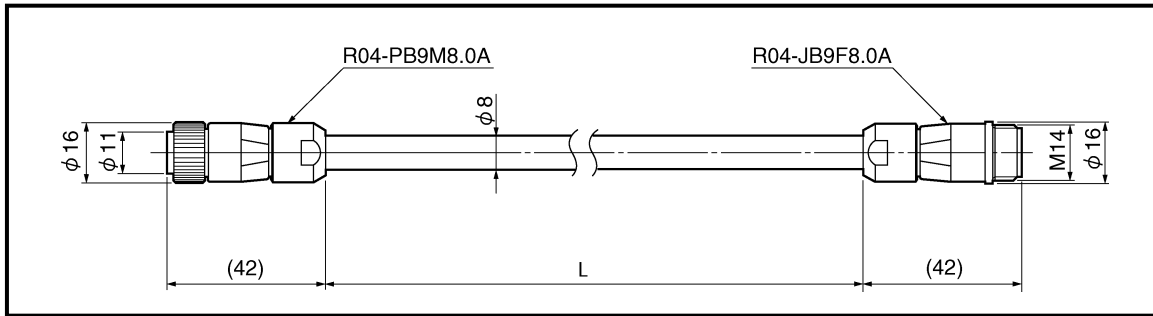

(2) 3P-RBT-0103-[L]

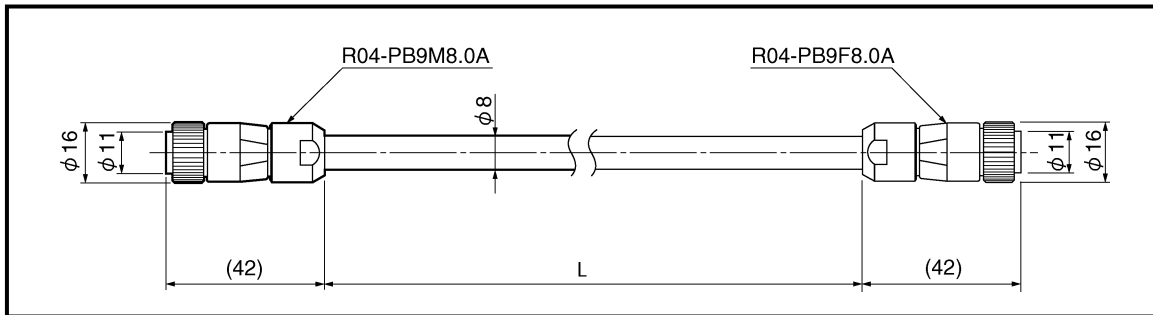

(3) 3P-S-0144-[L]/ 3P-RBT-0144-[L]

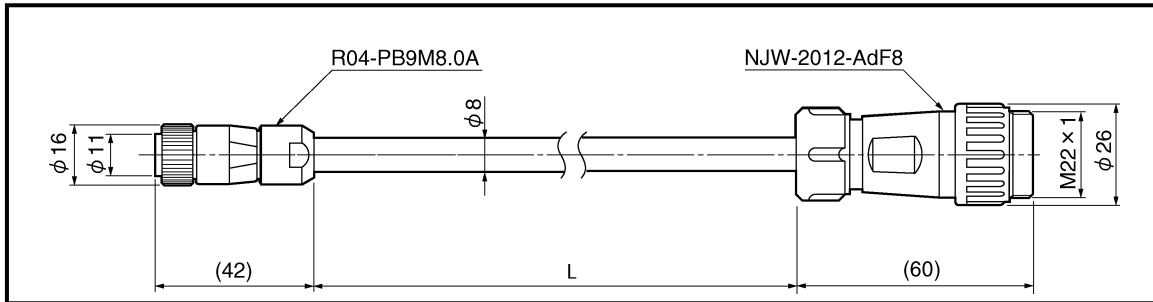

5. INSTALLATION

5-1. Converter Installation Conditions and Precautions

When installing the converter, the following conditions and precautions should be observed.

-Installation Site

- (1) Avoid sites where the unit is exposed to direct sunlight.
- (2) The ambient temperature should never exceed a 0 to 55°C range.
- (3) The ambient humidity should never exceed a 20 to 90% RH range.
- (4) Do not install the unit in areas where condensation is likely to occur (high humidity with extreme temperature changes).
- (5) Avoid sites where dust is excessive.
- (6) Do not install in areas with an excessive amount of salt and/or metal chips.
- (7) Do not install in areas where flammable and / or corrosive gases are present.
- (8) Avoid areas where splashing water, oil or chemicals are likely to occur.
- (9) Avoid areas where vibration and shocks are excessive.

-Installation cautions

- (1) Install inside the control cabinet.
- (2) Install in a vertical direction so that the characters are visible.
- (3) If a DIN rail mounting format is used, insert until the latch mechanism catches with an audible click.
Secure between end plates at both sides.
- (4) In high vibration areas, secure tightly with 2 M4 screws.
- (5) Install as far from high voltage lines and power lines as possible in order to minimize noise influences.
- (6) Allow 85mm or more space at the converter's front side for plugging in and unplugging the connector.
- (7) Peripheral components should be arranged so as not to obstruct converter installation, removal, and connector plugging/unplugging.
- (8) Space out 10mm or more between the converter and peripheral components in order not to obstruct the converter's heat dissipation.

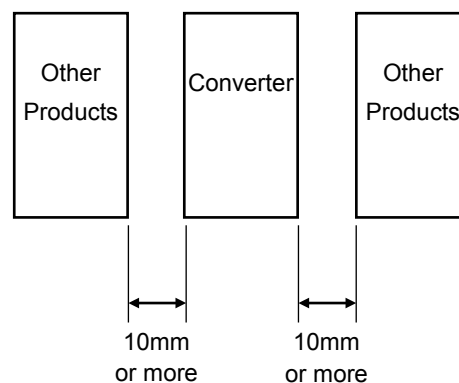
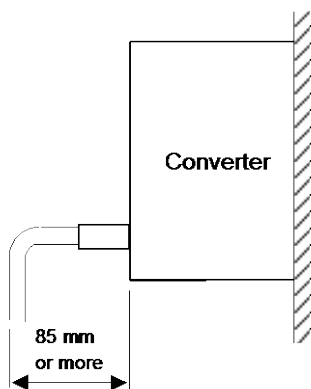

5-2. ABSOCODER Sensor Installation Conditions and Precautions

The installation conditions and precautions for ABSOCODER sensor are described in this section.

- 1) Do not apply excessive forces to the cable terminal area, and avoid damaging the cable.

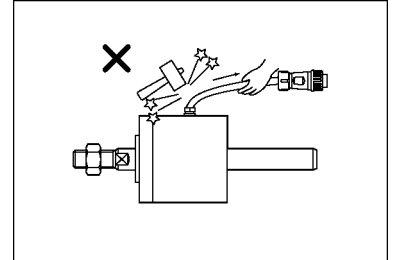

- 2) The part of a machine mounted the sensor rod must travel in the same direction as the sensor rod extends and contracts.

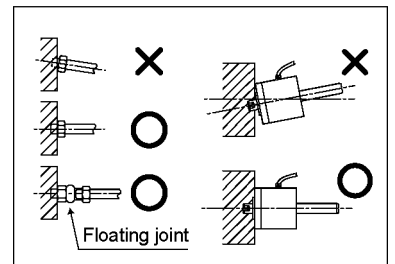

- 3) When the cable port is exposed, a shielding plate should be installed as shown in the right figure.

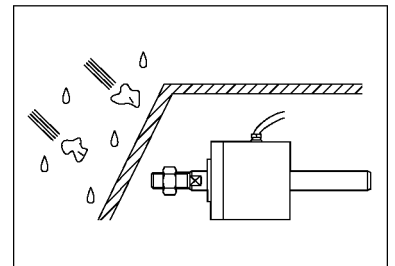

Contact your NSD representative for details of the installation conditions and precautions for ABSOCODER sensor.

5-3. CE Marking

NCV-30 Series conforms to CE Marking (EMC directive), but stands outside scope of the low voltage directive because it is 24 VDC power apparatus.

5-3-1. EMC Directives

It is necessary to do CE marking in the customer's responsibility in the state of a final product. Confirm EMC compliance of the machine and the entire device by customer because EMC changes configuration of the control panel, wiring, and layout.

5-3-2. EMC Directive and Standards

EMC Directive consists of immunity and emission items. It conforms to Table 01(see below) of EMC standards and Testing.

Table 01 EMC Standard and Testing

Class	Standard No.	Name
EMI (Emission)	EN61000-6-4	Generic standards. Emission standard for industrial environments
	EN55011 Class A	Electromagnetic radiation disturbance
EMS (Immunity)	EN61000-6-2	Generic standards. Immunity standard for industrial environments
	EN61000-4-2	Electrostatic discharge
	EN61000-4-3	Radiated, radio frequency, electromagnetic field
	EN61000-4-4	Electrical fast transient / burst
	EN61000-4-5	Surge immunity
	EN61000-4-6	Conducted disturbances, induced by radio-frequency fields
	EN61000-4-8	Power frequency magnetic field

5-3-3. Measures for EMC Compliance

Describes measures for EMC compliance when testing the compatibility verification.

- Mounts the Clamp ferrite core on the sensor cable.
- Mounts the Clamp ferrite core within 200mm from the unit body.
- It is effect to reduce the conduction and radiation noise.

Clamp ferrite core
 Model: ZCAT2032-0930
 Inner dimensions: $\phi 9$
 Manufacturer: TDK
 (Accessory)

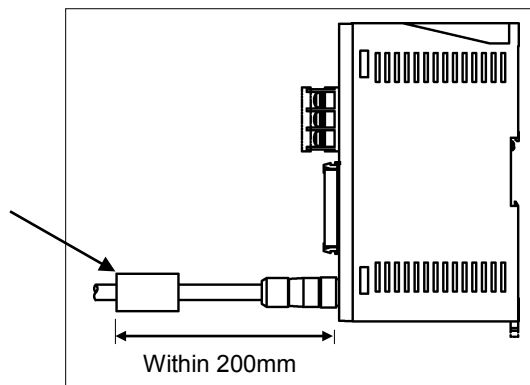

5-3-4. Restrictions

The I / O cable must be under 30m from the host controller to the converter. The wiring should be surely secured.

[Reference]

It may be improved when clamp ferrite core is added to the power supply cable, sensor cable, and I/O cable when it operates faultily by the influence from the peripheral device.

Recommendation Clamp Ferrite Core (Product name: Clamp filters for cable)

Mounting location	Clamp ferrite core model	Manufacturer
Power supply cable, sensor cable	ZCAT2032-0930 (Inner dimensions: ϕ 9)	TDK
I / O cable	ZCAT3035-1330 (Inner dimensions: ϕ 13)	TDK

6. WIRING

6-1. Connection between Converter and ABSOCODER Sensor

The maximum extension sensor cable length varies according to the ABSOCODER sensor and cable model being used. Please refer to the 3-2 for details.

● Wiring Precautions

- (1) The sensor cable should be clamped as shown in the right figure to prevent excessive tension from being applied to the cable connectors.
- (2) The sensor cable should be located at least 300mm away from power lines and other lines which generate a high level of electrical noise.
- (3) If the cable is moved under the state of bending like a horseshoe, a robotic cable should be used. The bend radius should never be less than 75 mm.

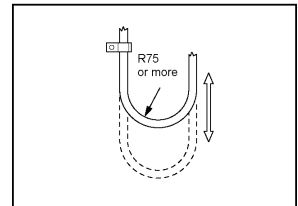
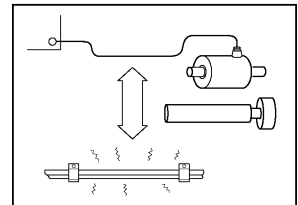
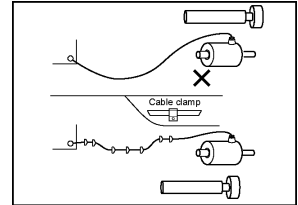

● Connection example of the sensor cable

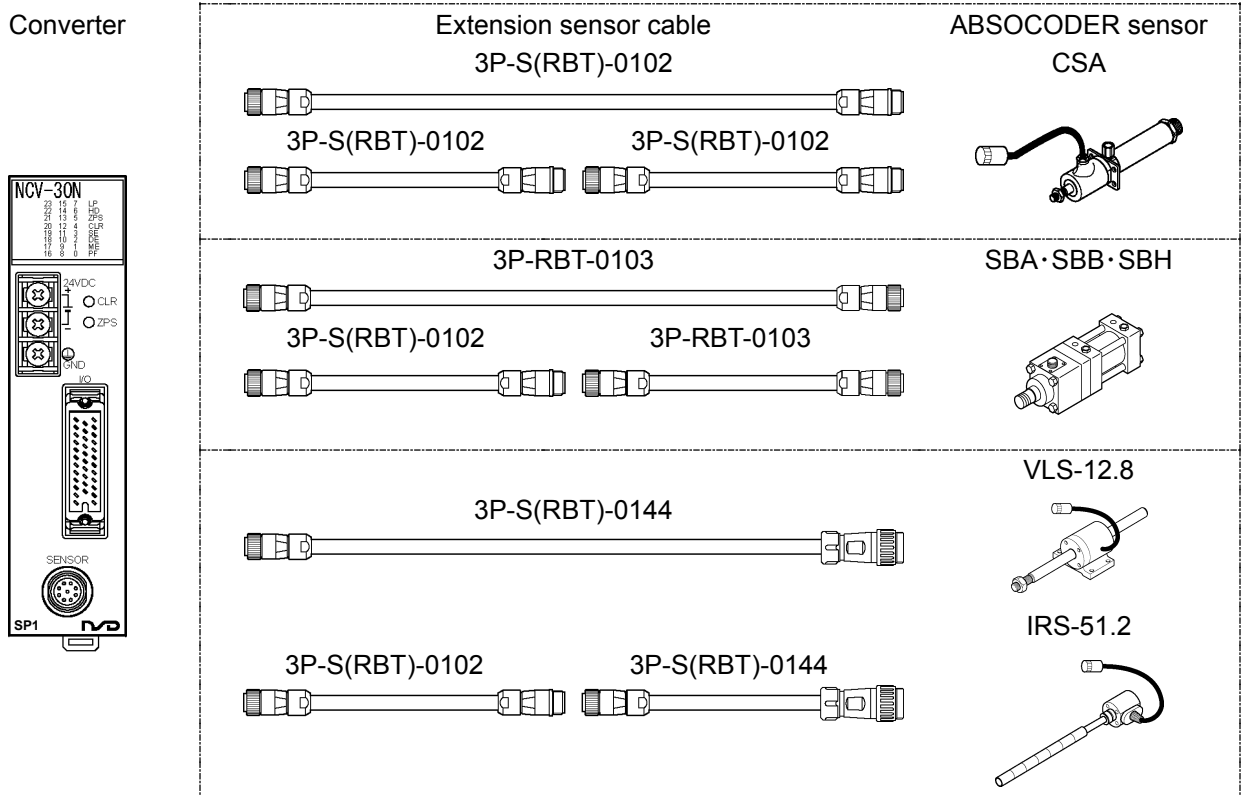

6-2. Power Supply Connection

The power supply should be connected as described below:

(1) Power Supply

- The rush current is 10A(rush time of 20ms), so select the power supply after due consideration. Choose the capacity of the power supply over double of power consumption of converter.
- The input power supply should be isolated from the commercial power supply.
- Twist the power cable for preventing noises.
- Use the M4 size crimp lug terminals with insulating sleeves in order to prevent short circuit caused by loose screws.

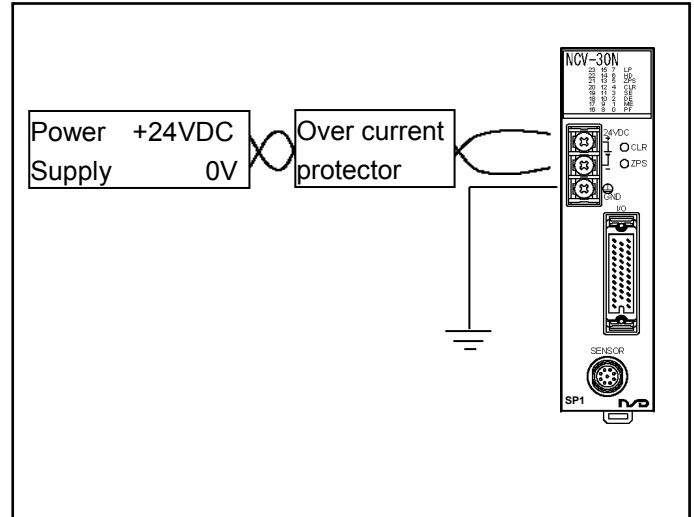

- Use a Class 2 power supply.
- Use AWG 12 to 22 electrical wires.
- Use field installed conductors with a temperature rating of 75°C or higher.
- Use electrical wires of copper or copper strand.
- The terminal block tightening torque is 1.8 N·m (16 lb·in).

(2) Ground

- The unit should be securely grounded (ground resistance of 100ohm or less) to prevent electrical shocks.
- The ground wire should be connected to the ground terminal directly.

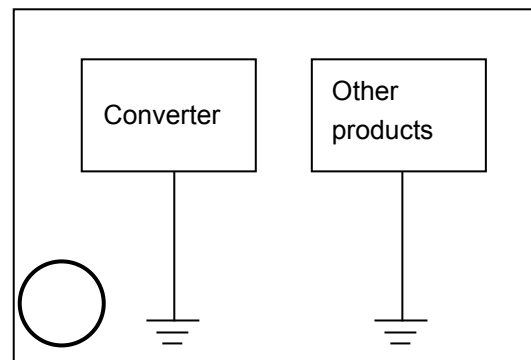
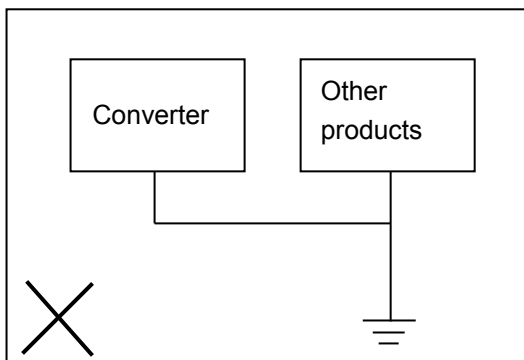

- Use AWG 12 to 14 electrical wires.
- Use field installed conductors with a temperature rating of 75°C or higher.
- Use electrical wires of copper or copper strand.
- The terminal block tightening torque is 1.8 N·m (16 lb·in).

6-3. Input / Output Connector Connection

6-3-1. Pin arrangement of the I/O Connector

Pin No.	Signal Names		Input / Output	Descriptions
1	$\overline{D0}$	Position data	Output	NCV-30NBNLC Output the position data by 24-bit of binary code. *: 24-pin outputs \overline{SIGN} signal when selecting the sign magnitude code for the position data output format. NCV-30NGNLC Output the position data by 24-bit of gray code. $\overline{D0}$: LSB (Least Significant Bit) $\overline{D23}$: MSB (Most Significant Bit)
2	$\overline{D1}$			
3	$\overline{D2}$			
4	$\overline{D3}$			
5	$\overline{D4}$			
6	$\overline{D5}$			
7	$\overline{D6}$			
8	$\overline{D7}$			
9	$\overline{D8}$			
10	$\overline{D9}$			
11	$\overline{D10}$			
12	$\overline{D11}$			
13	$\overline{D12}$			
14	$\overline{D13}$			
15	$\overline{D14}$			
16	$\overline{D15}$			
17	$\overline{D16}$			
18	$\overline{D17}$			
19	$\overline{D18}$			
20	$\overline{D19}$			
21	$\overline{D20}$			
22	$\overline{D21}$			
23	$\overline{D22}$			
24	$\overline{D23}$ or \overline{SIGN}			
25	NC			Do not connect anything.
26	\overline{NOR}	System ready	Output	The signal is "HIGH level" when the converter detects an error.
27	\overline{LP}	Latch pulse	Output	Outputs the position data reading timing signal. PLCs or other equipment can be synchronized with this signal to enable real-time reading of position data. Timing setting is set by the function setting switch.
28	\overline{HD}	HOLD	Input	The HOLD input signal is used to HOLD position data outputs from the host controller. The method in which position data is "HOLD" can be selected by the function setting switch.
29	\overline{ZPS}	Zero point setting	Input	When this signal is switched ON (under error-free conditions), the position data is set to "0" (zero set).
30	\overline{CLR}	Error clear signal	Input	This signal is switched ON to recover from an error status.
31	P24	12 to 24VDC	Input	Power supply for \overline{HD} , \overline{ZPS} , and \overline{CLR} input signals
32				
33	Z24	0VDC	Input	Ground for $\overline{D0}$ to $\overline{D23}$, \overline{LP} , and \overline{NOR} output signals
34				

Connector at cable side (It is included in the converter.)

Soldered socket: MR-34F

Cover:

MR-34L

Connectors are manufactured by Honda Tsushin Kogyo Co., LTD.

● Pin arrangement

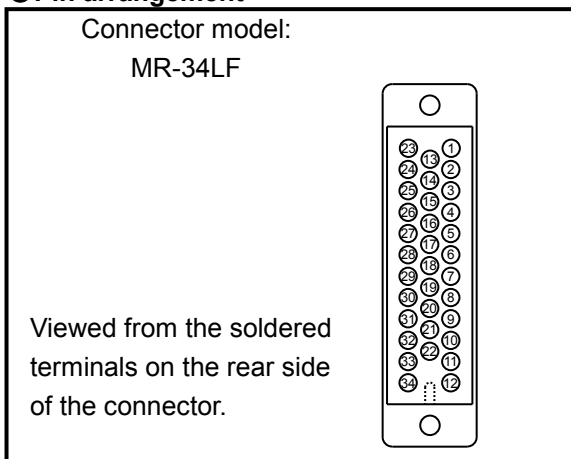

6-3-2. I/O Circuit

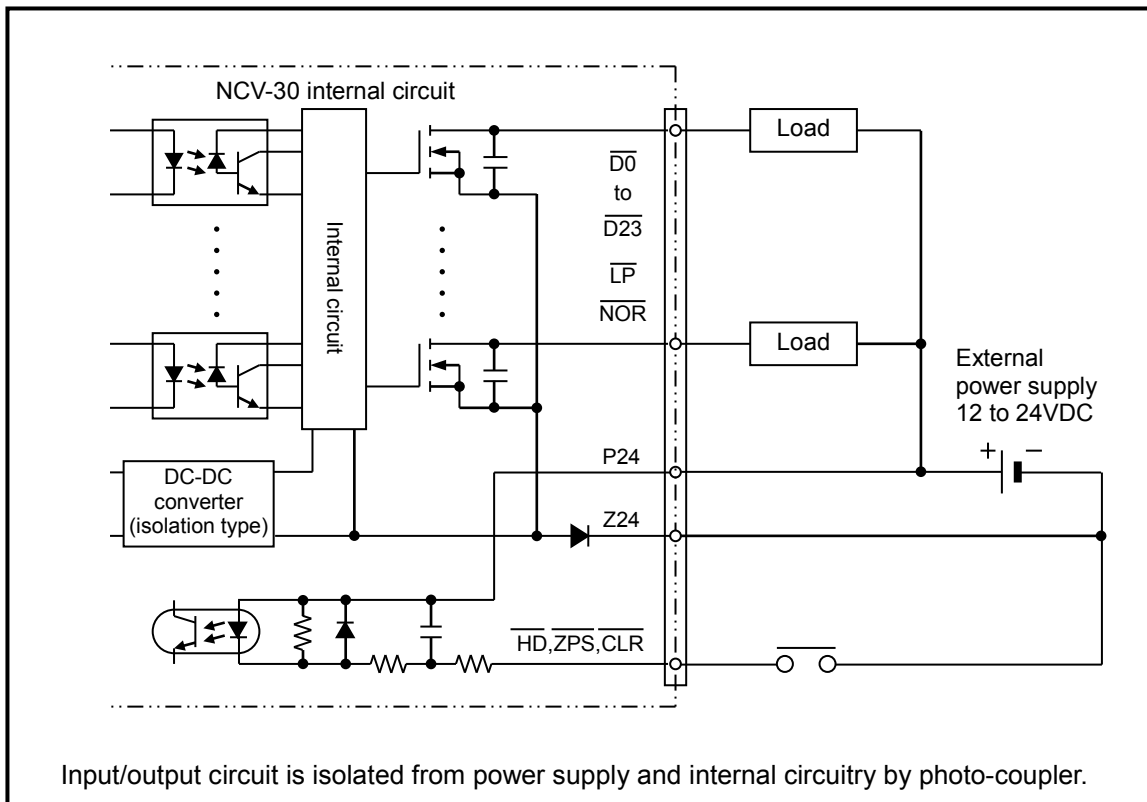

*: Use a Class 2 power supply for the input / output external power supply.

● Logic explanation

Signal name	Logic	Term in the timing chart	Output voltage
$\overline{D0}$ to $\overline{D23}$	"1" / "0" (ON / OFF)	Data bus	"1" = 0V
\overline{LP}	"LOW" / "HIGH" (ON / OFF)	"L" / "H"	"L" = 0V
\overline{NOR}	"LOW" / "HIGH" (ON / OFF)	"L" / "H"	"L" = 0V

7. NOMENCLATURE

7-1. Part Identification

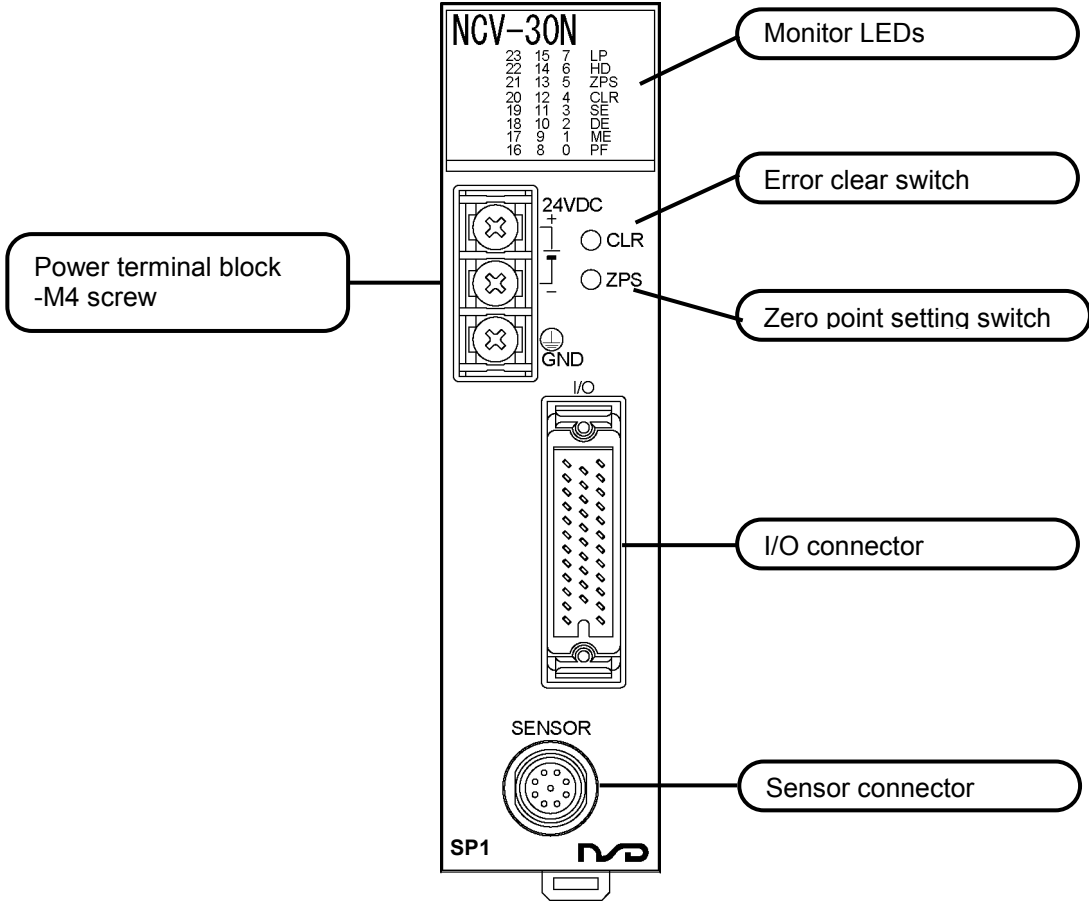

7-2. Function and Name of Display and Setting Area

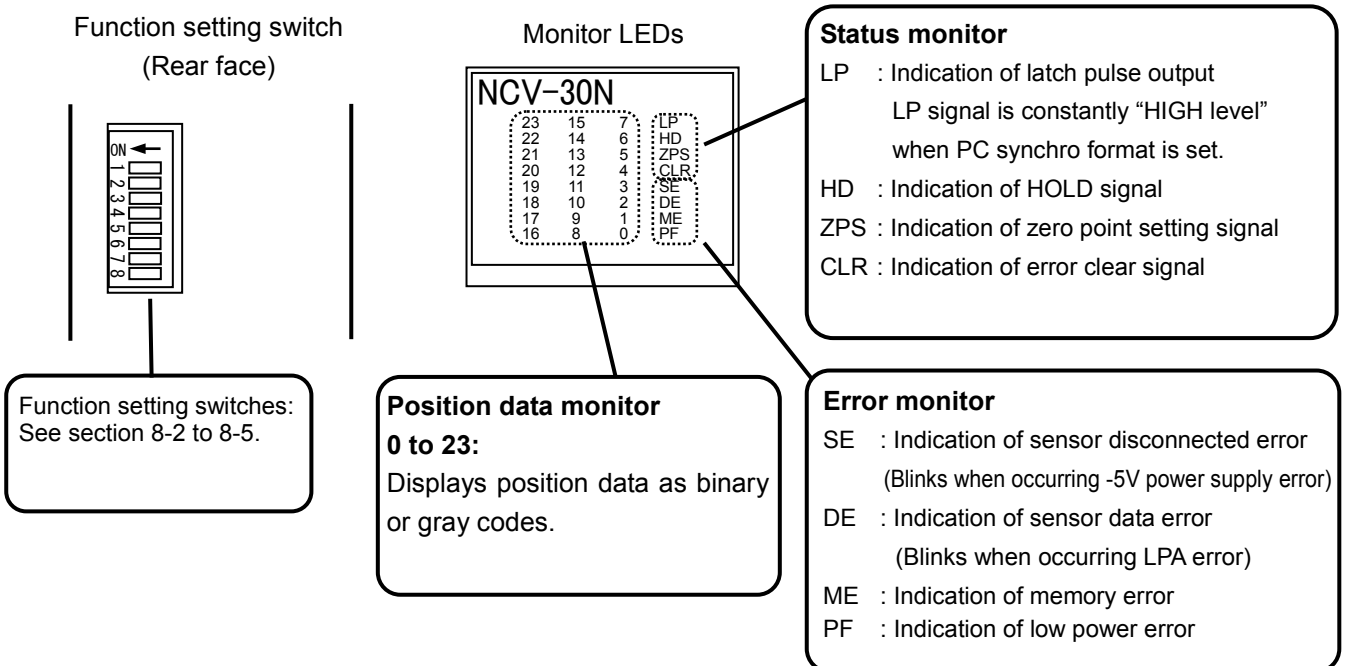

8. OPERATION

8-1. Operation Sequence

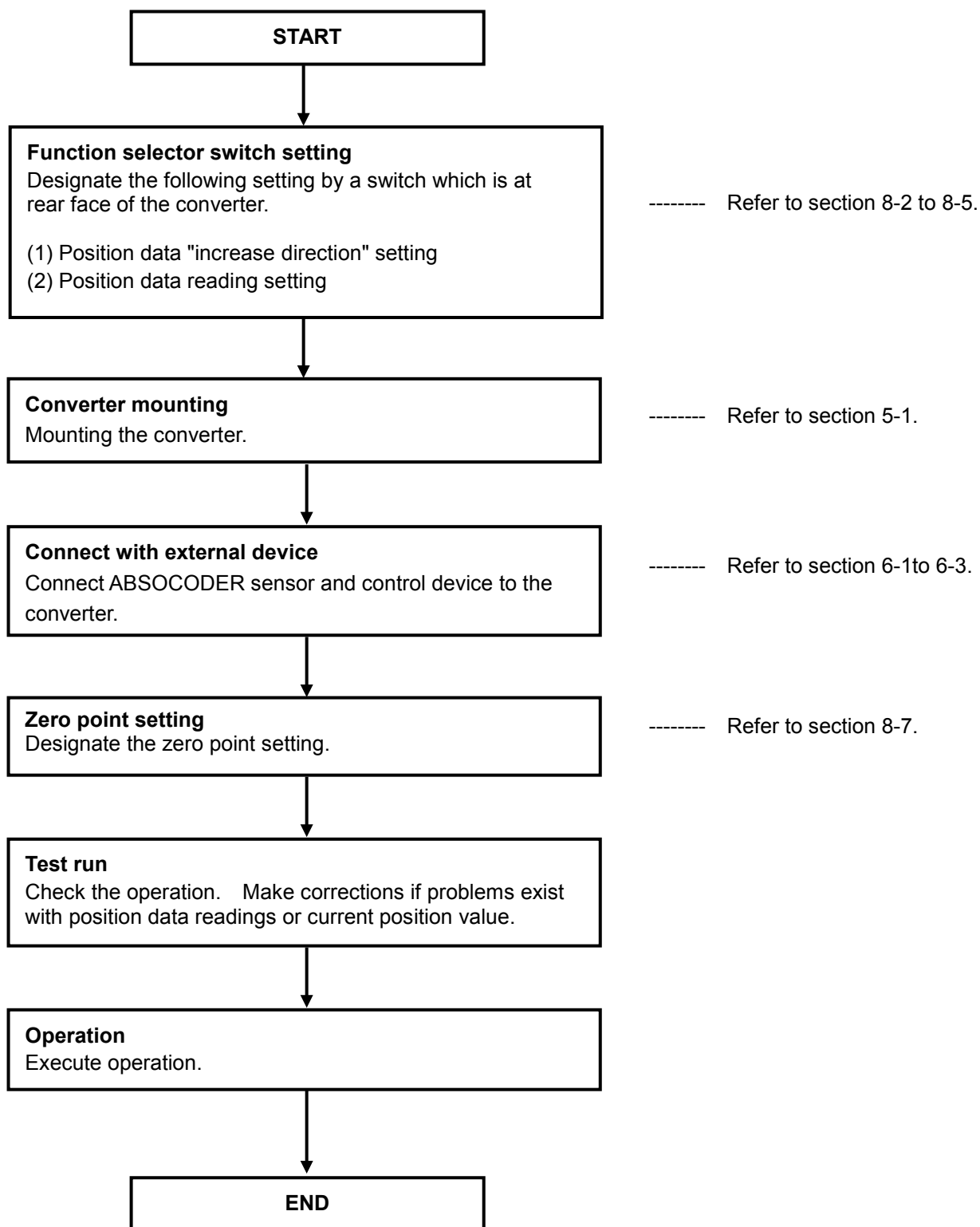

8-2. Settings of the Function Setting Switch

The following two position data reading formats are available:

- 1) Latch pulse (\overline{LP}) format...Reads position data which is updated regularly in synchronization with a latch pulse output signal from the converter.
- 2) HOLD (\overline{HD}) format...Reads position data while position data updates are stopped by a HOLD input signal.

When the \overline{LP} output signal reading format is used, a position data update period (cycle) can be selected which is appropriate for the host controller being used.

When the \overline{HD} input signal reading format is used, either a transparent format or a PC synchro format can be selected.

The desired position data output format can be select from three formats; binary code, sign magnitude code, minus zone "0" output.

The position data reading format can be set by the DIP switches on the rear face of the converter. The DIP switch settings are indicated in the next page.

The DIP switch settings are shown below.

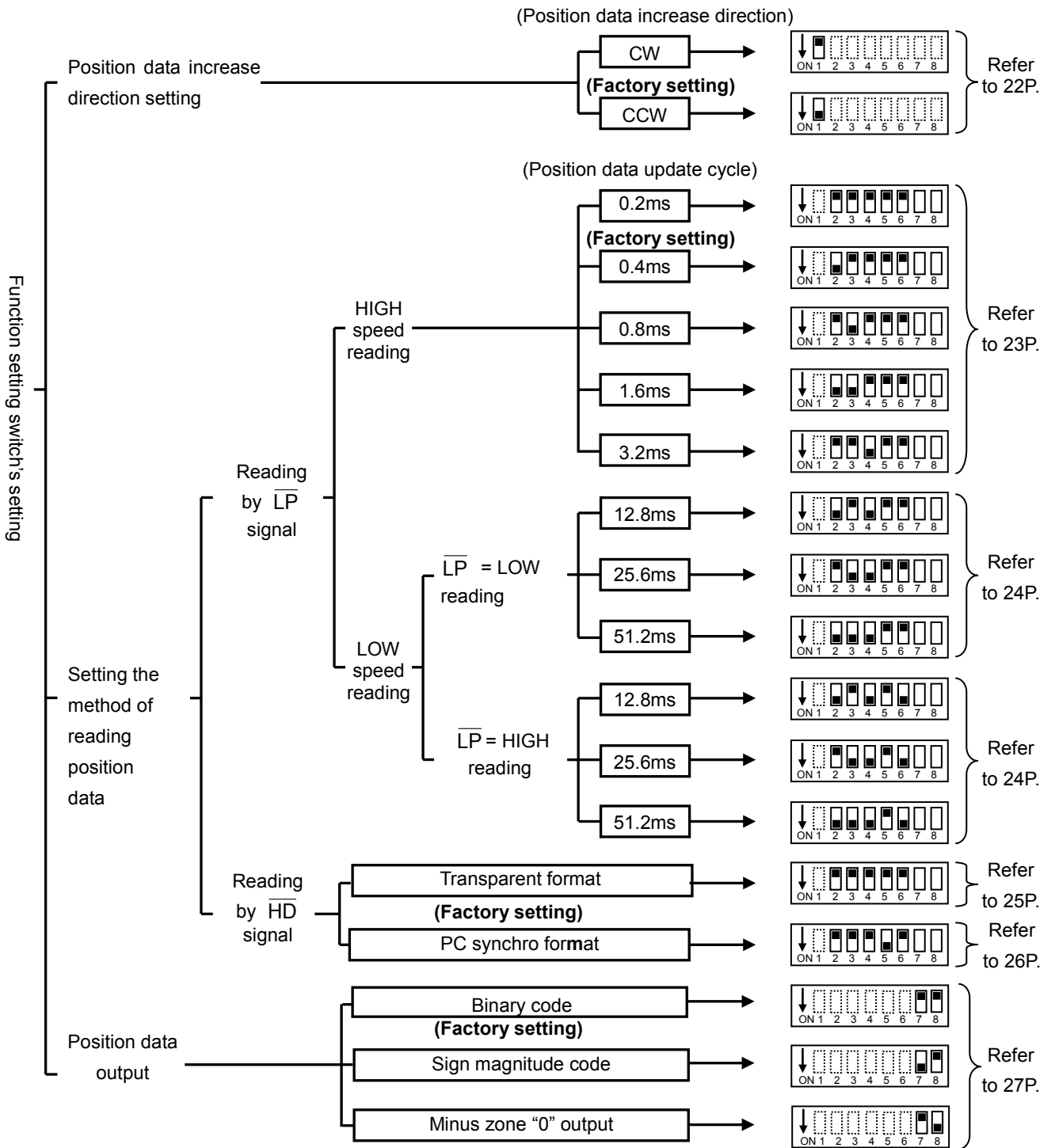

Important	<p align="center"><u>Cautions when using the function setting switches</u></p> <ul style="list-style-type: none"> -Always verify the function setting switch settings before beginning operation. -Never use function switch settings which are not indicated in the specifications. -Do not change function switch settings during operation, as this could result in injury.
------------------	---

8-3. Position Data "Increase Direction" Setting

The position data increases or decreases according to the ABSOCODER sensor's rod travel direction. The direction in which the position data increases is specified by a switch on the converter's rear face.

Switch setting

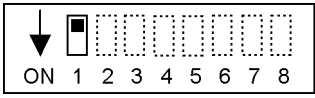
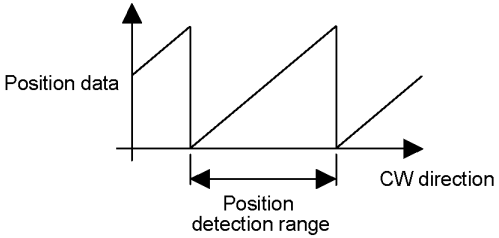
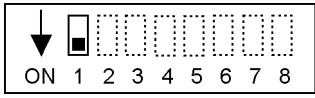
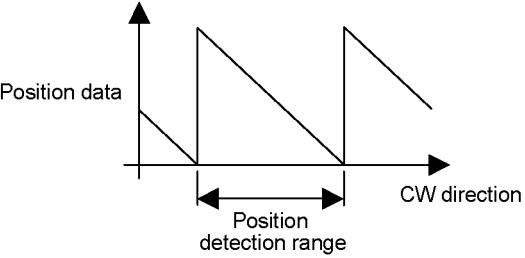
Increase direction	Switch setting	Alteration of the position data
CW (Factory setting)		
CCW		

<Travel direction of the rod>

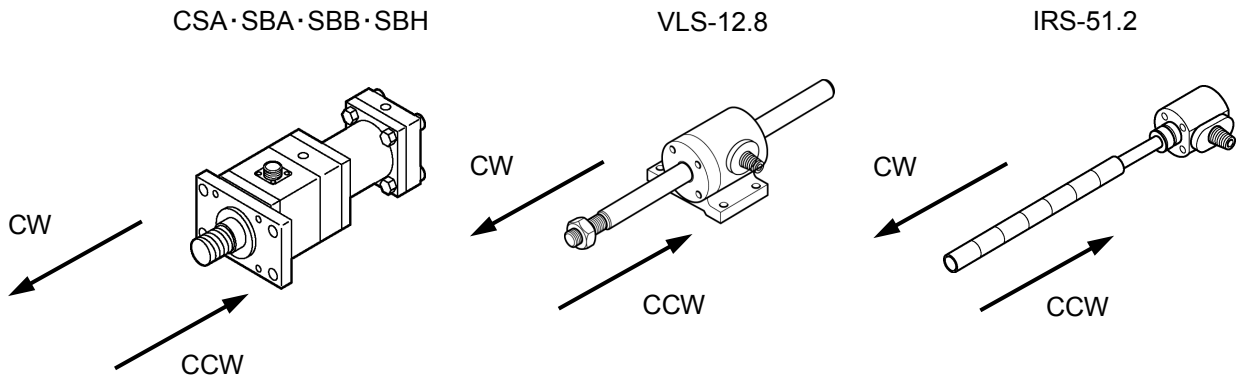

Important

Position data "increase direction" setting caution

Do not change the position data "increase direction" switch setting while the power is ON, as this could cause an accident.

8-4. Position Data Reading Setting

8-4-1. Position Data Reading by LP output

Position data reading is synchronized with the \overline{LP} output signal from the converter. Either high-speed or low-speed reading can be selected.

(1) High-speed reading

When high-speed reading is selected, the position data output is updated at the leading edge of the \overline{LP} output signal. It stabilizes at the trailing edge of the \overline{LP} output signal, so the position data should be read at that time.

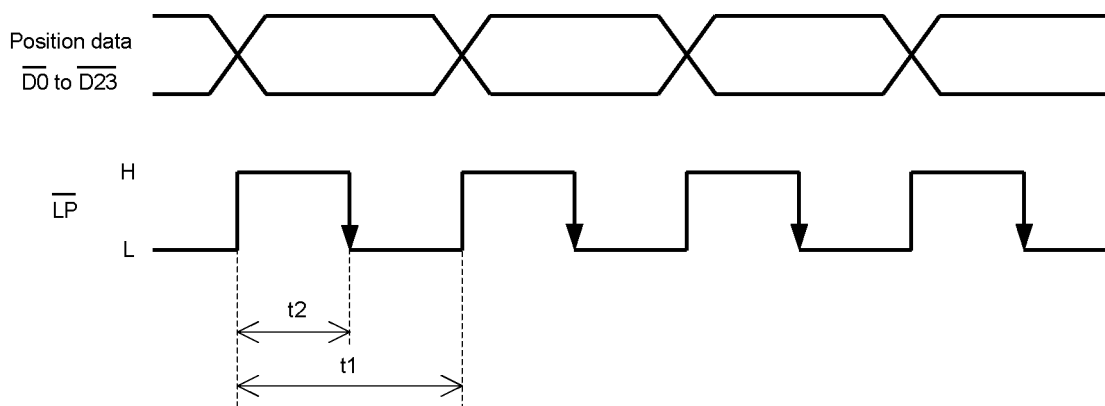

Position data update cycle	Switch setting	t1	t2
0.2ms (Factory setting)		0.2ms	0.07 to 0.10ms
0.4ms		0.4ms	0.17 to 0.20ms
0.8ms		0.8ms	0.37 to 0.40ms
1.6ms		1.6ms	0.77 to 0.80ms
3.2ms		3.2ms	1.57 to 1.60ms

(2) Low-speed reading (at \overline{LP} =LOW)

When low-speed reading (at \overline{LP} =LOW) is selected, the position data output is updated when the \overline{LP} output signal is HIGH. It stabilizes when the \overline{LP} output signal is LOW, so the position data should be read at that time.

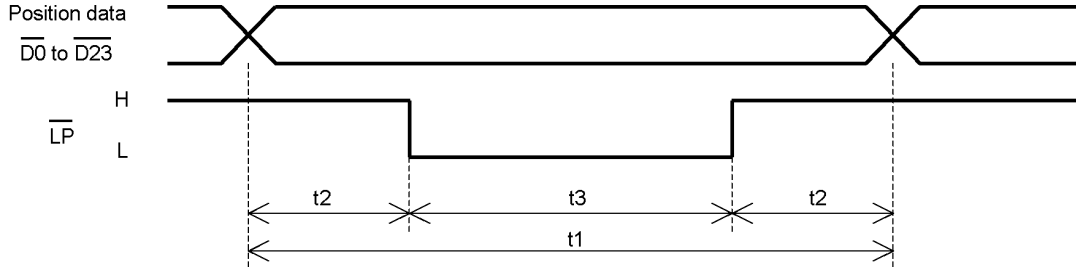

Position data update cycle	Switch setting	t1	t2	t3
12.8ms		12.8ms	3.2ms	6.4ms
25.6ms		25.6ms	6.4ms	12.8ms
51.2ms		51.2ms	12.8ms	25.6ms

(3) Low-speed reading (at \overline{LP} =HIGH)

When low-speed reading (at \overline{LP} =HIGH) is selected, the position data output is updated when the \overline{LP} output signal is LOW. It stabilizes when the \overline{LP} output signal is HIGH, so the position data should be read at that time.

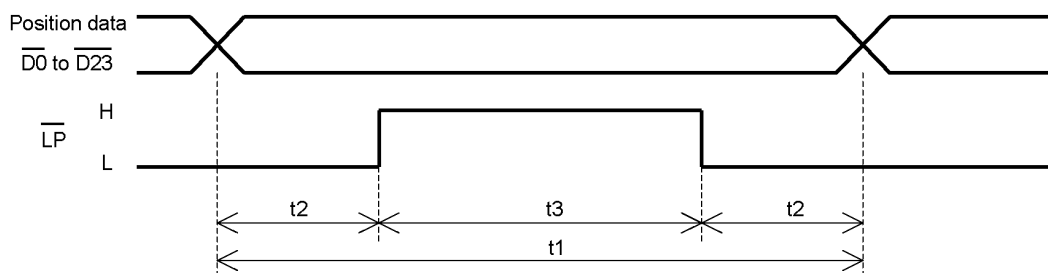

Position data update cycle	Switch setting	t1	t2	t3
12.8ms		12.8ms	3.2ms	6.4ms
25.6ms		25.6ms	6.4ms	12.8ms
51.2ms		51.2ms	12.8ms	25.6ms

8-4-2. Position Data Reading by HOLD (HD) Input

The HOLD input signal is used to HOLD position data outputs from the host controller. Either of the following two position data HOLD formats can be selected.

(1) Transparent format

Position data output updating is stopped by an HOLD input signal from the host controller (PLC, etc.). The position data should be read at that time.

Updating of the position data is stopped while the HOLD input signal is ON (L). Position data reading should be performed after waiting period "t1" following the HOLD input signal is ON.

When the HOLD input signal switches OFF (H), position data updates are synchronized with the \overline{LP} output signal. Next time, the "HOLD input signal" switches ON (L) in order to read the position data, please input the HOLD input signal after waiting period "t2".

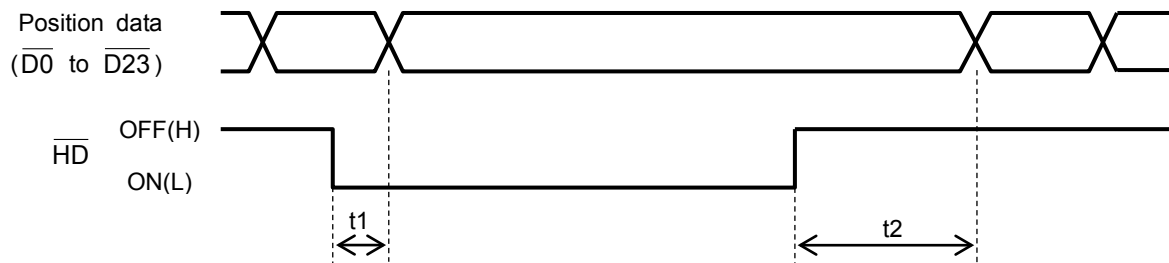

	Switch setting	t1	t2
Transparent format (Factory setting)		0.1ms	0.4ms

Important

Caution when the power supply turns ON

The position data output will be all OFF (H), if the converter is powered ON while the HOLD input signal is ON (L).

The HOLD input signal must be temporarily OFF (H) in order to output the position data.

(2) PC synchro format

Position data output updating occurs when the HOLD input signal status changes (leading edge or trailing edge), and is not synchronized with the LP output signal.

Position data reading should be performed after waiting period "t3" following the HOLD input signal status is changed by the host controller (PLC, etc.). In addition, the cycle of the HOLD signal status changes should be more than "t4".

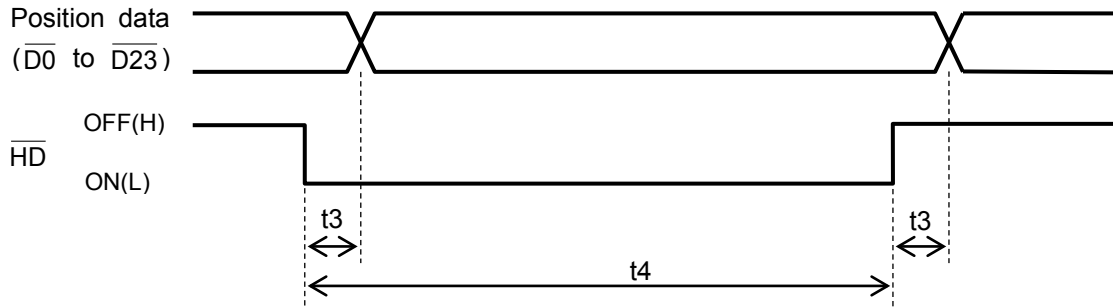

Note: \overline{LP} signal (latch pulse signal) is constantly "HIGH level" when PC synchro format is set.

	Switch setting	t3	t4
PC synchro format	<p>ON 1 2 3 4 5 6 7 8</p>	0.2ms	0.4ms

8-5. Position Data Output Format Setting

This setting applies for the NCV-30NBLC only.

Select the position data output format from the binary code, sign magnitude code, or minus zone "0" output.

Binary code output: Outputs 24-bit of binary code.

Sign magnitude code output: $\overline{D23}$ output changes to minus sign output. The minus sign output is ON when the machine position travels to the minus side.

$\overline{D0}$ to $\overline{D22}$ output is position data, and $\overline{D23}$ is minus sign output.

Minus zone "0" output: $\overline{D0}$ to $\overline{D23}$ outputs are fixed at 000000H when the machine position travels to the minus side. Moreover, the output is fixed at FFFFFFFH when the machine travels more than maximum value.

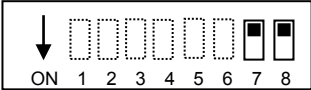
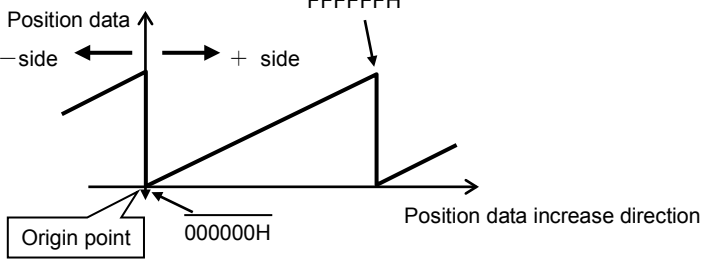
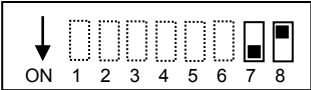
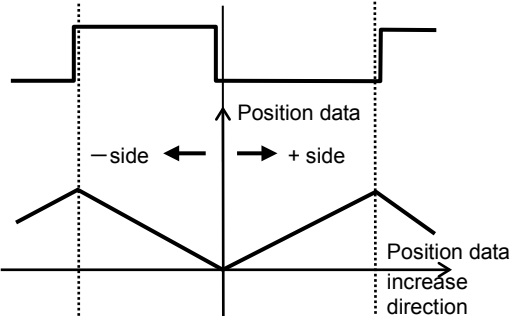
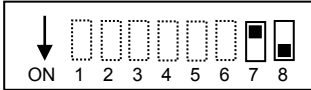
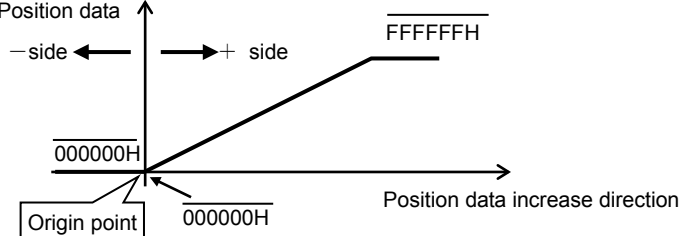
Output format Switch setting	Details
<p>Binary code format (Factory setting)</p> 	<p>$\overline{D0}$ to $\overline{D23}$: Position data</p> 
<p>Sign magnitude code format</p> 	<p>$\overline{D23}$: Minus sign bit</p> <p>ON OFF</p>  <p>$\overline{D0}$ to $\overline{D22}$: position data</p> <p>$\overline{D0}$ to $\overline{D23}$: output data FFFFFFFH 000000H 7FFFFFFH</p> <p>Variation status of minus sign near "0" and output data ($\overline{D0}$ to $\overline{D23}$) ... 800002H, 800001H, 000000H, 000001H, 0000002H ... (-2) (-1) (0) (1) (2)</p>
<p>Minus zone "0" output format</p> 	<p>$\overline{D0}$ to $\overline{D23}$: position data</p> 

8-6. System Ready Signal

The system ready signal indicates that the normal position data is output from the converter. The signal is “**LOW level**” when ABSOCODER sensor and converter operate normally. For your safety, read the position data when the system ready signal is “**LOW level**”.

The system ready signal is “**HIGH level**” in the following cases:

- The power supply is OFF.
- An error occurred.

For more details, refer to “10-2. Output State when Occurring an Error”

●Timing when the power turns ON

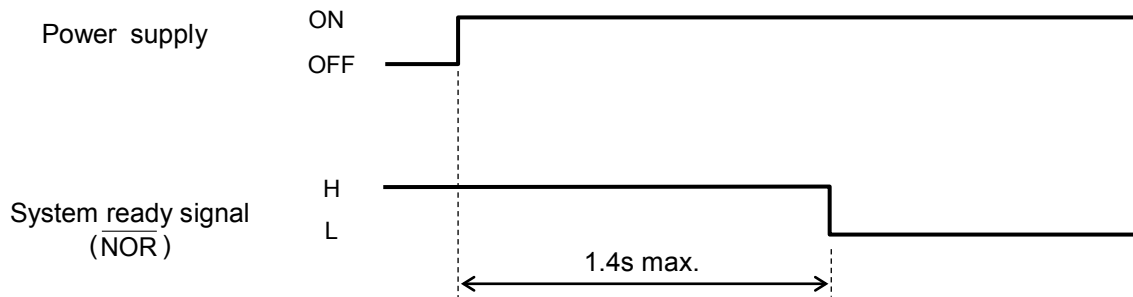

8-7. Zero Point Setting

A “zero point setting” refer to an operation in which the position data ($\overline{D0}$ to $\overline{D23}$) is set to “0”.

To set the zero point, move the ABSOCODER sensor’s rod to the zero point position.

After that, execute by using either the “ZPS” button on the front panel or the “ \overline{ZPS} ” external input signal.

Important

Zero point setting after the power-ON

Must do the zero point setting operation after the power-ON.

Do not forget this zero point setting operation after restoring from a power outage, especially.

8-7-1. Zero Point Setting Procedure

(1) Using the zero point setting button on the front panel

1. Move the machine to the zero-point position.
2. Verify that a normal status exists at the converter.
(“SE”, “DE”, “ME”, “PF” LEDs are OFF, and “ \overline{NOR} ” external output signal is “LOW level”.)
3. Press the zero point setting button on the front panel.

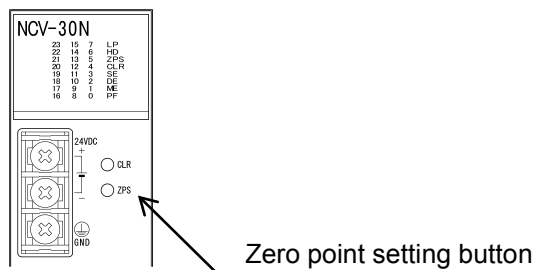

(2) Input the zero point setting signal

1. Move the machine to the zero-point position.
2. Verify that a normal status exists at the converter.
(“SE”, “DE”, “ME”, “PF” LEDs are OFF, and “ \overline{NOR} ” external output signal is “LOW level”.)
3. Input the zero point setting signal (\overline{ZPS}).

8-7-2. Timing of the Zero Point Setting when Using a Latch Pulse Signal

Indicates the timing of the zero point setting when using a latch pulse signal.

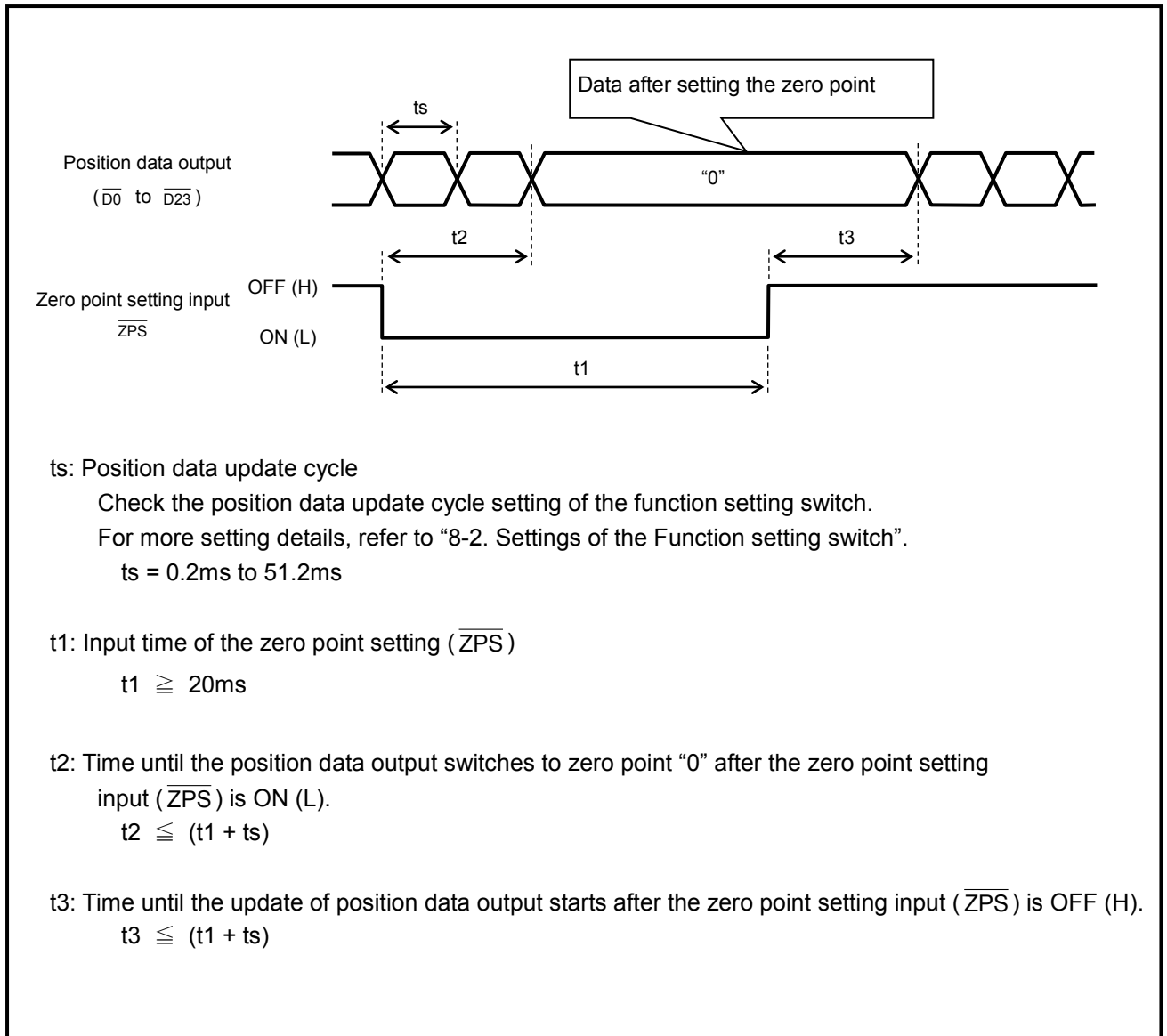

Important

1. The zero point setting input must be ON 20ms or more.
2. The position data output is not updated until the zero point setting input is OFF.
It is fixed at "0".

8-7-3. Timing of the Zero Point Setting when Using a HOLD Signal

Indicates the timing when setting either transparent format or PC synchro format of HOLD input.

(1) Transparent format

In the case of setting the zero point during HOLD input is ON (L) by transparent format, turning OFF(H) HOLD input allows outputting the position data after setting the zero point.

If the zero point setting is input when HOLD signal is OFF state, the timing will be same procedure as "8-7-2. Timing of the Zero Point Setting when Using a Latch Pulse Signal".

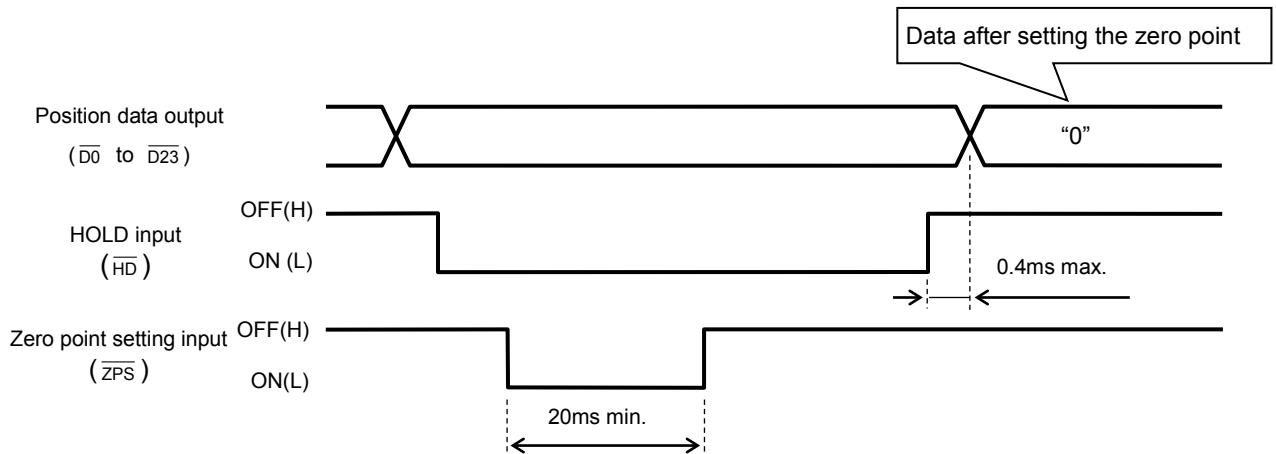

Important

Even if the zero point setting input turns ON during HOLD input is ON, the position data won't be updated. The position data must be read after HOLD input is OFF.

(2) PC synchro format

In the case of setting the zero point by PC synchro format, changing HOLD input allows outputting the position data after setting the zero point.

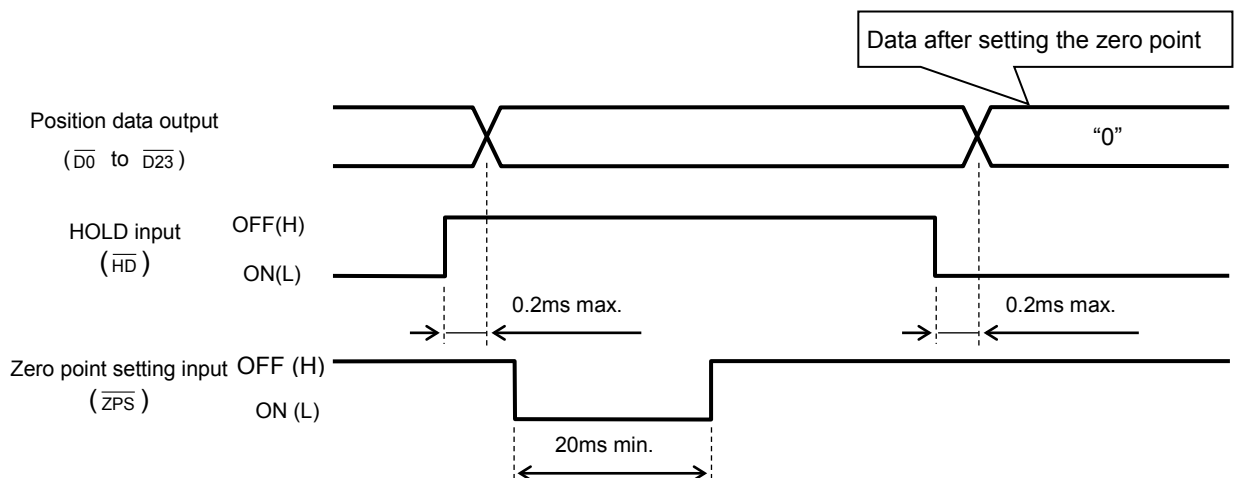

Important

The position data output is not updated only by turning ON the zero point setting input. The position data must be read after switching HOLD input.

8-8. Error Clear

Describes the error clear procedure in this chapter.

(1) Using the error clear button on the front panel

Press the error clear button on the front panel.

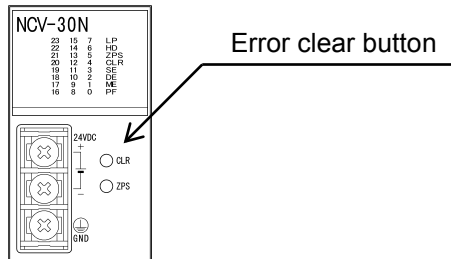

(2) Input the error clear signal

Input the error clear signal ($\overline{\text{CLR}}$).

Important

- The error clear input must be ON 20ms or more.
- The error clear signal must be turned OFF after clearing the error.

Indicates the timing of system ready output when inputting the error clear.

For your safety, read the position data when the system ready signal is “**LOW level**”.

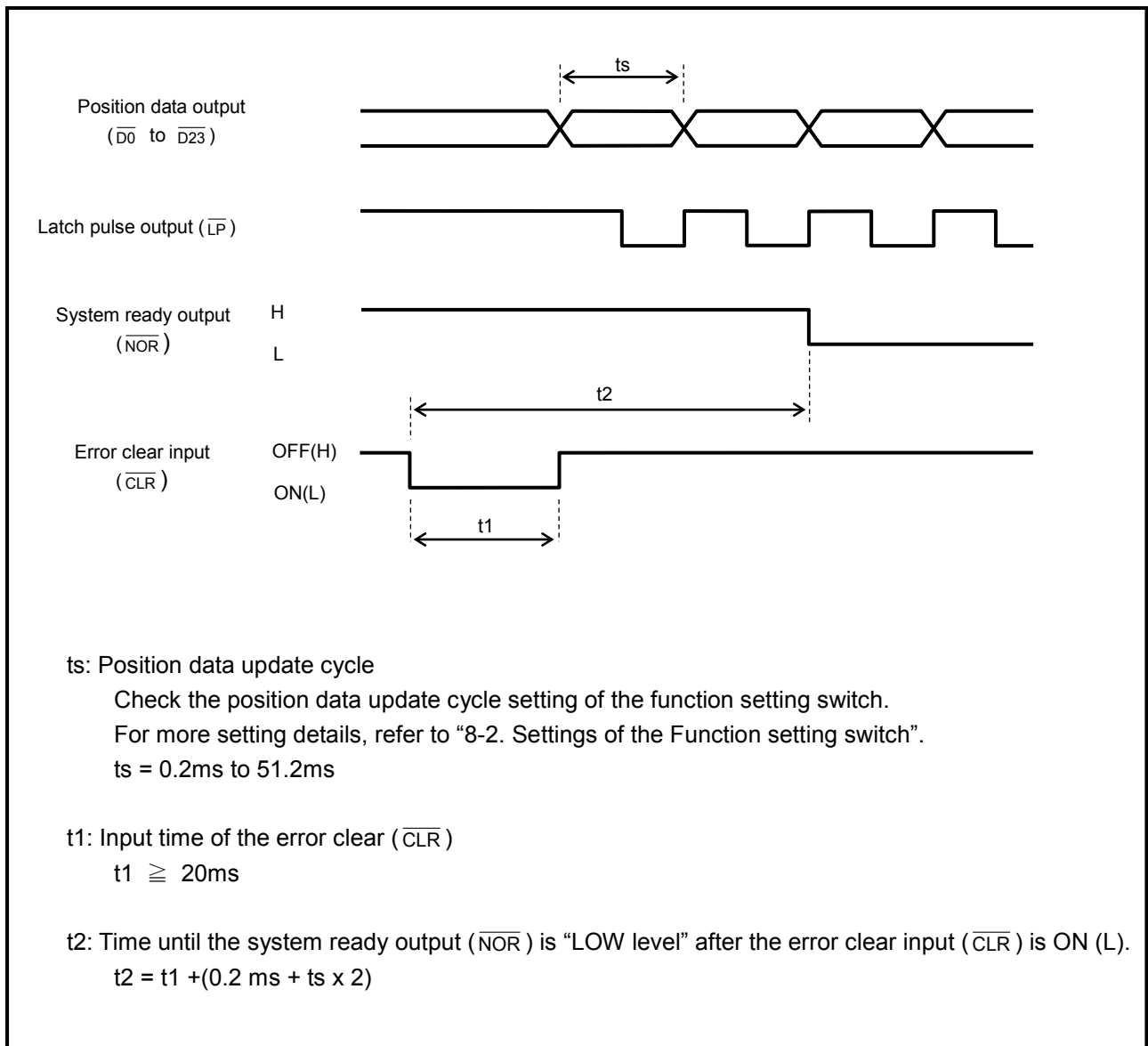

9. INSPECTIONS

The inspection should be conducted once every 6 months to a year.

Any inspected items which do not satisfy the criteria shown below should be repaired.

Inspection item	Inspection Description	Criteria	Remark
Power supply	Measure the voltage at the power supply terminal of the converter.	Within 21.6 to 26.4VDC	Tester
Ambient Conditions	Check the ambient temperature.	ABSOCODER sensor Refer to "ABOSOCODER specification". Converter: 0 to +55°C	Thermometer
	There should be no accumulation of dust.	None	
Mount Conditions	Verify that the sensor is securely mounted.	There should be no looseness.	Visual Inspection
	Verify that the sensor rod is securely coupled to the machine shaft.	There should be no looseness.	
	Check for severed cables.	Cable should appear normal.	
	Verify that the sensor cable connector is plugged in all the way.	There should be no looseness.	
	Verify that the I/O connector is plugged in all the way.	There should be no looseness.	

10. TROUBLESHOOTING

The causes and corrective actions for errors that may occur during NCV-30 operation are described below.

10-1. Display and Countermeasure when an Error Occurred

NCV-30 has LED for the error monitor. Error contents are checked by LED light.
Refer to the following list and implement appropriate countermeasures.

Important
The zero point setting must be done after clearing the error.

● Lists of the error monitors, probable causes, and error cancel procedures

Error monitor	Name	Probable cause	Error cancel procedures
"SE" LED is ON	Sensor disconnected error	Sensor connector is disconnected or loose	After removing an error cause, clear the error by either way: - Press CLR button. - Input the error clear signal from external.
		Sensor cable is severed.	Replace the sensor cable. For more details, refer to "10-3".
		ABSOCODER sensor failure	Replace the ABSOCODER sensor. For more details, refer to "10-3".
		Converter failure	Replace the converter. For more details, refer to "10-3".
"SE" LED blinks	-5V power supply error	The power supply inside of the converter for sensor is broken down.	Replace the converter. For more details, refer to "10-3".
"DE" LED is ON	Sensor data error	Sensor connector is loose.	After removing an error cause, clear the error by either way: - Press CLR button. - Input the error clear signal from external.
		ABSOCODER sensor was shocked excessively.	
		Wiring has a noise source	Replace the sensor cable. For more details, refer to "10-3".
		Sensor cable is severed.	
"DE" LED blinks	LPA error	The sensor circuit inside of the converter is broken down.	Replace the converter. For more details, refer to "10-3".
"ME" LED blinks	Memory error	Memory data has been changed due to external noise, etc.	After moving the machine to zero point, clear the error by either way: - Press ZPS button. - Input the zero point setting signal from external.
"PF" LED is ON	Low power error	Voltage drop of 24VDC power supply	After removing an error cause, clear the error by either way: - Press CLR button. - Input the error clear signal from external. - Turn the power OFF and then ON again.
		Instantaneous power failure of 24VDC power supply	
All LED is OFF	—	Converter failure	Replace the converter. For more details, refer to "10-3".

● Other error contents

Error contents	Probable cause	Error cancel procedures
Zero point deviation	Coupling of ABSOCOER sensor rod and the machine is loose.	Secure the coupling / mounting.
	ABSOCODER sensor mounting is loose.	
	" \overline{ZPS} "(the external input signal) is ON.	Check the signal status.
Incorrect position data output	\overline{LP} output signal and position data reading timing are improper.	Correct the reading timing.
	\overline{HD} input signal and position data reading timing are improper	
	The wiring of the output signal has problems.	Repair the wiring.
Position data HOLD doesn't occur.	The function setting switch is incorrect.	Change the setting.
	The voltage of the power supply for input and output is out of prescribed range.	Supply the correct power voltage. 10.8V to 26.4VDC
	The wiring of the input signal has problems.	Repair the wiring.
No position data output	The voltage of the power supply for input and output is out of prescribed range.	Supply the correct power voltage. 10.8V to 26.4VDC
	The function setting switch is incorrect.	Change the setting.
	" \overline{ZPS} "(the external input signal) is ON.	Check the signal status.
	" \overline{HD} "(the external input signal) is ON.	
	The wiring of the output signal has problems.	Repair the wiring.

10-2. Output State when Occurring an Error

Indicates the state of output signal when occurring an error.

Output Item	Position data output $\overline{D0}$ to $\overline{D23}$	Latch pulse output \overline{LP}	System ready output \overline{NOR}
“SE” LED is ON Sensor disconnected error	The data before the error occurs is maintained.	*1 HIGH level	HIGH level
“SE” LED is blinking -5V power supply error			
“DE” LED is ON Sensor data error			
“DE” LED is blinking LPA error			
“PF” LED is ON Low power error			
“ME” LED is ON Memory error	Truth value “0”		

Note

*1: \overline{LP} (latch pulse output) is “LOW level” when setting is “Low speed reading and \overline{LP} = HIGH reading”.
Other cases, \overline{LP} is “HIGH level”.

10-3. Procedure Contents after Replacing

Implement the following measures after replacing the converter, ABSOCODER sensor, and sensor cable.

Replacing contents	Countermeasure
In the case of replacing ABOSOCODER sensor	Implements the following measures after the replacement. 1. Cancels an error either one of the following methods. - Press CLR button. - Input the error clear signal from external. Refer to “8-8” for the procedure of error clear.
In the case of replacing the sensor cable	2. Sets the zero point either of the following methods after the machine position is moved to the origin point. - Press ZPS button. - Input the zero point setting signal from external. Refer to “8-7” for the procedure of zero position setting
In the case of replacing the converter	Implements the following measures after the replacement. 1. Sets the zero point either of the following methods after the machine position is moved to the origin point. - Press ZPS button. - Input the zero point setting signal from external. Refer to “8-7” for the procedure of zero position setting

- MEMO -

10-4. ABSOCODER Check Lists

- Applicable ABSOCODER models
CSA, SBA, SBB, SBH

Contact our sales representative for VLS-12.8 and IRS-51.2.

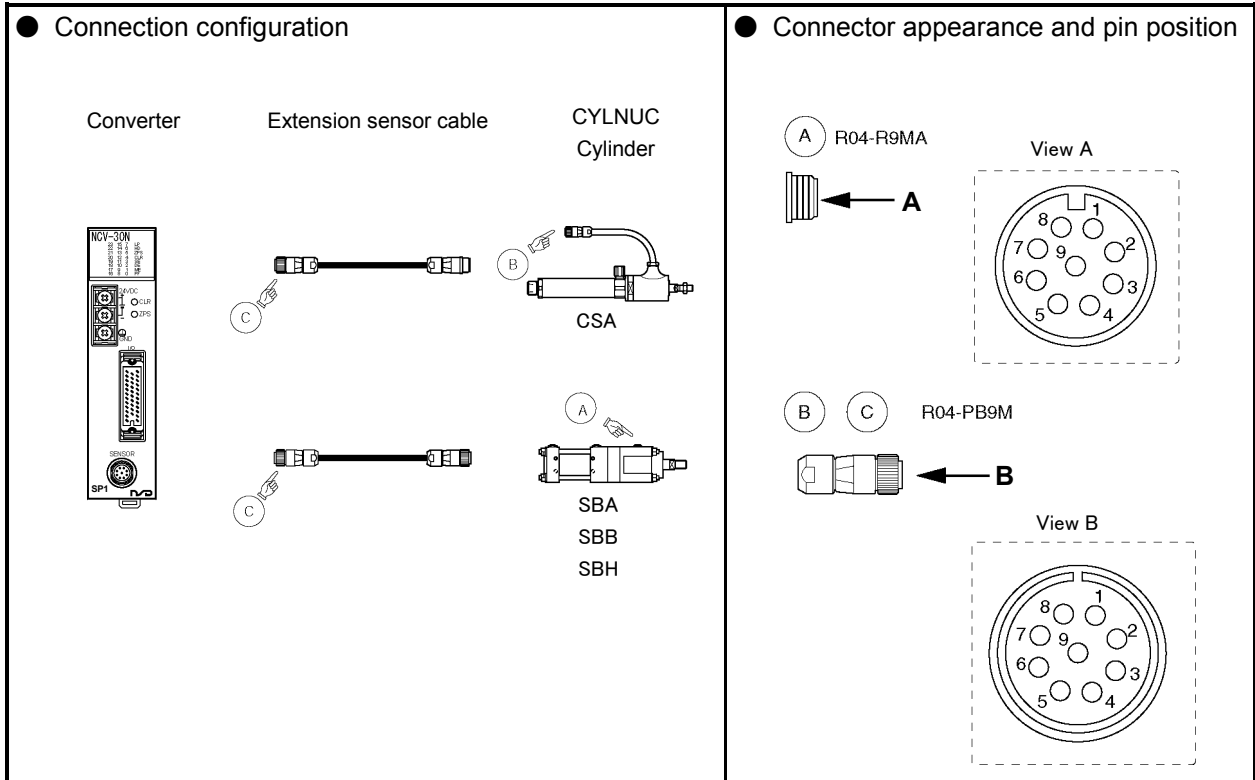

Checks at Point B should be carried out with Point A (or Point B) connected.

- Connector pin position and standard coil resistance ranges (at 25°C)

Connector pin No.	Signal name	Wiring color	Standard coil resistance [Ω]						
			CSA		SBA / SBB / SBH				
			ϕ 20	ϕ 40	ϕ 40	ϕ 50	ϕ 63	ϕ 80	ϕ 100
1	SIN+	Brown	61 to 136	71 to 146	20 to 60	23 to 63	25 to 65	30 to 70	42 to 82
2	SIN-	Red							
3	-COS+	Orange	61 to 136	71 to 146	20 to 60	23 to 63	25 to 65	30 to 70	42 to 82
4	-COS-	Yellow							
5	OUT1+	Green	185 to 215	203 to 233	57 to 77	61 to 81	67 to 87	81 to 101	100 to 128
6	OUT1-	Blue							
7	—	—	—	—	—	—	—	—	—
8	—	—	—	—	—	—	—	—	—
9	Shield	Shield	—	—	—	—	—	—	—
—	—	—	—	—	—	—	—	—	—

The above standard coil resistance ranges are referential data to assist wiring disconnection diagnosis and are not product specification values. There may be no wiring disconnection even when the resistance measurement is out of the standard resistance range.

● Circuit resistance check

[Measurement method]

Measure resistance at Point A, B, or C using a circuit tester or other appropriate device.
If the connector is off, identify the line by the wiring color.

[Check details]

Refer to the previous page for the connector pin number.

Check position	Criterion	Check position	Criterion
Between brown and red	The measured value should be in the range of the standard coil resistance. *1	Between brown and orange, green, shield	∞
Between orange and yellow		Between orange and green, shield	
Between green and blue		Between green and shield	
		Between frame and each wire	

*1: If checks are done at Point C, the measurement value is [Standard coil resistance + extension sensor cable resistance (cable length (m) x 0.2 (Ω))].
The resistance value of the NSD special cable is 0.2Ω/m (loop resistance).
Consider resistance variations due to temperature, which, relative to the standard temperature (25°C), increases 0.4% when the temperature rises 1°C and decreases 0.4% when the temperature falls 1°C.

● Insulation check

[Measurement method]

Measure using a 500 VDC insulation tester.

[Check details]

Refer to the previous page for the connector pin number.

Check position	Criterion
Between brown and orange, green, shield	10MΩ or more
Between orange and green, shield	
Between green and shield	
Between frame and each wire	

 **NOTES**

1. Make sure to disconnect the CYLNUC Cylinder from the NCV-30 before carrying out insulation checks.
2. If there is a risk that energization may cause damages to the electronic circuits in and around the machine, remove the CYLNUC Cylinder from the machine.
3. After completing the checks, short-circuit between the pins to discharge remaining voltage before connecting the CYLNUC Cylinder to the NCV-30.



NSD Group

Manufacturer

NSD Corporation 3-31-28, OSU, NAKA-KU, NAGOYA, JAPAN 460-8302

Distributor

NSD Trading Corporation 3-31-23, OSU, NAKA-KU, NAGOYA, JAPAN 460-8302

Phone: +81-52-261-2352 Facsimile: +81-52-252-0522

URL: www.nsdcorp.com E-mail: foreign@nsdcorp.com

Copyright©2020 NSD Corporation All rights reserved.