

INVERTER

FR-E800

Instruction Manual (Communication)

Compact, high functionality inverters

Chapter 1 Introduction	6
1.1 Product checking	8
1.2 Related manuals	10
Chapter 2 Ethernet Communication	12
2.1 Outline	12
2.2 Wiring	13
2.2.1 System configuration example	13
2.2.2 Network configuration	13
2.2.3 Network components	13
2.3 Ethernet cable connection	15
2.3.1 Wiring method (Ethernet model / safety communication model)	15
2.3.2 Wiring method (IP67 model)	16
2.3.3 Wiring precautions	17
2.4 Initial setting for Ethernet communication	18
2.5 CC-Link IE TSN	19
2.5.1 Outline	19
2.5.2 CC-Link IE TSN configuration	22
2.5.3 Initial setting for CC-Link IE TSN	28
2.5.4 Parameters related to CC-Link IE TSN	28
2.6 CC-Link IE Field Network Basic	59
2.6.1 Outline	59
2.6.2 CC-Link IE Field Network Basic configuration	59
2.6.3 Initial setting for CC-Link IE Field Network Basic	62
2.6.4 Parameters related to CC-Link IE Field Network Basic	65
2.6.5 Group number setting	86
2.7 MODBUS/TCP	88
2.7.1 Outline	88
2.7.2 Initial setting for MODBUS/TCP	88
2.7.3 Parameters related to MODBUS/TCP	91
2.8 BACnet/IP	107
2.8.1 Outline	107
2.8.2 Initial setting for BACnet/IP	107
2.8.3 Parameters related to BACnet/IP	110
2.9 MELSOFT / FA product connection	123
2.9.1 Outline	123
2.9.2 Initial setting for MELSOFT / FA product connection	123
2.9.3 Parameters related to MELSOFT / FA product connection	124
2.10 SLMP	126
2.10.1 Outline	126

2.10.2	Initial setting for SLMP	126
2.10.3	Parameters related to SLMP	127
2.11	EtherNet/IP	143
2.11.1	Outline	143
2.11.2	EtherNet/IP configuration	144
2.11.3	Initial setting for EtherNet/IP	145
2.11.4	Parameters related to EtherNet/IP	147
2.11.5	Object map definitions	150
2.11.6	Object map	150
2.12	PROFINET	171
2.12.1	Outline	171
2.12.2	PROFINET configuration	173
2.12.3	Initial setting for PROFINET	173
2.12.4	Parameters related to PROFINET	174
2.12.5	Data Exchange	175
2.13	EtherCAT	196
2.13.1	Outline	196
2.13.2	Parameters related to EtherCAT	197
2.13.3	EtherCAT state machine (ESM)	199
2.13.4	PDO (Process Data Object) communication	200
2.13.5	CoE object dictionary	202
2.13.6	Operation at fault occurrence	218
2.13.7	Programming example	218
2.14	Backup/restore	220
2.14.1	Outline	220
2.14.2	Initial setting for the backup/restore function	220
2.15	Inverter-to-inverter link function	222
2.16	Ethernet communication parameters	225

Chapter 3 RS-485 Communication 232

3.1	Outline	232
3.2	Wiring	232
3.2.1	Wiring procedure	232
3.2.2	Connected device	232
3.3	Wiring of PU connector	234
3.4	Mitsubishi inverter protocol (computer link communication)	236
3.5	MODBUS RTU	249
3.6	BACnet MS/TP	262

Chapter 4 Other Communication Options	278
4.1 USB device communication	278
4.2 Automatic connection with GOT	280
Chapter 5 Common Settings	282
Chapter 6 Appendix	290
6.1 How to check specification changes	290
6.1.1 Details of specification changes	290

CHAPTER 1 Introduction

1.1	Product checking	8
1.2	Related manuals	10

1 Introduction

The contents described in this chapter must be read before using this product.

Always read the instructions before use.

◆ Abbreviations

Item	Description
PU	Operation panel, parameter unit (FR-PU07), LCD operation panel (FR-LU08), and enclosure surface operation panel (FR-PA07)
Parameter unit	Parameter unit (FR-PU07), LCD operation panel (FR-LU08), and enclosure surface operation panel (FR-PA07)
Inverter	Mitsubishi Electric FR-E800 series inverter
E800	Standard model (RS-485 + SIL2/PLd functional safety)
E800-E	Ethernet model (Ethernet + SIL2/PLd functional safety)
E800-SCE	Safety communication model (Ethernet + SIL3/PLe functional safety)
E806	IP67 model (Ethernet + SIL3/PLe functional safety + IP67)
FM type inverter	Standard model with terminal FM (pulse output)
AM type inverter	Standard model with terminal AM (voltage output)
Vector control compatible option	FR-A8AP E kit
Pr.	Parameter number (Number assigned to function)
PU operation	Operation using the PU (operation panel / parameter unit)
External operation	Operation using the control circuit signals
Combined operation	Combined operation using the PU (operation panel / parameter unit) and External operation
Mitsubishi Electric standard efficiency motor	SF-JR
Mitsubishi Electric constant-torque motor	SF-HRCA
Mitsubishi Electric high-performance energy-saving motor	SF-PR
Mitsubishi Electric high-performance energy-saving motor with encoder	SF-PR-SC
Mitsubishi Electric Vector control dedicated motor	SF-V5RU
Mitsubishi Electric geared motor	GM-[]
Mitsubishi Electric inverter-driven geared motor for encoder feedback control	GM-DZ, GM-DP
Mitsubishi Electric PM motor	MM-GKR, EM-A

◆ Digital characters and their corresponding printed equivalents

0	1	2	3	4	5	6	7	8	9	A	B	C
0	1	2	3	4	5	6	7	8	9	A	B	C
D	E	F	G	H	I	J	K	L	M	N	O	P
d	e	f	g	h	i	j	k	l	m	n	o	p
Q	R	S	T	U	V	W	X	Y	Z	-	-	
q	r	s	t	u	v	w	x	y	z	-	-	

◆ Trademarks

- MODBUS is a registered trademark of SCHNEIDER ELECTRIC USA, INC.
- BACnet is a registered trademark of the American Society of Heating, Refrigerating and Air-Conditioning Engineers (ASHRAE).
- DeviceNet and EtherNet/IP are registered trademarks of ODVA (Open DeviceNet Vendor Association, INC).
- PROFIBUS and PROFINET are either trademarks or registered trademarks of PROFIBUS & PROFINET International.
- CC-Link IE TSN and CC-Link IE Field Network Basic are registered trademarks of CC-Link Partner Association.

- EtherCAT® is registered trademark and patented technology, licensed by Beckhoff Automation GmbH, Germany.
- Other company and product names herein are either trademarks or registered trademarks of their respective owners.

◆ Notes on descriptions in this Instruction Manual

- Connection diagrams in this Instruction Manual appear with the control logic of the input terminals as sink logic, unless otherwise specified. (Refer to the FR-E800 Instruction Manual (Connection) for the switching of the control logic of the inverter.)

◆ Precautions

- Some of the communication protocols and the plug-in options cannot be used together as shown in the following table. For the application and protocol settings, refer to [page 226](#).

	CC-Link IE TSN	CC-Link IE Field Network Basic	BACnet/IP	EtherNet/IP	PROFINET	EtherCAT	CC-Link (when the FR-A8NC E kit is installed)	PROFIBUS-DP (when the FR-A8NP E kit is installed)	DeviceNet (when the FR-A8ND E kit is installed)
CC-Link IE TSN	—	x		x	x	x	x		
CC-Link IE Field Network Basic	x	—				x	x		
BACnet/IP			—		x	x			
EtherNet/IP	x			—	x	x			
PROFINET	x		x	x	—	x			
EtherCAT	x	x	x	x	x	—	x	x	x
CC-Link (when the FR-A8NC E kit is installed)	x	x				x	—	x	x
PROFIBUS-DP (when the FR-A8NP E kit is installed)						x	x	—	x
DeviceNet (when the FR-A8ND E kit is installed)						x	x	x	—

NOTE

- FR Configurator2 can be used for any communication protocol or plug-in option.

1.1 Product checking

◆ Inverter model

FR-E8 2 0 - 0008 E PA

A B C D E F G H

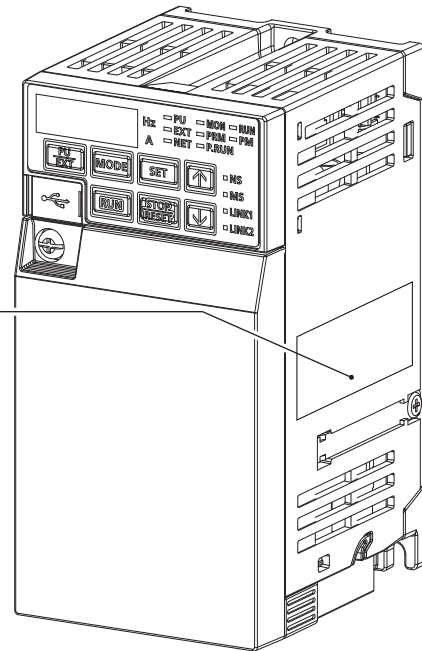
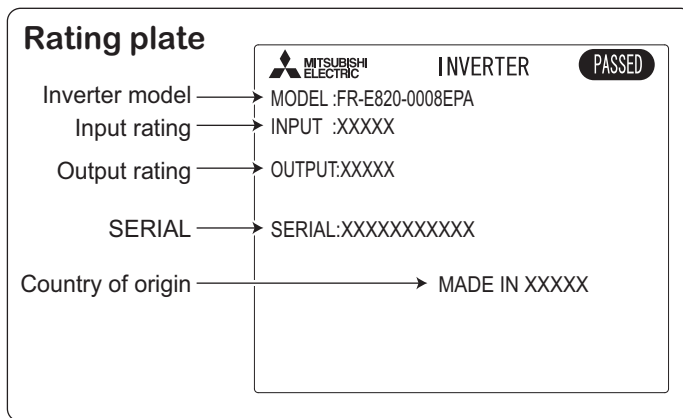

- A: The voltage class is shown.

Symbol	Voltage class
1	100 V class
2	200 V class
4	400 V class
6	575 V class

- B: The protective structure is shown.

Symbol	Protective structure
0	Open type (IP20)
6	Enclosed type (IP66/IP67, UL Type 4X, indoor use only)

- C: The number of phases of the power source is shown.

Symbol	Description
None	Three-phase input
S	Single-phase input
W	Single-phase input (double voltage output)

- D: The applicable motor capacity or the inverter rated current is shown.

Symbol	Description
0.1K to 22K	Applicable motor capacity (ND) (kW)
0008 to 0900	Inverter rated current (ND) (A)

- E: The communication type and the functional safety specification are shown.

Symbol	Communication / functional safety
None	RS-485 + SIL2/PLd
E	Ethernet + SIL2/PLd
SCE	Ethernet + SIL3/PLe

- F: The output specification for monitoring and the rated frequency are shown for the standard model, and the communication protocol group is shown for the Ethernet model, safety communication model, and IP67 model. The control logic is fixed to the source logic for the safety communication model and IP67 model.

Symbol	Monitoring/protocol specification	Rated frequency (initial setting)	Control logic	
			Input signal (initial status)	Safety stop signal
-1	Pulse (terminal FM)	60 Hz	Sink logic	Source logic (fixed)
-4	Voltage (terminal AM)	50 Hz	Source logic	
-5	Voltage (terminal AM)	60 Hz	Sink logic	
PA	Protocol group A (CC-Link IE TSN, CC-Link IE Field Network Basic, MODBUS/TCP, Ethernet/IP, and BACnet/IP)	60 Hz	Sink logic	
PB	Protocol group B (CC-Link IE TSN, CC-Link IE Field Network Basic, MODBUS/TCP, and PROFINET)	50 Hz	Sink logic / source logic ^{*1}	
PC ^{*2}	Protocol group C (EtherCAT)	50 Hz	Sink logic / source logic ^{*1}	

*1 The initial status of the control logic differs depending on the inverter model.
Sink logic for the models indicated with the applicable motor capacity (kW)
Source logic for the models indicated with the rated current (A)

*2 Available for the Ethernet model and the safety communication model.

- G: Availability of circuit board coating / plated conductors / power ON/OFF switch is shown.

Symbol	Circuit board coating ^{*1}	Plated conductor	Power ON/OFF switch
None	Without coating	Without plated conductors	Without switch
-60	With coating	Without plated conductors	Without switch
-06 ^{*2}	With coating	With plated conductors	Without switch
-S6 ^{*3}	With coating	Without plated conductors	With switch

*1 Conforming to IEC 60721-3-3:1994 3C2

*2 Applicable for the FR-E820-0470(11K) or higher, and the FR-E840-0380(18.5K) or higher.

*3 IP67 model only.

- H: Availability of an EMC filter is shown.

Symbol	EMC filter
None	Without filter
C2 ^{*1}	With filter (Class C2)

*1 IP67 model only.

NOTE

- In this Instruction Manual, the inverter model name consists of the applicable motor capacity and the rated current.
(Example) FR-E820-0008(0.1K)

◆ How to read the SERIAL number

Rating plate example

Symbol Year Month Control number

SERIAL

The SERIAL consists of two symbols, three characters indicating the production year and month, and six characters indicating the control number.

The last two digits of the production year are indicated as the Year, and the Month is indicated by 1 to 9, X (October), Y (November), or Z (December).

1.2 Related manuals

When using this inverter for the first time, prepare the following manuals as required and use the inverter safely. The latest version of e-Manual Viewer and the latest PDF manuals can be downloaded from the Mitsubishi Electric FA Global Website. <https://www.mitsubishielectric.com/app/fa/download/search.do?kisyu=/inv&mode=manual>

Point 

- e-Manual refers to the Mitsubishi FA electronic book manuals that can be browsed using a dedicated tool.
- e-Manual has the following features:
 - Required information can be cross-searched in multiple manuals.
 - Pages that users often browse can be bookmarked.

Manuals related to the FR-E800 inverter are shown in the following table.

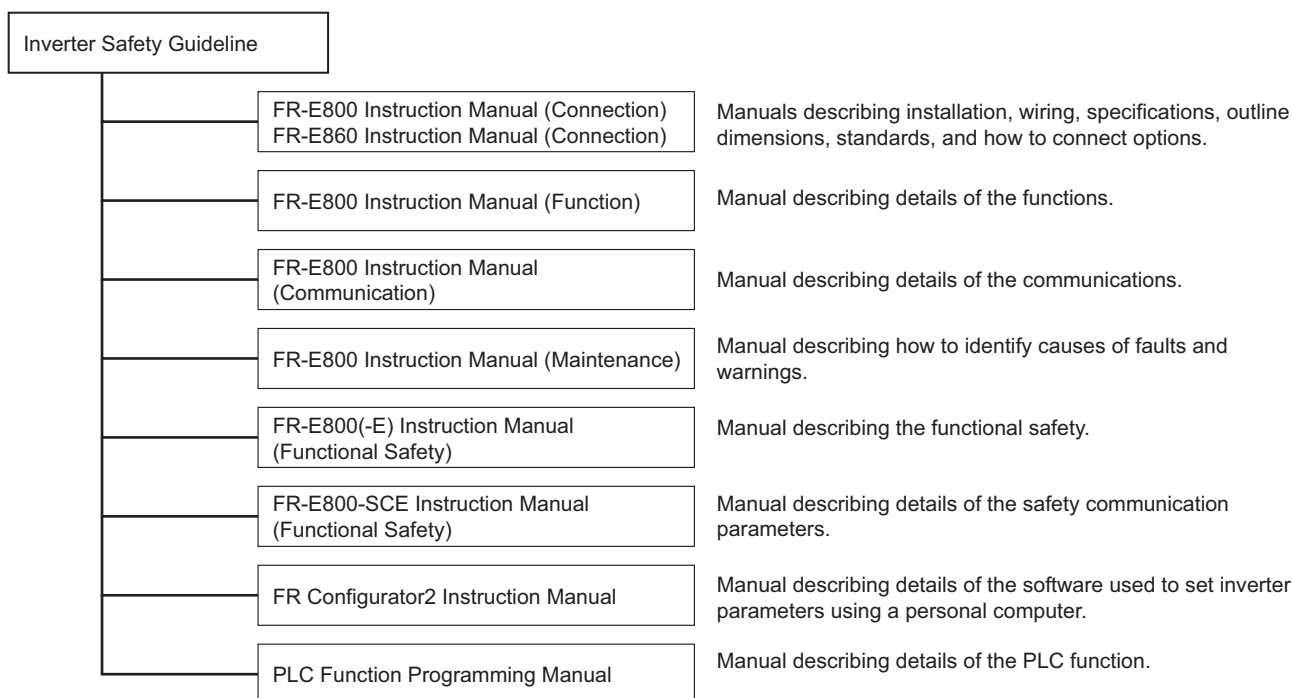

Name	Manual number
FR-E800 Inverter Safety Guideline	IB-0600857ENG
FR-E860 Inverter Safety Guideline	IB-0600862ENG
FR-E800-E Inverter Safety Guideline	IB-0600860ENG
FR-E860-E Inverter Safety Guideline	IB-0600863ENG
FR-E800-SCE Inverter Safety Guideline	IB-0600921ENG
FR-E860-SCE Inverter Safety Guideline	IB-0600924ENG
FR-E806-SCE Inverter Safety Guideline	IB-0600984ENG
FR-E800 Instruction Manual (Connection)	IB-0600865ENG
FR-E860 Instruction Manual (Connection)	IB-0600906ENG
FR-E800 Instruction Manual (Function)	IB-0600868ENG
FR-E800 Instruction Manual (Maintenance)	IB-0600874ENG
FR-E800(-E) Instruction Manual (Functional Safety)	BCN-A23488-000(E)
FR-E800-SCE Instruction Manual (Functional safety)	BCN-A23488-004(E)
FR Configurator2 Instruction Manual	IB-0600516ENG
PLC Function Programming Manual	IB-0600492ENG

CHAPTER 2 Ethernet Communication

- 2.1 Outline12
- 2.2 Wiring.....13
- 2.3 Ethernet cable connection15
- 2.4 Initial setting for Ethernet communication.....18
- 2.5 CC-Link IE TSN19
- 2.6 CC-Link IE Field Network Basic.....59
- 2.7 MODBUS/TCP88
- 2.8 BACnet/IP107
- 2.9 MELSOFT / FA product connection123
- 2.10 SLMP126
- 2.11 EtherNet/IP143
- 2.12 PROFINET171
- 2.13 EtherCAT196
- 2.14 Backup/restore.....220
- 2.15 Inverter-to-inverter link function222
- 2.16 Ethernet communication parameters.....225

2 Ethernet Communication

2.1 Outline

Ethernet communication is available for the Ethernet model, the safety communication model, and the IP67 model.

◆ Precautions for communication

- To maintain the security (confidentiality, integrity, and availability) of the inverter and the system against unauthorized access, DoS^{*1} attacks, computer viruses, and other cyberattacks from external devices via network, take appropriate measures such as firewalls, virtual private networks (VPNs), and antivirus solutions. We shall have no responsibility or liability for any problems involving inverter trouble and system trouble by DoS attacks, unauthorized access, computer viruses, and other cyberattacks.
- Depending on the network environment, the inverter may not operate as intended due to delays or disconnection in communication. Carefully consider what type of environment the inverter will be used in and any safety issues related to its use.

*1 DoS: A denial-of-service (DoS) attack disrupts services by overloading systems or exploiting vulnerabilities, resulting in a denial-of-service (DoS) state.

◆ Ethernet communication specifications

The communication specification varies depending on the specification of the master or the communication protocol.

Item	Description
Category	100BASE-TX/10BASE-T
Data transmission speed	100 Mbps (100BASE-TX) / 10 Mbps (10BASE-T)
Transmission method	Baseband
Maximum segment length	100 m between the hub and the inverter
Number of cascade connection stages	Up to 2 (100BASE-TX) / up to 4 (10BASE-T)
Topology	Line, star, ring, or a combination of line and star ^{*1}
Interface	RJ-45 ^{*2}
Number of interfaces available	2
IP version	IPv4

*1 Ring topology is available only for EtherCAT communication.

*2 Available only for the Ethernet model and the safety communication model. For connectors available for the IP67 model, refer to the Instruction Manual (Connection).

◆ Operation status LEDs

LED name	Description	LED status	Remarks
NS	Communication status	OFF	Duplicate IP address not detected
		Red	Duplicate IP address detected
MS	Inverter status	OFF	Power-OFF / during inverter reset
		Green	Operating properly
		Red	Fault detected
LINK1	Connector for communication (PORT1) status	OFF	Power-OFF/link-down
		Blinking green	Link-up (Data reception in progress)
		Solid green	Link-up
LINK2	Connector for communication (PORT2) status	OFF	Power-OFF/link-down
		Blinking green	Link-up (Data reception in progress)
		Solid green	Link-up
NET	SLMP command request message reception status	OFF	Power-OFF / inverter identification disabled / inverter identification paused
		Blinking green	Inverter identification in progress ^{*1}
		Solid green	Network operation mode

*1 While "1 (initial value)" is set in **Pr.1399 Inverter identification enable/disable selection**, this LED blinks when the MAC/IP address of the inverter match to the MAC/IP address specified by using engineering software such as FR Configurator2.

2.2 Wiring

2.2.1 System configuration example

1. Select the connection method. (Refer to [page 13.](#))
2. Prepare the equipment required for wiring. (Refer to [page 13.](#))
3. Turn OFF the power of the programmable controller and the inverter.
4. Connect the programmable controller (master) and the inverters with Ethernet cables. (Refer to [page 15.](#))

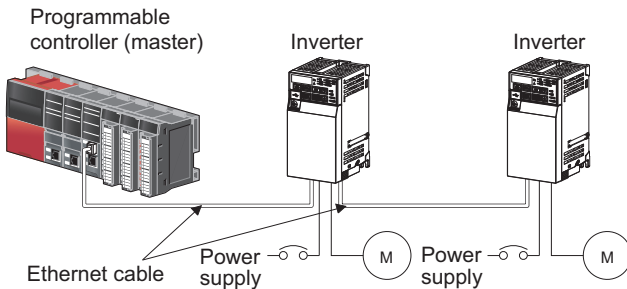

2.2.2 Network configuration

◆ Network topology

The network can be wired into star topology, line topology, and ring topology. A network can consist of a combination of star and line topologies.

Item	Description
Star topology ^{*1}	Units are configured into a star using a switching hub and Ethernet cables. Except for the master, units can be easily added in a star topology. Furthermore, data link continues among normally-operating stations in a star topology.
Line topology	Units are configured into a line using Ethernet cables. A switching hub is not required.
Ring topology ^{*2}	Units are configured into a ring using Ethernet cables. Data link continues with the stations that are operating normally.

*1 A general-purpose switching hub cannot be used for EtherCAT communication. Use an EtherCAT branch slave.

*2 Ring topology is available only for EtherCAT communication. Use an EtherCAT branch slave.

◆ Station number and connection position

Units can be connected in any order regardless of the station number.

◆ Replacing CC-Link IE TSN devices

For star topology, units (except for the master) can be replaced without powering off the whole system.

NOTE

- Refer to the Master Module User's Manual for detailed network configurations.

2.2.3 Network components

◆ Connection cable

Use Ethernet cables compliant with the following standards.

Ethernet cable	Connector	Type
Category 5 or higher straight cable (double shielded / STP)	RJ-45 connector	The following conditioning cables: • IEEE 802.3 (100BASE-TX) • ANSI/TIA/EIA-568-B (Category 5)

- Recommended product (as of April 2023)

Model	Manufacturer
SC-E5EW series ^{*1}	Mitsubishi Electric System & Service Co., Ltd.

^{*1} SC-E5EW cable is for in-enclosure use and indoor use for fixed parts, SC-E5EW-MV cable for indoor use for moving parts, and SC-E5EW-L cable for outdoor use.

NOTE

- Depending on the cable connector shape, the cable may not be connected to the inverter.
- For connection cables used for wiring of the IP67 model, refer to the Instruction Manual (Connection).

◆ Hubs

Use hubs that meet the following conditions. Operation is not guaranteed if the hubs do not meet these conditions.

- Compliance with the IEEE 802.3 (100BASE-TX)
- Support of the auto MDI/MDI-X function
- Support of the auto-negotiation function
- Switching hub (layer 2 switch)^{*1}

^{*1} A repeater hub is not available.

NOTE

- A general-purpose switching hub cannot be used for EtherCAT communication. For star or ring topology, use an EtherCAT branch slave.

2.3 Ethernet cable connection

This section explains Ethernet cable connection and the relevant precautions. For the details of the network configuration and the cables and hubs used for wiring, refer to [page 13](#) onwards.

2.3.1 Wiring method (Ethernet model / safety communication model)

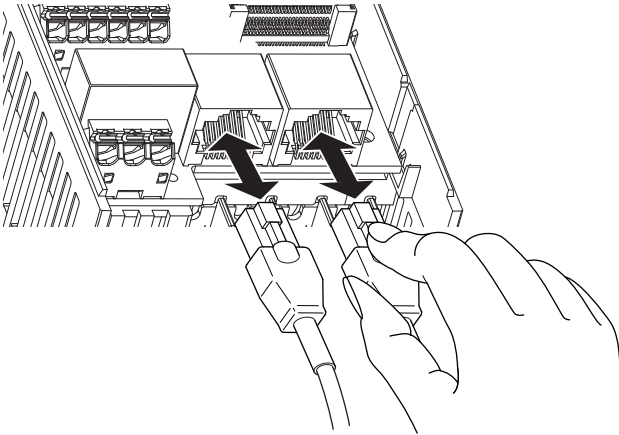

◆ Installation

1. Turn OFF the power of the programmable controller and the inverter.
2. Remove the inverter front cover.
3. Check the orientation of the connectors. Insert the connector part of the Ethernet cable to the communication connector until it clicks.

◆ Removal

1. Turn OFF the power of the programmable controller and the inverter.
2. Remove the inverter front cover.
3. Hold down the latch on the Ethernet cable connector, and pull out the cable while holding the latch.

NOTE

- For PROFINET communication, refer to [page 171](#).
- For EtherCAT communication, refer to [page 196](#).
- There is no need to distinguish between PORT1 and PORT2 on the inverter (except for PROFINET and EtherCAT).
- When only one connector is used in star topology, either PORT1 or PORT2 is applicable.
- When using two connectors for line topology, an Ethernet cable can be connected to the connectors in any combination. For example, the cable can be connected across two of PORT1 or across PORT1 and PORT2.

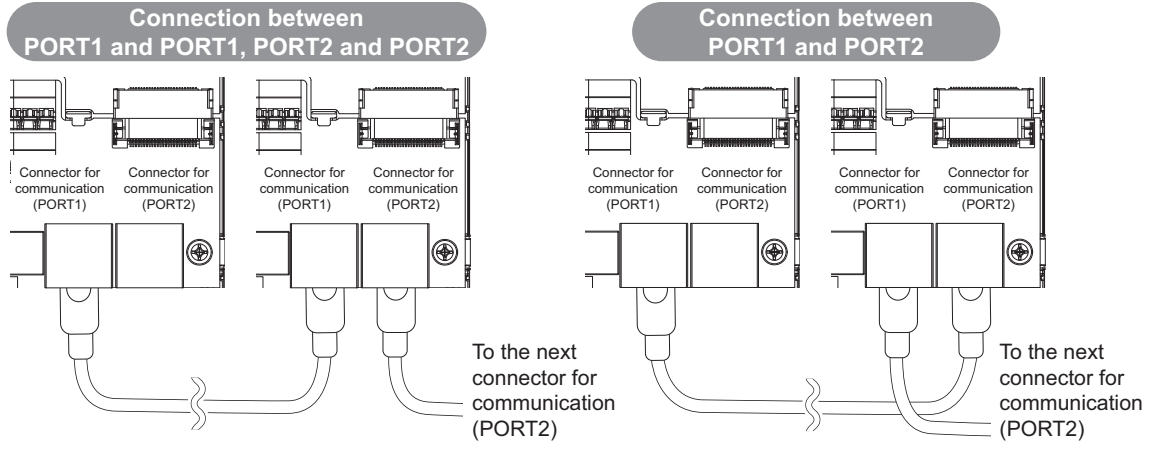

2.3.2 Wiring method (IP67 model)

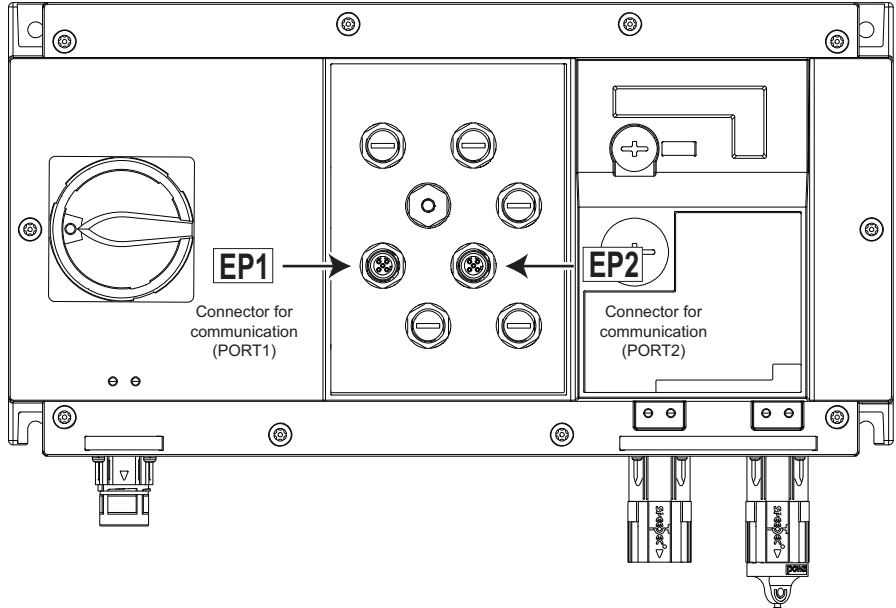

◆ Installation

1. Turn OFF the power of the programmable controller and the inverter.
2. Remove the resin caps of the communication connectors.
3. Check the orientation of the connectors. Insert the connector part of the Ethernet cable to the communication connector.

◆ Removal

1. Turn OFF the power of the programmable controller and the inverter.
2. Pull out the Ethernet cable.
3. Reinstall the resin caps of the communication connectors. (Tightening torque: 0.7 N·m)

NOTE

- For PROFINET communication, refer to [page 171](#).
- There is no need to distinguish between PORT1 and PORT2 on the inverter (except for PROFINET).
 - When only one connector is used in star topology, either PORT 1 or PORT 2 is applicable.
 - When using two connectors for line topology, an Ethernet cable can be connected to the connectors in any combination. For example, the cable can be connected across two of PORT1 or across PORT1 and PORT2.

2.3.3 Wiring precautions

This section explains Ethernet cable connection and the relevant precautions.

◆ Handling of the Ethernet cable

- Do not touch the conductors of the cable or the connector on the inverter. Keep the conductors free of dust or dirt. If oil from your hand, dirt or dust is attached to the core, it can increase transmission loss, arising a problem in data link.
- Check the following:
 - Is any Ethernet cable disconnected?
 - Is any of the Ethernet cables shorted?
 - Are the connectors securely connected?
- Do not use Ethernet cables with broken latches. Doing so may cause the cable to unplug or malfunction.
- The maximum station-to-station distance is 100 m. However, the distance may be shorter depending on the operating environment of the cable. For details of the cable, contact your cable manufacturer.

◆ Connecting and disconnecting of the Ethernet cable

Hold the connector part when connecting and disconnecting the Ethernet cable. Pulling a cable connected to the inverter may damage the inverter or cable, or result in malfunction due to poor contact.

◆ Network configuration

Check the network configuration before wiring, and perform correct wiring. For example, using ring topology for inverters other than the FR-E800-(SC)EPC may cause system failure.

2.4 Initial setting for Ethernet communication

Use the following parameters to perform required settings for Ethernet communication between the inverter and other devices. To make communication between other devices and the inverter, perform the initial settings of the inverter parameters to match the communication specifications of the devices. Data communication cannot be made if the initial settings are not configured or if there is any setting error.

Pr.	Name	Initial value	Setting range	Description
1434 N600 ^{*1*2}	IP address 1 (Ethernet)	192	0 to 255	Enter the IP address of the inverter to be connected to Ethernet.
1435 N601 ^{*1*2}	IP address 2 (Ethernet)	168		
1436 N602 ^{*1*2}	IP address 3 (Ethernet)	50		
1437 N603 ^{*1*2}	IP address 4 (Ethernet)	1		

*1 The setting is applied after an inverter reset or next power-ON.

*2 The setting is not available for the FR-E800-(SC)EPC.

◆ IP address (Pr.1434 to Pr.1437)

Enter the IP address of the inverter to be connected to Ethernet in **Pr.1434 to Pr.1437**. (Enter the IP address assigned by the network administrator.)

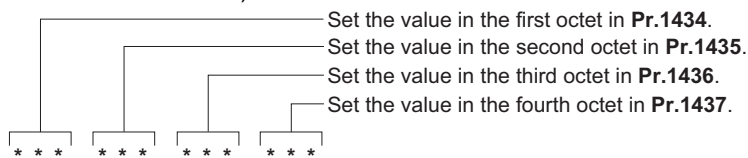

2.5 CC-Link IE TSN

2.5.1 Outline

CC-Link IE TSN

CC-Link IE TSN is available for the FR-E800-(SC)EPA, FR-E806-SCEPA, FR-E800-(SC)EPB, and FR-E806-SCEPB. Data can be transmitted to IT systems while performing real-time cyclic communication control.

Some functions are not supported depending on the date of manufacture of the inverter. For details of specification changes, refer to [page 290](#).

◆ CC-Link IE TSN authentication classes

- Devices (nodes) and switches on the CC-Link IE TSN network are classified into different authentication classes according to their functionality and performance. There are two authentication classes: A and B. For details of the authentication class of each product, check the information on the web site of the CC-Link Partner Association, or refer to catalogs and manuals of each product. Different functions and system configurations are available depending on the authentication class of the devices to be used. For example, use authentication class B devices to construct a high-speed motion control system. For details of system construction such as mixing devices of both class A and class B, check the manuals of the applicable master device.

◆ Communication specifications

The communication specification varies depending on the specification of the master.

Item	Description	
Communication speed	100 Mbps (10 Mbps is not supported.)	
Authentication class	A (Compatible with protocol versions 2.0 ^{*1} and 1.0)	
Communication mode	Unicast	
Cycle time ^{*2}	5000 to 6400000 μs	
Communication method	Protocol version 2.0: Time-managed polling method ^{*1} Protocol version 1.0: Time sharing method	
Time synchronization	Protocol version 2.0: Unavailable Protocol version 1.0: Available (conforming to IEEE 1588v2)	
Maximum number of connected units	121 units (sum of master and remote stations)	
Maximum number of branches	No upper limit on the same Ethernet network	
Connection cable	Ethernet cable (IEEE 802.3 100BASE-TX compliant cable and ANSI/TIA/EIA-568-B (Category 5) compliant shielded 4-pair branched cable)	
Topology	Line, star, or a combination of line and star	
Node type	Remote station	
Maximum cyclic size (of one node)	RX	32 bits
	RY	32 bits
	RWr	32 words
	RWw	32 words

*1 Supported by the inverter whose firmware version is 9 or later.

*2 Consider the scaling factor in the multiple period setting to change the basic period setting on the engineering software (GX Works3).

NOTE

- To use the CC-Link IE TSN, do not install the FR-A8NC E kit to the inverter. (Installing the FR-A8NC E kit disables CC-Link IE TSN.)

◆ Operation status LEDs

LED name	Description	LED status	Remarks
NS	Communication status	OFF	Power-OFF
		Blinking green	Data transmission not performed
		Solid green	Data transmission in progress
		Blinking red	Communication interrupted
		Solid red	Duplicate IP address detected
MS	Inverter status	OFF	Power-OFF / during inverter reset
		Green	Operating properly
		Red	Fault detected
LINK1	Connector for communication (PORT1) status	OFF	Power-OFF/link-down
		Blinking green	Link-up (Data reception in progress)
		Solid green	Link-up
LINK2	Connector for communication (PORT2) status	OFF	Power-OFF/link-down
		Blinking green	Link-up (Data reception in progress)
		Solid green	Link-up

◆ Combination with the master station

■ When all remote stations are authentication class A products

Master station	Master station communication speed	Network configuration
<ul style="list-style-type: none"> MELSEC iQ-R series master/local module RJ71GN11-T2, RJ71GN11-EIP MELSEC iQ-F series master/local module FX5-CCLGN-MS Master station that supports both 1 Gbps and 100 Mbps communication speeds 	1 Gbps	<ul style="list-style-type: none"> Line topology / star topology / combination of line topology and star topology^{*1} Connection sequence: Master station → Remote station (communication speed: 1 Gbps) → General-purpose switching hub^{*2} → Remote station (communication speed: 100 Mbps)
	100 Mbps	<ul style="list-style-type: none"> Line topology / star topology / combination of line topology and star topology Remote station (communication speed: 100 Mbps)
<ul style="list-style-type: none"> MELSEC iQ-R series Motion module RD78G[]/GH[] MELSEC iQ-F series Motion module FX5-[]SSC-G 	1 Gbps	<ul style="list-style-type: none"> Line topology / star topology / combination of line topology and star topology^{*1} Connection sequence: Master station → Remote station (communication speed: 1 Gbps) → General-purpose switching hub^{*2} → Remote station (communication speed: 100 Mbps)
	100 Mbps	<ul style="list-style-type: none"> Line topology / star topology / combination of line topology and star topology Remote station (communication speed: 100 Mbps)

■ When both authentication class B and class A products are used as remote stations

Master station	Master station communication speed	Network configuration
<ul style="list-style-type: none"> MELSEC iQ-R series master/local module RJ71GN11-T2, RJ71GN11-EIP MELSEC iQ-F series master/local module FX5-CCLGN-MS Master station that supports both 1 Gbps and 100 Mbps communication speeds 	1 Gbps	<ul style="list-style-type: none"> Line topology / star topology / combination of line topology and star topology^{*1} Connection sequence: Master station → Remote station (authentication class B, communication speed: 1 Gbps) → General-purpose switching hub^{*2} → Remote station (authentication class A, communication speed: 100 Mbps)
	100 Mbps	<ul style="list-style-type: none"> Line topology / star topology / combination of line topology and star topology Connection sequence: Master station → Remote station (authentication class B) → Remote station (authentication class A)
<ul style="list-style-type: none"> MELSEC iQ-R series Motion module RD78G[]/GH[] MELSEC iQ-F series Motion module FX5-[]SSC-G 	1 Gbps	<ul style="list-style-type: none"> Line topology / star topology / combination of line topology and star topology^{*1} Connection sequence: Master station → Remote station (authentication class B, communication speed: 1 Gbps) → General-purpose switching hub^{*2} → Remote station (authentication class A, communication speed: 100 Mbps)
	100 Mbps	<ul style="list-style-type: none"> Line topology / star topology / combination of line topology and star topology Connection sequence: Master station → Remote station (authentication class B) → Remote station (authentication class A)

- *1 Line topology is available for the products whose communication speed settings are the same.
- *2 Use the product that supports 1 Gbps / 100 Mbps.

NOTE

- When all remote stations are authentication class A products, up to 120 units can be connected.

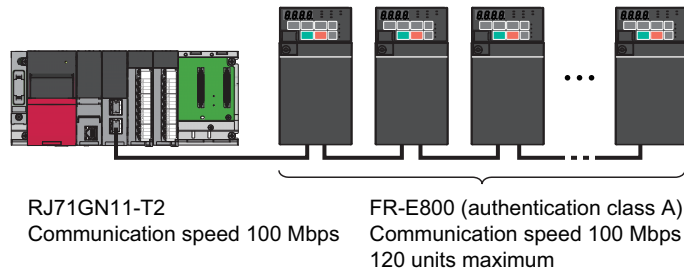

- When both authentication class B and class A products are used, the maximum number of connectable remote stations differs depending on the protocol version. For calculation of the cyclic data size, refer to the Master Module User's Manual. Class A units should be connected starting from the remotest class B unit.

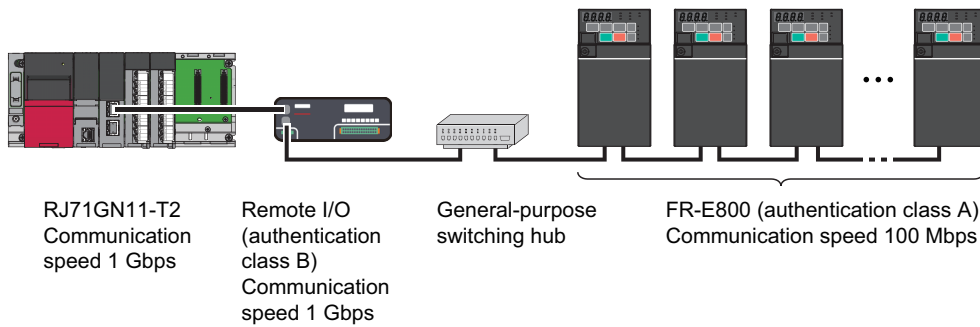

Protocol version	Maximum number of connected units
2.0	120 units (total of the authentication class A and class B products)
1.0	10 units when all authentication class A products are FR-E800 inverters (The total size of cyclic data of all class A units must not exceed 2k bytes per port on the master station.)

- When the master station has more than one port, use separate ports for both authentication classes to enable connection of up to 120 remote station units. For example, use port 1 for authentication class B products only, and port 2 for class A products only.

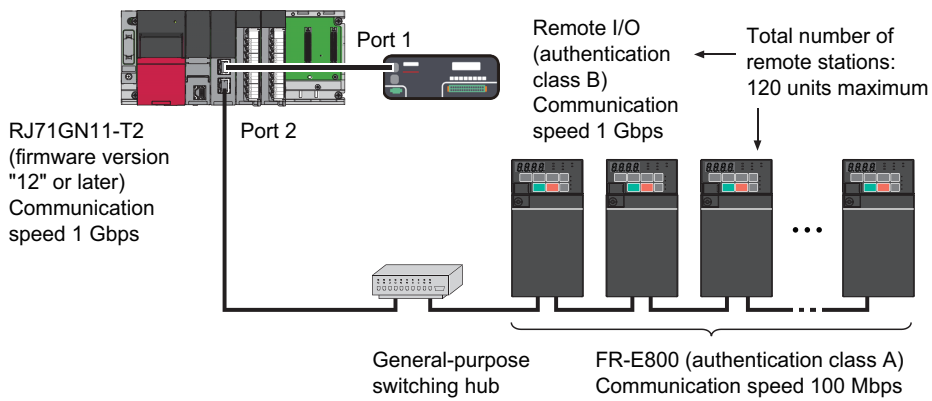

Compatible firmware version of the master station

Model	Compatible with protocol version 2.0	Compatible with protocol version 1.0
RJ71GN11-T2	15 or later	12 or later
RJ71GN11-EIP	01 or later	
FX5-CCLGN-MS	1.010 or later	1.001 or later
RD78G[]/GH[]	20 or later	
FX5-[]SSC-G	1.002 or later	

Compatible firmware version of the inverter

SERIAL	Version	Description
□□ 225 ○○○○○○ or later	9 or later	Compatible with protocol version 2.0
□□ 211 ○○○○○○ or later	3 or later	Compatible with protocol version 1.0. Compatible with protocol version 2.0 by updating the firmware to version 9 or later.
□□ 20Z ○○○○○○ or earlier	—	Compatible with protocol version 1.0. Protocol version of the master station is automatically set or set to 1.0.

Compatible version of the engineering software

Name	Version	Description
GX Works3	1.080J or later	Compatible with protocol version 2.0

Related manuals

For details of network configurations, refer to the Master Module User's Manual.

Name	Manual number
MELSEC iQ-R CC-Link IE TSN User's Manual (Startup)	SH-082127ENG
MELSEC iQ-R CC-Link IE TSN User's Manual (Application)	SH-082129ENG
MELSEC iQ-F FX5 User's Manual (CC-Link IE TSN)	SH-082215ENG
MELSEC iQ-R Motion Module User's Manual (Startup)	IB-0300406ENG
MELSEC iQ-R Motion Module User's Manual (Application)	IB-0300411ENG

2.5.2 CC-Link IE TSN configuration

Procedure

The following shows the procedure to connect the inverter with a Mitsubishi Electric master device.

Before communication

1. Connect each unit with an Ethernet cable. (Refer to [page 15](#).)
2. Enter the IP address (**Pr.1434 to Pr.1437**). (Refer to [page 18](#).)
3. Set "45238" (CC-Link IE TSN) in any of **Pr.1427 to Pr.1430 Ethernet function selection 1 to 4**. (Refer to [page 28](#).)
In the initial status, **Pr.1429** = "45238" (CC-Link IE TSN) and setting is not required.
4. Set the protocol version (**Pr.1210**). (Refer to [page 28](#).)
5. Reset the inverter, or turn OFF and then ON the power.

Registering a profile

1. Start the engineering software (GX Works3).
2. On the menu bar, select [Tool] > [Profile Management] > [Register...].
3. Select a CSP+ file to be registered on the "Register Profile" screen, and click the [Register] button.

NOTE

- A profile is a compressed file (such as *.zip, *.ipar, and *.cspp). Register a profile without decompressing the file.
- Profile registration is not required for the next time onwards.

■ Creating a project file

1. For information on creating and opening a project, go to [Help] > [GX Works3 Help].

■ Detecting an Inverter

Detection is not possible when the data link is not established with the master module. For details, refer to the Master Module User's Manual.

1. In the "Navigation" window, select [Parameter] > [Module Information] then select the module name.

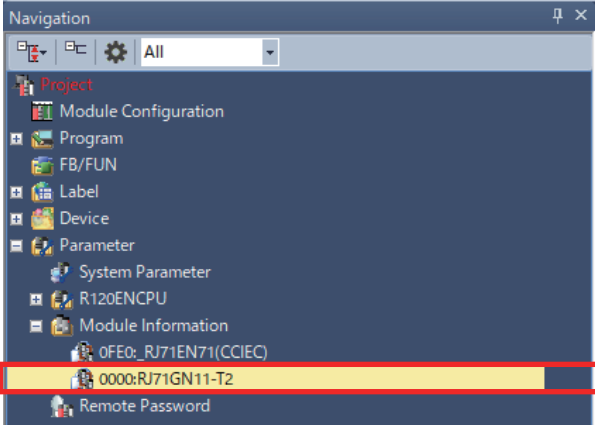

2. Select [Basic Settings] in the "Setting Item List" window.

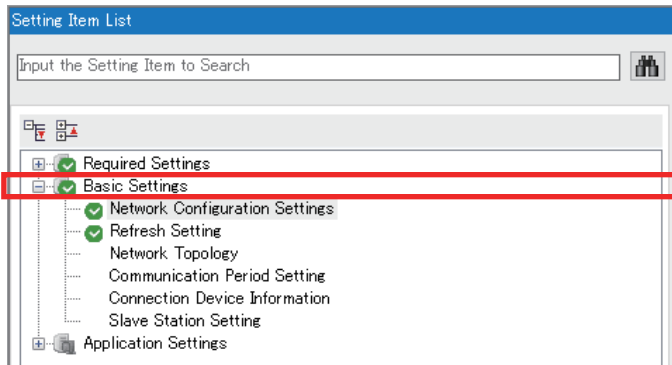

3. In the "Setting Item" window, go to [Network Configuration Settings] then click next to the [Detailed Setting] field.

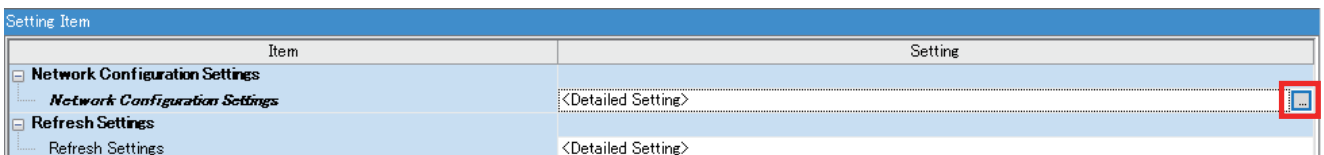

4. Click [Connected/Disconnected Module Detection] in the "CC-Link IE TSN configuration" window.

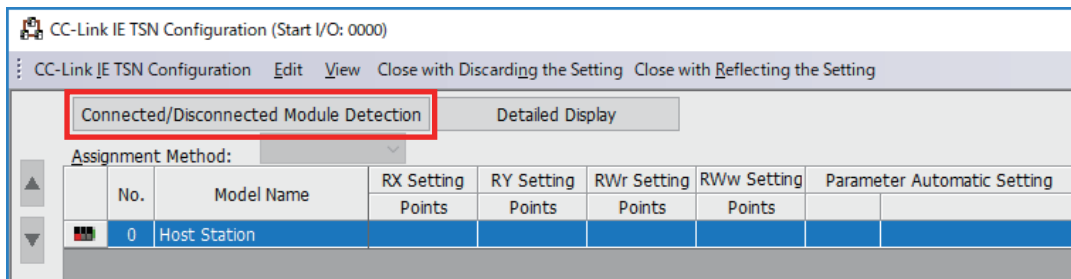

5. Read the cautions in the "Connected/Disconnected Module Detection" window and click [Execute].

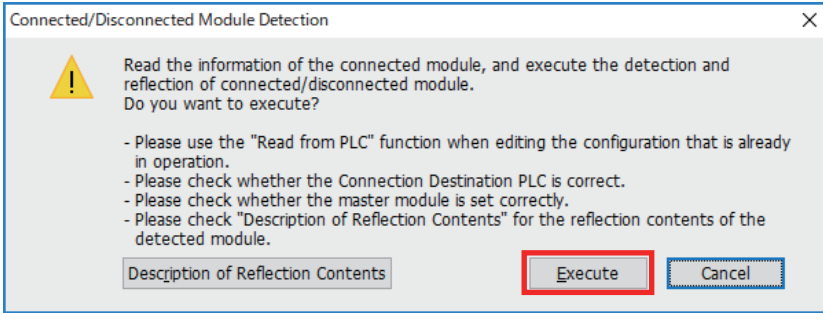

6. The inverter model will appear on the screen when it is detected. (FR-E800-E inverters are displayed in the following example.) Click [Close with Reflecting the Setting] to close the window.

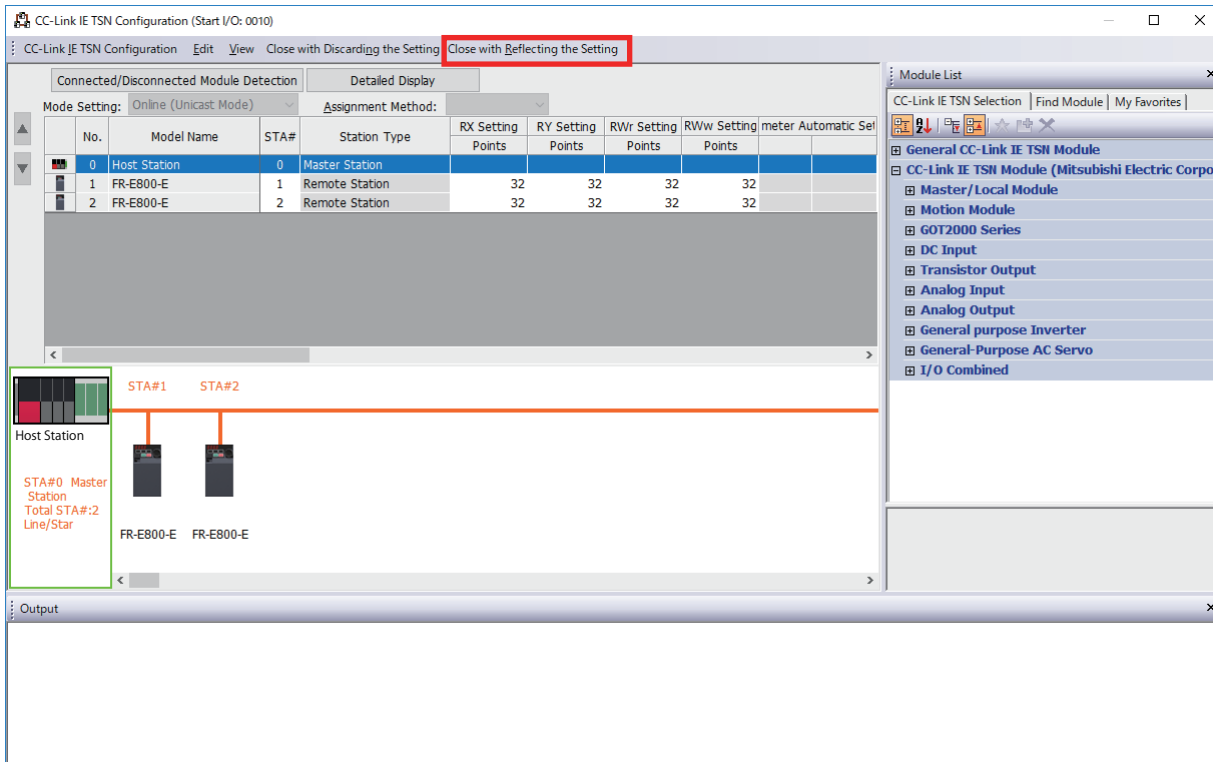

■ System setting window (communication speed setting of the master: 1 Gbps)

1. Select [Basic Settings] in the "Setting Item List" window.

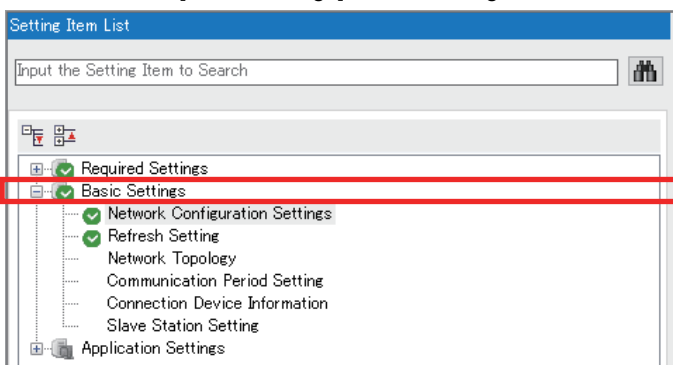

2. In the "Setting Item" window, go to [Network Configuration Settings] then click [...] next to the [Detailed Setting] field.

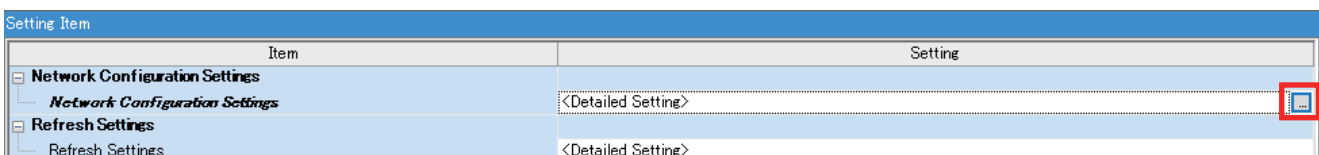

3. In the "CC-Link IE TSN Configuration" window, set "Low-Speed" for [Communication Period Setting].

Default Gateway	Reserved/Error Invalid Station	Network Synchronous Communication	Communication Period Setting
	No Setting	Asynchronous	Low-Speed

4. Set "1000.00 μs" (initial value) for [Communication Period Interval Setting (Do not Set it in Units of 1us)].

- When RJ71GN11-T2 is the master

Set "20.00 μs" (initial value) for [System Reservation Time].

Consider the scaling factor in [Multiple Period Setting] - [Low-Speed] to change the settings for [Basic Period Setting]. Refer to the following examples.

[Communication Period Interval Setting] = "5000.00 μs" / "16 (initial value)" (minimum value)

[System Reservation Time] = "200.00 μs" / "16 (initial value)" (minimum value)

Communication Period Setting	
Basic Period Setting	
Setting in Units of 1us	Not Set
Communication Period Interval Setting (Do not Set it in Units of 1us)	1000.00 us
Communication Period Interval Setting (Set it in Units of 1us)	1000.00 us
System Reservation Time	20.00 us
Cyclic Transmission Time	500.00 us
Transient Transmission Time	480.00 us
Multiple Period Setting	
Normal-Speed	x4
Low-Speed	x16

- When FX5-CCLGN-MS is the master

Set "500.00 μs" (initial value) for [Cyclic Transmission Time].

Consider the scaling factor in [Multiple Period Setting] - [Low-Speed] to change the settings for [Basic Period Setting]. Refer to the following examples.

[Communication Period Interval Setting] = "5000.00 μs" / "16 (fixed)" (minimum value)

Communication Period Setting	
Basic Period Setting	
Setting in Units of 1us	Not Set
Communication Period Interval Setting (Do not Set it in Units of 1us)	1000.00 us
Communication Period Interval Setting (Set it in Units of 1us)	1000.00 us
System Reservation Time	20.00 us
Cyclic Transmission Time	500.00 us
Transient Transmission Time	480.00 us

5. Set "Mixture of Authentication Class B/A or Authentication Class A Only" for [Authentication Class Setting].

Connection Device Information	
Authentication Class Setting	Mixture of Authentication Class B/A or Authentication Class A Only

6. Select [Application Settings] in the "Setting Item List" window.

Setting Item List	
Input the Setting Item to Search	
<ul style="list-style-type: none"> Required Settings Basic Settings <ul style="list-style-type: none"> Network Configuration Settings Refresh Setting Network Topology Communication Period Setting Connection Device Information Slave Station Setting Application Settings 	

7. Set "1 Gbps" for [Communication Speed].

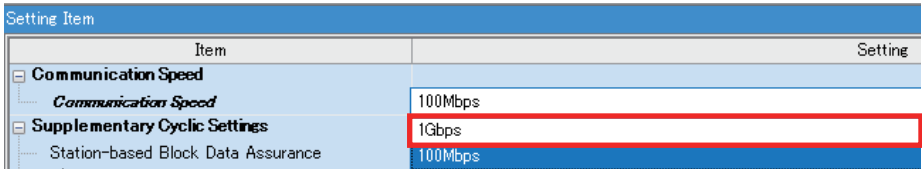

■ System setting window (communication speed setting of the master: 100 Mbps)

1. Select [Basic Settings] in the "Setting Item List" window.

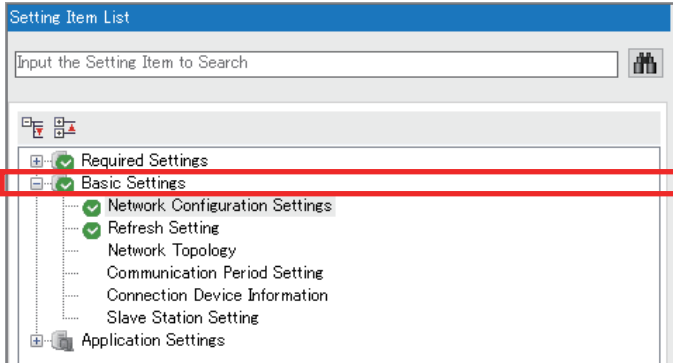

2. In the "Setting Item" window, go to [Network Configuration Settings] then click [...] next to the [Detailed Setting] field.

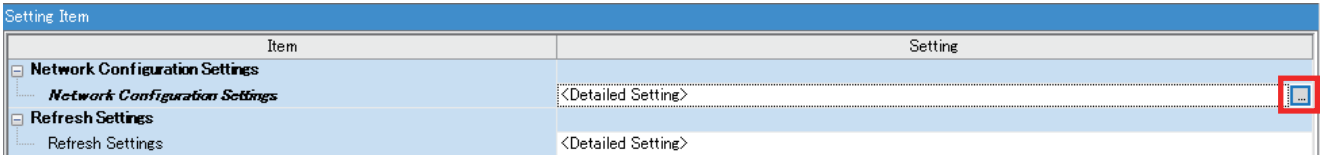

3. In the "CC-Link IE TSN Configuration" window, set "Basic Period" for [Communication Period Setting]. When [Multiple Period Setting] is used, set "Normal-Speed" or "Low-Speed".

Default Gateway	Reserved/Error Invalid Station	Network Synchronous Communication	Communication Period Setting
No Setting	Asynchronous	Basic Period	

4. Set "5000.00 μs" or larger value for [Communication Period Interval Setting (Do not Set it in Units of 1us)]. Set "200.00 μs" for [System Reservation Time]. Set "1000.00 μs" for [Cyclic Transmission Time].

Consider the scaling factor in [Multiple Period Setting] - [Normal-Speed] or [Low-Speed] to change the settings for [Basic Period Setting]. Refer to the following examples.

[Communication Period Interval Setting] = "5000.00 μs" / "16 (initial value for [Low-Speed])" (minimum value)

[System Reservation Time] = "200.00 μs" / "16 (initial value for [Low-Speed])" (minimum value)

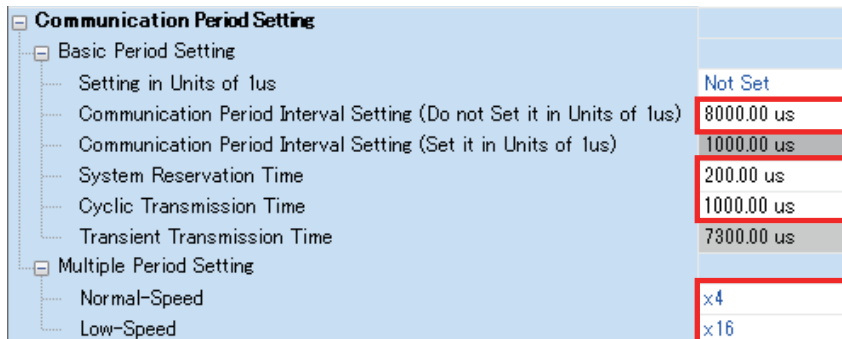

5. Set "Mixture of Authentication Class B/A or Authentication Class A Only" for [Authentication Class Setting].



6. Select [Application Settings] in the "Setting Item List" window.

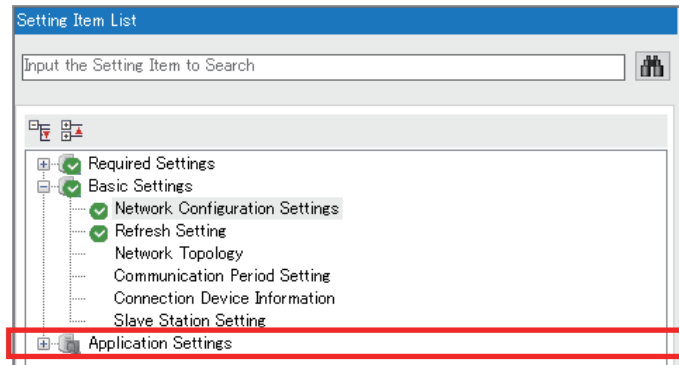

7. Set "100 Mbps" for [Communication Speed].

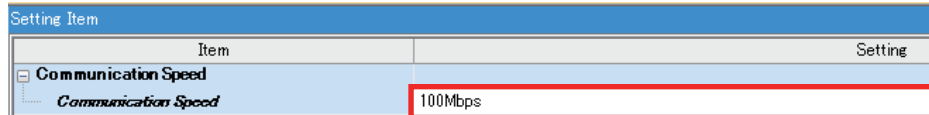

■ Checking communication

The following table shows the status of the LEDs when communication is established between the programmable controller and the inverter. Check the "CC-Link IE TSN/CC-Link IE Field Diagnostics" window to confirm that the communication is established between them.

NS	MS	LINK1	LINK2
Solid green	Solid green	Blinking green ^{*1}	

*1 The LED on either LINK1 or LINK2 will blink depending on the port (port 1 or 2) the Ethernet cable is connected to.

NOTE

- If the inverter cannot be detected, on the menu bar select [Diagnostics (D)] → [CC Link IE TSN / CC Link IE Field Diagnostics]. The "CC Link IE TSN / CC Link IE Field Diagnostics" window will be displayed. Broken or disconnected wires can be detected.
- The network configuration diagram is displayed in star topology even if the devices are connected in line topology.

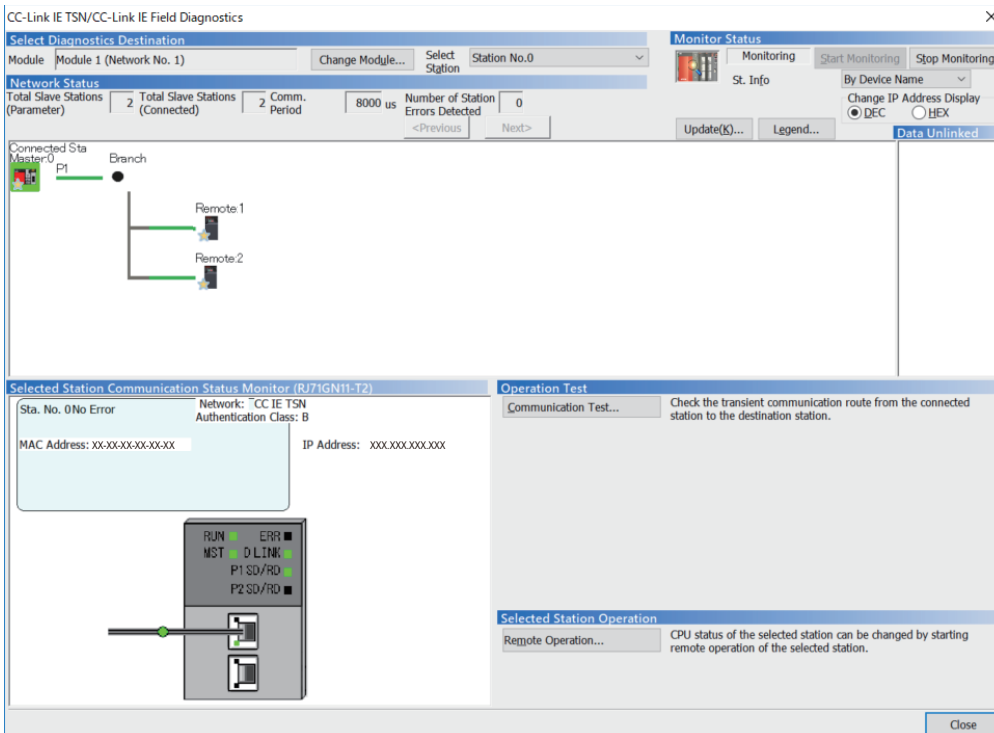

2.5.3 Initial setting for CC-Link IE TSN

Use the following parameters to perform required settings for Ethernet communication between the inverter and other devices. To make communication between other devices and the inverter, perform the initial settings of the inverter parameters to match the communication specifications of the devices. Data communication cannot be made if the initial settings are not configured or if there is any setting error.

Pr.	Name	Initial value	Setting range	Description
1210 N120 ^{*1}	CC-Link IE TSN protocol version selection	0	0, 9999	Set the CC-Link IE TSN protocol version.
1427 N630 ^{*1}	Ethernet function selection 1	5001	502, 5000 to 5002, 5006 to 5008, 5010 to 5013, 9999, 34962 ^{*3} , 44818 ^{*2} , 45237, 45238, 47808 ^{*2} , 61450	Set the application, protocol, etc.
1428 N631 ^{*1}	Ethernet function selection 2	45237		
1429 N632 ^{*1}	Ethernet function selection 3	45238		
1430 N633 ^{*1}	Ethernet function selection 4	9999		

*1 The setting is applied after an inverter reset or next power-ON.

*2 The setting is available for the FR-E800-(SC)EPA and FR-E806-SCEPA.

*3 The setting is available for the FR-E800-(SC)EPB and FR-E806-SCEPB.

◆ Ethernet function selection (Pr.1427 to Pr.1430)

To select CC-Link IE TSN for the application, set "45238" (CC-Link IE TSN) in any of **Pr.1427 to Pr.1430 Ethernet function selection 1 to 4**. In the initial status, **Pr.1429** = "45238" (CC-Link IE TSN) and setting is not required.

NOTE

- Change the setting if selected communication protocols cannot be used together. (Refer to [page 7](#) and [page 226](#).)

◆ CC-Link IE TSN protocol version selection (Pr.1210)

- Set the CC-Link IE TSN protocol version.

Pr.1210 setting	Description
0 (initial value)	Protocol version 2.0
9999	Protocol version 1.0

NOTE

- When the setting is changed after the communication is established, also reset the master station.
- When the protocol version 2.0 is used, the master station also must be compatible with the protocol version 2.0.

2.5.4 Parameters related to CC-Link IE TSN

The following parameters are used for CC-Link IE TSN communication. Set the parameters as required.

Pr.	Name	Initial value	Setting range	Description
541 N100	Frequency command sign selection	0	0 1	Signed frequency command value Unsigned frequency command value
544 N103 ^{*1}	CC-Link extended setting	0	0, 1, 12, 14, 18, 38, 100, 112, 114, 118, 138	Use this parameter to extend the function of the remote registers for the CC-Link IE TSN.
1426 N641 ^{*1}	Link speed and duplex mode selection	0	0 to 4	Set the communication speed and the communication mode (full-duplex/half-duplex).

Pr.	Name	Initial value	Setting range	Description
1442 N660 ^{*1}	IP filter address 1 (Ethernet)	0	0 to 255	Set the range of connectable IP addresses for the network devices. (When Pr.1442 to Pr.1445 = "0 (initial value)", the function is invalid.)
1443 N661 ^{*1}	IP filter address 2 (Ethernet)	0		
1444 N662 ^{*1}	IP filter address 3 (Ethernet)	0		
1445 N663 ^{*1}	IP filter address 4 (Ethernet)	0		
1446 N664 ^{*1}	IP filter address 2 range specification (Ethernet)	9999	0 to 255, 9999	
1447 N665 ^{*1}	IP filter address 3 range specification (Ethernet)	9999		
1448 N666 ^{*1}	IP filter address 4 range specification (Ethernet)	9999		
1320 to 1329 N810 to N819 ^{*1}	User Defined Cyclic Communication Input 1 to 10 Mapping	9999	5 ^{*2} , 100 ^{*2} , 12288 to 13787, 20488, 20489, 24672, 24689, 24698, 24703, 24705, 24707, 24708, 24719, 24721, 24728 to 24730	Set the index number for inverter parameters, inverter control parameters, and CiA402 drive profile. Functions can be assigned to remote registers RWwn+4 to RWwn+17 when Pr.544 = "38".
			9999	Function disabled
1330 to 1343 N850 to N863 ^{*1}	User Defined Cyclic Communication Output 1 to 14 Mapping	9999	6 ^{*2} , 101 ^{*2} , 12288 to 13787, 16384 to 16483, 20488, 20489, 20981 to 20990, 20992 ^{*3} , 24639, 24643, 24644, 24673 to 24676, 24692, 24695, 24820, 24826, 24828, 25858	Set the index number for inverter parameters, monitor data, inverter control parameters, and CiA402 drive profile. Functions can be assigned to remote registers RWm+4 to RWm+1F when Pr.544 = "38".
			9999	Function disabled
1389 ^{*1}	User Defined Cyclic Communication Input Sub 1 and 2 Mapping	0	0 to 2, 256 to 258, 512 to 514	Pr.1389 (lower 8 bits): Subindex to which the index number is specified using Pr.1320 Pr.1389 (upper 8 bits): Subindex to which the index number is specified using Pr.1321
1390 ^{*1}	User Defined Cyclic Communication Input Sub 3 and 4 Mapping	0	0 to 2, 256 to 258, 512 to 514	Pr.1390 (lower 8 bits): Subindex to which the index number is specified using Pr.1322 Pr.1390 (upper 8 bits): Subindex to which the index number is specified using Pr.1323
1391 ^{*1}	User Defined Cyclic Communication Input Sub 5 and 6 Mapping	0	0 to 2, 256 to 258, 512 to 514	Pr.1391 (lower 8 bits): Subindex to which the index number is specified using Pr.1324 Pr.1391 (upper 8 bits): Subindex to which the index number is specified using Pr.1325
1392 ^{*1}	User Defined Cyclic Communication Input Sub 7 and 8 Mapping	0	0 to 2, 256 to 258, 512 to 514	Pr.1392 (lower 8 bits): Subindex to which the index number is specified using Pr.1326 Pr.1392 (upper 8 bits): Subindex to which the index number is specified using Pr.1327
1393 ^{*1}	User Defined Cyclic Communication Input Sub 9 and 10 Mapping	0	0 to 2, 256 to 258, 512 to 514	Pr.1393 (lower 8 bits): Subindex to which the index number is specified using Pr.1328 Pr.1393 (upper 8 bits): Subindex to which the index number is specified using Pr.1329
N830 to N839 ^{*1}	User Defined Cyclic Communication Input Sub 1 to 10 Mapping	0	0 to 2	Subindices to which the index numbers are specified using Pr.1320 to Pr.1329
1394 ^{*1}	User Defined Cyclic Communication Output Sub 1 and 2 Mapping	0	0 to 2, 256 to 258, 512 to 514	Pr.1394 (lower 8 bits): Subindex to which the index number is specified using Pr.1330 Pr.1394 (upper 8 bits): Subindex to which the index number is specified using Pr.1331

Pr.	Name	Initial value	Setting range	Description
1395*1	User Defined Cyclic Communication Output Sub 3 and 4 Mapping	0	0 to 2, 256 to 258, 512 to 514	Pr.1395 (lower 8 bits): Subindex to which the index number is specified using Pr.1332 Pr.1395 (upper 8 bits): Subindex to which the index number is specified using Pr.1333
1396*1	User Defined Cyclic Communication Output Sub 5 and 6 Mapping	0	0 to 2, 256 to 258, 512 to 514	Pr.1396 (lower 8 bits): Subindex to which the index number is specified using Pr.1334 Pr.1396 (upper 8 bits): Subindex to which the index number is specified using Pr.1335
1397*1	User Defined Cyclic Communication Output Sub 7 and 8 Mapping	0	0 to 2, 256 to 258, 512 to 514	Pr.1397 (lower 8 bits): Subindex to which the index number is specified using Pr.1336 Pr.1397 (upper 8 bits): Subindex to which the index number is specified using Pr.1337
1398*1	User Defined Cyclic Communication Output Sub 9 and 10 Mapping	0	0 to 2, 256 to 258, 512 to 514	Pr.1398 (lower 8 bits): Subindex to which the index number is specified using Pr.1338 Pr.1398 (upper 8 bits): Subindex to which the index number is specified using Pr.1339
N870 to N879*1	User Defined Cyclic Communication Output Sub 1 to 10 Mapping	0	0 to 2	Subindices to which the index numbers are specified using Pr.1330 to Pr.1339
804 D400	Torque command source selection	0	0, 1, 3 to 6	In the torque control mode, the torque command source can be selected.
810 H700	Torque limit input method selection	0	0 to 2	The torque limit input method can be selected.

*1 The setting is applied after an inverter reset or next power-ON.

*2 The setting is available for the FR-E800-(SC)EPB and FR-E806-SCEPB, but the function is disabled.

*3 Available for the Ethernet model only.

◆ Precautions for CC-Link IE TSN communication

- For CC-Link IE TSN, do not change initial values of **Pr.1449 to Pr.1454** used to specify the Ethernet IP address range for command source selection as the IP address is not used. Setting a value other than the initial value in any of the above parameters may cause an Ethernet communication fault (E.EHR). If the fault occurs, reset the setting of the relevant parameter to the initial value, or set "9999" in **Pr.1432 Ethernet communication check time interval**.

◆ CC-Link extended setting (Pr.544)

- Use this parameter to select the function of the remote registers for the CC-Link IE TSN.

Pr.544 setting	Description
0 (initial value), 1, 12, 14, 18	Compatible with the octuple setting of CC-Link Ver.2
38	Compatible with the octuple setting of CC-Link Ver.2, user defined cyclic communication data selected
100, 112, 114, 118	Compatible with the octuple setting of CC-Link Ver.2
138	Compatible with the octuple setting of CC-Link Ver.2, user defined cyclic communication data selected

*1 Refer to the PLC Function Programming Manual.

◆ Frequency command with sign (Pr.541)

- The start command (forward/reverse rotation) can be inverted by adding a plus or minus sign to the value of the frequency command sent through the CC-Link IE TSN.
- The **Pr.541 Frequency command sign selection** setting is applied to the frequency command from RWw1. (Refer to [page 37](#).)

Rotations per minute (machine speed) setting using Pr.37 and Pr.53	Pr.541 setting	Sign	Setting range	Actual frequency command
Disabled	0	Without	0 to 59000	0 to 590.00 Hz
	1	With	-32768 to 32767 (two's complement)	-327.68 to 327.67 Hz
Enabled	0	Without	0 to 65535	The rotation speed command or the machine speed command is selected depending on the Pr.37 and Pr.53 settings. (1 increments)
	1	With	-32768 to 32767 (two's complement)	

- Relationship between the start command and sign (Pr.541 = "1")

Start command	Sign of the frequency command	Actual operation command
Forward rotation	+	Forward rotation
	-	Reverse rotation
Reverse rotation	+	Reverse rotation
	-	Forward rotation

NOTE

- When Pr.541 = "1" (with sign)
 - When EEPROM write is specified by turning ON of RYE, write mode error (error code H01) will occur.
 - When both RYD and RYE are turned ON, RYD has precedence.
 - When power is turned ON (inverter reset), the initial setting status of the sign bit is "positive" and the set frequency is 0 Hz. (The motor does not operate at the frequency set before turning OFF the power (inverter reset).)
 - When set frequency is written with the instruction code of HED or HEE, the sign of the frequency command is not changed.

◆ I/O signal list

■ When Pr.544 = "0, 1, 12, 14, or 18"

- Remote I/O signals

Device No. ^{*7}	Signal	Refer to page	Device No. ^{*7}	Signal	Refer to page
RYn0	Forward rotation command ^{*2}	35	RXn0	Forward running	36
RYn1	Reverse rotation command ^{*2}	35	RXn1	Reverse running	36
RYn2	High-speed operation command (terminal RH function) ^{*1}	35	RXn2	Running (terminal RUN function) ^{*3}	36
RYn3	Middle-speed operation command (terminal RM function) ^{*1}	35	RXn3	Up to frequency ^{*2}	36
RYn4	Low-speed operation command (terminal RL function) ^{*1}	35	RXn4	Overload warning ^{*2}	36
RYn5	JOG operation selection 2 ^{*2}	35	RXn5	Pr.193 assignment function (NET Y1) ^{*6}	36
RYn6	Second function selection ^{*2}	35	RXn6	Frequency detection (terminal FU function) ^{*3}	36
RYn7	Current input selection ^{*2}	35	RXn7	Fault (terminal ABC function) ^{*3}	36
RYn8	Pr.185 assignment function (NET X1) ^{*5}	35	RXn8	Pr.194 assignment function (NET Y2) ^{*6}	36
RYn9	Output stop (terminal MRS function) ^{*1}	35	RXn9	Pr.313 assignment function (DO0) ^{*4}	36
RYnA	Pr.186 assignment function (NET X2) ^{*5}	35	RXnA	Pr.314 assignment function (DO1) ^{*4}	36
RYnB	Pr.184 assignment function (RES) ^{*5}	35	RXnB	Pr.315 assignment function (DO2) ^{*4}	36
RYnC	Monitor command	35	RXnC	Monitoring	37
RYnD	Frequency setting command (RAM)	36	RXnD	Frequency setting completion (RAM)	37
RYnE	Frequency setting command (RAM, EEPROM)	36	RXnE	Frequency setting completion (RAM, EEPROM)	37
RYnF	Instruction code execution request	36	RXnF	Instruction code execution completed	37
RY(n+1)0 to RY(n+1)7	Reserved	—	RX(n+1)0 to RX(n+1)5	Reserved	—
RY(n+1)8	Not used (initial data process completion flag)	—	RX(n+1)6	Pr.195 assignment function (NET Y3) ^{*6}	37
RY(n+1)9	Not used (initial data process request flag)	—	RX(n+1)7	Pr.196 assignment function (NET Y4) ^{*6}	37
RY(n+1)A	Error reset request flag	36	RX(n+1)8	Not used (initial data process request flag)	—
RY(n+1)B	Pr.187 assignment function (NET X3) ^{*5}	36	RX(n+1)9	Not used (initial data process completion flag)	—
RY(n+1)C	Pr.188 assignment function (NET X4) ^{*5}	36	RX(n+1)A	Error status flag	37
RY(n+1)D	Pr.189 assignment function (NET X5) ^{*5}	36	RX(n+1)B	Remote station ready	37
RY(n+1)E	Reserved	—	RX(n+1)C	In-position ^{*2}	37
RY(n+1)F			RX(n+1)D	During position command operation ^{*2}	37
			RX(n+1)E	Home position return completed ^{*2}	37
			RX(n+1)F	Home position return failure ^{*2}	37

- *1 These signals are set in the initial setting. Using **Pr.180 to Pr.183**, input signals assigned to the device numbers can be changed. For details of **Pr.180 to Pr.183**, refer to the FR-E800 Instruction Manual (Function).
- *2 The signals are fixed. They cannot be changed using parameters.
- *3 These signals are set in the initial setting. Using **Pr.190 to Pr.192**, output signals assigned to the device numbers can be changed. For details of **Pr.190 to Pr.192**, refer to the FR-E800 Instruction Manual (Function).
- *4 Output signals can be assigned using **Pr.313 to Pr.315**. For details, refer to the description of **Pr.313 to Pr.315 (Output terminal function selection)** in the FR-E800 Instruction Manual (Function).
- *5 Input signals can be assigned using **Pr.184 to Pr.189**. For details, refer to the description of **Pr.184 to Pr.189 (Input terminal function selection)** in the FR-E800 Instruction Manual (Function).
- *6 Output signals can be assigned using **Pr.193 to Pr.196**. For details, refer to the description of **Pr.193 to Pr.196 (Output terminal function selection)** in the FR-E800 Instruction Manual (Function).
- *7 "n" indicates a value determined by the station number.

• Remote registers

Address ^{*5}	Description		Refer to page
	Upper 8 bits	Lower 8 bits	
RWwn	Monitor code 2	Monitor code 1	37
RWwn+1	Set frequency (0.01 Hz increments) ^{*2}		37
RWwn+2	Link parameter extended setting	Instruction code	37
RWwn+3	Data to be written		37
RWwn+4	Monitor code 3		37
RWwn+5	Monitor code 4		37
RWwn+6	Monitor code 5		37
RWwn+7	Monitor code 6		37
RWwn+8	Fault history No.	H00	38
RWwn+9	PID set point (0.01% increments) ^{*1}		38
RWwn+A	PID measured value (0.01% increments) ^{*1}		38
RWwn+B	PID deviation (0.01% increments) ^{*1}		38
RWwn+C	Torque command or torque limit		38, 49
RWwn+D	H00 (Free)		—
RWwn+E			
RWwn+F			
RWwn+10	Link parameter extended setting	Instruction code	38
RWwn+11	Data to be written		38
RWwn+12	Link parameter extended setting	Instruction code	38
RWwn+13	Data to be written		38
RWwn+14	Link parameter extended setting	Instruction code	38
RWwn+15	Data to be written		38
RWwn+16	Link parameter extended setting	Instruction code	38
RWwn+17	Data to be written		38
RWwn+18	Link parameter extended setting	Instruction code	38
RWwn+19	Data to be written		38
RWwn+1A	H00 (Free)		—
RWwn+1B			
RWwn+1C			
RWwn+1D			
RWwn+1E			
RWwn+1F			

Address ^{*5}	Description		Refer to page
	Upper 8 bits	Lower 8 bits	
RWrn	First monitor value ^{*3}		39
RWrn+1	Second monitor value ^{*3}		39
RWrn+2	Reply code 2	Reply code 1	39
RWrn+3	Data to be read		39
RWrn+4	Third monitor value ^{*3}		39
RWrn+5	Fourth monitor value ^{*3}		39
RWrn+6	Fifth monitor value ^{*3}		39
RWrn+7	Sixth monitor value ^{*3}		39
RWrn+8	Fault history No.	Fault record (fault data)	39
RWrn+9	Fault record (output frequency) ^{*4}		39
RWrn+A	Fault record (output current)		39
RWrn+B	Fault record (output voltage)		39
RWrn+C	Fault record (energization time)		39
RWrn+D	H00 (Free)		—
RWrn+E			
RWrn+F			
RWrn+10	Reply code		39
RWrn+11	Data to be read		39
RWrn+12	Reply code		39
RWrn+13	Data to be read		39
RWrn+14	Reply code		39
RWrn+15	Data to be read		39
RWrn+16	Reply code		39
RWrn+17	Data to be read		39
RWrn+18	Reply code		39
RWrn+19	Data to be read		39
RWrn+1A	H00 (Free)		—
RWrn+1B			
RWrn+1C			
RWrn+1D			
RWrn+1E			
RWrn+1F			

- *1 Validity depends on the **Pr.128**, **Pr.609**, and **Pr.610** settings. For details, refer to the FR-E800 Instruction Manual (Function). If the data outside the range is set, the previous setting is retained.
- *2 The display can be changed to rotations per minute (machine speed) using **Pr.37 and Pr.53**.
- *3 When the item displayed in frequency is selected, the **Pr.37 and Pr.53** settings are invalid.
- *4 The frequency is always displayed regardless of the settings in **Pr.37 and Pr.53**.
- *5 "n" indicates a value determined by the station number.

■ When Pr.544 = "38" (user defined cyclic communication data selection)

- Remote I/O signals

Device No. ^{*7}	Signal	Refer to page	Device No. ^{*7}	Signal	Refer to page
RYn0	Forward rotation command ^{*2}	35	RXn0	Forward running	36
RYn1	Reverse rotation command ^{*2}	35	RXn1	Reverse running	36
RYn2	High-speed operation command (terminal RH function) ^{*1}	35	RXn2	Running (terminal RUN function) ^{*3}	36
RYn3	Middle-speed operation command (terminal RM function) ^{*1}	35	RXn3	Up to frequency ^{*2}	36
RYn4	Low-speed operation command (terminal RL function) ^{*1}	35	RXn4	Overload warning ^{*2}	36
RYn5	JOG operation selection 2 ^{*2}	35	RXn5	Pr.193 assignment function (NET Y1) ^{*6}	36
RYn6	Second function selection ^{*2}	35	RXn6	Frequency detection (terminal FU function) ^{*3}	36
RYn7	Current input selection ^{*2}	35	RXn7	Fault (terminal ABC function) ^{*3}	36
RYn8	Pr.185 assignment function (NET X1) ^{*5}	35	RXn8	Pr.194 assignment function (NET Y2) ^{*6}	36
RYn9	Output stop (terminal MRS function) ^{*1}	35	RXn9	Pr.313 assignment function (DO0) ^{*4}	36
RYnA	Pr.186 assignment function (NET X2) ^{*5}	35	RXnA	Pr.314 assignment function (DO1) ^{*4}	36
RYnB	Pr.184 assignment function (RES) ^{*5}	35	RXnB	Pr.315 assignment function (DO2) ^{*4}	36
RYnC	Monitor command	35	RXnC	Monitoring	37
RYnD	Frequency setting command (RAM)	36	RXnD	Frequency setting completion (RAM)	37
RYnE	Frequency setting command (RAM, EEPROM)	36	RXnE	Frequency setting completion (RAM, EEPROM)	37
RYnF	Instruction code execution request	36	RXnF	Instruction code execution completed	37
RY(n+1)0 to RY(n+1)7	Reserved	—	RX(n+1)0 to RX(n+1)5	Reserved	—
RY(n+1)8	Not used (initial data process completion flag)	—	RX(n+1)6	Pr.195 assignment function (NET Y3) ^{*6}	37
RY(n+1)9	Not used (initial data process request flag)	—	RX(n+1)7	Pr.196 assignment function (NET Y4) ^{*6}	37
RY(n+1)A	Error reset request flag	36	RX(n+1)8	Not used (initial data process request flag)	—
RY(n+1)B	Pr.187 assignment function (NET X3) ^{*5}	36	RX(n+1)9	Not used (initial data process completion flag)	—
RY(n+1)C	Pr.188 assignment function (NET X4) ^{*5}	36	RX(n+1)A	Error status flag	37
RY(n+1)D	Pr.189 assignment function (NET X5) ^{*5}	36	RX(n+1)B	Remote station ready	37
RY(n+1)E	User defined cyclic communication input writing request	36	RX(n+1)C	In-position ^{*2}	37
RY(n+1)F	Reserved	—	RX(n+1)D	During position command operation ^{*2}	37
			RX(n+1)E	Home position return completed ^{*2}	37
			RX(n+1)F	Home position return failure ^{*2}	37

*1 The signal initially assigned to the terminal. Using **Pr.180 to Pr.183**, input signals assigned to the device numbers can be changed.

For details of **Pr.180 to Pr.183**, refer to the FR-E800 Instruction Manual (Function).

*2 The signals are fixed. They cannot be changed using parameters.

*3 These signals are set in the initial setting. Using **Pr.190 to Pr.192**, output signals assigned to the device numbers can be changed.

For details of **Pr.190 to Pr.192**, refer to the FR-E800 Instruction Manual (Function).

*4 Output signals can be assigned using **Pr.313 to Pr.315**.

For details, refer to the description of **Pr.313 to Pr.315 (Output terminal function selection)** in the FR-E800 Instruction Manual (Function).

*5 Input signals can be assigned using **Pr.184 to Pr.189**.

For details, refer to the description of **Pr.184 to Pr.189 (Input terminal function selection)** in the FR-E800 Instruction Manual (Function).

*6 Output signals can be assigned using **Pr.193 to Pr.196**.

For details, refer to the description of **Pr.193 to Pr.196 (Output terminal function selection)** in the FR-E800 Instruction Manual (Function).

*7 "n" indicates a value determined by the station number.

- Remote registers

Address ^{*3}	Description		Refer to page	Address ^{*3}	Description		Refer to page
	Upper 8 bits	Lower 8 bits			Upper 8 bits	Lower 8 bits	
RWwn	Monitor code 2	Monitor code 1	38	RWrn	First monitor value ^{*2}		39
RWwn+1	Set frequency (0.01 Hz increments) ^{*1}		38	RWrn+1	Second monitor value ^{*2}		39

Address ^{*3}	Description		Refer to page
	Upper 8 bits	Lower 8 bits	
RWwn+2	Link parameter extended setting	Instruction code	38
RWwn+3	Data to be written		38
RWwn+4	User Defined Cyclic Communication Input 1 Mapping (Pr.1320), lower 16 bits		39
RWwn+5	User Defined Cyclic Communication Input 1 Mapping (Pr.1320), upper 16 bits		39
RWwn+6	User Defined Cyclic Communication Input 2 Mapping (Pr.1321), lower 16 bits		39
RWwn+7	User Defined Cyclic Communication Input 2 Mapping (Pr.1321), upper 16 bits		39
RWwn+8	User Defined Cyclic Communication Input 3 Mapping (Pr.1322), lower 16 bits		39
RWwn+9	User Defined Cyclic Communication Input 3 Mapping (Pr.1322), upper 16 bits		39
RWwn+A	User Defined Cyclic Communication Input 4 Mapping (Pr.1323), lower 16 bits		39
RWwn+B	User Defined Cyclic Communication Input 4 Mapping (Pr.1323), upper 16 bits		39
RWwn+C	User Defined Cyclic Communication Input 5 Mapping (Pr.1324), lower 16 bits		39
RWwn+D	User Defined Cyclic Communication Input 5 Mapping (Pr.1324), upper 16 bits		39
RWwn+E	User Defined Cyclic Communication Input 6 Mapping (Pr.1325), lower 16 bits		39
RWwn+F	User Defined Cyclic Communication Input 6 Mapping (Pr.1325), upper 16 bits		39
RWwn+10	User Defined Cyclic Communication Input 7 Mapping (Pr.1326), lower 16 bits		39
RWwn+11	User Defined Cyclic Communication Input 7 Mapping (Pr.1326), upper 16 bits		39
RWwn+12	User Defined Cyclic Communication Input 8 Mapping (Pr.1327), lower 16 bits		39
RWwn+13	User Defined Cyclic Communication Input 8 Mapping (Pr.1327), upper 16 bits		39
RWwn+14	User Defined Cyclic Communication Input 9 Mapping (Pr.1328), lower 16 bits		39
RWwn+15	User Defined Cyclic Communication Input 9 Mapping (Pr.1328), upper 16 bits		39
RWwn+16	User Defined Cyclic Communication Input 10 Mapping (Pr.1329), lower 16 bits		39
RWwn+17	User Defined Cyclic Communication Input 10 Mapping (Pr.1329), upper 16 bits		39

Address ^{*3}	Description		Refer to page
	Upper 8 bits	Lower 8 bits	
RWrn+2	Reply code 2	Reply code 1	39
RWrn+3	Data to be read		40
RWrn+4	User Defined Cyclic Communication Output 1 Mapping (Pr.1330), lower 16 bits		40
RWrn+5	User Defined Cyclic Communication Output 1 Mapping (Pr.1330), upper 16 bits		40
RWrn+6	User Defined Cyclic Communication Output 2 Mapping (Pr.1331), lower 16 bits		40
RWrn+7	User Defined Cyclic Communication Output 2 Mapping (Pr.1331), upper 16 bits		40
RWrn+8	User Defined Cyclic Communication Output 3 Mapping (Pr.1332), lower 16 bits		40
RWrn+9	User Defined Cyclic Communication Output 3 Mapping (Pr.1332), upper 16 bits		40
RWrn+A	User Defined Cyclic Communication Output 4 Mapping (Pr.1333), lower 16 bits		40
RWrn+B	User Defined Cyclic Communication Output 4 Mapping (Pr.1333), upper 16 bits		40
RWrn+C	User Defined Cyclic Communication Output 5 Mapping (Pr.1334), lower 16 bits		40
RWrn+D	User Defined Cyclic Communication Output 5 Mapping (Pr.1334), upper 16 bits		40
RWrn+E	User Defined Cyclic Communication Output 6 Mapping (Pr.1335), lower 16 bits		40
RWrn+F	User Defined Cyclic Communication Output 6 Mapping (Pr.1335), upper 16 bits		40
RWrn+10	User Defined Cyclic Communication Output 7 Mapping (Pr.1336), lower 16 bits		40
RWrn+11	User Defined Cyclic Communication Output 7 Mapping (Pr.1336), upper 16 bits		40
RWrn+12	User Defined Cyclic Communication Output 8 Mapping (Pr.1337), lower 16 bits		40
RWrn+13	User Defined Cyclic Communication Output 8 Mapping (Pr.1337), upper 16 bits		40
RWrn+14	User Defined Cyclic Communication Output 9 Mapping (Pr.1338), lower 16 bits		40
RWrn+15	User Defined Cyclic Communication Output 9 Mapping (Pr.1338), upper 16 bits		40
RWrn+16	User Defined Cyclic Communication Output 10 Mapping (Pr.1339), lower 16 bits		40
RWrn+17	User Defined Cyclic Communication Output 10 Mapping (Pr.1339), upper 16 bits		40

Address ^{*3}	Description		Refer to page	Address ^{*3}	Description		Refer to page
	Upper 8 bits	Lower 8 bits			Upper 8 bits	Lower 8 bits	
RWwn+18	H00 (Free)		—	RWrn+18	User Defined Cyclic Communication Output 11 Mapping (Pr.1340), lower 16 bits	40	
RWwn+19				RWrn+19	User Defined Cyclic Communication Output 11 Mapping (Pr.1340), upper 16 bits	40	
RWwn+1A				RWrn+1A	User Defined Cyclic Communication Output 12 Mapping (Pr.1341), lower 16 bits	40	
RWwn+1B				RWrn+1B	User Defined Cyclic Communication Output 12 Mapping (Pr.1341), upper 16 bits	40	
RWwn+1C				RWrn+1C	User Defined Cyclic Communication Output 13 Mapping (Pr.1342), lower 16 bits	40	
RWwn+1D				RWrn+1D	User Defined Cyclic Communication Output 13 Mapping (Pr.1342), upper 16 bits	40	
RWwn+1E				RWrn+1E	User Defined Cyclic Communication Output 14 Mapping (Pr.1343), lower 16 bits	40	
RWwn+1F				RWrn+1F	User Defined Cyclic Communication Output 14 Mapping (Pr.1343), upper 16 bits	40	

*1 The display can be changed to rotations per minute (machine speed) using Pr.37 and Pr.53.

*2 When the item displayed in frequency is selected, the Pr.37 and Pr.53 settings are invalid.

*3 "n" indicates a value determined by the station number.

◆ Details of the I/O signals

The device numbers described in this section are for the station number 1. For the station number 2 and later, the device numbers are different. (Refer to the manual for the CC-Link master module for the correspondence between device numbers and station numbers.)

■ Output signals (from the master module to the inverter)

Output signals from the master module are as follows. (Input signals to the inverter)

Device No.	Signal	Description	
RY0	Forward rotation command ^{*2}	0: Stop command 1: Forward rotation start	When "1" is set, a start command is input to the inverter. When "1" is set in RY0 and RY1, a stop command is input.
RY1	Reverse rotation command ^{*2}	0: Stop command 1: Reverse rotation start	
RY2	High-speed operation command (terminal RH function) ^{*1}	Functions assigned to Pr.180 to Pr.182 are activated.	
RY3	Middle-speed operation command (terminal RM function) ^{*1}		
RY4	Low-speed operation command (terminal RL function) ^{*1}		
RY5	JOG operation selection 2 ^{*2}	JOG2 signal	
RY6	Second function selection ^{*2}	RT signal	
RY7	Current input selection ^{*2}	AU signal	
RY8	— (terminal NET X1 function) ^{*3}	The function assigned to Pr.185 is activated.	
RY9	Output stop (terminal MRS function) ^{*1}	The function assigned to Pr.183 is activated.	
RYA	— (terminal NET X2 function) ^{*3}	The function assigned to Pr.186 is activated.	
RYB	— (Function of terminal RES) ^{*3}	The function assigned to Pr.184 is activated.	
RYC	Monitor command	When "1" is set in RYC, the monitored value is set in the remote register RWr0, 1, 4 to 7, and "1" is set in RXC (device for the Monitoring signal). While "1" is set in RYC, the monitored data is always updated.	

Device No.	Signal	Description
RYD	Frequency setting command / torque command (RAM)	When "1" is set in RYD, the set frequency / torque command (RWw1) is written to the RAM of the inverter. ^{*4} After the writing completes, "1" is set in the frequency setting / torque command completion (RXD). Under Real sensorless vector control, Vector control, and PM sensorless vector control, the following value is also written to RAM at the same time. • During torque control ^{*6} : Torque command value • During speed control / position control: Torque limit value
RYE	Frequency setting command / torque command (RAM, EEPROM)	When "1" is set in RYE, the set frequency / torque command (RWw1) is written to the RAM and EEPROM of the inverter. After the writing completes, "1" is set in the frequency setting / torque command completion (RXE). Under Real sensorless vector control, Vector control, and PM sensorless vector control, the following value is also written to RAM and EEPROM at the same time. • During torque control ^{*6} : Torque command value • During speed control / position control: Torque limit value To change the frequency consecutively, be sure to write data to the inverter RAM.
RYF	Instruction code execution request	At the ON edge of RYF, processing corresponding to the instruction codes set to RWw2, 10, 12, 14, 16, and 18 are executed. "1" is set in the instruction code execution completed (RXF) after completion of instruction codes. When an instruction code execution error occurs, a value other than "0" is set in the reply code (RWr2, 10, 12, 14, 16, or 18).
RY1A	Error reset request flag	When "1" is set in RY1A at an inverter fault, the inverter is reset, and then "0" is set in the error status flag (RX1A). ^{*5}
RY1B	— (terminal NET X3 function) ^{*3}	Functions assigned to Pr.187 to Pr.189 are activated.
RY1C	— (terminal NET X4 function) ^{*3}	
RY1D	— (terminal NET X5 function) ^{*3}	
RY1E	User defined cyclic communication input writing request	

*1 These signals are set in the initial setting. Using **Pr.180 to Pr.183**, input signals assigned to the device numbers can be changed. Some signals are not controllable via network depending on the settings of **Pr.338 and Pr.339**. For details of **Pr.180 to Pr.183, Pr.338, and Pr.339**, refer to the FR-E800 Instruction Manual (Function).

*2 The signals are fixed. They cannot be changed using parameters.

*3 No signal is assigned in the initial setting. Use **Pr.184 to Pr.189** to assign signals to RY8, RYA, RYB, and RY1B to RY1D. For details, refer to the description of **Pr.184 to Pr.189 (Input terminal function selection)** in the FR-E800 Instruction Manual (Function).

*4 While "1" is set in the frequency setting command (RYD), the set frequency (RWw1) is always applied.

*5 Refer to [page 287](#) for operation conditions of inverter reset.

*6 Torque control cannot be performed with a PM motor.

■ Input signals (from the inverter to the master module)

Input signals to the master module are as follows. (Output signals from the inverter)

Device No.	Signal	Description
RX0	Forward running	0: Other than forward running (during stop or reverse rotation) 1: Forward running
RX1	Reverse running	0: Other than reverse running (during stop or forward rotation) 1: Reverse running
RX2	Running (terminal RUN function) ^{*1}	The function assigned to Pr.190 is activated.
RX3	Up to frequency ^{*2}	SU signal
RX4	Overload warning ^{*2}	OL signal
RX5	— (terminal NET Y1 function) ^{*4}	The function assigned to Pr.193 is activated.
RX6	Frequency detection (terminal FU function) ^{*1}	The function assigned to Pr.191 is activated.
RX7	Fault (terminal ABC function) ^{*1}	The function assigned to Pr.192 is activated.
RX8	— (terminal NET Y2 function) ^{*4}	The function assigned to Pr.194 is activated.
RX9	— (DO0 function) ^{*3}	Functions assigned to Pr.313 to Pr.315 are activated.
RXA	— (DO1 function) ^{*3}	
RXB	— (DO2 function) ^{*3}	

Device No.	Signal	Description
RXC	Monitoring	After "1" is set in the monitor command (RYC), and the monitored value is set in the remote register Rwr0, 1, 4 to 7, "1" is set for this signal. When "0" is set in the monitor command (RYC), "0" is set for this signal.
RXD	Frequency setting / torque command completed (RAM)	After "1" is set in the frequency setting command / torque command (RYD), and the frequency setting / torque command is written to the RAM of the inverter, "1" is set for this signal. When "0" is set in the frequency setting command / torque command (RYD), "0" is set for this signal.
RXE	Frequency setting / torque command completed (RAM, EEPROM)	After "1" is set in the frequency setting command / torque command (RYE), and the frequency setting / torque command is written to the RAM and EEPROM of the inverter, "1" is set for this signal. When "0" is set in the frequency setting command / torque command (RYE), "0" is set for this signal.
RXF	Instruction code execution completed	After "1" is set in the instruction code execution request (RYF) and the processes corresponding to the instruction codes (RWw2, 10, 12, 14, 16 and 18) are executed, "1" is set for this signal. When "0" is set in the instruction code execution request (RYF), "0" is set for this signal.
RX16	— (terminal NET Y3 function) ^{*4}	Functions assigned to Pr.195 and Pr.196 are activated.
RX17	— (terminal NET Y4 function) ^{*4}	
RX1A	Error status flag	When an inverter error occurs (protective function is activated), "1" is set for this signal.
RX1B	Remote station ready	When the inverter is ready for communication upon completion of initial setting after power-ON or a hardware reset, "1" is set for this signal. When an inverter error occurs (protective function is activated), "0" is set in this signal.
RX1C	In-position ^{*2}	Y36 signal
RX1D	During position command operation ^{*2}	PBSY signal
RX1E	Home position return completed ^{*2}	ZP signal
RX1F	Home position return failure ^{*2}	ZA signal

*1 These signals are set in the initial setting. Using **Pr.190** to **Pr.192**, output signals assigned to the device numbers can be changed. For details of **Pr.190** to **Pr.192**, refer to the FR-E800 Instruction Manual (Function).

*2 The signals are fixed. They cannot be changed using parameters.

*3 No signal is assigned in the initial setting. Use **Pr.313** to **Pr.315** to assign signals to RX9 to RXB.

For details, refer to the description of **Pr.313** to **Pr.315 (Output terminal function selection)** in the FR-E800 Instruction Manual (Function).

*4 No signal is assigned in the initial setting. Use **Pr.193** to **Pr.196** to assign signals to RX5, RX8, RX16, and RX17.

For details, refer to the description of **Pr.193** to **Pr.196 (Output terminal function selection)** in the FR-E800 Instruction Manual (Function).

◆ Details of the remote register

■ Remote register (from the master module to the inverter)

- Remote register description (when **Pr.544** = "0, 1, 12, 14, or 18")

Device No.	Signal	Description
RWw0	Monitor code 1, 2	Set the monitor code to be monitored (refer to page 42). When "1" is set in RYC, data of the specified monitor item will be stored in RWr0 and RWr1.
RWw1	Set frequency ^{*1*2}	Specify the set frequency or rotations per minute (machine speed). At this time, whether to write to the RAM or EEPROM is decided with the RYD and RYE settings. After setting the set frequency in this register, set "1" in RYD or RYE to write the frequency. After writing of frequency is completed, "1" is set in RXD or RXE in response to the input command. The setting range is 0 to 590.00 Hz (0.01 Hz increments). Write "59000" when setting 590.00 Hz.
RWw2	Link parameter extended setting / instruction code	Set an instruction code (refer to page 40) for an operation such as operation mode switching, parameter read/write, error reference, and error clear. Set "1" in RYF to execute the corresponding instruction after completing the register setting. "1" is set in RXF after completing the execution of the instruction. The upper 8 bits are used for the link parameter extended setting. Example) When reading Pr.160 , instruction code is H0200.
RWw3	Data to be written	Set data for the instruction code set in RWw2 (when required). Set "1" in RYF after setting RWw2 and this register. Set "0" when the write code is not required.
RWw4	Monitor code 3	Set the monitor code to be monitored. By setting "1" in RYC after setting, the specified monitor data is stored in RWr4 to RWr7.
RWw5	Monitor code 4	
RWw6	Monitor code 5	
RWw7	Monitor code 6	

Device No.	Signal	Description
RWw8	Fault history No.	Set the individual fault number of the fault history that you want to read. Fault records can be read back to the tenth latest fault. (The value in the lower 8 bits is fixed to H00.) Upper 8 bits: H00 (latest fault) to H09 (tenth latest fault) When H0A to HFF is set to the lower 8 bits, "0" is returned.
RWw9	PID set point ^{*3}	Set the PID action set point. Setting range: 0 to 100.00%
RWwA	PID measured value ^{*3}	Set the PID measured value. Setting range: 0 to 100.00%
RWwB	PID deviation ^{*3}	Set the PID deviation. Setting range: -100.00% to 100.00%
RWwC	Torque command value	When Pr.804 = "3 or 5" during torque control under Real sensorless vector control or Vector control, torque command values can be specified. The value is written to the inverter either by RYD or RYE. The values in Pr.805 and Pr.806 are updated at the same time. The setting range and the setting increment depend on the Pr.804 setting. If the data outside the range is set, the previous setting is retained.
	Torque limit value	Set Pr.804 = "3 or 5" and Pr.810 Torque limit input method selection = "2" to specify the torque limit value during speed control or position control under Real sensorless vector control, Vector control, or PM sensorless vector control. The value is written to the inverter either by RYD or RYE. The values in Pr.805 and Pr.806 are updated at the same time. The setting range and the setting increment depend on the Pr.804 setting (absolute value). If the data outside the range is set, the previous setting is retained.
RWw10, RWw12, RWw14, RWw16, RWw18	Link parameter extended setting / instruction code	Set an instruction code (refer to page 40) for an operation such as operation mode switching, parameter read/write, error reference, and error clear. The instructions are executed in the following order by setting "1" in RYF after completing the register setting: RWw2, 10, 12, 14, 16, then 18. After completing the execution up to RWw18, "1" is set in RXF. Set HFFFF to disable an instruction by RWw10 to 18. (The instruction code of RWw2 is always executed.) The upper 8 bits are used for the link parameter extended setting. Example) When reading Pr.160 , instruction code is H0200.
RWw11, RWw13, RWw15, RWw17, RWw19	Data to be written	Set the data specified by the instruction code of RWw10, 12, 14, 16, and 18 (when required). RWw10 and 11, 12 and 13, 14 and 15, 16 and 17, and 18 and 19 correspond each other. Set "1" in RYF after setting the instruction codes (RWw10, 12, 14, 16, and 18) and the corresponding register. Set "0" when the write data is not required.

*1 The display can be changed to rotations per minute (machine speed) using **Pr.37 and Pr.53**. For details, refer to the FR-E800 Instruction Manual (Function).

*2 When **Pr.541 Frequency command sign selection** = "1", the set frequency is a signed value. When the setting value is negative, the command is the inverse from the start command.

Setting range: -327.68 to 327.67 Hz (-32768 to 32767), 0.01 Hz increments.

For the details, refer to [page 30](#).

*3 Validity depends on the **Pr.128, Pr.609, and Pr.610** settings. For details, refer to the FR-E800 Instruction Manual (Function). If the data outside the range is set, the previous setting is retained.

• Remote register description (when **Pr.544** = "38")

Device No.	Signal	Description
RWw0	Monitor code 1, 2	Set the monitor code to be monitored (refer to page 42). When "1" is set in RYC, data of the specified monitor item will be stored in RWr0 and RWr1.
RWw1	Set frequency ^{*1*2}	Specify the set frequency or rotations per minute (machine speed). At this time, whether to write to the RAM or EEPROM is decided with the RYD and RYE settings. After setting the set frequency in this register, set "1" in RYD or RYE to write the frequency. After writing of frequency is completed, "1" is set in RXD or RXE in response to the input command. The setting range is 0 to 590.00 Hz (0.01 Hz increments). Write "59000" when setting 590.00 Hz.
RWw2	Link parameter extended setting / instruction code	Set an instruction code (refer to page 40) for an operation such as operation mode switching, parameter read/write, error reference, and error clear. Set "1" in RYF to execute the corresponding instruction after completing the register setting. "1" is set in RXF after completing the execution of the instruction. The upper 8 bits are used for the link parameter extended setting. Example) When reading Pr.160 , instruction code is H0200.
RWw3	Data to be written	Set data for the instruction code set in RWw2 (when required). Set "1" in RYF after setting RWw2 and this register. Set "0" when the write code is not required.

Device No.	Signal	Description
RWw4 to RWw17	User defined cyclic communication input data selection	Data set in RWw4 to RWw17 are written to the corresponding parameters that have the index numbers specified using Pr.1320 to Pr.1329 . When "20488 or 20489" is set in any of Pr.1320 to Pr.1329 , the input value set in the corresponding register is invalid. While "1" is set in RY1E, the data is always updated. If the same index number is specified in two or more of Pr.1320 to Pr.1329 , the number set in the parameter with the smallest parameter number is valid. The same number set in the other parameters is regarded as "9999". When a nonexistent index number or "9999" is set in Pr.1320 to Pr.1329 , the data will be ignored. When the referenced index number is set for 16-bit data, the upper 16-bit data will be ignored.

*1 The display can be changed to rotations per minute (machine speed) using **Pr.37 and Pr.53**. For details, refer to the FR-E800 Instruction Manual (Function).

*2 When **Pr.541 Frequency command sign selection** = "1", the set frequency is a signed value. When the setting value is negative, the command is the inverse from the start command.

Setting range: -327.68 to 327.67 Hz (-32768 to 32767), 0.01 Hz increments.

For the details, refer to [page 30](#).

■ Remote register (from the inverter to the master module)

- Remote register description (when **Pr.544** = "0, 1, 12, 14, or 18")

Device No.	Signal	Description
RWr0	First monitor value ^{*1*2}	When "1" is set in RYC, the monitor value is set to the lower 8 bits of the monitor code (RWw0).
RWr1	Second monitor value (output frequency ^{*1*2})	When "0" is set to the upper 8 bits of the monitor code (RWw0), the current output frequency is set. When "1" is set in RYC while a value other than "0" is set to the upper 8 bits of the monitor code (RWw0), the monitor value is set to the upper 8 bits of the monitor code (RWw0).
RWr2	Reply code 1	Lower 8 bits of RWr2. When "1" is set in RYD or RYE, the reply code for the frequency setting command (torque command / torque limit) is set. (Refer to page 40 .)
	Reply code 2	Upper 8 bits of RWr2. When "1" is set in RYF, the reply code corresponding to the instruction code RWw2 is set. (Refer to page 40 .)
RWr3	Data to be read	In a normal reply, a replay code for the instruction code is set.
RWr4	Third monitor value ^{*1*2}	When "1" is set in RYC, the monitor value specified to the corresponding monitor code (RWw4 to RWw7) is stored.
RWr5	Fourth monitor value ^{*1*2}	
RWr6	Fifth monitor value ^{*1*2}	
RWr7	Sixth monitor value ^{*1*2}	
RWr8	Fault record (fault data)	
RWr9	Fault record (output frequency) ^{*3}	The output frequency of the fault history No. specified in RWw8 is stored.
RWrA	Fault record (output current)	The output current of the fault history No. specified in RWw8 is always stored.
RWrB	Fault record (output voltage)	The output voltage of the fault history No. specified in RWw8 is always stored.
RWrC	Fault record (energization time)	The energization time at the fault is always stored for the fault record No. specified in RWw8.
RWr10 to RWr19	Reply code	When "1" is set in RYF, the reply codes corresponding to the instruction code RWw10, 12, 14, 16, and 18 are set. The value "0" is set for a normal reply, and a value other than "0" is set for faults with data, mode, and others. (Refer to page 40 .)
	Data to be read	In a normal reply, a replay code for the instruction code is set.

*1 When the item displayed in frequency is selected, the **Pr.37 and Pr.53** settings are invalid.

*2 Use **Pr.290** to enable display of negative numbers during monitoring. For details, refer to the FR-E800 Instruction Manual (Function).

*3 The frequency is always displayed regardless of the settings in **Pr.37 and Pr.53**.

- Remote register description (when **Pr.544** = "38")

Device No.	Signal	Description
RWr0	First monitor value ^{*1*2}	When "1" is set in RYC, the monitor value is set to the lower 8 bits of the monitor code (RWw0).
RWr1	Second monitor value (output frequency ^{*1*2})	When "0" is set to the upper 8 bits of the monitor code (RWw0), the current output frequency is set. When "1" is set in RYC while a value other than "0" is set to the upper 8 bits of the monitor code (RWw0), the monitor value is set to the upper 8 bits of the monitor code (RWw0).
RWr2	Reply code 1	Lower 8 bits of RWr2. When "1" is set in RYD or RYE, the reply code for the frequency setting command (torque command / torque limit) is set. (Refer to page 40 .)
	Reply code 2	Upper 8 bits of RWr2. When "1" is set in RYF, the reply code corresponding to the instruction code RWw2 is set. (Refer to page 40 .)

Device No.	Signal	Description
RWr3	Data to be read	In a normal reply, a replay code for the instruction code is set.
RWr4 to RWr1F	User defined cyclic communication output data selection	Data to which the index numbers are specified using Pr.1330 to Pr.1343 are always stored in the corresponding registers. When a nonexistent index number or "9999" is set in Pr.1330 to Pr.1343 , "0" is always stored. When the referenced index number is set for 16-bit data, "0" is always stored in the upper 16-bit data.

*1 When the item displayed in frequency is selected, the **Pr.37 and Pr.53** settings are invalid.

*2 Use **Pr.290** to enable display of negative numbers during monitoring. For details, refer to the FR-E800 Instruction Manual (Function).

• Reply code description

The reply to the instruction execution command is set in RWr2, 10, 12, 14, 16, and 18. After the frequency setting (RYD or RYE) or execution of instruction code (RYF), check the reply code (RWr2) in the remote register.

Item	Data	Item	Fault description	Remarks
Reply code	H0000	Normal	No fault (Instruction codes are executed without any fault.)	Reply code to RWr10, 12, 14, 16, 18
	H0001	Write mode fault	Parameter write is attempted when the inverter is not in the stop status in the Network operation mode.	
	H0002	Parameter selection fault	Unregistered code is set.	
	H0003	Setting range fault	Set data exceeds the permissible range.	
Reply code 1*1	H00	Normal	No fault (Instruction codes are executed without any fault.)	Reply code to RWr2
	H01	Write mode fault	Parameter write is attempted when the inverter is not in the stop status in the Network operation mode.	
	H03	Frequency command (torque command / torque limit) setting range error	The value outside the range is set.	
Reply code 2	H00	Normal	No fault (Instruction codes are executed without any fault.)	
	H01	Write mode fault	Parameter write is attempted when the inverter is not in the stop status in the Network operation mode.	
	H02	Parameter selection fault	Unregistered code is set.	
	H03	Setting range fault	Set data exceeds the permissible range.	

*1 The contents of the reply code 1 are changed when torque commands are given or the torque is limited. The upper 4 bits of the reply code 1 are used as the reply code to the torque command / torque limit, and the lower 4 bits are used as the reply code to the frequency command.

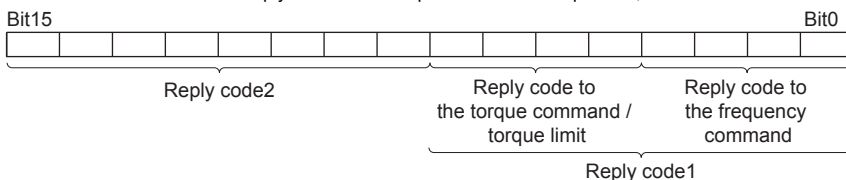

Example) When the torque command is out of the setting range, the data is H0030.

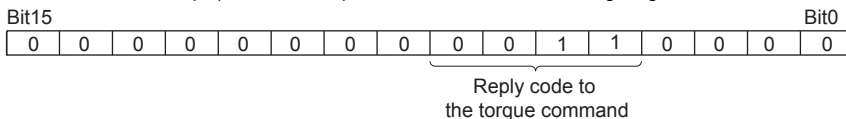

■ Instruction code

Set instruction codes using the remote register (RWw). (Refer to [page 37](#).)

The definition read by the instruction code is stored in the remote register (RWr). (Refer to [page 39](#).)

Item	Read/write	Instruction code	Data description
Operation mode	Read	H7B	H0000: Network operation H0001: External operation, External JOG operation H0002: PU operation, External/PU combined operation 1 or 2, PUJOG operation
	Write	HFB	H0000: Network operation H0001: External operation H0002: PU operation (when Pr.79 = "6")

Item		Read/write	Instruction code	Data description
Monitor	Output frequency / rotations per minute (machine speed) ^{*1*2}	Read	H6F	H0000 to HFFFF Output frequency in 0.01 Hz increments (The display can be changed to the rotations per minute (machine speed) using Pr.37 and Pr.53 . Refer to the FR-E800 Instruction Manual (Function).)
	Output current	Read	H70	H0000 to HFFFF Output current (hexadecimal) in 0.01 A increments
	Output voltage	Read	H71	H0000 to HFFFF Output voltage (hexadecimal) in 0.1 V increments
	Special monitor ^{*2}	Read	H72	H0000 to HFFFF: Monitor data selected in the instruction code HF3
	Special monitor selection No.	Read	H73	H01 to HFF: Monitor selection data
		Write	HF3 ^{*3}	Refer to the monitor code description on page 42 .
Fault record	Read	H74 to H78	<p>H0000 to HFFFF: Two fault records per code For data codes and details of fault records, refer to the FR-E800 Instruction Manual (Maintenance).</p> <p>For instruction code H74, read data H30A0</p>	
Set frequency (RAM)	Read	H6D	Read the set frequency or rotations per minute (machine speed) from the RAM or EEPROM. H0000 to HE678: Set frequency in 0.01 Hz increments (The display can be changed to the rotations per minute (machine speed) using Pr.37 and Pr.53 . Refer to the FR-E800 Instruction Manual (Function).)	
Set frequency (EEPROM)		H6E		
Set frequency (RAM) ^{*4}	Write	HED	Write the set frequency or rotations per minute (machine speed) into the RAM or EEPROM. H0000 to HE678 (0 to 590.00 Hz): Frequency in 0.01 Hz increments. (The display can be changed to the rotations per minute (machine speed) using Pr.37 and Pr.53 . Refer to the FR-E800 Instruction Manual (Function).) To change the set frequency consecutively, write data to the RAM of the inverter. (Instruction code: HED)	
Set frequency (RAM and EEPROM) ^{*4}		HEE		
Parameter	Read	H00 to H63	<ul style="list-style-type: none"> Refer to the instruction codes in the FR-E800 Instruction Manual (Function) and write and/or read parameter values as required. Writing to Pr.77 and Pr.79 is disabled. When setting Pr.100 and later, set the link parameter extended setting. Set 65520 (HFFF0) as a parameter value "8888" and 65535 (HFFFF) as "9999". When changing the parameter values frequently, set "1" in Pr.342 to write them to the RAM. (For the details, refer to page 282.) 	
	Write	H80 to HE3		
Fault history clear	Write	HF4	H9696: Fault history is cleared.	
Parameter clear / All parameter clear	Write	HFC	<p>All parameters return to initial values. Whether to clear communication parameters or not can be selected according to the data.</p> <ul style="list-style-type: none"> Parameter clear H9696: Communication parameters are cleared. H5A5A^{*5}: Communication parameters are not cleared. All parameter clear H9696: Communication parameters are cleared. H55AA^{*5}: Communication parameters are not cleared. <p>For the details of whether or not to clear parameters, refer to the FR-E800 Instruction Manual (Function). When clear is performed with H9696 or H9966, communication related parameter settings also return to the initial values. When resuming the operation, set the parameters again. Performing a clear will clear the instruction code HEC, HF3, and HFF settings.</p>	
Inverter reset	Write	HFD	H9696: Resets the inverter.	
Second parameter changing ^{*6}	Read	H6C	Read or write of bias and gain parameters (instruction codes H5E to H61 and HDE to HE1 with the link parameter extended setting = "1", H11 to H23 and H91 to HA3 with the link parameter extended setting = "9").	
	Write	HEC	H00: Frequency ^{*7} H01: Parameter-set analog value H02: Analog value input from terminal	

- *1 When "100" is set in **Pr.52 Operation panel main monitor selection**, the frequency setting value is monitored during a stop, and the output frequency is monitored during running.
- *2 Use **Pr.290** to enable display of negative numbers during monitoring. For details, refer to the FR-E800 Instruction Manual (Function).
- *3 Write data in hexadecimal, and only two digits are valid. (The upper two digits are ignored.)
- *4 Setting from the remote register (RWw1) is also available.
- *5 Turning OFF the power supply while clearing parameters with H5A5A or H55AA returns the communication parameter settings to the initial settings.
- *6 Reading or writing is available when the link parameter extended setting = "1 or 9".
- *7 The gain frequency can be also written using **Pr.125** (instruction code: H99) or **Pr.126** (instruction code: H9A).

NOTE

- When a 32-bit parameter setting or monitor item is read and the value to be read exceeds HFFFF, HFFFF is returned.

Monitor code

Various data of the inverter can be monitored by setting the special monitor selection No. of the instruction code and setting the monitor code in the remote registers, RWw0 and RWw4 to 7.

- Use the monitor code (RWw0) to set the first monitor value (RWr0) in the lower 8 bits, and the second monitor value (RWr1) in the upper 8 bits.

(Example) The monitor code (RWw0) will be H0602 to set the output current as the first monitor value (RWr0) and set the running speed as the second monitor value (RWr1).

- The values for the monitor code 3 (RWw4) to the monitor code 6 (RWw7) can be selected.

Monitor code	Second monitor (upper 8 bits)	First monitor and third–sixth monitor (lower 8 bits)	Unit
H00	Output frequency	None (monitor value fixed to "0")	0.01 Hz
H01	Output frequency		0.01 Hz
H02	Output current		0.01 A
H03	Output voltage		0.1 V
.	.		.
.	.		.
.	.		.

NOTE

- The monitor codes from H01 onwards and their contents are the same as those of the RS-485 communication dedicated monitor. For details of the monitor codes or monitor items, refer to the monitor display section in the FR-E800 Instruction Manual (Function).
- When the item displayed in frequency is selected in the remote registers, RWw0 and RWw4 to RWw7, the **Pr.37 and Pr.53** settings are invalid.

◆ Communication speed and full-duplex/half-duplex selection (Pr.1426)

Use **Pr.1426 Link speed and duplex mode selection** to set the communication speed and the full-duplex or half-duplex system. If the operation is not performed properly in the initial setting (**Pr.1426** = "0"), set **Pr.1426** according to the specifications of the connected device.

Pr.1426 setting	Communication speed	Full-duplex/half-duplex system	Remarks
0 (initial value)	Automatic negotiation	Automatic negotiation	The communication speed and the communication mode (half-duplex/full-duplex) are automatically negotiated to ensure the optimum setting. To set automatic negotiation, auto negotiation setting is required also in the master station.
1	100 Mbps	Full duplex	—
2	100 Mbps	Half duplex	—
3	10 Mbps	Full duplex	The communication speed is fixed at 100 Mbps. Do not set 10 Mbps.
4	10 Mbps	Half duplex	

◆ IP filtering function (Ethernet) (Pr.1442 to Pr.1448)

- Set the IP address range for connectable network devices (**Pr.1442 to Pr.1448**) to limit the connectable devices. The setting range for IP address of connectable network devices depends on the settings in **Pr.1443** and **Pr.1446**, **Pr.1444** and **Pr.1447**, and **Pr.1445** and **Pr.1448**. (Either of the settings can be larger than the other in **Pr.1443** and **Pr.1446**, **Pr.1444** and **Pr.1447**, and **Pr.1445** and **Pr.1448**.)

[Setting example 1]

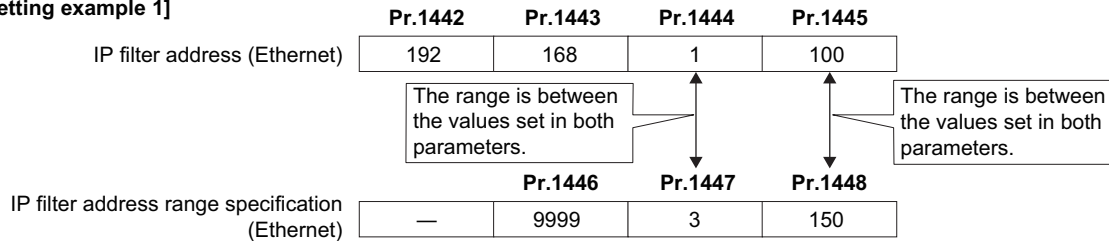

In this case, the IP address range in which Ethernet communication is permitted is "192.168.x (1 to 3).xxx (100 to 150)".

[Setting example 2]

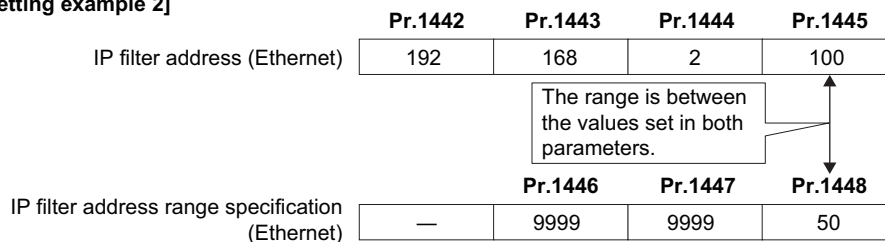

In this case, the IP address range in which Ethernet communication is permitted is "192.168.2.xxx (50 to 100)".

- When **Pr.1442 to Pr.1445** = "0 (initial value)", the function is invalid.
- When "9999 (initial value)" is set in **Pr.1446 to Pr.1448**, the range is invalid.

⚠ CAUTION

- The IP filtering function (Ethernet) (**Pr.1442 to Pr.1448**) is provided as a means to prevent unauthorized access, DoS attacks, computer viruses, or other cyberattacks from external devices, but the function does not prevent such access completely. In order to protect the inverter and the system against unauthorized access by external systems, take additional security measures. We shall have no responsibility or liability for any problems involving inverter trouble and system trouble by DoS attacks, unauthorized access, computer viruses, and other cyberattacks. The following are examples of measures to prevent them.
 - Install a firewall.
 - Install a personal computer as a relay station, and control the relaying of transmission data using an application program.
 - Install an external device as a relay station to control access rights. (For the details of external devices used to control access rights, contact the distributors of the external devices.)

◆ User defined cyclic communication data selection (Pr.1320 to Pr.1343, Pr.1389 to Pr.1398)

- To enable the user defined cyclic communication data selection, set **Pr.544** = "38".
- Users can select communication data using **Pr.1320 to Pr.1329 User Defined Cyclic Communication Input 1 to 10 Mapping** and **Pr.1330 to Pr.1343 User Defined Cyclic Communication Output 1 to 14 Mapping**.

- In **Pr.1389 to Pr.1398**, specify the subindices to which the index numbers are specified using **Pr.1320 to Pr.1339**.

Data No.	Input data selection (from the master module to the inverter)		Output data selection (from the inverter to the master module)	
	Index specification	Sub index specification	Index specification	Sub index specification
1	Pr.1320	Pr.1389 (lower 8 bits)	Pr.1330	Pr.1394 (lower 8 bits)
2	Pr.1321	Pr.1389 (upper 8 bits)	Pr.1331	Pr.1394 (upper 8 bits)
3	Pr.1322	Pr.1390 (lower 8 bits)	Pr.1332	Pr.1395 (lower 8 bits)
4	Pr.1323	Pr.1390 (upper 8 bits)	Pr.1333	Pr.1395 (upper 8 bits)
5	Pr.1324	Pr.1391 (lower 8 bits)	Pr.1334	Pr.1396 (lower 8 bits)
6	Pr.1325	Pr.1391 (upper 8 bits)	Pr.1335	Pr.1396 (upper 8 bits)
7	Pr.1326	Pr.1392 (lower 8 bits)	Pr.1336	Pr.1397 (lower 8 bits)
8	Pr.1327	Pr.1392 (upper 8 bits)	Pr.1337	Pr.1397 (upper 8 bits)
9	Pr.1328	Pr.1393 (lower 8 bits)	Pr.1338	Pr.1398 (lower 8 bits)
10	Pr.1329	Pr.1393 (upper 8 bits)	Pr.1339	Pr.1398 (upper 8 bits)
11	—	—	Pr.1340	Fixed to "0"
12	—	—	Pr.1341	
13	—	—	Pr.1342	
14	—	—	Pr.1343	

- The following tables describe the index numbers of inverter parameters (read/write), monitor data (read), inverter control parameters (read), and CiA402 drive profile (read/write).

- Inverter parameters

Index	Sub index	Read/write	Remarks
12288 to 13787 (H3000 to H35DB)	0, 1	Read/write	The inverter parameter number + 12288 (H3000) is the index number.

- Calibration parameters

Index	Sub index	Name	Description
13188 (H3384)	0	Data	C0 (Pr.900)
	1	Sub Data	—
13189 (H3385)	0	Data	C1 (Pr.901)
	1	Sub Data	—
13190 (H3386)	0	Data	C2 (Pr.902)
	1	Sub Data	C3 (Pr.902)
13191 (H3387)	0	Data	125 (Pr.903)
	1	Sub Data	C4 (Pr.903)
13192 (H3388)	0	Data	C5 (Pr.904)
	1	Sub Data	C6 (Pr.904)
13193 (H3389)	0	Data	126 (Pr.905)
	1	Sub Data	C7 (Pr.905)
13205 (H3395)*1	0	Data	C12 (Pr.917)
	1	Sub Data	C13 (Pr.917)
13206 (H3396)*1	0	Data	C14 (Pr.918)
	1	Sub Data	C15 (Pr.918)
13207 (H3397)*1	0	Data	C16 (Pr.919)
	1	Sub Data	C17 (Pr.919)
13208 (H3398)*1	0	Data	C18 (Pr.920)
	1	Sub Data	C19 (Pr.920)
13220 (H33A4)	0	Data	C38 (Pr.932)
	1	Sub Data	C39 (Pr.932)
13221 (H33A5)	0	Data	C40 (Pr.933)
	1	Sub Data	C41 (Pr.933)
13222 (H33A6)	0	Data	C42 (Pr.934)
	1	Sub Data	C43 (Pr.934)
13223 (H33A7)	0	Data	C44 (Pr.935)
	1	Sub Data	C45 (Pr.935)

*1 Available only when the FR-E8AXY is installed.

For the numbers and names of inverter parameters, refer to the parameter list of the Instruction Manual (Function).

NOTE

- Set 65520 (HFFF0) as a parameter value "8888" and 65535 (HFFFF) as "9999".
- When parameter write is performed, data are written to RAM.

- Monitor data

Index	Sub index	Read/write	Remarks
16384 to 16483 (H4000 to H4063)	0	Read	The monitor code + 16384 (H4000) is the index number.

For details of the monitor codes and monitor items, refer to the description of **Pr.52** in the Instruction Manual (Function).

NOTE

- Display of negative numbers during monitoring set in **Pr.290 Monitor negative output selection** is disabled.
- The display can be changed from the frequency to rotations per minute (machine speed) using **Pr.53**. When the machine speed is displayed, the value is incremented by one.

- Inverter control parameter

Index	Sub index	Name	Read/write	Remarks
20488 (H5008)	0	Inverter status (extended) ^{*1}	Read	Refer to page 46 .
20489 (H5009)	0	Inverter status ^{*1}	Read	Refer to page 46 .
20981 (H51F5)	0	Fault record 1	Read	Being 2 bytes in length, the data is stored as H00○○. Refer to the lowest 1 byte for the error code. (For details on error codes, refer to the list of fault displays in the Instruction Manual (Maintenance).)
20982 (H51F6)	0	Fault record 2	Read	
20983 (H51F7)	0	Fault record 3	Read	
20984 (H51F8)	0	Fault record 4	Read	
20985 (H51F9)	0	Fault record 5	Read	
20986 (H51FA)	0	Fault record 6	Read	
20987 (H51FB)	0	Fault record 7	Read	
20988 (H51FC)	0	Fault record 8	Read	
20989 (H51FD)	0	Fault record 9	Read	
20990 (H51FE)	0	Fault record 10	Read	
20992 (H5200) ^{*2}	0	Safety input status	Read	Refer to page 46 .

*1 When "20488 or 20489" is set in any of **Pr.1320 to Pr.1329**, the input value set in the corresponding register is invalid.

*2 Available for the Ethernet model only.

- Inverter status, inverter status (extended)

Inverter status		Inverter status (extended)	
Bit	Definition	Bit	Definition
0	RUN (Inverter running) ^{*1}	0	NET Y1 (0) ^{*1}
1	During forward rotation	1	NET Y2 (0) ^{*1}
2	During reverse rotation	2	NET Y3 (0) ^{*1}
3	Up to frequency	3	NET Y4 (0) ^{*1}
4	Overload warning	4	0
5	0	5	0
6	FU (Output frequency detection) ^{*1}	6	0
7	ABC (Fault) ^{*1}	7	0
8	ABC2 (0) ^{*1}	8	0
9	Safety monitor output 2	9	0
10	0	10	0
11	0	11	0
12	0	12	0
13	0	13	0
14	0	14	0
15	Fault occurrence	15	0

*1 The signal within parentheses () is assigned in the initial status. The function changes depending on the setting of **Pr.190 to Pr.197 (Output terminal function selection)**.

For details, refer to the description of **Pr.190 to Pr.197 (Output terminal function selection)** in the Instruction Manual (Function).

- Safety input status

Bit	Definition
0	0: Terminal S1 ON 1: Terminal S1 OFF (output shutoff)
1	0: Terminal S2 ON 1: Terminal S2 OFF (output shutoff)
2 to 15	0

- CiA402 drive profile

Index	Sub index	Name	Description	Read/write	Data type
24639 (H603F)	0	Error code	Error number The error code of the latest fault that occurred after power-ON or an inverter reset is returned. When no fault occurs, no error is returned. When the fault history is cleared during occurrence of a fault, no error is returned. The upper eight bits are fixed to FF, and the lower eight bits represent the error code. (HFFXX: "XX" represents the error code.) (For details on error codes, refer to the list of fault displays in the Instruction Manual (Maintenance).)	Read	Unsigned16
24643 (H6043)	0	vl velocity demand	Output frequency (r/min) ^{*1} The output frequency is read in r/min. Monitoring range: -32768 (H8000) to 32767 (H7FFF) When Pr.81 = "9999", the number of motor poles is regarded as 4.	Read	Integer16
24644 (H6044)	0	vl velocity actual value	Operation speed (r/min) ^{*1} The operation speed is read in r/min. Monitoring range: -32768 (H8000) to 32767 (H7FFF) When Pr.81 = "9999", the number of motor poles is regarded as 4.	Read	Integer16
24672 (H6060)	0	Modes of operation	Control mode: -1 (vendor specific operation mode) (fixed)	Read/write	Integer8
24673 (H6061)	0	Modes of operation display	Current control mode: -1 (vendor specific operation mode) (fixed)	Read	Integer8
24674 (H6062)	0	Position demand value	Position command (pulse) The position command before the electronic gear operation is read.	Read	Integer32
24675 (H6063)	0	Position actual internal value	Current position (pulse) The current position after the electronic gear operation is read.	Read	Integer32

Index	Sub index	Name	Description	Read/write	Data type
24676 (H6064)	0	Position actual value	Current position (pulse) The current position before the electronic gear operation is read.	Read	Integer32
24689 (H6071)	0	Target torque	Target torque (%) Set Pr.805 Torque command value (RAM) . Setting range: 600% to 1400% When the value is set in 0.1 increments, the first decimal place is rounded off. However, when Pr.804 Torque command source selection = "5 or 6", the data can be read/written in increments of 0.1.	Read/write	Integer16
24692 (H6074)	0	Torque demand	Torque demand value (%) The torque command is read.	Read	Integer16
24695 (H6077)	0	Torque actual value	Torque actual value (%) The motor torque is read.	Read	Integer16
24698 (H607A)	0	Target position	Target position (pulse) Set the target position in the direct command mode. Initial value: 0 Setting range: -2147483647 to 2147483647 (For the direct command mode, refer to the FR-E800 Instruction Manual (Function).)	Read/write	Integer32
24703 (H607F)	0	Max profile velocity	Maximum profile speed (r/min) Set Pr.18 High speed maximum frequency in r/min. Setting range: 0 to 590 Hz	Read/write	Unsigned32
24705 (H6081)	0	Profile velocity	Profile speed (r/min) Set the maximum speed in the direct command mode. Initial value: 0 Setting range: 0 to (120 × 590 Hz / Pr.81) (For the direct command mode, refer to the FR-E800 Instruction Manual (Function).)	Read/write	Unsigned32
24707 (H6083)	0	Profile acceleration	Acceleration time constant (ms) <Position control> Set the acceleration time in the direct command mode. Initial value: 5000 Setting range: 10 to 360000 The last digit is rounded off. (For example, 1358 ms becomes 1350 ms.) (For the direct command mode, refer to the FR-E800 Instruction Manual (Function).) <Other than position control> Set Pr.7 Acceleration time in ms. Setting range: 0 to 3600 s The last two digits are rounded off when Pr.21 Acceleration/ deceleration time increments = "0", and the last digit is rounded off when Pr.21 = "1".	Read/write	Unsigned32
24708 (H6084)	0	Profile deceleration	Deceleration time constant (ms) <Position control> Set the deceleration time in the direct command mode. Initial value: 5000 Setting range: 10 to 360000 The last digit is rounded off. (For example, 1358 ms becomes 1350 ms.) (For the direct command mode, refer to the FR-E800 Instruction Manual (Function).) <Other than position control> Set Pr.8 Deceleration time in ms. Setting range: 0 to 3600 s The last two digits are rounded off when Pr.21 Acceleration/ deceleration time increments = "0", and the last digit is rounded off when Pr.21 = "1".	Read/write	Unsigned32
24719 (H608F)	—	Position encoder resolution	Encoder resolution (machine side / motor side)	—	—
	0	Highest sub-index supported	Maximum value of subindex: H02 (fixed)	Read	Unsigned8
	1	Encoder increments	Encoder resolution Set Pr.369 Number of encoder pulses . Setting range: 2 to 4096	Read/write	Unsigned32
	2	Motor revolutions	Motor speed (rev): H00000001 (fixed)	Read/write	Unsigned32

Index	Sub index	Name	Description	Read/write	Data type
24721 (H6091)	—	Gear ratio	Gear ratio	—	—
	0	Highest sub-index supported	Maximum value of subindex: H02 (fixed)	Read	Unsigned8
	1	Motor revolutions	Motor shaft revolutions ^{*2} Set Pr.420 Command pulse scaling factor numerator (electronic gear numerator) . Setting range: 1 to 32767	Read/write	Unsigned32
	2	Shaft revolutions	Drive shaft revolutions ^{*2} Set Pr.421 Command pulse multiplication denominator (electronic gear denominator) . Setting range: 1 to 32767	Read/write	Unsigned32
24728 (H6098)	0	Homing method	Home position return method Set the home position return method in the direct command mode. ^{*3} (For the direct command mode and the home position return method, refer to the FR-E800 Instruction Manual (Function).)	Read/write	Integer8
24729 (H6099)	—	Homing speeds	Home position return speed	—	—
	0	Highest sub-index supported	Maximum value of subindex: H01 (fixed)	Read	Unsigned8
	1	Speed during search for switch	Motor speed during home position returning (r/min) Set the home position return speed in the direct command mode. Initial value: 120 × 2 Hz / Pr.81 Setting range: 0 to (120 × 400 Hz / Pr.81) (For the direct command mode, refer to the FR-E800 Instruction Manual (Function).)	Read/write	Unsigned32
24730 (H609A)	0	Homing acceleration	Home position return acceleration/deceleration time (ms) Set the home position return acceleration/deceleration time in the direct command mode. Initial value: 5000 Setting range: 10 to 360000 The last digit is rounded off. (For example, 1358 ms becomes 1350 ms.) (For the direct command mode, refer to the FR-E800 Instruction Manual (Function).)	Read/write	Unsigned32
24820 (H60F4)	0	Following error actual value	Droop pulse (pulse) The droop pulse before the electronic gear operation is read.	Read	Integer32
24826 (H60FA)	0	Control effort	Speed command after position loop ^{*1} The ideal speed command is read.	Read	Integer32
24828 (H60FC)	0	Position demand internal value	Position command (pulse) The position command after the electronic gear operation is read.	Read	Integer32
25858 (H6502)	0	Supported drive modes	Supported control mode: H00010000 (vendor specific operation mode)	Read	Unsigned32

*1 The value is displayed and set in r/min regardless of the settings in **Pr.53**.

The frequency is converted to the rotation speed for reading, and the setting value is converted to the frequency for writing.

*2 When parameter write is performed, data are written to RAM.

*3 The following table shows home position return methods corresponding to the Index H6098 setting values.

H6098 setting	Home position return method
-3	Data set type
-4	Stopper type (home position return direction: position pulse increasing direction)
-5 (initial value)	Ignoring the home position (servo ON position as the home position)
-7	Count type with front end reference (home position return direction: position pulse increasing direction)
-36	Stopper type (home position return direction: position pulse decreasing direction)
-39	Count type with front end reference (home position return direction: position pulse decreasing direction)
-65	Stopper type (home position return direction: start command direction)
-66	Count type with front end reference (home position return direction: start command direction)

NOTE

- The command interface in the Network operation mode is determined by the **Pr.550 NET mode operation command source selection** setting. (Refer to the FR-E800 Instruction Manual (Function).)
- When the data is read, the value is displayed with a sign regardless of the **Pr.290 Monitor negative output selection** setting.

■ Setting example

- The following table shows example settings when user defined cyclic communication data are selected (when **Pr.544** = "38"). When "1" is set in RY(n+1)E (writing request for user defined cyclic communication input data), data in RWwn+4 and RWwn+6 are written to the specified inverter parameters in the RAM. (The response time to write the data is 100 ms at the most.)

Pr.	Name	Setting example	Description	Applicable device No.
1320	User Defined Cyclic Communication Input 1 Mapping	12295 (H3007)	P.7 Acceleration time 7 (H0007) + 12288 (H3000)	RWwn+4
1321	User Defined Cyclic Communication Input 2 Mapping	12296 (H3008)	Pr.8 Deceleration time 8 (H0008) + 12288 (H3000)	RWwn+6
1330	User Defined Cyclic Communication Output 1 Mapping	12295 (H3007)	P.7 Acceleration time 7 (H0007) + 12288 (H3000)	RWrn+4
1331	User Defined Cyclic Communication Output 2 Mapping	12296 (H3008)	Pr.8 Deceleration time 8 (H0008) + 12288 (H3000)	RWrn+6
1332	User Defined Cyclic Communication Output 3 Mapping	16386 (H4002)	Monitored output current 2 (H0002) + 16384 (H4000)	RWrn+8
1333	User Defined Cyclic Communication Output 4 Mapping	12543 (H30FF)	Pr.255 Life alarm status display 255 (H00FF) + 12288 (H3000)	RWrn+A
1334	User Defined Cyclic Communication Output 5 Mapping	20981 (H51F5)	Fault record 1	RWrn+C

◆ Torque command / torque limit by CC-Link IE TSN

Torque commands can be given or the torque can be limited by CC-Link IE TSN communication under Real sensorless vector control, Vector control, or PM sensorless vector control. The value is used to limit the torque during speed control or position control, and to give a torque command during torque control. To limit the torque, set **Pr.810 Torque limit input method selection** = "2". The torque command / torque limit setting method can be selected using **Pr.804 Torque command source selection**. (Torque control cannot be performed with a PM motor.)

Pr.	Name	Initial value	Setting range	Description
804	Torque command source selection	0	0	Torque command given by analog input via terminal 4
			1	Torque command / torque limit by CC-Link IE TSN • Torque command / torque limit (-400% to 400%) by the parameter setting (Pr.805 or Pr.806)*1*2
			3	Torque command / torque limit by CC-Link IE TSN • Torque command / torque limit (-400% to 400%) by the parameter setting (Pr.805 or Pr.806)*1*2 • Setting is available using the remote register RWw1 or RWwC (-400% to 400%).*2
			4	Torque command given by 16-bit digital input (FR-A8AX)
			5	Torque command / torque limit by CC-Link IE TSN • Torque command / torque limit (-327.68% to 327.67%) by the parameter setting (Pr.805 or Pr.806)*1*2 • Setting is available using the remote register RWw1 or RWwC (-327.68% to 327.67%).*2
			6	Torque command / torque limit by CC-Link IE TSN • Torque command / torque limit (-327.68% to 327.67%) by the parameter setting (Pr.805 or Pr.806)*1*2
810	Torque limit input method selection	0	0	Internal torque limit (torque limited by parameter settings)
			1	External torque limit (torque limited by terminal 4)
			2	Internal torque limit 2 (torque limited by CC-Link IE TSN)

*1 The value can also be set using the operation panel.

*2 When a negative value is set as the torque limit, the torque is limited by the absolute value.

■ List of I/O devices whose function is changed according to the control method

I/O device	V/F control / Advanced magnetic flux vector control	Real sensorless vector control / Vector control / PM sensorless vector control	
		Speed control / position control	Torque control ^{*3}
RYD	Frequency setting command (RAM)	Frequency setting / torque limit command (RAM)	Torque command (RAM)
RYE	Frequency setting command (RAM, EEPROM)	Frequency setting / torque limit command (RAM, EEPROM)	Torque command (RAM, EEPROM)
RXD	Frequency setting completion (RAM)	Frequency setting / torque limit completion (RAM)	Torque command completion (RAM)
RXE	Frequency setting completion (RAM, EEPROM)	Frequency setting / torque limit completion (RAM, EEPROM)	Torque command completion (RAM, EEPROM)
RWw1	Set frequency	Set frequency	—
RWwC	—	Torque limit ^{*1*2}	Torque command ^{*1}

*1 Set Pr.804 = "3 or 5".

*2 Set Pr.810 = "2".

*3 Torque control cannot be performed with a PM motor.

■ Torque command setting method and the parameter for speed limit

Pr.804 setting	Torque command setting method (any one of the following)	Parameter for speed limit
3, 5	<ul style="list-style-type: none"> Set the torque command value in RWwn+C, and "1" in RYD or RYE. Set H08 in the link parameter extended setting, the instruction code H85 and H86 in RWwn+2, the torque command value in RWwn+3, and "1" in RYF. (Writing in Pr.805 or Pr.806) 	Pr.807
1, 6	Set H08 in the link parameter extended setting, the instruction code H85 and H86 in RWwn+2, the torque command value in RWwn+3, and "1" in RYF. (Writing in Pr.805 or Pr.806)	
0, 4	Torque command cannot be given by CC-Link IE TSN.	

■ Torque limit setting method

Pr.804 setting	Pr.810 setting	Torque limit setting method (any one of the following)
3, 5	2	<ul style="list-style-type: none"> Set the torque limit value in RWwn+C, and "1" in RYD or RYE. Set H08 in the link parameter extended setting, the instruction code H85 and H86 in RWwn+2, the torque limit value in RWwn+3, and "1" in RYF. (Writing in Pr.805 or Pr.806)
1, 6		Set H08 in the link parameter extended setting, the instruction code H85 and H86 in RWwn+2, the torque limit value in RWwn+3, and "1" in RYF. (Writing in Pr.805 or Pr.806)

■ Relationship between the Pr.804 setting, the setting range, and the actual torque command / torque limit (when setting is made from CC-Link IE TSN communication)

Pr.804 setting	Setting range	Actual torque command	Actual torque limit
1, 3	600 to 1400 (1% increments) ^{*1}	-400 to 400%	0 to 400%
5, 6	-32768 to 32767 (two's complement) ^{*1}	-327.68 to 327.67%	0 to 327.67%

*1 The torque limit setting is defined as an absolute value.

◆ Programming examples

The following explains the programming examples for controlling the inverter with sequence programs.

Item	Sample program	Refer to page
Reading the inverter status	Reading the inverter status from the buffer memory of the master station	53
Setting the operation mode	Selecting the Network operation mode	53
Setting the operation commands	Commanding the forward rotation and middle speed signals	54
Setting the monitoring function	Monitoring the output frequency	54
Reading a parameter value	Reading the value of Pr.7 Acceleration time	54
Writing a parameter value	Setting 3.0 seconds in Pr.7 Acceleration time	55
Frequency setting (speed setting)	Setting to 50.00 Hz	55
Reading the fault records	Reading the inverter faults	56
Inverter reset	Resetting the inverter when an inverter error occurs	57

- System configuration for programming example

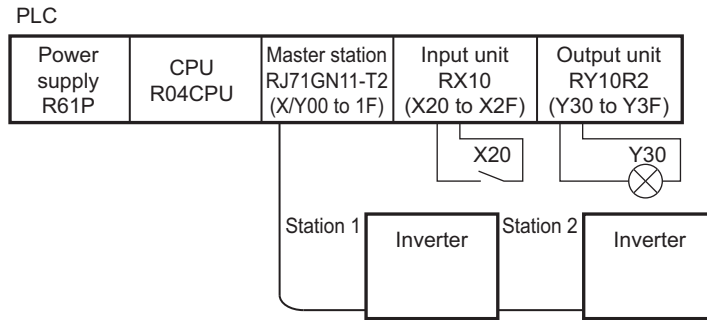

- Setting network parameters of the master station
In the programming example, network parameters are set as follows.

Item	Setting condition
Station type	CC-Link IE TSN (master station)
Start I/O	0000
Network number setting	1
Quantity	2
Network configuration	Refer to the following.
Refresh setting	Refer to the following.

- Network configuration (assignment method: start/end)

Item	Setting condition	
	Module 1	Module 2
Station number	1	2
Station type	Remote station	Remote station
RX/RX setting	Start	0000
	End	001F
RWw/RWr setting	Start	0000
	End	001F
Reserved station / error invalid station	No setting	No setting

- Refresh settings (assignment method: start/end)

Link side			Master side		
Device name	Start	End	Device name	Start	End
SB	0000	013F	SB	0000	013F
SW	0000	013F	SW	0000	013F
RX	0000	003F	X	1000	103F
RY	0000	003F	Y	1000	103F
RWr	0000	003F	W	000000	00003F
RWw	0000	003F	W	000100	00013F

■ Schematic diagrams of remote I/O and remote register devices

- Remote I/O (RX and RY) transmitted between the programmable controller CPU and remote stations

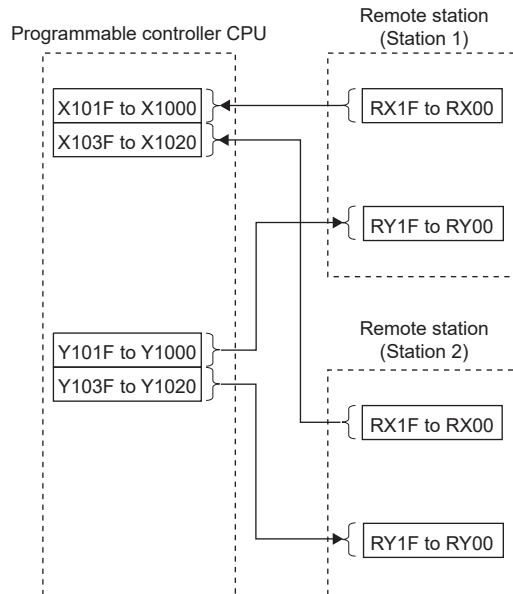

- Remote register areas (RWw and RWr) transmitted between the programmable controller CPU and the remote stations

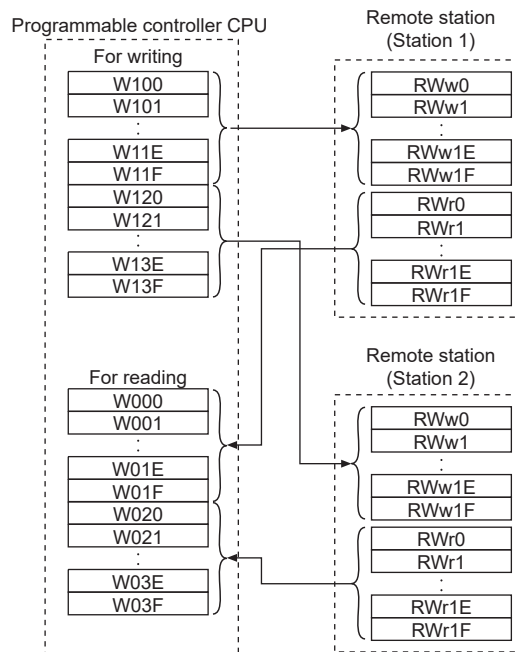

■ Programming example for reading the inverter status

The following program turns ON the signal Y00 of the output unit when the station 1 inverter starts running.

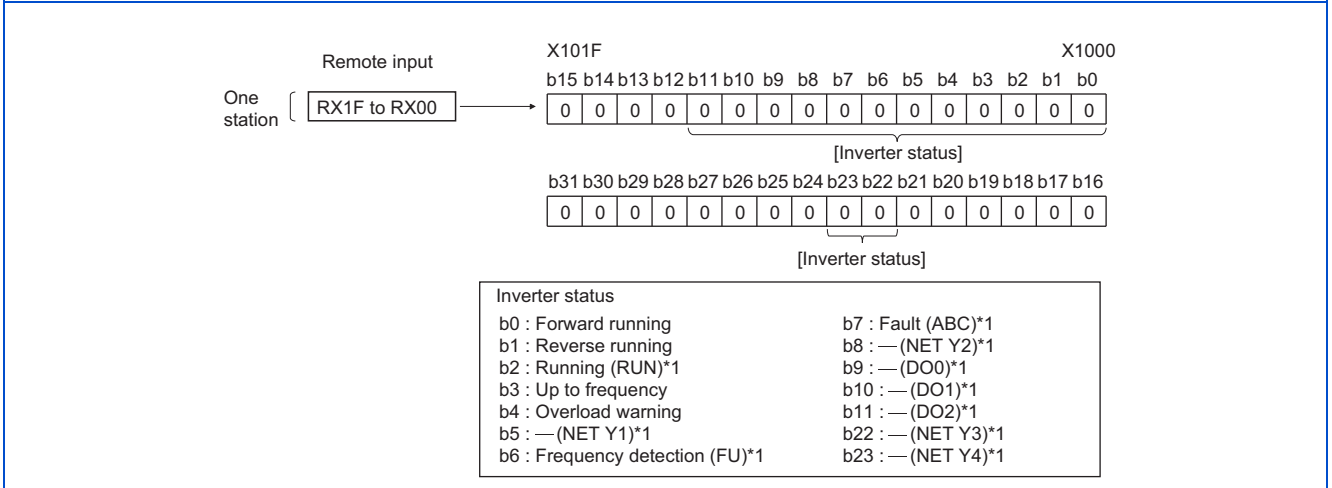
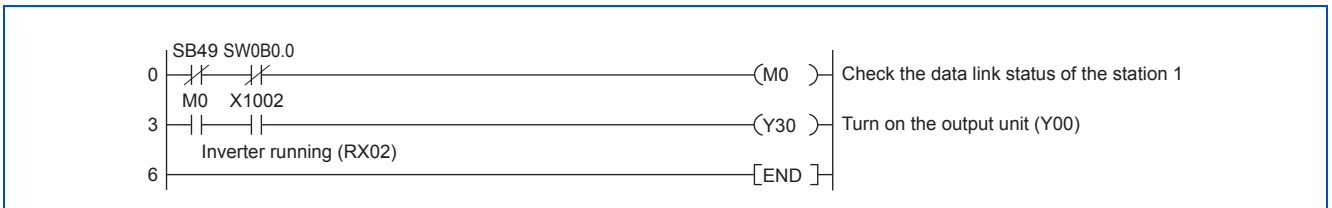

*1 These signals are assigned in the initial status. Use **Pr.190 to Pr.196** and **Pr.313 to Pr.315 (Output terminal function selection)** to change the output signals.

■ Programming example for setting the operation mode

The following explains a program to write various data to the inverter.

The following program changes the operation mode of the station 1 inverter to network operation.

- Operation mode write code: HFB (hexadecimal)
- Network operation set data: H0000 (hexadecimal) (Refer to [page 40](#).)
- The reply code to the instruction code execution is set in D2. (Refer to [page 40](#) for the reply code (RW10).)

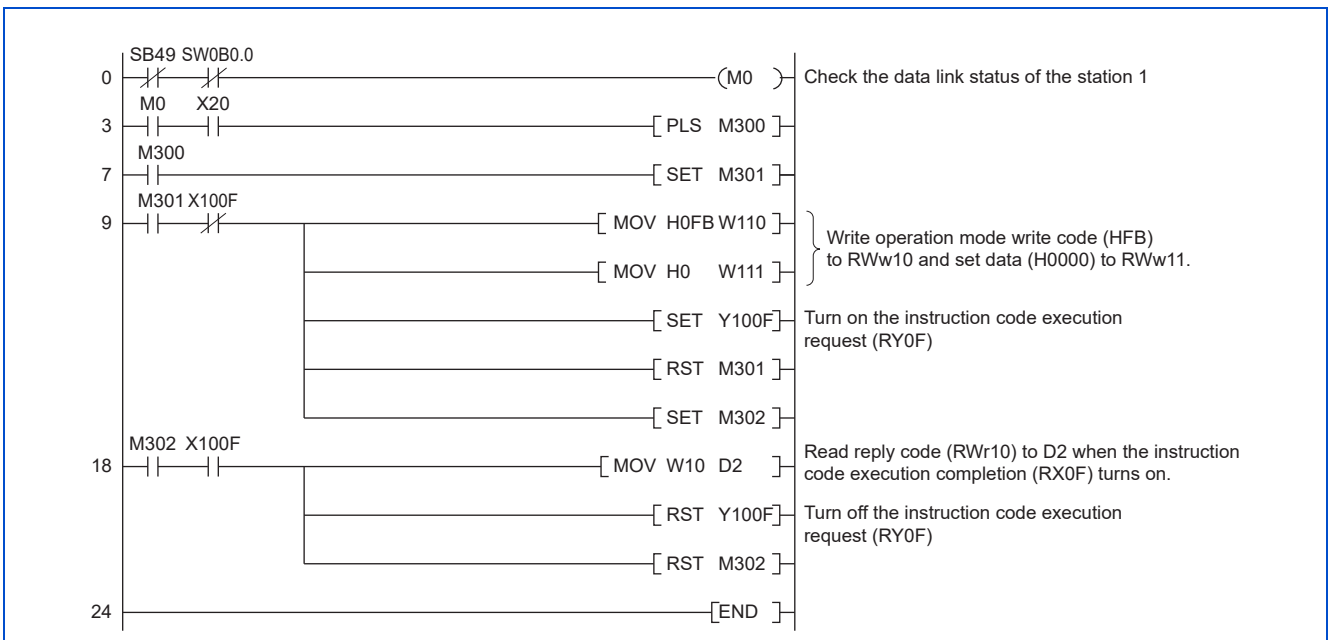

■ Programming example for setting the operation commands

The following program gives a forward rotation command and middle-speed operation command to the station 1 inverter.

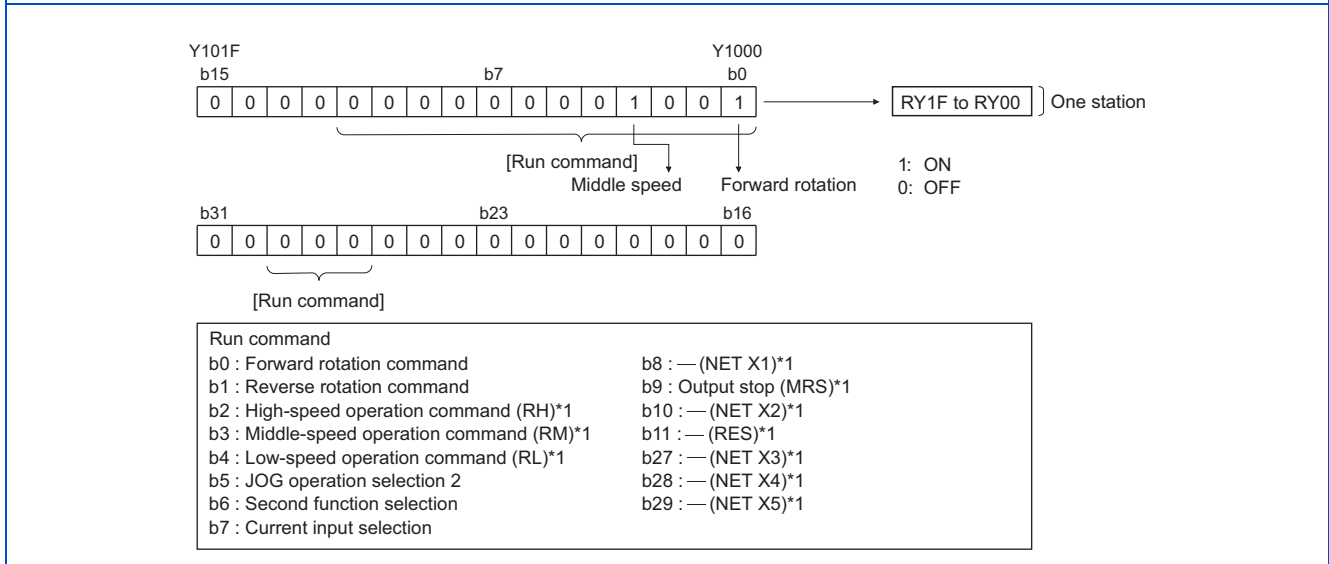
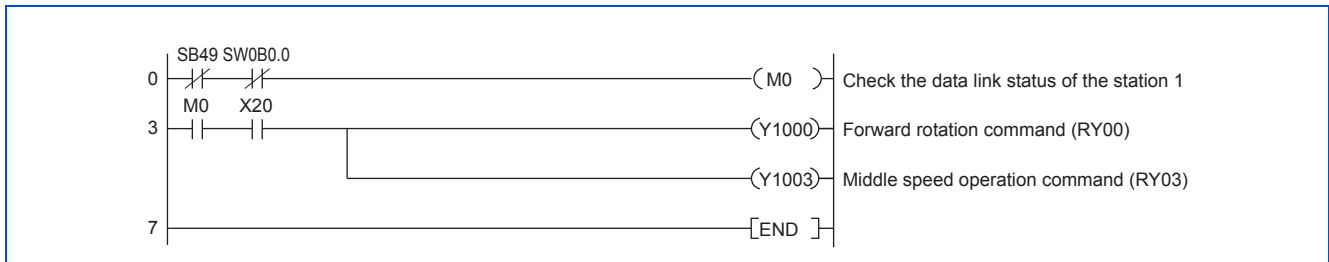

*1 These signals are assigned in the initial status. Use **Pr.180 to Pr.189 (Input terminal function selection)** to change the input signals. Some signals are not controllable by a command from the programmable controller depending on the setting. (For details, refer to the Instruction Manual (Function).)

■ Programming example for monitoring the output frequency

The following explains a program to read monitor functions of the inverter.

The following program reads the output frequency of the station 1 inverter to output to D1.

Output frequency read code: H0001 (hexadecimal)

For the monitor codes, refer to [page 42](#).

Example) The output frequency of 60 Hz is indicated as "H1770 (6000)".

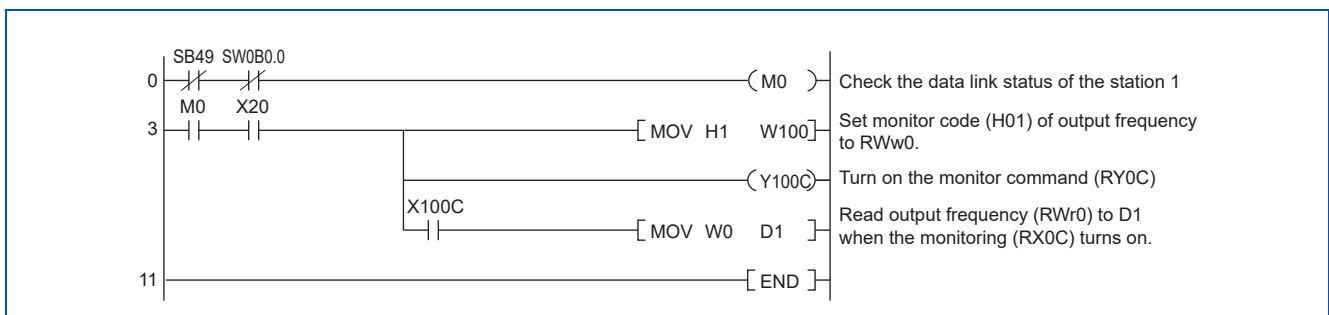

■ Programming example for the parameter reading

The following program reads **Pr.7 Acceleration time** of the station 1 inverter to output to D1.

- **Pr.7 Acceleration time** reading instruction code: H07 (hexadecimal)
- For the instruction codes of parameters, refer to the Instruction Manual (Function).

- The reply code to the instruction code execution is set in D2. (Refer to [page 40](#) for the reply code (RWr10).)

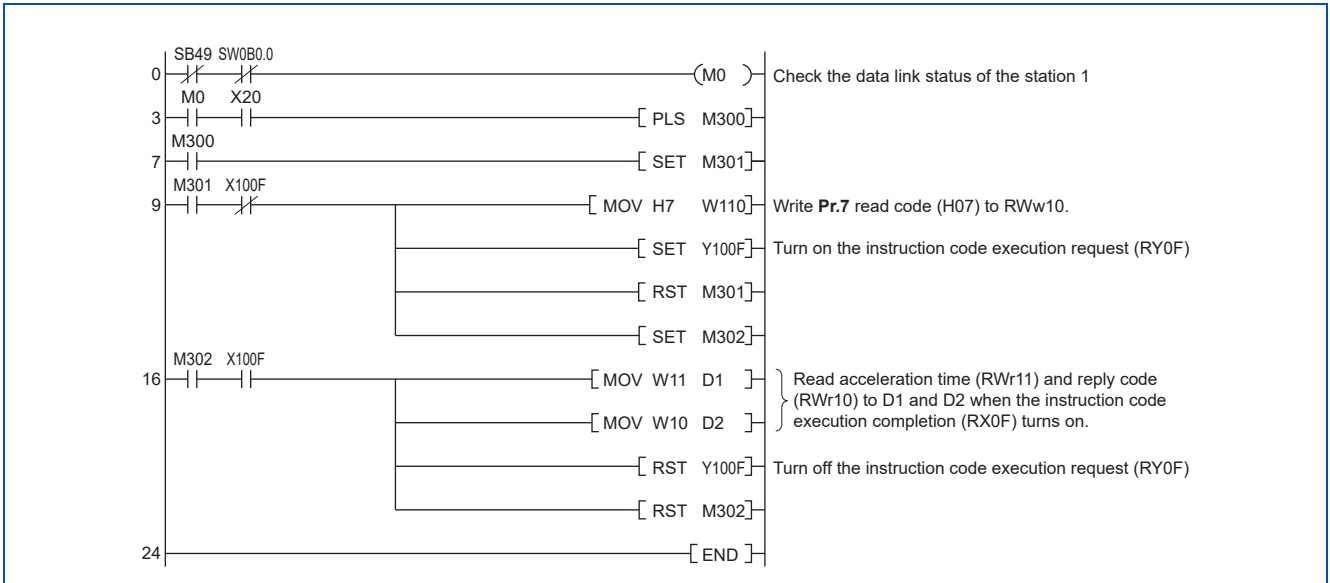

NOTE

- For the parameter assigned the number of 100 or higher, change the link parameter extended setting (set it to the one other than H00). For the setting values, refer to the instruction code list of the Instruction Manual (Function).

■ Programming example for the parameter writing

The following program changes the setting value in **Pr.7 Acceleration time** of the station 1 inverter to 3.0 seconds.

- Acceleration time writing instruction code: H87 (hexadecimal)
- Acceleration time setting data: K30 (decimal)

For the instruction codes of parameters, refer to the Instruction Manual (Function).

The reply code to the instruction code execution is set in D2. (Refer to [page 40](#) for the reply code (RWr10).)

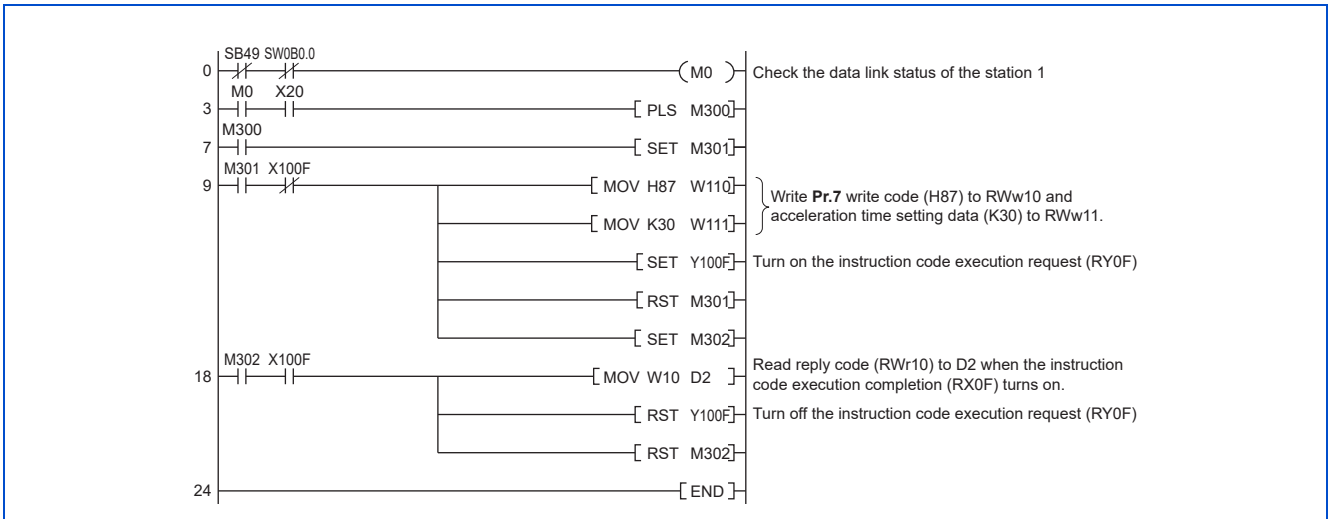

NOTE

- For the parameter assigned the number of 100 or higher, change the link parameter extended setting (set it to the one other than H00). For the setting values, refer to the instruction code list of the Instruction Manual (Function).
- For other functions, refer to the instruction codes (refer to [page 40](#)).

■ Programming example for frequency setting

The following program changes the frequency setting of the station 1 inverter to 50.00 Hz.

- Set frequency: K5000 (decimal)

- The reply code to the instruction code execution is set in D2. (Refer to [page 40](#) for the reply code (RWr2).)

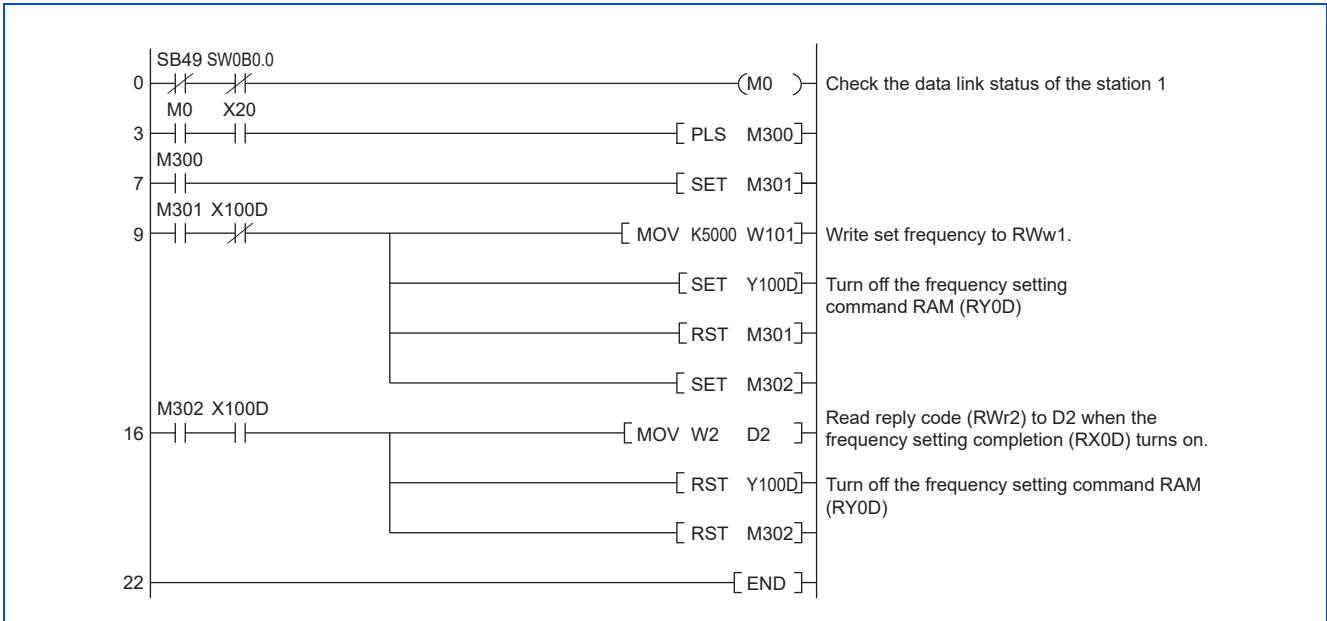

NOTE

- To change the set frequency continuously from a programmable controller, check that the frequency setting complete (for example, X100D) turns ON, and the reply code from the remote register is H0000. Then change the setting data (for example, W101) continuously.
- To write the set frequency to the EEPROM, change the following points in the program shown above.
 - Frequency setting command (from Y100D to Y100E)
 - Frequency setting completion (from X100D to X100E)

<Timing chart when writing to RAM>

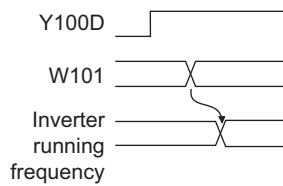

<Timing chart when writing to EEPROM>

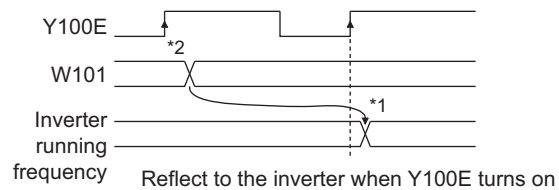

*1 To the EEPROM, a writing is performed only once after the command Y100E turns ON.
 *2 If the set data is changed at the command Y100E ON, the change is not applied to the inverter.

■ Programming example for the fault record reading

The following program reads the fault records of the station 1 inverter to output to D1.

- Fault history No. 1 and 2 reading instruction code: H74 (hexadecimal)

For the error codes, refer to the Instruction Manual (Maintenance).

The reply code to the instruction code execution is set in D2. (Refer to [page 40](#) for the reply code (RWr10).)

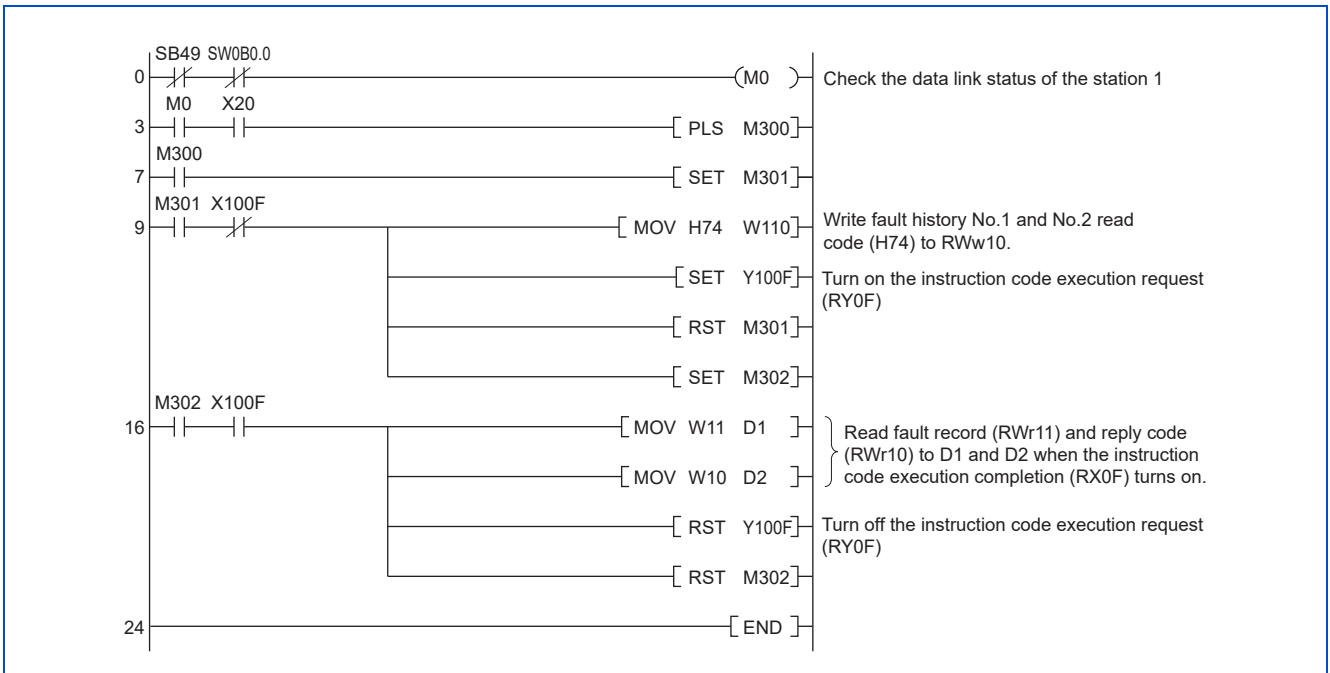

■ Programming example for resetting the inverter at an inverter fault

The following program resets the station 1 inverter at an inverter fault.

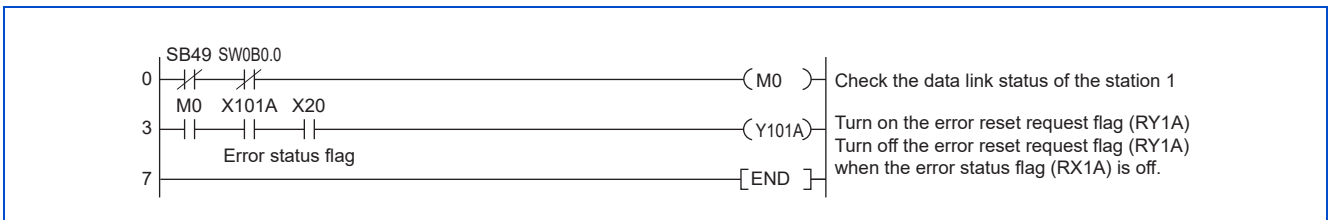

NOTE

- The inverter reset with the flag RY1A shown above is enabled at an inverter fault only.
- When **Pr.349 Communication reset selection** = "0", inverter reset is available independently of the operation mode.
- When using the instruction code execution request (RY0F) with the instruction code (HFD) and data (H9696) to reset the inverter, set a value other than "0" in **Pr.340 Communication startup mode selection** or change the operation mode to the Network operation mode. (For the program example, refer to [page 53](#).)
- Refer to [page 287](#) for operation conditions of inverter reset.

◆ Instructions

■ Programming instructions

- Since the buffer memory data of the master station is kept transferred (refreshed) to/from the inverters, the TO instruction need not be executed every scan in response to data write or read requests. The execution of the TO instruction every scan does not pose any problem.
- If the FROM/TO instruction is executed frequently, data may not be written reliably. When transferring data between the inverter and sequence program via the buffer memory, perform the handshake to confirm that data has been written without error.

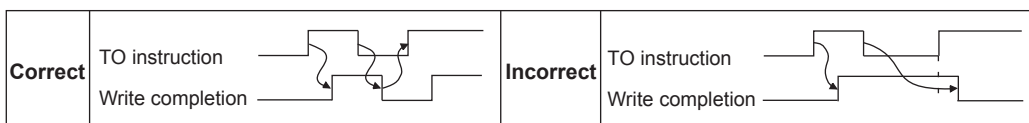

■ Operating and handling instructions

- The commands only from the programmable controller can be accepted during CC-Link IE TSN communication. Operation commands input from external devices are ignored.

- If multiple inverters have the same station number, the communication cannot be performed properly.
- If the programmable controller (master station) is reset during operation through the CC-Link IE TSN or if the programmable controller is powered off, data communication stops and the inverter protective function (E.EHR) is activated. To reset the programmable controller (master station), switch the operation mode to the External operation once, then reset the programmable controller.
- When **Pr.340** = "0", any inverter whose main power is restored is reset to return to the External operation mode. To resume the Network operation, therefore, set the operation mode to the Network operation using the sequence program. Set a value other than "0" in **Pr.340** to start in the Network operation mode after inverter reset. (For details of **Pr.340**, refer to the FR-E800 Instruction Manual (Function).)

■ Troubleshooting

Description	Point to be checked
Communication is not established.	Check that the communication speed is not set to 10 Mbps.
Operation mode does not switch to the Network operation mode.	Check that the Ethernet cable is installed correctly. (Check for contact fault, break in the cable, etc.)
	Check that the inverter is in the External operation mode.
	Check that the operation mode switching program is running.
Inverter does not start in the Network operation mode.	Check that the operation mode switching program has been written correctly.
	Check that the inverter starting program is running.
	Check that the inverter starting program has been written correctly.
	Check that Pr.338 Communication operation command source is not set to External.

NOTE

- When the power supply of one of the inverters connected in line topology is turned OFF then ON during communication, E.EHR may be activated in the preceding inverter on the same communication. In such a case, stop the communication and turn OFF then ON the power supply of the inverter in which E.EHR is activated.

2.6 CC-Link IE Field Network Basic

2.6.1 Outline



CC-Link IE Field Network Basic is available for the FR-E800-(SC)EPA, FR-E806-SCEPA, FR-E800-(SC)EPB, and FR-E806-SCEPB.

The CC-Link IE Field Network Basic enables CC-Link IE communication using the general-purpose Ethernet-based technology. The CC-Link IE Field Network Basic is suited to small-scale equipment for which high-speed control is not necessary, and can coexist with the standard Ethernet TCP/IP (HTTP, FTP, etc.).

◆ Communication specifications

The communication specification varies depending on the specification of the master.

Item	Description
Communication speed	100 Mbps (10 Mbps is not supported.)
Communication method	UDP
Number of connectable units	Master: 1 Remote: up to 64 stations (16 stations × 4 groups) ^{*2}
Connection cable	Ethernet cable (IEEE 802.3 100BASE-TX compliant cable and ANSI/TIA/EIA-568-B (Category 5) compliant shielded 4-pair branched cable)
Topology	Line, star, or a combination of line and star
Number of occupied stations	One station occupied
Maximum number of links per station	RX 64 (8 bytes)
	RY 64 (8 bytes)
	RWr 32 (64 bytes)
	RWw 32 (64 bytes)
Reference response time ^{*1}	Within 15 ms

*1 The reference response time is the period from when the inverter receives a command from the master until the inverter returns the response to the master.

*2 The specification differs depending on the date of manufacture of the inverter. Refer to [page 290](#) and check the SERIAL number.

NOTE

- To use the CC-Link IE Field Network Basic, do not install the FR-A8NC E kit to the inverter. (Doing so disables communication through the CC-Link IE Field Network Basic.)

2.6.2 CC-Link IE Field Network Basic configuration

◆ Procedure

The following shows the procedure to connect the inverter with a Mitsubishi Electric master device.

■ Before communication

1. Connect each unit with an Ethernet cable. (Refer to [page 15](#).)
2. Enter the IP address (**Pr.1434 to Pr.1437**). (Refer to [page 18](#).)
3. Set "61450" (CC-Link IE Field Network Basic) in any of **Pr.1427 to Pr.1430 Ethernet function selection 1 to 4**. (Refer to [page 62](#).)

(Example: **Pr.1429** = "45238" (CC-Link IE TSN) (initial value) → "61450" (CC-Link IE Field Network Basic))

When **Pr.1429** = "45238 (initial value)" (CC-Link IE TSN), change the value to "61450" (CC-Link IE Filed Network Basic). When "45238" is set in any of **Pr.1427 to Pr.1430**, the priority is given to CC-Link IE TSN, disabling CC-Link IE Field Network Basic.

4. Reset the inverter, or turn OFF and then ON the power.

■ Registering a profile

1. Start the engineering software (GX Works3).
2. On the menu bar, select [Tool] > [Profile Management] > [Register...].
3. Select a CSP+ file to be registered on the "Register Profile" screen, and click the [Register] button.

NOTE

- A profile is a compressed file (such as *.zip, *.ipar, and *.cspp). Register a profile without decompressing the file.
- Profile registration is not required for the next time onwards.
- To use GX Works2, refer to "6.1.4 Setting the station information in the CC-Link IEF Basic configuration window" in GX Works2 Version 1 Operating Manual (Common) (SH-080779ENG).

■ Creating a project file

1. For information on creating and opening a project, go to [Help] > [GX Works3 Help].

■ Detecting an Inverter

Detection is not possible when the data link is not established with the master module. For details, refer to the Master Module User's Manual.

1. In the "Navigation" window, select [Parameter] > [Module Parameter].

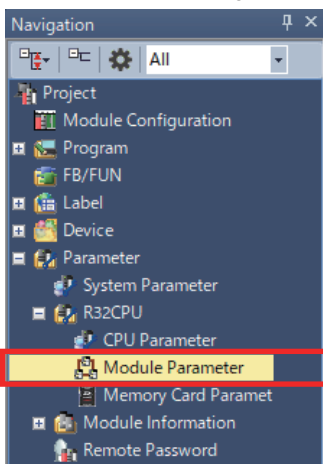

2. Select [Basic Settings] in the "Setting Item List" window.

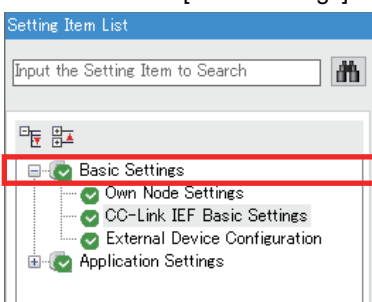

3. In the "CC-Link IEF Basic Configuration" window, go to [Network Configuration Settings] then click  next to the [Detailed Setting] field.

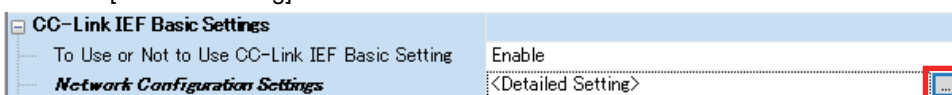

4. In the "CC-Link IEF Basic Configuration" window, click [Detect Now].

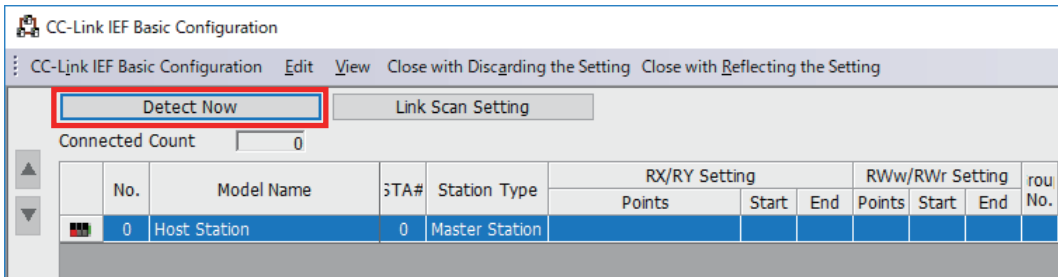

5. Check the "MELSOFT GX Works3" dialog, and click [Yes].

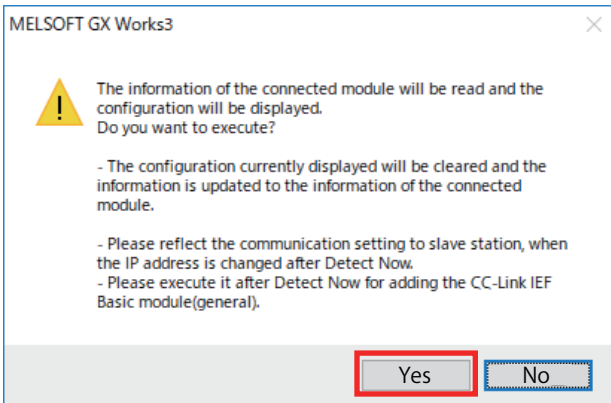

6. The inverter model will appear on the screen when it is detected. (FR-E800-E inverters are displayed in the following example.) Click [Close with Reflecting the Setting] to close the window.

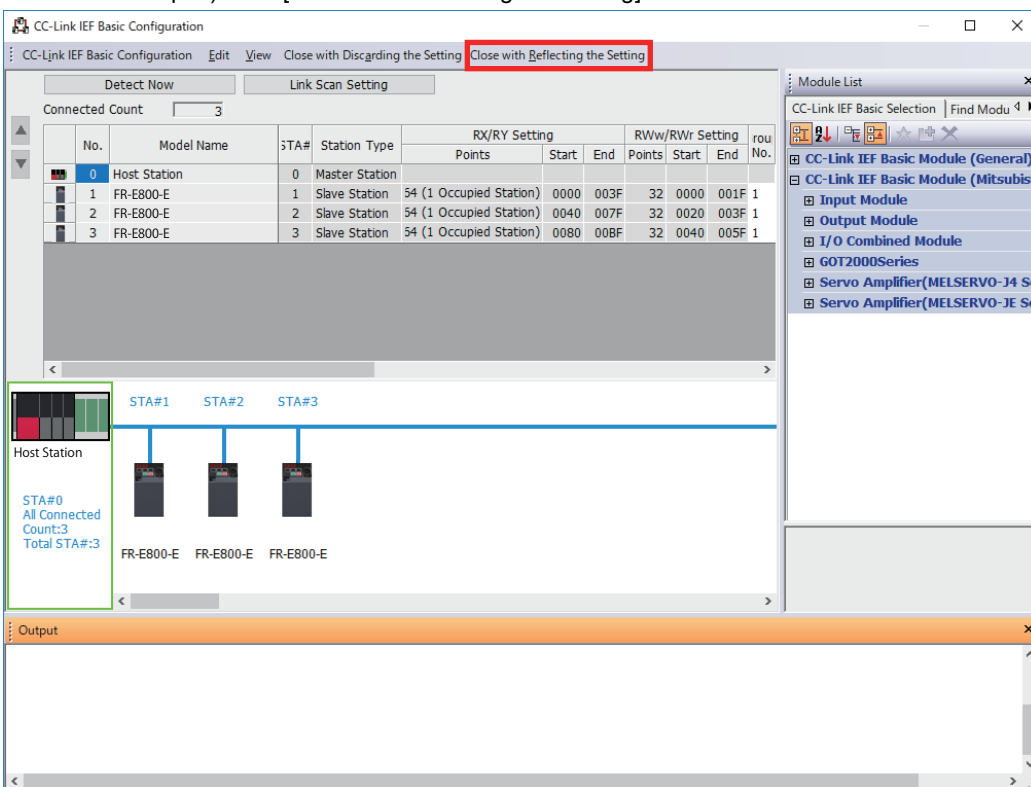

■ Checking communication

The following table shows the status of the LEDs when communication is established between the programmable controller and the inverter. Check the "CC-Link IEF Basic Diagnostics" window to confirm that the communication is established between them.

NS	MS	LINK1	LINK2
OFF	Solid green	Blinking green ^{*1}	

*1 The LED on either LINK1 or LINK2 will blink depending on the port (port 1 or 2) the Ethernet cable is connected to.

NOTE

- If the inverter cannot be detected, on the menu bar select [Diagnostics (D)] > [CC Link IEF Basic Diagnostics]. The "CC Link IEF Basic Diagnostics" window will be displayed. The network status or fault records can be checked.

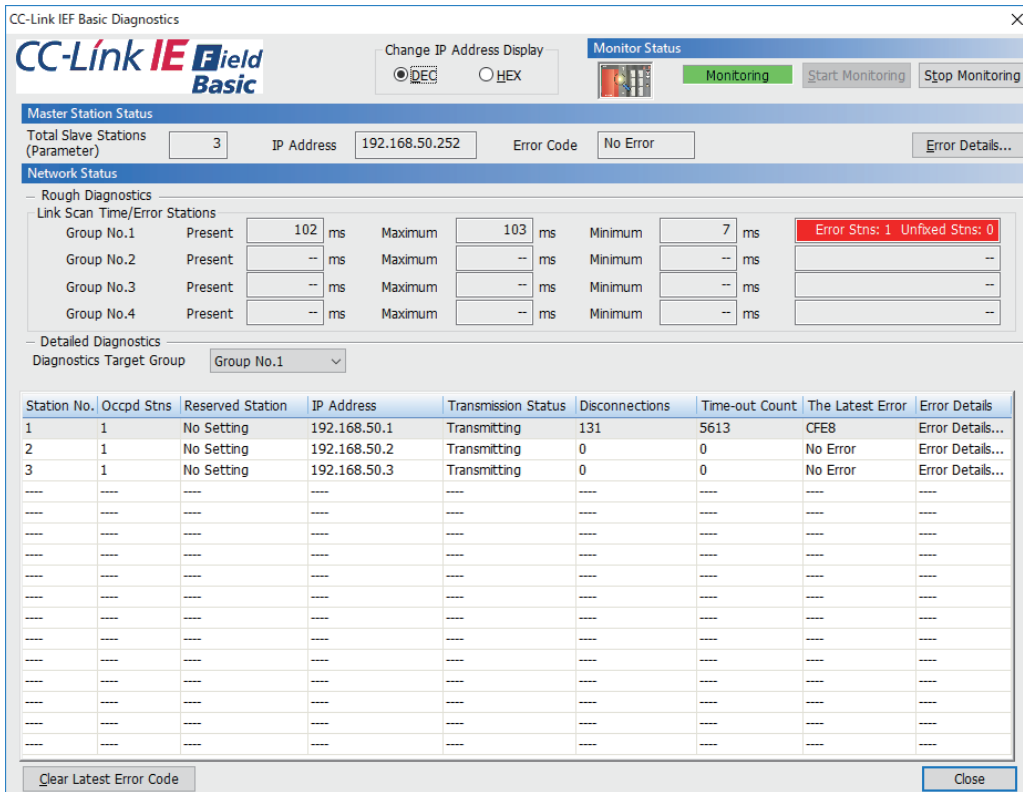

2.6.3 Initial setting for CC-Link IE Field Network Basic

Use the following parameters to perform required settings for Ethernet communication between the inverter and other devices. To make communication between other devices and the inverter, perform the initial settings of the inverter parameters to match the communication specifications of the devices. Data communication cannot be made if the initial settings are not configured or if there is any setting error.

Pr.	Name	Initial value	Setting range	Description
1427 N630 ^{*1}	Ethernet function selection 1	5001	502, 5000 to 5002, 5006 to 5008, 5010 to 5013, 9999, 34962 ^{*3} , 44818 ^{*2} , 45237, 45238, 47808 ^{*2} , 61450	Set the application, protocol, etc.
1428 N631 ^{*1}	Ethernet function selection 2	45237		
1429 N632 ^{*1}	Ethernet function selection 3	45238		
1430 N633 ^{*1}	Ethernet function selection 4	9999		
1432 N644	Ethernet communication check time interval	1.5 s	0	Ethernet communication is available, but the inverter output is shut off in the NET operation mode.
			0.1 to 999.8 s	Set the interval of the communication check (signal loss detection) time for all devices with IP addresses in the range specified for Ethernet command source selection (Pr.1449 to Pr.1454). If a no-communication state persists for longer than the permissible time, the inverter output will be shut off.
			9999	No communication check (signal loss detection)

Pr.	Name	Initial value	Setting range	Description
1449 N670 ^{*1}	Ethernet command source selection IP address 1	0	0 to 255	To limit the network devices that send the operation or speed command through the Ethernet network, set the range of IP addresses of the devices. When Pr.1449 to Pr.1452 = "0 (initial value)", no IP address is specified for command source selection via Ethernet. In this case, operation commands cannot be sent via Ethernet.
1450 N671 ^{*1}	Ethernet command source selection IP address 2	0		
1451 N672 ^{*1}	Ethernet command source selection IP address 3	0		
1452 N673 ^{*1}	Ethernet command source selection IP address 4	0		
1453 N674 ^{*1}	Ethernet command source selection IP address 3 range specification	9999	0 to 255, 9999	
1454 N675 ^{*1}	Ethernet command source selection IP address 4 range specification	9999		

*1 The setting is applied after an inverter reset or next power-ON.

*2 The setting is available for the FR-E800-(SC)EPA and FR-E806-SCEPA.

*3 The setting is available for the FR-E800-(SC)EPB and FR-E806-SCEPB.

NOTE

- The monitor items and parameter settings can be read during communication with the **Pr.1432 Ethernet communication check time interval** = "0 (initial value)" setting, but such operation will become faulty once the operation mode is changed to the NET operation mode. When the NET operation mode is selected as the start-up operation mode, communication is performed once, then an Ethernet communication fault (E.EHR) occurs.
To perform operation or parameter writing via communication, set **Pr.1432** to "9999" or a value larger than the communication cycle or retry time setting. (Refer to [page 64](#).)
- When the CC-Link IE Field Network Basic is used, a communication error (E.EHR) occurs regardless of the **Pr.1432 Ethernet communication check time interval** setting in the following cases: the data addressed to the own station is not received for the predetermined timeout period or longer, or the status bit of the cyclic transmission addressed to the own station turns OFF (when the master inverter gives a command to stop the cyclic transmission). (For the details of the timeout period, status bit of the cyclic transmission, and command to stop the cyclic transmission, refer to the User's Manual of the master device which supports the CC-Link IE Field Network Basic.)

◆ Ethernet function selection (Pr.1427 to Pr.1430)

To select the CC-Link IE Field Network Basic for the application, set "61450" (CC-Link IE Field Network Basic) in any parameter from **Pr.1427 to Pr.1430 Ethernet function selection 1 to 4**. When **Pr.1429** = "45238 (initial value)" (CC-Link IE TSN), change the value to "61450" (CC-Link IE Filed Network Basic). When "45238" is set in any of **Pr.1427 to Pr.1430**, the priority is given to CC-Link IE TSN, disabling CC-Link IE Field Network Basic.

NOTE

- Change the setting if selected communication protocols cannot be used together. (Refer to [page 7](#) and [page 226](#).)

◆ Ethernet IP address for command source selection (Pr.1449 to Pr.1454)

- To limit the network devices that send the operation or speed command through the Ethernet network, set the range of IP addresses of the devices.
- When **Pr.1449 to Pr.1452** = "0 (initial value)", no IP address is specified for command source selection via Ethernet. In this case, operation commands cannot be sent via Ethernet.

- The setting range for command source selection depends on the settings in **Pr.1451** and **Pr.1453**, and **Pr.1452** and **Pr.1454**. (Either of the settings can be larger than the other in **Pr.1451** and **Pr.1453**, and **Pr.1452** and **Pr.1454**.)

**[Setting example 1]
Configuration**

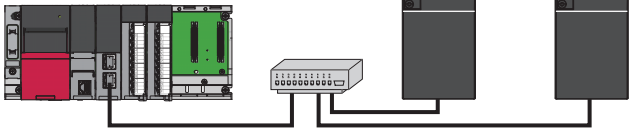

Master station	Remote station 1	Remote station 2
iQ-R R08CPU	FR-E800	FR-E800
192.168.50.100	192.168.50.1	192.168.50.2

To allow the master station to control the remote stations, set the parameters in remote stations 1 and 2 as follows to specify the IP address range for Ethernet command source selection.

Set the IP address of the master station in the engineering software (GX Works3) within the range from 192.168.50.100 to 192.168.50.110.

	Pr.1449	Pr.1450	Pr.1451	Pr.1452
Ethernet IP address for command source selection	192	168	50	100
			Pr.1453	Pr.1454
Command source selection range setting for the Ethernet IP address	—	—	9999	110

The range is between the values set in both parameters.

In this case, the IP address range in which Ethernet communication is permitted is "192.168.50.xxx (100 to 110)".

[Setting example 2]

	Pr.1449	Pr.1450	Pr.1451	Pr.1452
Ethernet IP address for command source selection	192	168	1	100
			Pr.1453	Pr.1454
Command source selection range setting for the Ethernet IP address	—	—	3	150

The range is between the values set in both parameters.

The range is between the values set in both parameters.

In this case, the IP address range for command source selection via Ethernet communication is "192.168.x (1 to 3).xxx (100 to 150)".

- When "9999 (initial value)" is set in **Pr.1453** or **Pr.1454**, the range is invalid.

◆ Ethernet communication check time interval (Pr.1432)

- If a signal loss (communication stop) is detected between the inverter and all the devices with IP addresses in the range for Ethernet command source selection (**Pr.1449 to Pr.1454**) as a result of a signal loss detection, a communication error (E.EHR) occurs and the inverter output will be shut off.
- When "9999" is set in **Pr.1432**, the communication check (signal loss detection) will not be performed.
- The monitor items and parameter settings can be read via Ethernet when "0" is set in **Pr.1432**, but a communication error (E.EHR) occurs instantly when the operation mode is switched to the Network operation.
- A signal loss detection is made when any of 0.1 s to 999.8 s is set in **Pr.1432**. In order to enable the signal loss detection, data must be sent by connected devices at an interval equal to or less than the time set for the communication check. (The inverter makes a communication check (clearing of communication check counter) regardless of the station number setting of the data sent from the master).

- Communication check is started at the first communication when the inverter operates in the Network operation mode and the command source is specified as communication via the Ethernet connector.

Example) When Pr.1432 = 0.1 to 999.8 s

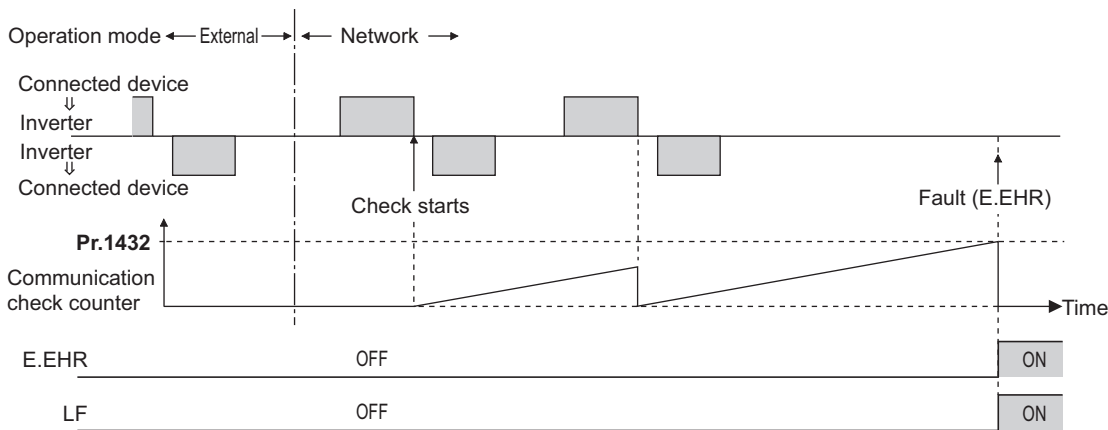

2.6.4 Parameters related to CC-Link IE Field Network Basic

The following parameters are used for CC-Link IE Field Network Basic communication. Set the parameters as required.

Pr.	Name	Initial value	Setting range	Description
541 N100	Frequency command sign selection	0	0 1	Signed frequency command value Unsigned frequency command value
544 N103 ^{*1}	CC-Link extended setting	0	0, 1, 12, 14, 18, 38, 100, 112, 114, 118, 138	The function of the remote registers can be extended when the CC-Link IE Field Network Basic is used.
1426 N641 ^{*1}	Link speed and duplex mode selection	0	0 to 4	Set the communication speed and the communication mode (full-duplex/half-duplex).
1442 N660 ^{*1}	IP filter address 1 (Ethernet)	0	0 to 255	Set the range of connectable IP addresses for the network devices. (When Pr.1442 to Pr.1445 = "0 (initial value)", the function is invalid.)
1443 N661 ^{*1}	IP filter address 2 (Ethernet)	0		
1444 N662 ^{*1}	IP filter address 3 (Ethernet)	0		
1445 N663 ^{*1}	IP filter address 4 (Ethernet)	0		
1446 N664 ^{*1}	IP filter address 2 range specification (Ethernet)	9999	0 to 255, 9999	
1447 N665 ^{*1}	IP filter address 3 range specification (Ethernet)	9999		
1448 N666 ^{*1}	IP filter address 4 range specification (Ethernet)	9999		
804 D400	Torque command source selection	0	0, 1, 3 to 6	
810 H700	Torque limit input method selection	0	0 to 2	The torque limit input method can be selected.

*1 The setting is applied after an inverter reset or next power-ON.

◆ CC-Link extended setting (Pr.544)

- Use this parameter to select the function of the remote registers for the CC-Link IE Field Network Basic.

Pr.544 setting	Description	Refer to page
0 (initial value)	Compatible with CC-Link Ver.1	66
1	Compatible with CC-Link Ver.1	67
12	Compatible with the double setting of CC-Link Ver.2	68
14	Compatible with the quadruple setting of CC-Link Ver.2	68
18, 38	Compatible with the octuple setting of CC-Link Ver.2	69

Pr.544 setting	Description	Refer to page
100	Compatible with CC-Link Ver.1	PLC function —*1
112	Compatible with the double setting of CC-Link Ver.2	
114	Compatible with the quadruple setting of CC-Link Ver.2	
118, 138	Compatible with the octuple setting of CC-Link Ver.2	

*1 Refer to the PLC Function Programming Manual.

◆ Frequency command with sign (Pr.541)

- The start command (forward/reverse rotation) can be inverted by adding a plus or minus sign to the value of the frequency command sent through the CC-Link IE Field Network Basic.
- The **Pr.541 Frequency command sign selection** setting is applied to the frequency command from RWw1. (Refer to page 72.)

Rotations per minute (machine speed) setting using Pr.37 and Pr.53	Pr.541 setting	Sign	Setting range	Actual frequency command
Disabled	0	Without	0 to 59000	0 to 590.00 Hz
	1	With	-32768 to 32767 (two's complement)	-327.68 to 327.67 Hz
Enabled	0	Without	0 to 65535	The rotation speed command or the machine speed command is selected depending on the Pr.37 and Pr.53 settings. (1 increments)
	1	With	-32768 to 32767 (two's complement)	

- Relationship between the start command and sign (**Pr.541** = "1")

Start command	Sign of the frequency command	Actual operation command
Forward rotation	+	Forward rotation
	-	Reverse rotation
Reverse rotation	+	Reverse rotation
	-	Forward rotation

NOTE

- When **Pr.541** = "1" (with sign)
 - When EEPROM write is specified by turning ON of RYE, write mode error (error code H01) will occur.
 - When both RYD and RYE are turned ON while both of them are enabled (**Pr.544** ≠ "0"), RYD has precedence.
 - When power is turned ON (inverter reset), the initial setting status of the sign bit is "positive" and the set frequency is 0 Hz. (The motor does not operate at the frequency set before turning OFF the power (inverter reset).)
 - When set frequency is written with the instruction code of HED or HEE, the sign of the frequency command is not changed.

◆ I/O signal list

■ When Pr.544 = "0" (compatible with CC-Link Ver.1)

- Remote I/O signals

Device No.*7	Signal	Refer to page	Device No.*7	Signal	Refer to page
RYn0	Forward rotation command*2	70	RXn0	Forward running	71
RYn1	Reverse rotation command*2	70	RXn1	Reverse running	71
RYn2	High-speed operation command (terminal RH function)*1	70	RXn2	Running (terminal RUN function)*3	71
RYn3	Middle-speed operation command (terminal RM function)*1	70	RXn3	Up to frequency*2	71
RYn4	Low-speed operation command (terminal RL function)*1	70	RXn4	Overload warning*2	71
RYn5	JOG operation selection 2*2	70	RXn5	Pr.193 assignment function (NET Y1)*6	71
RYn6	Second function selection*2	70	RXn6	Frequency detection (terminal FU function)*3	71
RYn7	Current input selection*2	70	RXn7	Fault (terminal ABC function)*3	71
RYn8	Pr.185 assignment function (NET X1)*5	70	RXn8	Pr.194 assignment function (NET Y2)*6	71
RYn9	Output stop (terminal MRS function)*1	70	RXn9	Pr.313 assignment function (DO0)*4	71

Device No. ^{*7}	Signal	Refer to page	Device No. ^{*7}	Signal	Refer to page
RYnA	Pr.186 assignment function (NET X2) ^{*5}	70	RXnA	Pr.314 assignment function (DO1) ^{*4}	71
RYnB	Pr.184 assignment function (RES) ^{*5}	70	RXnB	Pr.315 assignment function (DO2) ^{*4}	71
RYnC	Monitor command	70	RXnC	Monitoring	71
RYnD	Frequency setting command (RAM)	70	RXnD	Frequency setting completion (RAM)	71
RYnE	Frequency setting command (RAM, EEPROM)	70	RXnE	Frequency setting completion (RAM, EEPROM)	71
RYnF	Instruction code execution request	70	RXnF	Instruction code execution completed	71
RY(n+1)0 to RY(n+1)7	Reserved	—	RX(n+1)0 to RX(n+1)5	Reserved	—
RY(n+1)8	Not used (initial data process completion flag)	—	RX(n+1)6	Pr.195 assignment function (NET Y3) ^{*6}	71
RY(n+1)9	Not used (initial data process request flag)	—	RX(n+1)7	Pr.196 assignment function (NET Y4) ^{*6}	71
RY(n+1)A	Error reset request flag	70	RX(n+1)8	Not used (initial data process request flag)	—
RY(n+1)B	Pr.187 assignment function (NET X3) ^{*5}	70	RX(n+1)9	Not used (initial data process completion flag)	—
RY(n+1)C	Pr.188 assignment function (NET X4) ^{*5}	70	RX(n+1)A	Error status flag	71
RY(n+1)D	Pr.189 assignment function (NET X5) ^{*5}	70	RX(n+1)B	Remote station ready	71
RY(n+1)E	Reserved	—	RX(n+1)C	In-position ^{*2}	71
RY(n+1)F			RX(n+1)D	During position command operation ^{*2}	71
			RX(n+1)E	Home position return completed ^{*2}	71
			RX(n+1)F	Home position return failure ^{*2}	71

*1 These signals are set in the initial setting. Using Pr.180 to Pr.183, input signals assigned to the device numbers can be changed.

For details of Pr.180 to Pr.183, refer to the FR-E800 Instruction Manual (Function).

*2 The signals are fixed. They cannot be changed using parameters.

*3 These signals are set in the initial setting. Using Pr.190 to Pr.192, output signals assigned to the device numbers can be changed.

For details of Pr.190 to Pr.192, refer to the FR-E800 Instruction Manual (Function).

*4 Output signal can be assigned using Pr.313 to Pr.315.

For details, refer to the description of Pr.313 to Pr.315 (Output terminal function selection) in the FR-E800 Instruction Manual (Function).

*5 Input signals can be assigned using Pr.184 to Pr.189.

For details, refer to the description of Pr.184 to Pr.189 (Input terminal function selection) in the FR-E800 Instruction Manual (Function).

*6 Output signals can be assigned using Pr.193 to Pr.196.

For details, refer to the description of Pr.193 to Pr.196 (Output terminal function selection) in the FR-E800 Instruction Manual (Function).

*7 "n" indicates a value determined by the station number.

- Remote registers

Address ^{*5}	Description		Refer to page	Address ^{*5}	Description	Refer to page
	Upper 8 bits	Lower 8 bits				
RWwn	Monitor code 2	Monitor code 1	71	RWRn	First monitor value ^{*4}	73
RWwn+1	Set frequency (0.01 Hz increments) / torque command ^{*2*3}		72	RWRn+1	Second monitor value ^{*4}	73
RWwn+2	H00 (arbitrary) ^{*1}	Instruction code	72	RWRn+2	Reply code	73
RWwn+3	Data to be written		72	RWRn+3	Data to be read	73

*1 The upper 8 bits always contains H00 even a different value is set.

*2 When Pr.804 = "3 or 5" during torque control under Real sensorless vector control or Vector control, a torque command value is set in RWwn+1.

*3 The display can be changed to rotations per minute (machine speed) using Pr.37 and Pr.53.

*4 When the item displayed in frequency is selected, the Pr.37 and Pr.53 settings are invalid.

*5 "n" indicates a value determined by the station number.

■ When Pr.544 = "1" (compatible with CC-Link Ver.1)

- Remote I/O signals

Settings are the same as those when Pr.544 = "0". (Refer to page 66.)

- Remote registers

Address ^{*4}	Description		Refer to page	Address ^{*4}	Description		Refer to page
	Upper 8 bits	Lower 8 bits			Upper 8 bits	Lower 8 bits	
RWwn	Monitor code 2	Monitor code 1	71	RWRn	First monitor value ^{*3}		73
RWwn+1	Set frequency (0.01 Hz increments) / torque command ^{*1*2}		72	RWRn+1	Second monitor value ^{*3}		73

Address ^{*4}	Description		Refer to page	Address ^{*4}	Description		Refer to page
	Upper 8 bits	Lower 8 bits			Upper 8 bits	Lower 8 bits	
RWwn+2	Link parameter extended setting	Instruction code	72	RWrn+2	Reply code 2	Reply code 1	73
RWwn+3	Data to be written		72	RWrn+3	Data to be read		73

- *1 When **Pr.804** = "3 or 5" during torque control under Real sensorless vector control or Vector control, a torque command value is set in RWwn+1.
- *2 The display can be changed to rotations per minute (machine speed) using **Pr.37 and Pr.53**.
- *3 When the item displayed in frequency is selected, the **Pr.37 and Pr.53** settings are invalid.
- *4 "n" indicates a value determined by the station number.

■ When Pr.544 = "12" (Compatible with the double setting of CC-Link Ver.2)

- Remote I/O signals
Settings are the same as those when **Pr.544** = "0". (Refer to [page 66.](#))
- Remote registers

Address ^{*4}	Description		Refer to page	Address ^{*4}	Description		Refer to page
	Upper 8 bits	Lower 8 bits			Upper 8 bits	Lower 8 bits	
RWwn	Monitor code 2	Monitor code 1	71	RWrn	First monitor value ^{*3}		73
RWwn+1	Set frequency (0.01 Hz increments) / torque command ^{*1*2}		72	RWrn+1	Second monitor value ^{*3}		73
RWwn+2	Link parameter extended setting	Instruction code	72	RWrn+2	Reply code 2	Reply code 1	73
RWwn+3	Data to be written		72	RWrn+3	Data to be read		73
RWwn+4	Monitor code 3		72	RWrn+4	Third monitor value ^{*3}		73
RWwn+5	Monitor code 4		72	RWrn+5	Fourth monitor value ^{*3}		73
RWwn+6	Monitor code 5		72	RWrn+6	Fifth monitor value ^{*3}		73
RWwn+7	Monitor code 6		72	RWrn+7	Sixth monitor value ^{*3}		73

- *1 When **Pr.804** = "3 or 5" during torque control under Real sensorless vector control or Vector control, a torque command value is set in RWwn+1.
- *2 The display can be changed to rotations per minute (machine speed) using **Pr.37 and Pr.53**.
- *3 When the item displayed in frequency is selected, the **Pr.37 and Pr.53** settings are invalid.
- *4 "n" indicates a value determined by the station number.

■ When Pr.544 = "14" (Compatible with the quadruple setting of CC-Link Ver.2)

- Remote I/O signals
Settings are the same as those when **Pr.544** = "0". (Refer to [page 66.](#))
- Remote registers

Address ^{*5}	Description		Refer to page	Address ^{*5}	Description		Refer to page
	Upper 8 bits	Lower 8 bits			Upper 8 bits	Lower 8 bits	
RWwn	Monitor code 2	Monitor code 1	71	RWrn	First monitor value ^{*3}		73
RWwn+1	Set frequency (0.01 Hz increments) ^{*2}		72	RWrn+1	Second monitor value ^{*3}		73
RWwn+2	Link parameter extended setting	Instruction code	72	RWrn+2	Reply code 2	Reply code 1	73
RWwn+3	Data to be written		72	RWrn+3	Data to be read		73
RWwn+4	Monitor code 3		72	RWrn+4	Third monitor value ^{*3}		73
RWwn+5	Monitor code 4		72	RWrn+5	Fourth monitor value ^{*3}		73
RWwn+6	Monitor code 5		72	RWrn+6	Fifth monitor value ^{*3}		73
RWwn+7	Monitor code 6		72	RWrn+7	Sixth monitor value ^{*3}		73
RWwn+8	Fault record No.	H00	72	RWrn+8	Fault record No.	Fault record (fault data)	73
RWwn+9	PID set point (0.01% increments) ^{*1}		72	RWrn+9	Fault record (output frequency) ^{*4}		73
RWwn+A	PID measured value (0.01% increments) ^{*1}		72	RWrn+A	Fault record (output current)		73
RWwn+B	PID deviation (0.01% increments) ^{*1}		72	RWrn+B	Fault record (output voltage)		73
RWwn+C	Torque command or torque limit		72, 78	RWrn+C	Fault record (energization time)		73
RWwn+D	H00 (Free)		—	RWrn+D	H00 (Free)		—
RWwn+E							
RWwn+F							

- *1 Validity depends on the **Pr.128, Pr.609, and Pr.610** settings. For details, refer to the FR-E800 Instruction Manual (Function). If the data outside the range is set, the previous setting is retained.
- *2 The display can be changed to rotations per minute (machine speed) using **Pr.37 and Pr.53**.
- *3 When the item displayed in frequency is selected, the **Pr.37 and Pr.53** settings are invalid.

*4 The frequency is always displayed regardless of the settings in **Pr.37 and Pr.53**.

*5 "n" indicates a value determined by the station number.

■ When Pr.544 = "18 or 38" (Compatible with the octuple setting of CC-Link Ver.2)

- Remote I/O signals

Settings are the same as those when **Pr.544** = "0". (Refer to [page 66](#).)

- Remote registers

Address ^{*5}	Description		Refer to page	Address ^{*5}	Description		Refer to page
	Upper 8 bits	Lower 8 bits			Upper 8 bits	Lower 8 bits	
RWwn	Monitor code 2	Monitor code 1	71	RWrn	First monitor value ^{*3}		73
RWwn+1	Set frequency (0.01 Hz increments) ^{*2}		72	RWrn+1	Second monitor value ^{*3}		73
RWwn+2	Link parameter extended setting	Instruction code	72	RWrn+2	Reply code 2	Reply code 1	73
RWwn+3	Data to be written		72	RWrn+3	Data to be read		73
RWwn+4	Monitor code 3		72	RWrn+4	Third monitor value ^{*3}		73
RWwn+5	Monitor code 4		72	RWrn+5	Fourth monitor value ^{*3}		73
RWwn+6	Monitor code 5		72	RWrn+6	Fifth monitor value ^{*3}		73
RWwn+7	Monitor code 6		72	RWrn+7	Sixth monitor value ^{*3}		73
RWwn+8	Fault record No.	H00	72	RWrn+8	Fault record No.	Fault record (fault data)	73
RWwn+9	PID set point (0.01% increments) ^{*1}		72	RWrn+9	Fault record (output frequency) ^{*4}		73
RWwn+A	PID measured value (0.01% increments) ^{*1}		72	RWrn+A	Fault record (output current)		73
RWwn+B	PID deviation (0.01% increments) ^{*1}		72	RWrn+B	Fault record (output voltage)		73
RWwn+C	Torque command or torque limit		72, 78	RWrn+C	Fault record (energization time)		73
RWwn+D	H00 (Free)		—	RWrn+D	H00 (Free)		—
RWwn+E	H00 (Free)						
RWwn+F	H00 (Free)						
RWwn+10	Link parameter extended setting	Instruction code	72	RWrn+10	Reply code		73
RWwn+11	Data to be written		72	RWrn+11	Data to be read		73
RWwn+12	Link parameter extended setting	Instruction code	72	RWrn+12	Reply code		73
RWwn+13	Data to be written		72	RWrn+13	Data to be read		73
RWwn+14	Link parameter extended setting	Instruction code	72	RWrn+14	Reply code		73
RWwn+15	Data to be written		72	RWrn+15	Data to be read		73
RWwn+16	Link parameter extended setting	Instruction code	72	RWrn+16	Reply code		73
RWwn+17	Data to be written		72	RWrn+17	Data to be read		73
RWwn+18	Link parameter extended setting	Instruction code	72	RWrn+18	Reply code		73
RWwn+19	Data to be written		72	RWrn+19	Data to be read		73
RWwn+1A	H00 (Free)		—	RWrn+1A	H00 (Free)		—
RWwn+1B							
RWwn+1C							
RWwn+1D							
RWwn+1E							
RWwn+1F							

*1 Validity depends on the **Pr.128, Pr.609, and Pr.610** settings. For details, refer to the FR-E800 Instruction Manual (Function). If the data outside the range is set, the previous setting is retained.

*2 The display can be changed to rotations per minute (machine speed) using **Pr.37 and Pr.53**.

*3 When the item displayed in frequency is selected, the **Pr.37 and Pr.53** settings are invalid.

*4 The frequency is always displayed regardless of the settings in **Pr.37 and Pr.53**.

*5 "n" indicates a value determined by the station number.

◆ Details of the I/O signals

The device numbers described in this section are for the station number 1. For the station number 2 and later, the device numbers are different. (Refer to the manual for the CC-Link master module for the correspondence between device numbers and station numbers.)

■ Output signals (from the master module to the inverter)

Output signals from the master module are as follows. (Input signals to the inverter)

Device No.	Signal	Description	
RY0	Forward rotation command ^{*2}	0: Stop command 1: Forward rotation start	When "1" is set, a start command is input to the inverter. When "1" is set in RY0 and RY1, a stop command is input.
RY1	Reverse rotation command ^{*2}	0: Stop command 1: Reverse rotation start	
RY2	High-speed operation command (terminal RH function) ^{*1}	Functions assigned to Pr.180 to Pr.182 are activated.	
RY3	Middle-speed operation command (terminal RM function) ^{*1}		
RY4	Low-speed operation command (terminal RL function) ^{*1}		
RY5	JOG operation selection 2 ^{*2}	JOG2 signal	
RY6	Second function selection ^{*2}	RT signal	
RY7	Current input selection ^{*2}	AU signal	
RY8	— (terminal NET X1 function) ^{*3}	The function assigned to Pr.185 is activated.	
RY9	Output stop (terminal MRS function) ^{*1}	The function assigned to Pr.183 is activated.	
RYA	— (terminal NET X2 function) ^{*3}	The function assigned to Pr.186 is activated.	
RYB	— (Function of terminal RES) ^{*3}	The function assigned to Pr.184 is activated.	
RYC	Monitor command	When "1" is set in RYC, the monitored value is set in the remote register RWr0, 1, 4 to 7, and "1" is set in RXC (device for the Monitoring signal). While "1" is set in RYC, the monitored data is always updated.	
RYD ^{*5}	Frequency setting command / torque command (RAM)	When "1" is set in RYD, the set frequency / torque command (RWw1) is written to the RAM of the inverter. ^{*4} After the writing completes, "1" is set in the frequency setting / torque command completion (RXD). Under Real sensorless vector control, Vector control, and PM sensorless vector control, the following value is also written to RAM at the same time. • During torque control ^{*7} : Torque command value • During speed control / position control: Torque limit value	
RYE ^{*5}	Frequency setting command / torque command (RAM, EEPROM)	When "1" is set in RYE, the set frequency / torque command (RWw1) is written to the RAM and EEPROM of the inverter. After the writing completes, "1" is set in the frequency setting / torque command completion (RXE). Under Real sensorless vector control, Vector control, and PM sensorless vector control, the following value is also written to RAM and EEPROM at the same time. • During torque control ^{*7} : Torque command value • During speed control / position control: Torque limit value To change the frequency consecutively, be sure to write data to the RAM of the inverter.	
RYF ^{*5}	Instruction code execution request	At the ON edge of RYF, processing corresponding to the instruction codes set to RWw2, 10, 12, 14, 16, and 18 are executed. "1" is set in the instruction code execution completed (RXF) after completion of instruction codes. When an instruction code execution error occurs, a value other than "0" is set in the reply code (RWr2, 10, 12, 14, 16, or 18).	
RY1A	Error reset request flag	When "1" is set in RY1A at an inverter fault, the inverter is reset, and then "0" is set in the error status flag (RX1A). ^{*6}	
RY1B	— (terminal NET X3 function) ^{*3}	Functions assigned to Pr.187 to Pr.189 are activated.	
RY1C	— (terminal NET X4 function) ^{*3}		
RY1D	— (terminal NET X5 function) ^{*3}		

*1 These signals are set in the initial setting. Using **Pr.180 to Pr.183**, input signals assigned to the device numbers can be changed. Some signals are not controllable via network depending on the settings of **Pr.338 and Pr.339**. For details of **Pr.180 to Pr.183, Pr.338, and Pr.339**, refer to the FR-E800 Instruction Manual (Function).

*2 The signals are fixed. They cannot be changed using parameters.

*3 No signal is assigned in the initial setting. Use **Pr.184 to Pr.189** to assign signals to RY8, RYA, RYB, and RY1B to RY1D.

For details, refer to the description of **Pr.184 to Pr.189 (Input terminal function selection)** in the FR-E800 Instruction Manual (Function).

*4 While "1" is set in the frequency setting command (RYD), the set frequency (RWw1) is always applied.

*5 If "1" is set in these registers at the same time while **Pr.544 = "0"**, only one of these is executed.

*6 Refer to [page 287](#) for operation conditions of inverter reset.

*7 Torque control cannot be performed with a PM motor.

■ Input signals (from the inverter to the master module)

Input signals to the master module are as follows. (Output signals from the inverter)

Device No.	Signal	Description
RX0	Forward running	0: Other than forward running (during stop or reverse rotation) 1: Forward running
RX1	Reverse running	0: Other than reverse running (during stop or forward rotation) 1: Reverse running
RX2	Running (terminal RUN function) ^{*1}	The function assigned to Pr.190 is activated.
RX3	Up to frequency ^{*2}	SU signal
RX4	Overload warning ^{*2}	OL signal
RX5	— (terminal NET Y1 function) ^{*4}	The function assigned to Pr.193 is activated.
RX6	Frequency detection (terminal FU function) ^{*1}	The function assigned to Pr.191 is activated.
RX7	Fault (terminal ABC function) ^{*1}	The function assigned to Pr.192 is activated.
RX8	— (terminal NET Y2 function) ^{*4}	The function assigned to Pr.194 is activated.
RX9	— (DO0 function) ^{*3}	Functions assigned to Pr.313 to Pr.315 are activated.
RXA	— (DO1 function) ^{*3}	
RXB	— (DO2 function) ^{*3}	
RXC	Monitoring	After "1" is set in the monitor command (RYC), and the monitored value is set in the remote register Rwr0, 1, 4 to 7, "1" is set for this signal. When "0" is set in the monitor command (RYC), "0" is set for this signal.
RXD	Frequency setting / torque command completed (RAM)	After "1" is set in the frequency setting command / torque command (RYD), and the frequency setting / torque command is written to the RAM of the inverter, "1" is set for this signal. When "0" is set in the frequency setting command / torque command (RYD), "0" is set for this signal.
RXE	Frequency setting / torque command completed (RAM, EEPROM)	After "1" is set in the frequency setting command / torque command (RYE), and the frequency setting / torque command is written to the RAM and EEPROM of the inverter, "1" is set for this signal. When "0" is set in the frequency setting command / torque command (RYE), "0" is set for this signal.
RXF	Instruction code execution completed	After "1" is set in the instruction code execution request (RYF) and the processes corresponding to the instruction codes (RWW2, 10, 12, 14, 16 and 18) are executed, "1" is set for this signal. When "0" is set in the instruction code execution request (RYF), "0" is set for this signal.
RX16	— (terminal NET Y3 function) ^{*4}	Functions assigned to Pr.195 and Pr.196 are activated.
RX17	— (terminal NET Y4 function) ^{*4}	
RX1A	Error status flag	When an inverter error occurs (protective function is activated), "1" is set for this signal.
RX1B	Remote station ready	When the inverter is ready for communication upon completion of initial setting after power-ON or a hardware reset, "1" is set for this signal. When an inverter error occurs (protective function is activated), "0" is set for this signal.
RX1C	In-position ^{*2}	Y36 signal
RX1D	During position command operation ^{*2}	PBSY signal
RX1E	Home position return completed ^{*2}	ZP signal
RX1F	Home position return failure ^{*2}	ZA signal

*1 These signals are set in the initial setting. Using **Pr.190 to Pr.192**, output signals assigned to the device numbers can be changed.

For details of **Pr.190 to Pr.192**, refer to the FR-E800 Instruction Manual (Function).

*2 The signals are fixed. They cannot be changed using parameters.

*3 No signal is assigned in the initial setting. Use **Pr.313 to Pr.315** to assign signals to RX9 to RXB.

For details, refer to the description of **Pr.313 to Pr.315 (Output terminal function selection)** in the FR-E800 Instruction Manual (Function).

*4 No signal is assigned in the initial setting. Use **Pr.193 to Pr.196** to assign signals to RX5, RX8, RX16, and RX17.

For details, refer to the description of **Pr.193 to Pr.196 (Output terminal function selection)** in the FR-E800 Instruction Manual (Function).

◆ Details of the remote register

■ Remote register (from the master module to the inverter)

- Remote register description

Device No.	Signal	Description
RWW0	Monitor code 1, 2	Set the monitor code to be monitored (refer to page 76). When "1" is set in RYC, data of the specified monitor item will be stored in RWR0 and RWR1.

Device No.	Signal	Description	
RWw1	Set frequency ^{*1*2}	Specify the set frequency or rotations per minute (machine speed). At this time, whether to write to the RAM or EEPROM is decided with the RYD and RYE settings. After setting the set frequency in this register, set "1" in RYD or RYE to write the frequency. After writing of frequency is completed, "1" is set in RXD or RXE in response to the input command. The setting range is 0 to 590.00 Hz (0.01 Hz increments). Write "59000" when setting 590.00 Hz.	
	Torque command value	When Pr.544 CC-Link extended setting = "0, 1, or 12" and Pr.804 Torque command source selection = "3 or 5" during torque control under Real sensorless vector control or Vector control, torque command values are specified. The value is written to the inverter either by RYD or RYE. Pr.805 Torque command value (RAM) and Pr.806 Torque command value (RAM, EEPROM) are updated as well. The setting range and the setting increment depend on the Pr.804 setting. (Refer to page 78 .)	
RWw2	Link parameter extended setting / instruction code	Set an instruction code (refer to page 74) for an operation such as operation mode switching, parameter read/write, error reference, and error clear. Set "1" in RYF to execute the corresponding instruction after completing the register setting. "1" is set in RXF after completing the execution of the instruction. When a value other than "0" is set to Pr.544 , upper 8 bits are used for the link parameter extended setting. Example) When reading Pr.160 , instruction code is H0200.	
RWw3	Data to be written	Set the data specified by the instruction code of RWw2 (when required). Set "1" in RYF after setting RWw2 and this register. Set "0" when the write code is not required.	
RWw4	Monitor code 3	Set the monitor code to be monitored. By setting "1" in RYC after setting, the specified monitor data is stored in RWr4 to RWr7.	
RWw5	Monitor code 4		
RWw6	Monitor code 5		
RWw7	Monitor code 6		
RWw8	Fault record No.		Set the individual fault number of the fault history that you want to read. Fault records can be read back to the tenth latest fault. (The value in the lower 8 bits is fixed to H00.) Upper 8 bits: H00 (latest fault) to H09 (tenth latest fault) When H0A to HFF is set to the lower 8 bits, "0" is returned.
RWw9	PID set point ^{*3}	Set the PID action set point. Setting range: 0 to 100.00%	<ul style="list-style-type: none"> • Input a value 100 times greater than the value to be set. For example, enter "10000" when setting 100.00%. • For details of PID control, refer to the FR-E800 Instruction Manual (Function).
RWwA	PID measured value ^{*3}	Set the PID measured value. Setting range: 0 to 100.00%	
RWwB	PID deviation ^{*3}	Set the PID deviation. Setting range: -100.00% to 100.00%	
RWwC	Torque command value	Set Pr.544 = "14, 18, or 38" and Pr.804 = "3 or 5" to specify the torque command value during torque control under Real sensorless vector control or Vector control. The value is written to the inverter either by RYD or RYE. The values in Pr.805 and Pr.806 are updated at the same time. The setting range and the setting increment depend on the Pr.804 setting. If the data outside the range is set, the previous setting is retained.	
	Torque limit value	Set Pr.544 = "14, 18, or 38", Pr.804 = "3 or 5", and Pr.810 Torque limit input method selection = "2" to specify the torque limit value during speed control or position control under Real sensorless vector control, Vector control, or PM sensorless vector control. The value is written to the inverter either by RYD or RYE. The values in Pr.805 and Pr.806 are updated at the same time. The setting range and the setting increment depend on the Pr.804 setting (absolute value). If the data outside the range is set, the previous setting is retained.	
RWw10, RWw12, RWw14, RWw16, RWw18	Link parameter extended setting / instruction code	Set an instruction code (refer to page 74) for an operation such as operation mode switching, parameter read/write, error reference, and error clear. The instructions are executed in the following order by setting "1" in RYF after completing the register setting: RWw2, 10, 12, 14, 16, then 18. After completing the execution up to RWw18, "1" is set in RXF. Set HFFFF to disable an instruction by RWw10 to 18. (The instruction code of RWw2 is always executed.) The upper 8 bits are used for the link parameter extended setting. Example) When reading Pr.160 , instruction code is H0200.	
RWw11, RWw13, RWw15, RWw17, RWw19	Data to be written	Set the data specified by the instruction code of RWw10, 12, 14, 16, and 18 (when required). RWw10 and 11, 12 and 13, 14 and 15, 16 and 17, and 18 and 19 correspond each other. Set "1" in RYF after setting the instruction codes (RWw10, 12, 14, 16, and 18) and the corresponding register. Set "0" when the write data is not required.	

*1 The display can be changed to rotations per minute (machine speed) using **Pr.37** and **Pr.53**. For details, refer to the FR-E800 Instruction Manual (Function).

*2 When **Pr.541 Frequency command sign selection** = "1", the set frequency is a signed value. When the setting value is negative, the command is the inverse from the start command.
Setting range: -327.68 to 327.67 Hz (-32768 to 32767), 0.01 Hz increments.
For the details, refer to [page 66](#).

*3 Validity depends on the **Pr.128**, **Pr.609**, and **Pr.610** settings. For details, refer to the FR-E800 Instruction Manual (Function). If the data outside the range is set, the previous setting is retained.

■ Remote register (from the inverter to the master module)

- Remote register description

Device No.	Signal	Description
RWr0	First monitor value ^{*1*2}	When "1" is set in RYC, the monitor value is set to the lower 8 bits of the monitor code (RWw0).
RWr1	Second monitor value (output frequency ^{*1*2})	When "0" is set to the upper 8 bits of the monitor code (RWw0), the current output frequency is set. When "1" is set in RYC while a value other than "0" is set to the upper 8 bits of the monitor code (RWw0), the monitor value is set to the upper 8 bits of the monitor code (RWw0).
RWr2	Reply code (Pr.544 ≠ 0)	When "1" is set in RYD or RYE, the reply code for the frequency setting command is set. When "1" is set in RYF, the reply code corresponding to the instruction code RWw2 is set. The value "0" is set for a normal reply, and a value other than "0" is set for errors with data, mode, and other. (Refer to page 73.)
	Reply code 1 (Pr.544 ≠ 0)	Lower 8 bits of RWr2. When "1" is set in RYD or RYE, the reply code for the frequency setting command (torque command / torque limit) is set. (Refer to page 73.)
	Reply code 2 (Pr.544 ≠ 0)	Upper 8 bits of RWr2. When "1" is set in RYF, the reply code corresponding to the instruction code RWw2 is set. (Refer to page 73.)
RWr3	Data to be read	In a normal reply, a replay code for the instruction code is set.
RWr4	Third monitor value ^{*1*2}	When "1" is set in RYC, the monitor value specified to the corresponding monitor code (RWw4 to RWw7) is stored.
RWr5	Fourth monitor value ^{*1*2}	
RWr6	Fifth monitor value ^{*1*2}	
RWr7	Sixth monitor value ^{*1*2}	
RWr8	Fault record (fault data)	
RWr9	Fault record (output frequency) ^{*3}	The output frequency of the fault history No. specified in RWw8 is stored.
RWrA	Fault record (output current)	The output current of the fault history No. specified in RWw8 is always stored.
RWrB	Fault record (output voltage)	The output voltage of the fault history No. specified in RWw8 is always stored.
RWrC	Fault record (energization time)	The energization time at the fault is always stored for the fault record No. specified in RWw8.
RWr10 to RWr19	Reply code	When "1" is set in RYF, the reply codes corresponding to the instruction code RWw10, 12, 14, 16, and 18 are set. The value "0" is set for a normal reply, and a value other than "0" is set for faults with data, mode, and others. (Refer to page 73.)
	Data to be read	In a normal reply, a replay code for the instruction code is set.

*1 When the item displayed in frequency is selected, the Pr.37 and Pr.53 settings are invalid.

*2 Use Pr.290 to enable display of negative numbers during monitoring. For details, refer to the FR-E800 Instruction Manual (Function).

*3 The frequency is always displayed regardless of the settings in Pr.37 and Pr.53.

- Reply code description

The reply to the instruction execution command is set in RWr2, 10, 12, 14, 16, and 18. After the frequency setting (RYD or RYE) or execution of instruction code (RYF), check the reply code (RWr2) in the remote register.

Item	Data	Item	Fault record	Remarks
Reply code	H0000	Normal	No fault (Instruction codes are executed without any fault.)	<ul style="list-style-type: none"> • Reply code to RWr2 when Pr.544 = "0". • Reply code to RWw10, 12, 14, 16, and 18 when Pr.544 = "18 or 38".
	H0001	Write mode fault	Parameter write is attempted when the inverter is not in the stop status in the Network operation mode.	
	H0002	Parameter selection fault	Unregistered code is set.	
	H0003	Setting range fault	Set data exceeds the permissible range.	

Item	Data	Item	Fault record	Remarks
Reply code 1 ^{*1}	H00	Normal	No fault (Instruction codes are executed without any fault.)	Reply code to RWr2 when Pr.544 ≠ "0".
	H01	Write mode fault	Parameter write is attempted when the inverter is not in the stop status in the Network operation mode.	
	H03	Frequency command (torque command / torque limit) setting range error	The value outside the range is set.	
Reply code 2	H00	Normal	No fault (Instruction codes are executed without any fault.)	
	H01	Write mode fault	Parameter write is attempted when the inverter is not in the stop status in the Network operation mode.	
	H02	Parameter selection fault	Unregistered code is set.	
	H03	Setting range fault	Set data exceeds the permissible range.	

*1 The contents of the reply code 1 are changed when torque commands are given or the torque is limited (when **Pr.544** = "14, 18, or 38"). The upper 4 bits of the reply code 1 are used as the reply code to the torque command / torque limit, and the lower 4 bits are used as the reply code to the frequency command.

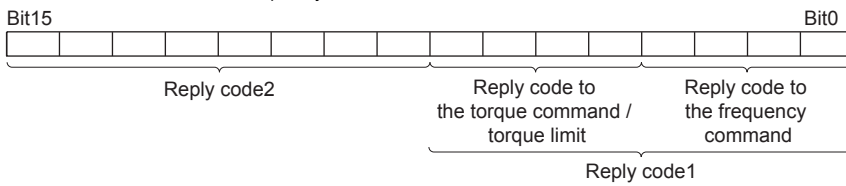

Example) When the torque command is out of the setting range, the data is H0030.

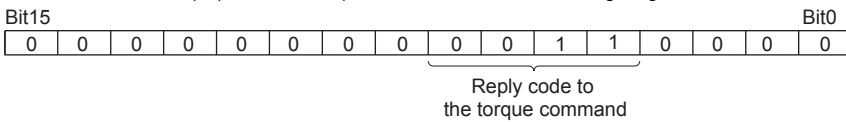

■ Instruction code

Set instruction codes using the remote register (RWw). (Refer to [page 71](#).)

The definition read by the instruction code is stored in the remote register (RWr). (Refer to [page 73](#).)

Item	Read/write	Instruction code	Data description
Operation mode	Read	H7B	H0000: Network operation H0001: External operation, External JOG operation H0002: PU operation, External/PU combined operation 1 or 2, PUJOG operation
	Write	HFB	H0000: Network operation H0001: External operation H0002: PU operation (when Pr.79 = "6")

Item		Read/write	Instruction code	Data description																																																													
Monitor	Output frequency / rotations per minute (machine speed) ^{*1*2}	Read	H6F	H0000 to HFFFF: Output frequency in 0.01 Hz increments (The display can be changed to the rotations per minute (machine speed) using Pr.37 and Pr.53 . Refer to the FR-E800 Instruction Manual (Function).)																																																													
	Output current	Read	H70	H0000 to HFFFF: Output current (hexadecimal) in 0.01 A increments																																																													
	Output voltage	Read	H71	H0000 to HFFFF: Output voltage (hexadecimal) in 0.1 V increments																																																													
	Special monitor ^{*2}	Read	H72	H0000 to HFFFF: Monitor data selected in the instruction code HF3																																																													
	Special monitor selection No.	Read	H73	H01 to HFF: Monitor selection data																																																													
		Write	HF3 ^{*3}	Refer to the monitor code description on page 76 .																																																													
Fault record	Read	H74 to H78	H0000 to HFFFF: Two fault records per code For data codes and details of fault records, refer to the FR-E800 Instruction Manual (Maintenance). <div style="display: flex; justify-content: space-between;"> <div style="width: 45%;"> <table border="1" style="width: 100%; border-collapse: collapse;"> <tr> <td style="width: 50%;">H74</td> <td style="width: 25%;">b15</td> <td style="width: 25%;">b8</td> <td style="width: 25%;">b7</td> <td style="width: 25%;">b0</td> </tr> <tr> <td></td> <td colspan="2">Second latest fault</td> <td colspan="2">Latest fault</td> </tr> <tr> <td>H75</td> <td colspan="2">Fourth latest fault</td> <td colspan="2">Third latest fault</td> </tr> <tr> <td>H76</td> <td colspan="2">Sixth latest fault</td> <td colspan="2">Fifth latest fault</td> </tr> <tr> <td>H77</td> <td colspan="2">Eighth latest fault</td> <td colspan="2">Seventh latest fault</td> </tr> <tr> <td>H78</td> <td colspan="2">Tenth latest fault</td> <td colspan="2">Ninth latest fault</td> </tr> </table> </div> <div style="width: 45%;"> <p>For instruction code H74, read data H30A0</p> <table border="1" style="width: 100%; border-collapse: collapse;"> <tr> <td style="width: 50%;">b15</td> <td style="width: 25%;">b8</td> <td style="width: 25%;">b7</td> <td style="width: 25%;">b0</td> </tr> <tr> <td>0</td> <td>0</td> <td>1</td> <td>1</td> </tr> <tr> <td>0</td> <td>0</td> <td>0</td> <td>0</td> </tr> <tr> <td>0</td> <td>0</td> <td>0</td> <td>0</td> </tr> <tr> <td>0</td> <td>0</td> <td>1</td> <td>0</td> </tr> <tr> <td>1</td> <td>0</td> <td>0</td> <td>0</td> </tr> <tr> <td>0</td> <td>0</td> <td>0</td> <td>0</td> </tr> <tr> <td>0</td> <td>0</td> <td>0</td> <td>0</td> </tr> </table> <p>Second latest fault (H30) Latest fault (HA0)</p> <p style="text-align: center;">↓</p> <p>Second latest fault THT Latest fault OPT</p> </div> </div>	H74	b15	b8	b7	b0		Second latest fault		Latest fault		H75	Fourth latest fault		Third latest fault		H76	Sixth latest fault		Fifth latest fault		H77	Eighth latest fault		Seventh latest fault		H78	Tenth latest fault		Ninth latest fault		b15	b8	b7	b0	0	0	1	1	0	0	0	0	0	0	0	0	0	0	1	0	1	0	0	0	0	0	0	0	0	0	0	0
H74	b15	b8	b7	b0																																																													
	Second latest fault		Latest fault																																																														
H75	Fourth latest fault		Third latest fault																																																														
H76	Sixth latest fault		Fifth latest fault																																																														
H77	Eighth latest fault		Seventh latest fault																																																														
H78	Tenth latest fault		Ninth latest fault																																																														
b15	b8	b7	b0																																																														
0	0	1	1																																																														
0	0	0	0																																																														
0	0	0	0																																																														
0	0	1	0																																																														
1	0	0	0																																																														
0	0	0	0																																																														
0	0	0	0																																																														
Set frequency (RAM)	Read	H6D	Read the set frequency or rotations per minute (machine speed) from the RAM or EEPROM.																																																														
Set frequency (EEPROM)		H6E	H0000 to HE678: Set frequency in 0.01 Hz increments (The display can be changed to the rotations per minute (machine speed) using Pr.37 and Pr.53 . Refer to the FR-E800 Instruction Manual (Function).) <ul style="list-style-type: none"> When Pr.544 = "0, 1, or 12" and Pr.804 = "3 or 5" during torque control under Real sensorless vector control or Vector control, torque command values are read. The setting range depends on the Pr.804 setting. 																																																														
Set frequency (RAM) ^{*4}	Write	HED	Write the set frequency or rotations per minute (machine speed) into the RAM or EEPROM.																																																														
Set frequency (RAM and EEPROM) ^{*4}		HEE	H0000 to HE678 (0 to 590.00 Hz): frequency in 0.01 Hz increments (The display can be changed to the rotations per minute (machine speed) using Pr.37 and Pr.53 . Refer to the FR-E800 Instruction Manual (Function).) <ul style="list-style-type: none"> To change the set frequency consecutively, write data to the inverter RAM. (Instruction code: HED) When Pr.544 = "0, 1, or 12" and Pr.804 = "3 or 5" during torque control under Real sensorless vector control or Vector control, torque commands are given. The setting range depends on the Pr.804 setting. 																																																														
Parameter	Read	H00 to H6B	<ul style="list-style-type: none"> Refer to the instruction codes in the FR-E800 Instruction Manual (Function) and write and/or read parameter values as required. Writing to Pr.77 and Pr.79 is disabled. When setting Pr.100 and later, set the link parameter extended setting. Set 65520 (HFFF0) as a parameter value "8888" and 65535 (HFFFF) as "9999". When changing the parameter values frequently, set "1" in Pr.342 to write them to the RAM. (For details, refer to page 282.) 																																																														
	Write	H80 to HEB																																																															
Fault history clear	Write	HF4	H9696: Fault history is cleared.																																																														
Parameter clear / All parameter clear	Write	HFC	All parameters return to initial values. Whether to clear communication parameters or not can be selected according to the data. <ul style="list-style-type: none"> Parameter clear H9696: Communication parameters are cleared. H5A5A^{*5}: Communication parameters are not cleared. All parameter clear H9966: Communication parameters are cleared. H55AA^{*5}: Communication parameters are not cleared. For the details of whether or not to clear parameters, refer to the FR-E800 Instruction Manual (Function). When clear is performed with H9696 or H9966, communication related parameter settings also return to the initial values. When resuming the operation, set the parameters again. Performing a clear will clear the instruction code HEC, HF3, and HFF settings.																																																														
Inverter reset	Write	HFD	H9696: Resets the inverter.																																																														

Item	Read/write	Instruction code	Data description
Link parameter extended setting ^{*6}	Read	H7F	Parameter settings are changed according to the instruction code settings. For details of the settings, refer to the instruction code list in the FR-E800 Instruction Manual (Function).
	Write	HFF	
Second parameter changing ^{*7}	Read	H6C	Read or write of bias and gain parameters (instruction codes H5E to H61 and HDE to HE1 with the link parameter extended setting = "1", H11 to H23 and H91 to HA3 with the link parameter extended setting = "9"). H00: Frequency ^{*8} H01: Parameter-set analog value H02: Analog value input from terminal
	Write	HEC	

- *1 When "100" is set in **Pr.52 Operation panel main monitor selection**, the frequency setting value is monitored during a stop, and the output frequency is monitored during running.
- *2 Use **Pr.290** to enable display of negative numbers during monitoring. For details, refer to the FR-E800 Instruction Manual (Function).
- *3 Write data is in hexadecimal, and only two digits are valid. (The upper two digits are ignored.)
- *4 Setting from the remote register (RWw1) is also available.
- *5 Turning OFF the power supply while clearing parameters with H5A5A or H55AA returns the communication parameter settings to the initial settings.
- *6 Setting is available only when **Pr.544** = "0". Use RWw2 or RWw10, 12, 14, 16, and 18 for setting when **Pr.544** ≠ "0". (Refer to [page 72.](#))
- *7 Reading or writing is available when the link parameter extended setting = "1 or 9".
- *8 The gain frequency can be also written using **Pr.125** (instruction code: H99) or **Pr.126** (instruction code: H9A).

NOTE

- When a 32-bit parameter setting or monitor item is read and the value to be read exceeds HFFFF, HFFFF is returned.

Monitor code

Various data of the inverter can be monitored by setting the special monitor selection No. of the instruction code and setting the monitor code in the remote registers, RWw0 and RWw4 to 7.

- Use the monitor code (RWw0) to set the first monitor value (RWr0) in the lower 8 bits, and the second monitor value (RWr1) in the upper 8 bits.
(Example) The monitor code (RWw0) will be H0602 to set the output current as the first monitor value (RWr0) and set the running speed as the second monitor value (RWr1).
- When **Pr.544** = "12, 14, 18, or 38", the values for the monitor code 3 (RWw4) to the monitor code 6 (RWw7) can be selected.

Monitor code	Second monitor (upper 8 bits)	First monitor and third–sixth monitor (lower 8 bits)	Unit
H00	Output frequency	None (monitor value fixed to "0")	0.01 Hz
H01	Output frequency		0.01 Hz
H02	Output current		0.01 A
H03	Output voltage		0.1 V
.	.	.	.
.	.	.	.
.	.	.	.

NOTE

- The monitor codes from H01 onwards and their contents are the same as those of the RS-485 communication dedicated monitor. For details of the monitor codes or monitor items, refer to the monitor display section in the FR-E800 Instruction Manual (Function).
- When the item displayed in frequency is selected in the remote registers, RWw0 and RWw4 to RWw7, the **Pr.37** and **Pr.53** settings are invalid.

◆ Communication speed and full-duplex/half-duplex selection (Pr.1426)

Use **Pr.1426 Link speed and duplex mode selection** to set the communication speed and the full-duplex or half-duplex system. If the operation is not performed properly in the initial setting (**Pr.1426** = "0"), set **Pr.1426** according to the specifications of the connected device.

Pr.1426 setting	Communication speed	Full-duplex/half-duplex system	Remarks
0 (initial value)	Automatic negotiation	Automatic negotiation	The communication speed and the communication mode (half-duplex/full-duplex) are automatically negotiated to ensure the optimum setting. To set automatic negotiation, auto negotiation setting is required also in the master station.
1	100 Mbps	Full duplex	—
2	100 Mbps	Half duplex	—
3	10 Mbps	Full duplex	The communication speed is fixed at 100 Mbps. Do not set 10 Mbps.
4	10 Mbps	Half duplex	

◆ IP filtering function (Ethernet) (Pr.1442 to Pr.1448)

- Set the IP address range for connectable network devices (**Pr.1442 to Pr.1448**) to limit the connectable devices. The setting range for IP address of connectable network devices depends on the settings in **Pr.1443** and **Pr.1446**, **Pr.1444** and **Pr.1447**, and **Pr.1445** and **Pr.1448**. (Either of the settings can be larger than the other in **Pr.1443** and **Pr.1446**, **Pr.1444** and **Pr.1447**, and **Pr.1445** and **Pr.1448**.)

[Setting example 1]

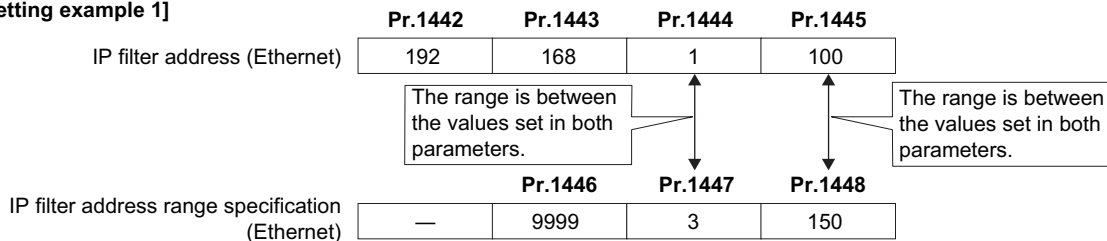

In this case, the IP address range in which Ethernet communication is permitted is "192.168.x (1 to 3).xxx (100 to 150)".

[Setting example 2]

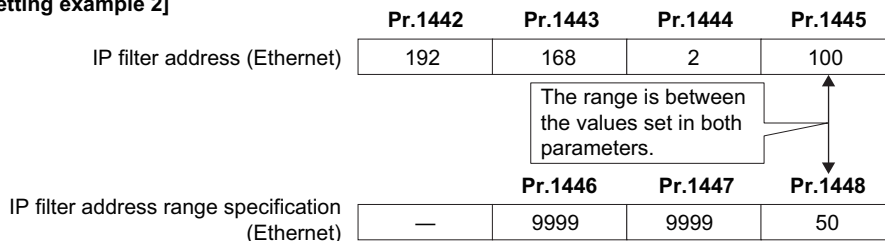

In this case, the IP address range in which Ethernet communication is permitted is "192.168.2.xxx (50 to 100)".

- When **Pr.1442 to Pr.1445** = "0 (initial value)", the function is invalid.
- When "9999 (initial value)" is set in **Pr.1446 to Pr.1448**, the range is invalid.

⚠ CAUTION

- The IP filtering function (Ethernet) (**Pr.1442 to Pr.1448**) is provided as a means to prevent unauthorized access, DoS attacks, computer viruses, or other cyberattacks from external devices, but the function does not prevent such access completely. In order to protect the inverter and the system against unauthorized access by external systems, take additional security measures. We shall have no responsibility or liability for any problems involving inverter trouble and system trouble by DoS attacks, unauthorized access, computer viruses, and other cyberattacks. The following are examples of measures to prevent them.
 - Install a firewall.
 - Install a personal computer as a relay station, and control the relaying of transmission data using an application program.
 - Install an external device as a relay station to control access rights. (For the details of external devices used to control access rights, contact the distributors of the external devices.)

◆ Torque command / torque limit using the CC-Link IE Field Network Basic

Torque commands can be given or the torque can be limited on the CC-Link IE Field Network Basic under Real sensorless vector control, Vector control, or PM sensorless vector control. The value is used to limit the torque during speed control or position control, and to give a torque command during torque control. To limit the torque, set **Pr.810 Torque limit input method selection** = "2". The torque command / torque limit setting method can be selected using **Pr.804 Torque command source selection**. (Torque control cannot be performed with a PM motor.)

Pr.	Name	Initial value	Setting range	Description
804	Torque command source selection	0	0	Torque command given by analog input via terminal 4
			1	Torque command / torque limit using the CC-Link IE Field Network Basic • Torque command / torque limit (-400% to 400%) by the parameter setting (Pr.805 or Pr.806) ^{*1*2}
			3	Torque command / torque limit using the CC-Link IE Field Network Basic • Torque command / torque limit (-400% to 400%) by the parameter setting (Pr.805 or Pr.806) ^{*1*2} • Setting is available using the remote register RWw1 or RWwC (-400% to 400%). ^{*2}
			4	Torque command given by 16-bit digital input (FR-A8AX)
			5	Torque command / torque limit using the CC-Link IE Field Network Basic • Torque command / torque limit (-327.68% to 327.67%) by the parameter setting (Pr.805 or Pr.806) (-327.68% to 327.67%) ^{*1*2} • Setting is available using the remote register RWw1 or RWwC (-327.68% to 327.67%). ^{*2}
			6	Torque command / torque limit using the CC-Link IE Field Network Basic • Torque command / torque limit (-327.68% to 327.67%) by the parameter setting (Pr.805 or Pr.806) ^{*1*2}
810	Torque limit input method selection	0	0	Internal torque limit (torque limited by parameter settings)
			1	External torque limit (torque limited by terminal 4)
			2	Internal torque limit 2 (torque limited by CC-Link IE Field Network Basic)

*1 The value can also be set using the operation panel.

*2 When a negative value is set as the torque limit, the torque is limited by the absolute value.

■ List of I/O devices whose function is changed according to the parameter settings and the control method

Pr.544 setting	I/O device	V/F control / Advanced magnetic flux vector control	Real sensorless vector control / Vector control / PM sensorless vector control	
			Speed control / position control	Torque control ^{*3}
—	RYD	Frequency setting command (RAM)	Frequency setting / torque limit command (RAM)	Torque command (RAM)
—	RYE	Frequency setting command (RAM, EEPROM)	Frequency setting / torque limit command (RAM, EEPROM)	Torque command (RAM, EEPROM)
—	RXD	Frequency setting completion (RAM)	Frequency setting / torque limit completion (RAM)	Torque command completion (RAM)
—	RXE	Frequency setting completion (RAM, EEPROM)	Frequency setting / torque limit completion (RAM, EEPROM)	Torque command completion (RAM, EEPROM)
0, 1, 12 14, 18, 38	RWw1	Set frequency	Set frequency	Torque command ^{*1}
0, 1, 12 14, 18, 38				—
0, 1, 12 14, 18, 38	RWwC	—	—	—
0, 1, 12 14, 18, 38			Torque limit ^{*1*2}	Torque command ^{*1}

*1 Set **Pr.804** = "3 or 5".

*2 Set **Pr.810** = "2".

*3 Torque control cannot be performed with a PM motor.

■ Torque command setting method and the parameter for speed limit

Pr.804 setting	Pr.544 setting	Torque command setting method (any one of the following)	Parameter for speed limit
3, 5	0, 1, 12	<ul style="list-style-type: none"> Set the torque command value in RWwn+1, and "1" in RYD or RYE. Set the instruction code HED or HEE in RWwn+2, the torque command value in RWwn+3, and "1" in RYF. (The torque command value can be read using the instruction code H6D or H6E.) Set H08 in the link parameter extended setting, the instruction code H85 and H86 in RWwn+2, the torque command value in RWwn+3, and "1" in RYF. (Writing in Pr.805 or Pr.806) 	Pr.808, Pr.809
	14, 18, 38	<ul style="list-style-type: none"> Set the torque command value in RWwn+C, and "1" in RYD or RYE. Set H08 in the link parameter extended setting, the instruction code H85 and H86 in RWwn+2, the torque command value in RWwn+3, and "1" in RYF. (Writing in Pr.805 or Pr.806) 	Pr.807
1, 6	0, 1, 12, 14, 18, 38	Set H08 in the link parameter extended setting, the instruction code H85 and H86 in RWwn+2, the torque command value in RWwn+3, and "1" in RYF. (Writing in Pr.805 or Pr.806)	
0, 4	—	Torque command using the CC-Link IE Field Network Basic is not available.	

2

■ Torque limit setting method

Pr.804 setting	Pr.810 setting	Pr.544 setting	Torque limit setting method (any one of the following)
3, 5	2	14, 18, 38	<ul style="list-style-type: none"> Set the torque limit value in RWwn+C, and "1" in RYD or RYE. Set H08 in the link parameter extended setting, the instruction code H85 and H86 in RWwn+2, the torque limit value in RWwn+3, and "1" in RYF. (Writing in Pr.805 or Pr.806)
1, 6		0, 1, 12, 14, 18, 38	Set H08 in the link parameter extended setting, the instruction code H85 and H86 in RWwn+2, the torque limit value in RWwn+3, and "1" in RYF. (Writing in Pr.805 or Pr.806)

■ Relationship between the Pr.804 setting, the setting range, and the actual torque command / torque limit (when setting is made from CC-Link IE Field Network Basic communication)

Pr.804 setting	Setting range	Actual torque command	Actual torque limit
1, 3	600 to 1400 (1% increments) ^{*1}	-400 to 400%	0 to 400%
5, 6	-32768 to 32767 (two's complement) ^{*1}	-327.68 to 327.67%	0 to 327.67%

*1 The torque limit setting is defined as an absolute value.

◆ Programming examples

The following explains the programming examples for controlling the inverter with sequence programs.

Item	Program example	Refer to page
Reading the inverter status	Reading the inverter status from the buffer memory of the master station	81
Setting the operation mode	Selecting the Network operation mode	81
Setting the operation commands	Commanding the forward rotation and middle speed signals	82
Setting the monitoring function	Monitoring the output frequency	82
Reading a parameter value	Reading the value of Pr.7 Acceleration time	83
Writing a parameter value	Setting 3.0 seconds in Pr.7 Acceleration time	83
Frequency setting (speed setting)	Setting to 50.00 Hz	84
Reading the fault records	Reading the inverter faults	85
Inverter reset	Resetting the inverter when an inverter error occurs	85

- System configuration example (when the MELSEC iQ-R series programmable controller is used)

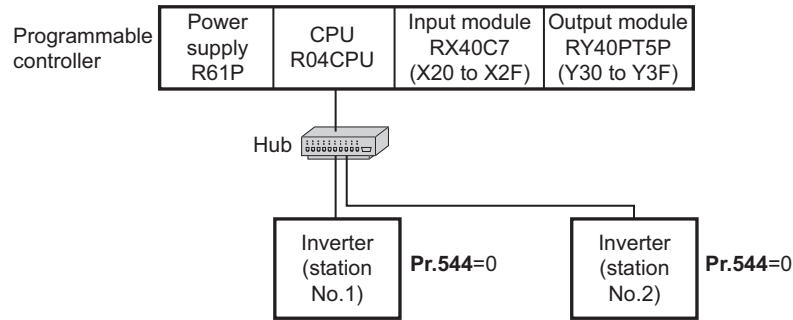

- Setting network parameters of the master station
In the programming example, network parameters are set as follows.

Item	Setting condition
Station type	CC-Link IE Field Network Basic (master station)
Start I/O	0000
Quantity	2
Remote input (RX)	X1000
Remote output (RY)	Y1000
Remote register (RW _r)	W0
Remote register (RW _w)	W100
Retry count	3

■ Schematic diagrams of remote I/O and remote register devices

- The following diagram shows the remote I/O (RX and RY) transmitted between the programmable controller CPU and remote stations. Shaded areas show the devices actually used.

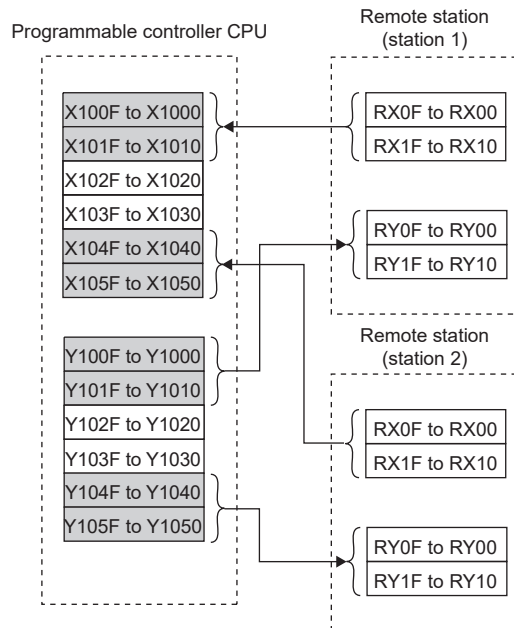

- The following diagram shows the remote register areas (RWw and RWr) transmitted between the programmable controller CPU and remote stations. Shaded areas show the devices actually used.

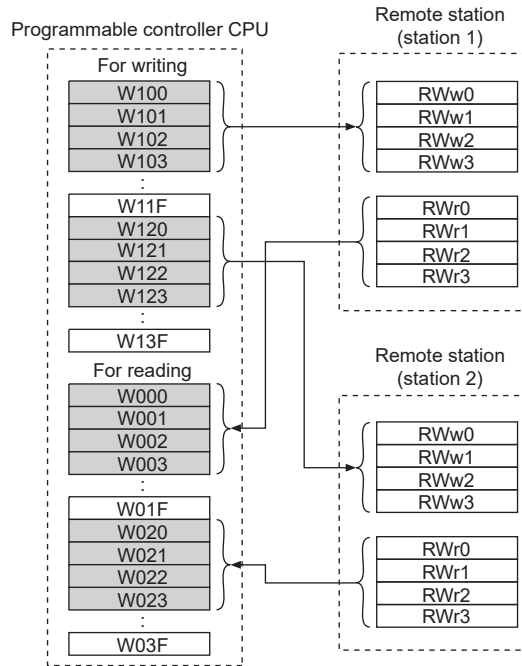

■ Programming example for reading the inverter status

The following program turns ON the signal Y00 of the output unit when the station 1 inverter starts running.

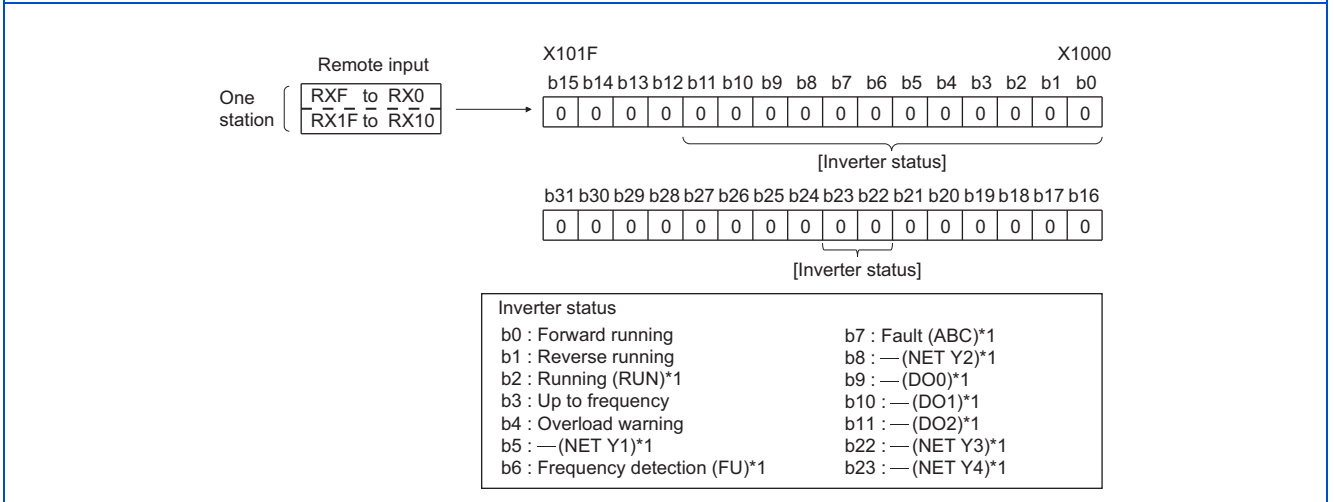
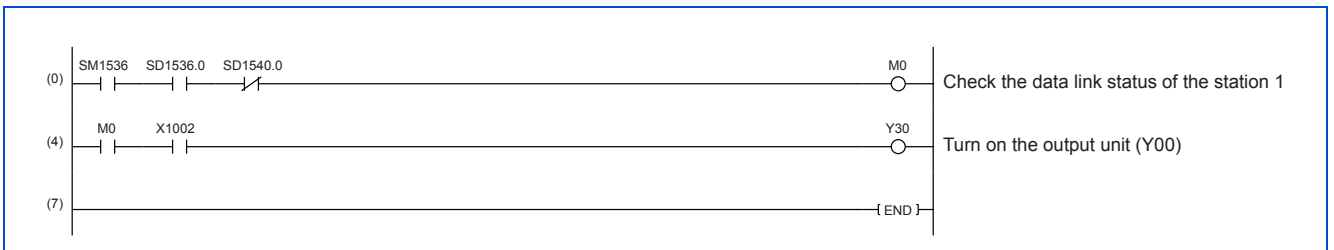

*1 These signals are assigned in the initial status. Use Pr.190 to Pr.196 and Pr.313 to Pr.315 (Output terminal function selection) to change the output signals.

■ Programming example for setting the operation mode

The following explains a program to write various data to the inverter.

The following program changes the operation mode of the station 1 inverter to network operation.

- Operation mode write code: HFB (hexadecimal)
- Network operation set data: H0000 (hexadecimal) (Refer to page 74.)

Example) The output frequency of 60 Hz is indicated as "H1770 (6000)".

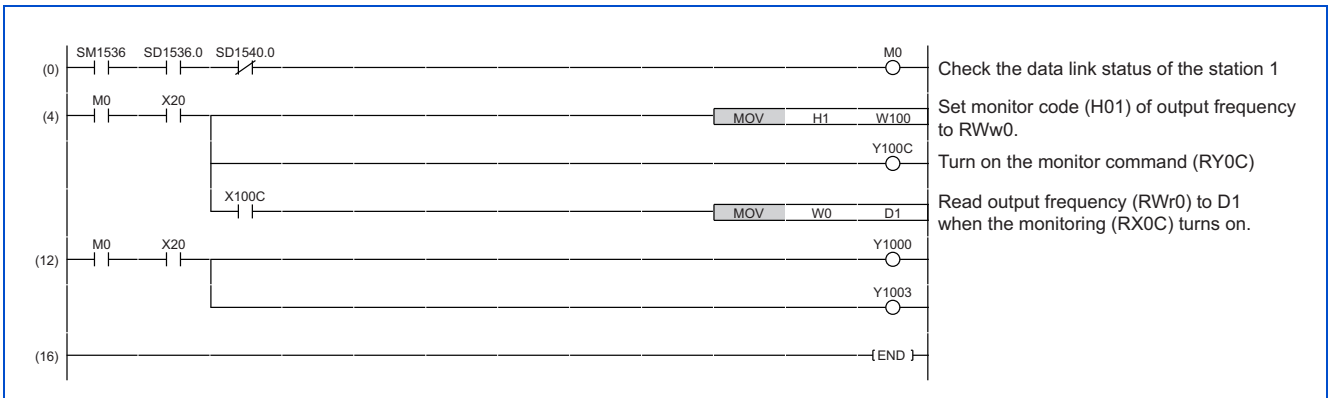

■ Programming example for the parameter reading

The following program reads **Pr.7 Acceleration time** of the station 1 inverter to output to D1.

- **Pr.7 Acceleration time** reading instruction code: H07 (hexadecimal)
- For the instruction codes of parameters, refer to the Instruction Manual (Function).
- The reply code to the instruction code execution is set in D2. (Refer to [page 73.](#))

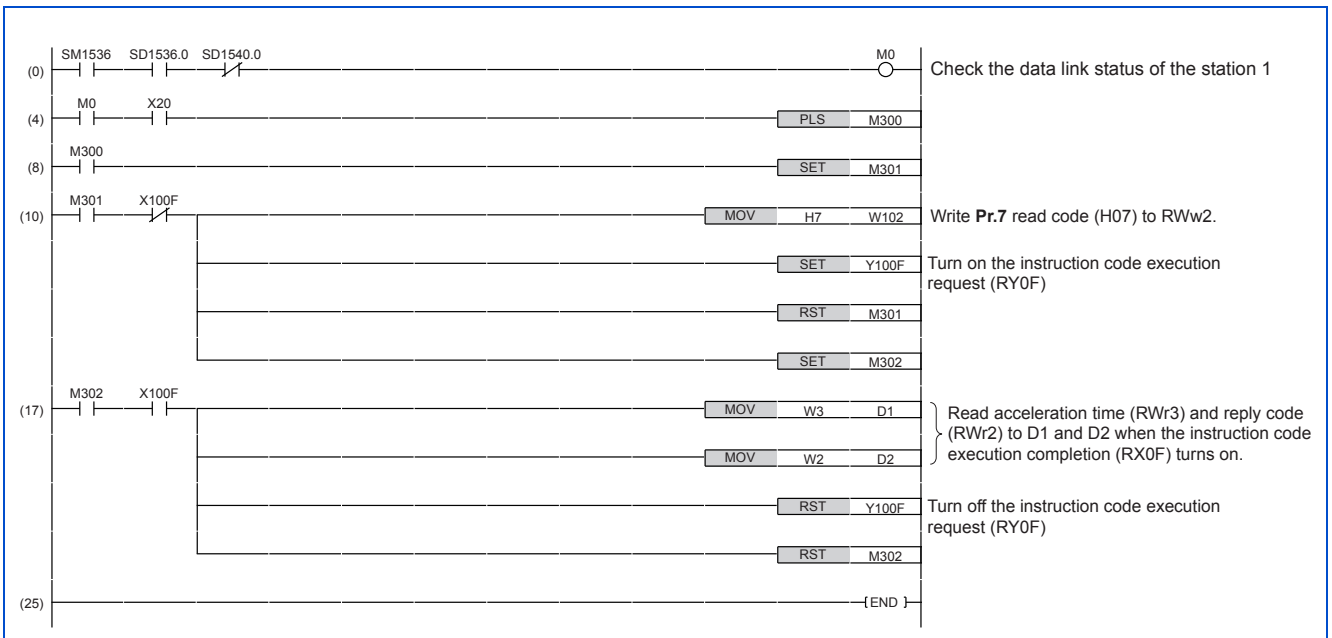

NOTE

- For the parameter assigned the number of 100 or higher, change the link parameter extended setting (set it to the one other than H00). For the setting values, refer to the instruction code list of the Instruction Manual (Function).

■ Programming example for the parameter writing

The following program changes the setting value in **Pr.7 Acceleration time** of the station 1 inverter to 3.0 seconds.

- Acceleration time writing instruction code: H87 (hexadecimal)
- Acceleration time setting data: K30 (decimal)

For the instruction codes of parameters, refer to the Instruction Manual (Function).

<Timing chart when writing to RAM>

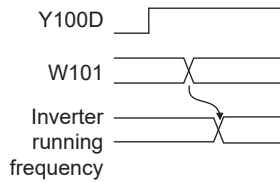

<Timing chart when writing to EEPROM>

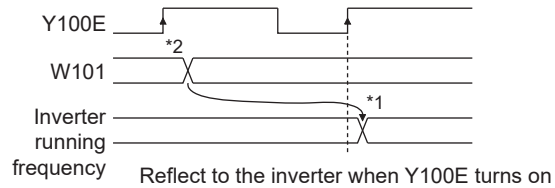

*1 To the EEPROM, a writing is performed only once after the command Y100E turns ON.

*2 If the set data is changed at the command Y100E ON, the change is not applied to the inverter.

■ Programming example for the fault record reading

The following program reads the fault records of the station 1 inverter to output to D1.

- Fault history No. 1 and 2 reading instruction code: H74 (hexadecimal)

For the error codes, refer to the Instruction Manual (Maintenance).

The reply code to the instruction code execution is set in D2. (Refer to [page 73](#).)

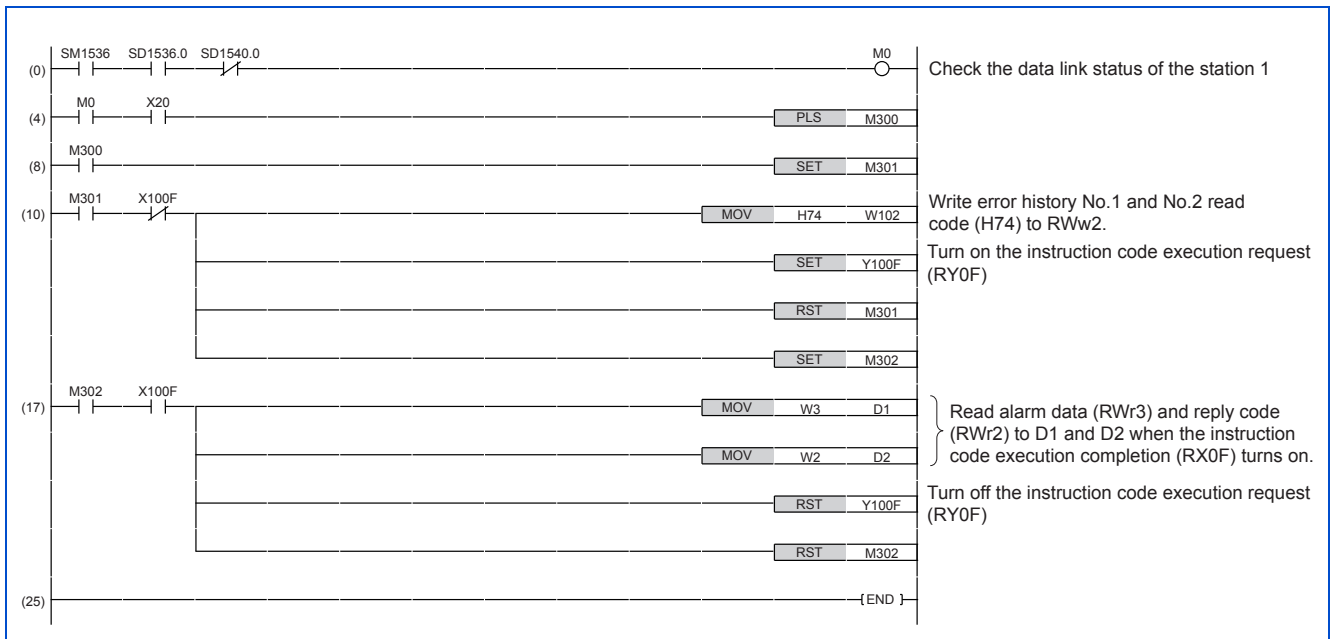

■ Programming example for resetting the inverter at an inverter fault

The following program resets the station 1 inverter at an inverter fault.

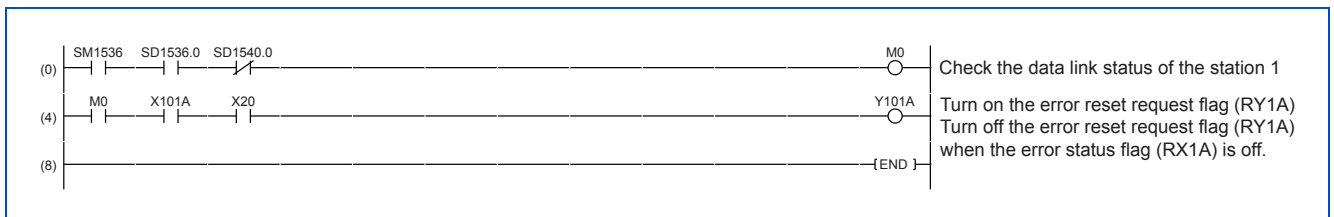

NOTE

- The inverter reset with the flag RY1A shown above is enabled at an inverter fault only.
- When **Pr.349 Communication reset selection** = "0", inverter reset is available independently of the operation mode.
- When using the instruction code execution request (RY0F) with the instruction code (HFD) and data (H9696) to reset the inverter, set a value other than "0" in **Pr.340 Communication startup mode selection** or change the operation mode to the Network operation mode. (For the program example, refer to [page 81](#).)
- Refer to [page 287](#) for operation conditions of inverter reset.

◆ Instructions

■ Operating and handling instructions

- The inverter only accepts the commands from the programmable controller during operation using the CC-Link IE Field Network Basic. Operation commands input from external devices are ignored.
- If multiple inverters have the same station number, the communication cannot be performed properly.
- The inverter protective function (E.EHR) is activated if data communication stops for more than the time set in **Pr.1432 Ethernet communication check time interval** due to a programmable controller fault, an open Ethernet cable or other factors during CC-Link IE Field Network Basic operation.
- If the programmable controller (master station) is reset during operation through the CC-Link IE Field Network Basic or if the programmable controller is powered off, data communication stops and the inverter protective function (E.EHR) is activated. To reset the programmable controller (master station), switch the operation mode to the External operation once, then reset the programmable controller.
- When **Pr.340** = "0", any inverter whose main power is restored is reset to return to the External operation mode. To resume the Network operation, therefore, set the operation mode to the Network operation using the sequence program. Set a value other than "0" in **Pr.340** to start in the Network operation mode after inverter reset. (For details of **Pr.340**, refer to the FR-E800 Instruction Manual (Function).)

■ Troubleshooting

Description	Point to be checked
Communication is not established.	Check that the communication speed is not set to 10 Mbps.
Operation mode does not switch to the Network operation mode.	Check that the Ethernet cable is installed correctly. (Check for contact fault, break in the cable, etc.)
	Check that the inverter is in the External operation mode.
	Check that the operation mode switching program is running.
	Check that the operation mode switching program has been written correctly.
Inverter does not start in the Network operation mode.	Check that the inverter starting program is running.
	Check that the inverter starting program has been written correctly.
	Check that Pr.338 Communication operation command source is not set to External.

2.6.5 Group number setting

Set a group number to each remote station to divide remote stations into groups and perform cyclic transmission by the group. By grouping the remote stations by their reference response times, cyclic transmission can be performed smoothly regardless of the differences of the reference response times. (Refer to the CC-Link IE Field Network Basic Reference Manual (SH-081684ENG) for the details.)

- Star topology

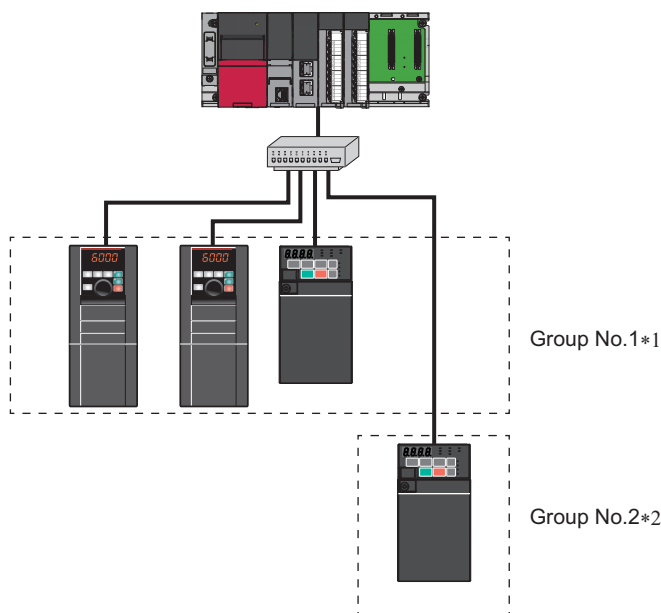

• Line topology

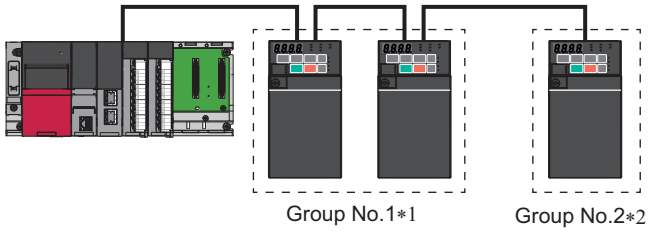

*1 The number of occupied stations for one group is up to 16.

*2 Up to four groups can be organized.

2.7 MODBUS/TCP

2.7.1 Outline

MODBUS/TCP is available for the FR-E800-(SC)EPA, FR-E806-SCEPA, FR-E800-(SC)EPB, and FR-E806-SCEPB.

The MODBUS/TCP protocol allows transmission of MODBUS messages via Ethernet communication.

Some functions are not supported depending on the date of manufacture of the inverter. For details of specification changes, refer to [page 290](#).

◆ Communication specifications

The communication specifications are shown in the following table.

Item		Description
Communication protocol		MODBUS/TCP protocol
Conforming standard		OPEN MODBUS/TCP SPECIFICATION
Time delay setting		Not available
Maximum number of connections ^{*1}		3
Topology		Line, star, or a combination of line and star
Server function	Number of simultaneously acceptable request messages	1 to 3

*1 This indicates the number of connections which can be simultaneously established by the inverter. The maximum number of connected units depends on the maximum number of connections of the client and the number of connections per inverter. For example, when the maximum number of connections of the client is 64 and one connection is used per inverter, up to 64 units can be connected. For details, refer to the User's Manual of the client.

2.7.2 Initial setting for MODBUS/TCP

Use the following parameters to perform required settings for Ethernet communication between the inverter and other devices.

To make communication between other devices and the inverter, perform the initial settings of the inverter parameters to match the communication specifications of the devices. Data communication cannot be made if the initial settings are not configured or if there is any setting error.

Pr.	Name	Initial value	Setting range	Description
1427 N630 ^{*1}	Ethernet function selection 1	5001	502, 5000 to 5002, 5006 to 5008, 5010 to 5013, 9999, 34962 ^{*3} , 44818 ^{*2} , 45237, 45238, 47808 ^{*2} , 61450	Set the application, protocol, etc.
1428 N631 ^{*1}	Ethernet function selection 2	45237		
1429 N632 ^{*1}	Ethernet function selection 3	45238		
1430 N633 ^{*1}	Ethernet function selection 4	9999		
1432 N644	Ethernet communication check time interval	1.5 s	0	Ethernet communication is available, but the inverter output is shut off in the NET operation mode.
			0.1 to 999.8 s	Set the interval of the communication check (signal loss detection) time for all devices with IP addresses in the range specified for Ethernet command source selection (Pr.1449 to Pr.1454). If a no-communication state persists for longer than the permissible time, the inverter output will be shut off.
			9999	No communication check (signal loss detection)

Pr.	Name	Initial value	Setting range	Description
1449 N670 ^{*1}	Ethernet command source selection IP address 1	0	0 to 255	To limit the network devices that send the operation or speed command through the Ethernet network, set the range of IP addresses of the devices. When Pr.1449 to Pr.1452 = "0 (initial value)", no IP address is specified for command source selection via Ethernet. In this case, operation commands cannot be sent via Ethernet.
1450 N671 ^{*1}	Ethernet command source selection IP address 2	0		
1451 N672 ^{*1}	Ethernet command source selection IP address 3	0		
1452 N673 ^{*1}	Ethernet command source selection IP address 4	0		
1453 N674 ^{*1}	Ethernet command source selection IP address 3 range specification	9999	0 to 255, 9999	
1454 N675 ^{*1}	Ethernet command source selection IP address 4 range specification	9999		

*1 The setting is applied after an inverter reset or next power-ON.

*2 The setting is available for the FR-E800-(SC)EPA and FR-E806-SCEPA.

*3 The setting is available for the FR-E800-(SC)EPB and FR-E806-SCEPB.

NOTE

- The monitor items and parameter settings can be read during communication with the **Pr.1432 Ethernet communication check time interval** = "0 (initial value)" setting, but such operation will become faulty once the operation mode is changed to the NET operation mode. When the NET operation mode is selected as the start-up operation mode, communication is performed once, then an Ethernet communication fault (E.EHR) occurs.
To perform operation or parameter writing via communication, set **Pr.1432** to "9999" or a value larger than the communication cycle or retry time setting. (Refer to [page 90](#).)

◆ Ethernet function selection (Pr.1427 to Pr.1430)

To select MODBUS/TCP for the application, set "502" (MODBUS/TCP) in any of **Pr.1427 to Pr.1430 Ethernet function selection 1 to 4**. (Refer to [page 226](#).)

◆ Ethernet IP address for command source selection (Pr.1449 to Pr.1454)

- To limit the network devices that send the operation or speed command through the Ethernet network, set the range of IP addresses of the devices.
- When **Pr.1449 to Pr.1452** = "0 (initial value)", no IP address is specified for command source selection via Ethernet. In this case, operation commands cannot be sent via Ethernet.

- The setting range for command source selection depends on the settings in **Pr.1451** and **Pr.1453**, and **Pr.1452** and **Pr.1454**. (Either of the settings can be larger than the other in **Pr.1451** and **Pr.1453**, and **Pr.1452** and **Pr.1454**.)

**[Setting example 1]
Configuration**

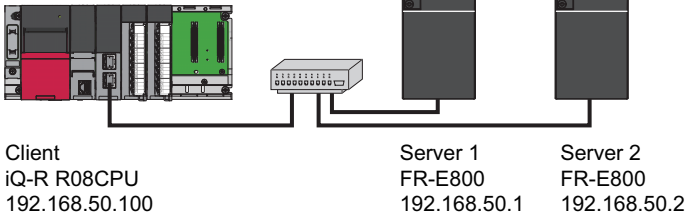

To allow the client to control the servers, set the parameters in servers 1 and 2 as follows to specify the IP address range for Ethernet command source selection.

Set the IP address of the client in the engineering software (GX Works3) within the range from 192.168.50.100 to 192.168.50.110.

	Pr.1449	Pr.1450	Pr.1451	Pr.1452
Ethernet IP address for command source selection	192	168	50	100
	The range is between the values set in both parameters.			
			Pr.1453	Pr.1454
Command source selection range setting for the Ethernet IP address	—	—	9999	110

In this case, the IP address range in which Ethernet communication is permitted is "192.168.50.xxx (100 to 110)".

[Setting example 2]

	Pr.1449	Pr.1450	Pr.1451	Pr.1452
Ethernet IP address for command source selection	192	168	1	100
	The range is between the values set in both parameters.		The range is between the values set in both parameters.	
			Pr.1453	Pr.1454
Command source selection range setting for the Ethernet IP address	—	—	3	150

In this case, the IP address range for command source selection via Ethernet communication is "192.168.x (1 to 3).xxx (100 to 150)".

- When "9999 (initial value)" is set in **Pr.1453** or **Pr.1454**, the range is invalid.

NOTE

- When four or more clients attempt a connection to the inverter, the connection attempted from outside of the IP address range set for Ethernet command source selection will be forced to be closed in order from the oldest.

◆ Ethernet communication check time interval (Pr.1432)

- If a signal loss (communication stop) is detected between the inverter and all the devices with IP addresses in the range for Ethernet command source selection (**Pr.1449 to Pr.1454**) as a result of a signal loss detection, a communication error (E.EHR) occurs and the inverter output will be shut off.
- When "9999" is set in **Pr.1432**, the communication check (signal loss detection) will not be performed.
- The monitor items and parameter settings can be read via Ethernet when "0" is set in **Pr.1432**, but a communication error (E.EHR) occurs instantly when the operation mode is switched to the Network operation.
- A signal loss detection is made when any of 0.1 s to 999.8 s is set in **Pr.1432**. In order to enable the signal loss detection, data must be sent by connected devices at an interval equal to or less than the time set for the communication check. (The inverter makes a communication check (clearing of communication check counter) regardless of the station number setting of the data sent from the client.)

- Communication check is started at the first communication when the inverter operates in the Network operation mode and the command source is specified as communication via the Ethernet connector.

Example) When Pr.1432 = 0.1 to 999.8 s

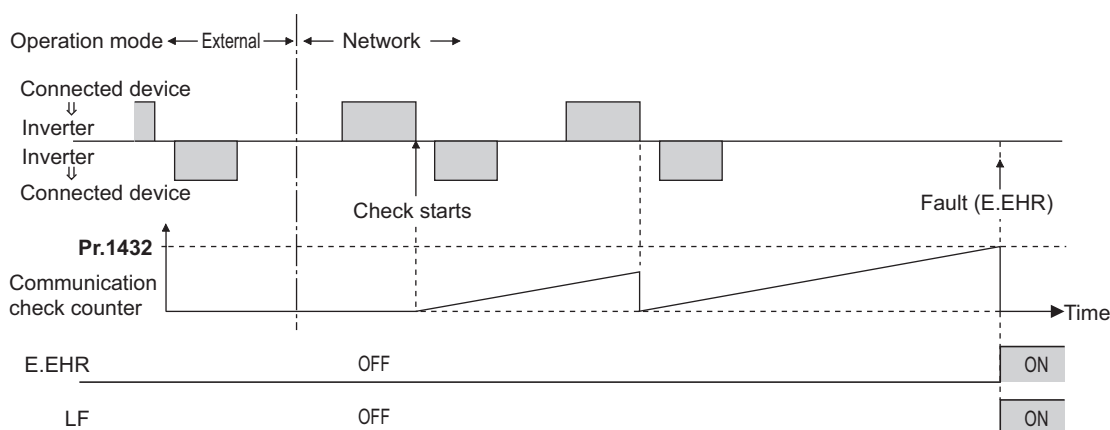

2.7.3 Parameters related to MODBUS/TCP

The following parameters are used for MODBUS/TCP communication. Set the parameters as required.

Pr.	Name	Initial value	Setting range	Setting range
1426 N641 ^{*1}	Link speed and duplex mode selection	0	0 to 4	Set the communication speed and the communication mode (full-duplex/half-duplex).
1442 N660 ^{*1}	IP filter address 1 (Ethernet)	0	0 to 255	Set the range of connectable IP addresses for the network devices. (When Pr.1442 to Pr.1445 = "0 (initial value)", the function is invalid.)
1443 N661 ^{*1}	IP filter address 2 (Ethernet)	0		
1444 N662 ^{*1}	IP filter address 3 (Ethernet)	0		
1445 N663 ^{*1}	IP filter address 4 (Ethernet)	0		
1446 N664 ^{*1}	IP filter address 2 range specification (Ethernet)	9999	0 to 255, 9999	
1447 N665 ^{*1}	IP filter address 3 range specification (Ethernet)	9999		
1448 N666 ^{*1}	IP filter address 4 range specification (Ethernet)	9999		

*1 The setting is applied after an inverter reset or next power-ON.

◆ Communication speed and full-duplex/half-duplex selection (Pr.1426)

Use Pr.1426 Link speed and duplex mode selection to set the communication speed and the full-duplex or half-duplex system. If the operation is not performed properly in the initial setting (Pr.1426 = "0"), set Pr.1426 according to the specifications of the connected device.

Pr.1426 setting	Communication speed	Full-duplex/half-duplex system	Remarks
0 (initial value)	Automatic negotiation	Automatic negotiation	The communication speed and the communication mode (half-duplex/full-duplex) are automatically negotiated to ensure the optimum setting. To set automatic negotiation, auto negotiation setting is required also in the client.
1	100 Mbps	Full duplex	—
2	100 Mbps	Half duplex	—
3	10 Mbps	Full duplex	—
4	10 Mbps	Half duplex	—

◆ IP filtering function (Ethernet) (Pr.1442 to Pr.1448)

- Set the IP address range for connectable network devices (**Pr.1442 to Pr.1448**) to limit the connectable devices. The setting range for IP address of connectable network devices depends on the settings in **Pr.1443** and **Pr.1446**, **Pr.1444** and **Pr.1447**, and **Pr.1445** and **Pr.1448**. (Either of the settings can be larger than the other in **Pr.1443** and **Pr.1446**, **Pr.1444** and **Pr.1447**, and **Pr.1445** and **Pr.1448**.)

[Setting example 1]

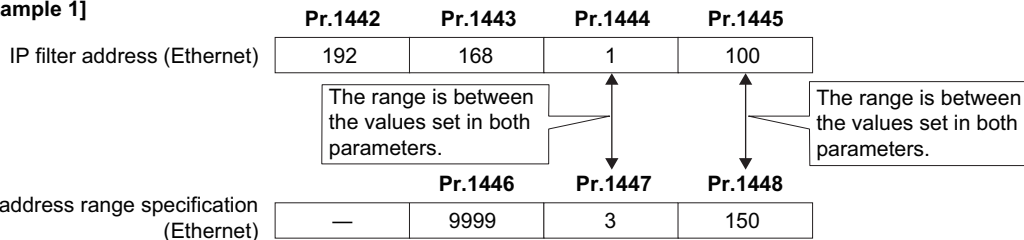

In this case, the IP address range in which Ethernet communication is permitted is "192.168.x (1 to 3).xxx (100 to 150)".

[Setting example 2]

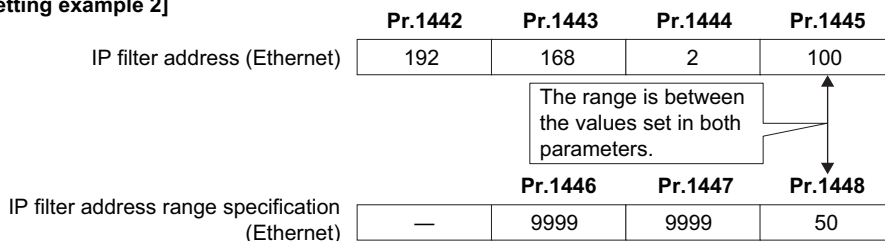

In this case, the IP address range in which Ethernet communication is permitted is "192.168.2.xxx (50 to 100)".

- When **Pr.1442 to Pr.1445** = "0 (initial value)", the function is invalid.
- When "9999 (initial value)" is set in **Pr.1446 to Pr.1448**, the range is invalid.

⚠ CAUTION

- The IP filtering function (Ethernet) (**Pr.1442 to Pr.1448**) is provided as a means to prevent unauthorized access, DoS attacks, computer viruses, or other cyberattacks from external devices, but the function does not prevent such access completely. In order to protect the inverter and the system against unauthorized access by external systems, take additional security measures. We shall have no responsibility or liability for any problems involving inverter trouble and system trouble by DoS attacks, unauthorized access, computer viruses, and other cyberattacks. The following are examples of measures to prevent them.
 - Install a firewall.
 - Install a personal computer as a relay station, and control the relaying of transmission data using an application program.
 - Install an external device as a relay station to control access rights. (For the details of external devices used to control access rights, contact the distributors of the external devices.)

◆ Message format

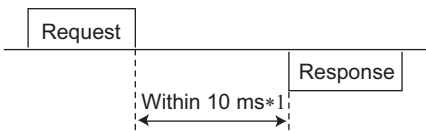

*1 The chart shows the performance when the inverter is connected to a client on a 1:1 basis. (It takes 10 ms or more for Parameter clear, All parameter clear, or accessing multiple registers.)

- Query**
A message is sent to the server (the inverter) having the address specified by the client.
- Normal Response**
After the query from the client is received, the server executes the request function, and returns the corresponding normal response to the client.
- Error Response**
When an invalid function code, address or data is received by the server, the error response is returned to the client. This response is appended with an error code that indicates the reason why the request from the client could not be executed.

◆ Message frame (protocol)

- Communication method

Basically, the client sends a query message (inquiry), and servers return a response message (response). At normal communication, the transaction identifier, protocol identifier, unit identifier, and function code are copied as they are, and at erroneous communication (illegal function code or data code), bit 7 (= H80) of the function code is turned ON, and the error code is set at data bytes.

Query message from client

Transaction Identifier
Protocol Identifier
Length Field
Unit Identifier
Function Code
Eight-Bit Data Bytes

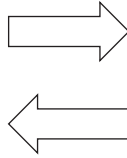

Transaction Identifier
Protocol Identifier
Length Field
Unit Identifier
Function Code
Eight-Bit Data Bytes

Response message from server

Message frames have the six message fields shown in the figures above.

- Details of protocol

The following table explains the six message fields.

Transaction identifier	Protocol identifier	Length field	Unit identifier	Function	Data
2 × 8 bits	2 × 8 bits	2 × 8 bits	8 bits	8 bits	n × 8 bits

Message field	Description
Transaction identifier	The client adds the data for the purpose of transaction control. The same data is returned in the response from the server.
Protocol identifier	Fixed to 0. (When the server receives data other than 0, it does not send the response message.) "0" is returned in the response from the server.
Length field	The data length from the unit identifier to the data is stored in byte.
Unit identifier	0, 255
Function code	"1 to 255" can be set as the function code in the single-byte (8-bit) length field. The client sets the function to be sent to the server as the request, and the server performs the requested operation. Refer to the function code list for details of the supported function codes. An error response is generated when a function code other than those in the function code list is set. The normal response from the server contains the function code set by the client. The error response contains H80 and the function code.
Data	The format changes according the function code. (Refer to page 94 .) The data, for example, includes the byte count, number of bytes, and accessing content of holding registers.

◆ Function code list

Function name	Read/write	Code	Outline	Message format reference page
Read holding registers	Read	H03	The data of the holding registers is read. The various data of the inverter can be read from MODBUS registers. System environmental variable (Refer to page 100 .) Monitor code (Refer to the FR-E800 Instruction Manual (Function).) Fault history (Refer to page 102 .) Model information monitor (Refer to page 102 .) Inverter parameters (Refer to page 101 .) CiA402 drive profile (Refer to page 103 .)	page 94
Write Single Register	Write	H06	Data is written to a holding register. Data can be written to MODBUS registers to output instructions to the inverter or set parameters. System environmental variable (Refer to page 100 .) Inverter parameters (Refer to page 101 .)	page 95
Diagnostics	Read	H08	Functions are diagnosed. (Communication check only) A communication check can be made since the query message is sent and the query message is returned as it is as the return message (subfunction code H00 function). Subfunction code H00 (Return query data).	page 95

Function name	Read/write	Code	Outline	Message format reference page
Write Multiple Registers	Write	H10	Data is written to multiple consecutive holding registers. Data can be written to consecutive multiple MODBUS registers to output instructions to the inverter or set parameters. System environmental variable (Refer to page 100.) Inverter parameters (Refer to page 101.) CiA402 drive profile (Refer to page 103.)	page 96
Read holding register access log	Read	H46	The number of registers that were successfully accessed by the previous communication is read. Queries by function codes H03, H06, and H10 are supported. The number and start address of holding registers successfully accessed by the previous communication are returned. "0" is returned for both the number and start address for queries other than function codes H03, H06, and H10. When the connection is closed, the data in the log is cleared.	page 97

◆ Read holding registers (reading data of holding registers) (H03 or 03)

- Query message

a. Transaction identifier		b. Protocol identifier		c. Length field		d. Unit identifier	e. Function code	f. Starting address		g. Quantity of registers	
H (8 bits)	L (8 bits)	H (8 bits)	L (8 bits)	H (8 bits)	L (8 bits)	(8 bits)	H03 (8 bits)	H (8 bits)	L (8 bits)	H (8 bits)	L (8 bits)

- Normal response (Response message)

a. Transaction identifier		b. Protocol identifier		c. Length field		d. Unit identifier	e. Function code	h. Byte count	i. Register value		
H (8 bits)	L (8 bits)	H (8 bits)	L (8 bits)	H (8 bits)	L (8 bits)	(8 bits)	H03 (8 bits)	(8 bits)	H (8 bits)	L (8 bits)	... (n × 16 bits)

- Query message setting

Message		Description
a	Transaction identifier	The client adds the data for the purpose of transaction control. The same data is returned in the response from the server.
b	Protocol identifier	Fixed to 0. (When the server receives data other than 0, it does not send the response message.) "0" is returned in the response from the server.
c	Length field	The data length from the unit identifier to the data is stored in byte.
d	Unit identifier	0, 255
e	Function code	Set H03.
f	Starting address	Set the holding register address from which to start reading the data. Starting address = start register address (decimal) - 40001 (Except for the CiA402 drive profile) For example, when starting address 0001 is set, the data of holding register address 40002 is read.
g	Quantity of registers	Set the number of holding registers for reading data. Data can be read from up to 125 registers.

- Content of normal response

Message		Description
h	Byte count	The setting range is H02 to HFA (2 to 250). Twice the number of reads specified by (g) is set.
i	Register value	The amount of data specified by (g) is set. Read data is output Hi bytes first followed by Lo bytes, and is arranged as follows: data of start address, data of start address+1, data of start address+2, and so forth.

■ Example) Read the register values of 41004 (Pr.4) to 41006 (Pr.6) from the inverter.

Query message

Transaction identifier		Protocol identifier		Length field		Unit identifier	Function code	Starting address		Quantity of registers	
*1	*1	H00 (8 bits)	H00 (8 bits)	H00 (8 bits)	H06 (8 bits)	HFF (8 bits)	H03 (8 bits)	H03 (8 bits)	HEB (8 bits)	H00 (8 bits)	H03 (8 bits)

*1 A given value is set.

Normal response (Response message)

Transaction identifier		Protocol identifier		Length field		Unit identifier	Function code	Byte count	Register value					
*1	*1	H00 (8 bits)	H00 (8 bits)	H00 (8 bits)	H09 (8 bits)	HFF (8 bits)	H03 (8 bits)	H06 (8 bits)	H17 (8 bits)	H70 (8 bits)	H0B (8 bits)	HB8 (8 bits)	H03 (8 bits)	HE8 (8 bits)

*1 The values are the same as those in the query message.

Read value

Register 41004 (Pr.4): H1770 (60.00 Hz)

Register 41005 (Pr.5): H0BB8 (30.00 Hz)

Register 41006 (Pr.6): H03E8 (10.00 Hz)

◆ Write single register (writing data to holding registers) (H06 or 06)

- The content of the system environmental variables and inverter parameters (refer to page 100) assigned to the holding register area can be written.
- Query message

a. Transaction identifier		b. Protocol identifier		c. Length field		d. Unit identifier	e. Function code	f. Register Address		g. Register value	
H (8 bits)	L (8 bits)	H (8 bits)	L (8 bits)	H (8 bits)	L (8 bits)	(8 bits)	H06 (8 bits)	H (8 bits)	L (8 bits)	H (8 bits)	L (8 bits)

- Normal response (Response message)

a. Transaction identifier		b. Protocol identifier		c. Length field		d. Unit identifier	e. Function code	f. Register Address		g. Register value	
H (8 bits)	L (8 bits)	H (8 bits)	L (8 bits)	H (8 bits)	L (8 bits)	(8 bits)	H06 (8 bits)	H (8 bits)	L (8 bits)	H (8 bits)	L (8 bits)

- Query message setting

Message		Description
a	Transaction identifier	The client adds the data for the purpose of transaction control. The same data is returned in the response from the server.
b	Protocol identifier	Fixed to 0. (When the server receives data other than 0, it does not send the response message.) "0" is returned in the response from the server.
c	Length field	The data length from the unit identifier to the data is stored in byte.
d	Unit identifier	0, 255
e	Function code	Set H06.
f	Register address	Set the holding register address to write data to. Register address = holding register address (decimal) - 40001 For example, when register address 0001 is set, data is written to holding register address 40002.
g	Register value	Set the data to write to the holding register. Write data is fixed at 2 bytes.

- Content of normal response

With a normal response, the contents in the response are the same as those in (a) to (g) of the query message.

■ Example) Write 60 Hz (H1770) to register 40014 (running frequency RAM) in the inverter.

Query message

Transaction identifier		Protocol identifier		Length field		Unit identifier	Function code	Register address		Register value	
*1	*1	H00 (8 bits)	H00 (8 bits)	H00 (8 bits)	H06 (8 bits)	HFF (8 bits)	H06 (8 bits)	H00 (8 bits)	H0D (8 bits)	H17 (8 bits)	H70 (8 bits)

*1 A given value is set.

Normal response (Response message)

The same data as those in the query message

◆ Diagnostics (diagnosis of functions) (H08 or 08)

- A communication check can be made since the query message is sent and the query message is returned as it is as the return message (subfunction code H00 function).
Subfunction code H00 (Return query data)
- Query message

a. Transaction identifier		b. Protocol identifier		c. Length field		d. Unit identifier	e. Function code	f. Sub-function		g. Data	
H (8 bits)	L (8 bits)	H (8 bits)	L (8 bits)	H (8 bits)	L (8 bits)	(8 bits)	H08 (8 bits)	H00 (8 bits)	H00 (8 bits)	H (8 bits)	L (8 bits)

- Normal response (Response message)

a. Transaction identifier		b. Protocol identifier		c. Length field		d. Unit identifier	e. Function code	f. Sub-function		g. Data	
H (8 bits)	L (8 bits)	H (8 bits)	L (8 bits)	H (8 bits)	L (8 bits)	(8 bits)	H08 (8 bits)	H00 (8 bits)	H00 (8 bits)	H (8 bits)	L (8 bits)

- Query message setting

Message		Description
a	Transaction identifier	The client adds the data for the purpose of transaction control. The same data is returned in the response from the server.
b	Protocol identifier	Fixed to 0. (When the server receives data other than 0, it does not send the response message.) "0" is returned in the response from the server.
c	Length field	The data length from the unit identifier to the data is stored in byte.
d	Unit identifier	0, 255
e	Function code	Set H08.
f	Sub-function	Set H0000.
g	Data	Any 2-byte long data can be set. The setting range is H0000 to HFFFF.

- Content of normal response

With a normal response, the contents in the response are the same as those in (a) to (g) of the query message.

◆ Write multiple registers (writing data to multiple holding registers) (H10 or 16)

- Data can be written to multiple holding registers.
- Query message

a. Transaction identifier		b. Protocol identifier		c. Length field		d. Unit identifier	e. Function code	f. Starting address		g. Quantity of registers		h. Byte count
H (8 bits)	L (8 bits)	H (8 bits)	L (8 bits)	H (8 bits)	L (8 bits)	(8 bits)	H10 (8 bits)	H (8 bits)	L (8 bits)	H (8 bits)	L (8 bits)	(8 bits)

i. Register value		
H (8 bits)	L (8 bits)	... (n × 2 × 8 bits)

- Normal response (Response message)

a. Transaction identifier		b. Protocol identifier		c. Length field		d. Unit identifier	e. Function code	f. Starting address		g. Quantity of registers	
H (8 bits)	L (8 bits)	H (8 bits)	L (8 bits)	H (8 bits)	L (8 bits)	(8 bits)	H10 (8 bits)	H (8 bits)	L (8 bits)	H (8 bits)	L (8 bits)

- Query message setting

Message		Description
a	Transaction identifier	The client adds the data for the purpose of transaction control. The same data is returned in the response from the server.
b	Protocol identifier	Fixed to 0. (When the server receives data other than 0, it does not send the response message.) "0" is returned in the response from the server.
c	Length field	The data length from the unit identifier to the data is stored in byte.
d	Unit identifier	0, 255
e	Function code	Set H10.
f	Starting address	Set the holding register address from which to start writing the data. Starting address = start register address (decimal) - 40001 (Except for the CiA402 drive profile) For example, when starting address 0001 is set, data is written to holding register 40002.
g	Quantity of registers	Set the number of holding registers for writing data. Data can be written to up to 125 registers.
h	Byte count	The setting range is H02 to HFA (2 to 250). Set the value set in (g) multiplied by 2.
i	Register value	The amount of data specified by (g) is set. Write data is output Hi bytes first followed by Lo bytes, and is arranged as follows: data of start address, data of start address+1, data of start address+2, and so forth.

- Content of normal response

With a normal response, the contents in the response are the same as those in (a) to (g) of the query message.

■ Example) Write 0.5 s (H05) to register 41007 (Pr.7) and 1 s (H0A) to register 41008 (Pr.8) in the inverter.

Query message

Transaction identifier		Protocol identifier		Length field		Unit identifier	Function code	Starting address		Quantity of registers		Byte count
*1	*1	H00 (8 bits)	H00 (8 bits)	H00 (8 bits)	H0B (8 bits)	HFF (8 bits)	H10 (8 bits)	H03 (8 bits)	HEE (8 bits)	H00 (8 bits)	H02 (8 bits)	H04 (8 bits)

Register value			
H00 (8 bits)	H05 (8 bits)	H00 (8 bits)	H0A (8 bits)

*1 A given value is set.

Normal response (Response message)

Transaction identifier		Protocol identifier		Length field		Unit identifier	Function code	Starting address		Quantity of registers	
*1	*1	H00 (8 bits)	H00 (8 bits)	H00 (8 bits)	H06 (8 bits)	HFF (8 bits)	H10 (8 bits)	H03 (8 bits)	HEE (8 bits)	H00 (8 bits)	H02 (8 bits)

*1 The values are the same as those in the query message.

◆ Read holding register access log (H46 or 70)

- Queries by function codes H03, H06, and H10 are supported.
The number and start address of holding registers successfully accessed by the previous communication are returned.
"0" is returned for both the number and start address for queries other than the function codes above.
- Query message

a. Transaction identifier		b. Protocol identifier		c. Length field		d. Unit identifier	e. Function code
H (8 bits)	L (8 bits)	H (8 bits)	L (8 bits)	H (8 bits)	L (8 bits)	(8 bits)	H46 (8 bits)

- Normal response (Response message)

a. Transaction identifier		b. Protocol identifier		c. Length field		d. Unit identifier	e. Function code	f. Starting address		g. No. of Points	
H (8 bits)	L (8 bits)	H (8 bits)	L (8 bits)	H (8 bits)	L (8 bits)	(8 bits)	H46 (8 bits)	H (8 bits)	L (8 bits)	H (8 bits)	L (8 bits)

- Query message setting

Message		Description
a	Transaction identifier	The client adds the data for the purpose of transaction control. The same data is returned in the response from the server.
b	Protocol identifier	Fixed to 0. (When the server receives data other than 0, it does not send the response message.) "0" is returned in the response from the server.
c	Length field	The data length from the unit identifier to the data is stored in byte.
d	Unit identifier	0, 255
e	Function code	Set H46.

- Content of normal response

Message		Description
f	Starting address	The start address of the holding register that was successfully accessed is returned. Starting address = start register address (decimal) - 40001 For example, when starting address 0001 is returned, the holding register address that was successfully accessed is 40002.
g	No. of points	The number of holding registers that were successfully accessed is returned.

■ Example) Read the successful register start address and the number of successful accesses from the inverter.

Query message

Transaction identifier		Protocol identifier		Length field		Unit identifier	Function code
*1	*1	H00 (8 bits)	H00 (8 bits)	H00 (8 bits)	H02 (8 bits)	HFF (8 bits)	H46 (8 bits)

*1 A given value is set.

Normal response (Response message)

Transaction identifier		Protocol identifier		Length field		Unit identifier	Function code	Starting address		No. of points	
*1	*1	H00 (8 bits)	H00 (8 bits)	H00 (8 bits)	H06 (8 bits)	HFF (8 bits)	H10 (8 bits)	H03 (8 bits)	HEE (8 bits)	H00 (8 bits)	H02 (8 bits)

*1 The values are the same as those in the query message.

The number of holding registers that were successfully accessed was returned as two with the start address 41007 (Pr.7).

◆ CiA402 drive profile

- Reading and writing according to the CiA402 drive profile are available.
- Use the function code H03 (page 94) for reading and the function code H10 (page 96) for writing.

■ Example) Read the register values of vl velocity acceleration (index 24648, sub index 0 to 2)

Query message

Transaction identifier		Protocol identifier		Length field		Unit identifier	Function code	Starting address		Quantity of registers	
*1	*1	H00 (8 bits)	H00 (8 bits)	H00 (8 bits)	H06 (8 bits)	HFF (8 bits)	H03 (8 bits)	H60 (8 bits)	H48 (8 bits)	H00 (8 bits)	H04 (8 bits)

*1 A given value is set.

Normal response (Response message)

Transaction identifier		Protocol identifier		Length field		Unit identifier	Function code	Byte count
*1	*1	H00 (8 bits)	H00 (8 bits)	H00 (8 bits)	H0A (8 bits)	HFF (8 bits)	H03 (8 bits)	H08 (8 bits)

Register value							
H00 (8 bits)	H02 (8 bits)	H07 (8 bits)	H08 (8 bits)	H00 (8 bits)	H00 (8 bits)	H00 (8 bits)	H05 (8 bits)

*1 The values are the same as those in the query message.

Read value

Sub index 0 (Highest sub-index supported): H0002 (2)

Sub index 1 (Delta speed): H07080000 (1800 r/min)

Sub index 2 (Delta time): H0005 (0.5 s)

■ Example) Write the register values to vl velocity acceleration (index 24648, sub index 0 to 2)

Query message

Transaction identifier		Protocol identifier		Length field		Unit identifier	Function code	Starting address		Quantity of registers		Byte count
*1	*1	H00 (8 bits)	H00 (8 bits)	H00 (8 bits)	H0F (8 bits)	HFF (8 bits)	H10 (8 bits)	H60 (8 bits)	H48 (8 bits)	H00 (8 bits)	H04 (8 bits)	H08 (8 bits)

Register value							
H00 (8 bits)	H02 (8 bits)	H07 (8 bits)	H08 (8 bits)	H00 (8 bits)	H00 (8 bits)	H00 (8 bits)	H05 (8 bits)

*1 A given value is set.

Normal response (Response message)

Transaction identifier		Protocol identifier		Length field		Unit identifier	Function code	Starting address		Quantity of registers	
*1	*1	H00 (8 bits)	H00 (8 bits)	H00 (8 bits)	H06 (8 bits)	HFF (8 bits)	H10 (8 bits)	H60 (8 bits)	H48 (8 bits)	H00 (8 bits)	H04 (8 bits)

*1 The values are the same as those in the query message.

◆ Error response

- An error response is returned if the query message received from the client contains an illegal function, address or data.

- Error response (Response message)

a. Transaction identifier		b. Protocol identifier		c. Length field		d. Unit identifier	e. Function code	f. Exception code
H (8 bits)	L (8 bits)	H (8 bits)	L (8 bits)	H (8 bits)	L (8 bits)	(8 bits)	H80 + Function (8 bits)	(8 bits)

Message		Description
a	Transaction identifier	The client adds the data for the purpose of transaction control. The same data is returned in the response from the server.
b	Protocol identifier	Fixed to 0. (When the server receives data other than 0, it does not send the response message.) "0" is returned in the response from the server.
c	Length field	The data length from the unit identifier to the data is stored in byte.
d	Unit identifier	0, 255
e	Function code	The function code requested by the client and H80 is set.
f	Exception code	The codes in the following table are set.

- Error code list

Code	Error item	Error description
01	ILLEGAL FUNCTION	The query message from the client has a function code that cannot be handled by the server.
02	ILLEGAL DATA ADDRESS	<ul style="list-style-type: none"> • The query message from the client has a register address that cannot be handled by the server. (No parameter, parameter cannot be read, parameter cannot be written) (Except for the CiA402 drive profile)^{*1} • A nonexistent holding register is accessed using the CiA402 drive profile. More than one holding register with more than one subindex is accessed.^{*2*3}
03	ILLEGAL DATA VALUE	The query message from the client has data that cannot be handled by the server. (Out of parameter write range, a mode is specified, or some other error) ^{*1}
06	SERVER DEVICE BUSY	The request message cannot be processed because the server is executing another operation.

*1 An error response is not returned in the following cases.

In other words, when function code H03 or H10 is used and multiple holding registers are accessed, an error response is not returned even if a nonexistent holding register or holding register that cannot be read or written from/to is accessed.

An error response is returned if none of the accessed holding registers exist. When an accessed holding register does not exist, the read value is 0 and the written data is invalid.

(a) Function code H03 (reading data of holding registers)

When the quantity of registers is specified as one or more and there are one or more holding registers from which data can be read.

(b) Function code H10 (writing data to multiple holding registers)

When the quantity of registers is specified as one or more and there are one or more holding registers to which data can be written.

*2 An error response is returned in the following cases.

Example	Index	Sub index	Function code	
			H03	H10
Access is attempted to index 24644 to index 24646 (index 24645 does not exist).	24644 (H6044)	0	Error code H02	Error code H02
	24646 (H6046)	0		
Access is attempted to index 24648 and index 24649.	24648 (H6048)	0	Error code H02	Error code H02 The written data will be valid as far as subindex 2 of index 24648.
		1		
	2			
	24649 (H6049)	0		
Access is attempted to index 24728 and index 24729.	24728 (H6098)	0	Error code H02	Error code H02 The written data will be valid as far as subindex 0 of index 24728.
		1		
	2			
Access is attempted to index 24729 and index 24730.	24729 (H6099)	0	Error code H02	Error code H02 The written data will be valid as far as subindex 2 of index 24729.
		1		
	24730 (H609A)	0		

*3 An error response is not returned in the following cases.

Function code H10 (writing data to multiple holding registers)

Access is attempted to a writing-disabled subindex of a holding register with multiple subindices and data writing is enabled for at least one of the subindices.

◆ MODBUS register

- The following shows the MODBUS registers for system environment variables (read/write), monitor codes (read), parameters (read/write), fault history data (read/write), model information monitor items (read), and CiA402 drive profile data (read/write).
- System environment variables

Register	Definition	Read/write	Remarks
40002	Inverter reset	Write	Any value
40003	Parameter clear	Write	Set H965A.
40004	All parameter clear	Write	Set H99AA.
40006	Parameter clear ^{*1}	Write	Set H5A96.
40007	All parameter clear ^{*1}	Write	Set HAA99.
40008	Inverter status / control input command (extended) ^{*2}	Read/write	Refer to the following.
40009	Inverter status / control input command ^{*2}	Read/write	Refer to the following.
40010	Operation mode / inverter setting ^{*3}	Read/write	Refer to the following.
40014	Running frequency (RAM value)	Read/write	(The display can be changed to the rotations per minute (machine speed) using Pr.37 and Pr.53 . Refer to the FR-E800 Instruction Manual (Function).)
40015	Running frequency (EEPROM value)	Write	

*1 Settings in the communication parameters are not cleared.

*2 The data is written as a control input command for writing.
The data is read as the inverter status for reading.

*3 The data is written as an operation mode setting for writing.
The data is read as the operation mode status for reading.

- Inverter status / control input command, and inverter status / control input command (extended)

Bit	Definition	
	Control input command	Inverter status
0	Stop command	RUN (Inverter running) ^{*2}
1	Forward rotation command	Forward running
2	Reverse rotation command	Reverse running
3	RH (High-speed operation command) ^{*1}	Up to frequency
4	RM (Middle-speed operation command) ^{*1}	Overload warning
5	RL (Low-speed operation command) ^{*1}	0
6	JOG operation selection 2	FU (Output frequency detection) ^{*2}
7	Second function selection	ABC (Fault) ^{*2}
8	Terminal 4 input selection	ABC2 (0) ^{*2}
9	—	Safety monitor output 2
10	MRS (Output stop) ^{*1}	0
11	—	0
12	RES (—) ^{*1}	0
13	—	0
14	—	0
15	—	Fault occurrence

Bit	Definition	
	Control input command	Inverter status
0	NET X1 (—) ^{*1}	NET Y1 (0) ^{*2}
1	NET X2 (—) ^{*1}	NET Y2 (0) ^{*2}
2	NET X3 (—) ^{*1}	NET Y3 (0) ^{*2}
3	NET X4 (—) ^{*1}	NET Y4 (0) ^{*2}
4	NET X5 (—) ^{*1}	0
5	—	0
6	—	0
7	—	0
8	—	0
9	—	0
10	—	0
11	—	0
12	—	0
13	—	0
14	—	0
15	—	0

*1 The signal within parentheses () is the initial status. The function changes depending on the setting of **Pr.180 to Pr.189 (Input terminal function selection)**.

For details, refer to the description of **Pr.180 to Pr.189 (Input terminal function selection)** in the FR-E800 Instruction Manual (Function).
The signals assigned to the input terminals may be valid or invalid in the NET operation mode. (Refer to the FR-E800 Instruction Manual (Function).)

*2 The signal within parentheses () is the initial status. The function changes depending on the setting of **Pr.190 to Pr.197 (Output terminal function selection)**.

For details, refer to the description of **Pr.190 to Pr.197 (Output terminal function selection)** in the FR-E800 Instruction Manual (Function).

- Operation mode / inverter setting

Mode	Read value	Write value
EXT	H0000	H0010 ^{*1}
PU	H0001	H0011 ^{*1}
EXT JOG	H0002	—
PU JOG	H0003	—
NET	H0004	H0014
PU + EXT	H0005	—

*1 Writing is available depending on the **Pr.79** and **Pr.340** settings. For details, refer to the FR-E800 Instruction Manual (Function). Restrictions in each operation mode conform with the computer link specification.

- Monitor code

For details of the register numbers and the monitor items, refer to the description of **Pr.52** in the FR-E800 Instruction Manual (Function).

- Parameter

Pr.	Register	Name	Read/write	Remarks
0 to 999	41000 to 41999	For details on parameter names, refer to the parameter list in the FR-E800 Instruction Manual (Function).	Read/write	The parameter number + 41000 is the register number.
C2 (902)	41902	Terminal 2 frequency setting bias frequency	Read/write	
C3 (902)	42092	Terminal 2 frequency setting bias (analog value)	Read/write	Analog value (%) set in C3 (902)
	43902	Terminal 2 frequency setting bias (terminal analog value)	Read	Analog value (%) of the voltage (current) applied to terminal 2
125 (903)	41903	Terminal 2 frequency setting gain frequency	Read/write	
C4 (903)	42093	Terminal 2 frequency setting gain (analog value)	Read/write	Analog value (%) set in C4 (903)
	43903	Terminal 2 frequency setting gain (terminal analog value)	Read	Analog value (%) of the voltage (current) applied to terminal 2
C5 (904)	41904	Terminal 4 frequency setting bias frequency	Read/write	
C6 (904)	42094	Terminal 4 frequency setting bias (analog value)	Read/write	Analog value (%) set in C6 (904)
	43904	Terminal 4 frequency setting bias (terminal analog value)	Read	Analog value (%) of the current (voltage) applied to terminal 4
126 (905)	41905	Terminal 4 frequency setting gain frequency	Read/write	
C7 (905)	42095	Terminal 4 frequency setting gain (analog value)	Read/write	Analog value (%) set in C7 (905)
	43905	Terminal 4 frequency setting gain (terminal analog value)	Read	Analog value (%) of the current (voltage) applied to terminal 4
C12 (917)	41917	Terminal 1 bias frequency (speed)	Read/write	Available only when the FR-E8AXY is installed.
C13 (917)	42107	Terminal 1 bias (speed) (analog value)	Read/write	Analog value (%) set in C13 (917) (Available only when the FR-E8AXY is installed.)
	43917	Terminal 1 bias (speed) (terminal analog value)	Read	Analog value (%) of the voltage applied to terminal 1 (Available only when the FR-E8AXY is installed.)
C14 (918)	41918	Terminal 1 gain frequency (speed)	Read/write	Available only when the FR-E8AXY is installed.
C15 (918)	42108	Terminal 1 gain (speed) (analog value)	Read/write	Analog value (%) set in C15 (918) (Available only when the FR-E8AXY is installed.)
	43918	Terminal 1 gain (speed) (terminal analog value)	Read	Analog value (%) of the voltage applied to terminal 1 (Available only when the FR-E8AXY is installed.)
C16 (919)	41919	Terminal 1 bias command (torque)	Read/write	Available only when the FR-E8AXY is installed.
C17 (919)	42109	Terminal 1 bias (torque) (analog value)	Read/write	Analog value (%) set in C17 (919) (Available only when the FR-E8AXY is installed.)
	43919	Terminal 1 bias (torque) (terminal analog value)	Read	Analog value (%) of the voltage applied to terminal 1 (Available only when the FR-E8AXY is installed.)
C18 (920)	41920	Terminal 1 gain command (torque)	Read/write	Available only when the FR-E8AXY is installed.

Pr.	Register	Name	Read/write	Remarks
C19 (920)	42110	Terminal 1 gain (torque) (analog value)	Read/write	Analog value (%) set in C19 (920) (Available only when the FR-E8AXY is installed.)
	43920	Terminal 1 gain (torque) (terminal analog value)	Read	Analog value (%) of the voltage applied to terminal 1 (Available only when the FR-E8AXY is installed.)
C38 (932)	41932	Terminal 4 bias command (torque)	Read/write	
C39 (932)	42122	Terminal 4 bias (torque) (analog value)	Read/write	Analog value (%) set in C39 (932)
	43932	Terminal 4 bias (torque) (terminal analog value)	Read	Analog value (%) of the current (voltage) applied to terminal 4
C40 (933)	41933	Terminal 4 gain command (torque)	Read/write	
C41 (933)	42123	Terminal 4 gain (torque) (analog value)	Read/write	Analog value (%) set in C41 (933)
	43933	Terminal 4 gain (torque) (terminal analog value)	Read	Analog value (%) of the current (voltage) applied to terminal 4
C42 (934)	41934	PID display bias coefficient	Read/write	
C43 (934)	42124	PID display bias analog value	Read/write	Analog value (%) set in C43 (934)
	43934	PID display bias analog value (terminal analog value)	Read	Analog value (%) of the current (voltage) applied to terminal 4
C44 (935)	41935	PID display gain coefficient	Read/write	
C45 (935)	42125	PID display gain analog value	Read/write	Analog value (%) set in C45 (935)
	43935	PID display gain analog value (terminal analog value)	Read	Analog value (%) of the current (voltage) applied to terminal 4
1000 to 1999	45000 to 45999	For details on parameter names, refer to the parameter list in the FR-E800 Instruction Manual (Function).	Read/write	The parameter number + 44000 is the register number.

- Fault history

Register	Definition	Read/write	Remarks
40501	Fault record 1	Read/write	<p>Being 2 bytes in length, the data is stored as H00○○.</p> <p>Refer to the lowest 1 byte for the error code. (For details on error codes, refer to the list of fault displays in the FR-E800 Instruction Manual (Maintenance).)</p> <p>The fault history is batch-cleared by writing to register 40501.</p> <p>Set any value as data.</p>
40502	Fault record 2	Read	
40503	Fault record 3	Read	
40504	Fault record 4	Read	
40505	Fault record 5	Read	
40506	Fault record 6	Read	
40507	Fault record 7	Read	
40508	Fault record 8	Read	
40509	Fault record 9	Read	
40510	Fault record 10	Read	

- Product profile

Register	Definition	Read/write	Remarks
44001	Model (1st and 2nd characters)	Read	<p>The model name can be read in ASCII code.</p> <p>"H20" (blank code) is set for blank area.</p> <p>Example) FR-E820-EPA: H46, H52, H2D, H45, H38, H32, H30, H2D, H45, H50, H41, H20...H20</p>
44002	Model (3rd and 4th characters)	Read	
44003	Model (5th and 6th characters)	Read	
44004	Model (7th and 8th characters)	Read	
44005	Model (9th and 10th characters)	Read	
44006	Model (11th and 12th characters)	Read	
44007	Model (13th and 14th characters)	Read	
44008	Model (15th and 16th characters)	Read	
44009	Model (17th and 18th characters)	Read	
44010	Model (19th and 20th characters)	Read	
44011	Capacity (1st and 2nd characters)	Read	<p>The capacity in the inverter model can be read in ASCII code.</p> <p>Data read is displayed in increments of 0.1 kW (rounded down to one decimal place).</p> <p>"H20" (blank code) is set for blank area.</p> <p>Example) 0.75K: " 7" (H20, H20, H20, H20, H20, H37)</p>
44012	Capacity (3rd and 4th characters)	Read	
44013	Capacity (5th and 6th characters)	Read	

NOTE

- When a 32-bit parameter setting or monitor item is read and the value to be read exceeds HFFFF, HFFFF is returned.
- The display can be changed from the frequency to rotations per minute (machine speed) using **Pr.53**. When the machine speed is displayed, the value is incremented by one.

- CiA402 drive profile

Register		Name	Description	Read/write	Data type
Index	Sub index				
24639 (H603F)	0	Error code	Error number The error code of the latest fault that occurred after power-ON or an inverter reset is returned. When no fault occurs, no error is returned. When the fault history is cleared during occurrence of a fault, no error is returned. The upper eight bits are fixed to FF, and the lower eight bits represent the error code. (HFFXX: "XX" represents the error code.) (For details on error codes, refer to the list of fault displays in the Instruction Manual (Maintenance).)	Read	Unsigned16
24642 (H6042)	0	vl target velocity	Set speed (r/min) ^{*1*3} Set the set frequency in r/min. Monitoring range: -32768 (H8000) to 32767 (H7FFF) When Pr.81 = "9999", the number of motor poles is regarded as 4. Do not change the settings of this index and index 24831 (H60FF) at the same time.	Read/write	Integer16
24643 (H6043)	0	vl velocity demand	Output frequency (r/min) ^{*1} The output frequency is read in r/min. Monitoring range: -32768 (H8000) to 32767 (H7FFF) When Pr.81 = "9999", the number of motor poles is regarded as 4.	Read	Integer16
24644 (H6044)	0	vl velocity actual value	Operation speed (r/min) ^{*1} The operation speed is read in r/min. Monitoring range: -32768 (H8000) to 32767 (H7FFF) When Pr.81 = "9999", the number of motor poles is regarded as 4.	Read	Integer16
24646 (H6046)	—	vl velocity min max amount	Minimum/maximum speed (r/min)	—	—
	0	Highest sub-index supported	Maximum value of subindex: H02 (fixed)	Read	Unsigned8
	1	vl velocity min amount	Minimum speed (r/min) ^{*1*2} Set Pr.2 Minimum frequency in r/min. Setting range: 0 to 120 Hz	Read/write	Unsigned32
	2	vl velocity max amount	Maximum speed (r/min) ^{*1*2} Set Pr.18 High speed maximum frequency in r/min. Setting range: 0 to 590 Hz Do not change the settings of this index and index 24703 (H607F) at the same time.	Read/write	Unsigned32
24648 (H6048)	—	vl velocity acceleration	Acceleration vl velocity acceleration = Delta speed/Delta time	—	—
	0	Highest sub-index supported	Maximum value of subindex: H02 (fixed)	Read	Unsigned8
	1	Delta speed	Reference speed (r/min) ^{*1*2} Set Pr.20 Acceleration/deceleration reference frequency in r/min. Setting range: 1 to 590 Hz	Read/write	Unsigned32
	2	Delta time	Acceleration time (s) ^{*2} Set Pr.7 Acceleration time . Setting range: 0 to 3600 s (Example: To accelerate to 1500 r/min for 3.7 seconds, set sub index 1 to 15000 r/min and set sub index 2 to 37 seconds.) Do not change the settings of this index and index 24707 (H6083) at the same time.	Read/write	Unsigned16

Register		Name	Description	Read/write	Data type
Index	Sub index				
24649 (H6049)	—	vI velocity deceleration	Deceleration vI velocity deceleration = Delta speed/Delta time	—	—
	0	Highest sub-index supported	Maximum value of subindex: H02 (fixed)	Read	Unsigned8
	1	Delta speed	Reference speed (r/min) ^{*1*2} Set Pr.20 Acceleration/deceleration reference frequency in r/min. Setting range: 1 to 590 Hz	Read/write	Unsigned32
	2	Delta time	Deceleration time (s) ^{*2} Set Pr.8 Deceleration time . Setting range: 0 to 3600 s (Example: To decelerate from 1500 r/min for 3.7 seconds, set sub index 1 to 15000 r/min and set sub index 2 to 37 seconds.) Do not change the settings of this index and index 24708 (H6084) at the same time.	Read/write	Unsigned16
24672 (H6060)	0	Modes of operation	Control mode: -1 (vendor specific operation mode) (fixed)	Read/write	Integer8
24673 (H6061)	0	Modes of operation display	Current control mode: -1 (vendor specific operation mode) (fixed)	Read	Integer8
24674 (H6062)	0	Position demand value	Position command (pulse) The position command before the electronic gear operation is read.	Read	Integer32
24675 (H6063)	0	Position actual internal value	Current position (pulse) The current position after the electronic gear operation is read.	Read	Integer32
24676 (H6064)	0	Position actual value	Current position (pulse) The current position before the electronic gear operation is read.	Read	Integer32
24689 (H6071)	0	Target torque	Target torque (%) Set Pr.805 Torque command value (RAM) . Setting range: 600% to 1400% When the value is set in 0.1 increments, the first decimal place is rounded off.	Read/write	Integer16
24692 (H6074)	0	Torque demand	Torque demand value (%) The torque command is read.	Read	Integer16
24695 (H6077)	0	Torque actual value	Torque actual value (%) The motor torque is read.	Read	Integer16
24698 (H607A)	0	Target position	Target position (pulse) Set the target position in the direct command mode. Initial value: 0 Setting range: -2147483647 to 2147483647 (For the direct command mode, refer to the FR-E800 Instruction Manual (Function).)	Read/write	Integer32
24703 (H607F)	0	Max profile velocity	Maximum profile speed (r/min) ^{*1*2} Set Pr.18 High speed maximum frequency in r/min. Setting range: 0 to 590 Hz Do not change the settings of this index and index 24646 (H6046), sub index 2 at the same time.	Read/write	Unsigned32
24705 (H6081)	0	Profile velocity	Profile speed (r/min) Set the maximum speed in the direct command mode. Initial value: 0 Setting range: 0 to (120 × 590 Hz / Pr.81) (For the direct command mode, refer to the FR-E800 Instruction Manual (Function).)	Read/write	Unsigned32

Register		Name	Description	Read/write	Data type
Index	Sub index				
24707 (H6083)	0	Profile acceleration	Acceleration time constant (ms) <Position control> Set the acceleration time in the direct command mode. Initial value: 5000 Setting range: 10 to 360000 The last digit is rounded off. (For example, 1358 ms becomes 1350 ms.) (For the direct command mode, refer to the FR-E800 Instruction Manual (Function).) <Other than position control> Set Pr.7 Acceleration time in ms. Setting range: 0 to 3600 s The last two digits are rounded off when Pr.21 Acceleration/ deceleration time increments = "0", and the last digit is rounded off when Pr.21 = "1". Do not change the settings of this index and index 24648 (H6048), sub index 2 at the same time.	Read/write	Unsigned32
24708 (H6084)	0	Profile deceleration	Deceleration time constant (ms) <Position control> Set the deceleration time in the direct command mode. Initial value: 5000 Setting range: 10 to 360000 The last digit is rounded off. (For example, 1358 ms becomes 1350 ms.) (For the direct command mode, refer to the FR-E800 Instruction Manual (Function).) <Other than position control> Set Pr.8 Deceleration time in ms. Setting range: 0 to 3600 s The last two digits are rounded off when Pr.21 Acceleration/ deceleration time increments = "0", and the last digit is rounded off when Pr.21 = "1". Do not change the settings of this index and index 24649 (H6049), sub index 2 at the same time.	Read/write	Unsigned32
24719 (H608F)	—	Position encoder resolution	Encoder resolution (machine side / motor side)	—	—
	0	Highest sub-index supported	Maximum value of subindex: H02 (fixed)	Read	Unsigned8
	1	Encoder increments	Encoder resolution Set Pr.369 Number of encoder pulses . Setting range: 2 to 4096	Read/write	Unsigned32
	2	Motor revolutions	Motor speed (rev): H00000001 (fixed)	Read/write	Unsigned32
24721 (H6091)	—	Gear ratio	Gear ratio	—	—
	0	Highest sub-index supported	Maximum value of subindex: H02 (fixed)	Read	Unsigned8
	1	Motor revolutions	Motor shaft revolutions ^{*2} Set Pr.420 Command pulse scaling factor numerator (electronic gear numerator) . Setting range: 1 to 32767	Read/write	Unsigned32
	2	Shaft revolutions	Drive shaft revolutions ^{*2} Set Pr.421 Command pulse multiplication denominator (electronic gear denominator) . Setting range: 1 to 32767	Read/write	Unsigned32
24728 (H6098)	0	Homing method	Home position return method Set the home position return method in the direct command mode. ^{*4} (For the direct command mode and the home position return method, refer to the FR-E800 Instruction Manual (Function).)	Read/write	Integer8

Register		Name	Description	Read/write	Data type
Index	Sub index				
24729 (H6099)	—	Homing speeds	Home position return speed	—	—
	0	Highest sub-index supported	Maximum value of subindex: H01 (fixed)	Read	Unsigned8
	1	Speed during search for switch	Motor speed during home position returning (r/min) Set the home position return speed in the direct command mode. Initial value: 120 × 2 Hz / Pr.81 Setting range: 0 to (120 × 400 Hz / Pr.81) (For the direct command mode, refer to the FR-E800 Instruction Manual (Function).)	Read/write	Unsigned32
24730 (H609A)	0	Homing acceleration	Home position return acceleration/deceleration time (ms) Set the home position return acceleration/deceleration time in the direct command mode. Initial value: 5000 Setting range: 10 to 360000 The last digit is rounded off. (For example, 1358 ms becomes 1350 ms.) (For the direct command mode, refer to the FR-E800 Instruction Manual (Function).)	Read/write	Unsigned32
24820 (H60F4)	0	Following error actual value	Droop pulse (pulse) The droop pulse before the electronic gear operation is read.	Read	Integer32
24826 (H60FA)	0	Control effort	Speed command after position loop ^{*1} The ideal speed command is read.	Read	Integer32
24828 (H60FC)	0	Position demand internal value	Position command (pulse) The position command after the electronic gear operation is read.	Read	Integer32
24831 (H60FF)	0	Target velocity	Set speed (r/min) ^{*1*3} Set the set frequency in r/min. Monitoring range: -32768 (H8000) to 32767 (H7FFF) When Pr.81 = "9999", the number of motor poles is regarded as 4. For writing the value after the unit switchover using Pr.53 , the lower 24 bits of the data are valid and the upper 8 bits are ignored. Do not change the settings of this index and index 24642 (H6042) at the same time.	Read/write	Integer32
25858 (H6502)	0	Supported drive modes	Supported control mode: H00010000 (vendor specific operation mode)	Read	Unsigned32
26623 (H67FF)	0	Single device type	Device type Bit 0 to 15 Device Profile Number: H0192 (402: Drive Profile) Bit 16 to 23 Additional Information (Type): H01 (Frequency Converter: inverter) Bit 24 to 31 Additional Information (mode bits): H00	Read	Unsigned32

*1 The value is displayed and set in r/min regardless of the settings in **Pr.53**.

The frequency is converted to the rotation speed for reading, and the setting value is converted to the frequency for writing.

*2 Writing to EEPROM or RAM is selected according to the setting in **Pr.342 Communication EEPROM write selection**.

*3 Writing is not restricted by the **Pr.18 and Pr.2** settings.

*4 The following table shows home position return methods corresponding to the Index 24728 (H6098) setting values.

24728 (H6098) setting	Home position return method
-3	Data set type
-4	Stopper type (home position return direction: position pulse increasing direction)
-5 (initial value)	Ignoring the home position (servo ON position as the home position)
-7	Count type with front end reference (home position return direction: position pulse increasing direction)
-36	Stopper type (home position return direction: position pulse decreasing direction)
-39	Count type with front end reference (home position return direction: position pulse decreasing direction)
-65	Stopper type (home position return direction: start command direction)
-66	Count type with front end reference (home position return direction: start command direction)

NOTE

- The command interface in the Network operation mode is determined by the **Pr.550 NET mode operation command source selection** setting. (Refer to the FR-E800 Instruction Manual (Function).)
- When the data is read, the value is displayed with a sign regardless of the **Pr.290 Monitor negative output selection** setting.

2.8 BACnet/IP

2.8.1 Outline

BACnet/IP is available for the FR-E800-(SC)EPA and FR-E806-SCEPA.

Operation or parameter setting via communication is possible using the BACnet/IP through the Ethernet connector on the inverter.

Some functions are not supported depending on the date of manufacture of the inverter. For details of specification changes, refer to [page 290](#).

◆ Communication specifications

The specifications conform to the BACnet standard of the Ethernet physical medium.

Item	Description
Physical medium	Ethernet (ISO 8802-3)
Supported property of BACnet standard object type	Refer to page 112 .
Supported BIBBs (Annex K)	Refer to page 120 .
BACnet standardized device profile (Annex L)	Refer to page 120 .
Segmentation	Not supported
Device address binding	Not supported
Topology	Line, star, or a combination of line and star

NOTE

- This product is classified as a BACnet Application Specific Controller (B-ASC).

2.8.2 Initial setting for BACnet/IP

Use the following parameters to perform required settings for Ethernet communication between the inverter and other devices. To make communication between other devices and the inverter, perform the initial settings of the inverter parameters to match the communication specifications of the devices. Data communication cannot be made if the initial settings are not configured or if there is any setting error.

Pr.	Name	Initial value	Setting range	Setting range
1427 N630 ^{*1}	Ethernet function selection 1	5001		Set the application, protocol, etc.
1428 N631 ^{*1}	Ethernet function selection 2	45237	502, 5000 to 5002, 5006 to 5008, 5010 to 5013, 9999, 44818, 45237, 45238, 47808, 61450	
1429 N632 ^{*1}	Ethernet function selection 3	45238		
1430 N633 ^{*1}	Ethernet function selection 4	9999		
1432 N644	Ethernet communication check time interval	1.5 s	0	Ethernet communication is available, but the inverter output is shut off in the NET operation mode.
			0.1 to 999.8 s	Set the interval of the communication check (signal loss detection) time for all devices with IP addresses in the range specified for Ethernet command source selection (Pr.1449 to Pr.1454). If a no-communication state persists for longer than the permissible time, the inverter output will be shut off.
			9999	No communication check (signal loss detection)

Pr.	Name	Initial value	Setting range	Setting range
1449 N670 ^{*1}	Ethernet command source selection IP address 1	0	0 to 255	To limit the network devices that send the operation or speed command through the Ethernet network, set the range of IP addresses of the devices. When Pr.1449 to Pr.1452 = "0 (initial value)", no IP address is specified for command source selection via Ethernet. In this case, operation commands cannot be sent via Ethernet with MODBUS/TCP protocol.
1450 N671 ^{*1}	Ethernet command source selection IP address 2	0		
1451 N672 ^{*1}	Ethernet command source selection IP address 3	0		
1452 N673 ^{*1}	Ethernet command source selection IP address 4	0		
1453 N674 ^{*1}	Ethernet command source selection IP address 3 range specification	9999	0 to 255, 9999	
1454 N675 ^{*1}	Ethernet command source selection IP address 4 range specification	9999		

*1 The setting is applied after an inverter reset or next power-ON.

NOTE

- The monitor items and parameter settings can be read during communication with the **Pr.1432 Ethernet communication check time interval** = "0 (initial value)" setting, but such operation will become faulty once the operation mode is changed to the NET operation mode. When the NET operation mode is selected as the start-up operation mode, communication is performed once, then an Ethernet communication fault (E.EHR) occurs.
To perform operation or parameter writing via communication, set **Pr.1432** to "9999" or a value larger than the communication cycle or retry time setting. (Refer to [page 109](#).)

◆ Ethernet function selection (Pr.1427 to Pr.1430)

To select BACnet/IP for the application, set "47808" (BACnet/IP) in any of **Pr.1427 to Pr.1430 Ethernet function selection 1 to 4**.

NOTE

- Change the setting if selected communication protocols cannot be used together. (Refer to [page 7](#) and [page 226](#).)

◆ Ethernet IP address for command source selection (Pr.1449 to Pr.1454)

- To limit the network devices that send the operation or speed command through the Ethernet network, set the range of IP addresses of the devices.
- When **Pr.1449 to Pr.1452** = "0 (initial value)", no IP address is specified for command source selection via Ethernet. In this case, operation commands cannot be sent via Ethernet.

- The setting range for command source selection depends on the settings in **Pr.1451** and **Pr.1453**, and **Pr.1452** and **Pr.1454**. (Either of the settings can be larger than the other in **Pr.1451** and **Pr.1453**, and **Pr.1452** and **Pr.1454**.)

[Setting example 1] Configuration

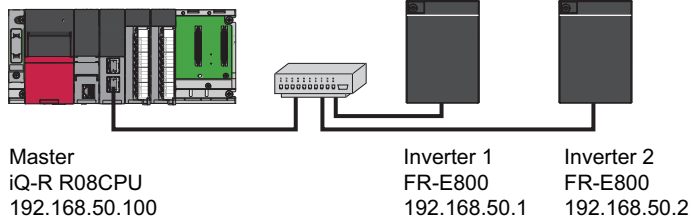

To allow the master to control the inverters, set the parameters in inverters 1 and 2 as follows to specify the IP address range for Ethernet command source selection.

Set the IP address of the master in the engineering software (GX Works3) within the range from 192.168.50.100 to 192.168.50.110.

	Pr.1449	Pr.1450	Pr.1451	Pr.1452
Ethernet IP address for command source selection	192	168	50	100
Command source selection range setting for the Ethernet IP address	—	—	9999	110

Pr.1453 Pr.1454

The range is between the values set in both parameters.

In this case, the IP address range in which Ethernet communication is permitted is "192.168.50.xxx (100 to 110)".

[Setting example 2]

	Pr.1449	Pr.1450	Pr.1451	Pr.1452
Ethernet IP address for command source selection	192	168	1	100
Command source selection range setting for the Ethernet IP address	—	—	3	150

Pr.1453 Pr.1454

The range is between the values set in both parameters.

The range is between the values set in both parameters.

In this case, the IP address range for command source selection via Ethernet communication is "192.168.x (1 to 3).xxx (100 to 150)".

- When "9999 (initial value)" is set in **Pr.1453** or **Pr.1454**, the range is invalid.

NOTE

- When BACnet/IP is used, do not include IP addresses of other inverters in the Ethernet IP address range set for command source selection. If an IP address of any other inverter falls within the range, the protective function (E.EHR) will be activated after the time period set in **Pr.1432** after power is supplied to the inverter.

◆ Ethernet communication check time interval (Pr.1432)

- If a signal loss (communication stop) is detected between the inverter and all the devices with IP addresses in the range for Ethernet command source selection (**Pr.1449 to Pr.1454**) as a result of a signal loss detection, a communication error (E.EHR) occurs and the inverter output will be shut off.
- When "9999" is set in **Pr.1432**, the communication check (signal loss detection) will not be performed.
- The monitor items and parameter settings can be read via Ethernet when "0" is set in **Pr.1432**, but a communication error (E.EHR) occurs instantly when the operation mode is switched to the Network operation.
- A signal loss detection is made when any of 0.1 s to 999.8 s is set in **Pr.1432**. In order to enable the signal loss detection, data must be sent by connected devices at an interval equal to or less than the time set for the communication check. (The inverter makes a communication check (clearing of communication check counter) regardless of the station number setting of the data sent from the master).

- Communication check is started at the first communication when the inverter operates in the Network operation mode and the command source is specified as communication via the Ethernet connector.

Example) When Pr.1432 = 0.1 to 999.8 s

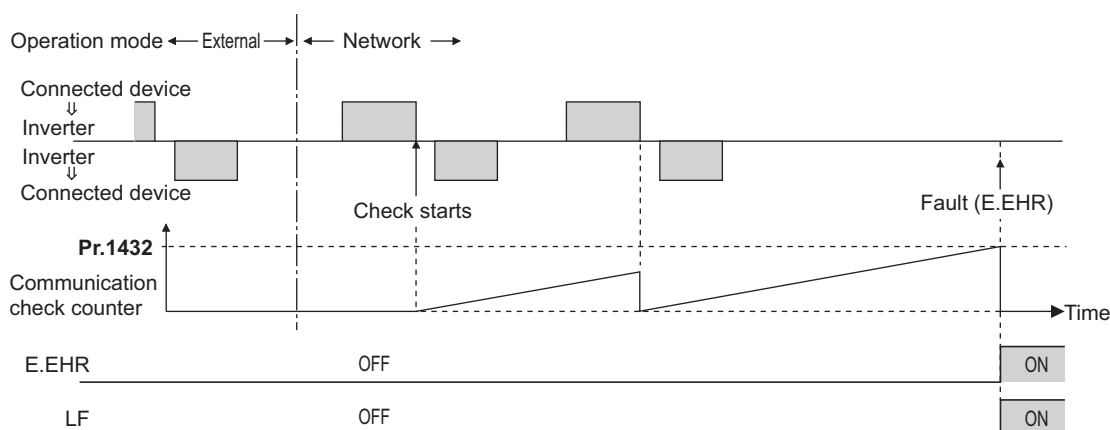

2.8.3 Parameters related to BACnet/IP

The following parameters are used for BACnet/IP communication. Set the parameters as required.

Pr.	Name	Initial value	Setting range	Description
390 N054	% setting reference frequency	60 Hz	1 to 590 Hz	Set a reference frequency of the set frequency.
728 N052	Device instance number (Upper 3 digits)	0	0 to 419 (0 to 418)	Device identifier When the figure obtained by combining the Pr.728 and Pr.729 settings is not within "0 to 4194302", the setting is out of range. (The setting range of Pr.729 is "0 to 4302" when Pr.728 = "419". The setting range of Pr.728 is "0 to 418" when Pr.729 = "4303" or more.)
729 N053	Device instance number (Lower 4 digits)	0	0 to 9999 (0 to 4302)	
1426 N641 ^{*1}	Link speed and duplex mode selection	0	0 to 4	Set the communication speed and the communication mode (full-duplex/half-duplex).
1442 N660 ^{*1}	IP filter address 1 (Ethernet)	0	0 to 255	Set the range of connectable IP addresses for the network devices. (When Pr.1442 to Pr.1445 = "0" (initial value)", the function is invalid.)
1443 N661 ^{*1}	IP filter address 2 (Ethernet)	0		
1444 N662 ^{*1}	IP filter address 3 (Ethernet)	0		
1445 N663 ^{*1}	IP filter address 4 (Ethernet)	0		
1446 N664 ^{*1}	IP filter address 2 range specification (Ethernet)	9999	0 to 255, 9999	
1447 N665 ^{*1}	IP filter address 3 range specification (Ethernet)	9999		
1448 N666 ^{*1}	IP filter address 4 range specification (Ethernet)	9999		

*1 The setting is applied after an inverter reset or next power-ON.

◆ Parameters for monitoring (Pr.52, Pr.774 to Pr.776, Pr.992, and Pr.1027 to Pr.1034)

- The following item related to BACnet/IP can be monitored.

Parameter setting for monitor item	Description
83	BACnet valid APDU counter (The count of valid APDU detection is displayed.) ^{*1}

*1 When the count exceeds "9999", the monitor value is reset to "0".

NOTE

- For the description of other settings, refer to the FR-E800 Instruction Manual (Function).

◆ % setting reference frequency (Pr.390)

- Set a reference frequency of the set frequency. The setting value of **Pr.390 % setting reference frequency** is 100% reference. The reference to the frequency command is converted to the set frequency in the following formula.
Set frequency = % setting reference frequency × Speed scale (Refer to [page 114.](#))

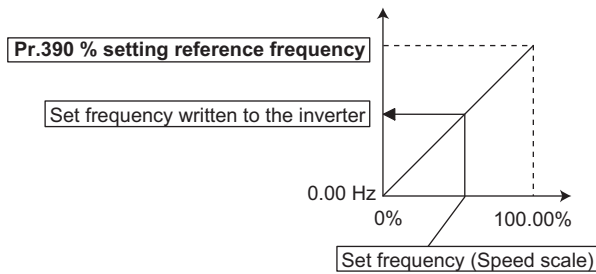

NOTE

- The % setting reference frequency cannot be set at less than the minimum frequency resolution of the inverter.
- The set frequency is written to RAM.
- The set frequency is applied at the writing of Speed scale. (The set frequency is not applied at the setting of **Pr.390.**)

◆ Communication speed and full-duplex/half-duplex selection (Pr.1426)

Use **Pr.1426 Link speed and duplex mode selection** to set the communication speed and the full-duplex or half-duplex system. If the operation is not performed properly in the initial setting (**Pr.1426 = "0"**), set **Pr.1426** according to the specifications of the connected device.

Pr.1426 setting	Communication speed	Full-duplex/half-duplex system	Remarks
0 (initial value)	Automatic negotiation	Automatic negotiation	The communication speed and the communication mode (half-duplex/full-duplex) are automatically negotiated to ensure the optimum setting. To set automatic negotiation, auto negotiation setting is required also in the master station.
1	100 Mbps	Full duplex	—
2	100 Mbps	Half duplex	—
3	10 Mbps	Full duplex	—
4	10 Mbps	Half duplex	—

◆ IP filtering function (Ethernet) (Pr.1442 to Pr.1448)

- Set the IP address range for connectable network devices (**Pr.1442 to Pr.1448**) to limit the connectable devices. The setting range for IP address of connectable network devices depends on the settings in **Pr.1443** and **Pr.1446**, **Pr.1444** and **Pr.1447**, and **Pr.1445** and **Pr.1448**. (Either of the settings can be larger than the other in **Pr.1443** and **Pr.1446**, **Pr.1444** and **Pr.1447**, and **Pr.1445** and **Pr.1448**.)

[Setting example 1]

	Pr.1442	Pr.1443	Pr.1444	Pr.1445	
IP filter address (Ethernet)	192	168	1	100	
	The range is between the values set in both parameters.			The range is between the values set in both parameters.	
	Pr.1446	Pr.1447	Pr.1448		
IP filter address range specification (Ethernet)	—	9999	3	150	

In this case, the IP address range in which Ethernet communication is permitted is "192.168.x (1 to 3).xxx (100 to 150)".

[Setting example 2]

	Pr.1442	Pr.1443	Pr.1444	Pr.1445
IP filter address (Ethernet)	192	168	2	100
	The range is between the values set in both parameters.			
	Pr.1446	Pr.1447	Pr.1448	
IP filter address range specification (Ethernet)	—	9999	9999	50

In this case, the IP address range in which Ethernet communication is permitted is "192.168.2.xxx (50 to 100)".

- When **Pr.1442 to Pr.1445** = "0 (initial value)", the function is invalid.
- When "9999 (initial value)" is set in **Pr.1446 to Pr.1448**, the range is invalid.

⚠ CAUTION

- The IP filtering function (Ethernet) (**Pr.1442 to Pr.1448**) is provided as a means to prevent unauthorized access, DoS attacks, computer viruses, or other cyberattacks from external devices, but the function does not prevent such access completely. In order to protect the inverter and the system against unauthorized access by external systems, take additional security measures. We shall have no responsibility or liability for any problems involving inverter trouble and system trouble by DoS attacks, unauthorized access, computer viruses, and other cyberattacks. The following are examples of measures to prevent them.
 - Install a firewall.
 - Install a personal computer as a relay station, and control the relaying of transmission data using an application program.
 - Install an external device as a relay station to control access rights. (For the details of external devices used to control access rights, contact the distributors of the external devices.)

◆ Supported property of BACnet standard object type

R: Read only, W: Read/Write (Commandable values not supported), C: Read/Write (Commandable values supported)

Property	Object support condition						
	Analog Input	Analog Value	Binary Input	Binary Output	Binary Value	Device	Network Port
APDU Length							R
APDU Timeout						R	
Application Software Version						R	
BACnet IP Mode							R
BACnet IP UDP Port							R
Changes Pending							R
Database Revision						R	
Device Address Binding						R	
Event State	R	R	R	R	R		
Firmware Revision						R	
IP Address							R
IP Default Gateway							R
IP DNS Server							R
IP Subnet Mask							R
Link Speed							R
MAC Address							R
Max APDU Length Accepted						R	
Model Name						R	
Network Number							W
Network Number Quality							R
Network Type							R
Number of APDU Retries						R	
Object Identifier	R	R	R	R	R	R	R
Object List						R	
Object Name	R	R	R	R	R	R	R
Object Type	R	R	R	R	R	R	R
Out Of Service	R	R	R	R	R		R
Polarity			R	R			
Present Value	R	C ^{*1}	R	C	C ^{*1}		
Priority Array		R ^{*2}		R	R ^{*2}		
Protocol Level							R
Protocol Object Types Supported						R	
Protocol Revision						R	
Protocol Services Supported						R	
Protocol Version						R	
Reliability							R
Relinquish Default		R ^{*2}		R	R ^{*2}		

Property	Object support condition						
	Analog Input	Analog Value	Binary Input	Binary Output	Binary Value	Device	Network Port
Segmentation Supported						R	
Status Flags	R	R	R	R	R		R
System Status						R	
Unit	R	R					
Vendor Identifier						R	
Vendor Name						R	
Property List	R	R	R	R	R	R	R
Current Command Priority				R			

*1 This property is commandable for some instances of this object. Otherwise it is read/write.

*2 This property is supported only for instances of this object where the Present Value property is commandable.

◆ Details of the supported properties

- The details of the supported properties are as follows.

Property	Details
APDU Length	Shows the maximum number of octets. Fixed to 1024 octets for the FR-E800.
APDU Timeout	Shows the send retry interval (ms) when there is no reception confirmation response to the APDU request.
Application Software Version	Shows the inverter firmware version.
BACnet IP Mode	Shows the BACnet/IP mode. Fixed to NORMAL (0) for the FR-E800.
BACnet IP UDP Port	Shows the UDP port number of the network port.
Changes Pending	If the property value whose change is to be reflected at a reset is changed, TRUE (1) is returned. FALSE (0) is returned after the status is initialized by a reset.
Database Revision	Always 0.
Device Address Binding	No data.
Event State	Shows the event state of the related object. Fixed to NORMAL (0) for the FR-E800.
Firmware Revision	Shows the firmware level.
IP Address	Shows the octet string of the assigned IP address. For example, C0A83200 is displayed when the IP address is 192.168.50.0.
IP Default Gateway	Shows the octet string of the assigned default gateway address. For example, C0A832FE is displayed when the default gateway address is 192.168.50.254.
IP DNS Server	Always 00000000.
IP Subnet Mask	Shows the octet string of the assigned subnet mask. For example, FFFFFFF0 is displayed when the subnet mask is 255.255.255.0.
Link Speed	Shows the communication speed in the unit of bit/s. It depends on the Pr.1426 setting.
MAC Address	Shows the octet string of the combination of the assigned IP address and UDP port number. For example, C0A83200BAC0 is displayed when the IP address is 192.168.50.0 and the UDP port number is 47808.
Max APDU Length Accepted	Shows the maximum APDU length.
Model Name	Shows the model of the BACnet device.
Network Number	Shows the network number. Fixed to 0 for the FR-E800. If a value other than "0" is written, an error code VALUE_OUT_OF_RANGE (37) will be returned.
Network Number Quality	Shows the quality of the network port number. Fixed to UNKNOWN (0) for the FR-E800.
Network Type	Shows the communication method of the network. Fixed to IPV4 (5) for the FR-E800.
Number of APDU Retries	Shows the maximum number of APDU send retries.
Object Identifier	Shows the unique numeric code to identify the object.
Object List	Shows the object identifier list.
Object Name	Shows the object name.
Object Type	Analog input: ANALOG_INPUT (0) Analog value: ANALOG_VALUE (2) Binary input: BINARY_INPUT (3) Binary output: BINARY_OUTPUT (4) Binary value: BINARY_VALUE (5) Device: DEVICE (8) Network port: NETWORK_PORT (56)

Property	Details
Out Of Service	If the Present Value property is not changed or if the change is not applied, TRUE (1) is returned. FALSE (0) is returned in other cases.
Polarity	REVERSE (1) is returned when the binary output is negative logic. Fixed to NORMAL (0) for the binary input.
Present Value	Shows the present value of each object identifier.
Priority Array	Values to be written to the objects supporting the commandable values are stored. Values are initialized at the power-ON or inverter reset.
Protocol Level	Shows the protocol level. Fixed to BACNET_APPLICATION (2) for the FR-E800.
Protocol Object Types Supported	The bit is 1 for the supported objects or 0 for the other objects.
Protocol Revision	Shows the revision of the compliant BACnet standard.
Protocol Services Supported	The bit is 1 for the supported services or 0 for the other services.
Protocol Version	Shows the version of the compliant BACnet standard.
Reliability	Shows the reliability of the network port. Fixed to no-fault-detected (0) for the FR-E800.
Relinquish Default	Shows the default value to be applied when no data is stored in the Priority Array property.
Segmentation Supported	Shows whether to support segmentation of messages at sending/receiving. Fixed to NO_SEGMENTATION (3) for the FR-E800.
Status Flags	Always 0.
System Status	Shows the current physical and logical status of the device.
Unit	Uses engineering units as the measurement unit.
Vendor Identifier	Shows 16-bit vendor identification code assigned by ASHRAE.
Vendor Name	Mitsubishi Electric Corporation
Property List	Shows the property identifier list.
Current Command Priority	Shows the currently active priority.

◆ Supported BACnet object

- ANALOG INPUT

Object identifier	Object name	Present value access type ^{*1}	Description	Unit
1	Terminal 2	R	Represents actual input voltage (or input current) of terminal 2. (The range varies depending on the Pr.73 and Pr.267 settings. 0 to 10 V (0% to 100%), 0 to 5 V (0% to 100%), 0 to 20 mA (0% to 100%))	percent (98)
2	Terminal 4	R	Represents actual input voltage of terminal 4. (The range varies depending on the Pr.73 and Pr.267 settings. 2 to 10 V (0% to 100%), 1 to 5 V (0% to 100%), 4 to 20 mA (0% to 100%))	percent (98)

*1 R: Read only, W: Read/Write (Commandable values not supported), C: Read/Write (Commandable values supported)

- ANALOG VALUE

Object identifier	Object name	Present value access type ^{*1}	Description	Unit
1	Output frequency ^{*2}	R	Represents the output frequency value.	hertz (27)
2	Output current	R	Represents the output current value.	amperes (3)
3	Output voltage	R	Represents the output voltage value.	volts (5)
6	Running speed ^{*2}	R	Represents the running speed value.	revolution-per-minute (104)
8	Converter output voltage	R	Represents the converter output voltage value.	volts (5)
14	Output power	R	Represents the output power value.	kilowatts (48)
17	Load meter	R	Represents the load meter value.	percent (98)

Object identifier	Object name	Present value access type ^{*1}	Description	Unit
20	Cumulative energization time	R	Represents the cumulative energization time value.	hours (71)
23	Actual operation time	R	Represents the actual operation time value.	hours (71)
25	Cumulative power	R	Represents the cumulative power value.	kilowatt-hours (19)
52	PID set point	R	Represents the PID set point.	no-units (95)
54	PID deviation	R	Represents the PID deviation. (Minus display is available with reference to 0%, in 0.1% increment.)	no-units (95)
67	PID measured value2	R	Represents the PID measurement 2.	no-units (95)
200	Alarm history 1	R	Represents the latest fault record (fault record 1).	no-units (95)
201	Alarm history 2	R	Represents the second latest fault (fault record 2).	no-units (95)
202	Alarm history 3	R	Represents the third latest fault (fault record 3).	no-units (95)
203	Alarm history 4	R	Represents the fourth latest fault (fault record 4).	no-units (95)
300	Speed scale ^{*3}	C	Controls the ratio of the frequency command. (Setting range: 0.00 to 100.00) (Refer to page 111.)	percent (98)
310	PID set point CMD ^{*3}	C	Set the PID action set point. <ul style="list-style-type: none"> This object is the set point during dancer control if Pr.128 = "40 to 43" and Pr.609 = "4". (Setting range: 0.00 to 100.00)^{*5} This object is the set point during PID operation if Pr.128 = "60 or 61". (Setting range: 0.00 to 100.00)^{*4} This object is the set point during PID operation if Pr.128 = "1000 or 1001" and Pr.609 = "4". (Setting range: 0.00 to 100.00)^{*4*5} This object is the set point during PID operation if Pr.128 = "2000 or 2001" (not applied to the frequency) and Pr.609 = "4". (Setting range: 0.00 to 100.00)^{*4*5} 	no-units (95)
311	PID measured value CMD ^{*3}	C	Set the PID measured value. <ul style="list-style-type: none"> This object is the measured value during dancer control if Pr.128 = "40 to 43" and Pr.610 = "4". (Setting range: 0.00 to 100.00) This object is the measured value during PID operation if Pr.128 = "60 or 61". (Setting range: 0.00 to 100.00)^{*4} This object is the measured value during PID operation if Pr.128 = "1000 or 1001" and Pr.610 = "4". (Setting range: 0.00 to 100.00)^{*4} This object is the measured value during PID operation if Pr.128 = "2000 or 2001" (not applied to the frequency) and Pr.610 = "4". (Setting range: 0.00 to 100.00)^{*4} 	no-units (95)
312	PID deviation CMD ^{*3}	C	Set the PID deviation. (0.01 increments) <ul style="list-style-type: none"> This object is the deviation during PID operation if Pr.128 = "50 or 51". (Setting range: -100.00 to 100.00) This object is the deviation during PID operation if Pr.128 = "1010 or 1011" and Pr.609 = "4". (Setting range: -100.00 to 100.00) This object is the deviation during PID operation if Pr.128 = "2010 or 2011" (not applied to the frequency) and Pr.609 = "4". (Setting range: -100.00 to 100.00) 	percent (98)

Object identifier	Object name	Present value access type ^{*1}	Description	Unit
398	Mailbox parameter	W	Access to the properties which are not defined as objects are available. (Refer to page 117.)	no-units (95)
399	Mailbox value	W		no-units (95)
10007	Acceleration time	W	Set Pr.7 Acceleration time.	seconds (73)
10008	Deceleration time	W	Set Pr.8 Deceleration time.	seconds (73)

- *1 R: Read only, W: Read/Write (Commandable values not supported), C: Read/Write (Commandable values supported)
Values written to the objects that support the commandable values are stored in the Priority Array, even when "Write Access Denied" is returned due to inconsistency of the writing requirements such as the operating mode, on condition that the values are written within the setting range.
- *2 The **Pr.37 and Pr.53** settings are invalid.
- *3 If communication speed command source is other than NET, the setting value can be written, but not to be applied.
- *4 When both **C42 and C44** ≠ "9999", the setting range is from the smaller coefficient to the larger coefficient of **C42 and C44**. Depending on the setting, the writing value and the reading value may not be the same at the minimum digit.
- *5 When **Pr.133** ≠ "9999", the **Pr.133** setting is valid.

• BINARY INPUT

Object identifier	Object name	Present value access type ^{*1}	Description (0: inactive, 1: active)
0 ^{*2}	Terminal DI0	R	Represents actual input of terminal DI0.
1 ^{*2}	Terminal DI1	R	Represents actual input of terminal DI1.
100 ^{*2*3}	Terminal RUN	R	Represents actual output of terminal RUN.
104 ^{*2*3}	Terminal FU	R	Represents actual output of terminal FU.
105	Terminal ABC/RO0	R	Represents actual output of terminals A, B, and C.
106 ^{*2*3}	Terminal RO1	R	Represents actual output of terminals A2, B2, and C2.
107 ^{*2*4}	Terminal SO	R	Represents actual output of terminal SO.

- *1 R: Read only, W: Read/Write (Commandable values not supported), C: Read/Write (Commandable values supported)
- *2 For the safety communication model, no function is assigned.
- *3 For the Ethernet model, no function is assigned.
- *4 For the IP67 model, no function is assigned.

• BINARY OUTPUT

Object identifier	Object name	Present value access type ^{*1}	Description (0: inactive, 1: active)
0 ^{*2}	Terminal RUN CMD	C	Controls actual output of terminal RUN. The output can be controlled ^{*3} when the Y82 (BACnet binary output) signal is assigned by setting "82" (positive logic) or "182" (negative logic) in Pr.190 RUN terminal function selection.
4 ^{*2}	Terminal FU CMD	C	Controls actual output of terminal FU. The output can be controlled ^{*3} when the Y82 (BACnet binary output) signal is assigned by setting "82" (positive logic) or "182" (negative logic) in Pr.191 FU terminal function selection.
5	Terminal ABC/RO0 CMD	C	Controls actual output of terminals A, B, and C. The output can be controlled ^{*3} when the Y82 (BACnet binary output) signal is assigned by setting "82" (positive logic) or "182" (negative logic) in Pr.192 ABC terminal function selection.
6 ^{*2}	Terminal RO1 CMD	C	Controls actual output of terminals A2, B2, and C2. The output can be controlled ^{*3} when the Y82 (BACnet binary output) signal is assigned by setting "82" (positive logic) or "182" (negative logic) in Pr.197 ABC2 terminal function selection.

- *1 R: Read only, W: Read/Write (Commandable values not supported), C: Read/Write (Commandable values supported)
Values written to the objects that support the commandable values are stored in the Priority Array, even when "Write Access Denied" is returned due to inconsistency of the writing requirements such as the operating mode, on condition that the values are written within the setting range.
- *2 For the Ethernet model and the safety communication model, no function is assigned.
- *3 Available regardless of the operation mode, operation command source, and speed command source.

• BINARY VALUE

Object identifier	Object name	Present value access type ^{*1}	Description
0	Inverter running	R	Represents inverter running (RUN signal) status.
11	Inverter operation ready	R	Represents inverter operation ready (RY signal) status.
98	Alarm output	R	Represents alarm output (LF signal) status.
99	Fault output	R	Represents fault output (ALM signal) status.
200	Inverter running reverse	R	Represents inverter reverse running status.
300 ^{*2}	Control input instruction DI0	C	Always set to the STF signal regardless of the Pr.178 setting. Setting "1" in this object turns ON the STF signal.
301 ^{*2}	Control input instruction DI1	C	Always set to the STR signal regardless of the Pr.179 setting. Setting "1" in this object turns ON the STR signal.
400	Run/Stop	C	Controls the start/stop command. The start command is written after the Speed scale is applied. ^{*3} 1: Start 0: Stop
401	Forward/Reverse	C	Controls the forward/reverse rotation. ^{*3} 1: Reverse rotation 0: Forward rotation
402	Fault reset	C	Clears fault output status. (Release of an inverter fault without inverter reset is available.)

- *1 R: Read only, W: Read/Write (Commandable values not supported), C: Read/Write (Commandable values supported)
Values written to the objects that support the commandable values are stored in the Priority Array, even when "Write Access Denied" is returned due to inconsistency of the writing requirements such as the operating mode, on condition that the values are written within the setting range.
- *2 For the safety communication model, no function is assigned.
- *3 If communication operation command source is other than NET, the setting value can be written, but not to be applied.

• DEVICE

Object identifier	Object name	Description
0 to 4194302	Model information # device instance number	Reads the device status or changes the setting. Device instance number: Pr.728 × 10000 + Pr.729
4194303 ^{*1}		

*1 Available only for Read Property Service.

• NETWORK PORT

Object identifier	Object name	Description
0	BACnetIP on ISO8802-3(PORT1)	Reads the status of the Ethernet connector (PORT1) or changes the setting.
1	BACnetIP on ISO8802-3(PORT2)	Reads the status of the Ethernet connector (PORT2) or changes the setting.
4194303 ^{*1}	Access is attempted as the object identifier of the port which receives the request.	

*1 Available only for Read Property Service.

◆ Mailbox parameter / Mailbox value (BACnet registers)

- Access to the properties which are not defined as objects are available by using "Mailbox parameter" and "Mailbox value".
- To read a property, write the register of the intended property to "Mailbox parameter", and then read "Mailbox value". To write a property, write the register of the intended property to "Mailbox parameter", and then write a value to "Mailbox value".
- System environment variables

Register	Definition	Read/write	Remarks
40010	Operation mode / inverter setting	Read/write	The data is written as an operation mode setting for writing. The data is read as the operation mode status for reading.

[Operation mode / inverter setting]

Mode	Read value	Write value
EXT	H0000	H0010 ^{*1}
PU	H0001	H0011 ^{*1}

Mode	Read value	Write value
EXT JOG	H0002	—
PU JOG	H0003	—
NET	H0004	H0014
PU + EXT	H0005	—

*1 Writing is available depending on the settings of **Pr.79** and **Pr.340**. For details, refer to the FR-E800 Instruction Manual (Function). Restrictions in each operation mode conform with the computer link specification.

- Monitor code

For details of the register numbers and the monitor items, refer to the description of **Pr.52** in the FR-E800 Instruction Manual (Function).

- Parameter

Pr.	Register	Name	Read/write	Remarks
0 to 999	41000 to 41999	For details on parameter names, refer to the parameter list in the FR-E800 Instruction Manual (Function).	Read/write	The parameter number + 41000 is the register number.
C2 (902)	41902	Terminal 2 frequency setting bias frequency	Read/write	
C3 (902)	42092	Terminal 2 frequency setting bias (analog value)	Read/write	Analog value (%) set in C3 (902)
	43902	Terminal 2 frequency setting bias (terminal analog value)	Read	Analog value (%) of the voltage (current) applied to terminal 2
125 (903)	41903	Terminal 2 frequency setting gain frequency	Read/write	
C4 (903)	42093	Terminal 2 frequency setting gain (analog value)	Read/write	Analog value (%) set in C4 (903)
	43903	Terminal 2 frequency setting gain (terminal analog value)	Read	Analog value (%) of the voltage (current) applied to terminal 2
C5 (904)	41904	Terminal 4 frequency setting bias frequency	Read/write	
C6 (904)	42094	Terminal 4 frequency setting bias (analog value)	Read/write	Analog value (%) set in C6 (904)
	43904	Terminal 4 frequency setting bias (terminal analog value)	Read	Analog value (%) of the current (voltage) applied to terminal 4
126 (905)	41905	Terminal 4 frequency setting gain frequency	Read/write	
C7 (905)	42095	Terminal 4 frequency setting gain (analog value)	Read/write	Analog value (%) set in C7 (905)
	43905	Terminal 4 frequency setting gain (terminal analog value)	Read	Analog value (%) of the current (voltage) applied to terminal 4
C12 (917)	41917	Terminal 1 bias frequency (speed)	Read/write	Available only when the FR-E8AXY is installed.
C13 (917)	42107	Terminal 1 bias (speed) (analog value)	Read/write	Analog value (%) set in C13 (917) (Available only when the FR-E8AXY is installed.)
	43917	Terminal 1 bias (speed) (terminal analog value)	Read	Analog value (%) of the voltage applied to terminal 1 (Available only when the FR-E8AXY is installed.)
C14 (918)	41918	Terminal 1 gain frequency (speed)	Read/write	Available only when the FR-E8AXY is installed.
C15 (918)	42108	Terminal 1 gain (speed) (analog value)	Read/write	Analog value (%) set in C15 (918) (Available only when the FR-E8AXY is installed.)
	43918	Terminal 1 gain (speed) (terminal analog value)	Read	Analog value (%) of the voltage applied to terminal 1 (Available only when the FR-E8AXY is installed.)
C16 (919)	41919	Terminal 1 bias command (torque)	Read/write	Available only when the FR-E8AXY is installed.
C17 (919)	42109	Terminal 1 bias (torque) (analog value)	Read/write	Analog value (%) set in C17 (919) (Available only when the FR-E8AXY is installed.)
	43919	Terminal 1 bias (torque) (terminal analog value)	Read	Analog value (%) of the voltage applied to terminal 1 (Available only when the FR-E8AXY is installed.)
C18 (920)	41920	Terminal 1 gain command (torque)	Read/write	Available only when the FR-E8AXY is installed.
C19 (920)	42110	Terminal 1 gain (torque) (analog value)	Read/write	Analog value (%) set in C19 (920) (Available only when the FR-E8AXY is installed.)
	43920	Terminal 1 gain (torque) (terminal analog value)	Read	Analog value (%) of the voltage applied to terminal 1 (Available only when the FR-E8AXY is installed.)
C38 (932)	41932	Terminal 4 bias command (torque)	Read/write	

Pr.	Register	Name	Read/write	Remarks
C39 (932)	42122	Terminal 4 bias (torque) (analog value)	Read/write	Analog value (%) set in C39 (932)
	43932	Terminal 4 bias (torque) (terminal analog value)	Read	Analog value (%) of the current (voltage) applied to terminal 4
C40 (933)	41933	Terminal 4 gain command (torque)	Read/write	
C41 (933)	42123	Terminal 4 gain (torque) (analog value)	Read/write	Analog value (%) set in C41 (933)
	43933	Terminal 4 gain (torque) (terminal analog value)	Read	Analog value (%) of the current (voltage) applied to terminal 4
C42 (934)	41934	PID display bias coefficient	Read/write	
C43 (934)	42124	PID display bias analog value	Read/write	Analog value (%) set in C43 (934)
	43934	PID display bias analog value (terminal analog value)	Read	Analog value (%) of the current (voltage) applied to terminal 4
C44 (935)	41935	PID display gain coefficient	Read/write	
C45 (935)	42125	PID display gain analog value	Read/write	Analog value (%) set in C45 (935)
	43935	PID display gain analog value (terminal analog value)	Read	Analog value (%) of the current (voltage) applied to terminal 4
1000 to 1999	45000 to 45999	For details on parameter names, refer to the parameter list in the FR-E800 Instruction Manual (Function).	Read/write	The parameter number + 44000 is the register number.

- Fault history

Register	Definition	Read/write	Remarks
40501	Fault record 1	Read/write	Being 2 bytes in length, the data is stored as H00○○. Refer to the lowest 1 byte for the error code. Performing write using the register 40501 batch-clears the fault history. Set any value as data.
40502	Fault record 2	Read	
40503	Fault record 3	Read	
40504	Fault record 4	Read	
40505	Fault record 5	Read	
40506	Fault record 6	Read	
40507	Fault record 7	Read	
40508	Fault record 8	Read	
40509	Fault record 9	Read	
40510	Fault record 10	Read	

- Product profile

Register	Definition	Read/write	Remarks
44001	Model (1st and 2nd characters)	Read	The model name can be read in ASCII code. "H20" (blank code) is set for blank area. Example) FR-E820-EPA: H46, H52, H2D, H45, H38, H32, H30, H2D, H45, H50, H41, H20...H20
44002	Model (3rd and 4th characters)	Read	
44003	Model (5th and 6th characters)	Read	
44004	Model (7th and 8th characters)	Read	
44005	Model (9th and 10th characters)	Read	
44006	Model (11th and 12th characters)	Read	
44007	Model (13th and 14th characters)	Read	
44008	Model (15th and 16th characters)	Read	
44009	Model (17th and 18th characters)	Read	
44010	Model (19th and 20th characters)	Read	
44011	Capacity (1st and 2nd characters)	Read	The inverter rated capacity can be read in ASCII code. Data read is displayed in increments of 0.1 kW (rounded down to one decimal place). "H20" (blank code) is set for blank area. Example) 0.75K: " 7" (H20, H20, H20, H20, H20, H37)
44012	Capacity (3rd and 4th characters)	Read	
44013	Capacity (5th and 6th characters)	Read	

 **NOTE**

- When a 32-bit parameter setting or monitor item is read and the value to be read exceeds HFFFF, HFFFF is returned.

◆ ANNEX A - PROTOCOL IMPLEMENTATION CONFORMANCE STATEMENT (NORMATIVE)

(This annex is part of this Standard and is required for its use.)

BACnet Protocol Implementation Conformance Statement

Date: 9th December 2019

Vendor Name: Mitsubishi Electric Corporation

Product Name: Inverter

Product Model Number: (FR-E800 series)

Application Software Version: 8650*

Firmware Revision: 1.00

BACnet Protocol Revision: 19

Product Description:

BACnet Standardized Device Profile (Annex L):

- BACnet Cross-Domain Advanced Operator Workstation (B-XAWS)
- BACnet Advanced Operator Workstation (B-AWS)
- BACnet Operator Workstation (B-OWS)
- BACnet Operator Display (B-OD)
- BACnet Advanced Life Safety Workstation (B-ALSWS)
- BACnet Life Safety Workstation (B-LSWS)
- BACnet Life Safety Annunciator Panel (B-LSAP)
- BACnet Advanced Access Control Workstation (B-AACWS)
- BACnet Access Control Workstation (B-ACWS)
- BACnet Access Control Security Display (B-ACSD)
- BACnet Building Controller (B-BC)
- BACnet Advanced Application Controller (B-AAC)
- BACnet Application Specific Controller (B-ASC)
- BACnet Smart Sensor (B-SS)
- BACnet Smart Actuator (B-SA)
- BACnet Advanced Life Safety Controller (B-ALSC)
- BACnet Life Safety Controller (B-LSC)
- BACnet Advanced Access Control Controller (B-AACC)
- BACnet Access Control Controller (B-ACC)
- BACnet Router (B-RTR)
- BACnet Gateway (B-GW)
- BACnet Broadcast Management Device (B-BBMD)
- BACnet Access Control Door Controller (B-ACDC)
- BACnet Access Control Credential Reader (B-ACCR)
- BACnet General (B-GENERAL)

List all BACnet Interoperability Building Blocks Supported (Annex K):

DS-RP-B, DS-WP-B, DM-DDB-B, DM-DOB-B, DM-DCC-B, DM-RD-B

Segmentation Capability:

- Able to transmit segmented messages Window Size _____
- Able to receive segmented messages Window Size _____

Standard Object Types Supported:

An object type is supported if it may be present in the device. For each standard Object Type supported provide the following data:

- 1.** Whether objects of this type are dynamically creatable using the CreateObject service
- 2.** Whether objects of this type are dynamically deletable using the DeleteObject service
- 3.** List of the optional properties supported
- 4.** List of all properties that are writable where not otherwise required by this standard
- 5.** List of all properties that are conditionally writable where not otherwise required by this standard
- 6.** List of proprietary properties and for each its property identifier, datatype, and meaning
- 7.** List of any property range restrictions

Dynamic object creation and deletion is not supported.

To check the object types supported by the FR-E800-(SC)EPA and FR-E806-SCEPA, refer to [page 114](#).

Data Link Layer Options:

- ARCNET (ATA 878.1), 2.5 Mb. (Clause 8)
- ARCNET (ATA 878.1), EIA-485 (Clause 8), baud rate(s)
- BACnet IP, (Annex J)
- BACnet IP, (Annex J), BACnet Broadcast Management Device (BBMD)
- BACnet IP, (Annex J), Network Address Translation (NAT Traversal)
- BACnet IPv6, (Annex U)
- BACnet IPv6, (Annex U), BACnet Broadcast Management Device (BBMD)
- BACnet/ZigBee (Annex O)
- ISO 8802-3, Ethernet (Clause 7)
- MS/TP master (Clause 9), baud rate(s):
- MS/TP slave (Clause 9), baud rate(s):
- Point-To-Point, EIA 232 (Clause 10), baud rate(s):
- Point-To-Point, modem, (Clause 10), baud rate(s):
- Other:

Device Address Binding:

Is static device binding supported? (This is currently necessary for two-way communication with MS/TP slaves and certain other devices.) Yes No

Networking Options:

- Router, Clause 6 - List all routing configurations, e.g., ARCNET-Ethernet, Ethernet-MS/TP, etc.
- Annex H, BACnet Tunneling Router over IP

Character Sets Supported:

Indicating support for multiple character sets does not imply that they can all be supported simultaneously.

- ISO 10646 (UTF-8) IBM™/Microsoft™ DBCS ISO 8859-1
- ISO 10646 (UCS-2) ISO 10646 (UCS-4) JIS X 0208

Gateway Options:

If this product is a communication gateway, describe the types of non-BACnet equipment/networks(s) that the gateway supports:

If this product is a communication gateway which presents a network of virtual BACnet devices, a separate PICS shall be provided that describes the functionality of the virtual BACnet devices. That PICS shall describe a superset of the functionality of all types of virtual BACnet devices that can be presented by the gateway.

Network Security Options:

- Non-secure Device - is capable of operating without BACnet Network Security
- Secure Device - is capable of using BACnet Network Security (NS-SD BIBB)
- Multiple Application-Specific Keys
- Supports encryption (NS-ED BIBB)
- Key Server (NS-KS BIBB)

2.9 MELSOFT / FA product connection

2.9.1 Outline

A computer (FR Configurator2), GOT, or a relay station (programmable controller) can be connected via Ethernet.

◆ System configuration

- Direct connection with a computer (FR Configurator2)

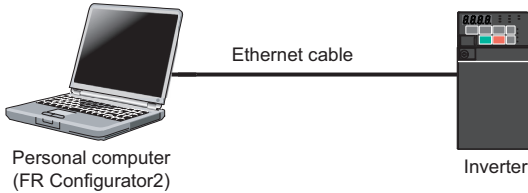

- Direct connection with GOT

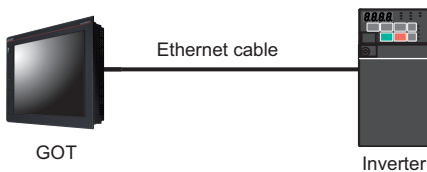

- Connection using a relay station (programmable controller)

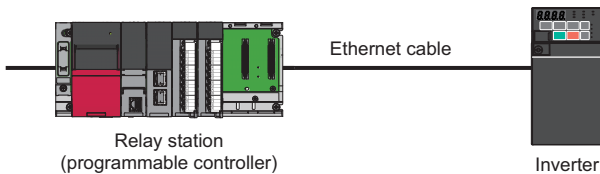

2.9.2 Initial setting for MELSOFT / FA product connection

Use the following parameters to perform required settings for Ethernet communication between the inverter and other devices. To make communication between other devices and the inverter, perform the initial settings of the inverter parameters to match the communication specifications of the devices. Data communication cannot be made if the initial settings are not configured or if there is any setting error.

Pr.	Name	Initial value	Setting range	Description
1427 N630 ^{*1*4}	Ethernet function selection 1	5001	502, 5000 to 5002, 5006 to 5008, 5010 to 5013, 9999, 34962 ^{*3} , 44818 ^{*2} , 45237, 45238, 47808 ^{*2} , 61450	Set the application, protocol, etc.
1428 N631 ^{*1*4}	Ethernet function selection 2	45237		
1429 N632 ^{*1*4}	Ethernet function selection 3	45238		
1430 N633 ^{*1*4}	Ethernet function selection 4	9999		
1424 N650 ^{*1*4}	Ethernet communication network number	1	1 to 239	Enter the network number.
1425 N651 ^{*1*4}	Ethernet communication station number	1	1 to 120	Enter the station number.

*1 The setting is applied after an inverter reset or next power-ON.

*2 The setting is available for the FR-E800-(SC)EPA and FR-E806-SCEPA.

*3 The setting is available for the FR-E800-(SC)EPB and FR-E806-SCEPB.

*4 The setting is not available for the FR-E800-(SC)EPC.

NOTE

- Enable the PLC function (**Pr.414 PLC function operation selection** ≠ "0 (initial value)") to use FR Configurator2 (Developer). (For details of **Pr.414**, refer to the FR-E800 Instruction Manual (Function).)
When the FR-E800-(SC)EPC is used, connect the devices with a USB cable. (Refer to [page 278](#).)

◆ **Ethernet function selection (Pr.1427 to Pr.1430)**

To select MELSOFT / FA product connection for the application, set any value from "5000 to 5002" or "5006 to 5008" (MELSOFT / FA product connection) in any of **Pr.1427 to Pr.1430 Ethernet function selection 1 to 4**. (For how to set the application value, refer to the Instruction Manual of the device connected via Ethernet.) (Refer to [page 226](#).)

◆ **Ethernet communication network number (Pr.1424), Ethernet communication station number (Pr.1425)**

- When the MELSOFT / FA product connection, SLMP, or iQSS is selected for Ethernet communication, enter the Ethernet communication network number in **Pr.1424** and the Ethernet communication station number in **Pr.1425**.

2.9.3 Parameters related to MELSOFT / FA product connection

The following parameters are used for communication via MELSOFT / FA product. Set the parameters as required.

Pr.	Name	Initial value	Setting range	Description
1426 N641 ^{*1}	Link speed and duplex mode selection	0	0 to 4	Set the communication speed and the communication mode (full-duplex/half-duplex).
1442 N660 ^{*1}	IP filter address 1 (Ethernet)	0	0 to 255	Set the range of connectable IP addresses for the network devices. (When Pr.1442 to Pr.1445 = "0 (initial value)", the function is invalid.)
1443 N661 ^{*1}	IP filter address 2 (Ethernet)	0		
1444 N662 ^{*1}	IP filter address 3 (Ethernet)	0		
1445 N663 ^{*1}	IP filter address 4 (Ethernet)	0		
1446 N664 ^{*1}	IP filter address 2 range specification (Ethernet)	9999		
1447 N665 ^{*1}	IP filter address 3 range specification (Ethernet)	9999		
1448 N666 ^{*1}	IP filter address 4 range specification (Ethernet)	9999		

*1 The setting is applied after an inverter reset or next power-ON.

◆ **Communication speed and full-duplex/half-duplex selection (Pr.1426)**

Use **Pr.1426 Link speed and duplex mode selection** to set the communication speed and the full-duplex or half-duplex system. If the operation is not performed properly in the initial setting (**Pr.1426** = "0"), set **Pr.1426** according to the specifications of the connected device.

Pr.1426 setting	Communication speed	Full-duplex/half-duplex system	Remarks
0 (initial value)	Automatic negotiation	Automatic negotiation	The communication speed and the communication mode (half-duplex/full-duplex) are automatically negotiated to ensure the optimum setting. To set automatic negotiation, auto negotiation setting is required also in the master station.
1	100 Mbps	Full duplex	—
2	100 Mbps	Half duplex	—
3	10 Mbps	Full duplex	—
4	10 Mbps	Half duplex	—

◆ IP filtering function (Ethernet) (Pr.1442 to Pr.1448)

- Set the IP address range for connectable network devices (**Pr.1442 to Pr.1448**) to limit the connectable devices. The setting range for IP address of connectable network devices depends on the settings in **Pr.1443** and **Pr.1446**, **Pr.1444** and **Pr.1447**, and **Pr.1445** and **Pr.1448**. (Either of the settings can be larger than the other in **Pr.1443** and **Pr.1446**, **Pr.1444** and **Pr.1447**, and **Pr.1445** and **Pr.1448**.)

[Setting example 1]

	Pr.1442	Pr.1443	Pr.1444	Pr.1445	
IP filter address (Ethernet)	192	168	1	100	
	The range is between the values set in both parameters.			The range is between the values set in both parameters.	
		Pr.1446	Pr.1447	Pr.1448	
IP filter address range specification (Ethernet)	—	9999	3	150	

In this case, the IP address range in which Ethernet communication is permitted is "192.168.x (1 to 3).xxx (100 to 150)".

[Setting example 2]

	Pr.1442	Pr.1443	Pr.1444	Pr.1445
IP filter address (Ethernet)	192	168	2	100
	The range is between the values set in both parameters.			
		Pr.1446	Pr.1447	Pr.1448
IP filter address range specification (Ethernet)	—	9999	9999	50

In this case, the IP address range in which Ethernet communication is permitted is "192.168.2.xxx (50 to 100)".

- When **Pr.1442 to Pr.1445** = "0 (initial value)", the function is invalid.
- When "9999 (initial value)" is set in **Pr.1446 to Pr.1448**, the range is invalid.

⚠ CAUTION

- The IP filtering function (Ethernet) (**Pr.1442 to Pr.1448**) is provided as a means to prevent unauthorized access, DoS attacks, computer viruses, or other cyberattacks from external devices, but the function does not prevent such access completely. In order to protect the inverter and the system against unauthorized access by external systems, take additional security measures. We shall have no responsibility or liability for any problems involving inverter trouble and system trouble by DoS attacks, unauthorized access, computer viruses, and other cyberattacks. The following are examples of measures to prevent them.
 - Install a firewall.
 - Install a personal computer as a relay station, and control the relaying of transmission data using an application program.
 - Install an external device as a relay station to control access rights. (For the details of external devices used to control access rights, contact the distributors of the external devices.)

2.10 SLMP

2.10.1 Outline

SLMP is a common protocol for seamless communication between applications. Users do not have to be concerned with network layers or boundaries. SLMP communications are available among devices that can transfer messages by SLMP (programmable controllers, personal computers, HMI's and others). (For the details of the SLMP compatibility of external devices, refer to the Instruction Manual of external devices.)

Some functions are not supported depending on the date of manufacture of the inverter. For details of specification changes, refer to [page 290](#).

2.10.2 Initial setting for SLMP

Use the following parameters to perform required settings for Ethernet communication between the inverter and other devices. To make communication between other devices and the inverter, perform the initial settings of the inverter parameters to match the communication specifications of the devices. Data communication cannot be made if the initial settings are not configured or if there is any setting error.

SLMP can be used only when the PLC function is enabled. Set **Pr.414 PLC function operation selection** ≠ "0 (initial value)". (For details of **Pr.414**, refer to the FR-E800 Instruction Manual (Function).)

Pr.	Name	Initial value	Setting range	Setting range
1427 N630 ^{*1}	Ethernet function selection 1	5001	502, 5000 to 5002, 5006 to 5008, 5010 to 5013, 9999, 34962 ^{*3} , 44818 ^{*2} , 45237, 45238, 47808 ^{*2} , 61450	Set the application, protocol, etc.
1428 N631 ^{*1}	Ethernet function selection 2	45237		
1429 N632 ^{*1}	Ethernet function selection 3	45238		
1430 N633 ^{*1}	Ethernet function selection 4	9999		
1424 N650 ^{*1}	Ethernet communication network number	1	1 to 239	Enter the network number.
1425 N651 ^{*1}	Ethernet communication station number	1	1 to 120	Enter the station number.

*1 The setting is applied after an inverter reset or next power-ON.

*2 The setting is available for the FR-E800-(SC)EPA and FR-E806-SCEPA.

*3 The setting is available for the FR-E800-(SC)EPB and FR-E806-SCEPB.

NOTE

- The Ethernet model, the safety communication model, and the IP67 model only supports binary code. (ASCII code is not supported.)

◆ Ethernet function selection (Pr.1427 to Pr.1430)

To select SLMP for the application, set any value from "5010 to 5013" (SLMP) in any of **Pr.1427 to Pr.1430 Ethernet function selection 1 to 4**. (Refer to [page 226](#).)

◆ Ethernet communication network number (Pr.1424), Ethernet communication station number (Pr.1425)

- When the MELSOFT / FA product connection, SLMP, or iQSS is selected for Ethernet communication, enter the Ethernet communication network number in **Pr.1424** and the Ethernet communication station number in **Pr.1425**.

2.10.3 Parameters related to SLMP

The following parameters are used for SLMP communication. Set the parameters as required.

Pr.	Name	Initial value	Setting range	Setting range
1426 N641 ^{*1}	Link speed and duplex mode selection	0	0 to 4	Set the communication speed and the communication mode (full-duplex/half-duplex).
1442 N660 ^{*1}	IP filter address 1 (Ethernet)	0	0 to 255	Set the range of connectable IP addresses for the network devices. (When Pr.1442 to Pr.1445 = "0 (initial value)", the function is invalid.)
1443 N661 ^{*1}	IP filter address 2 (Ethernet)	0		
1444 N662 ^{*1}	IP filter address 3 (Ethernet)	0		
1445 N663 ^{*1}	IP filter address 4 (Ethernet)	0		
1446 N664 ^{*1}	IP filter address 2 range specification (Ethernet)	9999	0 to 255, 9999	
1447 N665 ^{*1}	IP filter address 3 range specification (Ethernet)	9999		
1448 N666 ^{*1}	IP filter address 4 range specification (Ethernet)	9999		

*1 The setting is applied after an inverter reset or next power-ON.

◆ Communication speed and full-duplex/half-duplex selection (Pr.1426)

Use **Pr.1426 Link speed and duplex mode selection** to set the communication speed and the full-duplex or half-duplex system. If the operation is not performed properly in the initial setting (**Pr.1426** = "0"), set **Pr.1426** according to the specifications of the connected device.

Pr.1426 setting	Communication speed	Full-duplex/half-duplex system	Remarks
0 (initial value)	Automatic negotiation	Automatic negotiation	The communication speed and the communication mode (half-duplex/full-duplex) are automatically negotiated to ensure the optimum setting. To set automatic negotiation, auto negotiation setting is required also in the master station.
1	100 Mbps	Full duplex	—
2	100 Mbps	Half duplex	—
3	10 Mbps	Full duplex	—
4	10 Mbps	Half duplex	—

◆ IP filtering function (Ethernet) (Pr.1442 to Pr.1448)

- Set the IP address range for connectable network devices (**Pr.1442 to Pr.1448**) to limit the connectable devices. The setting range for IP address of connectable network devices depends on the settings in **Pr.1443** and **Pr.1446**, **Pr.1444** and **Pr.1447**, and **Pr.1445** and **Pr.1448**. (Either of the settings can be larger than the other in **Pr.1443** and **Pr.1446**, **Pr.1444** and **Pr.1447**, and **Pr.1445** and **Pr.1448**.)

[Setting example 1]

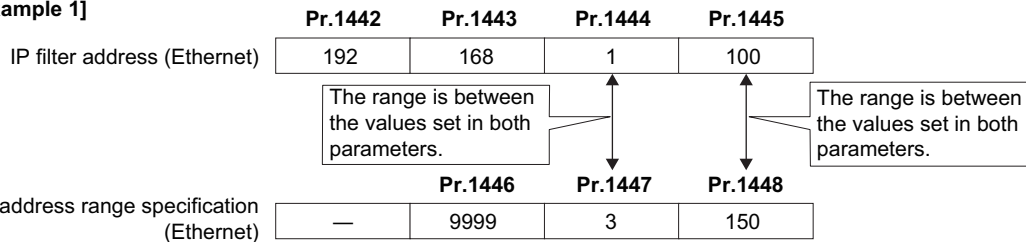

In this case, the IP address range in which Ethernet communication is permitted is "192.168.x (1 to 3).xxx (100 to 150)".

[Setting example 2]

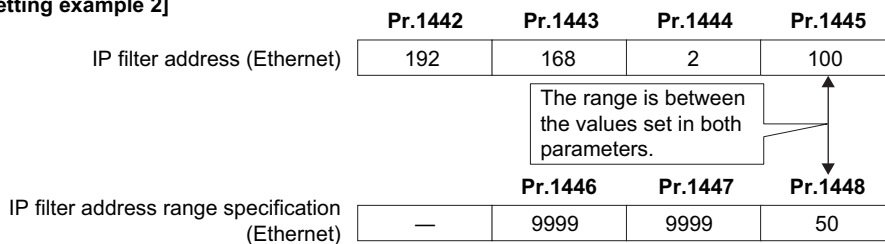

In this case, the IP address range in which Ethernet communication is permitted is "192.168.2.xxx (50 to 100)".

- When **Pr.1442 to Pr.1445** = "0 (initial value)", the function is invalid.
- When "9999 (initial value)" is set in **Pr.1446 to Pr.1448**, the range is invalid.

⚠ CAUTION

- The IP filtering function (Ethernet) (**Pr.1442 to Pr.1448**) is provided as a means to prevent unauthorized access, DoS attacks, computer viruses, or other cyberattacks from external devices, but the function does not prevent such access completely. In order to protect the inverter and the system against unauthorized access by external systems, take additional security measures. We shall have no responsibility or liability for any problems involving inverter trouble and system trouble by DoS attacks, unauthorized access, computer viruses, and other cyberattacks. The following are examples of measures to prevent them.
 - Install a firewall.
 - Install a personal computer as a relay station, and control the relaying of transmission data using an application program.
 - Install an external device as a relay station to control access rights. (For the details of external devices used to control access rights, contact the distributors of the external devices.)

◆ Communication procedure

- Using TCP/IP

The following is the communication procedure when executing SLMP communication with TCP/IP.

With TCP/IP, connections are established when communication is executed, and whether data is received normally or not is checked to ensure reliability of data. However, the line load is higher as compared to UDP.

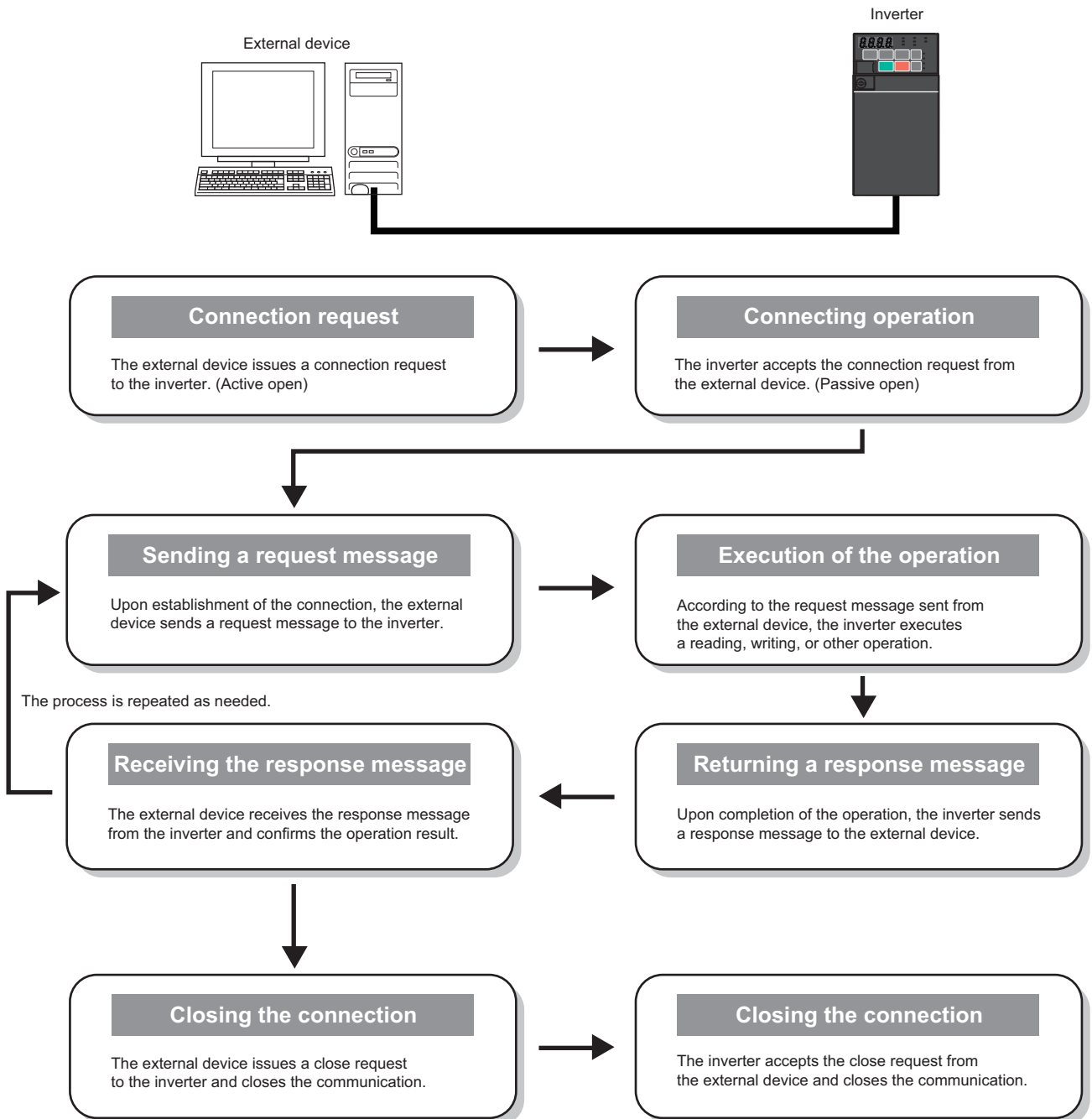

- Using UDP

The following is the communication procedure when executing SLMP communication with UDP.

With UDP, connections are not established when communication is executed, and whether data is received normally or not is not checked. Therefore, the line load is low. However, data is less reliable as compared to TCP/IP.

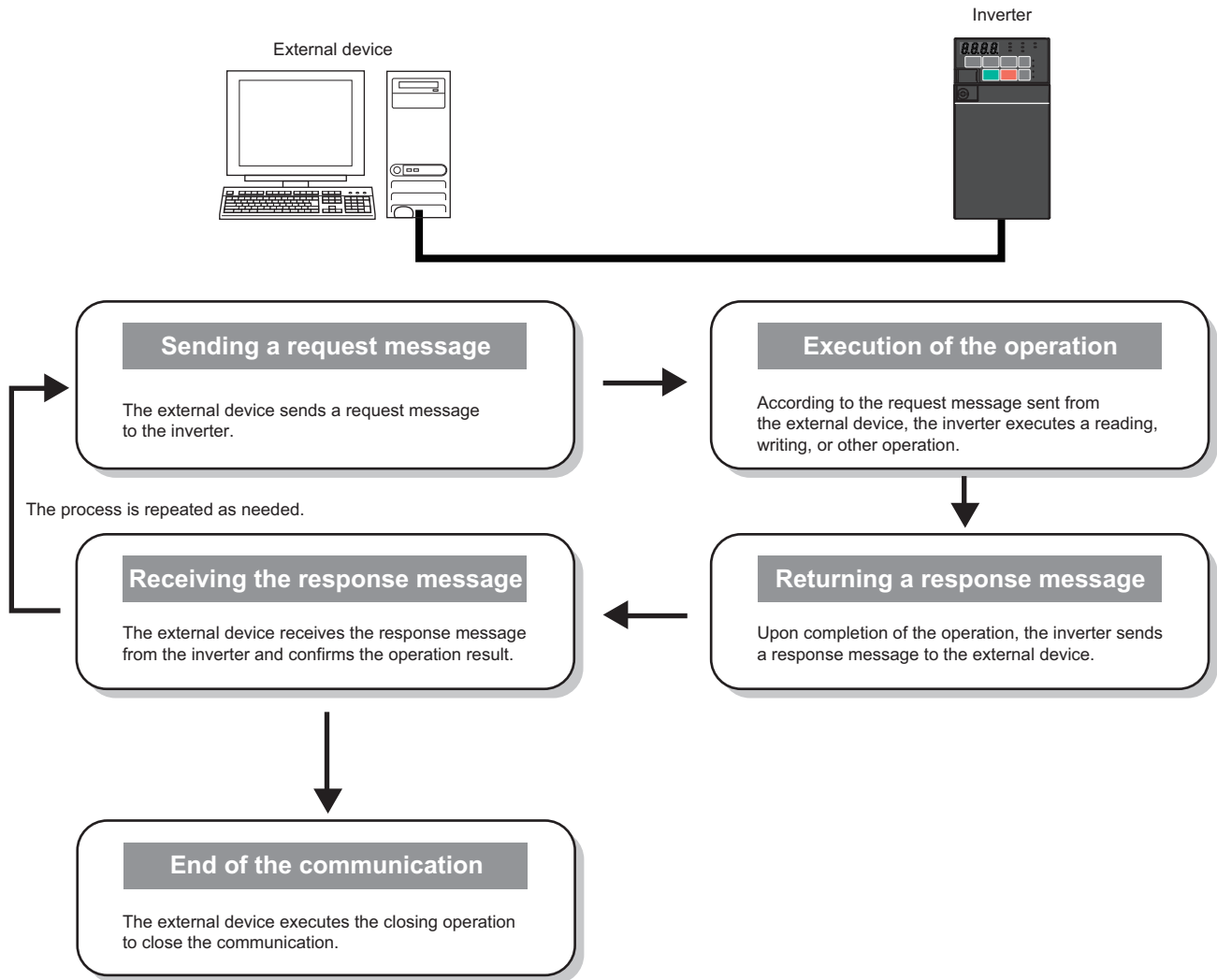

◆ Message format

- Request message format

The following is the format of a request message sent from the external device to the inverter. The request message data length is 2047 bytes at the maximum.

Header	Subheader	Destination network No.	Destination station No.	Destination unit I/O No.	Destination multidrop station No.	Request data length	Monitoring timer	Request data	Footer

• Response message format

The following is the format of a response message sent from the inverter to the external device. The response message data length is 2048 bytes at the maximum.

• Normal completion

Header	Subheader	Destination network No.	Destination station No.	Destination unit I/O No.	Destination multidrop station No.	Response data length	End code	Response data	Footer
--------	-----------	-------------------------	-------------------------	--------------------------	-----------------------------------	----------------------	----------	---------------	--------

• Failed completion

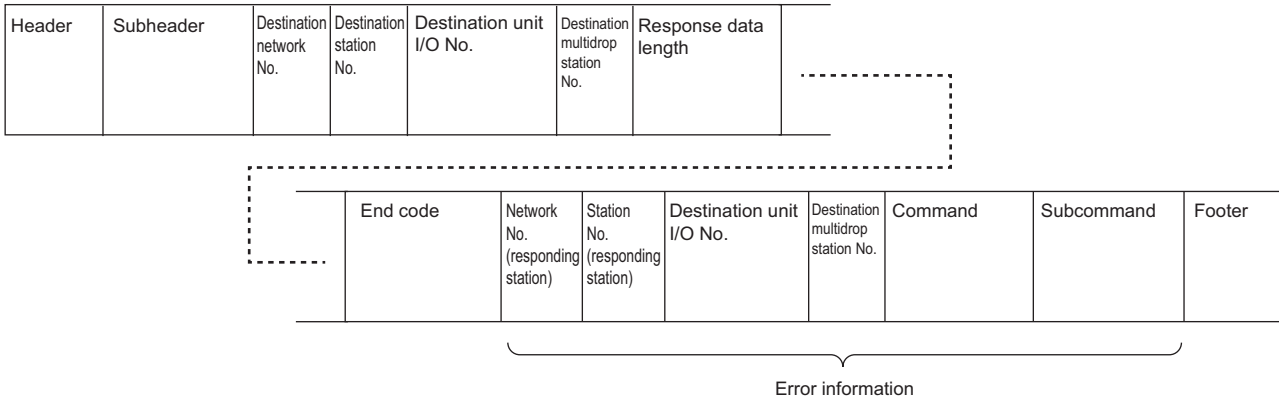

Item	Size	Endian	Description	
Header	—	—	Header for TCP/IP or UDP. The header is added by the external device before transmission.	
Subheader (QnA-compatible 3E frame)	2 bytes	Big	Request: H5000 Response: HD000	
Subheader (QnA-compatible 4E frame)	6 bytes		Request: H5400 + Serial No. *1 + H0000 Response: HD400 + Serial No. *1 + H0000	
Destination network No.	1 byte	—	Specify the network No. of the access destination. Use a hexadecimal value to specify the network number. Own station: H00 Other stations: H01 to HEF (1 to 239)	The own station has a network No. of H00 and a station No. of HFF. The other stations have other values. The request data addressed to the own station is received regardless of the network No. and station No. settings. The request data addressed to the other stations is received when the Pr.1424 and Pr.1425 settings are the same.
Destination station No.	1 byte	—	Specify the station No. of the access destination. Use a hexadecimal value to specify the station number. Own station: HFF (when the network No. is H00) Other stations: H01 to H78 (1 to 120)	
Destination unit I/O No.	2 bytes	Little	Fixed to H03FF	
Destination multidrop station No.	1 byte	—	Fixed to H00	
Request data length	2 bytes	Little	Specify the data length from the monitoring timer to the request data in hexadecimal. Example) 24 bytes: H1800	
Monitoring timer	2 bytes	Little	Set the waiting time until the inverter completes reading/writing after receiving a request message from the external device. When the inverter does not return the response message within the waiting time, the response message will be discarded. <ul style="list-style-type: none"> • H0000: Unlimited (until the execution is completed) • H0001 to HFFFF (1 to 65535): Waiting time (Unit: 0.25 s) Recommended setting <ul style="list-style-type: none"> • When the access destination is the own station: Monitoring, operation command, frequency setting (RAM): H1 to H40 (0.25 to 10 s) Parameter read/write, frequency setting (EEPROM): H1 to H40 (0.25 to 10 s) Parameter clear / All parameter clear: H15 to H40 (5.25 to 10 s) • When the access destination is any other station: Monitoring, operation command, frequency setting (RAM): H2 to H40 (0.5 to 60 s) Parameter read/write, frequency setting (EEPROM): H2 to H40 (0.5 to 60 s) Parameter clear / All parameter clear: H15 to H40 (5.25 to 60 s) 	
Request data	Variable	Little	Specify the command, subcommand, and data that indicate the requested operation. (Refer to page 132.)	

Item	Size	Endian	Description
Response data length	2 bytes	Little	The data length from the end code to the response data (when completed) or error information (when failed) is stored in hexadecimal. (Unit: byte)
End code	2 bytes	Little	The command processing result is stored. The value "0" is stored for normal completion. The error code of the access destination (refer to page 142) is stored for failed completion.
Response data	Variable	Little	When the command is completed normally, data such as the read data corresponding to the command is stored.
Error information	9 bytes	—	The network No. (responding station) (1 byte), station No. (responding station) (1 byte), destination unit I/O No. (2 bytes), and destination multidrop station No. (1 byte) of the stations which respond errors are stored for failed completion. Numbers different from those in the request message may be stored because the information on the station with error response is stored. The command (2 bytes) and the subcommand (2 bytes) being issued when an error occurred are also stored.
Footer	—	—	Footer for TCP/IP or UDP. The footer is added by the external device before transmission.

*1 The serial No. is given by the external device for message recognition. If a request message with a serial No. is sent, the same serial No. will also be added on the response message. The serial No. is used when multiple request messages are sent from an external device to the same inverter.

◆ Command

- The following table lists the commands and subcommands. (When the inverter receives a command other than listed in the following table, it returns an error code (HC059).)

Category	Operation	Command	Subcommand	Description	Refer to page	
Device	Read	In bit units	H0401	H0001	The inverter reads the value in bit devices (with consecutive device numbers) in 1-bit units.	139
		In word units	H0401	H0000	The inverter reads the value in bit devices (with consecutive device numbers) in 16-bit units. The inverter reads the value in word devices (with consecutive device numbers) in 1-word units.	
	Write	In bit units	H1401	H0001	The inverter writes the value to bit devices (with consecutive device numbers) in 1-bit units.	
		In word units	H1401	H0000	The inverter writes the value to bit devices (with consecutive device numbers) in 16-bit units. The inverter writes the value to word devices (with consecutive device numbers) in 1-word units.	
	Read Random	In word units	H0403	H0000	The inverter reads the value in the devices with the specified numbers. The devices with non-consecutive numbers can be specified. The value is read from the word devices in 1-word or 2-word units.	139
	Write Random	In bit units	H1402	H0001	The inverter writes the value to the bit devices with the specified device numbers (each bit has a device number). The devices with non-consecutive numbers can be specified.	140
		In word units	H1402	H0000	The inverter writes the value to the bit devices with the specified device numbers (each set of 16 bits has a device number). The devices with non-consecutive numbers can be specified.	
	The inverter writes the value to the word devices with the specified device numbers (each word or each set of two words has a device number). The devices with non-consecutive numbers can be specified.					
Remote Control	Remote Run		H1001	H0000	Remote Run is performed to the inverter.	141
	Remote Stop		H1002	H0000	Remote Stop is performed to the inverter.	141
	Read Type name		H0101	H0000	The model name and model code of the inverter are read.	141

◆ Device

- The following table lists the device codes and the range available for each command.

Device	Category	Device code	Range ^{*1}
Special relay (SM)	Bit	H91	Refer to the PLC Function Programming Manual. ^{*2}
Special register (SD)	Word	HA9	
Input (X)	Bit	H9C	H0 to H7F (hexadecimal)
Output (Y)	Bit	H9D	H0 to H7F (hexadecimal)
Internal relay (M)	Bit	H90	0 to 127 (decimal)

Device		Category	Device code	Range ^{*1}
Data register (D)		Word	HA8	0 to 255 (decimal)
Link register (W)		Word	HB4	8192
Timer (T)	Contact (TS)	Bit	HC1	0 to 15 (decimal)
	Coil (TC)		HC0	
	Current value (TN)	Word	HC2	
Retentive timer (S)	Contact (SS)	Bit	HC7	0 (Initial value. Up to 16 retentive timers can be used by PLC parameter assignment.)
	Coil (SC)		HC6	
	Current value (SN)	Word	HC8	
Counter (C)	Contact (CS)	Bit	HC4	0 to 15 (decimal)
	Coil (CC)		HC3	
	Current value (CN)	Word	HC5	

*1 If write/read is requested from/to any devices outside the range, the error code H4031 is returned. (Refer to [page 142](#).)

*2 When setting the word unit of the special relay device, specify the device No. in the list of special relay as the first device No. For details of the special relay, refer to the PLC function programming manual. Otherwise, the data is not read/written correctly.

◆ Link register

The following shows the link registers for parameters (read/write), inverter status monitor items (read), fault history (read), preventive maintenance data (read), model information monitor items (read), and serial numbers (read).

- Parameter

Pr.	Register	Name	Read/write	Remarks
0 to 999	W0 to W999	For details on parameter names, refer to the parameter list in the FR-E800 Instruction Manual (Function).	Read/write	
C2 (902)	W902	Terminal 2 frequency setting bias frequency	Read/write	
C3 (902)	W4802	Terminal 2 frequency setting bias (analog value)	Read/write	Analog value (%) set in C3 (902)
	W4902	Terminal 2 frequency setting bias (terminal analog value)	Read	Analog value (%) of the voltage (current) applied to terminal 2
125 (903)	W903	Terminal 2 frequency setting gain frequency	Read/write	
C4 (903)	W4803	Terminal 2 frequency setting gain (analog value)	Read/write	Analog value (%) set in C4 (903)
	W4903	Terminal 2 frequency setting gain (terminal analog value)	Read	Analog value (%) of the voltage (current) applied to terminal 2
C5 (904)	W904	Terminal 4 frequency setting bias frequency	Read/write	
C6 (904)	W4804	Terminal 4 frequency setting bias (analog value)	Read/write	Analog value (%) set in C6 (904)
	W4904	Terminal 4 frequency setting bias (terminal analog value)	Read	Analog value (%) of the current (voltage) applied to terminal 4
126 (905)	W905	Terminal 4 frequency setting gain frequency	Read/write	
C7 (905)	W4805	Terminal 4 frequency setting gain (analog value)	Read/write	Analog value (%) set in C7 (905)
	W4905	Terminal 4 frequency setting gain (terminal analog value)	Read	Analog value (%) of the current (voltage) applied to terminal 4
C12 (917)	W917	Terminal 1 bias frequency (speed)	Read/write	Available only when the FR-E8AXY is installed.
C13 (917)	W4817	Terminal 1 bias (speed) (analog value)	Read/write	Analog value (%) set in C13 (917) (Available only when the FR-E8AXY is installed.)
	W4917	Terminal 1 bias (speed) (terminal analog value)	Read	Analog value (%) of the voltage applied to terminal 1 (Available only when the FR-E8AXY is installed.)
C14 (918)	W918	Terminal 1 gain frequency (speed)	Read/write	Available only when the FR-E8AXY is installed.
C15 (918)	W4818	Terminal 1 gain (speed) (analog value)	Read/write	Analog value (%) set in C15 (918) (Available only when the FR-E8AXY is installed.)
	W4918	Terminal 1 gain (speed) (terminal analog value)	Read	Analog value (%) of the voltage applied to terminal 1 (Available only when the FR-E8AXY is installed.)
C16 (919)	W919	Terminal 1 bias command (torque)	Read/write	Available only when the FR-E8AXY is installed.

Pr.	Register	Name	Read/write	Remarks
C17 (919)	W4819	Terminal 1 bias (torque) (analog value)	Read/write	Analog value (%) set in C17 (919) (Available only when the FR-E8AXY is installed.)
	W4919	Terminal 1 bias (torque) (terminal analog value)	Read	Analog value (%) of the voltage applied to terminal 1 (Available only when the FR-E8AXY is installed.)
C18 (920)	W920	Terminal 1 gain command (torque)	Read/write	Available only when the FR-E8AXY is installed.
C19 (920)	W4820	Terminal 1 gain (torque) (analog value)	Read/write	Analog value (%) set in C19 (920) (Available only when the FR-E8AXY is installed.)
	W4920	Terminal 1 gain (torque) (terminal analog value)	Read	Analog value (%) of the voltage applied to terminal 1 (Available only when the FR-E8AXY is installed.)
C38 (932)	W932	Terminal 4 bias command (torque)	Read/write	
C39 (932)	W4832	Terminal 4 bias (torque) (analog value)	Read/write	Analog value (%) set in C39 (932)
	W4932	Terminal 4 bias (torque) (terminal analog value)	Read	Analog value (%) of the current (voltage) applied to terminal 4
C40 (933)	W933	Terminal 4 gain command (torque)	Read/write	
C41 (933)	W4833	Terminal 4 gain (torque) (analog value)	Read/write	Analog value (%) set in C41 (933)
	W4933	Terminal 4 gain (torque) (terminal analog value)	Read	Analog value (%) of the current (voltage) applied to terminal 4
C42 (934)	W934	PID display bias coefficient	Read/write	
C43 (934)	W4834	PID display bias analog value	Read/write	Analog value (%) set in C43 (934)
	W4934	PID display bias analog value (terminal analog value)	Read	Analog value (%) of the current (voltage) applied to terminal 4
C44 (935)	W935	PID display gain coefficient	Read/write	
C45 (935)	W4835	PID display gain analog value	Read/write	Analog value (%) set in C45 (935)
	W4935	PID display gain analog value (terminal analog value)	Read	Analog value (%) of the current (voltage) applied to terminal 4
1000 to 1499	W1000 to W1499	For details on parameter names, refer to the parameter list in the FR-E800 Instruction Manual (Function).	Read/write	

- Inverter status

Register	Monitor item	Read/write
W5001	Output frequency/speed	Read
W5002	Output current	Read
W5003	Output voltage	Read
W5005	Set frequency / motor speed setting	Read
W5006	Operation speed	Read
W5007	Motor torque	Read
W5008	Converter output voltage	Read
W5009	Regenerative brake duty	Read
W5010	Electronic thermal O/L relay load factor	Read
W5011	Output current peak value	Read
W5012	Converter output voltage peak value	Read
W5013	Input power	Read
W5014	Output power	Read
W5015	Input terminal status	Read
W5016	Output terminal status	Read
W5017	Load meter	Read
W5018	Motor excitation current	Read
W5019	Position pulse	Read
W5020	Cumulative energization time	Read
W5022	Orientation status	Read
W5023	Actual operation time	Read
W5024	Motor load factor	Read
W5025	Cumulative power	Read
W5026	Position command (lower)	Read
W5027	Position command (upper)	Read
W5028	Current position (lower)	Read
W5029	Current position (upper)	Read
W5030	Droop pulse (lower)	Read
W5031	Droop pulse (upper)	Read
W5032	Torque command	Read
W5033	Torque current command	Read

Register	Monitor item	Read/write
W5035	Feedback pulse	Read
W5038	Trace status	Read
W5040	PLC function user monitor 1	Read
W5041	PLC function user monitor 2	Read
W5042	PLC function user monitor 3	Read
W5045	Station number (CC-Link)	Read
W5050	Energy saving effect	Read
W5051	Cumulative energy saving	Read
W5052	PID set point	Read
W5053	PID measured value	Read
W5054	PID deviation	Read
W5058	Option input terminal status 1 (for communication)	Read
W5059	Option input terminal status 2 (for communication)	Read
W5060	Option output terminal status (for communication)	Read
W5061	Motor thermal load factor	Read
W5062	Inverter thermal load factor	Read
W5064	PTC thermistor resistance	Read
W5065	Ideal speed command	Read
W5067	PID measured value 2	Read
W5068	Emergency drive status	Read
W5071	Cumulative pulse	Read
W5072	Cumulative pulse overflow times	Read
W5077	32-bit cumulative energy (lower 16 bits)	Read
W5078	32-bit cumulative energy (upper 16 bits)	Read
W5079	32-bit cumulative energy (lower 16 bits)	Read
W5080	32-bit cumulative energy (upper 16 bits)	Read
W5083	BACnet valid APDU counter	Read
W5091	PID manipulated amount	Read
W5097	Dancer main speed setting	Read
W5807	Inverter status 1	Read
W5808	Inverter status 2	Read

- Inverter status 1, inverter status 2

Bit	Definition	
	Inverter status 1	Inverter status 2
0	Inverter running	DO0 (0) ^{*2}
1	During forward rotation	DO1 (0) ^{*2}
2	During reverse rotation	DO2 (0) ^{*2}
3	Up to frequency	DO3 (0) ^{*2}
4	Overload warning	DO4 (0) ^{*2}
5	0	DO5 (0) ^{*2}
6	Output frequency detection	DO6 (0) ^{*2}
7	Fault	RA1 (Inverter running) ^{*2}
8	Alarm	RA2 (Up to frequency) ^{*2}
9	NET Y1 (0) ^{*1}	RA3 (Output frequency detection) ^{*2}
10	NET Y2 (0) ^{*1}	0
11	NET Y3 (0) ^{*1}	0
12	NET Y4 (0) ^{*1}	0
13	0	0
14	0	0
15	SO	0

- *1 The signal within parentheses () is assigned in the initial status. The function changes depending on the setting of **Pr.193 to Pr.196 (Output terminal function selection)**.
For details, refer to the description of **Pr.193 to Pr.196 (Output terminal function selection)** in the FR-E800 Instruction Manual (Function).
- *2 The signal within parentheses () is assigned in the initial status. The function changes depending on the setting of **Pr.313 to Pr.322 (Output terminal function selection)**.
For details, refer to the description of **Pr.313 to Pr.322 (Output terminal function selection)** in the FR-E800 Instruction Manual (Function).

- Fault history

Register	Definition	Read/write	Remarks
W5900 to W5906	Fault record 1	Read	Example) For fault record 1 W5900: Error code W5901: Output frequency at error occurrence W5902: Output current at error occurrence W5903: Output voltage at error occurrence W5904: Energization time at error occurrence W5905: Year and month of occurrence (Bit 0 to 3: Month, Bit 4 to 15: Year) W5906: Date and time of occurrence (Bit 0 to 5: Minute, Bit 6 to 10: Hour, Bit 11 to 15: Day)
W5907 to W5913	Fault record 2	Read	
W5914 to W5920	Fault record 3	Read	
W5921 to W5927	Fault record 4	Read	
W5928 to W5934	Fault record 5	Read	
W5935 to W5941	Fault record 6	Read	
W5942 to W5948	Fault record 7	Read	
W5949 to W5955	Fault record 8	Read	
W5956 to W5962	Fault record 9	Read	
W5963 to W5969	Fault record 10	Read	

- Preventive maintenance data

Register	Definition	Read/write	Remarks
W6000	Control method	Read	H02: V/F control H04: Advanced magnetic flux vector control H08: Real sensorless vector control H09: Vector control H18: PM sensorless vector control

- Model information monitor

Register	Definition	Read/write	Remarks
W8001	Model (1st and 2nd characters)	Read	The inverter model can be read in ASCII code. "H20" (blank code) is set for blank area. Example) FR-E820-EPA: H46, H52, H2D, H45, H38, H32, H30, H2D, H45, H50, H41, H20...H20
W8002	Model (3rd and 4th characters)	Read	
W8003	Model (5th and 6th characters)	Read	
W8004	Model (7th and 8th characters)	Read	
W8005	Model (9th and 10th characters)	Read	
W8006	Model (11th and 12th characters)	Read	
W8007	Model (13th and 14th characters)	Read	
W8008	Model (15th and 16th characters)	Read	
W8009	Model (17th and 18th characters)	Read	
W8010	Model (19th and 20th characters)	Read	
W8011	Capacity (1st and 2nd characters)	Read	The capacity in the inverter model can be read in ASCII code. Data is read in increments of 0.1 kW, and rounds down to 0.01 kW increments. "H20" (blank code) is set for blank area. Example) 0.75K: " 7" (H20, H20, H20, H20, H20, H37)
W8012	Capacity (3rd and 4th characters)	Read	
W8013	Capacity (5th and 6th characters)	Read	

- Serial number

Register	Definition	Read/write	Remarks
W8101	Serial number (1st and 2nd characters)	Read	The serial number can be read in ASCII code.
W8102	Serial number (3rd and 4th characters)	Read	
W8103	Serial number (5th and 6th characters)	Read	
W8104	Serial number (7th and 8th characters)	Read	
W8105	Serial number (9th and 10th characters)	Read	
W8106	Serial number (11th and 12th characters)	Read	
W8107	Serial number (13th and 14th characters)	Read	
W8108	Serial number (15th and 16th characters)	Read	

NOTE

- When a 32-bit parameter setting or monitor item is read and the value to be read exceeds HFFFF, HFFFF is returned.

◆ Data specified in the command

- Device code

A one byte numerical value is sent.

- Device No. (first device No.) specification

The device No. is specified for reading/writing data.

When consecutive devices are specified, the first device No. is specified. The device No. is specified in decimal or hexadecimal depending on the device type.

A three byte numerical value is sent from the lower byte to the upper byte. If the device No. is a decimal value, convert it to a hexadecimal value.

(Example) Device No. of Internal relay M63 / Input X20

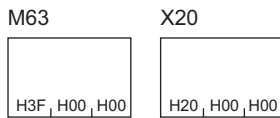

Internal relay M63 has a decimal device No. Convert the decimal value to a hexadecimal value H00003F. The value is sent in the order 3F, 00, and 00. The device No. of Input X20 is regarded as H000020 and sent in the order 20, 00, and 00.

- Specification of the number of devices

The number of devices is specified for reading/writing data.

A two byte numerical value is sent from the lower byte to the upper byte.

(Example) Number of devices: 5 / 20

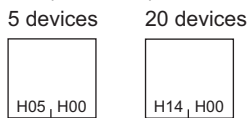

- Specification of the number of devices for bit access

The number of devices is specified for reading/writing data in bit units. The number is used in the Write Random command (refer to [page 140](#)).

(Example) Number of devices: 5 / 20

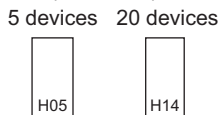

- Read data / write data

The value read from the device is stored for reading. The value to be written to the device is stored for writing.

The data is arranged differently between reading/writing in bit units (subcommand: H0001) and reading/writing in word units (subcommand: H0000).

- In bit units (subcommand: H0001)

Each device is specified in 4 bits. The data is sent from the upper bit for the device with the first device No. and the subsequent devices in order. The ON state is denoted as 1 and the OFF state is denoted as 0.

(Example) ON/OFF state of five devices starting from M10

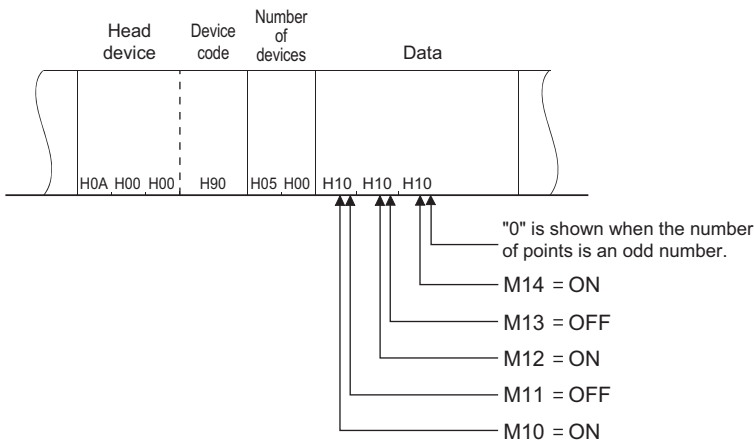

- In word units (subcommand: H0000)

When bit devices are used as word data, each device is specified in one bit. The data is stored from the lower byte (bit 0 to bit 7) to the upper byte (bit 8 to bit 15).

(Example) ON/OFF state of 32 devices starting from M16

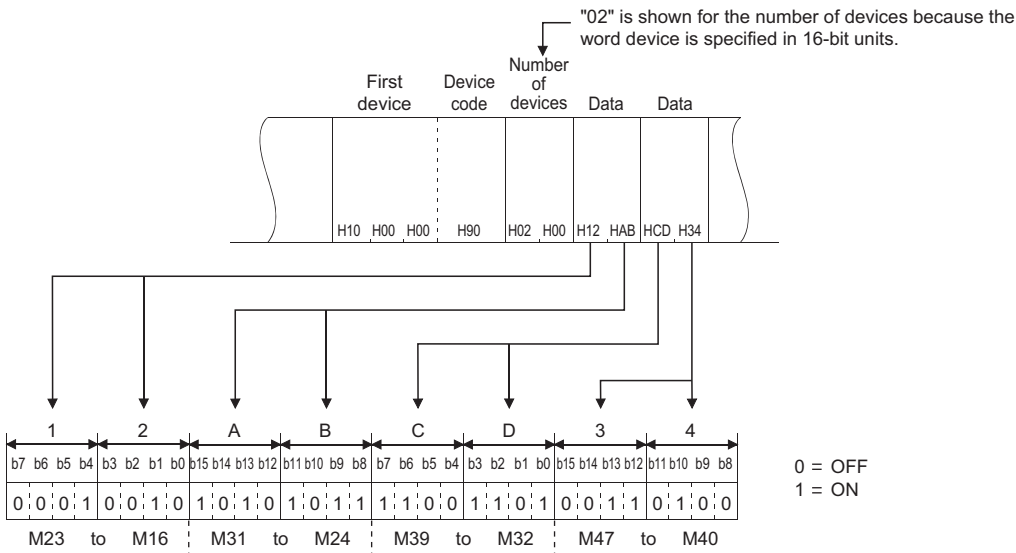

When word devices are used, one word is specified in 16 bits as follows. The data is stored from the lower byte (bit 0 to bit 7) to the upper byte (bit 8 to bit 15).

The user should switch the values in the upper and lower bytes in the response data for reading.

The user should switch the write values in the upper and lower bytes to store them in the request data for writing.

(Example) Data stored in D50/D51

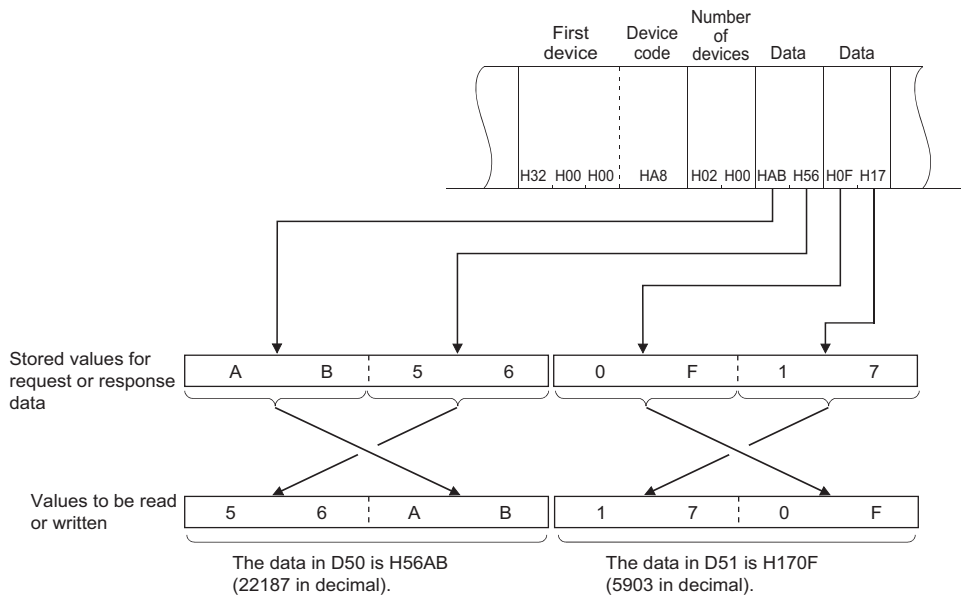

◆ Details of commands

- Read
 The inverter reads the value in the specified devices.
- Request data

H01, H04	Subcommand	First device No.	Device code	Number of devices
----------	------------	------------------	-------------	-------------------

Item	Description
Subcommand	Specify the unit (bit/word) for reading.
First device No.	Specify the number of the first device. (Refer to page 137.)
Device code	Specify the type of target devices. (Refer to page 132.)
Number of devices	Specify the number of target devices.

- Response data
 The value read from the device is stored in hexadecimal.
- Write
 The inverter writes the value to the specified devices.
- Request data

H01, H14	Subcommand	First device No.	Device code	Number of devices	Write data
----------	------------	------------------	-------------	-------------------	------------

Item	Description
Subcommand	Specify the unit (bit/word) for writing.
First device No.	Specify the number of the first device. (Refer to page 137.)
Device code	Specify the type of the target devices. (Refer to page 132.)
Number of devices	Specify the number of target devices.
Data to be written	Specify the value to be written to all the devices specified by the Number of devices in the request data.

- Response data
 None
- Read Random
 The inverter reads the value in the devices with the specified numbers. The devices with non-consecutive numbers can be specified.
- Request data

Specify the devices for the specified number of devices.

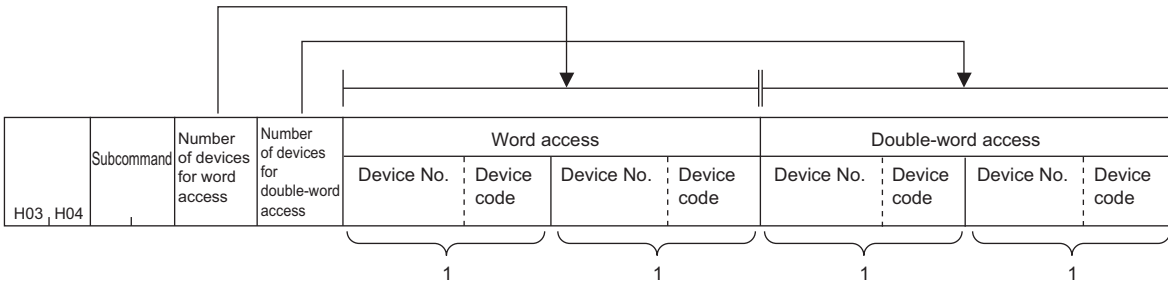

Item	Description
Subcommand	Specify the unit (bit/word) for reading.
Number of devices for word access	Specify the number of devices for one-word access. (bit device: 16 bits, word device: one word)
Number of devices for double-word access	Specify the number of devices for two-word access. (bit device: 32 bits, word device: two words)
Word access	Specify the devices according to the number set in the request data for word access. It is not necessary to specify the devices when "0" is set.
Double-word access	Specify the devices according to the number set in the request data for double word access. It is not necessary to specify the devices when "0" is set.
Device No.	Specify the device number of target devices. (Refer to page 137.)
Device code	Specify the type of target devices. (Refer to page 132.)

• Response data

The value read from the device is stored in hexadecimal.

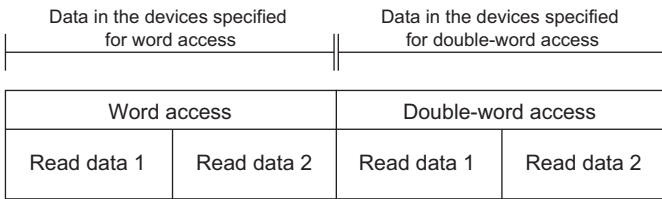

• Write Random

The inverter writes the value in the devices with the specified numbers. The devices with non-consecutive numbers can be specified.

• Request data

Writing data in bit units

Specify the devices for the specified number of devices.

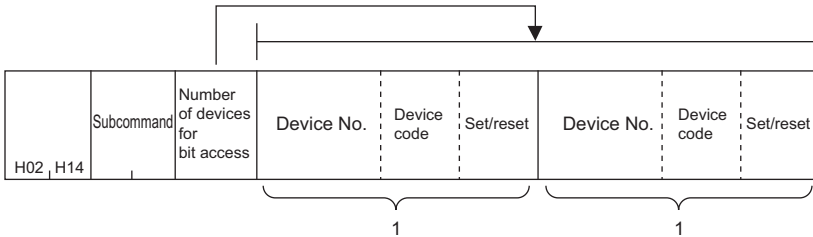

Writing data in word units

Specify the devices for the specified number of devices.

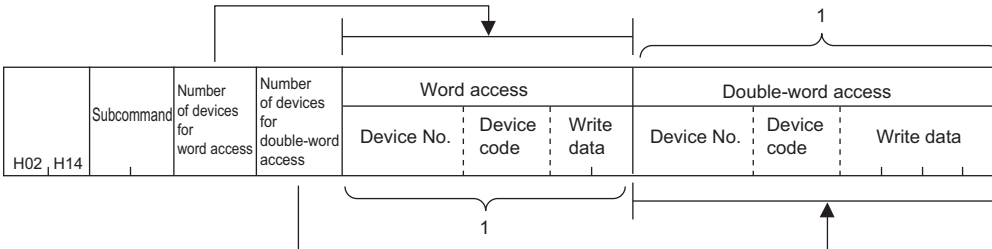

Specify the devices for the specified number of devices.

Item	Description
Subcommand	Specify the unit (bit/word) for writing.
Number of devices for bit access	Specify the number of target devices.
Number of devices for word access	
Number of devices for double-word access	
Word access	Specify the devices according to the number set in the request data for word access. It is not necessary to specify the devices when "0" is set.
Double-word access	Specify the devices according to the number set in the request data for double word access. It is not necessary to specify the devices when "0" is set.
Device No.	Specify the device number of target devices. (Refer to page 137.)
Device code	Specify the type of the target devices. (Refer to page 132.)
Set/reset	Specify ON/OFF of the bit devices. <ul style="list-style-type: none"> • ON: H01 • OFF: H00

- Response data
None
- Remote Run
Remote Run is performed to the inverter.
- Request data

H01, H10	H00, H00	Mode	Clear mode	H00
----------	----------	------	------------	-----

Item	Description	
Mode	Forced execution of the remote RUN is not allowed.	H0100
	Forced execution of the remote RUN is allowed.	H0300
Clear mode	Devices are not cleared (initialized).	H00
	Devices are cleared.	H01, H02

- Response data
None
- Remote Stop
Remote Stop is performed to the inverter.
- Request data

H02, H10	H00, H00	H01, H00
----------	----------	----------

- Response data
None
- Read Type Name
The model name and model code of the inverter are read.
- Request data

H01, H01	H00, H00
----------	----------

- Response data

Model	Model code
-------	------------

Item	Description
Model	The inverter model is stored. Up to 16 characters can be stored. If the model name is shorter than 16 characters, a space (H20) is stored instead of a character. (Example) FR-E800-E inverter: FR-E800-E
Model code	Fixed to H054F

◆ Error code

When the end code is other than "0" (failed completion), one of the error codes shown in the following table will be stored.

Error code	Error description
H4031	The device outside of the range is specified.
H4080	Request data fault
H4A01	The network with the No. set in the routing parameter does not exist. (The destination network No., destination station No., or destination unit I/O No. is different from that of the target inverter.)
HC059	The command or subcommand is specified incorrectly. Or, an unspecified command is received.
HC05B	The inverter cannot read/write data from/to the specified device.
HC05C	The request message has an error.
HC060	The requested operation has an error. Example) Data is specified incorrectly for the bit device.
HC061	The request data length is inconsistent with the number of data.
HCEE1	The request message size exceeds the allowable range.
HCEE2	The response message size exceeds the allowable range.

2.11 EtherNet/IP

2.11.1 Outline

EtherNet/IP®

EtherNet/IP is available for the FR-E800-(SC)EPA and FR-E806-SCEPA.

When the EtherNet/IP communication operation is performed through the Ethernet connector on the inverter, data such as parameters, command values, and feedback values are regarded as objects used for data communication between a master and inverters. Objects consist of the Class ID, object name, data type, access rule, etc. I/O message communication (cyclic) and explicit message communication (message) are available.

Some functions are not supported depending on the date of manufacture of the inverter. For details of specification changes, refer to [page 290](#).

◆ Communication specifications

Item	Description	
Maximum number of branches	No upper limit on the same Ethernet network	
Connection cable	Ethernet cable (IEEE 802.3 100BASE-TX/10BASE-T compliant cable and ANSI/TIA/EIA-568-B (Category 5e) compliant shielded 4-pair branched cable)	
Topology	Line, star, or a combination of line and star	
Class 1 communication (I/O Message communication)	Communication method	Cyclic communication
	Number of connections	4
	Communication data size	For details, refer to description of Assembly Object (page 151).
	Connection type (inverter to master)	Unicast or multicast
	Connection type (master to inverter)	Unicast
	Exclusive Owner connection	Connection point (inverter to master): Assembly input instance
		Connection point (master to inverter): Assembly output instance
	Input Only connection	Connection point (inverter to master): Assembly input instance
		Connection point (master to inverter): Assembly heartbeat instance (C5h)
	Listen Only connection	Connection point (inverter to master): Assembly input instance
Connection point (master to inverter): Assembly heartbeat instance (C6h)		
RPI (cycle time)	4 to 100 ms	
Supported trigger type	Cyclic (repeated)	
Class 3 communication (Explicit Message communication)	Communication method	Message communication
	Number of connections	2
	Connection type (inverter to master)	Unicast
	Connection type (master to inverter)	Unicast
UCMM communication (Explicit Message communication)	Communication method	Message communication
	Number of connections	2
	Connection type (inverter to master)	Unicast
	Connection type (master to inverter)	Unicast
Conformity test	CT16	

◆ Operation status LEDs

LED name	Description	LED status	Remarks
NS	Communication status	OFF	Power-OFF / IP address not set
		Blinking green	Online, no connections established
		Solid green	Online, connections established
		Blinking red	Exclusive Owner connection timeout
MS	Inverter status	OFF	Power-OFF / during inverter reset
		Blinking green	Not set (status other than those indicated by OFF, solid green, blinking red, and solid red of the MS LED)
		Solid green	Operating properly (All I/O communications are in run state and Exclusive Owner connection state.)
		Blinking red	Warning or alarm output
		Solid red	Fault detected
LINK1	Connector for communication (PORT1) status	OFF	Power-OFF/link-down
		Blinking green	Link-up (Data reception in progress)
		Solid green	Link-up
LINK2	Connector for communication (PORT2) status	OFF	Power-OFF/link-down
		Blinking green	Link-up (Data reception in progress)
		Solid green	Link-up

◆ EDS file

An EDS file is available for download.

Mitsubishi Electric FA Global Website:

www.mitsubishielectric.com/fa/products/drv/inv/support/e800/network.html

The download is free at the website above. For details, contact your sales representative.

Use an appropriate EDS file for the inverter as specified in the following table. Errors may occur due to engineering software operation.

NOTE

- The EDS file is used in engineering software. To install the EDS file properly, refer to the instruction manual of the applicable engineering software.

2.11.2 EtherNet/IP configuration

◆ Procedure

The procedure differs depending on the master device and the engineering software used. For details, refer to the Instruction Manual of the master device and the engineering software.

■ Before communication

1. Connect each unit with an Ethernet cable. (Refer to [page 15.](#))
2. Set "44818" (EtherNet/IP) in any of **Pr.1427 to Pr.1430 Ethernet function selection 1 to 4.** (Refer to [page 145.](#))
(Example: **Pr.1429** = "45238" (CC-Link IE TSN) (initial value) → "44818" (EtherNet/IP))
When **Pr.1429** = "45238 (initial value)" (CC-Link IE TSN), change the value to "44818" (EtherNet/IP). When "45238" is set in any of **Pr.1427 to Pr.1430**, the priority is given to CC-Link IE TSN, disabling EtherNet/IP.
3. Reset the inverter, or turn OFF and then ON the power.

■ Network configuration

1. Add the downloaded EDS file to the engineering software.
2. Detect the inverters on the network using the engineering software.
3. Add the detected inverters to the network configuration settings.
4. Configure the module settings for the inverters.
Set the device name for each inverter when two or more inverters are connected.

■ Checking communication

The following table shows the status of the LEDs when communication is established between the programmable controller and the inverter.

NS	MS	LINK1	LINK2
Solid green	Solid green	Blinking green ^{*1}	

*1 The LED on either LINK1 or LINK2 will blink depending on the port (port 1 or 2) the Ethernet cable is connected to.

2.11.3 Initial setting for EtherNet/IP

Use the following parameters to perform required settings for Ethernet communication between the inverter and other devices. To make communication between other devices and the inverter, perform the initial settings of the inverter parameters to match the communication specifications of the devices. Data communication cannot be made if the initial settings are not configured or if there is any setting error.

Pr.	Name	Initial value	Setting range	Description
1427 N630 ^{*1}	Ethernet function selection 1	5001	502, 5000 to 5002, 5006 to 5008, 5010 to 5013, 9999, 44818, 45237, 45238, 47808, 61450	Set the application, protocol, etc.
1428 N631 ^{*1}	Ethernet function selection 2	45237		
1429 N632 ^{*1}	Ethernet function selection 3	45238		
1430 N633 ^{*1}	Ethernet function selection 4	9999		
1432 N644	Ethernet communication check time interval	1.5 s	0	Ethernet communication is available, but the inverter output is shut off in the NET operation mode.
			0.1 to 999.8 s	Set the interval of the communication check (signal loss detection) time for all devices with IP addresses in the range specified for Ethernet command source selection (Pr.1449 to Pr.1454).
			9999	If a no-communication state persists for longer than the permissible time, the inverter output will be shut off. No communication check (signal loss detection)
1449 N670 ^{*1}	Ethernet command source selection IP address 1	0	0 to 255	To limit the network devices that send the operation or speed command through the Ethernet network, set the range of IP addresses of the devices. When Pr.1449 to Pr.1452 = "0 (initial value)", no IP address is specified for command source selection via Ethernet. In this case, operation commands cannot be sent via Ethernet.
1450 N671 ^{*1}	Ethernet command source selection IP address 2	0		
1451 N672 ^{*1}	Ethernet command source selection IP address 3	0		
1452 N673 ^{*1}	Ethernet command source selection IP address 4	0		
1453 N674 ^{*1}	Ethernet command source selection IP address 3 range specification	9999	0 to 255, 9999	
1454 N675 ^{*1}	Ethernet command source selection IP address 4 range specification	9999		

*1 The setting is applied after an inverter reset or next power-ON.

NOTE

- The monitor items and parameter settings can be read during communication with the **Pr.1432 Ethernet communication check time interval** = "0 (initial value)" setting, but such operation will become faulty once the operation mode is changed to the NET operation mode. When the NET operation mode is selected as the start-up operation mode, communication is performed once, then an Ethernet communication fault (E.EHR) occurs.
- To perform operation or parameter writing via communication, set **Pr.1432** to "9999" or a value larger than the communication cycle or retry time setting. (Refer to [page 146](#).)

◆ Ethernet function selection (Pr.1427 to Pr.1430)

To select EtherNet/IP for the application, set "44818" (EtherNet/IP) in any of **Pr.1427 to Pr.1430 Ethernet function selection 1 to 4**. When **Pr.1429** = "45238 (initial value)" (CC-Link IE TSN), change the value to "44818" (EtherNet/IP). When "45238" is set in any of **Pr.1427 to Pr.1430**, the priority is given to CC-Link IE TSN, disabling EtherNet/IP.

NOTE

- Change the setting if selected communication protocols cannot be used together. (Refer to [page 7](#) and [page 226](#).)

◆ Ethernet IP address for command source selection (Pr.1449 to Pr.1454)

- To limit the network devices that send the operation or speed command through the Ethernet network, set the range of IP addresses of the devices.
- When **Pr.1449 to Pr.1452** = "0 (initial value)", no IP address is specified for command source selection via Ethernet. In this case, operation commands cannot be sent via Ethernet.
- The setting range for command source selection depends on the settings in **Pr.1451** and **Pr.1453**, and **Pr.1452** and **Pr.1454**. (Either of the settings can be larger than the other in **Pr.1451** and **Pr.1453**, and **Pr.1452** and **Pr.1454**.)

[Setting example 1]

Configuration

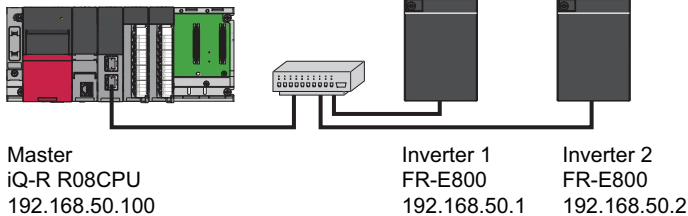

To allow the master to control the inverters, set the parameters in inverters 1 and 2 as follows to specify the IP address range for Ethernet command source selection.

Set the IP address of the master in the engineering software (GX Works3) within the range from 192.168.50.100 to 192.168.50.110.

	Pr.1449	Pr.1450	Pr.1451	Pr.1452
Ethernet IP address for command source selection	192	168	50	100
Command source selection range setting for the Ethernet IP address	—	—	9999	110

The range is between the values set in both parameters.

In this case, the IP address range in which Ethernet communication is permitted is "192.168.50.xxx (100 to 110)".

[Setting example 2]

	Pr.1449	Pr.1450	Pr.1451	Pr.1452
Ethernet IP address for command source selection	192	168	1	100
Command source selection range setting for the Ethernet IP address	—	—	3	150

The range is between the values set in both parameters.

The range is between the values set in both parameters.

In this case, the IP address range for command source selection via Ethernet communication is "192.168.x (1 to 3).xxx (100 to 150)".

- When "9999 (initial value)" is set in **Pr.1453** or **Pr.1454**, the range is invalid.

◆ Ethernet communication check time interval (Pr.1432)

- If a signal loss (communication stop) is detected between the inverter and all the devices with IP addresses in the range for Ethernet command source selection (**Pr.1449 to Pr.1454**) as a result of a signal loss detection, a communication error (E.EHR) occurs and the inverter output will be shut off.
- When "9999" is set in **Pr.1432**, the communication check (signal loss detection) will not be performed.

- The monitor items and parameter settings can be read via Ethernet when "0" is set in **Pr.1432**, but a communication error (E.EHR) occurs instantly when the operation mode is switched to the Network operation.
- A signal loss detection is made when any of 0.1 s to 999.8 s is set in **Pr.1432**. In order to enable the signal loss detection, data must be sent by connected devices at an interval equal to or less than the time set for the communication check. (The inverter makes a communication check (clearing of communication check counter) regardless of the station number setting of the data sent from the master).
- Communication check is started at the first communication when the inverter operates in the Network operation mode and the command source is specified as communication via the Ethernet connector.

Example) When **Pr.1432** = 0.1 to 999.8 s

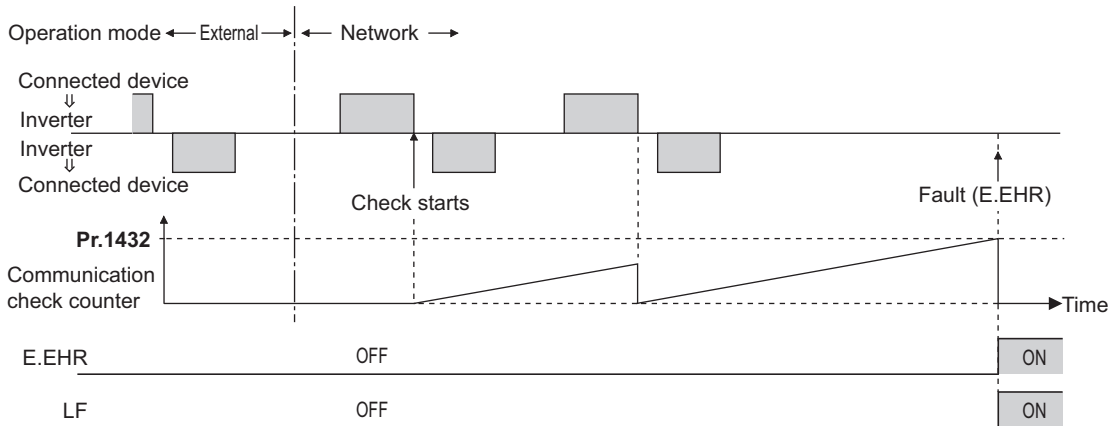

2.11.4 Parameters related to EtherNet/IP

The following parameters are used for EtherNet/IP communication. Set the parameters as required.

Pr.	Name	Initial value	Setting range	Description
541 N100	Frequency command sign selection	0	0	Signed frequency command value
			1	Unsigned frequency command value
1426 N641 ^{*1}	Link speed and duplex mode selection	0	0 to 4	Set the communication speed and the communication mode (full-duplex/half-duplex).
1442 N660 ^{*1}	IP filter address 1 (Ethernet)	0	0 to 255	Set the range of connectable IP addresses for the network devices. (When Pr.1442 to Pr.1445 = "0 (initial value)", the function is invalid.)
1443 N661 ^{*1}	IP filter address 2 (Ethernet)	0		
1444 N662 ^{*1}	IP filter address 3 (Ethernet)	0		
1445 N663 ^{*1}	IP filter address 4 (Ethernet)	0		
1446 N664 ^{*1}	IP filter address 2 range specification (Ethernet)	9999	0 to 255, 9999	
1447 N665 ^{*1}	IP filter address 3 range specification (Ethernet)	9999		
1448 N666 ^{*1}	IP filter address 4 range specification (Ethernet)	9999		
1318 N800 ^{*1}	User Defined Cyclic Communication Input fixing format selection	9999	20 to 23	Set the output assembly instance number of Assembly Object (04h). Users can assign a function to the configurable output instance.
			9999	Function disabled
1319 N801 ^{*1}	User Defined Cyclic Communication Output fixing format selection	9999	70 to 73	Set the input assembly instance number of Assembly Object (04h). Users can assign a function to the configurable input instance.
			9999	Function disabled

Pr.	Name	Initial value	Setting range	Description
1320 to 1329 N810 to N819*1	User Defined Cyclic Communication Input 1 to 10 Mapping	9999	12288 to 13787, 20488, 20489, 24672, 24689, 24698, 24703, 24705, 24707, 24708, 24719, 24721, 24728 to 24730	Set the instance number of Inverter Configuration Object (64h) or the index number of CiA402 drive profile. Users can assign a function to the configurable output instance.
			9999	Function disabled
1330 to 1343 N850 to N863*1	User Defined Cyclic Communication Output 1 to 14 Mapping	9999	12288 to 13787, 16384 to 16483, 20488, 20489, 20981 to 20990, 20992 ² , 24639, 24643, 24644, 24673 to 24676, 24692, 24695, 24820, 24826, 24828, 25858	Set the instance number of Inverter Configuration Object (64h) or the index number of CiA402 drive profile. Users can assign a function to the configurable input instance.
			9999	Function disabled
1389*1	User Defined Cyclic Communication Input Sub 1 and 2 Mapping	0	0 to 2, 256 to 258, 512 to 514	Pr.1389 (lower 8 bits): Subindex to which the instance/index number is specified using Pr.1320 Pr.1389 (upper 8 bits): Subindex to which the instance/index number is specified using Pr.1321
1390*1	User Defined Cyclic Communication Input Sub 3 and 4 Mapping	0	0 to 2, 256 to 258, 512 to 514	Pr.1390 (lower 8 bits): Subindex to which the instance/index number is specified using Pr.1322 Pr.1390 (upper 8 bits): Subindex to which the instance/index number is specified using Pr.1323
1391*1	User Defined Cyclic Communication Input Sub 5 and 6 Mapping	0	0 to 2, 256 to 258, 512 to 514	Pr.1391 (lower 8 bits): Subindex to which the instance/index number is specified using Pr.1324 Pr.1391 (upper 8 bits): Subindex to which the instance/index number is specified using Pr.1325
1392*1	User Defined Cyclic Communication Input Sub 7 and 8 Mapping	0	0 to 2, 256 to 258, 512 to 514	Pr.1392 (lower 8 bits): Subindex to which the instance/index number is specified using Pr.1326 Pr.1392 (upper 8 bits): Subindex to which the instance/index number is specified using Pr.1327
1393*1	User Defined Cyclic Communication Input Sub 9 and 10 Mapping	0	0 to 2, 256 to 258, 512 to 514	Pr.1393 (lower 8 bits): Subindex to which the instance/index number is specified using Pr.1328 Pr.1393 (upper 8 bits): Subindex to which the instance/index number is specified using Pr.1329
N830 to N839*1	User Defined Cyclic Communication Input Sub 1 to 10 Mapping	0	0 to 2	Subindices to which the instance/index numbers are specified using Pr.1320 to Pr.1329
1394*1	User Defined Cyclic Communication Output Sub 1 and 2 Mapping	0	0 to 2, 256 to 258, 512 to 514	Pr.1394 (lower 8 bits): Subindex to which the instance/index number is specified using Pr.1330 Pr.1394 (upper 8 bits): Subindex to which the instance/index number is specified using Pr.1331
1395*1	User Defined Cyclic Communication Output Sub 3 and 4 Mapping	0	0 to 2, 256 to 258, 512 to 514	Pr.1395 (lower 8 bits): Subindex to which the instance/index number is specified using Pr.1332 Pr.1395 (upper 8 bits): Subindex to which the instance/index number is specified using Pr.1333
1396*1	User Defined Cyclic Communication Output Sub 5 and 6 Mapping	0	0 to 2, 256 to 258, 512 to 514	Pr.1396 (lower 8 bits): Subindex to which the instance/index number is specified using Pr.1334 Pr.1396 (upper 8 bits): Subindex to which the instance/index number is specified using Pr.1335
1397*1	User Defined Cyclic Communication Output Sub 7 and 8 Mapping	0	0 to 2, 256 to 258, 512 to 514	Pr.1397 (lower 8 bits): Subindex to which the instance/index number is specified using Pr.1336 Pr.1397 (upper 8 bits): Subindex to which the instance/index number is specified using Pr.1337
1398*1	User Defined Cyclic Communication Output Sub 9 and 10 Mapping	0	0 to 2, 256 to 258, 512 to 514	Pr.1398 (lower 8 bits): Subindex to which the instance/index number is specified using Pr.1338 Pr.1398 (upper 8 bits): Subindex to which the instance/index number is specified using Pr.1339
N870 to N879*1	User Defined Cyclic Communication Output Sub 1 to 10 Mapping	0	0 to 2	Subindices to which the instance/index numbers are specified using Pr.1330 to Pr.1339

*1 The setting is applied after an inverter reset or next power-ON.

◆ Frequency command with sign (Pr.541)

- The start command (forward/reverse rotation) can be inverted by adding a plus or minus sign to the value of the frequency command sent through the EtherNet/IP.
- The **Pr.541 Frequency command sign selection** setting is applied to SpeedRef (attribute 8) of AC/DC Drive Object (2Ah). (Refer to [page 157.](#))

Pr.541 setting	Sign
0	Without
1	With

- Relationship between the start command and sign (**Pr.541 = "1"**)

Start command	Sign of the frequency command	Actual operation command
Forward rotation	+	Forward rotation
	-	Reverse rotation
Reverse rotation	+	Reverse rotation
	-	Forward rotation

◆ Communication speed and full-duplex/half-duplex selection (Pr.1426)

Use **Pr.1426 Link speed and duplex mode selection** to set the communication speed and the full-duplex or half-duplex system. If the operation is not performed properly in the initial setting (**Pr.1426 = "0"**), set **Pr.1426** according to the specifications of the connected device.

Pr.1426 setting	Communication speed	Full-duplex/half-duplex system	Remarks
0 (initial value)	Automatic negotiation	Automatic negotiation	The communication speed and the communication mode (half-duplex/full-duplex) are automatically negotiated to ensure the optimum setting. To set automatic negotiation, auto negotiation setting is required also in the master station.
1	100 Mbps	Full duplex	—
2	100 Mbps	Half duplex	—
3	10 Mbps	Full duplex	—
4	10 Mbps	Half duplex	—

◆ IP filtering function (Ethernet) (Pr.1442 to Pr.1448)

- Set the IP address range for connectable network devices (**Pr.1442 to Pr.1448**) to limit the connectable devices. The setting range for IP address of connectable network devices depends on the settings in **Pr.1443** and **Pr.1446**, **Pr.1444** and **Pr.1447**, and **Pr.1445** and **Pr.1448**. (Either of the settings can be larger than the other in **Pr.1443** and **Pr.1446**, **Pr.1444** and **Pr.1447**, and **Pr.1445** and **Pr.1448**.)

[Setting example 1]

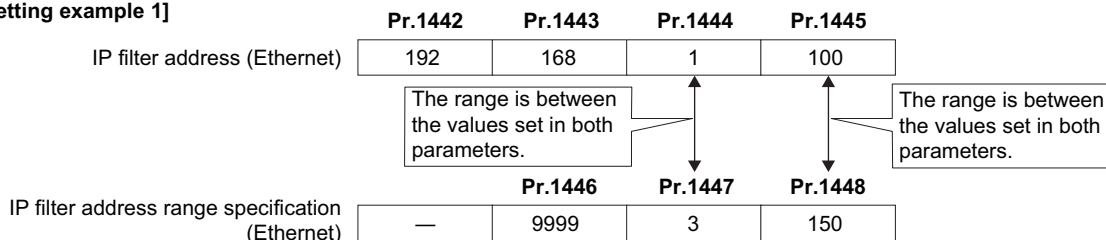

In this case, the IP address range in which Ethernet communication is permitted is "192.168.x (1 to 3).xxx (100 to 150)".

[Setting example 2]

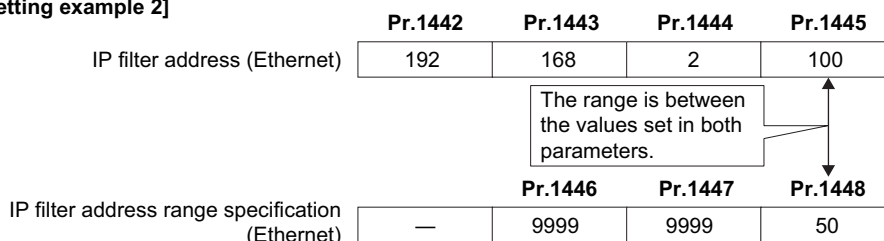

In this case, the IP address range in which Ethernet communication is permitted is "192.168.2.xxx (50 to 100)".

- When **Pr.1442 to Pr.1445** = "0 (initial value)", the function is invalid.
- When "9999 (initial value)" is set in **Pr.1446 to Pr.1448**, the range is invalid.

⚠ CAUTION

- The IP filtering function (Ethernet) (**Pr.1442 to Pr.1448**) is provided as a means to prevent unauthorized access, DoS attacks, computer viruses, or other cyberattacks from external devices, but the function does not prevent such access completely. In order to protect the inverter and the system against unauthorized access by external systems, take additional security measures. We shall have no responsibility or liability for any problems involving inverter trouble and system trouble by DoS attacks, unauthorized access, computer viruses, and other cyberattacks. The following are examples of measures to prevent them.
 - Install a firewall.
 - Install a personal computer as a relay station, and control the relaying of transmission data using an application program.
 - Install an external device as a relay station to control access rights. (For the details of external devices used to control access rights, contact the distributors of the external devices.)

2.11.5 Object map definitions

◆ Object model of EtherNet/IP communication

For EtherNet/IP communication, each node is modeled as collections of objects (abstraction of particular functions of the products). The following four terms are used to describe object.

Item	Description
Class	Collections of all objects which have same types of functions. Generalization of object.
Instance	Concrete expression of object.
Attribute	Expression of object characteristic.
Service	Function supported by object or class.

2.11.6 Object map

◆ Identity-Object (01h)

This object shows general information of the device.

■ Service

Class	Instance
Get_Attribute_Single Get_Attributes_All	Get_Attribute_Single Set_Attribute_Single Get_Attributes_All Reset ^{*1} (inverter reset)

*1 Writing is restricted by the settings of Ethernet IP address for command source selection (**Pr.1449 to Pr.1454**).

■ Class attribute

No.	Name	Access	Type	Description
1	Revision	Get	UINT	0001h (Revision of the object)

■ Instance 1 attributes

No.	Name	Access	Type	Description
1	Vendor ID	Get	UINT	00A1h (Mitsubishi Electric)
2	Device Type	Get	UINT	0002h (AC Drive)
3	Product Code	Get	UINT	003Eh (Product code)
4	Revision	Get	Structure	Major revision and minor revision
	Major revision		USINT	0001h (Major revision number)
	Minor revision		USINT	0001h (Minor revision number)
5	Status	Get	WORD	Refer to "Status (Attribute 5)" on page 151 .
6	Serial Number	Get	UDINT	Serial number of the inverter ^{*1}
7	Product Name	Get	SHORT_STRING	FR-E800-(SC)E (product name)

No.	Name	Access	Type	Description
11	Active language	Set/Get	Structure	Active language
			USINT	e, n, g (English)
			USINT	
			USINT	
12	Supported Language List	Get	Structure array	List of languages supported by the host application
			USINT	e, n, g (English)
			USINT	
			USINT	

*1 The number is created from the MAC address and used for EtherNet/IP communication. This is not the SERIAL number printed on the rating plate or on the package of the inverter.

- Status (Attribute 5)

Bit	Name	Description
0	Module Owned	CIP connection established
1	—	Fixed to 0
2	Configured	Fixed to 1 (configured)
3	—	Fixed to 0
4 to 7	Extended Device Status	0000b: Unknown 0010b: Faulted I/O Connection (Exclusive Owner connection timed out) 0011b: No I/O connection establish (I/O connection not established) 0100b: Non volatile configuration bad 0101b: Major fault (Bit 10 = 1) 0110b: Connection in Run mode (I/O connection established, with Run mode connection) 0111b: Connection in Idle mode (I/O connection established)
8	Minor Recoverable Fault	Warning or alarm
9	Minor Unrecoverable Fault	Fixed to 0
10	Major Recoverable Fault	Fault
11	Major Unrecoverable Fault	Fixed to 0
12 to 15	—	Fixed to 0

◆ Assembly Object (04h)

The Assembly object uses static assemblies and holds the Process Data sent/received by the inverter. Instance 20 to 23 and 70 to 73 are predefined for specific drive profile parameters. Users can select communication data using Instance 100 and 150.

■ Service

Class	Instance
Get_Attribute_Single	Get_Attribute_Single Set_Attribute_Single

■ Class attribute

No.	Name	Access	Type	Description
1	Revision	Get	UINT	0002h (Revision of the object)
2	Max Instance	Get	UINT	(Highest instance number)

■ Instance attribute

No.	Name	Access	Type	Description
3 ^{*1}	Data	Set/Get	USINT array	Inverter I/O data

*1 The number corresponds to the instance number described in the output/input assembly.

■ Output assemblies (Consuming instances)

For definitions and mapping of data in this instance, refer to the data definitions of output assemblies on [page 153](#).

Writing is restricted by the settings of Ethernet IP address for command source selection (**Pr.1449 to Pr.1454**).

- Instance 20 (14h) - Basic Speed Control Output

Byte	Bit 7	Bit 6	Bit 5	Bit 4	Bit 3	Bit 2	Bit 1	Bit 0
0	0	0	0	0	0	Fault reset	0	Run fwd
1	00h							

Byte	Bit 7	Bit 6	Bit 5	Bit 4	Bit 3	Bit 2	Bit 1	Bit 0
2	Speed reference (Low byte)							
3	Speed reference (High byte)							

- Instance 21 (15h) - Extended Speed Control Output

Byte	Bit 7	Bit 6	Bit 5	Bit 4	Bit 3	Bit 2	Bit 1	Bit 0
0	0	NetRef	NetCtrl	0	0	Fault reset	Run rev	Run fwd
1	00h							
2	Speed reference (Low byte)							
3	Speed reference (High byte)							

- Instance 22 (16h) - Speed and Torque Control Output

Byte	Bit 7	Bit 6	Bit 5	Bit 4	Bit 3	Bit 2	Bit 1	Bit 0
0	0	0	0	0	0	Fault reset	0	Run fwd
1	00h							
2	Speed reference (Low byte)							
3	Speed reference (High byte)							
4	Torque reference (Low byte)							
5	Torque reference (High byte)							

- Instance 23 (17h) - Extended Speed and Torque Control Output

Byte	Bit 7	Bit 6	Bit 5	Bit 4	Bit 3	Bit 2	Bit 1	Bit 0
0	0	NetRef	NetCtrl	0	0	Fault reset	Run rev	Run fwd
1	00h							
2	Speed reference (Low byte)							
3	Speed reference (High byte)							
4	Torque reference (Low byte)							
5	Torque reference (High byte)							

- Instance 100 (64h): Configurable Output

The data length depends on the settings in **Pr.1318**, **Pr.1320 to Pr.1329**, and **Pr.1389 to Pr.1393**. (For user defined cyclic communication input data, the data size ranges from 1 to 4 bytes depending on the data type specified in **Pr.1320 to Pr.1329** and **Pr.1389 to Pr.1393**.) When "9999" is set in any of **Pr.1318** and **Pr.1320 to Pr.1329**, the length of the corresponding data is treated as 0 bytes. (When "9999" is set in all of them, communication cannot be established.)

If the same instance/index number is specified in two or more of **Pr.1320 to Pr.1329**, the number set in the parameter with the smallest parameter number is valid. The same number set in the other parameters is regarded as "9999". When a nonexistent instance/index number is set in **Pr.1320 to Pr.1329**, data is not written.

The following format is an example when the data size is 2 bytes for all of the user defined cyclic communication input data.

Byte ^{*1}	Bit 7	Bit 6	Bit 5	Bit 4	Bit 3	Bit 2	Bit 1	Bit 0
0 to (n-1)	User Defined Cyclic Communication Input fixing format selection (Pr.1318)							
n	User Defined Cyclic Communication Input 1 (lower bytes) (Pr.1320)							
n+1	User Defined Cyclic Communication Input 1 (upper bytes) (Pr.1320)							
n+2	User Defined Cyclic Communication Input 2 (lower bytes) (Pr.1321)							
n+3	User Defined Cyclic Communication Input 2 (upper bytes) (Pr.1321)							
n+4	User Defined Cyclic Communication Input 3 (lower bytes) (Pr.1322)							
n+5	User Defined Cyclic Communication Input 3 (upper bytes) (Pr.1322)							
n+6	User Defined Cyclic Communication Input 4 (lower bytes) (Pr.1323)							
n+7	User Defined Cyclic Communication Input 4 (upper bytes) (Pr.1323)							
n+8	User Defined Cyclic Communication Input 5 (lower bytes) (Pr.1324)							
n+9	User Defined Cyclic Communication Input 5 (upper bytes) (Pr.1324)							
n+10	User Defined Cyclic Communication Input 6 (lower bytes) (Pr.1325)							
n+11	User Defined Cyclic Communication Input 6 (upper bytes) (Pr.1325)							
n+12	User Defined Cyclic Communication Input 7 (lower bytes) (Pr.1326)							
n+13	User Defined Cyclic Communication Input 7 (upper bytes) (Pr.1326)							
n+14	User Defined Cyclic Communication Input 8 (lower bytes) (Pr.1327)							
n+15	User Defined Cyclic Communication Input 8 (upper bytes) (Pr.1327)							
n+16	User Defined Cyclic Communication Input 9 (lower bytes) (Pr.1328)							
n+17	User Defined Cyclic Communication Input 9 (upper bytes) (Pr.1328)							
n+18	User Defined Cyclic Communication Input 10 (lower bytes) (Pr.1329)							

Byte ^{*1}	Bit 7	Bit 6	Bit 5	Bit 4	Bit 3	Bit 2	Bit 1	Bit 0
n+19	User Defined Cyclic Communication Input 10 (upper bytes) (Pr.1329)							

*1 "n" indicates the data length of the instance specified in Pr.1318 (4 or 6 bytes).

In Pr.1389 to Pr.1393, specify the subindices to which the instance/index numbers are specified using Pr.1320 to Pr.1329.

Data No.	Instance/index specification	Sub index specification
1	Pr.1320	Pr.1389 (lower 8 bits)
2	Pr.1321	Pr.1389 (upper 8 bits)
3	Pr.1322	Pr.1390 (lower 8 bits)
4	Pr.1323	Pr.1390 (upper 8 bits)
5	Pr.1324	Pr.1391 (lower 8 bits)
6	Pr.1325	Pr.1391 (upper 8 bits)
7	Pr.1326	Pr.1392 (lower 8 bits)
8	Pr.1327	Pr.1392 (upper 8 bits)
9	Pr.1328	Pr.1393 (lower 8 bits)
10	Pr.1329	Pr.1393 (upper 8 bits)

- Data definitions, output assemblies

The following table indicates the mapping of the data in the consuming instances of the Assembly Object. For details, refer to the Control Supervisor Object (29h) on page 156, and AC/DC Drive Object (2Ah) on page 157.

Name	Object		Instance No.	Attribute	
	Name	No.		Name	No.
Run rev	Control Supervisor	29h	1	Run2	4
Run fwd	Control Supervisor	29h	1	Run1	3
Fault reset	Control Supervisor	29h	1	FaultRst	12
NetCtrl	Control Supervisor	29h	1	NetCtrl	5
NetRef	AC/DC Drive	2Ah	1	NetRef	4
Speed reference	AC/DC Drive	2Ah	1	SpeedRef	8
Torque reference	AC/DC Drive	2Ah	1	TorqueRef	12

■ Input assemblies (Producing instances)

For definitions and mapping of data in this instance, refer to the data definitions of input assemblies on page 155.

- Instance 70 (46h) - Basic Speed Control Input

Byte	Bit 7	Bit 6	Bit 5	Bit 4	Bit 3	Bit 2	Bit 1	Bit 0
0	0	0	0	0	0	Running1	0	Faulted
1	00h							
2	Speed actual (Low byte)							
3	Speed actual (High byte)							

- Instance 71 (47h) - Extended Speed Control Input

Byte	Bit 7	Bit 6	Bit 5	Bit 4	Bit 3	Bit 2	Bit 1	Bit 0
0	At reference	Ref from net	Ctrl from net	Ready	Running 2 (Rev)	Running1 (Fwd)	Warning	Faulted
1 ^{*1}	Drive state							
2	Speed actual (Low byte)							
3	Speed actual (High byte)							

*1 For drive states and behavior, refer to the Control Supervisor Object (29h) or the instance attribute on page 156.

- Instance 72 (48h) - Speed and Torque Control Input

Byte	Bit 7	Bit 6	Bit 5	Bit 4	Bit 3	Bit 2	Bit 1	Bit 0
0	0	0	0	0	0	Running1	0	Faulted
1	00h							
2	Speed actual (Low byte)							
3	Speed actual (High byte)							
4	Torque actual (Low byte)							
5	Torque actual (High byte)							

- Instance 73 (49h) - Extended Speed and Torque Control Input

Byte	Bit 7	Bit 6	Bit 5	Bit 4	Bit 3	Bit 2	Bit 1	Bit 0
0	At reference	Ref from net	Ctrl from net	Ready	Running 2 (Rev)	Running1 (Fwd)	Warning	Faulted
1 ^{*1}	Drive state							
2	Speed actual (Low byte)							
3	Speed actual (High byte)							
4	Torque actual (Low byte)							
5	Torque actual (High byte)							

*1 For drive states and behavior, refer to the Control Supervisor Object (29h) or the instance attribute on [page 156](#).

- Instance 150 (96h): Configurable Input

The data length depends on the settings in **Pr.1319**, **Pr.1330 to Pr.1343**, and **Pr.1394 to Pr.1398**. (For user defined cyclic communication output data, the data size ranges from 1 to 4 bytes depending on the data type specified in **Pr.1330 to Pr.1343** and **Pr.1394 to Pr.1398**.) When "9999" is set in any of **Pr.1319** and **Pr.1330 to Pr.1343**, the length of the corresponding data is treated as 0 bytes.

When a nonexistent instance/index number is set in **Pr.1330 to Pr.1343**, "0" is read.

The following format is an example when the data size is 2 bytes for all of the user defined cyclic communication output data.

Byte ^{*1}	Bit 7	Bit 6	Bit 5	Bit 4	Bit 3	Bit 2	Bit 1	Bit 0
0 to (n-1)	User Defined Cyclic Communication Output fixing format selection (Pr.1319)							
n	User Defined Cyclic Communication Output 1 (lower bytes) (Pr.1330)							
n+1	User Defined Cyclic Communication Output 1 (upper bytes) (Pr.1330)							
n+2	User Defined Cyclic Communication Output 2 (lower bytes) (Pr.1331)							
n+3	User Defined Cyclic Communication Output 2 (upper bytes) (Pr.1331)							
n+4	User Defined Cyclic Communication Output 3 (lower bytes) (Pr.1332)							
n+5	User Defined Cyclic Communication Output 3 (upper bytes) (Pr.1332)							
n+6	User Defined Cyclic Communication Output 4 (lower bytes) (Pr.1333)							
n+7	User Defined Cyclic Communication Output 4 (upper bytes) (Pr.1333)							
n+8	User Defined Cyclic Communication Output 5 (lower bytes) (Pr.1334)							
n+9	User Defined Cyclic Communication Output 5 (upper bytes) (Pr.1334)							
n+10	User Defined Cyclic Communication Output 6 (lower bytes) (Pr.1335)							
n+11	User Defined Cyclic Communication Output 6 (upper bytes) (Pr.1335)							
n+12	User Defined Cyclic Communication Output 7 (lower bytes) (Pr.1336)							
n+13	User Defined Cyclic Communication Output 7 (upper bytes) (Pr.1336)							
n+14	User Defined Cyclic Communication Output 8 (lower bytes) (Pr.1337)							
n+15	User Defined Cyclic Communication Output 8 (upper bytes) (Pr.1337)							
n+16	User Defined Cyclic Communication Output 9 (lower bytes) (Pr.1338)							
n+17	User Defined Cyclic Communication Output 9 (upper bytes) (Pr.1338)							
n+18	User Defined Cyclic Communication Output 10 (lower bytes) (Pr.1339)							
n+19	User Defined Cyclic Communication Output 10 (upper bytes) (Pr.1339)							
n+20	User Defined Cyclic Communication Output 11 (lower bytes) (Pr.1340)							
n+21	User Defined Cyclic Communication Output 11 (upper bytes) (Pr.1340)							
n+22	User Defined Cyclic Communication Output 12 (lower bytes) (Pr.1341)							
n+23	User Defined Cyclic Communication Output 12 (upper bytes) (Pr.1341)							
n+24	User Defined Cyclic Communication Output 13 (lower bytes) (Pr.1342)							
n+25	User Defined Cyclic Communication Output 13 (upper bytes) (Pr.1342)							
n+26	User Defined Cyclic Communication Output 14 (lower bytes) (Pr.1343)							
n+27	User Defined Cyclic Communication Output 14 (upper bytes) (Pr.1343)							

*1 "n" indicates the data length of the instance specified in **Pr.1319** (4 or 6 bytes).

In Pr.1394 to Pr.1398, specify the subindices to which the instance/index numbers are specified using Pr.1330 to Pr.1339.

Data No.	Instance/index specification	Sub index specification
1	Pr.1330	Pr.1394 (lower 8 bits)
2	Pr.1331	Pr.1394 (upper 8 bits)
3	Pr.1332	Pr.1395 (lower 8 bits)
4	Pr.1333	Pr.1395 (upper 8 bits)
5	Pr.1334	Pr.1396 (lower 8 bits)
6	Pr.1335	Pr.1396 (upper 8 bits)
7	Pr.1336	Pr.1397 (lower 8 bits)
8	Pr.1337	Pr.1397 (upper 8 bits)
9	Pr.1338	Pr.1398 (lower 8 bits)
10	Pr.1339	Pr.1398 (upper 8 bits)
11	Pr.1340	Fixed to "0"
12	Pr.1341	
13	Pr.1342	
14	Pr.1343	

- Data definitions, input assemblies

The following table indicates the mapping of the data in the producing instances of the Assembly Object. For details, refer to the Control Supervisor Object (29h) on page 156, and AC/DC Drive Object (2Ah) on page 157.

Name	Object		Instance No.	Attribute	
	Name	No.		Name	No.
Faulted	Control Supervisor	29h	1	Faulted	10
Warning	Control Supervisor	29h	1	Warning	11
Running1 (Fwd)	Control Supervisor	29h	1	Running1	7
Running2 (Rev)	Control Supervisor	29h	1	Running2	8
Ready	Control Supervisor	29h	1	Ready	9
Ctrl from net	Control Supervisor	29h	1	CtrlFromNet	15
Drive state	Control Supervisor	29h	1	State	6
Ref from net	AC/DC Drive	2Ah	1	RefFromNet	29
At reference	AC/DC Drive	2Ah	1	AtReference	3
Speed actual	AC/DC Drive	2Ah	1	SpeedActual	7
Torque actual	AC/DC Drive	2Ah	1	TorqueActual	11

◆ Connection Management Object (06h)

This object is used to manage the characteristics of a communication connection.

■ Service

Class	Instance
—	Forward_Open Forward_Close

◆ Motor Data Object (28h)

This object serves as a database for motor parameters.

■ Service

Class	Instance
Get_Attribute_Single	Get_Attribute_Single Set_Attribute_Single

■ Class attribute

No.	Name	Access	Type	Description
1	Revision	Get	UINT	0001h (Revision of the object)

■ Instance attribute

No.	Name	Access	Type	Description
3 ^{*1}	MotorType	Set/Get ^{*2}	USINT	3: PM synchronous motor 7: Squirrel cage induction motor
6 ^{*3}	Rated Current	Set/Get	UINT	Rated motor current (0.1 A increments) Instance 1: Pr.9 Instance 2: Pr.51
7 ^{*3}	Rated Voltage	Set/Get	UINT	Rated motor voltage (V) Instance 1: Pr.83 Instance 2: Pr.456
9 ^{*3}	RatedFreq	Set/Get	UINT	Rated motor frequency (Hz) Instance 1: Pr.84 Instance 2: Pr.457
12 ^{*3}	PoleCount	Set/Get	UINT	Number of motor poles Instance 1: Pr.81 Instance 2: Pr.454
15 ^{*3}	Rated Speed	Set/Get	UINT	Nominal speed (rpm) at rated frequency from nameplate ^{*4} Instance 1: Pr.84 × 120/ Pr.81 Instance 2: Pr.457 × 120/ Pr.454

*1 Instances 1 and 2 are supported.

*2 Writing is enabled only when the setting is the same as that of the inverter.

*3 When **Pr.77 Parameter write selection** ≠ "2", writing is restricted by the settings of Ethernet IP address for command source selection (**Pr.1449** to **Pr.1454**).

*4 When **Pr.81 (Pr.454)** = "9999", the formula is calculated with 4 poles.

◆ Control Supervisor Object (29h)

This object has the management functions for devices "Hierarchy of Motor Control Devices".

■ Service

Class	Instance
Get_Attribute_Single	Get_Attribute_Single Set_Attribute_Single Reset ^{*1} (operation command clear, output shutoff, protective function reset)

*1 Disabled during emergency drive operation.

Writing is restricted by the settings of Ethernet IP address for command source selection (**Pr.1449** to **Pr.1454**).

E.16 to E.20, E.PE6, E.PE2, E.CPU, E.SAF, E.CMB, E.1, E.5 to E.7, and E.13 are not reset. In this case, take an appropriate corrective action first, and reset them by power reset or inverter reset.

■ Class attribute

No.	Name	Access	Type	Description
1	Revision	Get	UINT	0001h (Revision of the object)

■ Instance 1 attributes

No.	Name	Access	Type	Description
3 ^{*1}	Run1 ^{*2}	Set/Get	BOOL	Forward rotation
4 ^{*1}	Run2 ^{*2}	Set/Get	BOOL	Reverse rotation
5 ^{*1}	NetCtrl	Set/Get	BOOL	Operation command source 0: Pr.338 = "1" 1: Pr.338 = "0" The actual status of the operation command source can be monitored with Attribute 15.
6	State	Get	USINT	0: Vendor Specific (Pr.502 = "2": communication fault detection enabled) 1: Startup (During inverter reset) 2: Not_Ready (Communication ready and RY signal-OFF) 3: Ready (Operation ready) 4: Enabled (During acceleration, constant-speed operation, or reverse rotation deceleration) 5: Stopping (During deceleration) 6: Fault_Stop (Deceleration by setting Pr.502 = "1") 7: Faulted (Fault)

No.	Name	Access	Type	Description
7	Running1	Get	BOOL	0: During stop or reverse rotation 1: Forward running
8	Running2	Get	BOOL	0: During stop or forward running 1: Reverse running
9	Ready	Get	BOOL	0: RY signal is OFF 1: RY signal is ON
10	Faulted	Get	BOOL	0: No fault 1: Fault
11	Warning	Get	BOOL	0: Without warnings 1: With warnings
12 ^{*1}	FaultRst	Set/Get	BOOL	0: No reset 0→1: Protective function reset ^{*3}
15	CtrlFrom Net	Get	BOOL	Operation command source monitoring 0: Local control 1: Network control

*1 Writing is restricted by the settings of Ethernet IP address for command source selection (Pr.1449 to Pr.1454).

*2 If both Run1 and Run2 are turned ON, the start signal is not changed. (The previous status remains unchanged.) If both Run1 and Run2 are turned ON in the Assembly Object (04h), the direction of rotation is not changed. That is because the start signal is not changed by giving a speed command to reverse the direction.

*3 E.16 to E.20, E.PE6, E.PE2, E.CPU, E.SAF, E.CMB, E.1, E.5 to E.7, and E.13 are not reset. In this case, take an appropriate corrective action first, and reset them by power reset or inverter reset.

◆ AC/DC Drive Object (2Ah)

This object models the functions specific to an AC or DC Drive, for example speed, torque, and position control.

■ Service

Class	Instance
Get_Attribute_Single	Get_Attribute_Single Set_Attribute_Single

■ Class attribute

No.	Name	Access	Type	Description
1	Revision	Get	UINT	0001h (Revision of the object)

■ Instance 1 attributes

No.	Name	Access	Type	Description
3	At Reference	Get	BOOL	During speed control 0: SU signal OFF 1: SU signal ON During torque control 0: The actual torque (monitor code: 07h) is out of the range of ±10% of the torque command value (monitor code: 20h). 1: The actual torque (monitor code: 07h) is within the range of ±10% of the torque command value (monitor code: 20h). During position control Fixed to "0"
4 ^{*2}	NetRef	Set/Get	BOOL	Speed/torque command source 0: Pr.339 = "1" 1: Pr.339 = "0 or 2" The actual status of the speed/torque command source can be monitored with Attribute 29.
6	DriveMode	Set/Get ^{*1}	USINT	0: Vendor specific mode 1: Speed control without encoder 2: Speed control with encoder 3: Torque control 5: Position control
7 ^{*3*4}	Speed Actual	Get	INT	Actual drive speed Unit: rpm / 2 ^{SpeedScale}
8 ^{*2*4*5}	SpeedRef	Set/Get	INT	Speed setting value Unit: rpm / 2 ^{SpeedScale}
9	Current Actual	Get	INT	Motor phase current Unit: 100 mA / 2 ^{CurrentScale}

No.	Name	Access	Type	Description
11 ^{*3}	Torque Actual	Get	INT	Actual torque Unit: N·m / 2 ^{TorqueScale}
12 ^{*2}	TorqueRef	Set/Get	INT	Torque command value (Pr.805) Unit: N·m / 2 ^{TorqueScale}
15	Power Actual	Get	INT	Output power Unit: W
17	Output Voltage	Get	INT	Output voltage Unit: V
18 ^{*2}	AccelTime	Set/Get	UINT	Acceleration time = Pr.7 (Pr.44) × Pr.18/Pr.20 Time from 0 to HighSpdLimit Unit: ms
19 ^{*2}	DecelTime	Set/Get	UINT	Deceleration time = Pr.8 (Pr.45) × Pr.18/Pr.20 Time from HighSpdLimit to 0 Unit: ms
20 ^{*2*4}	LowSpd Limit	Set/Get	UINT	Minimum speed limit (Pr.2) Unit: rpm / 2 ^{SpeedScale}
21 ^{*2*4}	HighSpd Limit	Set/Get	UINT	Maximum speed limit (Pr.18) Unit: rpm / 2 ^{SpeedScale}
22 ^{*2*6}	SpeedScale	Set/Get	SINT	Speed scaling factor Applied to attributes 7, 8, 20, and 21.
23 ^{*2*6}	Current Scale	Set/Get	SINT	Current scaling factor Applied to attribute 9.
24 ^{*2*6}	Torque Scale	Set/Get	SINT	Torque scaling factor Applied to attributes 11 and 12.
29	RefFromNet	Get	BOOL	Speed/torque command source monitoring 0: Local reference 1: Network reference

*1 Writing is enabled only when the setting is the same as that of the inverter.

*2 Writing is restricted by the settings of Ethernet IP address for command source selection (**Pr.1449 to Pr.1454**). However, the restriction is not applied to attributes 18, 19, 20, and 21 when **Pr.77 Parameter write selection** = "2".

*3 Use **Pr.290** to enable display of negative numbers during monitoring. For details, refer to the FR-E800 Instruction Manual (Function).

*4 Use the speed scale of Inverter Configuration Object (64h) to set a scaling factor. (Refer to [page 160](#).)

*5 When **Pr.541 Frequency command sign selection** = "1", the set frequency is a signed value. When the setting value is negative, the command is the inverse from the start command. (Refer to [page 149](#).)

*6 At power-ON or inverter reset, executing the reset service of the Identity Object (01h) resets the value to "0" (initial value).

NOTE

- When the data in attributes of AC/DC Drive Object (2Ah) is larger than the size of data type, the data is limited to the size of data size.

◆ Inverter Configuration Object (64h)

This object is used to read and write inverter parameters, monitor data, and inverter control parameters.

■ Service

Class	Instance
—	Get_Attribute_Single Set_Attribute_Single

■ Instance

No.	Name	Access	Type	Remarks
12288 to 16383 (3000h to 3FFFh)	Inverter Parameters ^{*1}	Set/Get	UINT	The inverter parameter number ^{*2} + 12288 (3000h) is the instance number.
16384 to 20479 (4000h to 4FFFh)	Monitor Data ^{*4*5}	Get	UINT	The monitor code ^{*3} + 16384 (4000h) is the index number.
20480 to 24575 (5000h to 5FFFh)	Inverter Control Parameters	Set/Get	UINT	Inverter control parameter

*1 When parameter write is performed, data are written to RAM for I/O message communication. Writing to EEPROM or RAM is selected according to the setting in **Pr.342 Communication EEPROM write selection** for explicit message communication.

*2 For the numbers and names of inverter parameters, refer to the parameter list of the Instruction Manual (Function).

*3 For details of the monitor codes and monitor items, refer to the description of **Pr.52** in the Instruction Manual (Function).

*4 Display of negative numbers during monitoring set in **Pr.290 Monitor negative output selection** is disabled.

*5 The display can be changed from the frequency to rotations per minute (machine speed) using **Pr.53**. When the machine speed is displayed, the value is incremented by one.

- Inverter control parameter

Instance No.	Name	Access	Remarks
20482 (5002h) ^{*1}	Inverter reset	Set/Get	Set 9966h for the written value. The read value is fixed to 0000h.
20483 (5003h) ^{*1}	Parameter clear	Set/Get	Set 965Ah for the written value. The read value is fixed to 0000h.
20484 (5004h) ^{*1}	All parameter clear	Set/Get	Set 99AAh for the written value. The read value is fixed to 0000h.
20486 (5006h) ^{*1}	Parameter clear ^{*2}	Set/Get	Set 5A96h for the written value. The read value is fixed to 0000h.
20487 (5007h) ^{*1}	All parameter clear ^{*2}	Set/Get	Set AA99h for the written value. The read value is fixed to 0000h.
20488 (5008h)	Inverter status / control input command (extended) ^{*3}	Set/Get	Refer to page 160 .
20489 (5009h)	Inverter status / control input command ^{*3}	Set/Get	Refer to page 160 .
20981 (51F5h)	Fault record 1	Set/Get	Being 2 bytes in length, the data is stored as "00○○h". Refer to the lowest 1 byte for the error code. (For details on error codes, refer to the list of fault displays in the Instruction Manual (Maintenance).) The fault history is batch-cleared by writing to 20981 (51F5h). Set any value as data.
20982 (51F6h)	Fault record 2	Get	
20983 (51F7h)	Fault record 3	Get	
20984 (51F8h)	Fault record 4	Get	
20985 (51F9h)	Fault record 5	Get	
20986 (51FAh)	Fault record 6	Get	
20987 (51FBh)	Fault record 7	Get	
20988 (51FCh)	Fault record 8	Get	
20989 (51FDh)	Fault record 9	Get	
20990 (51FEh)	Fault record 10	Get	
20992 (5200h) ^{*4}	Safety input status	Get	Refer to page 160 .
21216 (52E0h) ^{*1}	Speed scale (numerator)	Set/Get	Refer to page 160 .
21217 (52E1h) ^{*1}	Speed scale (denominator)	Set/Get	Refer to page 160 .

*1 Not available for I/O message communication.

*2 Settings in the communication parameters are not cleared.

*3 The data is written as a control input command for writing.
The data is read as the inverter status for reading.

*4 Parameter setting is available for the Ethernet model only. Access to the parameter using explicit message communication is allowed for the safety communication model and the IP67 model, but the function is disabled.

- Inverter status / control input command, and inverter status / control input command (extended)

Inverter status / control input command		
Bit	Definition	
	Control input command	Inverter status
0	—	RUN (Inverter running) ^{*2}
1	—	During forward rotation
2	—	During reverse rotation
3	RH (High-speed operation command) ^{*1}	Up to frequency
4	RM (Middle-speed operation command) ^{*1}	Overload alarm
5	RL (Low-speed operation command) ^{*1}	0
6	JOG operation selection 2	FU (Output frequency detection) ^{*2}
7	Second function selection	ABC (Fault) ^{*2}
8	Terminal 4 input selection	ABC2 (0) ^{*2}
9	—	Safety monitor output 2
10	MRS (Output stop) ^{*1}	0
11	—	0
12	RES (—) ^{*1}	0
13	—	0
14	—	0
15	—	Fault occurrence

Inverter status / control input command (extended)		
Bit	Definition	
	Control input command	Inverter status
0	NET X1 (—) ^{*1}	NET Y1 (0) ^{*2}
1	NET X2 (—) ^{*1}	NET Y2 (0) ^{*2}
2	NET X3 (—) ^{*1}	NET Y3 (0) ^{*2}
3	NET X4 (—) ^{*1}	NET Y4 (0) ^{*2}
4	NET X5 (—) ^{*1}	0
5	—	0
6	—	0
7	—	0
8	—	0
9	—	0
10	—	0
11	—	0
12	—	0
13	—	0
14	—	0
15	—	0

*1 The signal within parentheses () is assigned in the initial status. The function changes depending on the setting of **Pr.180 to Pr.189 (Input terminal function selection)**.

For details, refer to the description of **Pr.180 to Pr.189 (Input terminal function selection)** in the Instruction Manual (Function).

The signals assigned to the input terminals may be valid or invalid in the NET operation mode. (Refer to the Instruction Manual (Function).)

*2 The signal within parentheses () is assigned in the initial status. The function changes depending on the setting of **Pr.190 to Pr.197 (Output terminal function selection)**.

For details, refer to the description of **Pr.190 to Pr.197 (Output terminal function selection)** in the Instruction Manual (Function).

- Safety input status

Bit	Definition
0	0: Terminal S1 ON 1: Terminal S1 OFF (output shutoff)
1	0: Terminal S2 ON 1: Terminal S2 OFF (output shutoff)
2 to 15	0

- Speed scale

A scaling factor can be set for attributes 7, 8, 20, and 21 of AC/DC Drive Object (2Ah). (Refer to [page 157](#).)

Instance No.	Name	Access	Initial value	Setting range
21216 (52E0h) ^{*1}	Speed scale (numerator)	Set/Get	1	1 to 65535
21217 (52E1h) ^{*1}	Speed scale (denominator)	Set/Get	1	1 to 65535

*1 The setting value is applied immediately. At power-ON or inverter reset, executing the reset service of the Identity Object (01h) resets the value to the initial value.

Relationship between the set speeds of the master and the inverter

Set speed (inverter) = Set speed to be scaled (master) × (Speed scale (numerator) / Speed scale (denominator))

■ Instance attribute

No.	Name	Access	Type	Description
100 ^{*1}	Data	Set/Get	UINT	Inverter parameters, monitor data, and inverter control parameters.

No.	Name	Access	Type	Description
101 ^{*1}	Sub Data	Set/Get	UINT	Analog value (%) set in C3 (Pr.902) , C4 (Pr.903) , C6 (Pr.904) , C7 (Pr.905) , C39 (Pr.932) , C41 (Pr.933) , C43 (Pr.934) , and C45 (Pr.935) Example) C3 (Pr.902) : Instance = 902 + 12288 = 13190 (3386h), Attribute = 101

*1 When **Pr.77 Parameter write selection** ≠ "2", writing is restricted by the settings of Ethernet IP address for command source selection (**Pr.1449** to **Pr.1454**).

- Calibration parameter

Instance No.	Attribute	Name	Description
13188 (3384h)	100	Data	C0 (Pr.900)
	101	Sub Data	—
13189 (3385h)	100	Data	C1 (Pr.901)
	101	Sub Data	—
13190 (3386h)	100	Data	C2 (Pr.902)
	101	Sub Data	C3 (Pr.902)
13191 (3387h)	100	Data	125 (Pr.903)
	101	Sub Data	C4 (Pr.903)
13192 (3388h)	100	Data	C5 (Pr.904)
	101	Sub Data	C6 (Pr.904)
13193 (3389h)	100	Data	126 (Pr.905)
	101	Sub Data	C7 (Pr.905)
13205 (3395h) ^{*1}	100	Data	C12 (Pr.917)
	101	Sub Data	C13 (Pr.917)
13206 (3396h) ^{*1}	100	Data	C14 (Pr.918)
	101	Sub Data	C15 (Pr.918)
13207 (3397h) ^{*1}	100	Data	C16 (Pr.919)
	101	Sub Data	C17 (Pr.919)
13208 (3398h) ^{*1}	100	Data	C18 (Pr.920)
	101	Sub Data	C19 (Pr.920)
13220 (33A4h)	100	Data	C38 (Pr.932)
	101	Sub Data	C39 (Pr.932)
13221 (33A5h)	100	Data	C40 (Pr.933)
	101	Sub Data	C41 (Pr.933)
13222 (33A6h)	100	Data	C42 (Pr.934)
	101	Sub Data	C43 (Pr.934)
13223 (33A7h)	100	Data	C44 (Pr.935)
	101	Sub Data	C45 (Pr.935)

*1 Available only when the FR-E8AXY is installed.

NOTE

- Set 65520 (FFF0h) as a parameter value "8888" and 65535 (FFFFh) as "9999".
- To specify subindices in **Pr.1389** to **Pr.1398**, set "0" in attribute 100 and set "1" in attribute 101.

◆ TCP/IP Interface Object (F5h)

The object groups TCP/IP-related settings.

■ Service

Class	Instance
Get_Attribute_Single	Get_Attribute_All Get_Attribute_Single Set_Attribute_Single

■ Class attribute

No.	Name	Access	Type	Description
1	Revision	Get	UINT	0004h (Revision of the object)

■ Instance 1 attributes

No.	Name	Access	Type	Description
1	Status	Get	DWORD	Refer to "Status (Attribute 1)" on page 162 .
2	Configuration Capability	Get	DWORD	80 (0050h): Refer to "Configuration Capability (Attribute 2)" on page 162 .
3	Configuration Control	Set/Get	DWORD	Refer to "Configuration Control (Attribute 3)" on page 162 .
4	Physical Link Object	Get	Structure	Path size and Path
	Path size		UINT	0002h
	Path		Padded EPATH	20 F6 24 03h
5	Interface Configuration	Set/Get	Structure	TCP/IP interface setting
	IP Address		UDINT	IP address (Pr.1434 to Pr.1437)
	Network Mask		UDINT	Subnet mask (Pr.1438 to Pr.1441)
	Gateway Address		UDINT	Default gateway (Pr.442 to Pr.445)
	Name Server		UDINT	Fixed to 0
	Name Server 2		UDINT	Fixed to 0
	Domain Name		STRING	Fixed to 0
6	Host Name	Set/Get	STRING	Host name
13	Encapsulation Inactivity Timeout	Set/Get	UINT	0: Inactive 1 to 3600 s: TCP connection timeout after the message is received (Initial value: 120 s)

- Status (Attribute 1)

Bit	Name	Description
0 to 3	Interface Configuration Status	How to configure Attribute 5 0: Not configured 1: Configured by setting parameters, BOOTP, DHCP 2: Configured by hardware setting
4	—	Fixed to 0
5	Interface Configuration Pending	Attribute 5, setting change during pending. "1" is set when inverter reset is required to enable the setting change.
6 to 31	—	Fixed to 0

- Configuration Capability (Attribute 2)

Bit	Name	Description
0	BOOTP Client	0: Not supported 1: Supported
1	DNS Client	0: Not supported 1: Supported
2	DHCP Client	0: Not supported 1: Supported
3	DHCP-DNS Update	Fixed to 0
4	Configuration Settable	Attribute 5, access condition 0: Setting not allowed 1: Setting allowed
5	Hardware Configurable	Attribute 5, hardware configuration condition 0: Setting not allowed 1: Setting allowed
6	Interface Configuration Change Requires Reset	Attribute 5, change application condition 0: Immediately 1: After reset
7	AcdCapable	0: Not supported 1: Supported
8 to 31	—	Fixed to 0

- Configuration Control (Attribute 3)

Bit	Name	Description
0 to 3	Configuration Method	Network setting acquisition method after startup of the inverter 0: Parameter setting 1: BOOTP 2: DHCP
4 to 31	—	Fixed to 0

◆ Ethernet Link Object (F6h)

This object groups diagnostic information for the Ethernet interface.

■ Service

Class	Instance
Get_Attribute_All Get_Attribute_Single	Get_Attribute_All Get_Attribute_Single Set_Attribute_Single

■ Class attribute

No.	Name	Access	Type	Description
1	Revision	Get	UINT	0004h (Revision of the object)
2	Max Instance	Get	UINT	(Highest instance number)
3	Number of instances	Get	UINT	(Number of instances)

■ Instance attribute

No.	Name	Access	Type	Description
1 ^{*1}	Interface Speed	Get	UDINT	10 or 100: Actual Ethernet interface speed (Mbps)
2 ^{*1}	Interface Flags	Get	DWORD	Refer to "Interface Flags (Attribute 2)" on page 163 .
3 ^{*1}	Physical Address	Get	Array of 6 USINT	(MAC ID): Assigned MAC address
6 ^{*1,2}	Interface Control	Set/Get	Structure	Control Bits and Forced Interface Speed
	Control Bits		WORD	Refer to "Control Bits (Attribute 6)" on page 164 .
	Forced Interface Speed		UINT	0, 10, or 100: Speed at which the interface shall be forced to operate. Returns 'Object state Conflict' if auto-negotiation is enabled.
7	Interface Type	Get	USINT	Instance 1, 2: 2 (Twisted pair cable) Instance 3: 1 (Embedded interface)
10	Interface Label	Get	SHORT_ STRING	Instance 1: Port 1 Instance 2: Port 2 Instance 3: Internal
11 ^{*1}	Interface Capability	Get	Structure	Capability Bits and Speed/Duplex Options
	Capability Bits		DWORD	11 (000Bh): Refer to "Capability Bits (Attribute 11)" on page 164 .
	Speed/Duplex Options		Structure	—
			USINT	4: Number of arrays
			Structure array	—
			UINT	10 or 100: Ethernet interface speed (Mbps)
	USINT	0: Half duplex 1: Full duplex		

*1 Instances 1, 2, and 3 are supported.

*2 When **Pr.77 Parameter write selection** ≠ "2", writing is restricted by the settings of Ethernet IP address for command source selection (**Pr.1449 to Pr.1454**).

• Interface Flags (Attribute 2)

Bit	Name	Description
0	Link status	IEEE 802.3 communication interface link status 0: Inactive 1: Active
1	Half/full duplex	Current duplex mode 0: Half duplex 1: Full duplex
2 to 4	Negotiation Status	Link auto-negotiation status 0 to 2: Disabled. 3: Successfully negotiated speed and duplex. 4: Auto-negotiation not attempted. Forced speed and duplex.
5	Manual Setting requires Reset	0: Immediately 1: After reset
6 to 31	—	Fixed to 0

- Control Bits (Attribute 6)

Bit	Name	Description
0	Auto-negotiate	0: Inactive 1: Active
1	Forced Duplex Mode	Duplex mode when Auto-negotiate (Bit 0) = 0 0: Half duplex 1: Full duplex
2 to 15	—	Fixed to 0

- Capability Bits (Attribute 11)

Bit	Name	Description
0	Manual Setting Requires Reset	Attribute 6, change application condition 0: Immediately (Instance 3) 1: After reset (Instance 1, 2)
1	Auto-negotiate	0: Not supported (Instance 3) 1: Not supported (Instance 1, 2)
2	Auto-MDIX	Fixed to 0 (not supported)
3	Manual Speed/Duplex	Fixed to 1 (supported)
4 to 31	—	Fixed to 0

◆ CiA402 drive profile

Index	Sub index	Name	Description	Access	Type
24639 (603Fh)	00h	Error code	Error number The error code of the latest fault that occurred after power-ON or an inverter reset is returned. When no fault occurs, no error is returned. When the fault history is cleared during occurrence of a fault, no error is returned. The upper eight bits are fixed to FF, and the lower eight bits represent the error code. (FFXXh: "XX" represents the error code.) (For details on error codes, refer to the list of fault displays in the Instruction Manual (Maintenance).)	Get	Unsigned16
24643 (6043h)	00h	vl velocity demand	Output frequency (r/min)*1 The output frequency is read in r/min. Monitoring range: -32768 (8000h) to 32767 (7FFFh) When Pr.81 = "9999", the number of motor poles is regarded as 4.	Get	Integer16
24644 (6044h)	00h	vl velocity actual value	Operation speed (r/min)*1 The operation speed is read in r/min. Monitoring range: -32768 (8000h) to 32767 (7FFFh) When Pr.81 = "9999", the number of motor poles is regarded as 4.	Get	Integer16
24672 (6060h)	00h	Modes of operation	Control mode: -1 (vendor specific operation mode) (fixed)	Set/Get	Integer8
24673 (6061h)	00h	Modes of operation display	Current control mode: -1 (vendor specific operation mode) (fixed)	Get	Integer8
24674 (6062h)	00h	Position demand value	Position command (pulse) The position command before the electronic gear operation is read.	Get	Integer32
24675 (6063h)	00h	Position actual internal value	Current position (pulse) The current position after the electronic gear operation is read.	Get	Integer32
24676 (6064h)	00h	Position actual value	Current position (pulse) The current position before the electronic gear operation is read.	Get	Integer32
24689 (6071h)	Function disabled				
24692 (6074h)	00h	Torque demand	Torque demand value (%) The torque command is read.	Get	Integer16
24695 (6077h)	00h	Torque actual value	Torque actual value (%) The motor torque is read.	Get	Integer16
24698 (607Ah)	00h	Target position	Target position (pulse) Set the target position in the direct command mode. Initial value: 0 Setting range: -2147483647 to 2147483647 (For the direct command mode, refer to the FR-E800 Instruction Manual (Function).)	Set/Get	Integer32
24703 (607Fh)	00h	Max profile velocity	Maximum profile speed (r/min) Set Pr.18 High speed maximum frequency in r/min. Setting range: 0 to 590 Hz	Set/Get	Unsigned32
24705 (6081h)	00h	Profile velocity	Profile speed (r/min) Set the maximum speed in the direct command mode. Initial value: 0 Setting range: 0 to (120 × 590 Hz / Pr.81) (For the direct command mode, refer to the FR-E800 Instruction Manual (Function).)	Set/Get	Unsigned32
24707 (6083h)	00h	Profile acceleration	Acceleration time constant (ms) <Position control> Set the acceleration time in the direct command mode. Initial value: 5000 Setting range: 10 to 360000 The last digit is rounded off. (For example, 1358 ms becomes 1350 ms.) (For the direct command mode, refer to the FR-E800 Instruction Manual (Function).) <Other than position control> Set Pr.7 Acceleration time in ms. Setting range: 0 to 3600 s The last two digits are rounded off when Pr.21 Acceleration/ deceleration time increments = "0", and the last digit is rounded off when Pr.21 = "1".	Set/Get	Unsigned32

Index	Sub index	Name	Description	Access	Type
24708 (6084h)	00h	Profile deceleration	Deceleration time constant (ms) <Position control> Set the deceleration time in the direct command mode. Initial value: 5000 Setting range: 10 to 360000 The last digit is rounded off. (For example, 1358 ms becomes 1350 ms.) (For the direct command mode, refer to the FR-E800 Instruction Manual (Function).) <Other than position control> Set Pr.8 Deceleration time in ms. Setting range: 0 to 3600 s The last two digits are rounded off when Pr.21 Acceleration/ deceleration time increments = "0", and the last digit is rounded off when Pr.21 = "1".	Set/Get	Unsigned32
24719 (608Fh)	—	Position encoder resolution	Encoder resolution (machine side / motor side)	—	—
	00h	Highest sub-index supported	Maximum value of subindex: 02h (fixed)	Get	Unsigned8
	01h	Encoder increments	Encoder resolution Set Pr.369 Number of encoder pulses . Setting range: 2 to 4096	Set/Get	Unsigned32
	02h	Motor revolutions	Motor speed (rev): 00000001h (fixed)	Set/Get	Unsigned32
24721 (6091h)	—	Gear ratio	Gear ratio	—	—
	00h	Highest sub-index supported	Maximum value of subindex: 02h (fixed)	Get	Unsigned8
	01h	Motor revolutions	Motor shaft revolutions ^{*2} Set Pr.420 Command pulse scaling factor numerator (electronic gear numerator) . Setting range: 1 to 32767	Set/Get	Unsigned32
	02h	Shaft revolutions	Drive shaft revolutions ^{*2} Set Pr.421 Command pulse multiplication denominator (electronic gear denominator) . Setting range: 1 to 32767	Set/Get	Unsigned32
24728 (6098h)	00h	Homing method	Home position return method Set the home position return method in the direct command mode. ^{*3} (For the direct command mode and the home position return method, refer to the FR-E800 Instruction Manual (Function).)	Set/Get	Integer8
24729 (6099h)	—	Homing speeds	Home position return speed	—	—
	00h	Highest sub-index supported	Maximum value of subindex: 01h (fixed)	Get	Unsigned8
	01h	Speed during search for switch	Motor speed during home position returning (r/min) Set the home position return speed in the direct command mode. Initial value: 120 × 2 Hz / Pr.81 Setting range: 0 to (120 × 400 Hz / Pr.81) (For the direct command mode, refer to the FR-E800 Instruction Manual (Function).)	Set/Get	Unsigned32
24730 (609Ah)	00h	Homing acceleration	Home position return acceleration/deceleration time (ms) Set the home position return acceleration/deceleration time in the direct command mode. Initial value: 5000 Setting range: 10 to 360000 The last digit is rounded off. (For example, 1358 ms becomes 1350 ms.) (For the direct command mode, refer to the FR-E800 Instruction Manual (Function).)	Set/Get	Unsigned32
24820 (60F4h)	00h	Following error actual value	Droop pulse (pulse) The droop pulse before the electronic gear operation is read.	Get	Integer32
24826 (60FAh)	00h	Control effort	Speed command after position loop ^{*1} The ideal speed command is read.	Get	Integer32
24828 (60FCh)	00h	Position demand internal value	Position command (pulse) The position command after the electronic gear operation is read.	Get	Integer32
25858 (6502h)	00h	Supported drive modes	Supported control mode: 00010000h (vendor specific operation mode)	Get	Unsigned32

- *1 The value is displayed and set in r/min regardless of the settings in **Pr.53**.
The frequency is converted to the rotation speed for reading, and the setting value is converted to the frequency for writing.
- *2 When parameter write is performed, data are written to RAM for I/O message communication. Writing to EEPROM or RAM is selected according to the setting in **Pr.342 Communication EEPROM write selection** for explicit message communication.
- *3 The following table shows home position return methods corresponding to the Index 6098h setting values.

6098h setting	Home position return method
-3	Data set type
-4	Stopper type (home position return direction: position pulse increasing direction)
-5 (initial value)	Ignoring the home position (servo ON position as the home position)
-7	Count type with front end reference (home position return direction: position pulse increasing direction)
-36	Stopper type (home position return direction: position pulse decreasing direction)
-39	Count type with front end reference (home position return direction: position pulse decreasing direction)
-65	Stopper type (home position return direction: start command direction)
-66	Count type with front end reference (home position return direction: start command direction)

NOTE

- The command interface in the Network operation mode is determined by the **Pr.550 NET mode operation command source selection** setting. (Refer to the FR-E800 Instruction Manual (Function).)
- When the data is read, the value is displayed with a sign regardless of the **Pr.290 Monitor negative output selection** setting.

◆ Data format

■ Explicit Message communication (request format)

	Byte No.	Field	Remarks
Common Industrial Protocol	0	Service	Service code
	1	Request Path Size	Data size of Request Path
	2 to n	Request Path	Application path
	n+1 to m	Data	Service specific data

■ Explicit Message communication (response format)

	Byte No.	Field	Remarks
Common Industrial Protocol	0	Reply Service	Request service code +80h
	1	Reserved	Fixed to "0"
	2	General Status	General status code
	3	Size of Additional Status	Data size of Additional Status
	4	Additional Status	Not extended when the value is "0".
	5		
6 to n	Response Data		

■ I/O Message communication (master to inverter)

	Byte No.	Field	Remarks
Common Industrial Protocol	0	CIP Sequence Count	Sequence No.
	1		
	2 to 5	32bit Header	Connection mode
	6 to n	Data	

■ I/O Message communication (inverter to master)

	Byte No.	Field	Remarks
Common Industrial Protocol	0	CIP Sequence Count	Sequence No.
	1		
	2 to n	Data	

◆ Error number

The error information for request command is stored in General Status of the response format for the Explicit Message communication.

Error No.	Name	Description
00h	Success	The service was successfully executed by the specified object.
05h	Path destination unknown	The path is unknown or references an object class, instance, or structure element not included in the processing node.
09h	Invalid attribute value	Invalid attribute data was detected.
10h	Device state conflict	The requested service cannot be executed in the current mode/state of the device.
20h	Invalid parameter	A parameter assigned to the request was invalid.

◆ Programming examples

The following explains the programming examples for controlling the inverter with sequence programs. Check that "44818" (EtherNet/IP) is set in any of **Pr.1427 to Pr.1430** (Ethernet function selection).

■ Programming example for forward rotation operation at 1500 r/min

- Connection settings in the engineering software

Select "Extended Speed Control" for the "Connections" setting of the inverter.

Names of setting items may differ depending of the engineering software used.

- Network setting and device examples

Data in D101 to D102 reflect the data for cyclic communication with inverters, either by data transmission to the buffer memory or using function blocks, according to the specification of the master module.

Device name	Description
M0	Forward rotation start
D100.0	Class1_Get_Set_Request
D101	Extended Speed Control Output_0
D101.0	Run fwd
D101.1	Run rev
D101.2	Fault reset
D101.3	—
D101.4	—
D101.5	NetCtrl
D101.6	NetRef
D101.7 to D101.F	—
D102	Speed reference
D103	Extended Speed Control Input_0
D103.0	Faulted
D103.1	Warning
D103.2	Running 1(Fwd)
D103.3	Running 2(Rev)
D103.4	Ready
D103.5	Ctrl from net
D103.6	Ref from net
D103.7	At reference
D103.8 to D103.F	—
D104	Speed actual

Turning ON D100.0 (Class1_Get_Set_Request) turns ON D101.5 (NetCtrl) and D101.6 (NetRef), enabling the control by the master via network.

- Rotation speed setting: Speed reference = 1500 r/min

Turning ON M0 (Forward rotation start) turns ON D101.0 (Run fwd) to start forward rotation operation at 1500 r/min.

Turning OFF M0 stops operation.

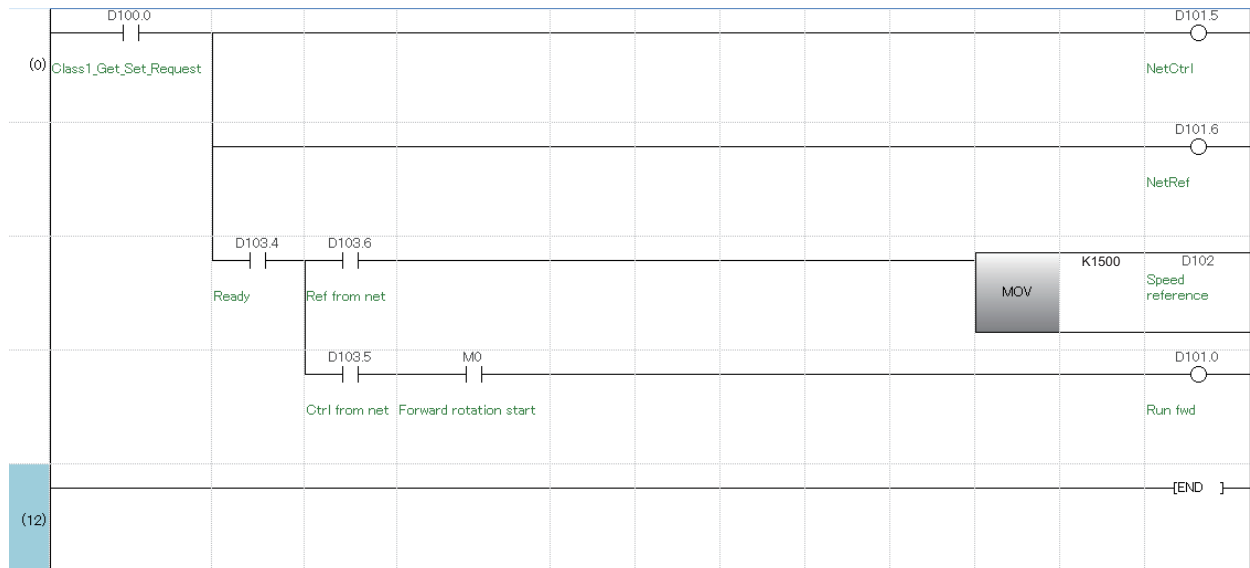

◆ Setting example

- The following tables show example settings when user defined cyclic communication data are selected (Assembly Object (04h)). Data are written to the inverter when I/O communications are in run state and the data are updated by the master. (The response time to write the data is 100 ms at the most.)

- Instance 100 (64h): Configurable Output

Byte	Bit 7	Bit 6	Bit 5	Bit 4	Bit 3	Bit 2	Bit 1	Bit 0
0	0	NetRef	NetCtrl	0	0	Fault reset	Run rev	Run fwd
1	00h							
2	Speed reference (Low byte)							
3	Speed reference (High byte)							
4	User Defined Cyclic Communication Input 1 (lower bytes) (Pr.1320)							
5	User Defined Cyclic Communication Input 1 (upper bytes) (Pr.1320)							
6	User Defined Cyclic Communication Input 2 (lower bytes) (Pr.1321)							
7	User Defined Cyclic Communication Input 2 (upper bytes) (Pr.1321)							

- Instance 150 (96h): Configurable Input

Byte	Bit 7	Bit 6	Bit 5	Bit 4	Bit 3	Bit 2	Bit 1	Bit 0
0	At reference	Ref from net	Ctrl from net	Ready	Running 2 (Rev)	Running1 (Fwd)	Warning	Faulted
1	Drive state							
2	Speed actual (Low byte)							
3	Speed actual (High byte)							
4	User Defined Cyclic Communication Output 1 (lower bytes) (Pr.1330)							
5	User Defined Cyclic Communication Output 1 (upper bytes) (Pr.1330)							
6	User Defined Cyclic Communication Output 2 (lower bytes) (Pr.1331)							
7	User Defined Cyclic Communication Output 2 (upper bytes) (Pr.1331)							
8	User Defined Cyclic Communication Output 3 (lower bytes) (Pr.1332)							
9	User Defined Cyclic Communication Output 3 (upper bytes) (Pr.1332)							
10	User Defined Cyclic Communication Output 4 (lower bytes) (Pr.1333)							
11	User Defined Cyclic Communication Output 4 (upper bytes) (Pr.1333)							
12	User Defined Cyclic Communication Output 5 (lower bytes) (Pr.1334)							
13	User Defined Cyclic Communication Output 5 (upper bytes) (Pr.1334)							

- Parameters

Pr.	Name	Setting example	Remarks
1318	User Defined Cyclic Communication Input fixing format selection	21 (15h)	Extended Speed Control Output
1320	User Defined Cyclic Communication Input 1 Mapping	12295 (3007h)	P.7 Acceleration time 7 (0007h) + 12288 (3000h)
1321	User Defined Cyclic Communication Input 2 Mapping	12296 (3008h)	Pr.8 Deceleration time 8 (0008h) + 12288 (3000h)
1319	User Defined Cyclic Communication Output fixing format selection	71 (47h)	Extended Speed Control Input
1330	User Defined Cyclic Communication Output 1 Mapping	12295 (3007h)	P.7 Acceleration time 7 (0007h) + 12288 (3000h)
1331	User Defined Cyclic Communication Output 2 Mapping	12296 (3008h)	Pr.8 Deceleration time 8 (0008h) + 12288 (3000h)
1332	User Defined Cyclic Communication Output 3 Mapping	16386 (4002h)	Monitored output current 2 (0002h) + 16384 (4000h)
1333	User Defined Cyclic Communication Output 4 Mapping	12543 (30FFh)	Pr.255 Life alarm status display 255 (00FFh) + 12288 (3000h)
1334	User Defined Cyclic Communication Output 5 Mapping	20981 (51F5h)	Fault record 1

- Connection settings in the engineering software

Set "Configurable" for the "Connections" setting of the inverter. Change the setting according to the data length set in instance 100/150. (When the settings are inconsistent, communication is not established.)

Change the "Input Size" setting to "14bytes".

Change the "Output Size" setting to "8bytes".

Names of setting items may differ depending of the engineering software used.

2.12 PROFINET

2.12.1 Outline



PROFINET is available for the FR-E800-(SC)EPB and FR-E806-SCEPB.

When the PROFINET communication operation is performed through the Ethernet connector on the inverter, data transmission is enabled for parameters, command data, and feedback data between a master and inverters.

Some functions are not supported depending on the date of manufacture of the inverter. For details of specification changes, refer to [page 290](#).

◆ Communication specifications

The communication specification varies depending on the specification of the master.

Item	Description
Category	100BASE-TX
Communication speed	100 Mbps (10 Mbps is not supported.)
Maximum number of branches	No upper limit on the same Ethernet network
Number of cascade connection stages	Maximum: 2
Connection cable	Ethernet cable (IEEE 802.3 100BASE-TX compliant cable and ANSI/TIA/EIA-568-B (Category 5e) compliant shielded 4-pair branched cable)
Topology	Line, star, or a combination of line and star
PROFINET communication specifications	PROFINET IO Device V2.35

◆ Wiring method

- When only one connector is used in star topology, use PORT 1.
- When two connectors are used in line topology, use PORT1 for connection with the master, and use PORT2 for connection with PORT1 of the adjacent inverter.

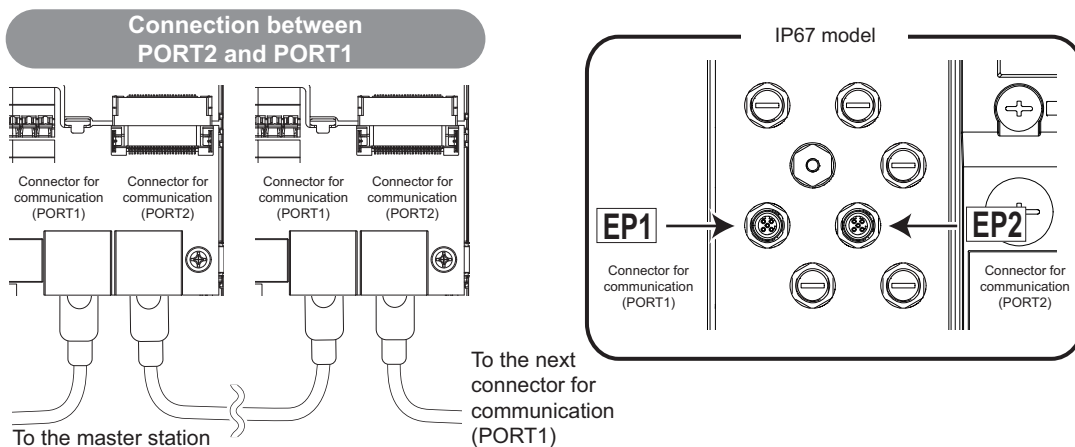

◆ Operation status LEDs

LED name	Description	LED status	Remarks
NS	Communication status	OFF	Power-OFF / during inverter reset
		Blinking green	No connections established with the master / Connections established with the master (The master is in the stop state.)
		Solid green	Connections established with the master (The master is in the run state.)
MS	Inverter status	OFF	Power-OFF / during inverter reset
		ON (green)	Operating properly
		Red	Fault detected
LINK1	Connector for communication (PORT1) status	OFF	Power-OFF/link-down
		Blinking green	Link-up (Data reception in progress)
		Solid green	Link-up
LINK2	Connector for communication (PORT2) status	OFF	Power-OFF/link-down
		Blinking green	Link-up (Data reception in progress)
		Solid green	Link-up

NOTE

- Depending on packets sent to the inverter while the master is in the stop state, the NS LED may not turn blinking green. The run/stop state is determined by IOCS of the packet sent from the master to the inverter (Good (80h): run, Bad (60h): stop). When the following master is used, the above-mentioned operation is performed in the stop state.

Manufacturer	Model	Version
SIEMENS	SIMATIC S7-1500	CPU: 1511F-1 PN Product number: 6ES7511-1FK02-0AB0 Firmware version: V 02.05.02

◆ GSDML file

A GSDML file is available for download.

Model	Classification	GSDML file
Ethernet model	PROFINET	GSDML-V2.35-MitsubishiElectric-FR-E800-E-[yyyymmdd].xml
Safety communication model IP67 model	PROFINET* ¹ PROFINET + PROFI-safe	GSDML-V2.35-MitsubishiElectric-FR-E800-SCE-[yyyymmdd].xml

([yyyymmdd]: revision date)

*1 The file with a revision date of 20221014 or later is compatible.

Mitsubishi Electric FA Global Website:

www.mitsubishielectric.com/fa/products/drv/inv/support/e800/network.html

The download is free at the website above. For details, contact your sales representative.

NOTE

- The GSDML file is used in engineering software. To install the GSDML file properly, refer to the instruction manual of the applicable engineering software.
- When only PROFINET is used for the safety communication model or the IP67 model, an error occurs if PROFI-safe Telegram is set. Delete the PROFI-safe Telegram setting, and set **Pr.S002 Safety communication function selection** to "0 (initial value)" (safety communication functions disabled).

2.12.2 PROFINET configuration

◆ Procedure

The procedure differs depending on the master device and the engineering software used. For details, refer to the Instruction Manual of the master device and the engineering software.

■ Before communication

1. Connect each unit with an Ethernet cable. (Refer to [page 15](#).)
2. Set "34962" (PROFINET) in any of **Pr.1427 to Pr.1430 Ethernet function selection 1 to 4**. (Refer to [page 173](#).)
(Example: **Pr.1429** = "45238" (CC-Link IE TSN) (initial value) → "34962" (PROFINET))
When **Pr.1429** = "45238 (initial value)" (CC-Link IE TSN), change the value to "34962" (PROFINET). When "45238" is set in any of **Pr.1427 to Pr.1430**, the priority is given to CC-Link IE TSN, disabling PROFINET.
3. Reset the inverter, or turn OFF and then ON the power.

■ Network configuration

1. Add the downloaded GSDML file to the engineering software.
2. Detect the inverters on the network using the engineering software.
3. Add the detected inverters to the network configuration settings.
4. Configure the module settings for the inverters.
Set the device name for each inverter when two or more inverters are connected.

■ Checking communication

The following table shows the status of the LEDs when communication is established between the programmable controller and the inverter.

NS	MS	LINK1	LINK2
Solid green	Solid green	Blinking green ^{*1}	

^{*1} The LED on either LINK1 or LINK2 will blink depending on the port (port 1 or 2) the Ethernet cable is connected to.

2.12.3 Initial setting for PROFINET

Use the following parameters to perform required settings for Ethernet communication between the inverter and other devices. To make communication between other devices and the inverter, perform the initial settings of the inverter parameters to match the communication specifications of the devices. Data communication cannot be made if the initial settings are not configured or if there is any setting error.

Pr.	Name	Initial value	Setting range	Description
1427 N630 ^{*1}	Ethernet function selection 1	5001	502, 5000 to 5002, 5006 to 5008, 5010 to 5013, 9999, 34962, 45237, 45238, 61450	Set the application, protocol, etc.
1428 N631 ^{*1}	Ethernet function selection 2	45237		
1429 N632 ^{*1}	Ethernet function selection 3	45238		
1430 N633 ^{*1}	Ethernet function selection 4	9999		
1426 N641 ^{*1}	Link speed and duplex mode selection	0	0 to 4	Set the communication speed and the communication mode (full-duplex/half-duplex).

^{*1} The setting is applied after an inverter reset or next power-ON.

NOTE

- For PROFINET, the IP filtering function (Ethernet) (**Pr.1442 to Pr.1448**) settings are invalid.

◆ Precautions for PROFINET communication

- For PROFINET, do not change initial values of **Pr.1449 to Pr.1454** used to specify the Ethernet IP address range for command source selection as the IP address is not used. Setting a value other than the initial value in any of the above parameters may cause an Ethernet communication fault (E.EHR). If the fault occurs, reset the setting of the relevant parameter to the initial value, or set "9999" in **Pr.1432 Ethernet communication check time interval**.
- When the device settings (IP address, subnet mask, and default gateway address settings) are inconsistent between the engineering tool and the connected inverter, "0" is set in **Pr.442 to Pr.445, Pr.1434 to Pr.1441** (EEPROM).

◆ Ethernet function selection (Pr.1427 to Pr.1430)

To select PROFINET for the application, set "34962" (PROFINET) in any of **Pr.1427 to Pr.1430 Ethernet function selection 1 to 4**. When **Pr.1429** = "45238 (initial value)" (CC-Link IE TSN), change the value to "34962" (PROFINET). When "45238" is set in any of **Pr.1427 to Pr.1430**, the priority is given to CC-Link IE TSN, disabling PROFINET.

NOTE

- Change the setting if selected communication protocols cannot be used together. (Refer to [page 7](#) and [page 226](#).)

◆ Communication speed and full-duplex/half-duplex selection (Pr.1426)

Use **Pr.1426 Link speed and duplex mode selection** to set the communication speed and the full-duplex or half-duplex system. If the operation is not performed properly in the initial setting (**Pr.1426** = "0"), set **Pr.1426** according to the specifications of the connected device.

Pr.1426 setting	Communication speed	Full-duplex/half-duplex system	Remarks
0 (initial value)	Automatic negotiation	Automatic negotiation	The communication speed and the communication mode (half-duplex/full-duplex) are automatically negotiated to ensure the optimum setting. To set automatic negotiation, auto negotiation setting is required also in the master station.
1	100 Mbps	Full duplex	—
2	100 Mbps	Half duplex	—
3	10 Mbps	Full duplex	The communication speed is fixed at 100 Mbps. Do not set 10 Mbps.
4	10 Mbps	Half duplex	

2.12.4 Parameters related to PROFINET

The following parameters are used for PROFINET communication. Set the parameters as required.

Pr.	Name	Initial value	Setting range	Description
1320 to 1329 N810 to N819 ^{*1}	User Defined Cyclic Communication Input 1 to 10 Mapping	9999	5, 100, 12288 to 13787, 20488, 20489, 24672, 24689, 24698, 24703, 24705, 24707, 24708, 24719, 24721, 24728 to 24730	Users can assign a function to Setpoint Telegram (master to inverter) of Telegram 102.
			9999	Function disabled
1330 to 1343 N850 to N863 ^{*1}	User Defined Cyclic Communication Output 1 to 14 Mapping	9999	6, 101, 12288 to 13787, 16384 to 16483, 20488, 20489, 20981 to 20990, 20992 ^{*2} , 24639, 24643, 24644, 24673 to 24676, 24692, 24695, 24820, 24826, 24828, 25858	Users can assign a function to Actual Value Telegram (inverter to master) of Telegram 102.
			9999	Function disabled
1389 ^{*1}	User Defined Cyclic Communication Input Sub 1 and 2 Mapping	0	0 to 2, 256 to 258, 512 to 514	Pr.1389 (lower 8 bits): Subindex to which the signal number is specified using Pr.1320 Pr.1389 (upper 8 bits): Subindex to which the signal number is specified using Pr.1321

Pr.	Name	Initial value	Setting range	Description
1390 ^{*1}	User Defined Cyclic Communication Input Sub 3 and 4 Mapping	0	0 to 2, 256 to 258, 512 to 514	Pr.1390 (lower 8 bits): Subindex to which the signal number is specified using Pr.1322 Pr.1390 (upper 8 bits): Subindex to which the signal number is specified using Pr.1323
1391 ^{*1}	User Defined Cyclic Communication Input Sub 5 and 6 Mapping	0	0 to 2, 256 to 258, 512 to 514	Pr.1391 (lower 8 bits): Subindex to which the signal number is specified using Pr.1324 Pr.1391 (upper 8 bits): Subindex to which the signal number is specified using Pr.1325
1392 ^{*1}	User Defined Cyclic Communication Input Sub 7 and 8 Mapping	0	0 to 2, 256 to 258, 512 to 514	Pr.1392 (lower 8 bits): Subindex to which the signal number is specified using Pr.1326 Pr.1392 (upper 8 bits): Subindex to which the signal number is specified using Pr.1327
1393 ^{*1}	User Defined Cyclic Communication Input Sub 9 and 10 Mapping	0	0 to 2, 256 to 258, 512 to 514	Pr.1393 (lower 8 bits): Subindex to which the signal number is specified using Pr.1328 Pr.1393 (upper 8 bits): Subindex to which the signal number is specified using Pr.1329
N830 to N839 ^{*1}	User Defined Cyclic Communication Input Sub 1 to 10 Mapping	0	0 to 2	Subindices to which the signal numbers are specified using Pr.1320 to Pr.1329
1394 ^{*1}	User Defined Cyclic Communication Output Sub 1 and 2 Mapping	0	0 to 2, 256 to 258, 512 to 514	Pr.1394 (lower 8 bits): Subindex to which the signal number is specified using Pr.1330 Pr.1394 (upper 8 bits): Subindex to which the signal number is specified using Pr.1331
1395 ^{*1}	User Defined Cyclic Communication Output Sub 3 and 4 Mapping	0	0 to 2, 256 to 258, 512 to 514	Pr.1395 (lower 8 bits): Subindex to which the signal number is specified using Pr.1332 Pr.1395 (upper 8 bits): Subindex to which the signal number is specified using Pr.1333
1396 ^{*1}	User Defined Cyclic Communication Output Sub 5 and 6 Mapping	0	0 to 2, 256 to 258, 512 to 514	Pr.1396 (lower 8 bits): Subindex to which the signal number is specified using Pr.1334 Pr.1396 (upper 8 bits): Subindex to which the signal number is specified using Pr.1335
1397 ^{*1}	User Defined Cyclic Communication Output Sub 7 and 8 Mapping	0	0 to 2, 256 to 258, 512 to 514	Pr.1397 (lower 8 bits): Subindex to which the signal number is specified using Pr.1336 Pr.1397 (upper 8 bits): Subindex to which the signal number is specified using Pr.1337
1398 ^{*1}	User Defined Cyclic Communication Output Sub 9 and 10 Mapping	0	0 to 2, 256 to 258, 512 to 514	Pr.1398 (lower 8 bits): Subindex to which the signal number is specified using Pr.1338 Pr.1398 (upper 8 bits): Subindex to which the signal number is specified using Pr.1339
N870 to N879 ^{*1}	User Defined Cyclic Communication Output Sub 1 to 10 Mapping	0	0 to 2	Subindices to which the signal numbers are specified using Pr.1330 to Pr.1339

*1 The setting is applied after an inverter reset or next power-ON.

*2 Available for the Ethernet model only.

2.12.5 Data Exchange

◆ Process Data (Cyclic Data Exchange)

Cyclic data transmission is enabled between the master and the inverter for the command data sent from the master and the feedback data sent from the inverter.

■ Telegram types

Select a telegram type according to the control mode. Users can select communication data using Telegram 102.

Telegram	Description	Size (words)
1	Standard Telegram 1 (Speed control)	2
100	Telegram 100 (Torque control)	3
102	Telegram 102 (Custom)	Setpoint Telegram: 21 Actual Value Telegram: 29

Which telegram type is used, can be read using PROFIdrive parameter P922

NOTE

- Only one telegram module can be used at a time.

■ Data mapping

- Standard Telegram 1

Type	IO Data number	Name	Abbreviation	Data length (bit)
Setpoint Telegram (master to inverter)	1	Control word 1	STW1	16
	2	Speed setpoint A	NSOLL_A	16
Actual Value Telegram (inverter to master)	1	Status word 1	ZSW1	16
	2	Speed actual value A	NIST_A	16

- Telegram 100

Type	IO Data number	Name	Abbreviation	Data length (bit)
Setpoint Telegram (master to inverter)	1	Control word 1	STW1	16
	2	Target torque	—	16
	3	Speed setpoint A	NSOLL_A	16
Actual Value Telegram (inverter to master)	1	Status word 1	ZSW1	16
	2	Actual torque	—	16
	3	Speed actual value A	NIST_A	16

- Telegram 102

Type	IO Data number	Name	Sub index specification	Data length (bit)	Remarks
Setpoint Telegram (master to inverter)	1	Control word 1 (STW1)	—	16	Fixed
	2	Pr.1320	Pr.1389 (lower 8 bits)	32	The following signal numbers are selectable. 5: Speed setpoint A (NSOLL_A) (Refer to page 178.) 100: Target torque (Refer to page 179.) 12288 to 13787: Inverter Parameters (Refer to page 185.) 20488, 20489: Inverter Control Parameters (Refer to page 186.) 24639, 24643, 24644, 24673 to 24676, 24692, 24695, 24820, 24826, 24828, 25858: CiA402 Drive Profile (Refer to page 188.) When the data length of the selected signal is 16 bits, only the setting value for the lower 16 bits is valid.
	3	Pr.1321	Pr.1389 (upper 8 bits)	32	
	4	Pr.1322	Pr.1390 (lower 8 bits)	32	
	5	Pr.1323	Pr.1390 (upper 8 bits)	32	
	6	Pr.1324	Pr.1391 (lower 8 bits)	32	
	7	Pr.1325	Pr.1391 (upper 8 bits)	32	
	8	Pr.1326	Pr.1392 (lower 8 bits)	32	
	9	Pr.1327	Pr.1392 (upper 8 bits)	32	
	10	Pr.1328	Pr.1393 (lower 8 bits)	32	
	11	Pr.1329	Pr.1393 (upper 8 bits)	32	

Type	IO Data number	Name	Sub index specification	Data length (bit)	Remarks
Actual Value Telegram (inverter to master)	1	Status word 1 (ZSW1)	—	16	Fixed
	2	Pr.1330	Pr.1394 (lower 8 bits)	32	The following signal numbers are selectable. 6: Speed actual value A (NIST_A) (Refer to page 178.) 101: Actual torque (Refer to page 179.) 12288 to 13787: Inverter Parameters (Refer to page 185.) 16384 to 16483: Monitor Data (Refer to page 186.) 20488, 20489, 20981 to 20990, 20992: Inverter Control Parameters (Refer to page 186.) 24672, 24689, 24698, 24703, 24705, 24707, 24708, 24719, 24721, 24728 to 24730: CiA402 Drive Profile (Refer to page 188.) 20992 is available for the Ethernet model only.
	3	Pr.1331	Pr.1394 (upper 8 bits)	32	
	4	Pr.1332	Pr.1395 (lower 8 bits)	32	
	5	Pr.1333	Pr.1395 (upper 8 bits)	32	
	6	Pr.1334	Pr.1396 (lower 8 bits)	32	
	7	Pr.1335	Pr.1396 (upper 8 bits)	32	
	8	Pr.1336	Pr.1397 (lower 8 bits)	32	
	9	Pr.1337	Pr.1397 (upper 8 bits)	32	
	10	Pr.1338	Pr.1398 (lower 8 bits)	32	
	11	Pr.1339	Pr.1398 (upper 8 bits)	32	
	12	Pr.1340	Fixed to "0"	32	
	13	Pr.1341		32	
	14	Pr.1342		32	
	15	Pr.1343		32	

NOTE

- If the same signal number is specified in two or more of Pr.1320 to Pr.1329, the number set in the parameter with the smallest parameter number is valid. The same number set in the other parameters is regarded as "9999".
- When a nonexistent signal number or "9999" is set in Pr.1320 to Pr.1329, the data is not written.
- When a nonexistent signal number or "9999" is set in Pr.1330 to Pr.1343, "0" is read.

- Control word 1 (STW1) details

Bit	Name	Inverter operation
0	ON/OFF	0: OFF 1: ON
1	No Coast Stop/Coast Stop	0: Output shutoff 1: Output shutoff release
2	No Quick Stop/Quick Stop	0: Emergency stop 1: Emergency stop release
3	Enable/Disable Operation	0: Disabled 1: Enabled
4	—	Not used (fixed to "0")
5	Acceleration/deceleration interruption ^{*1} Unfreeze/Freeze Ramp Generator	0: Acceleration/deceleration stopped 1: Acceleration/deceleration not stopped Valid during speed control. Invalid when the start command is OFF or during automatic restart after instantaneous power failure.
6	Enable/Disable Setpoint	0: NSOLL_A disabled (frequency setting / speed limit value = "0") 1: NSOLL_A enabled
7	Fault Acknowledge (0→1)	When 20 ms or more elapses after the bit is turned ON, the fault buffer is cleared (when the inverter is in a fault status, the protective function is reset). ^{*2}
8	—	Not used (fixed to "0")
9	—	Not used (fixed to "0")
10	Control By PLC/No Control By PLC	0: STW1 disabled 1: STW1 enabled

Bit	Name	Inverter operation
11	Target torque enabled (Device-specific)	0: Target torque disabled (torque command = "0") 1: Target torque enabled (torque command = target torque)
12	Start command direction selection (Device-specific)	0: Forward when NSOLL_A > 0, reverse when NSOLL_A < 0 1: Reverse when NSOLL_A > 0, forward when NSOLL_A < 0
13	Home position return/positioning operation start (Device-specific)	0: Start command OFF 1: Start command ON Enabled when both conditions are satisfied: During position control and in S4 state (page 180)
14, 15	—	Not used (fixed to "0")

*1 Specifications differ depending on the date of manufacture of the inverter.

Operation when acceleration/deceleration is interrupted	SERIAL
<ul style="list-style-type: none"> • Interruption by updating the set frequency • Enabled only during operation with speed commands given by NSOLL_A 	<input type="checkbox"/> 214 ○○○○○○ or earlier
<ul style="list-style-type: none"> • Set frequency unaffected • Enabled also during operation with speed commands not given by NSOLL_A 	<input type="checkbox"/> 215 ○○○○○○ or later

*2 E.16 to E.20, E.PE6, E.PE2, E.CPU, E.CMB, E.1, E.5 to E.7, and E.13 are not reset. In this case, take an appropriate corrective action first, and reset them by power reset or inverter reset.

• Status word 1 (ZSW1) details

Bit	Name	Inverter operation
0	Ready To Switch On/Not Ready To Switch On	0: During stop (Not Ready For Switching On) 1: During stop (Ready For Switching On)
1	Ready To Operate/Not Ready To Operate	0: During stop (Not Switched On) (not in standby condition) 1: During stop (Switched On) (in standby condition)
2	Operation Enabled (drive follows setpoint)/ Operation Disabled	0: During stop (Operation Disabled) 1: During operation (Operation Enabled)
3	Fault Present/No Fault	0: No fault 1: Fault state (fault code stored in Fault numbers (P947))
4	Coast Stop Not Activated/Coast Stop Activated (No OFF2/OFF2) (output shutoff)	0: During output shutoff 1: Output shutoff release
5	Quick Stop Not Activated/Quick Stop Activated (No OFF3/OFF3) (during emergency stop)	0: During emergency stop 1: Emergency stop release
6	Switching On Inhibited/Switching On Not Inhibited	0: During stop (initial state) (Switching On Not Inhibited) 1: During stop (initial state) (Switching On Inhibited)
7	Warning Present/No Warning	0: No warning or alarm 1: Warning or alarm state
8	—	Not used (fixed to "0")
9	Control Requested/No Control Requested	0: Operation commands not sent from the controller 1: Operation commands sent from the controller
10 to 15	—	Not used (fixed to "0")

• Speed setpoint A (NSOLL_A), Speed actual value A (NIST_A)

Setting the set frequency (speed limit value) and monitoring the output frequency are available. The set frequency and the output frequency are calculated with the following formula relative to the inverter maximum frequency setting (**Pr.1 or Pr.18**). Calculated values are rounded down according to the effective number of digits.

Set frequency (speed limit value) (Hz) = (NSOLL_A / 4000h) × inverter maximum frequency (**Pr.1 or Pr.18**)

Output frequency (Hz) = (NIST_A / 4000h) × inverter maximum frequency (**Pr.1 or Pr.18**)

Item	Description
Data type	N2
Range ^{*1*2}	-32768 (8000h) to 32767 (7FFFh) (-200% to 199.99%)
Reference	16384 (4000h) = inverter maximum frequency (Pr.1 or Pr.18)
Sign ^{*2}	Plus: forward rotation Minus: reverse rotation

*1 When the calculation result is larger than 590 Hz, the value is applied to the set frequency.

*2 Use **Pr.290** to enable display of negative numbers during monitoring. For details, refer to the FR-E800 Instruction Manual (Function).

 **NOTE**

- When the target torque is assigned to Telegram 100 or Telegram 102, use bit 12 of STW1 to select the start command direction. The input to NSOLL_A is treated as an absolute value.
- When the HMS PROFINET network option A8NPRT is installed in the FR-A800 or FR-F800 inverter, **Pr.3 Base frequency** is used as reference. In the network configuration that includes the above, consider the difference of the reference value.

2

- Target torque, Actual torque

The rated torque is regarded as 100%. Setting is available in 1% increments and monitoring is available in 0.1% increments.

Target torque is clamped at -400% and 400%. The value is set in **Pr.805** (1000% reference) (RAM).

The motor torque (monitor code: 07h) is read for Actual torque.

 **NOTE**

- To use the torque command in Telegram 102, select 100 (Target torque) instead of 13093 (**Pr.805**).

State transition diagram of the inverter

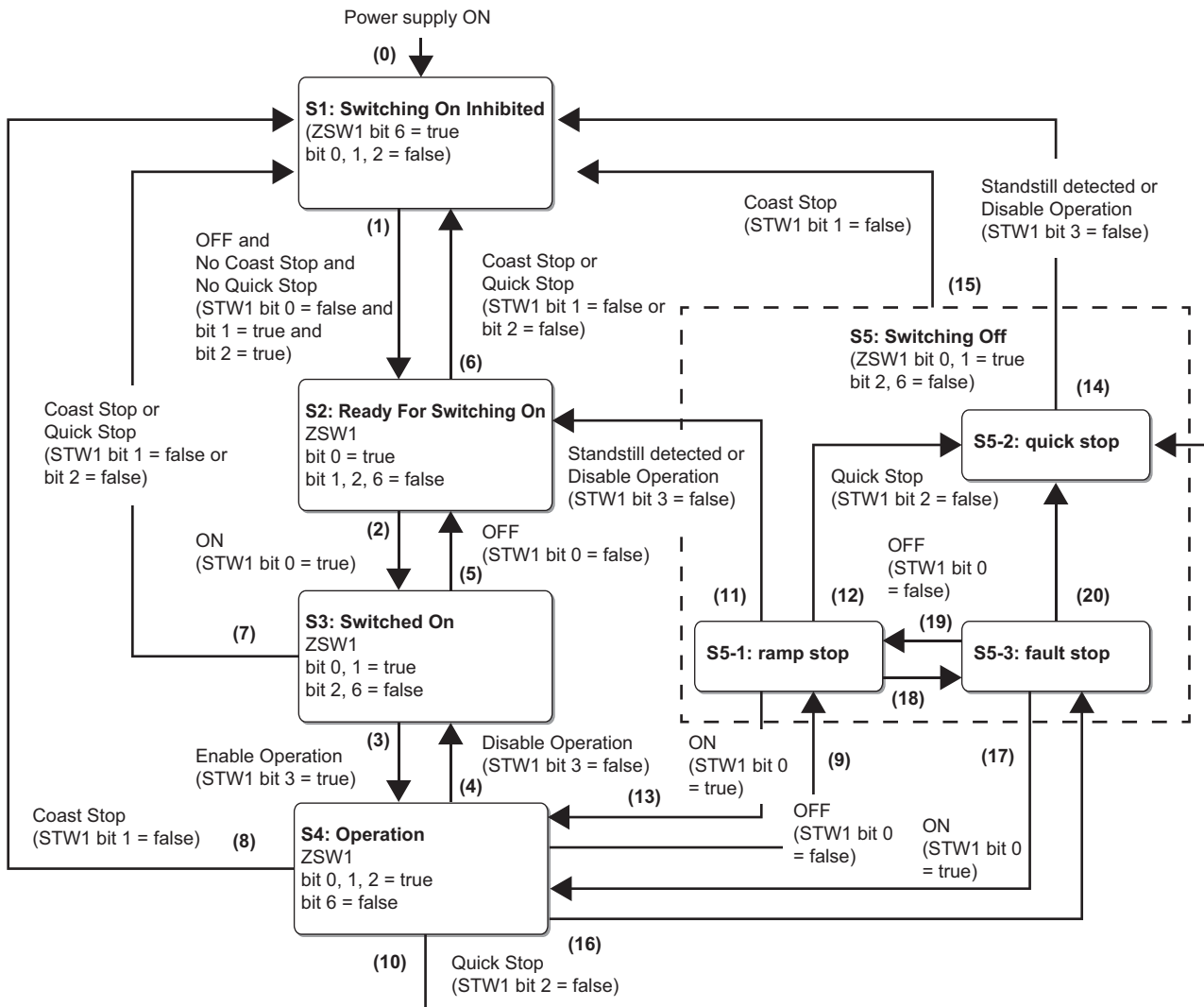

• Definition

Symbol	Name	Description	Inverter operation	
			Other than position control	Position control ^{*2}
S1 ^{*1}	Switching On Inhibited	During stop (initial status)	Output shutoff (RY signal OFF)	
S2	Ready For Switching On	During stop (ready)	Output shutoff (RY signal OFF)	
S3	Switched On	During stop (standby)	Output shutoff canceled (RY signal ON) ^{*3}	
S4 ^{*4}	Operation	During operation (enabled)	Start command ON (rotation direction depends on STW1 and NSOLL_A settings)	Servo-ON status
S5	Switching Off	Deceleration stop	—	
S5-1	ramp stop	Normal deceleration stop	Start command OFF, normal deceleration stop	Servo-OFF status Start command OFF, output shutoff
S5-2	quick stop	Emergency stop	Start command OFF, deceleration stop according to the Pr.1103 and Pr.815	Servo-OFF status Start command OFF, output shutoff
S5-3	fault stop	Deceleration stop due to a communication error	Deceleration stop due to a communication error (Pr.502 = "1 or 2")	

*1 The inverter state is forcefully changed to S1 when any of the following conditions is met:

- When an inverter fault occurs
- Mode other than Network operation mode
- During commercial power supply operation during emergency drive
- Master is in the stop state while the inverter is running.

- *2 During position control, the servo ON/OFF status is switched along with state transition. The LX signal input using Inverter Control Parameters (P20488 and P20489) (page 186) is disabled.
- *3 When the output is shut off by the MRS signal or other signal, the RY signal remains OFF.
- *4 The inverter state is forcefully changed to S4 during emergency drive operation.
- *5 For details of Pr.1103 and Pr.815, refer to the Instruction Manual (Function).

- Transition No.

Symbol	Description	Remarks
(0)	Power supply ON	
(1)	OFF command from the master	When the master is not the operation command source, status transition will not occur.
(2)	ON command from the master	
(3)	Enable operation command from the master	When the inverter is not in the drive enabled state, status transition will not occur.
(4)	Disable operation command from the master	Even when the RY signal turns OFF, status transition will occur. (Servo-ON status is canceled and the start command is turned OFF.)
(5)	OFF command from the master	
(6)	Coast stop command from the master Quick stop command from the master	
(7)	Coast stop command from the master Quick stop command from the master	
(8)	Coast stop command from the master	
(9)	OFF command from the master	
(10)	Quick stop command from the master	
(11)	Motor stop Disable operation command from the master	
(12)	Quick stop command from the master	
(13)	ON command from the master	
(14)	Motor stop	Status transition will occur even while the master is in the stop state.
(15)	Coast stop command from the master	
(16)	Process data communication interrupted (Pr.502 = "1 or 2")	
(17)	Process data communication restarted (Pr.502 = "2")	
(18)	Process data communication interrupted (Pr.502 = "1 or 2")	
(19)	Process data communication restarted (Pr.502 = "2")	
(20)	Quick stop command from the master (Pr.502 = "1")	When the process data communication with the master is not restarted, status transition will not occur.

NOTE

- Depending on packets sent to the inverter while the master is in the stop state, the inverter state may not be changed to S1. The run/stop state is determined by IOCS of the packet sent from the master to the inverter (Good (80h): run, Bad (60h): stop). When the following master is used, the above-mentioned operation is performed in the stop state.

Manufacturer	Model	Version
SIEMENS	SIMATIC S7-1500	CPU: 1511F-1 PN Product number: 6ES7511-1FK02-0AB0 Firmware version: V 02.05.02

- Command and control word 1 (STW1) combinations

Command	STW1				Operation	Transition No.
	Bit 3 (Enable Operation)	Bit 2 (No Quick Stop)	Bit 1 (No Coast Stop)	Bit 0 (ON)		
OFF	—	1	1	0	Transition to S2	(1)
ON	—	1	1	1	Transition to S3	(2)
Enable operation	1	1	1	1	Operation	(3)
Disable operation	0	1	1	1	Stop	(4)
Quick stop	—	0	—	—	Emergency stop (deceleration stop)	(6), (7)
Coast stop	—	—	0	—	Output shutoff (coasting to stop)	(6), (7)

Example) 50 Hz forward rotation command from the master to the inverter

STW1 = 1135 (046Fh)

b15 b0

0	0	0	0	0	1	0	0	0	1	1	0	1	1	1	1	1
---	---	---	---	---	---	---	---	---	---	---	---	---	---	---	---	---

NSOLL_A = (5000 (50 Hz) × 16384 (4000h)) / 12000 (Pr.1 = 120 Hz) = 6827 (1AABh)

◆ Drive Profile Parameters (Acyclic Data Exchange)

PNU numbers 0 to 65535 are assigned to parameters used for PROFINET: PROFIdrive parameters, PROFINET parameters, inverter parameters, monitor data, inverter control parameters, and CiA402 drive profile.

Item	Name	Setting value
API number	API_No	3A00h
Slot number	Slot_No	1h
Subslot number	SubSlot_No	1h
Index	Index	2Fh

■ PROFIdrive Parameters

The following parameters are implemented.

Group	PNU	Name	Access	Data Type	Description
PROFIdrive parameter	P915	Selection switch Setpoint telegram	R	Array[n] Unsigned16	Holds the configuration of the Setpoint Telegram.
	P916	Selection switch Actual value telegram	R	Array[n] Unsigned16	Holds the configuration of the Actual value Telegram.
	P922	Telegram Selection	R	Unsigned16	Initial value: Standard Telegram 1 Reflects the latest accepted configuration data from the master.
	P944	Fault message counter	R	Unsigned16	Incremented by 1 when Fault numbers (P947) is changed.
	P947	Fault numbers	R	Array[8] Unsigned16	Holds up to eight fault codes which occurred after the power is turned ON. When the ninth fault occurs, the eighth fault is overwritten by the new data.
	P964	Drive Unit identification	R	Array[5] Unsigned16	Manufacturer ID: 021Ch (Mitsubishi Electric) Drive unit type: 0 Version (software): xxyy (decimal) Firmware date (year): 0000 (unsupported) Firmware date (day/month): 0000 (unsupported)
	P965	Profile identification number	R	Octetstring2	Byte 0: 3 (PROFIdrive profile) Byte 1: 42 (Version 4.2)
	P967	STW1	R	V2	Last control word received from the controller.
	P968	ZSW	R	V2	Current status word received from the inverter.
	P972	Drive reset	R/W	Unsigned16	Writing "2" and then "1" resets the inverter.
	P975	DO identification	R	Array[8] Unsigned16	Manufacturer ID: 021Ch (Mitsubishi Electric) Drive object type: 0 Version (software): xxyy (decimal) Firmware date (year): 0000 (unsupported) Firmware date (day/month): 0000 (unsupported) PROFIdrive DO type class: 1 (Axis) PROFIdrive DO sub class 1: 1 (Application Class 1 supported) Drive Object ID (DO-ID): 1 (Number of Drive Objects (DO))
	P980	Parameter Database Handling and Identification	R	Array[n] Unsigned16	All the supported PNU numbers are saved in the subindices. Arrays are assigned in the following order: PROFIdrive parameters, PROFINET parameters, inverter parameters, monitor data, inverter control parameters, and CiA402 drive profile. The first parameter of the list of PNU numbers is marked by a subindex with the value "0".
Inverter parameter	P12288 to P16383	Inverter Parameters	R/W	Array[n] Unsigned16	The inverter parameter number + 12288 (3000h) is the PNU number.
Monitor data	P16384 to P20479	Monitor Data	R	Unsigned16	The monitor code + 16384 (4000h) is the PNU number.
Inverter control parameter	P20480 to P24575	Inverter Control Parameters	R/W	Unsigned16	Inverter control parameter
CiA402 drive profile	P24576 to P28671	CiA402 Drive Profile	R/W	—	CiA402 drive profile

Group	PNU	Name	Access	Data Type	Description
PROFINET parameter	P61000	Name of station	R	Octetstring240	Station name of device
	P61001	IP address	R	Octetstring4	Current IP address
	P61002	MAC address	R	Octetstring6	MAC address
	P61003	Gateway	R	Octetstring4	Current gateway address
	P61004	Subnet mask	R	Octetstring4	Current subnet mask

- Selection switch Setpoint telegram, Selection switch Actual value telegram (P915/P916)

PNU	Sub	Access	Name	Data Type	Description	Default
915	0 to n	R	Selection switch Setpoint telegram	Array[n] Unsigned16	Setpoint data assigned to the cyclic data is sent back.	—
916	0 to n	R	Selection switch Actual value telegram	Array[n] Unsigned16	Actual value data assigned to the cyclic data is sent back.	—

Details of the read values are as follows.

Signal number	Description
1	Control word 1 (STW1)
2	Status word 1 (ZSW1)
5	Speed setpoint A (NSOLL_A)
6	Speed actual value A (NIST_A)
100	Target torque
101	Actual torque
12288 to 16383	Inverter Parameters
16384 to 20479	Monitor Data
20480 to 24575	Inverter Control Parameters
24576 to 28671	CiA402 Drive Profile

- Telegram Selection (P922)

PNU	Sub	Access	Name	Data Type	Description	Default
922	0	R	Telegram selection	Unsigned16	The selected telegram is sent back.	1

Details of the read values are as follows.

Value	Description
1	Standard Telegram 1
100	Telegram 100
102	Telegram 102

- Fault message counter (P944)

PNU	Sub	Access	Name	Data Type	Description	Default
944	0	R	Fault message counter	Unsigned16	The value of Fault message counter is sent back. This value is incremented when an inverter fault occurs.	0

- Fault numbers (P947)

PNU	Sub	Access	Name	Data Type	Description	Default
947	0 to 7	R	Fault numbers	Array[8] Unsigned16	Displays up to eight inverter fault codes for the faults which occurred after the power is turned ON. While no fault occurs, "0" is read for P947.0 to 7.	0

- Drive Unit identification (P964)

The inverter identification information is sent back.

PNU	Sub	Access	Name	Data Type	Description	Default
964	0	R	Drive Unit identification	Array[5] Unsigned16	Manufacturer ID: Manufacturer ID of Mitsubishi Electric	540
	1				Device type	0
	2				Firmware version: Inverter firmware version	—

- Profile identification number (P965)

PNU	Sub	Access	Name	Data Type	Description	Default
965	0	R	Profile identification number	Octetstring2	Profile Number 3	03h
	1				Profile Version Number 42	2Ah

- STW1, ZSW1 (P967/P968)

Refer to details on the control word 1 (STW1) (page 177) and the status word 1 (ZSW1) (page 178).

- Drive reset (P972)

PNU	Sub	Access	Name	Data Type	Description	Default
972	0	R/W	Drive reset	Unsigned16	0: Initial status (or status after a reset) 1: Power-on Reset (initiation) 2: Power-on Reset (preparation) The value "0" is read-only. Writing "2" and then "1" resets the inverter.	0

- DO identification (P975)

The drive object identification information is sent back.

PNU	Sub	Access	Name	Data Type	Description	Default
975	0	R	DO identification	Array[8] Unsigned16	Manufacturer ID: Manufacturer ID of Mitsubishi Electric	540
	1				Drive Object type	0
	2				Firmware version: Inverter firmware version	—
	5				PROFIdrive DO type class 1: Axis	1
	6				PROFIdrive DO sub class 1 1: Application Class 1 supported	1
	7				Drive Object ID (DO-ID) Number of Drive Objects(DO)	1

- Parameter Database Handling and Identification (P980)

PNU	Sub	Access	Name	Data Type	Description	Default
980	0 to n	R	Parameter Database Handling and Identification	Array[n] Unsigned16	All supported PNU numbers are listed in the following order: PROFIdrive parameters, PROFINET parameters, inverter parameters, monitor data, inverter control parameters, and CiA402 drive profile.	—

Among the PNU numbers specified in the subindices, up to 117 numbers are shown. (Number of elements (234 max.) / Unsigned16 (2 bytes))

When "1" is set in the subindex and "3" is set for the number of elements, P916, P922, and P944 are displayed.

- Inverter Parameters (P12288 to P16383)

PNU	Sub	Access	Name	Data Type	Description	Default
12288 to 16383	0, 1	R/W	Inverter Parameters	Array[n] Unsigned16	The inverter parameter number + 12288 (3000h) is the PNU number.	—

Calibration parameters

PNU	Sub	Name	Description
13188 (3384h)	0	Data	C0 (Pr.900)
	1	Sub Data	—
13189 (3385h)	0	Data	C1 (Pr.901)
	1	Sub Data	—
13190 (3386h)	0	Data	C2 (Pr.902)
	1	Sub Data	C3 (Pr.902)
13191 (3387h)	0	Data	125 (Pr.903)
	1	Sub Data	C4 (Pr.903)
13192 (3388h)	0	Data	C5 (Pr.904)
	1	Sub Data	C6 (Pr.904)
13193 (3389h)	0	Data	126 (Pr.905)
	1	Sub Data	C7 (Pr.905)
13205 (3395h)*1	0	Data	C12 (Pr.917)
	1	Sub Data	C13 (Pr.917)
13206 (3396h)*1	0	Data	C14 (Pr.918)
	1	Sub Data	C15 (Pr.918)
13207 (3397h)*1	0	Data	C16 (Pr.919)
	1	Sub Data	C17 (Pr.919)
13208 (3398h)*1	0	Data	C18 (Pr.920)
	1	Sub Data	C19 (Pr.920)
13220 (33A4h)	0	Data	C38 (Pr.932)
	1	Sub Data	C39 (Pr.932)
13221 (33A5h)	0	Data	C40 (Pr.933)
	1	Sub Data	C41 (Pr.933)
13222 (33A6h)	0	Data	C42 (Pr.934)
	1	Sub Data	C43 (Pr.934)
13223 (33A7h)	0	Data	C44 (Pr.935)
	1	Sub Data	C45 (Pr.935)

*1 Available only when the FR-E8AXY is installed.

For the numbers and names of inverter parameters, refer to the parameter list of the Instruction Manual (Function).

NOTE

- Set 65520 (FFF0h) as a parameter value "8888" and 65535 (FFFFh) as "9999".
- When parameter write is performed, data are written to RAM for Cyclic Data Exchange. Writing to EEPROM or RAM is selected according to the setting in **Pr.342 Communication EEPROM write selection** for Acyclic Data Exchange.

- Monitor Data (P16384 to P20479)

PNU	Sub	Access	Name	Data Type	Description	Default
16384 to 20479	0	R	Monitor Data	Unsigned16	The monitor code + 16384 (4000h) is the PNU number.	—

For details of the monitor codes and monitor items, refer to the description of **Pr.52** in the Instruction Manual (Function).

NOTE

- Display of negative numbers during monitoring set in **Pr.290 Monitor negative output selection** is disabled.
- The display can be changed from the frequency to rotations per minute (machine speed) using **Pr.53**. When the machine speed is displayed, the value is incremented by one.

- Inverter Control Parameters (P20480 to P24575)

PNU	Sub	Access	Name	Data Type	Description	Default
20480 to 24575	0	R/W	Inverter Control Parameters	Unsigned16	Inverter control parameter	—

PNU	Name	Access	Description
20482 (5002h) ^{*1}	Inverter reset	R/W	Set 9966h for the written value. The read value is fixed to 0000h.
20483 (5003h) ^{*1}	Parameter clear	R/W	Set 965Ah for the written value. The read value is fixed to 0000h.
20484 (5004h) ^{*1}	All parameter clear	R/W	Set 99AAh for the written value. The read value is fixed to 0000h.
20486 (5006h) ^{*1}	Parameter clear ^{*2}	R/W	Set 5A96h for the written value. The read value is fixed to 0000h.
20487 (5007h) ^{*1}	All parameter clear ^{*2}	R/W	Set AA99h for the written value. The read value is fixed to 0000h.
20488 (5008h)	Inverter status / control input command (extended) ^{*3}	R/W	Refer to page 187 .
20489 (5009h)	Inverter status / control input command ^{*3}	R/W	Refer to page 187 .
20981 (51F5h)	Fault record 1	R/W	Being 2 bytes in length, the data is stored as "00○○h". Refer to the lowest 1 byte for the error code. (For details on error codes, refer to the list of fault displays in the Instruction Manual (Maintenance).) The fault history is batch-cleared by writing to 20981 (51F5h). Set any value as data.
20982 (51F6h)	Fault record 2	R	
20983 (51F7h)	Fault record 3	R	
20984 (51F8h)	Fault record 4	R	
20985 (51F9h)	Fault record 5	R	
20986 (51FAh)	Fault record 6	R	
20987 (51FBh)	Fault record 7	R	
20988 (51FCh)	Fault record 8	R	
20989 (51FDh)	Fault record 9	R	
20990 (51FEh)	Fault record 10	R	
20992 (5200h) ^{*4}	Safety input status	R	Refer to page 188 .

*1 Not available for Cyclic Data Exchange.

*2 Settings in the communication parameters are not cleared.

*3 The data is written as a control input command for writing.
The data is read as the inverter status for reading.

*4 Parameter setting is available for the Ethernet model only. Access to the parameter using Acyclic Data Exchange is allowed for the safety communication model and the IP67 model, but the function is disabled.

Inverter status / control input command, and inverter status / control input command (extended)

Inverter status / control input command			Inverter status / control input command (extended)		
Bit	Definition		Bit	Definition	
	Control input command	Inverter status		Control input command	Inverter status
0	—	RUN (Inverter running) ^{*2}	0	NET X1 (—) ^{*1}	NET Y1 (0) ^{*2}
1	—	During forward rotation	1	NET X2 (—) ^{*1}	NET Y2 (0) ^{*2}
2	—	During reverse rotation	2	NET X3 (—) ^{*1}	NET Y3 (0) ^{*2}
3	RH (High-speed operation command) ^{*1}	Up to frequency	3	NET X4 (—) ^{*1}	NET Y4 (0) ^{*2}
4	RM (Middle-speed operation command) ^{*1}	Overload alarm	4	NET X5 (—) ^{*1}	0
5	RL (Low-speed operation command) ^{*1}	0	5	—	0
6	JOG operation selection 2	FU (Output frequency detection) ^{*2}	6	—	0
7	Second function selection	ABC (Fault) ^{*2}	7	—	0
8	Terminal 4 input selection	ABC2 (0) ^{*2}	8	—	0
9	—	Safety monitor output 2	9	—	0
10	MRS (Output stop) ^{*1}	0	10	—	0
11	—	0	11	—	0
12	RES (—) ^{*1}	0	12	—	0
13	—	0	13	—	0
14	—	0	14	—	0
15	—	Fault occurrence	15	—	0

*1 The signal within parentheses () is assigned in the initial status. The function changes depending on the setting of **Pr.180 to Pr.189 (Input terminal function selection)**.

For details, refer to the description of **Pr.180 to Pr.189 (Input terminal function selection)** in the Instruction Manual (Function).

The signals assigned to the input terminals may be valid or invalid in the NET operation mode. (Refer to the Instruction Manual (Function).)

*2 The signal within parentheses () is assigned in the initial status. The function changes depending on the setting of **Pr.190 to Pr.197 (Output terminal function selection)**.

For details, refer to the description of **Pr.190 to Pr.197 (Output terminal function selection)** in the Instruction Manual (Function).

Safety input status

Bit	Definition
0	0: Terminal S1 ON 1: Terminal S1 OFF (output shutoff)
1	0: Terminal S2 ON 1: Terminal S2 OFF (output shutoff)
2 to 15	0

• CiA402 Drive Profile (P24576 to P28671)

PNU	Sub	Name	Description	Access	Data type
24639 (603Fh)	0	Error code	Error number The error code of the latest fault that occurred after power-ON or an inverter reset is returned. When no fault occurs, no error is returned. When the fault history is cleared during occurrence of a fault, no error is returned. The upper eight bits are fixed to FF, and the lower eight bits represent the error code. (FFXXh: "XX" represents the error code.) (For details on error codes, refer to the list of fault displays in the Instruction Manual (Maintenance).)	R	Unsigned16
24643 (6043h)	0	vl velocity demand	Output frequency (r/min) ^{*1} The output frequency is read in r/min. Monitoring range: -32768 (8000h) to 32767 (7FFFh) When Pr.81 = "9999", the number of motor poles is regarded as 4.	R	Integer16
24644 (6044h)	0	vl velocity actual value	Operation speed (r/min) ^{*1} The operation speed is read in r/min. Monitoring range: -32768 (8000h) to 32767 (7FFFh) When Pr.81 = "9999", the number of motor poles is regarded as 4.	R	Integer16
24672 (6060h)	0	Modes of operation	Control mode: -1 (vendor specific operation mode) (fixed)	R/W	Integer8
24673 (6061h)	0	Modes of operation display	Current control mode: -1 (vendor specific operation mode) (fixed)	R	Integer8
24674 (6062h)	0	Position demand value	Position command (pulse) The position command before the electronic gear operation is read.	R	Integer32
24675 (6063h)	0	Position actual internal value	Current position (pulse) The current position after the electronic gear operation is read.	R	Integer32
24676 (6064h)	0	Position actual value	Current position (pulse) The current position before the electronic gear operation is read.	R	Integer32
24689 (6071h)	Function disabled				
24692 (6074h)	0	Torque demand	Torque demand value (%) The torque command is read.	R	Integer16
24695 (6077h)	0	Torque actual value	Torque actual value (%) The motor torque is read.	R	Integer16
24698 (607Ah)	0	Target position	Target position (pulse) Set the target position in the direct command mode. Initial value: 0 Setting range: -2147483647 to 2147483647 (For the direct command mode, refer to the FR-E800 Instruction Manual (Function).)	R/W	Integer32
24703 (607Fh)	0	Max profile velocity	Maximum profile speed (r/min) Set Pr.18 High speed maximum frequency in r/min. Setting range: 0 to 590 Hz	R/W	Unsigned32
24705 (6081h)	0	Profile velocity	Profile speed (r/min) Set the maximum speed in the direct command mode. Initial value: 0 Setting range: 0 to (120 × 590 Hz / Pr.81) (For the direct command mode, refer to the FR-E800 Instruction Manual (Function).)	R/W	Unsigned32

PNU	Sub	Name	Description	Access	Data type
24707 (6083h)	0	Profile acceleration	Acceleration time constant (ms) <Position control> Set the acceleration time in the direct command mode. Initial value: 5000 Setting range: 10 to 360000 The last digit is rounded off. (For example, 1358 ms becomes 1350 ms.) (For the direct command mode, refer to the FR-E800 Instruction Manual (Function).) <Other than position control> Set Pr.7 Acceleration time in ms. Setting range: 0 to 3600 s The last two digits are rounded off when Pr.21 Acceleration/ deceleration time increments = "0", and the last digit is rounded off when Pr.21 = "1".	R/W	Unsigned32
24708 (6084h)	0	Profile deceleration	Deceleration time constant (ms) <Position control> Set the deceleration time in the direct command mode. Initial value: 5000 Setting range: 10 to 360000 The last digit is rounded off. (For example, 1358 ms becomes 1350 ms.) (For the direct command mode, refer to the FR-E800 Instruction Manual (Function).) <Other than position control> Set Pr.8 Deceleration time in ms. Setting range: 0 to 3600 s The last two digits are rounded off when Pr.21 Acceleration/ deceleration time increments = "0", and the last digit is rounded off when Pr.21 = "1".	R/W	Unsigned32
24719 (608Fh)	—	Position encoder resolution	Encoder resolution (machine side / motor side)	—	—
	0	Highest sub-index supported	Maximum value of subindex: 02h (fixed)	R	Unsigned8
	1	Encoder increments	Encoder resolution Set Pr.369 Number of encoder pulses . Setting range: 2 to 4096	R/W	Unsigned32
	2	Motor revolutions	Motor speed (rev): 00000001h (fixed)	R/W	Unsigned32
24721 (6091h)	—	Gear ratio	Gear ratio	—	—
	0	Highest sub-index supported	Maximum value of subindex: 02h (fixed)	R	Unsigned8
	1	Motor revolutions	Motor shaft revolutions ^{*2} Set Pr.420 Command pulse scaling factor numerator (electronic gear numerator) . Setting range: 1 to 32767	R/W	Unsigned32
	2	Shaft revolutions	Drive shaft revolutions ^{*2} Set Pr.421 Command pulse multiplication denominator (electronic gear denominator) . Setting range: 1 to 32767	R/W	Unsigned32
24728 (6098h)	0	Homing method	Home position return method Set the home position return method in the direct command mode. ^{*3} (For the direct command mode and the home position return method, refer to the FR-E800 Instruction Manual (Function).)	R/W	Integer8
24729 (6099h)	—	Homing speeds	Home position return speed	—	—
	0	Highest sub-index supported	Maximum value of subindex: 01h (fixed)	R	Unsigned8
	1	Speed during search for switch	Motor speed during home position returning (r/min) Set the home position return speed in the direct command mode. Initial value: 120 × 2 Hz / Pr.81 Setting range: 0 to (120 × 400 Hz / Pr.81) (For the direct command mode, refer to the FR-E800 Instruction Manual (Function).)	R/W	Unsigned32

PNU	Sub	Name	Description	Access	Data type
24730 (609Ah)	0	Homing acceleration	Home position return acceleration/deceleration time (ms) Set the home position return acceleration/deceleration time in the direct command mode. Initial value: 5000 Setting range: 10 to 360000 The last digit is rounded off. (For example, 1358 ms becomes 1350 ms.) (For the direct command mode, refer to the FR-E800 Instruction Manual (Function).)	R/W	Unsigned32
24820 (60F4h)	0	Following error actual value	Droop pulse (pulse) The droop pulse before the electronic gear operation is read.	R	Integer32
24826 (60FAh)	0	Control effort	Speed command after position loop*1 The ideal speed command is read.	R	Integer32
24828 (60FCh)	0	Position demand internal value	Position command (pulse) The position command after the electronic gear operation is read.	R	Integer32
25858 (6502h)	0	Supported drive modes	Supported control mode: 00010000h (vendor specific operation mode)	R	Unsigned32

*1 The value is displayed and set in r/min regardless of the settings in **Pr.53**.

The frequency is converted to the rotation speed for reading, and the setting value is converted to the frequency for writing.

*2 When parameter write is performed, data are written to RAM for Cyclic Data Exchange. Writing to EEPROM or RAM is selected according to the setting in **Pr.342 Communication EEPROM write selection** for Acyclic Data Exchange.

*3 The following table shows home position return methods corresponding to P24728 (6098h) setting values.

P24728 (6098h) setting	Home position return method
-3	Data set type
-4	Stopper type (home position return direction: position pulse increasing direction)
-5 (initial value)	Ignoring the home position (servo ON position as the home position)
-7	Count type with front end reference (home position return direction: position pulse increasing direction)
-36	Stopper type (home position return direction: position pulse decreasing direction)
-39	Count type with front end reference (home position return direction: position pulse decreasing direction)
-65	Stopper type (home position return direction: start command direction)
-66	Count type with front end reference (home position return direction: start command direction)

NOTE

- The command interface in the Network operation mode is determined by the **Pr.550 NET mode operation command source selection** setting. (Refer to the FR-E800 Instruction Manual (Function).)
- When the data is read, the value is displayed with a sign regardless of the **Pr.290 Monitor negative output selection** setting.

- Name of station (P61000)

PNU	Sub	Access	Name	Data Type	Description	Default
61000	0 to 239	R	Name of station	Octetstring240	Device name	FR-E800-(SC)E

- IP address (P61001)

PNU	Sub	Access	Name	Data Type	Description	Default
61001	0	R	IP address	Octetstring4	IP address first octet	—
	1				IP address second octet	—
	2				IP address third octet	—
	3				IP address fourth octet	—

- MAC address (P61002)

PNU	Sub	Access	Name	Data Type	Description	Default
61002	0	R	MAC address	Octetstring6	MAC address (upper)	—
	1				MAC address	—
	2				MAC address	—
	3				MAC address	—
	4				MAC address	—
	5				MAC address (lower)	—

- Gateway (P61003)

PNU	Sub	Access	Name	Data Type	Description	Default
61003	0	R	Gateway	Octetstring4	Gateway address first octet	—
	1				Gateway address second octet	—
	2				Gateway address third octet	—
	3				Gateway address fourth octet	—

- Subnet mask (P61004)

PNU	Sub	Access	Name	Data Type	Description	Default
61004	0	R	Subnet mask	Octetstring4	Subnet mask first octet	255
	1				Subnet mask second octet	255
	2				Subnet mask third octet	255
	3				Subnet mask fourth octet	0

■ PROFIdrive parameter request format (master to inverter)

	Byte No.	Field	Description	Parameter read	Parameter change
Header	0	Request reference	Determined by the setting in the master	○	○
	1	Request ID	Parameter read: 01h Parameter change: 02h	○	○
	2	DO-ID	01h	○	○
	3	Number of parameters	01h	○	○
Parameter address	4	Attribute	10h	○	○
	5	Number of elements (n)	Determined by the number of arrays (234 max.) 0 or 1 for data types other than array or octetstring	○	○
	6	PNU number	Refer to page 183 .	○	○
	7			○	○
	8	Sub-index		○	○
9	○			○	
Parameter value	10	Format	Data Type Unsigned16: 06h Octetstring: 0Ah V2: 73h	×	○
	11	Number of data	Number of arrays	×	○
	12	Parameter value	Parameter writing value	×	○
	13			×	○
	14 to 237			×	○ ^{*1}
	238			×	○ ^{*1}
239	×			○ ^{*1}	

*1 Availability depends on the format or data size.

■ PROFIdrive parameter response format (inverter to master)

	Byte No.	Field	Description	Parameter read		Parameter change	
				Positive	Negative	Positive	Negative
Header	0	Request reference	Determined by the setting in the master	○	○	○	○
	1	Request ID	Parameter read (positive): 01h Parameter change (positive): 02h Parameter read (negative): 81h Parameter change (negative): 82h Request ID fault: 80h	○	○	○	○
	2	DO-ID	01h	○	○	○	○
	3	Number of parameters	01h	○	○	○	○

	Byte No.	Field	Description	Parameter read		Parameter change	
				Positive	Negative	Positive	Negative
Parameter value	4	Format	Data Type Unsigned16: 06h Octetstring: 0Ah V2: 73h 44h for error response	○	○	×	○
	5	Number of data	Number of arrays	○	○	×	○
	6	Parameter value / error number	Parameter reading value or error number	○	○	×	○
	7			○	○	×	○
	8			○ ^{*1}	×	×	×
	9			○ ^{*1}	×	×	×
	10 to 237			○ ^{*1}	×	×	×
	238			○ ^{*1}	×	×	×
	239			○ ^{*1}	×	×	×

*1 Availability depends on the format or data size.

■ Error number

Error No.	Name	Description
00h	Impermissible parameter number	Access is attempted to a nonexistent PROFIdrive parameter.
01h	Parameter value cannot be changed	Writing is attempted to a writing-disabled PROFIdrive parameter.
02h	Low or high limit exceeded	Setting is out of range.
03h	Faulty subindex	Access is attempted to a nonexistent subindex.
04h	No array	Access is attempted to a PROFIdrive parameter which does not have a subindex.
05h	Incorrect data type	Data type does not match.
11h	Request cannot be executed because of operating state	Access is disabled temporarily due to the operating status.
16h	Parameter address impermissible	Value, number of elements, or PNU number is invalid for the subindex.
17h	Illegal format	PROFIdrive parameter data format is invalid.
19h	Axis/DO nonexistent	Access is attempted to a nonexistent shaft or object.
21h	Service not supported	Service is out of range. (Request ID is invalid.)
23h	Multi parameter access not supported	Access is attempted to multiple parameters at the same time.

◆ Programming examples

The following explains the programming examples for controlling the inverter with sequence programs when Standard Telegram 1 is selected.

Check that "34962" (PROFINET) is set in any of **Pr.1427 to Pr.1430** (Ethernet function selection).

■ Programming example for forward rotation operation at 50 Hz

- Network setting and device examples

Device name	Description
M0	Inverter forward rotation
D0.0	DataExchangeStartRequest
D109	Control word 1 (STW1)
D109.0	ON/OFF
D109.1	No Coast Stop/Coast Stop
D109.2	No Quick Stop/Quick Stop
D109.3	Enable/Disable Operation
D109.4	—
D109.5	Unfreeze/Freeze Ramp Generator
D109.6	Enable/Disable Setpoint
D109.7	Fault Acknowledge
D109.8	—
D109.9	—
D109.A	Control By PLC/No Control By PLC
D109.B	Target torque enabled
D109.C	Start command direction selection
D109.D to D109.F	—
D110	Speed setpoint A (NSOLL_A)
D111	Status word 1 (ZSW1)
D111.0	Ready To Switch On/Not Ready To Switch On
D111.1	Ready To Operate/Not Ready To Operate
D111.2	Operation Enabled (drive follows setpoint)/Operation Disabled
D111.3	Fault Present/No Fault
D111.4	Coast Stop Not Activated/Coast Stop Activated
D111.5	Quick Stop Not Activated/Quick Stop Activated
D111.6	Switching On Inhibited/Switching On Not Inhibited
D111.7	Warning Present/No Warning
D111.8	—
D111.9	Control Requested/No Control Requested
D111.A to D111.F	—
D112	Speed actual value A (NIST_A)

Programming example for state transition from S1 (Switching On Inhibited) to S3 (Switched On) (For the state transition diagram, refer to [page 180](#).)

- Set frequency: Speed setpoint A (NSOLL_A)

$$\text{NSOLL_A} = (5000 (50 \text{ Hz}) \times 16384 (4000\text{h})) / 12000 (\text{Pr.1} = 120 \text{ Hz}) = 6826 (1\text{AAAh})$$

Turning ON M0 starts operation at 50 Hz.

Turning OFF M0 stops operation.

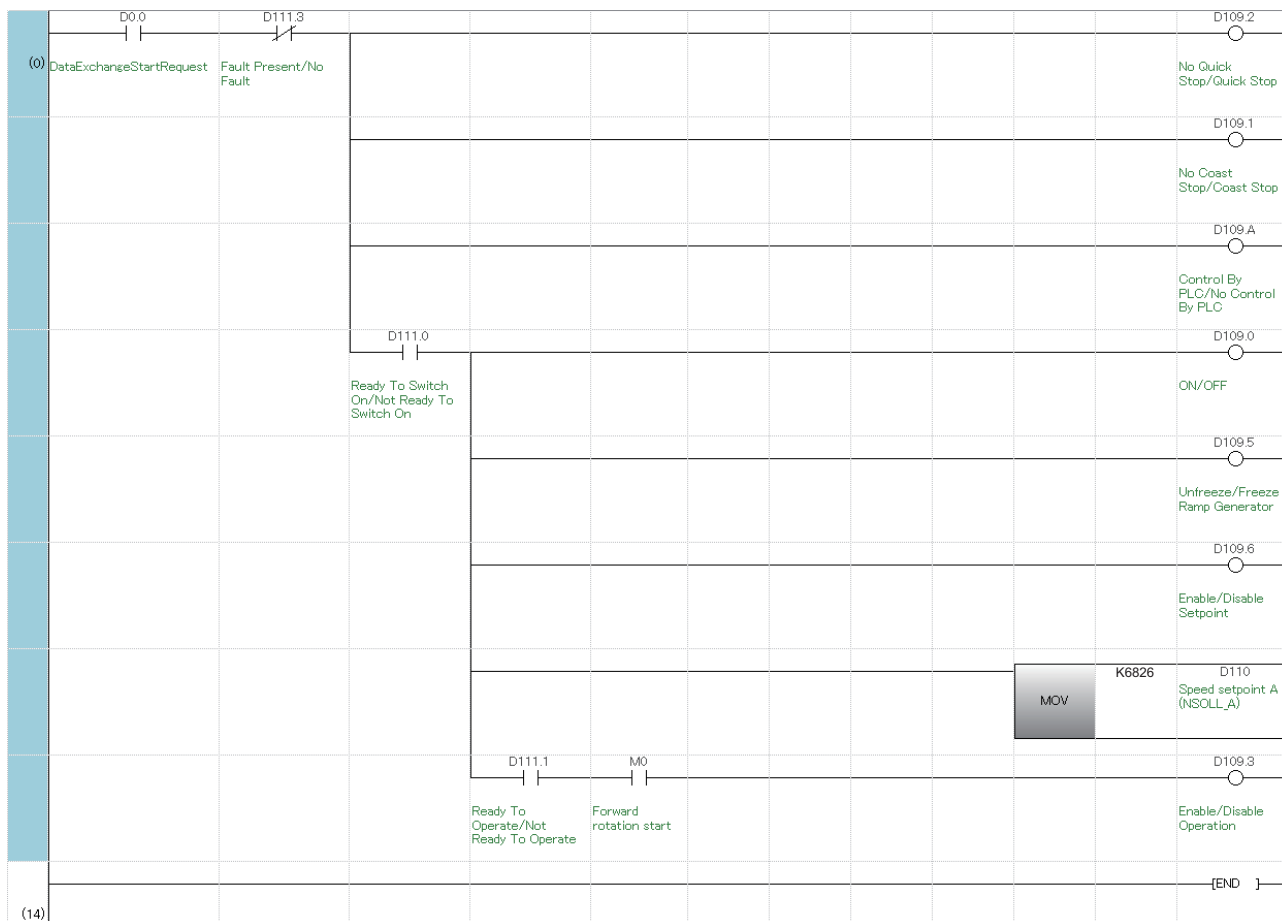

◆ Setting example

- The following tables show example settings when user defined cyclic communication data are selected (Telegram 102). When bit 10 of Control word 1 (STW1) is turned ON, data are written to the inverter. While bit 10 of Control word 1 (STW1) is ON, the data is always updated. (The response time to write the data is 100 ms at the most.)
- Telegram 102

Type	IO Data number	Name
Setpoint Telegram (master to inverter)	1	Control word 1 (STW1)
	2	Pr.1320
	3	Pr.1321
	4	Pr.1322
Actual Value Telegram (inverter to master)	1	Status word 1 (ZSW1)
	2	Pr.1330
	3	Pr.1331
	4	Pr.1332
	5	Pr.1333
	6	Pr.1334
	7	Pr.1335

- Parameters

Pr.	Name	Setting example	Remarks
1320	User Defined Cyclic Communication Input 1 Mapping	5 (5h)	Speed setpoint A (NSOLL_A)
1321	User Defined Cyclic Communication Input 2 Mapping	12295 (3007h)	P.7 Acceleration time 7 (0007h) + 12288 (3000h)
1322	User Defined Cyclic Communication Input 3 Mapping	12296 (3008h)	Pr.8 Deceleration time 8 (0008h) + 12288 (3000h)
1330	User Defined Cyclic Communication Output 1 Mapping	6 (6h)	Speed actual value A (NIST_A)
1331	User Defined Cyclic Communication Output 2 Mapping	12295 (3007h)	P.7 Acceleration time 7 (0007h) + 12288 (3000h)
1332	User Defined Cyclic Communication Output 3 Mapping	12296 (3008h)	Pr.8 Deceleration time 8 (0008h) + 12288 (3000h)
1333	User Defined Cyclic Communication Output 4 Mapping	16386 (4002h)	Monitored output current 2 (0002h) + 16384 (4000h)
1334	User Defined Cyclic Communication Output 5 Mapping	12543 (30FFh)	Pr.255 Life alarm status display 255 (00FFh) + 12288 (3000h)
1335	User Defined Cyclic Communication Output 6 Mapping	20981 (51F5h)	Fault record 1

- Connection settings in the engineering software

Set "Telegram 102" for the "Module Configuration" setting of the inverter.

Names of setting items may differ depending of the engineering software used.

2.13 EtherCAT

2.13.1 Outline



EtherCAT is available only for the FR-E800-(SC)EPC.

Operation or parameter setting via communication is possible using the EtherCAT through the Ethernet connector on the inverter.

This function is not supported depending on the date of manufacture of the inverter. For details of specification changes, refer to [page 290](#).

◆ Communication specifications

Item		Description
Communication speed		100 Mbps (Full duplex)
Maximum number of connected units		65535 ^{*1}
Connection cable		Ethernet cable (IEEE 802.3 100BASE-TX compliant cable and ANSI/TIA/EIA-568-B (Category 5e) compliant shielded 4-pair branched cable)
Topology		Line, star, ring, or a combination of line and star ^{*2}
PDO (Process Data Object) communication	Communication method	Cyclic communication
	Cycle time	Depends on the master
SDO (Service Data Object) communication	Communication method	Mailbox communication (acyclic communication)
Synchronization mode		Free-run mode Local cycle time: 4 ms

*1 The number varies depending on the specification of the master.

*2 For star or ring topology, a general-purpose switching hub cannot be used. Use an EtherCAT branch slave.

◆ Wiring method

- For the FR-E800-(SC)EPC, PORT1 is the IN connector and PORT2 is the OUT connector. Use PORT1 for connection with the master or the upstream station, and use PORT2 for connection with the downstream station.

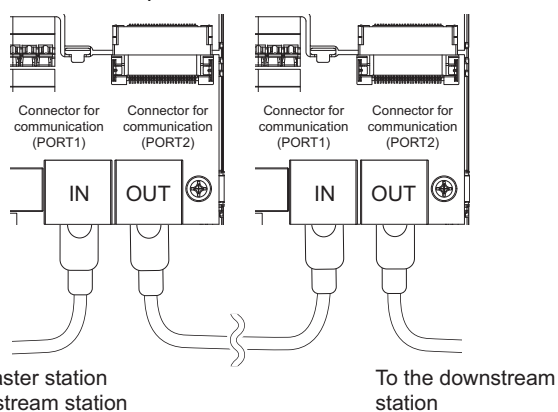

◆ Operation status LEDs

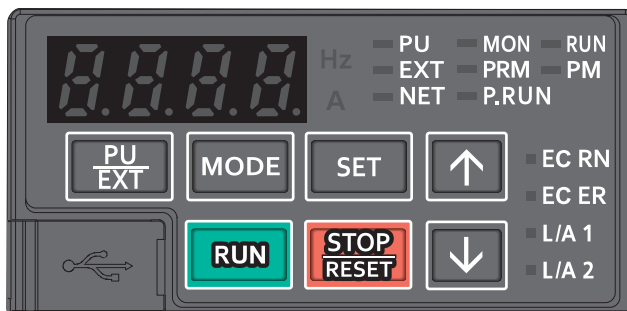

LED name	Description	LED status	Remarks
EC RN	EtherCAT state machine (ESM) status	OFF	Power-OFF / Init state
		Blinking green (200 ms intervals)	Pre-Operational state
		Flashing green, 1 flash	Safe-Operational state
		Blinking green (50 ms intervals)	Initialization state
		Solid green	Operational state
EC ER	Error status	OFF	No error.
		Blinking red (200 ms intervals)	EtherCAT state change commanded by the master is impossible.
		Flashing red, 1 flash	EtherCAT state is changed due to internal fault.
		Flashing red, 2 flashes	Watchdog fault of sync managers (SM).
		Blinking red (50 ms intervals)	An error is detected at a start.
L/A 1	Connector for communication (PORT1) status	OFF	Power-OFF/link-down
		Blinking green (50 ms intervals)	Link-up (Data reception in progress)
		Solid green	Link-up
L/A 2	Connector for communication (PORT2) status	OFF	Power-OFF/link-down
		Blinking green (50 ms intervals)	Link-up (Data reception in progress)
		Solid green	Link-up

◆ ESI file

An ESI file is available for download.

Mitsubishi Electric FA Global Website:

www.mitsubishielectric.com/fa/products/drv/inv/support/e800/network.html

The download is free at the website above. For details, contact your sales representative.

NOTE

- The ESI file is used in engineering software. To install the ESI file properly, refer to the instruction manual of the applicable engineering software.

2.13.2 Parameters related to EtherCAT

The following parameters are used for EtherCAT communication. Set the parameters as required.

Pr.	Name	Initial value	Setting range	Description
1305 N690 ^{*1}	EtherCAT node address setting	0	0 to 65535	Set the node address for the master to identify an inverter.

Pr.	Name	Initial value	Setting range	Description
1320 N810 ^{*1}	User Defined Cyclic Communication Input 1 Mapping	24642	12288 to 13787, 20488, 20489, 24642, 24646, 24648	Set the index number for inverter parameters, inverter control parameters, and CiA402 drive profile. Users can assign a function to the PDO mapping object RxPDO (mater to inverter). 9999: Function disabled
1321 to 1329 N811 to N819 ^{*1}	User Defined Cyclic Communication Input 2 to 10 Mapping	9999	to 24650, 24672, 24677 to 24680, 24689, 24698, 24702, 24703, 24705, 24707 to 24709, 24719, 24721, 24728 to 24730, 24831, 9999	
1330 N850 ^{*1}	User Defined Cyclic Communication Output 1 Mapping	24643	12288 to 13787, 16384 to 16483, 20488, 20489, 20981	Set the index number for inverter parameters, monitor data, inverter control parameters, and CiA402 drive profile. Users can assign a function to the PDO mapping object TxPDO (inverter to mater). 9999: Function disabled
1331 to 1343 N851 to N863 ^{*1}	User Defined Cyclic Communication Output 2 to 14 Mapping	9999	to 20990, 20992, 24639, 24643, 24644, 24673 to 24676, 24692, 24695, 24820, 24826, 24828, 25858, 9999	
1389 ^{*1}	User Defined Cyclic Communication Input Sub 1 and 2 Mapping	0	0 to 2, 256 to 258, 512 to 514	Pr.1389 (lower 8 bits): Subindex to which the index number is specified using Pr.1320 Pr.1389 (upper 8 bits): Subindex to which the index number is specified using Pr.1321
1390 ^{*1}	User Defined Cyclic Communication Input Sub 3 and 4 Mapping	0	0 to 2, 256 to 258, 512 to 514	Pr.1390 (lower 8 bits): Subindex to which the index number is specified using Pr.1322 Pr.1390 (upper 8 bits): Subindex to which the index number is specified using Pr.1323
1391 ^{*1}	User Defined Cyclic Communication Input Sub 5 and 6 Mapping	0	0 to 2, 256 to 258, 512 to 514	Pr.1391 (lower 8 bits): Subindex to which the index number is specified using Pr.1324 Pr.1391 (upper 8 bits): Subindex to which the index number is specified using Pr.1325
1392 ^{*1}	User Defined Cyclic Communication Input Sub 7 and 8 Mapping	0	0 to 2, 256 to 258, 512 to 514	Pr.1392 (lower 8 bits): Subindex to which the index number is specified using Pr.1326 Pr.1392 (upper 8 bits): Subindex to which the index number is specified using Pr.1327
1393 ^{*1}	User Defined Cyclic Communication Input Sub 9 and 10 Mapping	0	0 to 2, 256 to 258, 512 to 514	Pr.1393 (lower 8 bits): Subindex to which the index number is specified using Pr.1328 Pr.1393 (upper 8 bits): Subindex to which the index number is specified using Pr.1329
N830 to N839 ^{*1}	User Defined Cyclic Communication Input Sub 1 to 10 Mapping	0	0 to 2	Subindices to which the index numbers are specified using Pr.1320 to Pr.1329
1394 ^{*1}	User Defined Cyclic Communication Output Sub 1 and 2 Mapping	0	0 to 2, 256 to 258, 512 to 514	Pr.1394 (lower 8 bits): Subindex to which the index number is specified using Pr.1330 Pr.1394 (upper 8 bits): Subindex to which the index number is specified using Pr.1331
1395 ^{*1}	User Defined Cyclic Communication Output Sub 3 and 4 Mapping	0	0 to 2, 256 to 258, 512 to 514	Pr.1395 (lower 8 bits): Subindex to which the index number is specified using Pr.1332 Pr.1395 (upper 8 bits): Subindex to which the index number is specified using Pr.1333
1396 ^{*1}	User Defined Cyclic Communication Output Sub 5 and 6 Mapping	0	0 to 2, 256 to 258, 512 to 514	Pr.1396 (lower 8 bits): Subindex to which the index number is specified using Pr.1334 Pr.1396 (upper 8 bits): Subindex to which the index number is specified using Pr.1335
1397 ^{*1}	User Defined Cyclic Communication Output Sub 7 and 8 Mapping	0	0 to 2, 256 to 258, 512 to 514	Pr.1397 (lower 8 bits): Subindex to which the index number is specified using Pr.1336 Pr.1397 (upper 8 bits): Subindex to which the index number is specified using Pr.1337
1398 ^{*1}	User Defined Cyclic Communication Output Sub 9 and 10 Mapping	0	0 to 2, 256 to 258, 512 to 514	Pr.1398 (lower 8 bits): Subindex to which the index number is specified using Pr.1338 Pr.1398 (upper 8 bits): Subindex to which the index number is specified using Pr.1339
N870 to N879 ^{*1}	User Defined Cyclic Communication Output Sub 1 to 10 Mapping	0	0 to 2	Subindices to which the index numbers are specified using Pr.1330 to Pr.1339

*1 The setting is applied after an inverter reset or next power-ON.

NOTE

- The FR-E800-(SC)EPC does not support the following parameters.
 - Default gateway address (Pr.442 to Pr.445)
 - Inverter-to-inverter link function (Pr.1124 and Pr.1125)
 - Ethernet relay operation at reset selection (Pr.1386)
 - Inverter identification enable/disable selection (Pr.1399)
 - Ethernet communication network number (Pr.1424), Ethernet communication station number (Pr.1425)
 - Link speed and duplex mode selection (Pr.1426)
 - Ethernet function selection (Pr.1427 to Pr.1430)
 - Ethernet communication check time interval (Pr.1432)
 - IP address (Pr.1434 to Pr.1437)
 - Subnet mask (Pr.1438 to Pr.1441)
 - IP filtering function (Ethernet) (Pr.1442 to Pr.1448)
 - Ethernet IP address for command source selection (Pr.1449 to Pr.1454)
 - Keepalive time (Pr.1455)
 - Network diagnosis selection (Pr.1456)
- The FR-E800-EPC manufactured in August 2024 or earlier does not support the following parameter.
 - Extended setting for Ethernet signal loss detection function selection (Pr.1457)

◆ Node address setting

The node address is either automatically set by the master using the engineering software or set in the inverter parameter.

- Configured Station Alias (Setting by the master via EtherCAT communication, which is to be set in SII (Slave Information Interface) of the inverter)
Set Configured Station Alias using the engineering software. The setting becomes valid after next power ON of the inverter.
- Requesting ID (ID-Selector set in the inverter parameter)
Set Device ID to be used as Requesting ID in Pr.1305 EtherCAT node address setting.

Device ID	Setting range
Pr.1305	1 to 65535 ("0" is set when Device ID is not set.)

2.13.3 EtherCAT state machine (ESM)

- Definition

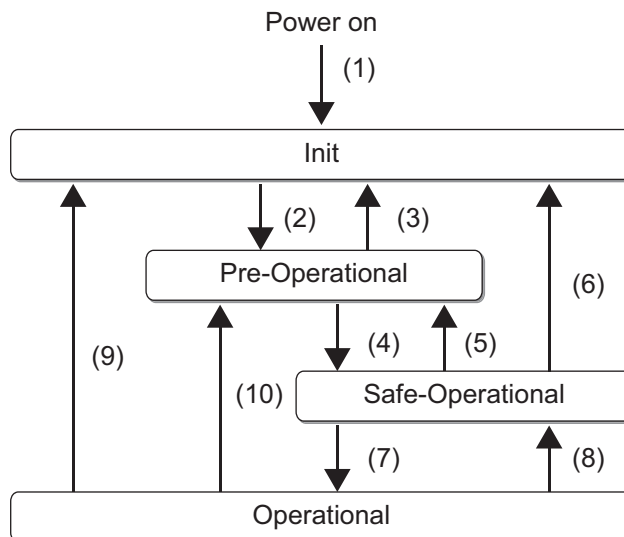

Status	Description
Init (INIT)	Initialization of communication
Pre-Operational (PREOP)	SDO communication enabled
Safe-Operational (SAFEOP)	SDO communication enabled Only TxPDO (inverter to master) transmission enabled for PDO communication
Operational (OP)	SDO communication and PDO communication enabled Writing using SDO communication is not available to the object mapped in RxPDO (master to inverter).

- Transition No.

Transition No.	Description
(1)	Power-ON, inverter reset
(2)	SDO communication configuration set by the master Request from the master for transition to the Pre-Operational state
(4)	PDO communication configuration set by the master Request from the master for transition to the Safe-Operational state
(7)	Output of command values from the master started Request from the master for transition to the Operational state
(5) (10)	Request from the master for transition to the Pre-Operational state
(8)	Request from the master for transition to the Safe-Operational state
(3) (6) (9)	Request from the master for transition to the Init state

2.13.4 PDO (Process Data Object) communication

PDO communication enables cyclic data transmission between the master and the inverter for the command data sent from the master (RxPDO) and the status data sent from the inverter (TxPDO). Users can select communication data.

◆ PDO assign object

- Set the PDO mapping object to be used in the PDO assign object (Index H1C12 or H1C13).
- To change the PDO assign object settings, follow the following procedure in the Pre-Operational state.

1. Write "0" in Sub index H00.
2. Write the index number of the PDO mapping object to be used in Sub index H01.
3. Write "1" in Sub index H00.

◆ PDO mapping object

- The content of the data to be sent or received is set in a PDO mapping object. Index H1600 and H1620 are used for RxPDO and Index H1A00 and H1A20 are used for TxPDO.
- The mapping content of Index H1600 and H1A00 can be changed using inverter parameters.
- The mapping content of Index H1620 and H1A20 can be changed using SDO communication. To change the settings, follow the following procedure in the Pre-Operational state.

1. Write "0" in Sub index H00.
2. Write the setting values in Sub index H01 to H0n (n: number of data).
3. Write the number of data (n) in Sub index H00.

■ Index H1600 (1st receive PDO mapping)

Sub index	Name	Mapping content (fixed)	Data length (bit)
H01	Mapped Object 001	Index H6040 (controlword)	16
H02	Mapped Object 002	Index H5FFE, Sub index H01 (Index: Pr.1320, Sub index: Pr.1389 (low))	32
H03	Mapped Object 003	Index H5FFE, Sub index H02 (Index: Pr.1321, Sub index: Pr.1389 (high))	32
H04	Mapped Object 004	Index H5FFE, Sub index H03 (Index: Pr.1322, Sub index: Pr.1390 (low))	32
H05	Mapped Object 005	Index H5FFE, Sub index H04 (Index: Pr.1323, Sub index: Pr.1390 (high))	32
H06	Mapped Object 006	Index H5FFE, Sub index H05 (Index: Pr.1324, Sub index: Pr.1391 (low))	32
H07	Mapped Object 007	Index H5FFE, Sub index H06 (Index: Pr.1325, Sub index: Pr.1391 (high))	32
H08	Mapped Object 008	Index H5FFE, Sub index H07 (Index: Pr.1326, Sub index: Pr.1392 (low))	32
H09	Mapped Object 009	Index H5FFE, Sub index H08 (Index: Pr.1327, Sub index: Pr.1392 (high))	32
H0A	Mapped Object 010	Index H5FFE, Sub index H09 (Index: Pr.1328, Sub index: Pr.1393 (low))	32
H0B	Mapped Object 011	Index H5FFE, Sub index H0A (Index: Pr.1329, Sub index: Pr.1393 (high))	32

NOTE

- If the same index number is specified in two or more of **Pr.1320 to Pr.1329**, the number set in the parameter with the smallest parameter number is valid. The same number set in the other parameters is regarded as "9999".
- When a nonexistent index number or "9999" is set in **Pr.1320 to Pr.1329**, the data is regarded as H0.

■ Index H1620 (33rd receive PDO mapping)

Sub index	Name	Mapping content (initial value)	Data length (bit)	Remarks
H01	Mapped Object 001	Index H6040 (controlword) (fixed)	16	Unchangeable
H02	Mapped Object 002	Index H6042 (vl target velocity)	16	The number of data sets is changeable. (Specify the number in Sub index H00.)
H03	Mapped Object 003	No function	Determined by the mapping content	
H04	Mapped Object 004			
H05	Mapped Object 005			
H06	Mapped Object 006			
H07	Mapped Object 007			
H08	Mapped Object 008			
H09	Mapped Object 009			
H0A	Mapped Object 010			
H0B	Mapped Object 011			

■ Index H1A00 (1st transmit PDO mapping)

Sub index	Name	Mapping content (fixed)	Data length (bit)
H01	Mapped Object 001	Index H6041 (statusword)	16
H02	Mapped Object 002	Index H5FFF, Sub index H01 (Index: Pr.1330, Sub index: Pr.1394 (low))	32
H03	Mapped Object 003	Index H5FFF, Sub index H02 (Index: Pr.1331, Sub index: Pr.1394 (high))	32
H04	Mapped Object 004	Index H5FFF, Sub index H03 (Index: Pr.1332, Sub index: Pr.1395 (low))	32
H05	Mapped Object 005	Index H5FFF, Sub index H04 (Index: Pr.1333, Sub index: Pr.1395 (high))	32
H06	Mapped Object 006	Index H5FFF, Sub index H05 (Index: Pr.1334, Sub index: Pr.1396 (low))	32
H07	Mapped Object 007	Index H5FFF, Sub index H06 (Index: Pr.1335, Sub index: Pr.1396 (high))	32
H08	Mapped Object 008	Index H5FFF, Sub index H07 (Index: Pr.1336, Sub index: Pr.1397 (low))	32
H09	Mapped Object 009	Index H5FFF, Sub index H08 (Index: Pr.1337, Sub index: Pr.1397 (high))	32
H0A	Mapped Object 010	Index H5FFF, Sub index H09 (Index: Pr.1338, Sub index: Pr.1398 (low))	32
H0B	Mapped Object 011	Index H5FFF, Sub index H0A (Index: Pr.1339, Sub index: Pr.1398 (high))	32
H0C	Mapped Object 012	Index H5FFF, Sub index H0B (Index: Pr.1340, Sub index: 0x00)	32
H0D	Mapped Object 013	Index H5FFF, Sub index H0C (Index: Pr.1341, Sub index: 0x00)	32
H0E	Mapped Object 014	Index H5FFF, Sub index H0D (Index: Pr.1342, Sub index: 0x00)	32
H0F	Mapped Object 015	Index H5FFF, Sub index H0E (Index: Pr.1343, Sub index: 0x00)	32

NOTE

- When a nonexistent index number or "9999" is set in **Pr.1330 to Pr.1343**, the data is regarded as H0.

■ Index H1A20 (33rd transmit PDO mapping)

Sub index	Name	Mapping content (initial value)	Data length (bit)	Remarks
H01	Mapped Object 001	Index H6041 (statusword) (fixed)	16	Unchangeable
H02	Mapped Object 002	Index H6043 (vl velocity demand)	16	
H03	Mapped Object 003	No function	Determined by the mapping content	
H04	Mapped Object 004			
H05	Mapped Object 005			
H06	Mapped Object 006			
H07	Mapped Object 007			
H08	Mapped Object 008			
H09	Mapped Object 009			
H0A	Mapped Object 010			
H0B	Mapped Object 011			
H0C	Mapped Object 012			
H0D	Mapped Object 013			
H0E	Mapped Object 014			
H0F	Mapped Object 015			

2.13.5 CoE object dictionary

Index	Description	Refer to page
H1000 to H1FFF	CoE (CAN application protocol over EtherCAT) communication area	page 215
H3000 to H5FFF	Manufacturer specific area	page 211
H6000 to HFFFF	Profile area (CiA402 drive profile)	page 202

◆ Profile area (CiA402 drive profile)

Index	Sub index	Name	Description	Read/write	Data type
H603F (24639)	H00	Error code	Error number The error code of the latest fault that occurred after power-ON or an inverter reset is returned. When no fault occurs, no error is returned. When the fault history is cleared during occurrence of a fault, no error is returned. The upper eight bits are fixed to FF, and the lower eight bits represent the error code. (HFFXX: "XX" represents the error code.) (For details on error codes, refer to the list of fault displays in the Instruction Manual (Maintenance).)	Read	Unsigned16
H6040 (24640)	H00	Controlword	Refer to page 209 .	Read/write	Unsigned16
H6041 (24641)	H00	Statusword	Refer to page 210 .	Read	Unsigned16
H6042 (24642)	H00	vl target velocity	Set speed (r/min) ^{*2*4} Set the set frequency in r/min. Monitoring range: -32768 (H8000) to 32767 (H7FFF) When Pr.81 = "9999", the number of motor poles is regarded as 4. Do not change the settings of this index and index H60FF at the same time.	Read/write	Integer16
H6043 (24643)	H00	vl velocity demand	Output frequency (r/min) ^{*2} The output frequency is read in r/min. Monitoring range: -32768 (H8000) to 32767 (H7FFF) When Pr.81 = "9999", the number of motor poles is regarded as 4.	Read	Integer16
H6044 (24644)	H00	vl velocity actual value	Operation speed (r/min) ^{*2} The operation speed is read in r/min. Monitoring range: -32768 (H8000) to 32767 (H7FFF) When Pr.81 = "9999", the number of motor poles is regarded as 4.	Read	Integer16

Index	Sub index	Name	Description	Read/write	Data type
H6046 (24646)	—	vl velocity min max amount	Minimum/maximum speed (r/min)	—	—
	H00	Highest sub-index supported	Maximum value of subindex: H02 (fixed)	Read	Unsigned8
	H01	vl velocity min amount	Minimum speed (r/min) ^{*2*3} Set Pr.2 Minimum frequency in r/min. Setting range: 0 to 120 Hz	Read/write	Unsigned32
	H02	vl velocity max amount	Maximum speed (r/min) ^{*2*3} Set Pr.18 High speed maximum frequency in r/min. Setting range: 0 to 590 Hz Do not change the settings of this index and index H607F at the same time.	Read/write	Unsigned32
H6048 (24648)	—	vl velocity acceleration	Acceleration vl velocity acceleration = Delta speed/Delta time	—	—
	H00	Highest sub-index supported	Maximum value of subindex: H02 (fixed)	Read	Unsigned8
	H01	Delta speed	Reference speed (r/min) ^{*2*3} Set Pr.20 Acceleration/deceleration reference frequency in r/min. Setting range: 1 to 590 Hz	Read/write	Unsigned32
	H02	Delta time	Acceleration time (s) ^{*3} Set Pr.7 Acceleration time . Setting range: 0 to 3600 s (Example: To accelerate to 1500 r/min for 3.7 seconds, set sub index H01 to 15000 r/min and set sub index H02 to 37 seconds.) Do not change the settings of this index and index H6083 at the same time.	Read/write	Unsigned16
H6049 (24649)	—	vl velocity deceleration	Deceleration vl velocity deceleration = Delta speed/Delta time	—	—
	H00	Highest sub-index supported	Maximum value of subindex: H02 (fixed)	Read	Unsigned8
	H01	Delta speed	Reference speed (r/min) ^{*2*3} Set Pr.20 Acceleration/deceleration reference frequency in r/min. Setting range: 1 to 590 Hz	Read/write	Unsigned32
	H02	Delta time	Deceleration time (s) ^{*3} Set Pr.8 Deceleration time . Setting range: 0 to 3600 s (Example: To decelerate from 1500 r/min for 3.7 seconds, set sub index H01 to 15000 r/min and set sub index H02 to 37 seconds.) Do not change the settings of this index and index H6084 at the same time.	Read/write	Unsigned16
H604A (24650)	—	vl velocity quick stop	Quick stop	—	—
	H00	Highest sub-index supported	Maximum value of subindex: H02 (fixed)	Read	Unsigned8
	H01	Delta speed	Reference speed (r/min) ^{*2} Set Pr.20 Acceleration/deceleration reference frequency in r/min. Setting range: 1 to 590 Hz	Read/write	Unsigned32
	H02	Delta time	Deceleration time (s) Set Pr.1103 Deceleration time at emergency stop . Setting range: 0 to 3600 s (Example: To decelerate from 1500 r/min for 3.7 seconds, set sub index H01 to 15000 r/min and set sub index H02 to 37 seconds.)	Read/write	Unsigned16
H605A (24666) ^{*1}	H00	Quick stop option code	Quick stop option code: H0002 (fixed)	Read/write	Integer16
H6060 (24672)	H00	Modes of operation	Control mode: -1 (vendor specific operation mode) (fixed)	Read/write	Integer8
H6061 (24673)	H00	Modes of operation display	Current control mode: -1 (vendor specific operation mode) (fixed)	Read	Integer8
H6062 (24674)	H00	Position demand value	Position command (pulse) The position command before the electronic gear operation is read.	Read	Integer32
H6063 (24675)	H00	Position actual internal value	Current position (pulse) The current position after the electronic gear operation is read.	Read	Integer32

Index	Sub index	Name	Description	Read/write	Data type
H6064 (24676)	H00	Position actual value	Current position (pulse) The current position before the electronic gear operation is read.	Read	Integer32
H6065 (24677)	H00	Following error window	Droop pulse error judgment value (pulse) Initial value: 40000 (H9C40) Setting range: H00000000 to HFFFFFFF	Read/write	Unsigned32
H6066 (24678)	H00	Following error time out	Droop pulse error judgment time: H0000 (fixed)	Read/write	Unsigned16
H6067 (24679)	H00	Position window	In-position judgment value (pulse) Set the in-position width. Initial value: 100 (H64) Setting range: H00000000 to HFFFFFFF	Read/write	Unsigned32
H6068 (24680)	H00	Position window time	In-position judgment time: H0000 (fixed)	Read/write	Unsigned16
H6071 (24689)	H00	Target torque	Target torque (%) Set Pr.805 Torque command value (RAM) . Setting range: 600% to 1400% When the value is set in 0.1 increments, the first decimal place is rounded off.	Read/write	Integer16
H6074 (24692)	H00	Torque demand	Torque demand value (%) The torque command is read.	Read	Integer16
H6077 (24695)	H00	Torque actual value	Torque actual value (%) The motor torque is read.	Read	Integer16
H607A (24698)	H00	Target position	Target position (pulse) Set the target position in the direct command mode. Initial value: 0 Setting range: -2147483647 to 2147483647 (For the direct command mode, refer to the FR-E800 Instruction Manual (Function).)	Read/write	Integer32
H607E (24702)	H00	Polarity	Direction of rotation: 0 or 128 Bit 0 to 6: 0 Bit 7: Direction of rotation set by the controlword during position control (0: Forward, 1: Reverse)	Read/write	Unsigned8
H607F (24703)	H00	Max profile velocity	Maximum profile speed (r/min) ^{*2*3} Set Pr.18 High speed maximum frequency in r/min. Setting range: 0 to 590 Hz Do not change the settings of this index and index H6046, sub index H02 at the same time.	Read/write	Unsigned32
H6081 (24705)	H00	Profile velocity	Profile speed (r/min) Set the maximum speed in the direct command mode. Initial value: 0 Setting range: 0 to (120 × 590 Hz / Pr.81) (For the direct command mode, refer to the FR-E800 Instruction Manual (Function).)	Read/write	Unsigned32
H6083 (24707)	H00	Profile acceleration	Acceleration time constant (ms) <Position control> Set the acceleration time in the direct command mode. Initial value: 5000 Setting range: 10 to 360000 The last digit is rounded off. (For example, 1358 ms becomes 1350 ms.) (For the direct command mode, refer to the FR-E800 Instruction Manual (Function).) <Other than position control> Set Pr.7 Acceleration time in ms. Setting range: 0 to 3600 s The last two digits are rounded off when Pr.21 Acceleration/ deceleration time increments = "0", and the last digit is rounded off when Pr.21 = "1". Do not change the settings of this index and index H6048, sub index H02 at the same time.	Read/write	Unsigned32

Index	Sub index	Name	Description	Read/write	Data type
H6084 (24708)	H00	Profile deceleration	Deceleration time constant (ms) <Position control> Set the deceleration time in the direct command mode. Initial value: 5000 Setting range: 10 to 360000 The last digit is rounded off. (For example, 1358 ms becomes 1350 ms.) (For the direct command mode, refer to the FR-E800 Instruction Manual (Function).) <Other than position control> Set Pr.8 Deceleration time in ms. Setting range: 0 to 3600 s The last two digits are rounded off when Pr.21 Acceleration/ deceleration time increments = "0", and the last digit is rounded off when Pr.21 = "1". Do not change the settings of this index and index H6049, sub index H02 at the same time.	Read/write	Unsigned32
H6085 (24709)	H00	Quick stop deceleration	Deceleration time constant (QuickStop) (ms) ^{*3} <Position control> Set Pr.464 Digital position control sudden stop deceleration time in ms. Setting range: 0.01 to 360 s The last digit is rounded off. (For example, 1358 ms becomes 1350 ms.) <Other than position control> Set Pr.1103 Deceleration time at emergency stop in ms. Setting range: 0 to 3600 s The last two digits are rounded off when Pr.21 Acceleration/ deceleration time increments = "0", and the last digit is rounded off when Pr.21 = "1".	Read/write	Unsigned32
H608F (24719)	—	Position encoder resolution	Encoder resolution (machine side / motor side)	—	—
	H00	Highest sub-index supported	Maximum value of subindex: H02 (fixed)	Read	Unsigned8
	H01	Encoder increments	Encoder resolution Set Pr.369 Number of encoder pulses . Setting range: 2 to 4096	Read/write	Unsigned32
	H02	Motor revolutions	Motor speed (rev): H00000001 (fixed)	Read/write	Unsigned32
H6091 (24721)	—	Gear ratio	Gear ratio	—	—
	H00	Highest sub-index supported	Maximum value of subindex: H02 (fixed)	Read	Unsigned8
	H01	Motor revolutions	Motor shaft revolutions ^{*3} Set Pr.420 Command pulse scaling factor numerator (electronic gear numerator) . Setting range: 1 to 32767	Read/write	Unsigned32
	H02	Shaft revolutions	Drive shaft revolutions ^{*3} Set Pr.421 Command pulse multiplication denominator (electronic gear denominator) . Setting range: 1 to 32767	Read/write	Unsigned32
H6098 (24728)	H00	Homing method	Home position return method Set the home position return method in the direct command mode. ^{*5} (For the direct command mode and the home position return method, refer to the FR-E800 Instruction Manual (Function).)	Read/write	Integer8
H6099 (24729)	—	Homing speeds	Home position return speed	—	—
	H00	Highest sub-index supported	Maximum value of subindex: H02 (fixed)	Read	Unsigned8
	H01	Speed during search for switch	Motor speed during home position returning (r/min) Set the home position return speed in the direct command mode. Initial value: 120 × 2 Hz / Pr.81 Setting range: 0 to (120 × 400 Hz / Pr.81) (For the direct command mode, refer to the FR-E800 Instruction Manual (Function).)	Read/write	Unsigned32
	H02	Speed during search for zero	H00000000 (fixed)	Read/write	Unsigned32

Index	Sub index	Name	Description	Read/write	Data type
H609A (24730)	H00	Homing acceleration	Home position return acceleration/deceleration time (ms) Set the home position return acceleration/deceleration time in the direct command mode. Initial value: 5000 Setting range: 10 to 360000 The last digit is rounded off. (For example, 1358 ms becomes 1350 ms.) (For the direct command mode, refer to the FR-E800 Instruction Manual (Function).)	Read/write	Unsigned32
H60F4 (24820)	H00	Following error actual value	Droop pulse (pulse) The droop pulse before the electronic gear operation is read.	Read	Integer32
H60FA (24826)	H00	Control effort	Speed command after position loop ^{*2} The ideal speed command is read.	Read	Integer32
H60FC (24828)	H00	Position demand internal value	Position command (pulse) The position command after the electronic gear operation is read.	Read	Integer32
H60FF (24831)	H00	Target velocity	Set speed (r/min) ^{*2*4} Set the set frequency in r/min. Monitoring range: -32768 (H8000) to 32767 (H7FFF) When Pr.81 = "9999", the number of motor poles is regarded as 4. For writing the value after the unit switchover using Pr.53 , the lower 24 bits of the data are valid and the upper 8 bits are ignored. Do not change the settings of this index and index H6042 at the same time.	Read/write	Integer32
H6502 (25858)	H00	Supported drive modes	Supported control mode: H00010000 (vendor specific operation mode)	Read	Unsigned32
H67FF (26623) ^{*1}	H00	Single device type	Device type Bit 0 to 15 Device Profile Number: H0192 (402: Drive Profile) Bit 16 to 23 Additional Information (Type): H01 (Frequency Converter: inverter) Bit 24 to 31 Additional Information (mode bits): H00	Read	Unsigned32

*1 Not available for PDO communication.

*2 The value is displayed and set in r/min regardless of the settings in **Pr.53**.

The frequency is converted to the rotation speed for reading, and the setting value is converted to the frequency for writing.

*3 When parameter write is performed, data are written to RAM for PDO communication. Writing to EEPROM or RAM is selected according to the setting in **Pr.342 Communication EEPROM write selection** for SDO communication.

*4 Writing is not restricted by the **Pr.18 and Pr.2** settings.

*5 The following table shows home position return methods corresponding to the Index H6098 setting values.

H6098 setting	Home position return method
-3	Data set type
-4	Stopper type (home position return direction: position pulse increasing direction)
-5 (initial value)	Ignoring the home position (servo ON position as the home position)
-7	Count type with front end reference (home position return direction: position pulse increasing direction)
-36	Stopper type (home position return direction: position pulse decreasing direction)
-39	Count type with front end reference (home position return direction: position pulse decreasing direction)
-65	Stopper type (home position return direction: start command direction)
-66	Count type with front end reference (home position return direction: start command direction)

NOTE

- The command interface in the Network operation mode is determined by the **Pr.550 NET mode operation command source selection** setting. (Refer to the FR-E800 Instruction Manual (Function).)
- When the data is read, the value is displayed with a sign regardless of the **Pr.290 Monitor negative output selection** setting.

■ Power drive system (PDS) state transition

After PDO communication is established (ESM: Operational state), the master controls the operating status by sending a command using the controlword. When the "Not ready to switch on" state immediately after a power-ON or inverter reset transits to the "Operation enabled" state, the inverter is ready for operation. Writing to controlword using SDO communication will not be reflected.

- Definition

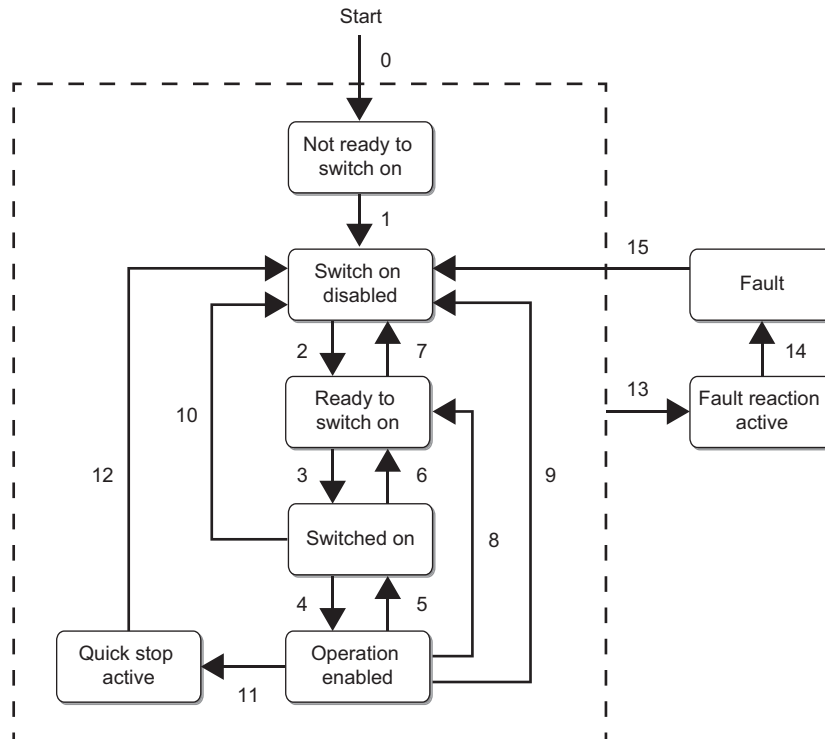

Name	Status	Inverter operation ^{*1}	
		Position control	Other than position control
Not ready to switch on	During stop (initialization in progress)	Output shutoff (RY signal OFF)	
Switch on disabled	During stop (initial status)	Output shutoff (RY signal OFF)	
Ready to switch on	During stop (ready)	Output shutoff (RY signal OFF)	
Switched on	During stop (standby)	Output shutoff canceled (RY signal ON) ^{*2}	
Operation enabled	During operation (enabled)	Same operation as in servo-ON (LX signal ON) status	<ul style="list-style-type: none"> • Enable operation command received (Same operation as when the start command is turned ON^{*3}) • Disable operation command received (Same operation as when the start command is turned OFF)
Quick stop active	During emergency stop	Sudden stop function activated (same operation as when the X87 signal is turned ON (normally input))	Emergency stop function activated (same operation as when the X92 signal is turned ON)
Fault reaction active	Fault detection enabled	— (State transition to "Fault")	
Fault	Active fault situation	Output shutoff (RY signal OFF)	

*1 During EtherCAT communication, the servo ON/OFF status or the start command is controlled by the PDS state transition.

*2 When the output is shut off by the MRS signal or other signal, the RY signal remains OFF.

*3 The start command direction depends on the sign of the value of vl target velocity (H6042) or Target velocity (H60FF).

NOTE

- When all the following conditions are satisfied, the control using the controlword and the state transition is enabled.
 - NET operation mode
 - The Ethernet connector is the command interface enabled in the NET operation mode (Pr.550).
 - Pr.338 Communication operation command source = "0"
- The main circuit capacitor's life cannot be measured when the control using the controlword is enabled. (For the measurement of the main circuit capacitor's life, refer to the Instruction Manual (Function).)

• Transition No.

Transition No.	Controlword	Other than controlword
0	—	Power-ON, inverter reset
1	—	Automatic transition after initialization
2	Shutdown command	—
3	Switch on command	—
4	Enable operation command (transition disabled when the RY signal is OFF)	—
5	Disable operation command ^{*1} Transition after the inverter is stopped (transition disabled during DC injection brake operation or pre-excitation)	Transition enabled when the RY signal turns OFF ^{*1}
6	Shutdown command	—
7	Disable voltage or Quick stop command	^{*3}
8	Shutdown command ^{*1}	—
9	Disable voltage command ^{*1}	^{*3}
10	Disable voltage or Quick stop command	^{*3}
11	Quick stop command ^{*2}	—
12	Disable voltage command ^{*1}	Automatic transition after an emergency stop ^{*3} • Position control Automatic transition after the PBSY signal turns OFF • Other than position control Automatic transition after the inverter is stopped (transition disabled during DC injection brake operation or pre-excitation)
13	—	Fault detected
14	—	Automatic transition ^{*1}
15	Fault reset command from the master The protective function is reset. ^{*4}	^{*3}

*1 The servo ON (LX signal ON) state (during position control) or the start command ON state (during control other than position control) that is activated by inputting the command will be canceled.

*2 When the command is not used and the X87 or X92 signal is assigned for an emergency stop, transition to the "Quick stop active" state is disabled.

*3 When any one of the following conditions is not satisfied, transition to the "Switch on disabled" state will occur.
NET operation mode

The Ethernet connector is the command interface enabled in the NET operation mode (**Pr.550**).

Pr.338 Communication operation command source = "0"

*4 E.16 to E.20, E.PE6, E.PE2, E.CPU, E.SAF, E.CMB, E.1, E.5 to E.7, and E.13 are not reset. In this case, take an appropriate corrective action first, and reset them by power reset or inverter reset.

■ Controlword (H6040)

- Position control

After home position return is completed and bit 4 is changed from 1 to 0, positioning operation starts. However, bit 4 operation is not required when the home position return method is ignoring the home position (servo ON position as the home position), or the roll feed mode, current position retention function, or JOG operation is used.

Bit	Name	Home position return	Positioning
0	switch on (so)	Refer to page 209 .	
1	enable voltage (ev)		
2	quick stop (qs)		
3	enable operation (eo)		
4	HOS (oms)	Home position return starts when the bit is changed from 0 to 1.* ¹ 0: Do not start homing procedure 1: Start or continue homing procedure	—
	new set-point (oms)	—	Position data is obtained and positioning starts when the bit is changed from 0 to 1.
5	Not used		
6	abs/rel (oms)	—	0: Absolute position command 1: Incremental position command
7	fault reset (fr)	Refer to page 209 .	
8 to 15	Not used		

*1 To perform home position return again, change the "Switched on" state to the "Operation enabled" state once. (Refer to [page 211](#).)

- Other than position control

Bit	Name	Speed control and torque control
0	switch on (so)	Refer to page 209 .
1	enable voltage (ev)	
2	quick stop (qs)	
3	enable operation (eo)	
4 to 6	Not used	
7	fault reset (fr)	Refer to page 209 .
8 to 15	Not used	

- Transition command

Command	Bit 7	Bit 3	Bit 2	Bit 1	Bit 0
	fr	eo	qs	ev	so
Shutdown	0	—	1	1	0
Switch on	0	0	1	1	1
Disable voltage	0	—	—	0	—
Quick stop	0	—	0	1	—
Disable operation	0	0	1	1	1
Enable operation	0	1	1	1	1
Fault reset	0 to 1	—	—	—	—

—: Not used

State transition shown in the following table is also available.

Current state	Command	State after transition
Switch on disabled	Switch on	Switched on
Switch on disabled	Enable operation	Operation enabled
Ready to switch on	Enable operation	Operation enabled

- Status during emergency drive operation

Emergency drive operating status	State after transition
During commercial power supply operation during emergency drive	Switch on disabled
When a critical fault occurs	Fault reaction active to Fault
Others	Operation enabled

■ Statusword (H6041)

- Position control

After home position return is completed and bit 4 of controlword is changed from 1 to 0, positioning operation starts. However, bit 4 operation is not required when the home position return method is ignoring the home position (servo ON position as the home position), or the roll feed mode, current position retention function, or JOG operation is used.

Bit	Name	Home position return	Positioning
0	ready to switch on (rtso)	Refer to page 211 .	
1	switched on (so)		
2	operation enabled (oe)		
3	Fault (f)		
4	Not used		
5	quick stop (qs)	Refer to page 211 .	
6	switch on disabled (sod)		
7	warning (w)	0: Without warning or alarm 1: With warning or alarm	
8	Not used		
9	remote (rm)	0: Control using the controlword disabled 1: Control using the controlword enabled* ¹	
10	hm (tr)* ²	<ul style="list-style-type: none"> • Without home position return failure (ZA signal OFF) 0: PBSY signal ON 1: PBSY signal OFF • With home position return failure (ZA signal ON) 0: Ideal speed command other than 0 1: Ideal speed command 0 	—
	target reached (tr)	—	0: Target position not reached 1: Target position reached The bit is changed to 1 when the difference (absolute value) of the target position (H607A) and the position actual value (H6064) is equal to or less than the position window (H6067) setting for the time set in the position window time (H6068).
11	internal limit active	0: Forward or reverse stroke end not reached (LP signal OFF) 1: Forward or reverse stroke end reached (LP signal ON)	
12	hm (oms)* ²	0: Home position return not completed (ZP signal OFF) 1: Home position return completed (ZP signal ON)	—
13	hm (oms)* ²	0: Without home position return failure (ZA signal OFF) 1: With home position return failure (ZA signal ON)	—
	Following error (oms)	—	0: No following error 1: Following error The bit is changed to 1 when the difference (absolute value) of the position demand value (H6062) and the position actual value (H6064) exceeds the following error window (H6065) setting for the time set in the following error time out (H6066).
14, 15	Not used		

- *1 When all the following conditions are satisfied, the control using the controlword and the state transition is enabled.
NET operation mode
The Ethernet connector is the command interface enabled in the NET operation mode (Pr.550).
Pr.338 Communication operation command source = "0"
- *2 Combination of hm (bit 10, 12, and 13)

Bit 13	Bit 12	Bit 10	Description
0	0	0	During home position return operation
0	0	1	Before home position return
0	1	1	Home position return completed normally
1	0	1	A home position return failure occurs and the ideal speed command is 0.

- Other than position control

Bit	Name	Speed control and torque control
0	ready to switch on (rtso)	Refer to page 211 .
1	switched on (so)	
2	operation enabled (oe)	
3	Fault (f)	
4	Not used	
5	quick stop (qs)	Refer to page 211 .
6	switch on disabled (sod)	
7	warning (w)	0: Without warning or alarm 1: With warning or alarm
8	Not used	
9	remote (rm)	0: Control using the controlword disabled 1: Control using the controlword enabled ^{*1}
10 to 15	Not used	

- *1 When all the following conditions are satisfied, the control using the controlword and the state transition is enabled.
NET operation mode
The Ethernet connector is the command interface enabled in the NET operation mode (Pr.550).
Pr.338 Communication operation command source = "0"

- Transition status

Status	Bit 6	Bit 5	Bit 3	Bit 2	Bit 1	Bit 0
	sod	qs	f	oe	so	rtso
Not ready to switch on	0	—	0	0	0	0
Switch on disabled	1	—	0	0	0	0
Ready to switch on	0	1	0	0	0	1
Switched on	0	1	0	0	1	1
Operation enabled	0	1	0	1	1	1
Quick stop active	0	0	0	1	1	1
Fault reaction active	0	—	1	1	1	1
Fault	0	—	1	0	0	0

—: Not used

◆ Manufacturer specific area

■ Inverter parameters

Index	Sub index	Name	Remarks	Read/write	Size
12288 to 13787 (H3000 to H35DB)	H00 to H02	Parameter #nnnn (nnnn: inverter parameter number (decimal))	The inverter parameter number (decimal) + 12288 (H3000) is the index number.	Read/write	16 bits

- Calibration parameter

Index	Sub index	Name	Description	Read/write	Size
13188 (H3384)	H00	Highest sub-index supported	—	Read	8 bits
	H01	Data	C0 (Pr.900)	Read/write	16 bits
	H02	Sub Data	—	Read/write	16 bits
13189 (H3385)	H00	Highest sub-index supported	—	Read	8 bits
	H01	Data	C1 (Pr.901)	Read/write	16 bits
	H02	Sub Data	—	Read/write	16 bits
13190 (H3386)	H00	Highest sub-index supported	—	Read	8 bits
	H01	Data	C2 (Pr.902)	Read/write	16 bits
	H02	Sub Data	C3 (Pr.902)	Read/write	16 bits
13191 (H3387)	H00	Highest sub-index supported	—	Read	8 bits
	H01	Data	125 (Pr.903)	Read/write	16 bits
	H02	Sub Data	C4 (Pr.903)	Read/write	16 bits
13192 (H3388)	H00	Highest sub-index supported	—	Read	8 bits
	H01	Data	C5 (Pr.904)	Read/write	16 bits
	H02	Sub Data	C6 (Pr.904)	Read/write	16 bits
13193 (H3389)	H00	Highest sub-index supported	—	Read	8 bits
	H01	Data	126 (Pr.905)	Read/write	16 bits
	H02	Sub Data	C7 (Pr.905)	Read/write	16 bits
13205 (H3395)* ¹	H00	Highest sub-index supported	—	Read	8 bits
	H01	Data	C12 (Pr.917)	Read/write	16 bits
	H02	Sub Data	C13 (Pr.917)	Read/write	16 bits
13206 (H3396)* ¹	H00	Highest sub-index supported	—	Read	8 bits
	H01	Data	C14 (Pr.918)	Read/write	16 bits
	H02	Sub Data	C15 (Pr.918)	Read/write	16 bits
13207 (H3397)* ¹	H00	Highest sub-index supported	—	Read	8 bits
	H01	Data	C16 (Pr.919)	Read/write	16 bits
	H02	Sub Data	C17 (Pr.919)	Read/write	16 bits
13208 (H3398)* ¹	H00	Highest sub-index supported	—	Read	8 bits
	H01	Data	C18 (Pr.920)	Read/write	16 bits
	H02	Sub Data	C19 (Pr.920)	Read/write	16 bits
13220 (H33A4)	H00	Highest sub-index supported	—	Read	8 bits
	H01	Data	C38 (Pr.932)	Read/write	16 bits
	H02	Sub Data	C39 (Pr.932)	Read/write	16 bits
13221 (H33A5)	H00	Highest sub-index supported	—	Read	8 bits
	H01	Data	C40 (Pr.933)	Read/write	16 bits
	H02	Sub Data	C41 (Pr.933)	Read/write	16 bits
13222 (H33A6)	H00	Highest sub-index supported	—	Read	8 bits
	H01	Data	C42 (Pr.934)	Read/write	16 bits
	H02	Sub Data	C43 (Pr.934)	Read/write	16 bits
13223 (H33A7)	H00	Highest sub-index supported	—	Read	8 bits
	H01	Data	C44 (Pr.935)	Read/write	16 bits
	H02	Sub Data	C45 (Pr.935)	Read/write	16 bits

*1 Available only when the FR-E8AXY is installed.

For the numbers and names of inverter parameters, refer to the parameter list of the Instruction Manual (Function).

NOTE

- Set 65520 (HFFF0) as a parameter value "8888" and 65535 (HFFFF) as "9999".
- When parameter write is performed, data are written to RAM for PDO communication. Writing to EEPROM or RAM is selected according to the setting in **Pr.342 Communication EEPROM write selection** for SDO communication.

■ Monitor data

Index	Sub index	Name	Remarks	Read/write	Size
16384 to 16483 (H4000 to H4063)	H00	Monitor data #nnnn (nnnn: monitor code (decimal))	The monitor code (decimal) + 16384 (H4000) is the index number.	Read	16 bits

For details of the monitor codes and monitor items, refer to the description of **Pr.52** in the Instruction Manual (Function).

NOTE

- Display of negative numbers during monitoring set in **Pr.290 Monitor negative output selection** is disabled.
- The display can be changed from the frequency to rotations per minute (machine speed) using **Pr.53**. When the machine speed is displayed, the value is incremented by one.

■ Inverter control parameter

Index	Sub index	Name	Remarks	Read/write	Size
20482 (H5002)* ¹	H00	Inverter reset	Set H9966 for the written value. The read value is fixed to H0000.	Read/write	16 bits
20483 (H5003)* ¹	H00	Parameter clear	Set H965A for the written value. The read value is fixed to H0000.	Read/write	16 bits
20484 (H5004)* ¹	H00	All parameter clear	Set H99AA for the written value. The read value is fixed to H0000.	Read/write	16 bits
20486 (H5006)* ¹	H00	Parameter clear* ²	Set H5A96 for the written value. The read value is fixed to H0000.	Read/write	16 bits
20487 (H5007)* ¹	H00	All parameter clear* ²	Set HAA99 for the written value. The read value is fixed to H0000.	Read/write	16 bits
20488 (H5008)	H00	Inverter status / control input command (extended)* ³	Refer to page 215 .	Read/write	16 bits
20489 (H5009)	H00	Inverter status / control input command* ³	Refer to page 215 .	Read/write	16 bits
20981 (H51F5)	H00	Fault record 1	Being 2 bytes in length, the data is stored as "H00○○". Refer to the lowest 1 byte for the error code. (For details on error codes, refer to the list of fault displays in the Instruction Manual (Maintenance).) Performing write using 20981 (H51F5) batch-clears the fault history. Set any value as data.	Read/write	16 bits
20982 (H51F6)	H00	Fault record 2		Read	16 bits
20983 (H51F7)	H00	Fault record 3		Read	16 bits
20984 (H51F8)	H00	Fault record 4		Read	16 bits
20985 (H51F9)	H00	Fault record 5		Read	16 bits
20986 (H51FA)	H00	Fault record 6		Read	16 bits
20987 (H51FB)	H00	Fault record 7		Read	16 bits
20988 (H51FC)	H00	Fault record 8		Read	16 bits
20989 (H51FD)	H00	Fault record 9		Read	16 bits
20990 (H51FE)	H00	Fault record 10		Read	16 bits
20992 (H5200)	H00	Safety input status	Refer to page 215 .	Read	16 bits
24574 (H5FFE)	-	RxPDO Parameter Mapping	PDO mapping object for H1600 For writing using PDO communication, the values corresponding to the objects selected using Pr.1320 to Pr.1329 and Pr.1389 to Pr.1393 are written. For reading using SDO communication, the values in the same format as mapping object are read. Bit 16 to 31: Index Bit 8 to 15: Subindex Bit 0 to 7: Object size (bit) Sub index H01: H60420020 (initial value) Sub index H02 to H0A: H00000020 (initial value)	—	—
	H00	Highest sub-index supported		Read	8 bits
	H01	Index: Pr.1320, Sub index: Pr.1389 (low)		Read	32 bits
	H02	Index: Pr.1321, Sub index: Pr.1389 (high)		Read	32 bits
	H03	Index: Pr.1322, Sub index: Pr.1390 (low)		Read	32 bits
	H04	Index: Pr.1323, Sub index: Pr.1390 (high)		Read	32 bits
	H05	Index: Pr.1324, Sub index: Pr.1391 (low)		Read	32 bits
	H06	Index: Pr.1325, Sub index: Pr.1391 (high)		Read	32 bits
	H07	Index: Pr.1326, Sub index: Pr.1392 (low)		Read	32 bits
	H08	Index: Pr.1327, Sub index: Pr.1392 (high)		Read	32 bits
	H09	Index: Pr.1328, Sub index: Pr.1393 (low)		Read	32 bits
H0A	Index: Pr.1329, Sub index: Pr.1393 (high)	Read	32 bits		
24575 (H5FFF)	-	TxPDO Parameter Mapping	PDO mapping object for H1A00 For reading using PDO communication, the values corresponding to the objects selected using Pr.1330 to Pr.1343 and Pr.1394 to Pr.1398 are read. For reading using SDO communication, the values in the same format as mapping object are read. Bit 16 to 31: Index Bit 8 to 15: Subindex Bit 0 to 7: Object size (bit) Sub index H01: H60430020 (initial value) Sub index H02 to H0E: H00000020 (initial value)	—	—
	H00	Highest sub-index supported		Read	8 bits
	H01	Index: Pr.1330, Sub index: Pr.1394 (low)		Read	32 bits
	H02	Index: Pr.1331, Sub index: Pr.1394 (high)		Read	32 bits
	H03	Index: Pr.1332, Sub index: Pr.1395 (low)		Read	32 bits
	H04	Index: Pr.1333, Sub index: Pr.1395 (high)		Read	32 bits
	H05	Index: Pr.1334, Sub index: Pr.1396 (low)		Read	32 bits
	H06	Index: Pr.1335, Sub index: Pr.1396 (high)		Read	32 bits
	H07	Index: Pr.1336, Sub index: Pr.1397 (low)		Read	32 bits
	H08	Index: Pr.1337, Sub index: Pr.1397 (high)		Read	32 bits
	H09	Index: Pr.1338, Sub index: Pr.1398 (low)		Read	32 bits
	H0A	Index: Pr.1339, Sub index: Pr.1398 (high)		Read	32 bits
	H0B	Index: Pr.1340, Sub index: 0x00		Read	32 bits
	H0C	Index: Pr.1341, Sub index: 0x00		Read	32 bits
H0D	Index: Pr.1342, Sub index: 0x00	Read	32 bits		
H0E	Index: Pr.1343, Sub index: 0x00	Read	32 bits		

*1 Not available for PDO communication.

*2 Settings in the communication parameters are not cleared.

*3 The data is written as a control input command for writing.
The data is read as the inverter status for reading.

- Inverter status / control input command, and inverter status / control input command (extended)

Inverter status / control input command			Inverter status / control input command (extended)		
Bit	Definition		Bit	Definition	
	Control input command	Inverter status		Control input command	Inverter status
0	—	RUN (Inverter running) ^{*2}	0	NET X1 (—) ^{*1}	NET Y1 (0) ^{*2}
1	—	During forward rotation	1	NET X2 (—) ^{*1}	NET Y2 (0) ^{*2}
2	—	During reverse rotation	2	NET X3 (—) ^{*1}	NET Y3 (0) ^{*2}
3	RH (High-speed operation command) ^{*1}	Up to frequency	3	NET X4 (—) ^{*1}	NET Y4 (0) ^{*2}
4	RM (Middle-speed operation command) ^{*1}	Overload warning	4	NET X5 (—) ^{*1}	0
5	RL (Low-speed operation command) ^{*1}	0	5	—	0
6	JOG operation selection 2	FU (Output frequency detection) ^{*2}	6	—	0
7	Second function selection	ABC (Fault) ^{*2}	7	—	0
8	Terminal 4 input selection	ABC2 (0) ^{*2}	8	—	0
9	—	Safety monitor output 2	9	—	0
10	MRS (Output stop) ^{*1}	0	10	—	0
11	—	0	11	—	0
12	RES (—) ^{*1}	0	12	—	0
13	—	0	13	—	0
14	—	0	14	—	0
15	—	Fault occurrence	15	—	0

*1 The signal within parentheses () is the initial status. The function changes depending on the setting of **Pr.180 to Pr.189 (Input terminal function selection)**.

For details, refer to the description of **Pr.180 to Pr.189 (Input terminal function selection)** in the Instruction Manual (Function).

The signals assigned to the input terminals may be valid or invalid in the NET operation mode. (Refer to the Instruction Manual (Function).)

*2 The signal within parentheses () is assigned in the initial status. The function changes depending on the setting of **Pr.190 to Pr.197 (Output terminal function selection)**.

For details, refer to the description of **Pr.190 to Pr.197 (Output terminal function selection)** in the Instruction Manual (Function).

- Safety input status

Bit	Definition
0	0: Terminal S1 ON 1: Terminal S1 OFF (output shutoff)
1	0: Terminal S2 ON 1: Terminal S2 OFF (output shutoff)
2 to 15	0

◆ CoE communication area

Index	Sub index	Name	Description	Read/write	Size
H1000	H00	Device Type	Applicable profile information Bit 0 to 15 Device Profile Number: H0192 (402: CiA402) Bit 16 to 23 Additional Information (Type): H01 (Frequency Converter: inverter) Bit 24 to 31: H00	Read	32 bits
H1001	H00	Error Register	Error occurrence status Bit 0: 1: With error, 0: No error Bit 1 to 7: Fixed to 0	Read	8 bits
H1008	H00	Manufacturer Device Name	Inverter model: FR-E800-E	Read	—
H1009	H00	Manufacturer Hardware version	Hardware version	Read	—
H100A	H00	Manufacturer Software version	Software version	Read	—

Index	Sub index	Name	Description	Read/write	Size
H1018	—	Identity Object	—	—	—
	H00	Highest sub-index supported	Maximum value of subindex: H04	Read	8 bits
	H01	Vendor ID	Vendor ID: H00000A1E	Read	32 bits
	H02	Product Code	Product code: H02000301	Read	32 bits
	H03	Revision Number	Revision number	Read	32 bits
	H04	Serial Number	Serial number	Read	32 bits
H1600	—	1st receive PDO mapping	—	—	—
	H00	Highest sub-index supported	Maximum value of subindex: H0B (11) (fixed)	Read	8 bits
	H01	Mapped Object 001	Objects mapped using inverter parameters Bit 16 to 31: Index Bit 8 to 15: Subindex Bit 0 to 7: Object size (bit) Sub index H01: H60400010 (controlword) (fixed) Sub index H02 to H0B: H5FFE0120 to H5FFE0A20 (fixed)	Read	32 bits
	H02	Mapped Object 002		Read	32 bits
	H03	Mapped Object 003		Read	32 bits
	H04	Mapped Object 004		Read	32 bits
	H05	Mapped Object 005		Read	32 bits
	H06	Mapped Object 006		Read	32 bits
	H07	Mapped Object 007		Read	32 bits
	H08	Mapped Object 008		Read	32 bits
	H09	Mapped Object 009		Read	32 bits
	H0A	Mapped Object 010		Read	32 bits
H0B	Mapped Object 011	Read		32 bits	
H1620	—	33rd receive PDO mapping	—	—	—
	H00	Highest sub-index supported	Maximum value of subindex Setting range: H00 to H0B Initial value: H02	Read/write ^{*1}	8 bits
	H01	Mapped Object 001	Objects mapped using SDO communication Bit 16 to 31: Index Bit 8 to 15: Subindex Bit 0 to 7: Object size (bit) Sub index H01: H60400010 (controlword) (fixed) Sub index H02: H60420010 (initial value) Sub index H03 to H0B: H00000000 (initial value) Except for SDO Complete Access, to write data in Sub index H01 to H0B, set "0" in Sub index H00 first.	Read/write ^{*1}	32 bits
	H02	Mapped Object 002		Read/write ^{*1}	32 bits
	H03	Mapped Object 003		Read/write ^{*1}	32 bits
	H04	Mapped Object 004		Read/write ^{*1}	32 bits
	H05	Mapped Object 005		Read/write ^{*1}	32 bits
	H06	Mapped Object 006		Read/write ^{*1}	32 bits
	H07	Mapped Object 007		Read/write ^{*1}	32 bits
	H08	Mapped Object 008		Read/write ^{*1}	32 bits
	H09	Mapped Object 009		Read/write ^{*1}	32 bits
	H0A	Mapped Object 010		Read/write ^{*1}	32 bits
H0B	Mapped Object 011	Read/write ^{*1}		32 bits	
H1A00	—	1st transmit PDO mapping	—	—	—
	H00	Highest sub-index supported	Maximum value of subindex: H0F (15) (fixed)	Read	8 bits
	H01	Mapped Object 001	Objects mapped using inverter parameters Bit 16 to 31: Index Bit 8 to 15: Subindex Bit 0 to 7: Object size (bit) Sub index H01: H60410010 (statusword) (fixed) Sub index H02 to H0F: H5FFF0120 to H5FFF0E20 (fixed)	Read	32 bits
	H02	Mapped Object 002		Read	32 bits
	H03	Mapped Object 003		Read	32 bits
	H04	Mapped Object 004		Read	32 bits
	H05	Mapped Object 005		Read	32 bits
	H06	Mapped Object 006		Read	32 bits
	H07	Mapped Object 007		Read	32 bits
	H08	Mapped Object 008		Read	32 bits
	H09	Mapped Object 009		Read	32 bits
	H0A	Mapped Object 010		Read	32 bits
	H0B	Mapped Object 011		Read	32 bits
	H0C	Mapped Object 012		Read	32 bits
	H0D	Mapped Object 013		Read	32 bits
	H0E	Mapped Object 014		Read	32 bits
H0F	Mapped Object 015	Read		32 bits	

Index	Sub index	Name	Description	Read/write	Size
H1A20	—	33rd transmit PDO mapping	—	—	—
	H00	Highest sub-index supported	Maximum value of subindex Setting range: H00 to H0F Initial value: H02	Read/write ^{*1}	8 bits
	H01	Mapped Object 001	Objects mapped using SDO communication Bit 16 to 31: Index Bit 8 to 15: Subindex Bit 0 to 7: Object size (bit) Sub index H01: H60410010 (statusword) (fixed) Sub index H02: H60430010 (initial value) Sub index H03 to H0F: H00000000 (initial value) Except for SDO Complete Access, to write data in Sub index H01 to H0F, set "0" in Sub index H00 first.	Read/write ^{*1}	32 bits
	H02	Mapped Object 002		Read/write ^{*1}	32 bits
	H03	Mapped Object 003		Read/write ^{*1}	32 bits
	H04	Mapped Object 004		Read/write ^{*1}	32 bits
	H05	Mapped Object 005		Read/write ^{*1}	32 bits
	H06	Mapped Object 006		Read/write ^{*1}	32 bits
	H07	Mapped Object 007		Read/write ^{*1}	32 bits
	H08	Mapped Object 008		Read/write ^{*1}	32 bits
	H09	Mapped Object 009		Read/write ^{*1}	32 bits
	H0A	Mapped Object 010		Read/write ^{*1}	32 bits
	H0B	Mapped Object 011		Read/write ^{*1}	32 bits
	H0C	Mapped Object 012		Read/write ^{*1}	32 bits
	H0D	Mapped Object 013		Read/write ^{*1}	32 bits
	H0E	Mapped Object 014		Read/write ^{*1}	32 bits
H0F	Mapped Object 015	Read/write ^{*1}		32 bits	
H1C00	—	Sync Manager Communication Type	—	—	—
	H00	Highest sub-index supported	Maximum value of subindex: H04	Read	8 bits
	H01	Sync Manager 0	Mailbox in (master to inverter)	Read	8 bits
	H02	Sync Manager 1	Mailbox out (inverter to master)	Read	8 bits
	H03	Sync Manager 2	PDO output (master to inverter)	Read	8 bits
	H04	Sync Manager 3	PDO input (inverter to master)	Read	8 bits
H1C12	—	Sync Manager RxPDO Assign	—	—	—
	H00	Highest sub-index supported	Maximum value of subindex Setting range: H00 and H01 Initial value: H01	Read/write ^{*1}	8 bits
	H01	assigned RxPDO 001	PDO mapping object assigned to sync manager 2 (RxPDO) Setting range: H1600 and H1620 Initial value: H1600 Except for SDO Complete Access, to write data in Sub index H01, set "0" in Sub index H00 first.	Read/write ^{*1}	16 bits
H1C13	—	Sync Manager TxPDO Assign	—	—	—
	H00	Highest sub-index supported	Maximum value of subindex Setting range: H00 and H01 Initial value: H01	Read/write ^{*1}	8 bits
	H01	assigned TxPDO 001	PDO mapping object assigned to sync manager 3 (TxPDO) Setting range: H1A00 and H1A20 Initial value: H1A00 Except for SDO Complete Access, to write data in Sub index H01, set "0" in Sub index H00 first.	Read/write ^{*1}	16 bits
H1C32	—	Sync Manager 2 Synchronization	—	—	—
	H00	Highest sub-index supported	Maximum value of subindex: H04	Read	8 bits
	H01	Synchronization Type	Synchronization mode H0000: Free-Run	Read	16 bits
	H04	Synchronization Types supported	Supported synchronization mode H0001: Free-Run is supported.	Read	16 bits

Index	Sub index	Name	Description	Read/write	Size
H1C33	—	Sync Manager 3 Synchronization	—	—	—
	H00	Highest sub-index supported	Maximum value of subindex: H04	Read	8 bits
	H01	Synchronization Type	Synchronization mode H0000: Free-Run	Read	16 bits
	H04	Synchronization Types supported	Supported synchronization mode H0001: Free-Run is supported.	Read	16 bits

*1 Writing is enabled only in the Pre-Operational state.

2.13.6 Operation at fault occurrence

◆ Signal loss detection function

- Signal loss detection is enabled according to the setting in **Pr.1431 Ethernet signal loss detection function selection**. The FR-E800-EPC manufactured in August 2024 or earlier does not support **Pr.1457 Extended setting for Ethernet signal loss detection function selection**. The operation is the same as the one performed when **Pr.1457** = "9999". (Refer to [page 227](#).)

◆ EtherCAT communication fault

- The following table shows operations when a fault is detected during EtherCAT communication.

Fault type	Possible cause	Inverter operation
Status transition fault	The EtherCAT state is not the one requested by the master or the change to the EtherCAT state requested by the master is disabled (for example, after restarting of the master).	The inverter sends the error information to the master and changes the EtherCAT state. When the status is transitioned from Operational to the state other than Operational during inverter operation, the operation is performed according to the setting in Pr.502 Stop mode selection at communication error . (Refer to page 282 .)
Sync manager (SM) change fault	Incorrect setting of SM (for example, SM is disabled).	
PDO communication timeout	Watchdog timeout (due to signal loss, master output not updated, restarting of the master, or other reasons).	

- Watchdog timer

Monitor item	Reset trigger	Overflow time (timeout period)
Process data	Sync Manager 2	100 ms (initial value)

◆ Parameter storage device fault (control circuit board)

- If an error occurs in access to SII (Slave Information Interface) after the firmware update, E.PE occurs. Perform an inverter reset in that case.

2.13.7 Programming example

The following explains a programming example using engineering software.

◆ Forward rotation at 1500 r/min using PDO communication

- Network setting and device examples

Local variable name	Data type	Comment
E001_Output_enable	BOOL	Inverter 1_Output_enable
E001_Input_enable	BOOL	Inverter 1_Input_enable
E001_Rotation	BOOL	Inverter 1_Rotation

Global variable name	PDO mapping	Remarks
E001_Controlword	Controlword	
E001_rPDO2	vl target velocity	Pr.1320 User Defined Cyclic Communication Input 1 Mapping
E001_Statusword	Statusword	
E001_tPDO2	vl velocity demand	Pr.1330 User Defined Cyclic Communication Output 1 Mapping

- Setting the start command and the speed command

When the PDO communication is established, E001_Output_enable and E001_Input_enable turn ON.
 The inverter transfers to "Switched on" state by the PDS state transition.

Set the speed command to 1500 r/min (when **Pr.81 Number of motor poles** is set to 4 poles (initial value)).
 Speed command: vl target velocity (H6042) = 1500 r/min

Turning ON E001_Rotation turns ON Enable operation to start forward rotation at 1500 r/min.
 Turning OFF E001_Rotation stops operation.
 Set a negative value for vl target velocity for reverse rotation.

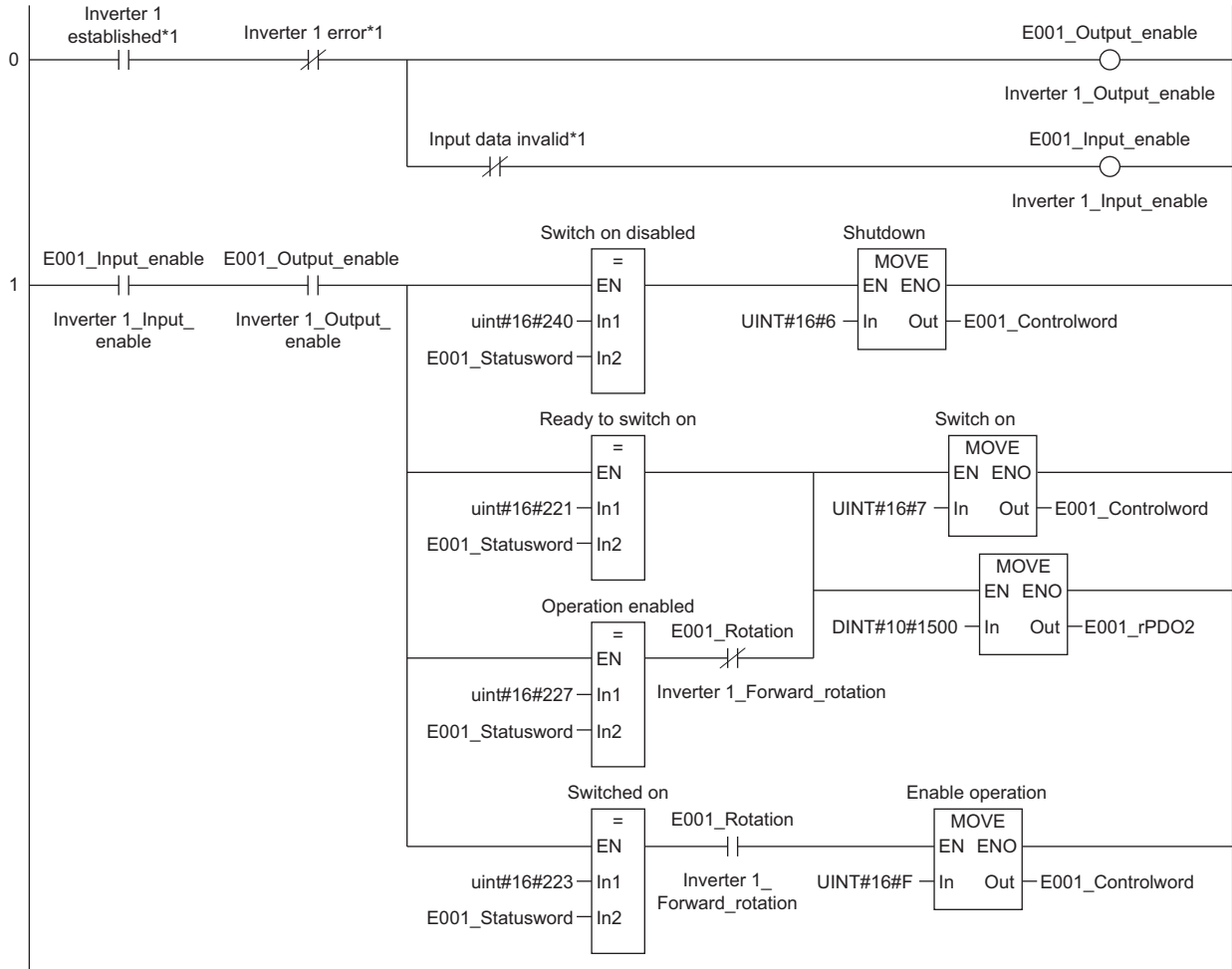

*1 Differs depending on the master used. Refer to the Master Module User's Manual.

2.14 Backup/restore

2.14.1 Outline

A backup/restore tool is available for backing up inverter parameters and the data used in the PLC function of inverter. The backup data can be used to restore the data in the inverter. (Not compatible with safety parameters of the safety communication model and the IP67 model)

This function is not supported depending on the date of manufacture of the inverter. For details of specification changes, refer to [page 290](#).

◆ System configuration

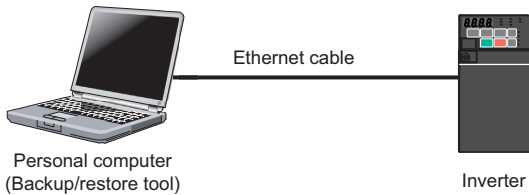

2.14.2 Initial setting for the backup/restore function

Use the following parameters to perform required settings for Ethernet communication between the inverter and other devices. To make communication between other devices and the inverter, perform the initial settings of the inverter parameters to match the communication specifications of the devices. Data communication cannot be made if the initial settings are not configured or if there is any setting error.

Pr.	Name	Initial value	Setting range	Setting range
1427 N630 ^{*1}	Ethernet function selection 1	5001	502, 5000 to 5002, 5006 to 5008, 5010 to 5013, 9999, 34962 ^{*3} , 44818 ^{*2} , 45237, 45238, 47808 ^{*2} , 61450	Set the application, protocol, and so on.
1428 N631 ^{*1}	Ethernet function selection 2	45237		
1429 N632 ^{*1}	Ethernet function selection 3	45238		
1430 N633 ^{*1}	Ethernet function selection 4	9999		

*1 The setting is applied after an inverter reset or next power-ON.

*2 The setting is available for the FR-E800-(SC)EPA and FR-E806-SCEPA.

*3 The setting is available for the FR-E800-(SC)EPB and FR-E806-SCEPB.

◆ Ethernet function selection (Pr.1427 to Pr.1430)

To use the backup/restore function, set "45237" (iQSS) in any of **Pr.1427 to Pr.1430 Ethernet function selection 1 to 4**. In the initial status, **Pr.1428** = "45237" (iQSS) and setting is not required. (Refer to [page 226](#).)

◆ Data to be backed up and restored

- The following data can be backed up and restored. The data other than those listed in the following table cannot be backed up or restored.

Item
Inverter parameters
Parameters used for activating the PLC function
Programs (including SFCs) used in the PLC function
Global device comment information used in the PLC function
Function block source information

 **NOTE**

- When files used in the PLC function are backed up while password protection is enabled for the files (read protection) and then the backed-up files are restored, password protection will be disabled.

◆ Backup/restore operation

- All inverter parameters and all data used in the PLC function of inverter can be backed up and restored.
- After restore operation, check the parameter setting values before starting operation.
- The backup/restore cannot be performed in the following cases.

Operation	Inverter status
Backup	During an inverter reset A password is registered or password protection is enabled (Pr.297 ≠ "9999"). During restore While password protection is enabled for files used in the PLC function (read protection)
Restore	During an inverter reset During running During auto tuning A password is registered or password protection is enabled (Pr.297 ≠ "9999"). While parameter write is disabled (Pr.77 = "1") During backup operation During the RUN status of the PLC function While password protection is enabled for files used in the PLC function (write protection)

- "RD" is displayed during backup and "WR" is displayed during restore on the operation panel, and the MS LED blinks in red.

 **NOTE**

- Restore operation is not available between different models (such as between the FR-E800 series and the FR-A800 series, the FR-E800-EPA inverter and the FR-E800-EPB inverter, and the Ethernet model and the safety communication model). An error occurs in the backup/restore tool.

2.15 Inverter-to-inverter link function

The inverter-to-inverter link function enables communication between multiple inverters connected by Ethernet in a small-scale system by using the I/O devices and special registers of the PLC function.

The inverter-to-inverter link function is enabled by simply setting **Pr.1124 Station number in inverter-to-inverter link** and **Pr.1125 Number of inverters in inverter-to-inverter link system**.

Pr.	Name	Initial value	Setting range	Description
1124 N681 ^{*1*2}	Station number in inverter-to-inverter link	9999	0 to 5	Set the station number for the inverter-to-inverter link function.
			9999	Inverter-to-inverter link function disabled
1125 N682 ^{*1*2}	Number of inverters in inverter-to-inverter link system	2	2 to 6	Set the total number of inverters used for the inverter-to-inverter link function.

*1 The setting is applied after an inverter reset or next power-ON.

*2 The setting is not available for the FR-E800-(SC)EPC.

◆ Communication specifications

The communication specification varies depending on the specification of the master.

Item	Description	
Communication speed	100 Mbps	
Number of connectable units	Master: 1 Slave: up to 5	
Topology	Line, star, or a combination of line and star	
Maximum number of links per station	Output device	16 (2 bytes)
	Special register	8 (16 bytes)

◆ Setting procedure

1. Set a value other than "0" in **Pr.414 PLC function operation selection** to enable the PLC function.
2. To set the inverter as the master, set "0" in **Pr.1124 Station number in inverter-to-inverter link**, and to set the inverter as a slave, select a station number from 1 to 5 and set the number in **Pr.1124**.
3. Set the total number of inverters used for the inverter-to-inverter link function in **Pr.1125 Number of inverters in inverter-to-inverter link system**. For example, set "3" in **Pr.1125** when two slave inverters and the master inverter are used.
4. Use FR Configurator2 to write sequence programs to the master inverter.

NOTE

- Use different station numbers for different devices. (If different devices have the same station number, the communication cannot be performed properly.)
- Set consecutive numbers for the station numbers. (Do not skip any numbers like 1, 2, then 4.)
- When **Pr.1124** is set to a value equal to or greater than the value set in **Pr.1125**, normal communication is not available.
- Use the Inverter-to-inverter linkup (LNK) signal to check that the master-slave communication is established. (For details of the LNK signal, refer to the FR-E800 Instruction Manual (Function).)
- To detect the interruption of the inverter-to-inverter link communication and activate the protective function, set **Pr.997 Fault initiation** in advance, and create and execute a sequence program to activate the protective function by the input of the signal loss detection signal from the external sensor.
- For the details of the PLC function, refer to the PLC Function Programming Manual and the Instruction Manual of FR Configurator2. For the details of FR Configurator2, refer to the Instruction Manual of FR Configurator2.

◆ System configuration

The following shows the system configuration for using the inverter-to-inverter link function. The master inverter can communicate with the slave inverters through one or two hubs (refer to the description of **Pr.1124** for the master/slave setting).

Device No.	Name	Description
SD1510 to SD1517	Inverter-to-inverter link send data 1 to 8 (slave 3)	Data 3 to 8 sent to slave 1
SD1518 to SD1525	Inverter-to-inverter link receive data 1 to 8 (slave 4)	Data 4 to 8 received from slave 1
SD1526 to SD1533	Inverter-to-inverter link send data 1 to 8 (slave 4)	Data 4 to 8 sent to slave 1
SD1534 to SD1541	Inverter-to-inverter link receive data 1 to 8 (slave 5)	Data 5 to 8 received from slave 1
SD1542 to SD1549	Inverter-to-inverter link send data 1 to 8 (slave 5)	Data 5 to 8 sent to slave 1

■ Special register (slave)

Device No.	Name	Description
SD1470 to SD1477	Inverter-to-inverter link receive data 1 to 8 (master)	Data 1 to 8 received from master
SD1478 to SD1485	Inverter-to-inverter link send data 1 to 8 (master)	Data 1 to 8 sent to master
SD1486 to SD1549	For manufacturer setting. Do not set.	

◆ Troubleshooting

Condition	Possible cause	Countermeasure
Communication is not established.	The same station number is assigned to multiple inverters.	Set Pr.1124 correctly.
	The station numbers are not consecutive.	Set Pr.1124 so that the station numbers are consecutive.
	The specified number of inverters in the system is not correct. (Pr.1124 is set to a value equal to or greater than the value set in Pr.1125 .)	Set Pr.1125 correctly.
	The connection is half-duplex.	Use full-duplex connection. (When Pr.1426 Link speed and duplex mode selection = "0 (initial value)", check that the hub and the Ethernet cable are compatible with full-duplex connection.)
	The inverter is not reset after Pr.1124 and Pr.1125 are set.	Reset the inverter.
A command sent by the master is not applied to a slave.	The PLC function is disabled.	Set a value other than "0" in Pr.414 to enable the PLC function.

2.16 Ethernet communication parameters

The following table shows parameters used in common for Ethernet communication protocols. Set the parameters as required.

Pr.	Name	Initial value	Setting range	Description	
442 N620 ^{*1*4}	Default gateway address 1	0	0 to 255	Enter the default gateway address.	
443 N621 ^{*1*4}	Default gateway address 2	0			
444 N622 ^{*1*4}	Default gateway address 3	0			
445 N623 ^{*1*4}	Default gateway address 4	0			
1399 N649 ^{*4}	Inverter identification enable/disable selection	1	0	Inverter identification disabled	
			1	Inverter identification enabled	
1427 N630 ^{*1*4}	Ethernet function selection 1	5001	502, 5000 to 5002, 5006 to 5008, 5010 to 5013, 9999 to 34962 ^{*3} , 44818 ^{*2} , 45237, 45238, 47808 ^{*2} , 61450	Set the application, protocol, etc.	
1428 N631 ^{*1*4}	Ethernet function selection 2	45237			
1429 N632 ^{*1*4}	Ethernet function selection 3	45238			
1430 N633 ^{*1*4}	Ethernet function selection 4	9999			
1431 N643 ^{*5}	Ethernet signal loss detection function selection	3	0	Signal loss detection disabled	<ul style="list-style-type: none"> • Pr.1457 = "0 to 3": The setting of Pr.1431 will be applied to the operation when signal loss is detected at PORT1, and the setting of Pr.1457 will be applied when signal loss is detected at PORT2. • Pr.1457 = "8888": When a signal loss is detected for both PORT1 and PORT2, the Pr.1431 setting is applied. • Pr.1457 = "9999": When a signal loss is detected for either PORT1 or PORT2, the Pr.1431 setting is applied.
			1	A warning (EHR) is output for a signal loss.	
			2	A warning (EHR) and the Alarm (LF) signal are output for a signal loss.	
			3	A warning (EHR) and the Alarm (LF) signal are output for a signal loss.	
				A protective function is activated for a signal loss. ^{*6*7}	
1438 N610 ^{*1*4}	Subnet mask 1	255	0 to 255	Enter the subnet mask of the network to which the inverter belongs.	
1439 N611 ^{*1*4}	Subnet mask 2	255			
1440 N612 ^{*1*4}	Subnet mask 3	255			
1441 N613 ^{*1*4}	Subnet mask 4	0			
1455 N642 ^{*4}	Keepalive time	60 s	1 to 7200 s	When no response is returned for an alive check message (Keep Alive ACK) for the time (s) set in Pr.1455 multiplied by 8 elapsed, the connection will be forced to be closed.	
1456 N647 ^{*4*8}	Network diagnosis selection	9999	0	Disabled	
			1	SNMP enabled	
			2	Duplicate IP address detection is enabled when link-up events occur.	
			9999	SNMP enabled Duplicate IP address detection is enabled when link-up events occur.	

Pr.	Name	Initial value	Setting range	Description
1457 N648*5	Extended setting for Ethernet signal loss detection function selection	9999	0	Signal loss detection disabled
			1	A warning (EHR) is output for a signal loss.
			2	A warning (EHR) and the Alarm (LF) signal are output for a signal loss
			3	A warning (EHR) and the Alarm (LF) signal are output for a signal loss.
				A protective function is activated for a signal loss.*6*7
			8888	When a signal loss is detected for both PORT1 and PORT2, the Pr.1431 setting is applied.
9999	When a signal loss is detected for either PORT1 or PORT2, the Pr.1431 setting is applied.			
1386 N652*4	Ethernet relay operation at reset selection	0	0, 9999	Select the relay operation for packets addressed to the other stations for resetting the inverter connected in line topology.

- *1 The setting is applied after an inverter reset or next power-ON.
- *2 The setting is available for the FR-E800-(SC)EPA and FR-E806-SCEPA.
- *3 The setting is available for the FR-E800-(SC)EPB and FR-E806-SCEPB.
- *4 The setting is not available for the FR-E800-(SC)EPC.
- *5 For CC-Link IE TSN communication, a protective function (E.EHR) is activated regardless of the Pr.1431 and Pr.1457 settings when a signal loss is detected during cyclic communication.
- *6 The protective function is not activated while the inverter stops or during an inverter reset.
- *7 The operation follows the Pr.502 Stop mode selection at communication error setting. (Refer to page 282.)
- *8 When "34962" is set in any of Pr.1427 to Pr.1430, SNMP is disabled regardless of the Pr.1456 setting.

◆ Default gateway address (Pr.442 to Pr.445)

Set the default gateway address in Pr.442 to Pr.445 to establish a communication with the devices on a different network.

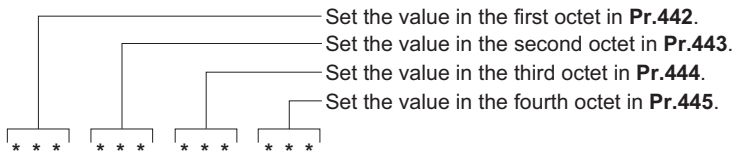

NOTE

- The setting is not available for the FR-E800-(SC)EPC.

◆ Ethernet function selection (Pr.1427 to Pr.1430)

Refer to the Instruction Manual of the device connected via Ethernet, and set Pr.1427 to Pr.1430 Ethernet function selection 1 to 4 according to the application and protocol.

Pr.1427 to Pr.1430 setting*1	Application	Protocol	Number of connectable clients
502	MODBUS/TCP	TCP/IP	3
5000	MELSOFT / FA product connection (Connection with a computer (FR Configurator2), GOT, or a relay station (programmable controller))	UDP	No limit
5001 (Pr.1427 initial value)*2		TCP/IP	2*3
5002*2		UDP	No limit
5006		TCP/IP	2*3
5007		UDP	No limit
5008		SLMP	UDP
5010	SLMP	TCP/IP	2*3
5011		UDP	No limit
5012		TCP/IP	2*3
5013	PROFINET	—	No limit
34962*5	EtherNet/IP	UDP	4
44818*4		TCP/IP	2
45237 (Pr.1428 initial value)	iQSS (supported by FR Configurator2)	UDP	No limit

Pr.1427 to Pr.1430 setting ^{*1}	Application	Protocol	Number of connectable clients
45238 (Pr.1429 initial value)	CC-Link IE TSN	—	No limit
47808 ^{*4}	BACnet/IP	UDP	No limit
61450	CC-Link IE Field Network Basic	UDP	No limit
9999 (Pr.1430 initial value)	Unselected		

*1 If both application and protocol settings are identical in Pr.1427 to Pr.1430, the priority of the setting is defined as follows: Pr.1427> Pr.1428> Pr.1429> Pr.1430.

(Example) When Pr.1427 = "5001", Pr.1428 = "5006", Pr.1429 = "5010", and Pr.1430 = "5012", "5001", "5010" and "5012" are valid.

*2 To connect the inverter and FR Configurator2 via the MELSOFT / FA product for Ethernet communication, set "5001 (initial value)" or "5002" according to the protocol type (UDP or TCP/IP) in any of Pr.1427 to Pr.1430.

*3 When the inverter is connected with other equipment via a hub, and if the communication between the other equipment and the hub is interrupted and resumed, the communication between the inverter and the other equipment may not be established depending on the specifications of the hub. To re-establish communication with the other equipment, reset the inverter to forcefully close the connection. (Setting a shorter time in Pr.1455 Keepalive time is also effective as a preventive measure (refer to page 228).)

*4 The setting is available for the FR-E800-(SC)EPA and FR-E806-SCEPA.

*5 The setting is available for the FR-E800-(SC)EPB and FR-E806-SCEPB.

NOTE

- The setting is not available for the FR-E800-(SC)EPC.
- For details of communication protocols that cannot be used together, refer to page 7.

◆ Ethernet signal loss detection (Pr.1431, Pr.1457)

Use Pr.1431 and Pr.1457 to set the operation when Ethernet communication is interrupted by physical factors including disconnection of the Ethernet cable or damages on the Ethernet cable.

Pr.1431 setting	Description	Applicable port			Operation panel indication	LF signal output
		Pr.1457 = "0 to 3"	Pr.1457 = "8888"	Pr.1457 = "9999"		
0	Detection disabled	PORT1	PORT1 and PORT2	PORT1 or PORT2	—	Not available
1	Warning output				EHR	Not available
2	Warning and alarm output				EHR	Available
3 (initial value)	Warning and alarm output				EHR	Available
	Protective function activation ^{*1}				*2	*2

Pr.1457 setting	Description	Applicable port	Operation panel indication	LF signal output
0	Detection disabled	PORT2	—	Not available
1	Warning output		EHR	Not available
2	Warning and alarm output		EHR	Available
3	Warning and alarm output		EHR	Available
	Protective function activation ^{*1}		*2	*2
8888	When a signal loss is detected for both PORT1 and PORT2, the Pr.1431 setting is applied.	PORT1 and PORT2		
9999 (initial value)	When a signal loss is detected for either PORT1 or PORT2, the Pr.1431 setting is applied.	PORT1 or PORT2	—	—

*1 The protective function is not activated while the inverter stops or during an inverter reset.

*2 The operation follows the Pr.502 Stop mode selection at communication error setting. (Refer to page 282.)

- Precautions for connection in line topology

For connection in line topology, set Pr.502 or configure a setting for signal loss detection for each port.

Example: Link-down of inverter 2 due to power-OFF or other reason (**Pr.1431** = "3 (initial value)", **Pr.1457** = "3")

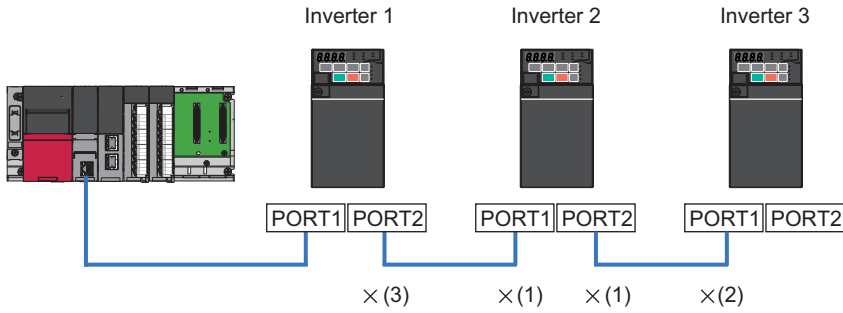

- (1) Link-down of inverter 2 due to power-OFF or other reason
- (2) "E.EHR" is displayed as the connection between PORT1 of inverter 3 and inverter 2 is interrupted.
- (3) "E.EHR" is displayed as the connection between PORT2 of inverter 1 and inverter 2 is interrupted.

NOTE

- Setting **Pr.1457** is not available for the FR-E800-EPC manufactured in August 2024 or earlier. The operation is the same as the one performed when **Pr.1457** = "9999".
- For CC-Link IE TSN communication, a protective function (E.EHR) is activated regardless of the **Pr.1431** and **Pr.1457** settings when a signal loss is detected during cyclic communication.

◆ Subnet mask (Pr.1438 to Pr.1441)

The subnet mask of the network to which the inverter belongs can be set in **Pr.1438 to Pr.1441**.

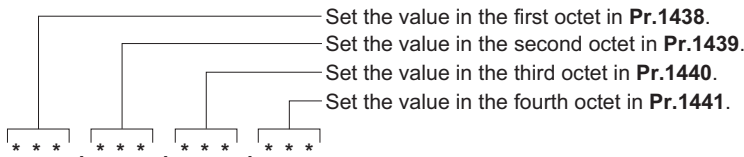

NOTE

- The setting is not available for the FR-E800-(SC)EPC.

◆ Keepalive time (Pr.1455)

An alive check message (KeepAlive ACK) is sent to a device if the device does not return any response within the time set in **Pr.1455 Keepalive time** while a TCP connection is established. When no response is returned after the seventh transmission, the connection will be forced to be closed.

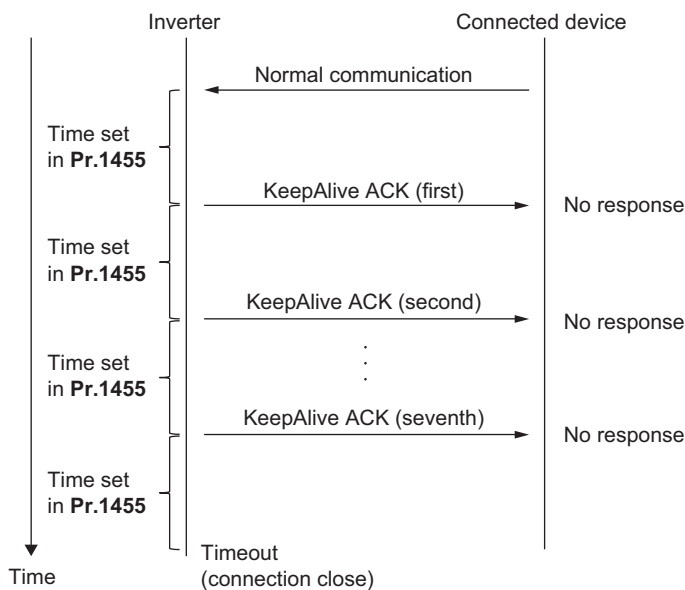

NOTE

- The setting is not available for the FR-E800-(SC)EPC.

◆ Network diagnosis selection (Pr.1456)

Pr.1456 setting	Description	Remarks
0	Disabled	
1	SNMP enabled	The network diagnosis function using SNMP is enabled.
2	Duplicate IP address detection is enabled when link-up events occur.	A protective function (DIP) is activated when an IP address overlapping with that of any other device on the network is detected.
9999	SNMP enabled Duplicate IP address detection is enabled when link-up events occur.	

NOTE

- The setting is not available for the FR-E800-(SC)EPC.
- When "34962" is set in any of **Pr.1427 to Pr.1430**, SNMP is disabled regardless of the **Pr.1456** setting.

◆ Ethernet relay operation at reset selection (Pr.1386)

Use this parameter to select whether to continue or stop the relay operation for packets addressed to the other stations when resetting the inverter connected in line topology. Setting this parameter prevents faults of other inverters caused by interruption of the relay operation when the inverter is reset to change settings or clear faults.

Pr.1386 setting	Description
0 (initial value)	The packet relay operation is continued when the inverter is reset.
9999	The packet relay operation is stopped when the inverter is reset.

Example: Resetting inverter 2 (**Pr.1431 and Pr.1457** = "3")

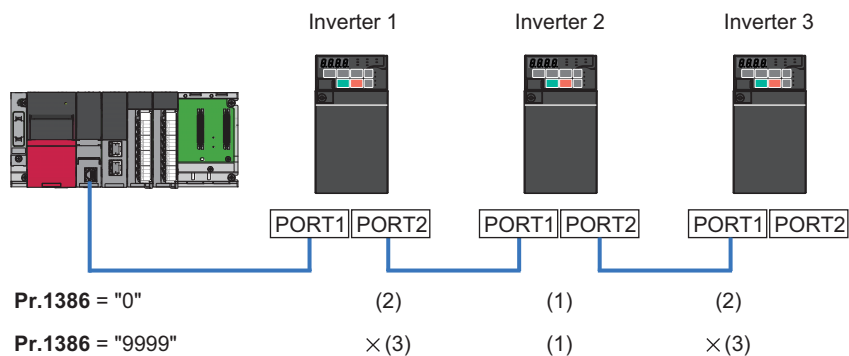

- (1) Reset inverter 2.
- (2) Relay operation is continued between inverter 2 and inverter 1 / inverter 3.
- (3) "E.EHR" is displayed as the connection between inverter 2 and inverter 1 / inverter 3 is interrupted.

NOTE

- The setting is not available for the FR-E800-(SC)EPC.
- When the setting in **Pr.1426 Link speed and duplex mode selection** or **Pr.1434 to Pr.1437** (IP address) is changed, the packet relay operation is stopped even when **Pr.1386** = "0".

MEMO

CHAPTER 3 RS-485 Communication

3.1	Outline	232
3.2	Wiring.....	232
3.3	Wiring of PU connector.....	234
3.4	Mitsubishi inverter protocol (computer link communication).....	236
3.5	MODBUS RTU.....	249
3.6	BACnet MS/TP	262

3 RS-485 Communication

3.1 Outline

RS-485 communication is available for the standard model or the standard model with the FR-E8TR or the FR-E8TE7 installed. Use the following parameters to perform required settings for RS-485 communication between the inverter and a personal computer.

- Use the PU connector on the inverter or the FR-E8TE7 and the RS-485 terminals on the FR-E8TR as communication interface.
- The Mitsubishi inverter protocol, MODBUS-RTU protocol, or BACnet MS/TP protocol is used. Parameter setting, monitoring, etc. can be performed through communication.
- To make communication between the personal computer and inverter, setting of the communication specifications must be configured in the inverter in advance. Data communication cannot be made if the initial settings are not configured or if there is any setting error.
- Position control using point tables is not available for RS-485 communication.
- For details on the FR-E8TR and the FR-E8TE7, refer to the Instruction Manual of each option.

3.2 Wiring

3.2.1 Wiring procedure

1. Prepare the equipment required for wiring according to the connection method.
2. Turn OFF the power of the programmable controller and the inverters.
3. Perform wiring between communication devices.
4. Connect a terminating resistor.

3.2.2 Connected device

◆ Computer-inverter connection cable

Refer to the following for the connection cable (USB to RS-485 converter) between the computer and an inverter. Commercially available products (as of April 2023)

Product name	Model	Manufacturer
Interface embedded cable dedicated for inverter ^{*1}	DINV-U4	Diatrend Corp.

^{*1} The conversion cable cannot connect multiple inverters. (The computer and inverter are connected in a 1:1 pair.) This is a USB-to-RS485 converter-embedded conversion cable. No additional cable or connector is required. For the product details, contact the manufacturer.

◆ Connection cable

Use Ethernet cables compliant with the following standards.

Ethernet cable	Connector	Standard
Category 5e or higher straight cable (double shielded/STP)	RJ-45 connector	The cables compliant with the following standards: <ul style="list-style-type: none">• IEEE 802.3 (1000BASE-T)• ANSI/TIA/EIA-568-B (Category 5e)

◆ Distributor

Use a distributor to connect a terminating resistor to the inverter.

Commercially available products (as of April 2023)

Product name	Model	Manufacturer
RS-485 distributor	BMJ-8-28N (Pins No. 2 and No. 8 are not connected internally.) (A plug with a terminating resistor is not used.)	HACHIKO ELECTRIC CO., LTD.
	DMDH-3PN (Pins No. 2 and No. 8 are not connected internally.) DMDH-10PN (Pins No. 2 and No. 8 are not connected internally.)	Diatrend Corp.

◆ Terminating resistor

Prepare a 100 Ω 1/2 W terminating resistor such as the following.

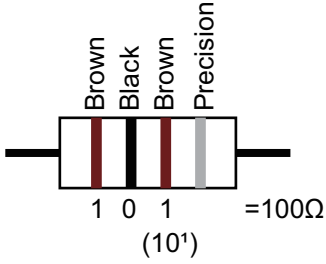

- Connect the terminating resistor between pin No. 3 (RDA) and pin No. 6 (RDB).
- Connect the terminating resistor to only the inverter remotest from the programmable controller.

3.3 Wiring of PU connector

Using the PU connector as a computer network port enables communication operation from a personal computer, etc. When the PU connector is connected with a personal, FA, or other computer by a communication cable, a user program can run and monitor the inverter or read and write to parameters.

◆ PU connector pin-outs

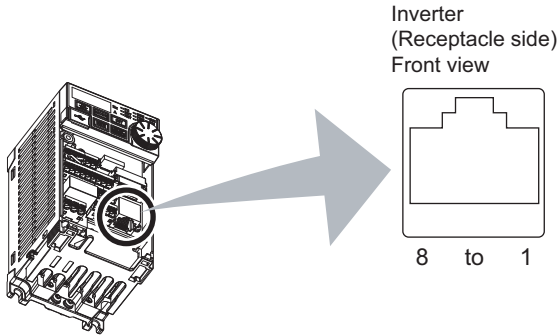

Pin number	Name	Description
1	SG	Earth (ground) (connected to terminal 5)
2	—	Operation panel power supply
3	RDA	Inverter receive+
4	SDB	Inverter send-
5	SDA	Inverter send+
6	RDB	Inverter receive-
7	SG	Earth (ground) (connected to terminal 5)
8	—	Operation panel power supply

NOTE

- Pins No. 2 and 8 provide power to the operation panel or parameter unit. Do not use these pins for RS-485 communication.
- Do not connect the PU connector to the computer's LAN board, FAX modem socket, or telephone modular connector. The product could be damaged due to differences in electrical specifications.

◆ Wiring method

- Connecting one inverter (four-wire type)

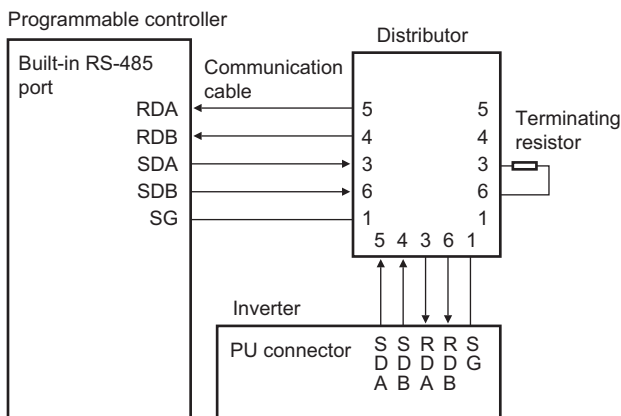

• Connecting multiple inverters (four-wire type)

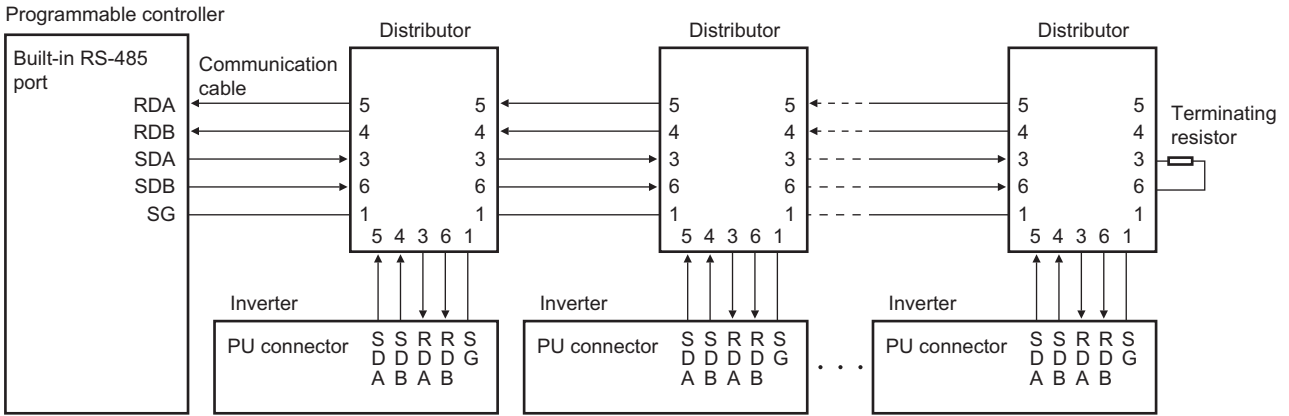

• Connecting one inverter (two-wire type)

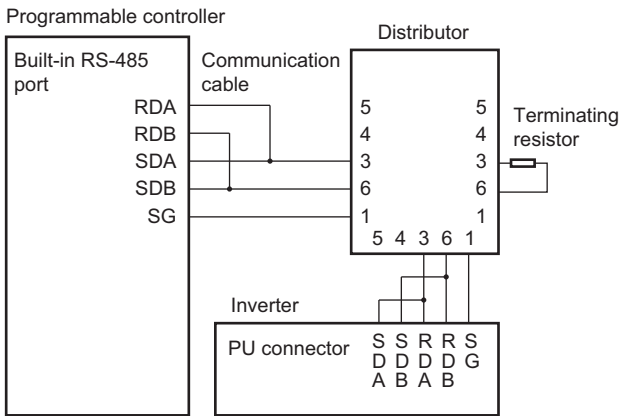

• Connecting multiple inverters (two-wire type)

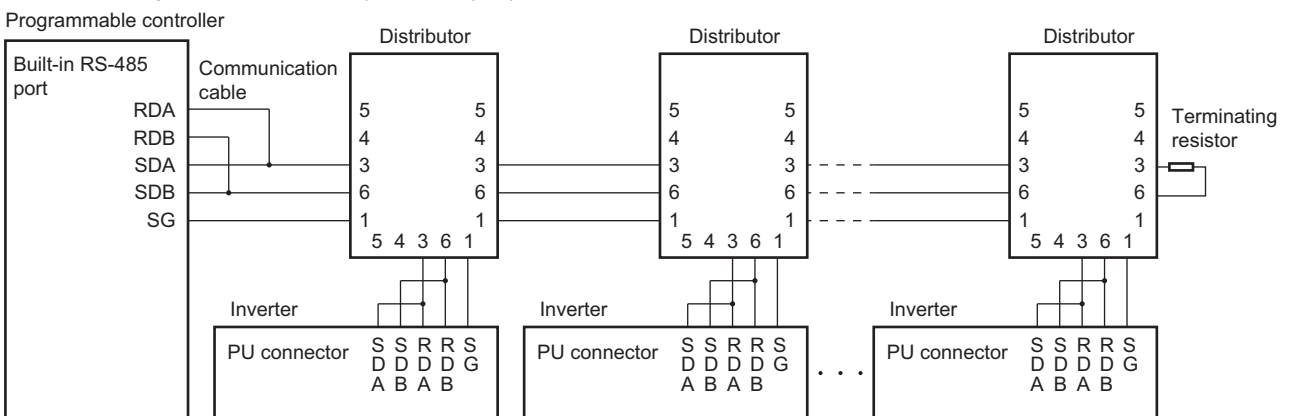

3.4 Mitsubishi inverter protocol (computer link communication)

Parameter setting and monitoring, etc. are possible by using the Mitsubishi inverter protocol (computer link communication) via the PU connector on the inverter.

To use the Mitsubishi inverter protocol (computer link communication), set "0 (initial value)" in **Pr.549 Protocol selection**.

Pr.	Name	Initial value	Setting range	Description	
549 N000	Protocol selection	0	0	Mitsubishi inverter protocol (computer link)	
			1	MODBUS RTU protocol	
			2	BACnet MS/TP protocol	
117 N020	PU communication station number	0	0 to 31*1	Specify the inverter station number. Enter the inverter station numbers when two or more inverters are connected to one personal computer.	
118 N021	PU communication speed	192	48, 96, 192, 384, 576, 768, 1152	Select the communication speed. The setting value × 100 equals the communication speed. For example, enter 192 to set the communication speed of 19200 bps.	
N022	PU communication data length	0	0	Data length 8 bits	
			1	Data length 7 bits	
N023	PU communication stop bit length	1	0	Stop bit length 1 bit	
			1	Stop bit length 2 bits	
119	PU communication stop bit length / data length	1	0	Stop bit length 1 bit	Data length 8 bits
			1	Stop bit length 2 bits	
			10	Stop bit length 1 bit	Data length 7 bits
			11	Stop bit length 2 bits	
120 N024	PU communication parity check	2	0	Parity check disabled.	
			1	Parity check (odd parity) enabled.	
			2	Parity check (even parity) enabled.	
121 N025	PU communication retry count	1	0 to 10	Set the permissible number of retries for unsuccessful data reception. If the number of consecutive errors exceeds the permissible value, the inverter output is shut off.	
			9999	The inverter output will not be shut off even when a communication error occurs.	
122 N026	PU communication check time interval	0	0	RS-485 communication is enabled. However, the inverter output is shut off if the operation mode is changed to the one for the selected command interface.	
			0.1 to 999.8 s	Set the interval of the communication check (signal loss detection) time. If a no-communication state persists for longer than the permissible time, the inverter output will be shut off.	
			9999	No communication check (signal loss detection)	
123 N027	PU communication waiting time setting	9999	0 to 150 ms	Set the delay between data transmission to the inverter and response.	
			9999	The time delay is not set in this parameter but in communication data. Delay time: Number set in the data × 10 ms	
124 N028	PU communication CR/LF selection	1	0	Without CR/LF	
			1	With CR	
			2	With CR/LF	

*1 When a value outside the setting range is set, the inverter operates at the initial value.

NOTE

- Always reset the inverter after making the initial settings of the parameters. After changing the communication-related parameters, communication cannot be made until the inverter is reset.

◆ Communication specifications

- The communication specifications are shown in the following table.

Item	Description	Related parameter
Communication protocol	Mitsubishi inverter protocol (computer link communication)	Pr.549

Item	Description	Related parameter	
Conforming standard	EIA-485 (RS-485)	—	
Number of connectable units	1: N (maximum 32 units), the setting range of station number is 0 to 31.	Pr.117	
Communication speed	Selected among 4800/9600/19200/38400/57600/76800/115200 bps.	Pr.118	
Control procedure	Asynchronous method	—	
Communication method	Half-duplex system	—	
Communication specifications	Character system	ASCII (7 bits or 8 bits can be selected.)	Pr.119
	Start bit	1 bit	—
	Stop bit length	1 bit or 2 bits can be selected.	Pr.119
	Parity check	Check (at even or odd numbers) or no check can be selected.	Pr.120
	Error check	Sum code check	—
	Terminator	CR/LF (whether or not to use it can be selected)	Pr.124
Time delay setting	Availability of the setting is selectable.	Pr.123	

◆ Communication procedure

- Data communication between the computer and inverter is made in the following procedure.

- Request data is sent from the computer to the inverter. (The inverter will not send data unless requested.)
- Communication waiting time
- The inverter sends reply data to the computer in response to the computer request.
- Inverter data processing time
- An answer from the computer in response to reply data (c) of the inverter is transmitted. (Even if (e) is not sent, subsequent communication is made properly.)

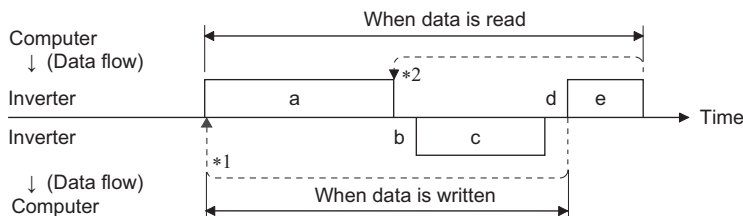

*1 If a data error is detected and a retry must be made, perform retry operation with the user program. The inverter output is shut off if the number of consecutive retries exceeds the parameter setting.

*2 On receipt of a data error occurrence, the inverter returns reply data (c) to the computer again. The inverter output is shut off if the number of consecutive data errors reaches or exceeds the parameter setting.

◆ Communication operation presence/absence and data format types

- Data communication between the computer and inverter is made in ASCII code (hexadecimal code).
- Communication operation presence/absence and data format types are as follows.

Symbol	Operation	Operation command	Running frequency	Multi command	Parameter write	Inverter reset	Monitor	Parameter read
a	Communication request is sent to the inverter in accordance with the user program in the computer.	A, A1	A (A2) ^{*1}	^{*3}	A (A2) ^{*2}	A	B	B
b	Inverter data processing time	With	With	With	With	Without	With	With
c	Reply data from the inverter (Data a is checked for an error.)	No error ^{*4} (Request accepted)	C	C	^{*3*6}	C ^{*5}	E, E1, E2, E3 ^{*1}	E (E2) ^{*2}
		With error (Request rejected)	D	D	D	D	D ^{*5}	D
d	Computer processing delay time	10 ms or more						
e	Reply from computer in response to reply data c (Data c is checked for error.)	No error ^{*4} (No inverter processing)	Without	Without	Without	Without	Without (C)	Without (C)
		With error (Inverter outputs c again.)	Without	Without	Without	Without	Without	F

*1 When Pr.53 = "4" and the data code HFF = 1, the data format is A2 or E2. (Refer to page 243.)

*2 The data writing format is A2 and the data reading format is E2 for Pr.37. (Refer to page 243.)

*3 Refer to page 247 for multi command data formats.

*4 In the communication request data from the computer to the inverter, the time of 10 ms or more is also required after an acknowledgment (ACK) signal showing "No data error detected" is sent. (Refer to page 241.)

*5 Reply from the inverter to the inverter reset request can be selected. (Refer to [page 243](#).)

*6 At mode error and data range error, data on [page 247](#) contains an error code. Except for those errors, the error is returned with data format D.

• Data writing format

a. Communication request data from the computer to the inverter

Format	Number of characters															
	1	2	3	4	5	6	7	8	9	10	11	12	13	14	15	
A	ENQ ^{*1}	Inverter station number ^{*2}		Instruction code		^{*3}	Data				Sum check		^{*4}			
A1	ENQ ^{*1}	Inverter station number ^{*2}		Instruction code		^{*3}	Data	Sum check		^{*4}						
A2	ENQ ^{*1}	Inverter station number ^{*2}		Instruction code		^{*3}	Data					Sum check		^{*4}		

c. Reply data from the inverter to the computer (No data error detected)

Format	Number of characters			
	1	2	3	4
C	ACK ^{*1}	Inverter station number ^{*2}		^{*4}

c. Reply data from the inverter to the computer (Data error detected)

Format	Number of characters				
	1	2	3	4	5
D	NAK ^{*1}	Inverter station number ^{*2}		Error code	^{*4}

*1 Indicates a control code.

*2 The inverter station number is specified in hexadecimal in the range of H00 to H1F (stations No. 0 to 31).

*3 Set the delay time. When **Pr.123 PU communication waiting time setting** is set to other than "9999", create the communication request data without "delay time" in the data format. (The number of characters decreases by 1.)

*4 CR+LF code: When a computer transmits data to the inverter, some computers automatically provide either one or both of the codes CR (carriage return) and LF (line feed) at the end of a data group. In this case, the same setting is required for data sent from the inverter to the computer. Use **Pr.124 PU communication CR/LF selection** for the CR+LF code setting.

• Data reading format

a. Communication request data from the computer to the inverter

Format	Number of characters								
	1	2	3	4	5	6	7	8	9
B	ENQ ^{*1}	Inverter station number ^{*2}		Instruction code		^{*3}	Sum check		^{*4}

c. Reply data from the inverter to the computer (No data error detected)

Format	Number of characters													
	1	2	3	4	5	6	7	8	9	10	11	12	13	
E	STX ^{*1}	Inverter station number ^{*2}		Read data				ETX ^{*1}	Sum check		^{*4}			
E1	STX ^{*1}	Inverter station number ^{*2}		Read data		ETX ^{*1}	Sum check		^{*4}					
E2	STX ^{*1}	Inverter station number ^{*2}		Read data					ETX ^{*1}	Sum check		^{*4}		

Format	Number of characters										
	1	2	3	4 to 23				24	25	26	27
E3	STX ^{*1}	Inverter station number ^{*2}		Read data (Inverter model information)				ETX ^{*1}	Sum check		^{*4}

c. Reply data from the inverter to the computer (Data error detected)

Format	Number of characters				
	1	2	3	4	5
D	NAK ^{*1}	Inverter station number ^{*2}		Error code	^{*4}

e. Transmission data from the computer to the inverter when reading data

Format	Number of characters			
	1	2	3	4
C (No data error detected)	ACK ^{*1}	Inverter station number ^{*2}		^{*4}
F (Data error detected)	NAK ^{*1}	Inverter station number ^{*2}		^{*4}

*1 Indicates a control code.

*2 The inverter station number is specified in hexadecimal in the range of H00 to H1F (stations No. 0 to 31).

*3 Set the delay time. When **Pr.123 PU communication waiting time setting** is set to other than "9999", create the communication request data without "delay time" in the data format. (The number of characters decreases by 1.)

*4 CR+LF code: When a computer transmits data to the inverter, some computers automatically provide either one or both of the codes CR (carriage return) and LF (line feed) at the end of a data group. In this case, the same setting is required for data sent from the inverter to the computer. Use **Pr.124 PU communication CR/LF selection** for the CR+LF code setting.

◆ Data definitions

- Control code

Signal name	ASCII code	Description
STX	H02	Start Of Text (Start of data)
ETX	H03	End Of Text (End of data)
ENQ	H05	Enquiry (Communication request)
ACK	H06	Acknowledge (No data error detected)
LF	H0A	Line Feed
CR	H0D	Carriage Return
NAK	H15	Negative Acknowledge (Data error detected)

- Inverter station number
Specify the station number of the inverter which communicates with the computer.
- Instruction code
Specify the processing request, for example, operation or monitoring, given by the computer to the inverter. Therefore, the operation or monitoring an item is enabled by specifying the corresponding instruction code. (Refer to [page 243.](#))
- Data
Indicates the data such as frequency and parameters transferred to and from the inverter. The definitions and ranges of set data are determined in accordance with the instruction codes. (Refer to [page 243.](#))
- Time delay
Specify the delay time (time period between the time when the inverter receives data from the computer and the time when the inverter starts transmission of reply data). Set the delay time in accordance with the response time of the computer in the range of 0 to 150 ms in 10 ms increments. (For example, "1" for 10 ms or "2" for 20 ms.)
When **Pr.123 PU communication waiting time setting** is set to other than "9999", create the communication request data without "delay time" in the data format. (The number of characters decreases by 1.)

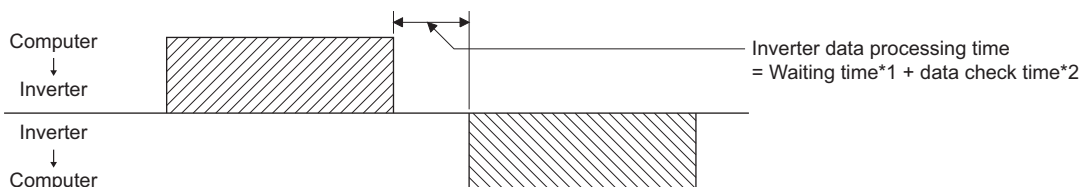

*1 When **Pr.123** = "9999", the waiting time is the data setting value × 10 ms. When **Pr.123** ≠ "9999", the waiting time is the value set in **Pr.123**.

*2 Approximately 5 to 50 ms. It varies depending on the instruction code.

NOTE

- The data check time varies depending on the instruction code. (Refer to [page 241.](#))

- Sum check code

The sum check code is a 2-digit ASCII (hexadecimal) representing the lower 1 byte (8 bits) of the sum derived from the checked ASCII data.

(Example 1)

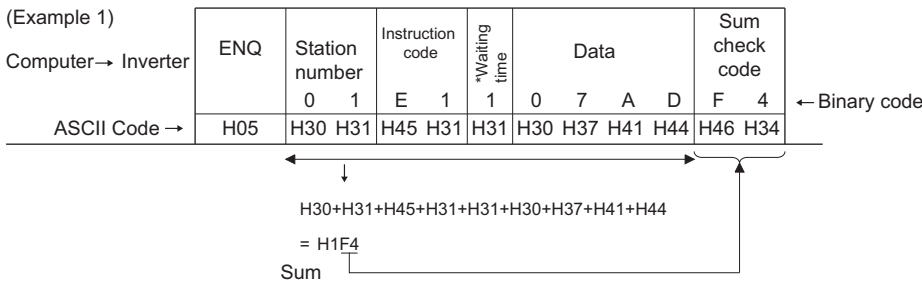

* When Pr.123 PU communication waiting time setting ≠ "9999", create the communication request data without "waiting time" in the data format. (The number of characters decreases by 1.)

(Example 2)

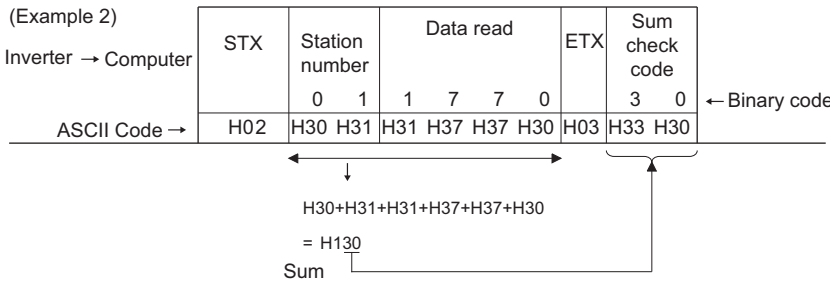

- Error code

If any error is found in the data received by the inverter, its error definition is sent back to the computer together with the NAK code.

Error code	Error item	Error description	Inverter operation
H0	Computer NAK error	The number of errors consecutively detected in communication request data from the computer is greater than the permissible number of retries.	The inverter output is shut off (E.PUE) if error occurs continuously more than the permissible number of retries. The LF signal is output.
H1	Parity error	The parity check result does not match the specified parity.	
H2	Sum check error	The sum check code in the computer does not match that of the data received by the inverter.	
H3	Protocol error	The data received by the inverter has a grammatical mistake. Or, data receive is not completed within the predetermined time. The CR or LF code specification is not the same as the setting of the parameter.	
H4	Framing error	The stop bit length differs from the initial setting.	
H5	Overrun error	New data has been sent by the computer before the inverter completes receiving the preceding data.	
H6	—	—	—
H7	Character error	The character received is invalid (other than 0 to 9, A to F, control code).	The inverter does not accept the received data. However, the inverter output is not shut off.
H8	—	—	—
H9	—	—	—
HA	Mode error	Parameter write was attempted when the inverter does not perform computer link communication, when the operation commands are not given through communication, or during inverter operation.	The inverter does not accept the received data. However, the inverter output is not shut off.
HB	Instruction code error	The specified instruction code does not exist.	
HC	Data range error	Invalid data has been specified for parameter writing, frequency setting, etc.	
HD	—	—	
HE	—	—	—
HF	Normal (no error)	—	—

◆ Response time

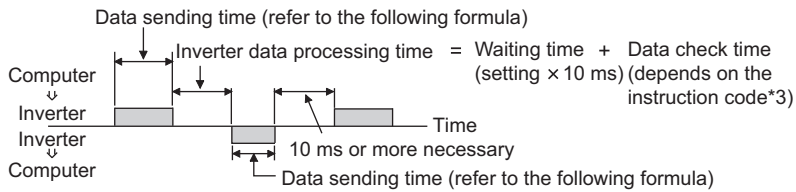

[Formula for data transmission time]

$$\frac{1}{\text{Communication speed (bps)}} \times \text{Number of data characters}^*1 \times \text{Communication specifications (Total number of bits)}^*2 = \text{data transmission time (s)}$$

*1 Refer to [page 237](#).

*2 Communication specifications

Name		Number of bits
Stop bit length		1 bit
		2 bits
Data length		7 bits
		8 bits
Parity check	With	1 bit
	Without	0

In addition to the above, 1 start bit is necessary.

Minimum number of total bits: 9 bits

Maximum number of total bits: 12 bits

*3 Data check time

Item	Check time
Operation command, inverter status monitor, reading the monitor item, reading/writing the set frequency (RAM)	< 20 ms
Reading/writing the set frequency (EEPROM)	< 40 ms
Reading/writing parameters (RAM)	< Approximately 20 ms
Reading/writing parameters (EEPROM)	< Approximately 50 ms

◆ Retry count setting (Pr.121)

- Set the permissible number of retries at data receive error occurrence. (Refer to [page 240](#) for data receive error for retry.)
- When the data receive errors occur consecutively and the number of retries exceeds the permissible number setting, a communication fault (E.PUE) occurs and the inverter output is shut off.
- When a data transmission error occurs while "9999" is set, the inverter does not shut off its output but outputs the Alarm (LF) signal. To use the LF signal, set "98" (positive logic) or "198" (negative logic) in any of **Pr.190 to Pr.197 (Output terminal function selection)** to assign the function to an output terminal.

Example: Pr.121 = "1" (initial value)

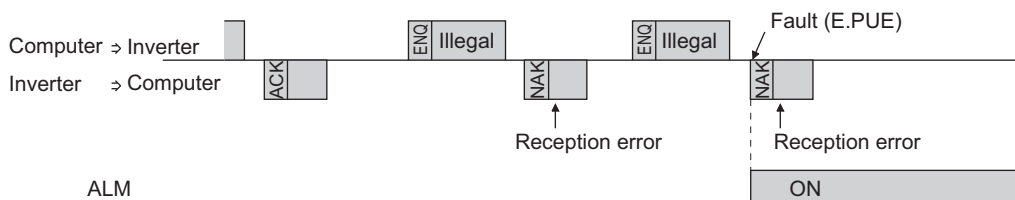

Example: Pr.121 = "9999"

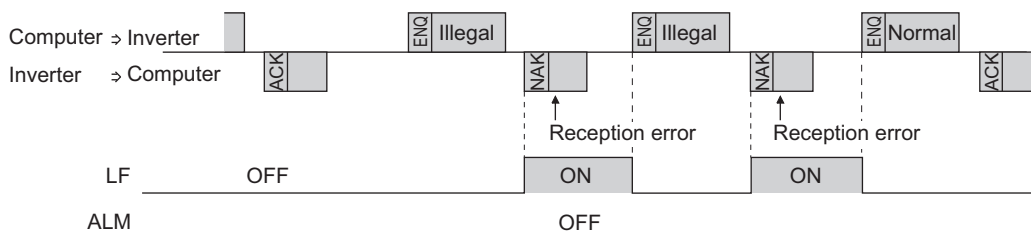

NOTE

- The operation at a communication error occurrence depends on the setting of **Pr.502 Stop mode selection at communication error**. (Refer to [page 282](#).)

◆ Signal loss detection (Pr.122)

- If signal loss is detected between the inverter and computer, the communication error "E.PUE" will occur and the inverter output will be shut off.
- When a signal loss is detected, the LF signal is output.
- When "9999" is set, the communication check (signal loss detection) will not be performed.
- The monitor items and parameter settings can be read via RS-485 communication when "0" is set, but a communication error (E.PUE) occurs instantly when the operation mode is switched to the one for the selected command interface (Network operation mode in the initial setting).
- Setting any value from 0.1 s to 999.8 s will enable signal loss detection. To detect signal loss, data must be sent from the computer within the communication check time interval (for further information on control codes, refer to [page 239](#)). The inverter makes a communication check (clearing of communication check counter) regardless of the station number setting of the data sent from the master.
- Communication check is started at the initial communication in the operation mode for the selected command interface (Network operation mode in the initial setting).

Example: Pr.122 = "0.1 to 999.8s"

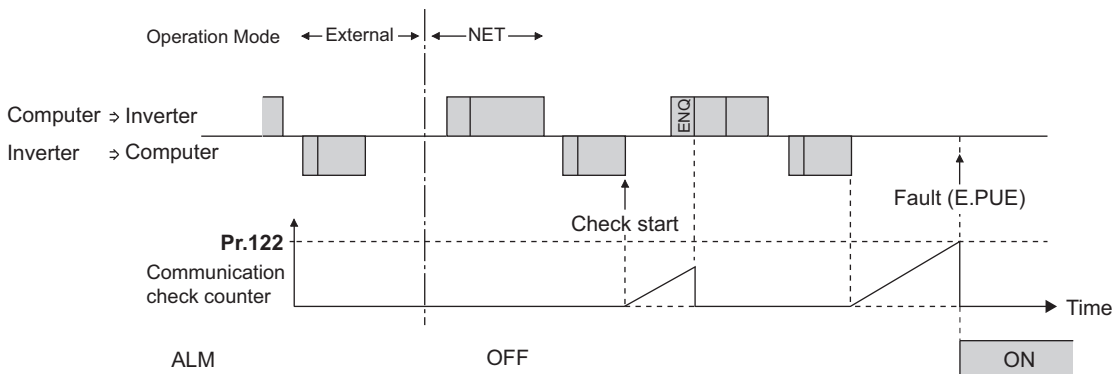

◆ Programming instructions

- When data from the computer has any error, the inverter does not accept that data. Hence, in the user program, always insert a retry program for data error.
- All data communication such as the operation command or monitoring are started when the computer gives a communication request. The inverter does not return any data without the computer's request. Hence, design the program so that the computer gives a data read request for monitoring, etc. as required.

⚠ CAUTION

- Always set the communication check time interval before starting operation to prevent hazardous conditions.
- Data communication is not started automatically but is made only once when the computer provides a communication request. If communication is disabled during operation due to signal cable breakage or other factors, the inverter cannot be stopped. When the communication check time interval has elapsed, the inverter output will be shut off (E.PUE). Turn the RES signal of the inverter ON or shut off the power supply to coast the motor to a stop.
- If communication is broken due to signal cable breakage, computer fault, or other factors, the inverter does not detect such a fault. This should be fully noted.

◆ Setting items and set data

- After completion of parameter settings, set the instruction codes and data as shown in the following table, then start communication from the computer to allow various types of operation control and monitoring.

Item	Read/write	Instruction code	Data description	Number of data digits (format) ^{*1}																			
Operation mode	Read	H7B	H0000: Network operation H0001: External operation, External operation (JOG operation) H0002: PU operation, External/PU combined operation, PUJOG operation	4 digits (B and E/D)																			
	Write	HFB	H0000: Network operation H0001: External operation H0002: PU operation	4 digits (A and C/D)																			
Monitor	Output frequency / rotations per minute (machine speed)	Read	H6F	H0000 to HFFFF: Output frequency in 0.01 Hz increments (The display can be changed to the rotations per minute (machine speed) using Pr.37 and Pr.53 . Refer to the FR-E800 Instruction Manual (Function).)	4 digits (B and E (E2) / D)																		
	Output current	Read	H70	H0000 to HFFFF: Output current (hexadecimal) in 0.01 A increments	4 digits (B and E/D)																		
	Output voltage	Read	H71	H0000 to HFFFF: Output voltage (hexadecimal) in 0.1 V increments	4 digits (B and E/D)																		
	Special monitor	Read	H72	H0000 to HFFFF: Data of the monitor item selected with the instruction code HF3.	4 digits (B and E (E2) / D)																		
	Special monitor selection No.	Read	H73	Monitor selection data (Refer to the FR-E800 Instruction Manual (Function) for details on selection No.)	2 digits (B and E1/D)																		
		Write	HF3		2 digits (A1 and C/D)																		
	Fault record	Read	H74 to H78	H0000 to HFFFF: Two fault records per code. (For details on fault record read data, refer to the FR-E800 Instruction Manual (Maintenance).)	4 digits (B and E/D)																		
				H74		<table border="1" style="width: 100%; text-align: center;"> <tr> <td style="width: 50%;">b15</td> <td style="width: 50%;">b8</td> <td style="width: 50%;">b7</td> <td style="width: 50%;">b0</td> </tr> <tr> <td colspan="2">Second latest fault</td> <td colspan="2">Latest fault</td> </tr> </table>	b15	b8	b7	b0	Second latest fault		Latest fault										
				b15		b8	b7	b0															
				Second latest fault		Latest fault																	
H75				<table border="1" style="width: 100%; text-align: center;"> <tr> <td style="width: 50%;">Fourth latest fault</td> <td style="width: 50%;">Third latest fault</td> </tr> </table>		Fourth latest fault	Third latest fault																
Fourth latest fault				Third latest fault																			
H76	<table border="1" style="width: 100%; text-align: center;"> <tr> <td style="width: 50%;">Sixth latest fault</td> <td style="width: 50%;">Fifth latest fault</td> </tr> </table>	Sixth latest fault	Fifth latest fault																				
Sixth latest fault	Fifth latest fault																						
H77	<table border="1" style="width: 100%; text-align: center;"> <tr> <td style="width: 50%;">Eighth latest fault</td> <td style="width: 50%;">Seventh latest fault</td> </tr> </table>	Eighth latest fault	Seventh latest fault																				
Eighth latest fault	Seventh latest fault																						
H78	<table border="1" style="width: 100%; text-align: center;"> <tr> <td style="width: 50%;">Tenth latest fault</td> <td style="width: 50%;">Ninth latest fault</td> </tr> </table>	Tenth latest fault	Ninth latest fault																				
Tenth latest fault	Ninth latest fault																						
<p>For instruction code H74, read data H30A0</p> <table border="1" style="width: 100%; text-align: center;"> <tr> <td style="width: 50%;">b15</td> <td style="width: 50%;">b8</td> <td style="width: 50%;">b7</td> <td style="width: 50%;">b0</td> </tr> <tr> <td>0</td><td>0</td><td>1</td><td>1</td><td>0</td><td>0</td><td>0</td><td>0</td><td>1</td><td>0</td><td>1</td><td>0</td><td>0</td><td>0</td><td>0</td><td>0</td> </tr> </table> <p style="text-align: center;"> Second latest fault (H30) Latest fault (HA0) </p> <p style="text-align: center;"> Second latest fault THT Latest fault OPT </p>				b15	b8	b7	b0	0	0	1	1	0	0	0	0	1	0	1	0	0	0	0	0
b15	b8	b7	b0																				
0	0	1	1	0	0	0	0	1	0	1	0	0	0	0	0								
Operation command (extended)	Write	HF9	Control input commands such as the Forward rotation command (STF) signal and the Reverse rotation command (STR) signal can be set. (For the details, refer to page 246 .)	4 digits (A and C/D)																			
Operation command	Write	HFA		2 digits (A1 and C/D)																			
Operation command (extended 2)	Write	HFE		4 digits (A and C/D)																			
Inverter status monitor (extended)	Read	H79	The states of the output signals such as the Forward rotation output, Reverse rotation output, and Inverter running (RUN) signals can be monitored. (For the details, refer to page 246 .)	4 digits (B and E/D)																			
Inverter status monitor	Read	H7A		2 digits (B and E1/D)																			
Inverter status monitor (extended 2)	Read	H7E		4 digits (B and E/D)																			

Item	Read/write	Instruction code	Data description	Number of data digits (format) ^{*1}	
Set frequency (RAM)	Read	H6D	Read the set frequency or rotations per minute (machine speed) from the RAM or EEPROM.	4 digits (B and E (E2) / D)	
Set frequency (EEPROM)		H6E	H0000 to HFFFF: Set frequency in 0.01 Hz increments (The display can be changed to the rotations per minute (machine speed) using Pr.37 and Pr.53 . Refer to the FR-E800 Instruction Manual (Function).)		
Set frequency (RAM)	Write	HED	Write the set frequency or rotations per minute (machine speed) into the RAM or EEPROM.	4 digits (A (A2) and C/D)	
Set frequency (RAM, EEPROM)		HEE	H0000 to HE678 (0 to 590.00 Hz): Frequency in 0.01 Hz increments. (The display can be changed to the rotations per minute (machine speed) using Pr.37 and Pr.53 . Refer to the FR-E800 Instruction Manual (Function).) To change the set frequency consecutively, write data to the RAM of the inverter. (Instruction code: HED)		
Inverter reset	Write	HFD	H9696: Inverter reset As the inverter is reset at the start of communication by the computer, the inverter cannot send reply data back to the computer.	4 digits (A and C/D)	
			H9966: Inverter reset After the computer correctly starts communication and send data to the inverter, the inverter returns the ACK signal to the computer before being reset.	4 digits (A and D)	
Fault history clear	Write	HF4	H9696: Fault history is cleared.	4 digits (A and C/D)	
Parameter clear / All parameter clear	Write	HFC	All parameters return to initial values. Whether to clear communication parameters or not can be selected according to the data. • Parameter clear H9696: Parameters including communication parameters are cleared. H5A5A: Parameters other than communication parameters are cleared. ^{*3} • All parameter clear H9966: Parameters including communication parameters are cleared. H55AA: Parameters other than communication parameters are cleared. ^{*3} For the details of whether or not to clear parameters, refer to the FR-E800 Instruction Manual (Function). When a clear is performed with H9696 or H9966, communication related parameter settings also return to the initial values. When resuming the operation, set the parameters again. Performing a clear will clear the instruction code HEC, HF3, and HFF settings. Only H9966 and H55AA (All parameter clear) are valid when a password is set (refer to the FR-E800 Instruction Manual (Function)).	4 digits (A and C/D)	
			Read		H00 to H6B
Link parameter extended setting	Read	H7F	Parameter settings are changed according to the instruction code settings.	2 digits (B and E1/D)	
	Write	HFF	For details of the settings, refer to the instruction code list in the FR-E800 Instruction Manual (Function).	2 digits (A1 and C/D)	
Second parameter changing (instruction code HFF = 1, 9)	Read	H6C	When setting the calibration parameters ^{*4}	2 digits (B and E1/D)	
	Write	HEC	H00: Frequency ^{*5} H01: Parameter-set analog value H02: Analog value input from terminal	2 digits (A1 and C/D)	
Multi command	Read/write	HF0	Available for writing 2 commands, and monitoring 2 items for reading data. (Refer to page 247 for details.)	10 digits (^{*2} /D)	
Product profile	Model	Read	H7C	The inverter model can be read in ASCII code. "H20" (blank code) is set for blank area. Example) FR-E820-1: H46, H52, H2D, H45, H38, H32, H30, H2D, H31, H20, H20 ... H20	20 digits (B and E3/D)
	Capacity	Read	H7D	The capacity in the inverter model can be read in ASCII code. Data is read in increments of 0.1 kW, and rounds down to 0.01 kW increments. "H20" (blank code) is set for blank area. Example) 0.75K: " 7" (H20, H20, H20, H20, H20, H37)	6 digits (B and E2/D)

*1 Refer to [page 237](#) for data formats (A, A1, A2, B, C, D, E, E1, E2, E3, F).

*2 Refer to [page 247](#) for multi command data formats.

*3 Turning OFF the power supply while clearing parameters with H5A5A or H55AA returns the communication parameter settings to the initial settings.

*4 Refer to the following calibration parameter list for details on the calibration parameters.

*5 The gain frequency can be also written using **Pr.125** (instruction code: H99) or **Pr.126** (instruction code: H9A).

NOTE

- Set 65520 (HFFF0) as a parameter value "8888" and 65535 (HFFFF) as "9999".
- For the instruction codes HFF, HEC, and HF3, their values once written are held, but cleared to zero when an inverter reset or all clear is performed.
- When a 32-bit parameter setting or monitor item is read and the value to be read exceeds HFFFF, HFFFF is returned.

Example) When reading the **C3 (Pr.902)** and **C6 (Pr.904)** settings from the inverter of station No. 0.

	Computer send data	Inverter send data	Description
a	ENQ 00 FF 0 01 7D	ACK 00	"H01" is set in the extended link parameter.
b	ENQ 00 EC 0 01 79	ACK 00	"H01" is set in the second parameter changing.
c	ENQ 00 5E 0 0A	STX 00 0000 ETX 20	C3 (Pr.902) is read. 0% is read.
d	ENQ 00 60 0 F6	STX 00 0000 ETX 20	C6 (Pr.904) is read. 0% is read.

To read/write **C3 (Pr.902)** or **C6 (Pr.904)** after inverter reset or parameter clear, execute from (a) again.

◆ List of calibration parameters

Pr.	Name	Instruction code		
		Read	Write	Extended
C2 (902)	Terminal 2 frequency setting bias frequency	5E	DE	1
C3 (902)	Terminal 2 frequency setting bias	5E	DE	1
125 (903)	Terminal 2 frequency setting gain frequency	5F	DF	1
C4 (903)	Terminal 2 frequency setting gain	5F	DF	1
C5 (904)	Terminal 4 frequency setting bias frequency	60	E0	1
C6 (904)	Terminal 4 frequency setting bias	60	E0	1
126 (905)	Terminal 4 frequency setting gain frequency	61	E1	1
C7 (905)	Terminal 4 frequency setting gain	61	E1	1
C12 (917)*1	Terminal 1 bias frequency (speed)	11	91	9
C13 (917)*1	Terminal 1 bias (speed)	11	91	9
C14 (918)*1	Terminal 1 gain frequency (speed)	12	92	9
C15 (918)*1	Terminal 1 gain (speed)	12	92	9
C16 (919)*1	Terminal 1 bias command (torque)	13	93	9
C17 (919)*1	Terminal 1 bias (torque)	13	93	9
C18 (920)*1	Terminal 1 gain command (torque)	14	94	9
C19 (920)*1	Terminal 1 gain (torque)	14	94	9
C38 (932)	Terminal 4 bias command (torque)	20	A0	9
C39 (932)	Terminal 4 bias (torque)	20	A0	9
C40 (933)	Terminal 4 gain command (torque)	21	A1	9
C41 (933)	Terminal 4 gain (torque)	21	A1	9
C42 (934)	PID display bias coefficient	22	A2	9
C43 (934)	PID display bias analog value	22	A2	9
C44 (935)	PID display gain coefficient	23	A3	9
C45 (935)	PID display gain analog value	23	A3	9

*1 Available only when the FR-E8AXY is installed.

◆ Operation command

Item	Instruction code	Bit length	Description	Example
Operation command	HFA	8 bits	b0: Terminal 4 input selection b1: Forward rotation command b2: Reverse rotation command b3: RL (Low-speed operation command) ^{*1} b4: RM (Middle-speed operation command) ^{*1} b5: RH (High-speed operation command) ^{*1} b6: Second function selection b7: MRS (Output stop) ^{*1}	[Example 1] H02 Forward rotation b7 b0 0 0 0 0 0 0 1 0 [Example 2] H00 Stop b7 b0 0 0 0 0 0 0 0 0
Operation command (extended)	HF9	16 bits	b0: Terminal 4 input selection b1: Forward rotation command b2: Reverse rotation command b3: RL (Low-speed operation command) ^{*1} b4: RM (Middle-speed operation command) ^{*1} b5: RH (High-speed operation command) ^{*1} b6: Second function selection b7: MRS (Output stop) ^{*1} b8: JOG operation selection 2 b9: — b10: — b11: RES (Inverter reset) ^{*1*2} b12 to b15: —	[Example 1] H0002 Forward rotation b15 b0 0 0 0 0 0 0 0 0 0 0 0 0 0 0 1 0 [Example 2] H0804 Low-speed reverse operation (When Pr.184 RES terminal function selection is set to "0") b15 b0 0 0 0 0 1 0 0 0 0 0 0 0 0 0 1 0 0
Operation command (extended 2)	HFE	16 bits	b0: NET X1 (—) ^{*1} b1: NET X2 (—) ^{*1} b2: NET X3 (—) ^{*1} b3: NET X4 (—) ^{*1} b4: NET X5 (—) ^{*1} b5 to b15: —	[Example] H0001 Low-speed operation (When Pr.185 NET X1 terminal function selection is set to "0") b15 b0 0 0 0 0 0 0 0 0 0 0 0 0 0 0 0 1

*1 The signal within parentheses () is the initial status. The function changes depending on the setting of **Pr.180 to Pr.189 (Input terminal function selection)**. For details, refer to the description of **Pr.180 to Pr.189 (Input terminal function selection)** in the FR-E800 Instruction Manual (Function).

*2 Resetting cannot be controlled over a network, so in the initial status bit 11 is invalid. To use bit 11, change the signal by **Pr.184 RES terminal function selection**. (A reset can be executed by the instruction code HFD.)
 For details of **Pr.184**, refer to the FR-E800 Instruction Manual (Function).

◆ Inverter status monitor

Item	Instruction code	Bit length	Description	Example
Inverter status monitor	H7A	8 bits	b0: RUN (Inverter running) ^{*1} b1: Forward running b2: Reverse running b3: Up to frequency b4: Overload alarm b5: — b6: FU (Output frequency detection) ^{*1} b7: ABC (Fault) ^{*1}	[Example 1] H03... During forward rotation b7 b0 0 0 0 0 0 0 1 1 [Example 2] H80... Stop at fault occurrence b7 b0 1 0 0 0 0 0 0 0

Item	Instruction code	Bit length	Description	Example
Inverter status monitor (extended)	H79	16 bits	b0: RUN (Inverter running) ^{*1} b1: Forward running b2: Reverse running b3: Up to frequency b4: Overload alarm b5: — b6: FU (Output frequency detection) ^{*1} b7: ABC (Fault) ^{*1} b8: ABC2 (–) ^{*1} b9: Safety monitor output 2 ^{*2} b10 to b14: – b15: Fault occurrence	[Example 1] H0003...During forward rotation b15 b0 0 0 0 0 0 0 0 0 0 0 0 0 0 0 0 1 1 [Example 2] H8080...Stop at fault occurrence b15 b0 1 0 0 0 0 0 0 0 1 0 0 0 0 0 0 0 0
Inverter status monitor (extended 2)	H7E	16 bits	b0: NET Y1 (–) ^{*1} b1: NET Y2 (–) ^{*1} b2: NET Y3 (–) ^{*1} b3: NET Y4 (–) ^{*1} b4 to b15: –	[Example] H0001... Stop at fault occurrence (When "99 (positive logic)" or "199 (negative logic)" is set in Pr.193 NET Y1 terminal function selection) b15 b0 0 0 0 0 0 0 0 0 0 0 0 0 0 0 0 0 1

*1 The signal within parentheses () is the initial status. The function changes depending on the setting of Pr.190 to Pr.197 (Output terminal function selection). For details, refer to the description of Pr.190 to Pr.197 (Output terminal function selection) in the FR-E800 Instruction Manual (Function).

*2 Fixed to 0 when the FR-E8TR or the FR-E8TE7 is installed.

◆ Multi command (HF0)

- Sending data format from computer to inverter

Number of characters																		
1	2	3	4	5	6	7	8	9	10	11	12	13	14	15	16	17	18	19
ENQ	Inverter station number	Instruction code (HF0)			Time delay ^{*1}	Send data type ^{*2}	Receive data type ^{*3}	Data 1 ^{*4}				Data 2 ^{*4}				Sum check	CR/LF ^{*7}	

- Reply data format from inverter to computer (No data error detected)

Number of characters																		
1	2	3	4	5	6	7	8	9	10	11	12	13	14	15	16	17	18	19
STX	Inverter station number	Send data type ^{*2}	Receive data type ^{*3}	Error code 1 ^{*6}	Error code 2 ^{*6}	Data 1 ^{*5}				Data 2 ^{*5}				ETX	Sum check	CR/LF ^{*7}		

*1 Set the delay time. When Pr.123 PU communication waiting time setting is set to other than "9999", create the communication request data without "delay time" in the data format. (The number of characters decreases by 1.)

*2 Specify the data type of sending data (from computer to inverter). To use the data type 4, specify "4" for both the send data type and the receive data type.

*3 Specify the data type of reply data (from inverter to computer). To use the data type 4, specify "4" for both the send data type and the receive data type.

*4 Combination of data 1 and data 2 for sending

Data type	Data 1	Data 2	Remarks
0	Operation command (extended)	Set frequency (RAM)	Operation command (extended) is the same as instruction code HF9. (Refer to page 246.)
1	Operation command (extended)	Set frequency (RAM, EEPROM)	
4	Monitor code 1	Monitor code 2	Set the special monitor selection No. in the monitor codes 1 and 2 (set "00" in the upper 2 digits).
5	Operation command (extended)	Operation command (extended 2)	Operation command (extended) is the same as instruction code HF9. (Refer to page 246.) Operation command (extended 2) is the same as instruction code HFE. (Refer to page 246.)
6	Operation command (extended 2)	Set frequency (RAM)	
7	Operation command (extended 2)	Set frequency (RAM, EEPROM)	

*5 Combination of data 1 and data 2 for reply

Data type	Data 1	Data 2	Remarks
0	Inverter status monitor (extended)	Output frequency / rotations per minute (machine speed)	The inverter status monitor (extended) data is the same as the data of instruction code H79. (Refer to page 246.)
1	Inverter status monitor (extended)	Special monitor	The monitor item specified in instruction code HF3 is returned for the special monitor. (Refer to page 246.)
4	Monitor 1	Monitor 2	Monitor items specified by the send data type 4 are returned for the monitor 1 and monitor 2. When the send data type is other than "4", the current monitor value is returned for the monitor 1 and the output frequency monitor value is returned for the monitor 2.
5	Inverter status monitor (extended)	Inverter status monitor (extended 2)	The inverter status monitor (extended) data is the same as the data of instruction code H79. (Refer to page 246.)
6	Inverter status monitor (extended 2)	Output frequency / rotations per minute (machine speed)	The inverter status monitor (extended 2) data is the same as the data of instruction code H7E. (Refer to page 246.)
7	Inverter status monitor (extended 2)	Special monitor	The monitor item specified in instruction code HF3 is returned for the special monitor. (Refer to the FR-E800 Instruction Manual (Function).)

*6 The error code for sending data 1 is set in error code 1, and the error code for sending data 2 is set in error code 2. The mode error (HA), instruction code error (HB), data range error (HC) or no error (HF) is returned. (Refer to the FR-E800 Instruction Manual (Maintenance) for the details of the error codes.)

*7 CR+LF code: When a computer transmits data to the inverter, some computers automatically provide either one or both of the codes CR (carriage return) and LF (line feed) at the end of a data group. In this case, the same setting is required for data sent from the inverter to the computer. Use **Pr.124 PU communication CR/LF selection** for the CR+LF code setting.

3.5 MODBUS RTU

Operation or parameter setting via communication is possible using the MODBUS RTU communication protocol through the PU connector on the inverter.

To use MODBUS RTU, set "1" in **Pr.549 Protocol selection**.

Pr.	Name	Initial value	Setting range	Description	
549 N000	Protocol selection	0	0	Mitsubishi inverter protocol (computer link)	
			1 ^{*1}	MODBUS RTU protocol	
			2	BACnet MS/TP protocol	
117 N020	PU communication station number	0	0	Broadcast communication	
			1 to 247	Specify the inverter station number. Enter the inverter station numbers when two or more inverters are connected to one personal computer.	
118 N021	PU communication speed	192	48, 96, 192, 384 ^{*1} , 576, 768, 1152	Select the communication speed. The setting value × 100 equals the communication speed. For example, enter 96 to set the communication speed of 9600 bps.	
N023	PU communication stop bit length	1	0	Stop bit length 1 bit	Valid when Pr.N024 (Pr.120) = "0"
			1	Stop bit length 2 bits	
119	PU communication stop bit length / data length	1	0	Stop bit length 1 bit	Valid when Pr.120 = "0"
			1	Stop bit length 2 bits	
			10	Stop bit length 1 bit	
			11	Stop bit length 2 bits	
120 N024	PU communication parity check	2	0	Parity check disabled. Stop bit length selectable between 1 bit and 2 bits (depending on the setting of Pr.119).	
			1	Parity check (odd parity) enabled. Stop bit length: 1 bit.	
			2	Parity check (even parity) enabled. Stop bit length: 1 bit.	
122 N026	PU communication check time interval	0	0	RS-485 communication is enabled. However, the inverter output is shut off if the operation mode is changed to the one for the selected command interface.	
			0.1 to 999.8 s	Set the interval of the communication check (signal loss detection) time. If a no-communication state persists for longer than the permissible time, the inverter output will be shut off.	
			9999	No communication check (signal loss detection)	
343 N080	Communication error count	0	(0 to 999)	Displays the communication error count during MODBUS RTU communication. Read-only.	

*1 When **Pr.549** = "1 (MODBUS RTU)" and **Pr.118** = "384 (38400 bps)", the parameter unit is not available. To use the parameter unit, set a value other than "384" in **Pr.118** and perform an inverter reset.

NOTE

- If MODBUS RTU communication is performed from the client to the address 0 (station number 0), the data is broadcasted, and the inverter does not send any reply to the client. To obtain replies from the inverter, set **Pr.117 PU communication station number** ≠ "0 (initial value)".
- Some functions are disabled in broadcast communication. (Refer to [page 251](#).)
- If a communication option is installed with **Pr.550 NET mode operation command source selection** = "9999 (initial value)", commands (operation commands) transmitted through the PU connector become invalid. (Refer to the FR-E800 Instruction Manual (Function).)
- Always reset the inverter after making the initial settings of the parameters. After changing the communication-related parameters, communication cannot be made until the inverter is reset.

◆ Communication specifications

- The communication specifications are shown in the following table.

Item	Description	Related parameter
Communication protocol	MODBUS RTU protocol	Pr.549

Item	Description	Related parameter	
Conforming standard	EIA-485 (RS-485)	—	
Number of connectable units	1: N (maximum 32 units), setting is 0 to 247 stations	Pr.117	
Communication speed	Selected among 4800/9600/19200/38400/57600/76800/115200 bps.	Pr.118	
Control procedure	Asynchronous method	—	
Communication method	Half-duplex system	—	
Communication specifications	Character system	Binary (fixed at 8 bits)	
	Start bit	1 bit	
	Stop bit length	Select from the following three types: No parity check, stop bit length 1 bit / 2 bits (depends on the setting of Pr.119)	Pr.119 Pr.120
	Parity check	Odd parity check, stop bit length 1 bit Even parity check, stop bit length 1 bit	
	Error check	CRC code check	—
Terminator	Not available	—	
Time delay setting	Not available	—	

◆ Outline

- The MODBUS communication protocol was developed by Modicon for programmable controllers.
- The MODBUS protocol uses exclusive message frames to perform serial communication between a client and servers. These exclusive message frames are provided with a feature called "functions" that allows data to be read or written. These functions can be used to read or write parameters from the inverter, write input commands to the inverter or check the inverter's operating status, for example. This product classifies the data of each inverter into holding register area (register address 40001 to 49999). The client can communicate with inverters (servers) by accessing pre-assigned holding register addresses.

NOTE

- There are two serial transmission modes, the ASCII (American Standard Code for Information Interchange) mode and the RTU (Remote Terminal Unit) mode. However, this product supports only the RTU mode, which transfers 1 byte data (8 bits) as it is. Also, only communication protocol is defined by the MODBUS protocol. Physical layers are not stipulated.

◆ Message format

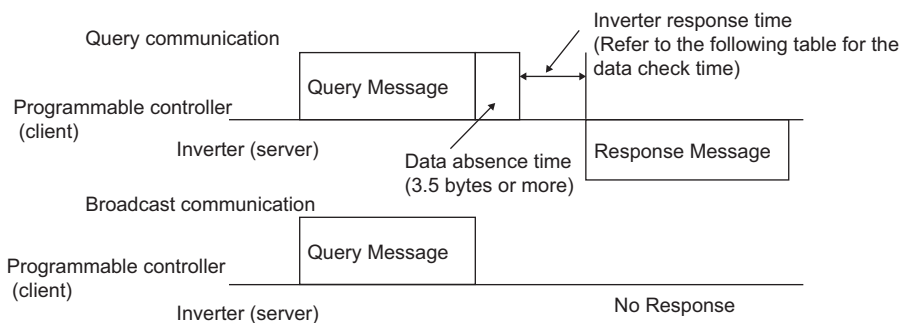

- Data check time

Item	Check time
Monitoring, operation command, frequency setting (RAM)	< 20 ms
Frequency setting (EEPROM)	< 50 ms
Reading/writing parameters	< Approximately 50 ms
Parameter clear / All parameter clear	Less than 5 s
Reset command	No reply

- Query
A message is sent to the server (the inverter) having the address specified by the client.
- Normal Response
After the query from the client is received, the server executes the request function, and returns the corresponding normal response to the client.

- Error Response

When an invalid function code, address or data is received by the server, the error response is returned to the client. This response is appended with an error code that indicates the reason why the request from the client could not be executed.

This response cannot be returned for errors, detected by the hardware, frame error and CRC check error.

- Broadcast

The client can broadcast messages to all servers by specifying address 0. All servers that receive a message from the client execute the requested function. With this type of communication, servers do not return a response to the client.

NOTE

- During broadcast communication, functions are executed regardless of the set inverter station number (Pr.117).

◆ Message frame (protocol)

- Communication method

Basically, the client sends a query message (inquiry), and servers return a response message (response). At normal communication, the device address and function code are copied as they are, and at erroneous communication (illegal function code or data code), bit 7 (= H80) of the function code is turned ON, and the error code is set at data bytes.

Query message from client

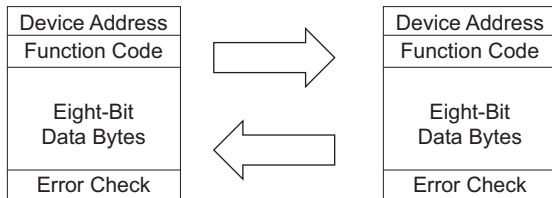

Response message from server

Message frames comprise the four message fields shown in the figures above.

A server recognizes message data as one message when a 3.5 character long no-data time (T1: start/end) is added before and after the data.

- Details of protocol

The following table explains the four message fields.

Start	Address	Function	Data	CRC check		End
T1	8 bits	8 bits	n × 8 bits	L 8 bits	H 8 bits	T1

Message field	Description
Address field	"0 to 247" can be set in the single-byte (8-bit) length field. Set "0" when sending broadcast messages (instructions to all addresses), and "1 to 247" to send messages to individual servers. The response from the server also contains the address set by the client. The value set in Pr.117 PU communication station number is the server address.
Function field	"1 to 255" can be set as the function code in the single-byte (8-bit) length field. The client sets the function to be sent to the server as the request, and the server performs the requested operation. Refer to the function code list for details of the supported function codes. An error response is generated when a function code other than those in the function code list is set. The normal response from the server contains the function code set by the client. The error response contains H80 and the function code.
Data field	The format changes according to the function code. (Refer to page 252 .) The data, for example, includes the byte count, number of bytes, and accessing content of holding registers.
CRC check field	Errors in the received message frame are detected. Errors are detected in the CRC check, and the 2 bytes length data is appended to the message. When the CRC is appended to the message, the lower bytes of the CRC are appended first, followed by the upper bytes. The CRC value is calculated by the sender that appends the CRC to the message. The receiver recalculates the CRC while the message is being received, and compares the calculation result against the actual value that was received in the error check field. If the two values do not match, the result is treated as an error.

◆ Function code list

Function name	Read/write	Code	Outline	Broadcast communication	Message format reference page
Read holding registers	Read	H03	The data of the holding registers is read. The various data of the inverter can be read from MODBUS registers. System environmental variable (Refer to page 257.) Monitor code (Refer to the FR-E800 Instruction Manual (Function).) Fault history (Refer to page 259.) Model information monitor (Refer to page 259.) Inverter parameters (Refer to page 258.)	Not available	page 252
Write single register	Write	H06	Data is written to a holding register. Data can be written to MODBUS registers to output instructions to the inverter or set parameters. System environmental variable (Refer to page 257.) Inverter parameters (Refer to page 258.)	Available	page 253
Diagnostics	Read	H08	Functions are diagnosed. (Communication check only) A communication check can be made since the query message is sent and the query message is returned as it is as the return message (subfunction code H00 function). Subfunction code H00 (Return query data).	Not available	page 253
Write multiple registers	Write	H10	Data is written to multiple consecutive holding registers. Data can be written to consecutive multiple MODBUS registers to output instructions to the inverter or set parameters. System environmental variable (Refer to page 257.) Inverter parameters (Refer to page 258.)	Available	page 254
Read holding register access log	Read	H46	The number of registers that were successfully accessed by the previous communication is read. Queries by function codes H03, H06, and H10 are supported. The number and start address of holding registers successfully accessed by the previous communication are returned. "0" is returned for both the number and start address for queries other than function codes H03, H06, and H10.	Not available	page 255

◆ Read holding registers (reading data of holding registers) (H03 or 03)

- Query message

a. Server address	b. Function code	c. Starting address		d. Quantity of registers		CRC check	
(8 bits)	H03 (8 bits)	H (8 bits)	L (8 bits)	H (8 bits)	L (8 bits)	L (8 bits)	H (8 bits)

- Normal response (Response message)

a. Server address	b. Function code	e. Byte count	f. Register value			CRC check	
(8 bits)	H03 (8 bits)	(8 bits)	H (8 bits)	L (8 bits)	... (n × 16 bits)	L (8 bits)	H (8 bits)

- Query message setting

Message		Description
a	Server address	Set the address to send messages to. Broadcast communication is not possible. (Invalid when "0" is set.)
b	Function code	Set H03.
c	Starting address	Set the holding register address from which to start reading the data. Starting address = start register address (decimal) - 40001 For example, when starting register address 0001 is set, the data of holding register address 40002 is read.
d	Quantity of registers	Set the number of holding registers for reading data. Data can be read from up to 125 registers.

- Content of normal response

Message		Description
e	Byte count	The setting range is H02 to HFA (2 to 250). Twice the number of reads specified by (d) is set.
f	Register value	The amount of data specified by (d) is set. Read data is output Hi bytes first followed by Lo bytes, and is arranged as follows: data of start address, data of start address+1, data of start address+2, and so forth.

■ Example) Read the register values of 41004 (Pr.4) to 41006 (Pr.6) from server address 17 (H11).

Query message

Server address	Function code	Starting address		Quantity of registers		CRC check	
H11 (8 bits)	H03 (8 bits)	H03 (8 bits)	HEB (8 bits)	H00 (8 bits)	H03 (8 bits)	H77 (8 bits)	H2B (8 bits)

Normal response (Response message)

Server address	Function code	Byte count	Register value						CRC check	
H11 (8 bits)	H03 (8 bits)	H06 (8 bits)	H17 (8 bits)	H70 (8 bits)	H0B (8 bits)	HB8 (8 bits)	H03 (8 bits)	HE8 (8 bits)	H2C (8 bits)	HE6 (8 bits)

Read value

Register 41004 (Pr.4): H1770 (60.00 Hz)

Register 41005 (Pr.5): H0BB8 (30.00 Hz)

Register 41006 (Pr.6): H03E8 (10.00 Hz)

◆ Write single register (writing data to holding registers) (H06 or 06)

- The content of the system environmental variables and inverter parameters (refer to [page 257](#)) assigned to the holding register area can be written.
- Query message

a. Server address	b. Function code	c. Register address		d. Register value		CRC check	
(8 bits)	H06 (8 bits)	H (8 bits)	L (8 bits)	H (8 bits)	L (8 bits)	L (8 bits)	H (8 bits)

- Normal response (Response message)

a. Server address	b. Function code	c. Register address		d. Register value		CRC check	
(8 bits)	H06 (8 bits)	H (8 bits)	L (8 bits)	H (8 bits)	L (8 bits)	L (8 bits)	H (8 bits)

- Query message setting

Message	Description
a Server address	Set the address to send messages to. Setting "0" enables broadcast communication.
b Function code	Set H06.
c Register address	Set the holding register address to write data to. Register address = holding register address (decimal) - 40001 For example, when register address 0001 is set, data is written to holding register address 40002.
d Register value	Set the data to write to the holding register. Write data is fixed at 2 bytes.

- Content of normal response
The contents in the normal response (a to d, including the CRC check) are the same as those in the query messages.
In the case of broadcast communication, no response is returned.

■ Example) Write 60 Hz (H1770) to 40014 (set frequency RAM) of server address 5 (H05).

Query message

Server address	Function code	Register address		Register value		CRC check	
H05 (8 bits)	H06 (8 bits)	H00 (8 bits)	H0D (8 bits)	H17 (8 bits)	H70 (8 bits)	H17 (8 bits)	H99 (8 bits)

Normal response (Response message)

The same data as those in the query message

NOTE

- With broadcast communication, no response is generated even if a query is executed, so when the next query is made, it must be made after waiting for the inverter data processing time after the previous query is executed.

◆ Diagnostics (diagnosis of functions) (H08 or 08)

- A communication check can be made since the query message is sent and the query message is returned as it is as the return message (subfunction code H00 function). Subfunction code H00 (Return query data)

- Query message

a. Server address	b. Function code	c. Sub-function		d. Data		CRC check	
(8 bits)	H08 (8 bits)	H00 (8 bits)	H00 (8 bits)	H (8 bits)	L (8 bits)	L (8 bits)	H (8 bits)

- Normal response (Response message)

a. Server address	b. Function code	c. Sub-function		d. Data		CRC check	
(8 bits)	H08 (8 bits)	H00 (8 bits)	H00 (8 bits)	H (8 bits)	L (8 bits)	L (8 bits)	H (8 bits)

- Query message setting

Message		Description
a	Server address	Set the address to send messages to. Broadcast communication is not possible. (Invalid when "0" is set.)
b	Function code	Set H08.
c	Sub-function	Set H0000.
d	Data	Any 2-byte long data can be set. The setting range is H0000 to HFFFF.

- Content of normal response

The contents in the normal response (a to d, including the CRC check) are the same as those in the query messages.

NOTE

- With broadcast communication, no response is generated even if a query is executed, so when the next query is made, it must be made after waiting for the inverter data processing time after the previous query is executed.

◆ Write multiple registers (writing data to multiple holding registers) (H10 or 16)

- Data can be written to multiple holding registers.
- Query message

a. Server address	b. Function code	c. Starting address		d. Quantity of registers		e. Byte count	f. Register value			CRC check	
(8 bits)	H10 (8 bits)	H (8 bits)	L (8 bits)	H (8 bits)	L (8 bits)	(8 bits)	H (8 bits)	L (8 bits)	... (n × 2 × 8 bits)	L (8 bits)	H (8 bits)

- Normal response (Response message)

a. Server address	b. Function code	c. Starting address		d. Quantity of registers		CRC check	
(8 bits)	H10 (8 bits)	H (8 bits)	L (8 bits)	H (8 bits)	L (8 bits)	L (8 bits)	H (8 bits)

- Query message setting

Message		Description
a	Server address	Set the address to send messages to. Setting "0" enables broadcast communication.
b	Function code	Set H10.
c	Starting address	Set the holding register address from which to start writing the data. Starting address = start register address (decimal) - 40001 For example, when starting address 0001 is set, data is written to holding register 40002.
d	Quantity of registers	Set the number of holding registers for writing data. Data can be written to up to 125 registers.
e	Byte count	The setting range is H02 to HFA (2 to 250). Set twice the value specified by d.
f	Register value	Set the amount of data specified by d. Write data is output Hi bytes first followed by Lo bytes, and is arranged as follows: data of start address, data of start address+1, data of start address+2, and so forth.

- Content of normal response

The contents in the normal response (a to d, including the CRC check) are the same as those in the query messages.

■ Example) Write 0.5 s (H05) to 41007 (Pr.7) and 1 s (H0A) to 41008 (Pr.8) of server address 25 (H19).

Query message

Server address	Function code	Starting address		Quantity of registers		Byte count	Register value				CRC check	
H19 (8 bits)	H10 (8 bits)	H03 (8 bits)	HEE (8 bits)	H00 (8 bits)	H02 (8 bits)	H04 (8 bits)	H00 (8 bits)	H05 (8 bits)	H00 (8 bits)	H0A (8 bits)	H86 (8 bits)	H3D (8 bits)

Normal response (Response message)

Server address	Function code	Starting address		Quantity of registers		CRC check	
H19 (8 bits)	H10 (8 bits)	H03 (8 bits)	HEE (8 bits)	H00 (8 bits)	H02 (8 bits)	H22 (8 bits)	H61 (8 bits)

◆ Read holding register access log (H46 or 70)

- Queries by function codes H03, H06, and H10 are supported. The number and start address of holding registers successfully accessed by the previous communication are returned. "0" is returned for both the number and start address for queries other than the function codes above.
- Query message

a. Server address	b. Function code	CRC check	
(8 bits)	H46 (8 bits)	L (8 bits)	H (8 bits)

- Normal response (Response message)

a. Server address	b. Function code	c. Starting address		d. No. of points		CRC check	
(8 bits)	H46 (8 bits)	H (8 bits)	L (8 bits)	H (8 bits)	L (8 bits)	L (8 bits)	H (8 bits)

- Query message setting

Message		Description
a	Server address	Set the address to send messages to. Broadcast communication is not possible. (Invalid when "0" is set.)
b	Function code	Set H46.

- Content of normal response

Message		Description
c	Starting address	The start address of the holding register that was successfully accessed is returned. Starting address = start register address (decimal) - 40001 For example, when starting address 0001 is returned, the holding register address that was successfully accessed is 40002.
d	No. of points	The number of holding registers that were successfully accessed is returned.

■ Example) Read the successful register start address and number of successful accesses from server address 25 (H19).

Query message

Server address	Function code	CRC check	
H19 (8 bits)	H46 (8 bits)	H8B (8 bits)	HD2 (8 bits)

Normal response (Response message)

Server address	Function code	Starting address		No. of points		CRC check	
H19 (8 bits)	H10 (8 bits)	H03 (8 bits)	HEE (8 bits)	H00 (8 bits)	H02 (8 bits)	H22 (8 bits)	H61 (8 bits)

The number of holding registers that were successfully accessed was returned as two with the start address 41007 (Pr.7).

◆ Error response

- An error response is returned if the query message received from the client contains an illegal function, address or data. No response is returned for parity, CRC, overrun, framing, and busy errors.

NOTE

- No response is also returned in the case of broadcast communication.

- Error response (Response message)

a. Server address	b. Function code	c. Exception code	CRC check	
(8 bits)	H80 + Function (8 bits)	(8 bits)	L (8 bits)	H (8 bits)

	Message	Description
a	Server address	Set the address received from the client.
b	Function code	The function code requested by the client and H80 is set.
c	Exception code	The codes in the following table are set.

- Error code list

Code	Error item	Error description
01	ILLEGAL FUNCTION	The query message from the client has a function code that cannot be handled by the server.
02	ILLEGAL DATA ADDRESS*1	The query message from the client has a register address that cannot be handled by the server. (No parameter, parameter cannot be read, parameter cannot be written)
03	ILLEGAL DATA VALUE	The query message from the client has data that cannot be handled by the server. (Out of parameter write range, a mode is specified, or other error)

*1 An error response is not returned in the following cases.

- (a) Function code H03 (reading data of holding registers)

When the quantity of registers is specified as one or more and there are one or more holding registers from which data can be read.

- (b) Function code H10 (writing data to multiple holding registers)

When the quantity of registers is specified as one or more and there are one or more holding registers to which data can be written.

In other words, when function code H03 or H10 is used and multiple holding registers are accessed, an error response is not returned even if a nonexistent holding register or holding register that cannot be read or written from/to is accessed.

NOTE

- An error response is returned if none of the accessed holding registers exist. When an accessed holding register does not exist, the read value is 0 and the written data is invalid.

- Error detection of message data

The following errors are detected in message data from the client. The inverter output is not shut off even if an error is detected.

Error check items

Error item	Error description	Inverter operation
Parity error	The data received by the inverter is different from the specified parity (Pr.120 setting).	When this error occurs, Pr.343 is incremented by one. When this error occurs, the LF signal is output.
Framing error	The data received by the inverter is different from the stop bit length (Pr.119/Pr.120 setting).	
Overrun error	The next data has been sent by the client before the inverter completes receiving the preceding data.	
Message frame error	The data length of the message frame is checked, and an error is generated if the received data length is less than 4 bytes. When a receive buffer overflow occurs, an error is generated if a received message frame is addressed to the own station or broadcasted.	
CRC check error	An error is generated if the data in the message frame does not match the calculation result.	

NOTE

- The LF signal can be assigned to an output terminal by setting any of **Pr.190 to Pr.197 (Output terminal function selection)**. Changing the terminal assignment may affect other functions. Set parameters after confirming the function of each terminal.

◆ MODBUS register

- The following shows the MODBUS registers for system environment variables (read/write), monitor codes (read), parameters (read/write), fault history data (read/write), and model information monitor items (read).
- System environment variables

Register	Definition	Read/write	Remarks
40002	Inverter reset	Write	Any value
40003	Parameter clear	Write	Set H965A.
40004	All parameter clear	Write	Set H99AA.
40006	Parameter clear ^{*1}	Write	Set H5A96.
40007	All parameter clear ^{*1}	Write	Set HAA99.
40008	Inverter status / control input command (extended) ^{*2}	Read/write	Refer to the following.
40009	Inverter status / control input command ^{*2}	Read/write	Refer to the following.
40010	Operation mode / inverter setting ^{*3}	Read/write	Refer to the following.
40014	Set frequency (RAM value)	Read/write	(The display can be changed to the rotations per minute (machine speed) using Pr.37 and Pr.53 . Refer to the FR-E800 Instruction Manual (Function).)
40015	Set frequency (EEPROM value)	Write	

*1 Settings in the communication parameters are not cleared.

*2 The data is written as a control input command for writing. The data is read as the inverter status for reading.

*3 The data is written as an operation mode setting for writing. The data is read as the operation mode status for reading.

- Inverter status / control input command, and inverter status / control input command (extended)

Bit	Definition	
	Control input command	Inverter status
0	Stop command	RUN (Inverter running) ^{*2}
1	Forward rotation command	Forward running
2	Reverse rotation command	Reverse running
3	RH (High-speed operation command) ^{*1}	Up to frequency
4	RM (Middle-speed operation command) ^{*1}	Overload alarm
5	RL (Low-speed operation command) ^{*1}	0
6	JOG operation selection 2	FU (Output frequency detection) ^{*2}
7	Second function selection	ABC (Fault) ^{*2}
8	Terminal 4 input selection	ABC2 (0) ^{*2}
9	—	Safety monitor output 2 ^{*3}
10	MRS (Output stop) ^{*1}	0
11	—	0
12	RES (Inverter reset) ^{*1}	0
13	—	0
14	—	0
15	—	Fault occurrence

Bit	Definition	
	Control input command	Inverter status
0	NET X1 (—) ^{*1}	NET Y1 (0) ^{*2}
1	NET X2 (—) ^{*1}	NET Y2 (0) ^{*2}
2	NET X3 (—) ^{*1}	NET Y3 (0) ^{*2}
3	NET X4 (—) ^{*1}	NET Y4 (0) ^{*2}
4	NET X5 (—) ^{*1}	0
5	—	0
6	—	0
7	—	0
8	—	0
9	—	0
10	—	0
11	—	0
12	—	0
13	—	0
14	—	0
15	—	0

*1 The signal within parentheses () is the initial status. The function changes depending on the setting of **Pr.180 to Pr.189 (Input terminal function selection)**.

For details, refer to the description of **Pr.180 to Pr.189 (Input terminal function selection)** in the FR-E800 Instruction Manual (Function).

The signals assigned to the input terminals may be valid or invalid in the NET operation mode. (Refer to the FR-E800 Instruction Manual (Function).)

*2 The signal within parentheses () is the initial status. The function changes depending on the setting of **Pr.190 to Pr.197 (Output terminal function selection)**.

For details, refer to the description of **Pr.190 to Pr.197 (Output terminal function selection)** in the FR-E800 Instruction Manual (Function).

*3 Fixed to 0 when the FR-E8TR or the FR-E8TE7 is installed.

- Operation mode / inverter setting

Mode	Read value	Write value
EXT	H0000	H0010 ^{*1}
PU	H0001	H0011 ^{*1}
EXT JOG	H0002	—
PU JOG	H0003	—
NET	H0004	H0014
PU + EXT	H0005	—

*1 Writing is available depending on the **Pr.79 and Pr.340** settings. For details, refer to the FR-E800 Instruction Manual (Function). Restrictions in each operation mode conform with the computer link specification.

- Monitor code

For details of the register numbers and the monitor items, refer to the description of **Pr.52** in the FR-E800 Instruction Manual (Function).

- Parameters

Pr.	Register	Name	Read/write	Remarks
0 to 999	41000 to 41999	For details on parameter names, refer to the parameter list in the FR-E800 Instruction Manual (Function).	Read/write	The parameter number + 41000 is the register number.
C2 (902)	41902	Terminal 2 frequency setting bias frequency	Read/write	
C3 (902)	42092	Terminal 2 frequency setting bias (analog value)	Read/write	Analog value (%) set in C3 (902)
	43902	Terminal 2 frequency setting bias (terminal analog value)	Read	Analog value (%) of the voltage (current) applied to terminal 2
125 (903)	41903	Terminal 2 frequency setting gain frequency	Read/write	
C4 (903)	42093	Terminal 2 frequency setting gain (analog value)	Read/write	Analog value (%) set in C4 (903)
	43903	Terminal 2 frequency setting gain (terminal analog value)	Read	Analog value (%) of the voltage (current) applied to terminal 2
C5 (904)	41904	Terminal 4 frequency setting bias frequency	Read/write	
C6 (904)	42094	Terminal 4 frequency setting bias (analog value)	Read/write	Analog value (%) set in C6 (904)
	43904	Terminal 4 frequency setting bias (terminal analog value)	Read	Analog value (%) of the current (voltage) applied to terminal 4
126 (905)	41905	Terminal 4 frequency setting gain frequency	Read/write	
C7 (905)	42095	Terminal 4 frequency setting gain (analog value)	Read/write	Analog value (%) set in C7 (905)
	43905	Terminal 4 frequency setting gain (terminal analog value)	Read	Analog value (%) of the current (voltage) applied to terminal 4
C12 (917)	41917	Terminal 1 bias frequency (speed)	Read/write	Available only when the FR-E8AXY is installed.
C13 (917)	42107	Terminal 1 bias (speed) (analog value)	Read/write	Analog value (%) set in C13 (917) (Available only when the FR-E8AXY is installed.)
	43917	Terminal 1 bias (speed) (terminal analog value)	Read	Analog value (%) of the voltage applied to terminal 1 (Available only when the FR-E8AXY is installed.)
C14 (918)	41918	Terminal 1 gain frequency (speed)	Read/write	Available only when the FR-E8AXY is installed.
C15 (918)	42108	Terminal 1 gain (speed) (analog value)	Read/write	Analog value (%) set in C15 (918) (Available only when the FR-E8AXY is installed.)
	43918	Terminal 1 gain (speed) (terminal analog value)	Read	Analog value (%) of the voltage applied to terminal 1 (Available only when the FR-E8AXY is installed.)
C16 (919)	41919	Terminal 1 bias command (torque)	Read/write	Available only when the FR-E8AXY is installed.

Pr.	Register	Name	Read/write	Remarks
C17 (919)	42109	Terminal 1 bias (torque) (analog value)	Read/write	Analog value (%) set in C17 (919) (Available only when the FR-E8AXY is installed.)
	43919	Terminal 1 bias (torque) (terminal analog value)	Read	Analog value (%) of the voltage applied to terminal 1 (Available only when the FR-E8AXY is installed.)
C18 (920)	41920	Terminal 1 gain command (torque)	Read/write	Available only when the FR-E8AXY is installed.
C19 (920)	42110	Terminal 1 gain (torque) (analog value)	Read/write	Analog value (%) set in C19 (920) (Available only when the FR-E8AXY is installed.)
	43920	Terminal 1 gain (torque) (terminal analog value)	Read	Analog value (%) of the voltage applied to terminal 1 (Available only when the FR-E8AXY is installed.)
C38 (932)	41932	Terminal 4 bias command (torque)	Read/write	
C39 (932)	42122	Terminal 4 bias (torque) (analog value)	Read/write	Analog value (%) set in C39 (932)
	43932	Terminal 4 bias (torque) (terminal analog value)	Read	Analog value (%) of the current (voltage) applied to terminal 4
C40 (933)	41933	Terminal 4 gain command (torque)	Read/write	
C41 (933)	42123	Terminal 4 gain (torque) (analog value)	Read/write	Analog value (%) set in C41 (933)
	43933	Terminal 4 gain (torque) (terminal analog value)	Read	Analog value (%) of the current (voltage) applied to terminal 4
C42 (934)	41934	PID display bias coefficient	Read/write	
C43 (934)	42124	PID display bias analog value	Read/write	Analog value (%) set in C43 (934)
	43934	PID display bias analog value (terminal analog value)	Read	Analog value (%) of the current (voltage) applied to terminal 4
C44 (935)	41935	PID display gain coefficient	Read/write	
C45 (935)	42125	PID display gain analog value	Read/write	Analog value (%) set in C45 (935)
	43935	PID display gain analog value (terminal analog value)	Read	Analog value (%) of the current (voltage) applied to terminal 4
1000 to 1999	45000 to 45999	For details on parameter names, refer to the parameter list in the FR-E800 Instruction Manual (Function).	Read/write	The parameter number + 44000 is the register number.

- Fault history

Register	Definition	Read/write	Remarks
40501	Fault record 1	Read/write	Being 2 bytes in length, the data is stored as H00○○. Refer to the lowest 1 byte for the error code. (For details on error codes, refer to the FR-E800 Instruction Manual (Maintenance).) The fault history is batch-cleared by writing to register 40501. Set any value as data.
40502	Fault record 2	Read	
40503	Fault record 3	Read	
40504	Fault record 4	Read	
40505	Fault record 5	Read	
40506	Fault record 6	Read	
40507	Fault record 7	Read	
40508	Fault record 8	Read	
40509	Fault record 9	Read	
40510	Fault record 10	Read	

- Product profile

Register	Definition	Read/write	Remarks
44001	Model (1st and 2nd characters)	Read	The inverter model can be read in ASCII code. "H20" (blank code) is set for blank area. Example) FR-E820-1: H46, H52, H2D, H45, H38, H32, H30, H2D, H31, H20 ... H20
44002	Model (3rd and 4th characters)	Read	
44003	Model (5th and 6th characters)	Read	
44004	Model (7th and 8th characters)	Read	
44005	Model (9th and 10th characters)	Read	
44006	Model (11th and 12th characters)	Read	
44007	Model (13th and 14th characters)	Read	
44008	Model (15th and 16th characters)	Read	
44009	Model (17th and 18th characters)	Read	
44010	Model (19th and 20th characters)	Read	
44011	Capacity (1st and 2nd characters)	Read	The capacity in the inverter model can be read in ASCII code. Data is read in increments of 0.1 kW, and rounds down to 0.01 kW increments. "H20" (blank code) is set for blank area. Example) 0.75K: " 7" (H20, H20, H20, H20, H20, H37)
44012	Capacity (3rd and 4th characters)	Read	
44013	Capacity (5th and 6th characters)	Read	

NOTE

- When a 32-bit parameter setting or monitor item is read and the value to be read exceeds HFFFF, HFFFF is returned.
- The display can be changed from the frequency to rotations per minute (machine speed) using **Pr.53**. When the machine speed is displayed, the value is incremented by one.

◆ Pr.343 Communication error count

- The communication error occurrence count can be checked.

Parameter	Setting range	Minimum setting range	Initial value
343	(0 to 999) (Read-only)	1	0

NOTE

- The communication error count is temporarily stored in the RAM memory. The value is not stored in the EEPROM, and so is cleared to 0 when power is reset and the inverter is reset.

◆ Alarm (LF) signal output (communication error warning)

- During a communication error, the Alarm (LF) signal is output by open collector output. Assign the terminal to be used using any of **Pr.190 to Pr.197 (Output terminal function selection)**.

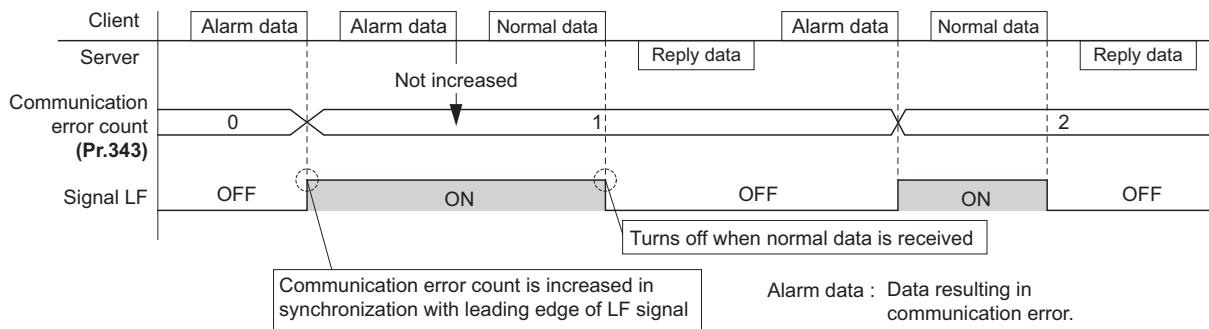

NOTE

- The LF signal can be assigned to an output terminal by setting **Pr.190 to Pr.197**. Changing the terminal assignment may affect other functions. Set parameters after confirming the function of each terminal.

◆ Signal loss detection (Pr.122)

- If a signal loss (communication stop) is detected between the inverter and computer as a result of a signal loss detection, a communication error (E.PUE) occurs and the inverter output will be shut off.
- When a signal loss is detected, the LF signal is output.
- When "9999" is set, the communication check (signal loss detection) will not be performed.
- The monitor items and parameter settings can be read via RS-485 communication when "0" is set, but a communication error (E.PUE) occurs instantly when the operation mode is switched to the one for the selected command interface (Network operation mode in the initial setting).
- Setting any value from 0.1 second to 999.8 seconds will enable signal loss detection. To make a signal loss detection, it is necessary to send data from the computer within the communication check time interval. (The inverter makes a communication check (clearing of communication check counter) regardless of the station number setting of the data sent from the client.)

- Communication check is started at the initial communication in the operation mode for the selected command interface (Network operation mode in the initial setting).

Example: Pr.122 = "0.1 to 999.8s"

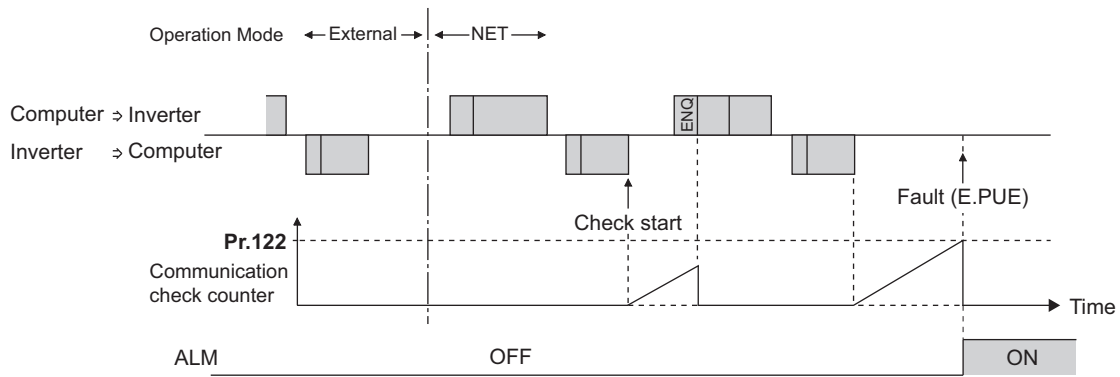

NOTE

- The operation at a communication error occurrence depends on the setting of **Pr.502 Stop mode selection at communication error**. (Refer to [page 282](#).)

3.6 BACnet MS/TP

Operation or parameter setting via communication is possible using the BACnet MS/TP protocol through the PU connector on the inverter.

To use BACnet MS/TP, set "2" in **Pr.549 Protocol selection**.

This function is not supported depending on the date of manufacture of the inverter. For details of specification changes, refer to [page 290](#).

Pr.	Name	Initial value ^{*1}		Setting range	Description
		Gr.1	Gr.2		
52 M100	Operation panel main monitor selection	0		0, 5 to 14, 17 to 20, 22 to 33, 35, 38, 40 to 42, 44, 45, 50 to 57, 61, 62, 64, 65, 67, 68, 81 to 84, 85 ^{*2} , 86 ^{*3} , 91, 97, 100	81: BACnet reception status 82: BACnet token pass counter (Displays the count of received token) 83: BACnet valid APDU counter (Displays the count of valid APDU detection) 84: BACnet communication error counter (Displays the count of communication error)
774 M101	Operation panel monitor selection 1	9999		1 to 3, 5 to 14, 17 to 20, 22 to 33, 35, 38, 40 to 42, 44, 45, 50 to 57, 61, 62, 64, 65, 67, 68, 81 to 84, 85 ^{*2} , 86 ^{*3} , 91, 97, 100, 9999	85: Terminal FM output level (Same display as Analog Output 0)
775 M102	Operation panel monitor selection 2				86: Terminal AM output level (Same display as Analog Output 1)
776 M103	Operation panel monitor selection 3				The count of the setting values "82" and "83" returns to "0" if the count exceeds "9999". The upper limit of the count of the setting value "84" is "9999".
117 N020	PU communication station number	0		0 to 127 ^{*4}	Set the inverter station number (node).
118 N021	PU communication speed	192		96, 192, 384, 576, 768, 1152 ^{*4*5}	Select the communication speed. The setting value × 100 equals the communication speed. For example, enter 96 to set the communication speed of 9600 bps.
122 N026	PU communication check time interval	0		0	RS-485 communication is enabled. However, the inverter output is shut off if the operation mode is changed to the one for the selected command interface.
				0.1 to 999.8 s	Set the interval of the communication check (signal loss detection) time. If a no-communication state persists for longer than the permissible time, the inverter output will be shut off.
				9999	No communication check (signal loss detection)
390 N054	% setting reference frequency	60 Hz	50 Hz	1 to 590 Hz	Set a reference frequency of the set frequency.
549 N000	Protocol selection	0		0	Mitsubishi inverter protocol (computer link)
				1	MODBUS RTU protocol
				2 ^{*6}	BACnet MS/TP protocol
726 N050	Auto Baudrate/Max Master	255		0 to 255	Auto baud rate (bit 7) 0: inactive, 1: active
					Max Master (bit 0 to bit 6) setting range: 0 to 127 Maximum address for master node
727 N051	Max Info Frames	1		1 to 255	Set the maximum number of frames that the inverter can transmit while it owns the token.
728 N052	Device instance number (Upper 3 digits)	0		0 to 419 (0 to 418)	Device identifier When the figure obtained by combining the Pr.728 and Pr.729 settings is not within "0 to 4194302", the setting is out of range.
729 N053	Device instance number (Lower 4 digits)	0		0 to 9999 (0 to 4302)	When Pr.728 = "419", the setting range of Pr.729 is "0 to 4302". When Pr.729 = "4303" or more, the setting range of Pr.728 is "0 to 418".

*1 Gr.1 and Gr.2 are the parameter initial value groups. (Refer to the FR-E800 Instruction Manual (Function).)

*2 The setting is available only for the FR-E800-1.

*3 The setting is available only for the FR-E800-4 and FR-E800-5.

*4 When a value outside the setting range is set, the inverter operates at the initial value.

*5 When the Auto baudrate is used, the communication speed is changed to the detected communication speed.

*6 When Pr.549 = "2 (BACnet MS/TP)", the parameter unit is not available.

NOTE

- Always reset the inverter after making the initial settings of the parameters. After changing the communication-related parameters, communication cannot be made until the inverter is reset.

◆ Communication specifications

- The specifications conform to the BACnet standard of physical medium EIA-485.

Item	Description
Physical medium	EIA-485 (RS-485)
Connection port	PU connector
Data transfer method	NRZ encoding
Baud rate	9600 bps, 19200 bps, 38400 bps, 57600 bps, 76800 bps, 115200 bps
Start bit	Fixed to 1 bit
Data length	Fixed to 8 bits
Parity bit	Fixed to none
Stop bit	Fixed to 1 bit
Network topology	Bus topology
Communication method	Token passing (token bus) Master-slave (This product is used as the master only.)
Communication protocol	MS/TP (master-slave/token passing LAN)
Maximum connection	255 (up to 32 for one segment, addition with a repeater available)
Node number	0 to 127
Master	0 to 127 (range available for the master)
Supported property of BACnet standard object type	Refer to page 265 .
Supported BIBBs (Annex K)	Refer to page 274 .
BACnet standardized device profile (Annex L)	Refer to page 274 .
Segmentation	Not supported
Device address binding	Not supported

NOTE

- This product is classified as a BACnet Application Specific Controller (B-ASC).
- This product is designed for multiple master network, therefore 2-wire type connection is supported.
- This product is a node with local bias resistors. Therefore at least one node must be a node with network bias resistors in the network configuration. Prepare a node with network bias resistors.

◆ BACnet reception status monitor (Pr.52)

- Set Pr.52 = "81" to monitor the BACnet communication status on the operation panel.

Monitor value	Status	Description	LF signal output
0	Idle	Never had BACnet communication	OFF
1	Automatic baud rate recognition	Automatic baud rate recognition. (Communication error during automatic baud rate recognition is not counted.)	OFF
2	Not joined the network	Waiting for a token to own node	OFF
10	Data to own node	Received a token to own node	OFF
11		Received a supported request to own node (including broadcasting)	OFF
12		Received an unsupported request to own node (including broadcasting)	OFF
20	Data to other node	Received a token to other nodes	OFF
30	Node separated	Separated from token passing after joined in it.	OFF
90	Fault data	Detected a communication error.	ON
91		Protocol error (LPDU, NPDU, APDU are not following the format regulations.)	ON

◆ Signal loss detection (Pr.122)

- If signal loss is detected between the inverter and computer, the communication error "E.PUE" will occur and the inverter output will be shut off.
- When a signal loss is detected, the LF signal is output.

- When "9999" is set, the communication check (signal loss detection) will not be performed.
- The monitor items and parameter settings can be read via RS-485 communication when "0" is set, but a communication error (E.PUE) occurs instantly when the operation mode is switched to the one for the selected command interface (Network operation mode in the initial setting).
- Setting any value from 0.1 second to 999.8 seconds will enable signal loss detection. To make a signal loss detection, it is necessary to send data from the computer within the communication check time interval. (The inverter makes a communication check (clearing of communication check counter) regardless of the station number setting of the data sent from the master).
- Communication check is started at the initial communication in the operation mode for the selected command interface (Network operation mode in the initial setting).

Example: Pr.122 = "0.1 to 999.8s"

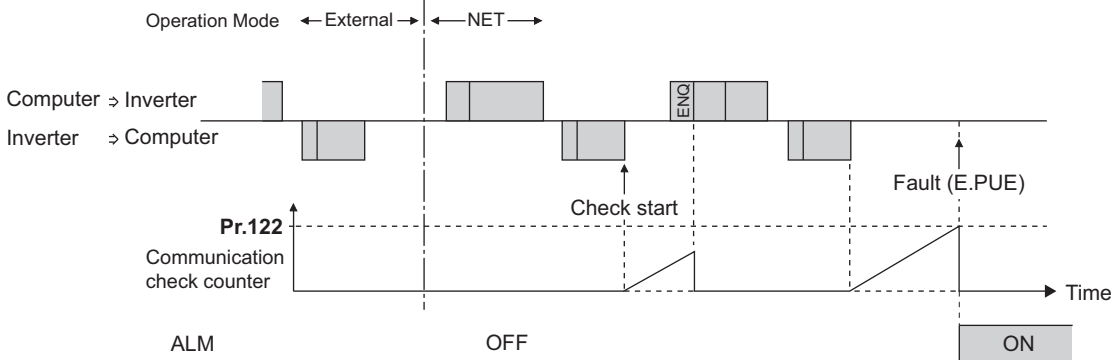

NOTE

- The operation at a communication error occurrence depends on the setting of **Pr.502 Stop mode selection at communication error**. (Refer to [page 282](#).)

◆ % setting reference frequency (Pr.390)

- Set a reference frequency of the set frequency. The setting value of **Pr.390 % setting reference frequency** is 100% reference. The reference to the frequency command is converted to the set frequency in the following formula.
 Set frequency = % setting reference frequency × Speed scale (Refer to [page 268](#).)

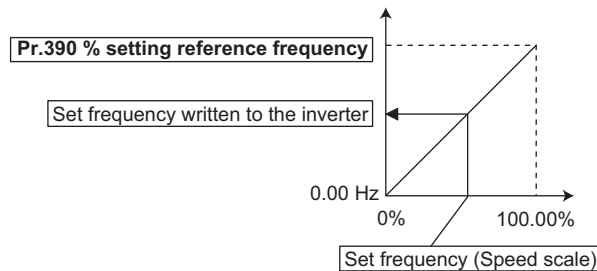

NOTE

- The % setting reference frequency cannot be set at less than the minimum frequency resolution of the inverter.
- The set frequency is written to RAM.
- The set frequency is applied at the writing of Speed scale. (The set frequency is not applied at the setting of **Pr.390**.)

◆ Automatic baud rate recognition (Pr.726 Auto Baudrate/Max Master)

- Automatic changing of baud rate is available with **Pr.726** setting. When **Pr.726** = "128 to 255", turn the power ON from OFF or reset the inverter to start automatic baud rate recognition.

Pr.726 setting	Operation
0 to 127	Automatic baud rate recognition is disabled. (The Pr.118 setting is used as the baud rate.)
128 to 255	The inverter monitors the data on the communication bus, and automatically switches the baud rate. The recognized baud rate is written to Pr.118 .

NOTE

- After the baud rate recognition, the recognized baud rate is written in EEPROM as the **Pr.118** setting regardless of the **Pr.342 Communication EEPROM write selection** setting.
- The BACnet status monitor displays "1" during automatic baud rate recognition.
- The communication error monitor count is not performed during automatic baud rate recognition.
- During automatic baud rate recognition, the inverter does not transmit data, but only accepts data.
- The baud rate switching operation cannot be finished if the inverter is not connected to the communication bus. (BACnet protocol will not be established.)
- The baud rate switching operation cannot be finished if the inverter is continuously receiving abnormal data during automatic baud rate switching. (BACnet protocol will not be established.)

◆ Supported property of BACnet standard object type

R: Read only, W: Read/Write (Commandable values not supported), C: Read/Write (Commandable values supported)

Property	Object support condition							
	Analog Input	Analog Output	Analog Value	Binary Input	Binary Output	Binary Value	Device	Network Port
APDU Length								R
APDU Timeout							R	
Application Software Version							R	
Changes Pending								R
Database Revision							R	
Device Address Binding							R	
Event State	R		R	R	R	R		
Firmware Revision							R	
Link Speed								R
MAC Address								R
Max APDU Length Accepted							R	
Max Info Frames							W	W
Max Master							W	W
Model Name							R	
Network Number								W
Network Number Quality								R
Network Type								R
Number of APDU Retries							R	
Object Identifier	R		R	R	R	R	R	R
Object List							R	
Object Name	R		R	R	R	R	R	R
Object Type	R		R	R	R	R	R	R
Out Of Service	R		R	R	R	R		R
Polarity				R	R			
Present Value	R		C ^{*1}	R	C	C ^{*1}		
Priority Array			R ^{*2}		R	R ^{*2}		
Protocol Level								R
Protocol Object Types Supported							R	
Protocol Revision							R	
Protocol Services Supported							R	
Protocol Version							R	
Reliability								R
Relinquish Default			R ^{*2}		R	R ^{*2}		
Segmentation Supported							R	
Status Flags	R		R	R	R	R		R
System Status							R	
Unit	R		R					
Vendor Identifier							R	
Vendor Name							R	
Property List	R	R	R	R	R	R	R	R
Current Command Priority		R			R			

*1 This property is commandable for some instances of this object. Otherwise it is read/write.

*2 This property is supported only for instances of this object where the Present Value property is commandable.

◆ Details of the supported properties

- The details of the supported properties are as follows.

Property	Details
APDU Length	Shows the maximum number of octets. Fixed to 50 octets for the FR-E800.
APDU Timeout	Shows the send retry interval (ms) when there is no reception confirmation response to the APDU request.
Application Software Version	Shows the inverter firmware version.
Changes Pending	If the property value whose change is to be reflected at a reset is changed, TRUE (1) is returned. FALSE (0) is returned after the status is initialized by a reset.
Database Revision	Always 0.
Device Address Binding	No data.
Event State	Shows the event state of the related object. Fixed to NORMAL (0) for the FR-E800.
Firmware Revision	Shows the firmware level.
Link Speed	Shows the communication speed in the unit of bit/s. The Pr.118 setting value × 100 equals the communication speed.
MAC Address	Shows the MAC address of the network port. The Pr.117 setting value is used for the MAC address. For example, the MAC address is 7F when Pr.117 = "127".
Max APDU Length Accepted	Shows the maximum APDU length.
Max Info Frames	Shows the maximum number of frames that the inverter can transmit while it owns the token. When a value is written, it is reflected to the Pr.727 setting.
Max Master	Shows the maximum address for master node. When a value is written, it is reflected to the Pr.726 setting.
Model Name	Shows the model of the BACnet device.
Network Number	Shows the network number. Fixed to 0 for the FR-E800. If a value other than "0" is written, an error code VALUE_OUT_OF_RANGE (37) will be returned.
Network Number Quality	Shows the quality of the network port number. Fixed to UNKNOWN (0) for the FR-E800.
Network Type	Shows the communication method of the network. Fixed to MSTP (2) for the FR-E800.
Number of APDU Retries	Shows the maximum number of APDU send retries.
Object Identifier	Shows the unique numeric code to identify the object.
Object List	Shows the object identifier list.
Object Name	Shows the object name.
Object Type	Analog input: ANALOG_INPUT (0) Analog output: ANALOG_OUTPUT (1) Analog value: ANALOG_VALUE (2) Binary input: BINARY_INPUT (3) Binary output: BINARY_OUTPUT (4) Binary value: BINARY_VALUE (5) Device: DEVICE (8) Network port: NETWORK_PORT (56)
Out Of Service	If the Present Value property is not changed or if the change is not applied, TRUE (1) is returned. FALSE (0) is returned in other cases.
Polarity	REVERSE (1) is returned when the binary output is negative logic. Fixed to NORMAL (0) for the binary input.
Present Value	Shows the present value of each object identifier.
Priority Array	Values to be written to the objects supporting the commandable values are stored. Values are initialized at the power-ON or inverter reset.
Protocol Level	Shows the protocol level. Fixed to BACNET_APPLICATION (2) for the FR-E800.
Protocol Object Types Supported	The bit is 1 for the supported objects or 0 for the other objects.
Protocol Revision	Shows the revision of the compliant BACnet standard.
Protocol Services Supported	The bit is 1 for the supported services or 0 for the other services.
Protocol Version	Shows the version of the compliant BACnet standard.
Reliability	Shows the reliability of the network port. Fixed to no-fault-detected (0) for the FR-E800.
Relinquish Default	Shows the default value to be applied when no data is stored in the Priority Array property.
Segmentation Supported	Shows whether to support segmentation of messages at sending/receiving. Fixed to NO_SEGMENTATION (3) for the FR-E800.

Property	Details
Status Flags	Always 0.
System Status	Shows the current physical and logical status of the device.
Unit	Uses engineering units as the measurement unit.
Vendor Identifier	Shows 16-bit vendor identification code assigned by ASHRAE.
Vendor Name	Mitsubishi Electric Corporation
Property List	Shows the property identifier list.
Current Command Priority	Shows the currently active priority.

◆ Supported BACnet object

• ANALOG INPUT

Object identifier	Object name	Present value access type ^{*1}	Description	Unit
1	Terminal 2	R	Represents actual input voltage (or input current) of terminal 2. (The range varies depending on the Pr.73 and Pr.267 settings. 0 to 10 V (0% to 100%), 0 to 5 V (0% to 100%), 0 to 20 mA (0% to 100%))	percent (98)
2	Terminal 4	R	Represents actual input current (or input voltage) of terminal 4. (The range varies depending on the Pr.73 and Pr.267 settings. 2 to 10 V (0% to 100%), 1 to 5 V (0% to 100%), 4 to 20 mA (0% to 100%))	percent (98)

*1 R: Read only, W: Read/Write (Commandable values not supported), C: Read/Write (Commandable values supported)

• ANALOG OUTPUT

Object identifier	Object name	Present value access type ^{*1}	Description	Unit
0 ^{*2}	Terminal FM	C	Controls actual output current level of terminal FM. Control is available when Pr.54 FM terminal function selection = "85" ^{*4} . (Setting range: 0% to 200%)	percent (98)
1 ^{*3}	Terminal AM	C	Controls actual output voltage level of terminal AM. Control is available when Pr.158 AM terminal function selection = "86" ^{*4} . (Setting range: -200% to 200%)	percent (98)

*1 R: Read only, W: Read/Write (Commandable values not supported), C: Read/Write (Commandable values supported)

Values written to the objects that support the commandable values are stored in the Priority Array, even when "Write Access Denied" is returned due to inconsistency of the writing requirements such as the operating mode, on condition that the values are written within the setting range.

*2 The setting is available only for the FR-E800-1.

*3 The setting is available only for the FR-E800-4 and FR-E800-5.

*4 Available regardless of the operation mode, operation command source, and speed command source.

• ANALOG VALUE

Object identifier	Object name	Present value access type ^{*1}	Description	Unit
1	Output frequency ^{*2}	R	Represents the output frequency value.	hertz (27)
2	Output current	R	Represents the output current value.	amperes (3)
3	Output voltage	R	Represents the output voltage value.	volts (5)
6	Running speed ^{*2}	R	Represents the running speed value.	revolution-per-minute (104)
8	Converter output voltage	R	Represents the converter output voltage value.	volts (5)
14	Output power	R	Represents the output power value.	kilowatts (48)

Object identifier	Object name	Present value access type ^{*1}	Description	Unit
17	Load meter	R	Represents the load meter value.	percent (98)
20	Cumulative energization time	R	Represents the cumulative energization time value.	hours (71)
23	Actual operation time	R	Represents the actual operation time value.	hours (71)
25	Cumulative power	R	Represents the cumulative power value.	kilowatt-hours (19)
52	PID set point	R	Represents the PID set point.	no-units (95)
54	PID deviation	R	Represents the PID deviation. (Minus display is available with reference to 0%, in 0.1% increment.)	no-units (95)
67	PID measured value2	R	Represents the PID measurement 2.	no-units (95)
200	Alarm history 1	R	Represents the latest fault record (fault record 1).	no-units (95)
201	Alarm history 2	R	Represents the second latest fault (fault record 2).	no-units (95)
202	Alarm history 3	R	Represents the third latest fault (fault record 3).	no-units (95)
203	Alarm history 4	R	Represents the fourth latest fault (fault record 4).	no-units (95)
300	Speed scale ^{*3}	C	Controls the ratio of the frequency command. (Setting range: 0.00 to 100.00) (Refer to page 264.)	percent (98)
310	PID set point CMD ^{*3}	C	Set the PID action set point. <ul style="list-style-type: none"> This object is the set point during dancer control if Pr.128 = "40 to 43" and Pr.609 = "4". (Setting range: 0.00 to 100.00)^{*5} This object is the set point during PID operation if Pr.128 = "60 or 61". (Setting range: 0.00 to 100.00)^{*4} This object is the set point during PID operation if Pr.128 = "1000 or 1001" and Pr.609 = "4". (Setting range: 0.00 to 100.00)^{*4*5} This object is the set point during PID operation if Pr.128 = "2000 or 2001" (not applied to the frequency) and Pr.609 = "4". (Setting range: 0.00 to 100.00)^{*4*5} 	no-units (95)
311	PID measured value CMD ^{*3}	C	Set the PID measured value. <ul style="list-style-type: none"> This object is the measured value during dancer control if Pr.128 = "40 to 43" and Pr.610 = "4". (Setting range: 0.00 to 100.00) This object is the measured value during PID operation if Pr.128 = "60 or 61". (Setting range: 0.00 to 100.00)^{*4} This object is the measured value during PID operation if Pr.128 = "1000 or 1001" and Pr.610 = "4". (Setting range: 0.00 to 100.00)^{*4} This object is the measured value during PID operation if Pr.128 = "2000 or 2001" (not applied to the frequency) and Pr.610 = "4". (Setting range: 0.00 to 100.00)^{*4} 	no-units (95)
312	PID deviation CMD ^{*3}	C	Set the PID deviation. (0.01 increments) <ul style="list-style-type: none"> This object is the deviation during PID operation if Pr.128 = "50 or 51". (Setting range: -100.00 to 100.00) This object is the deviation during PID operation if Pr.128 = "1010 or 1011" and Pr.609 = "4". (Setting range: -100.00 to 100.00) This object is the deviation during PID operation if Pr.128 = "2010 or 2011" (not applied to the frequency) and Pr.609 = "4". (Setting range: -100.00 to 100.00) 	percent (98)
398	Mailbox parameter	W	Access to the properties which are not defined as objects are available. (Refer to page 270.)	no-units (95)
399	Mailbox value	W		no-units (95)
10007	Acceleration time	W	Set Pr.7 Acceleration time.	seconds (73)
10008	Deceleration time	W	Set Pr.8 Deceleration time.	seconds (73)

- *1 R: Read only, W: Read/Write (Commandable values not supported), C: Read/Write (Commandable values supported)
 Values written to the objects that support the commandable values are stored in the Priority Array, even when "Write Access Denied" is returned due to inconsistency of the writing requirements such as the operating mode, on condition that the values are written within the setting range.
- *2 The **Pr.37 and Pr.53** settings are invalid.
- *3 If communication speed command source is other than NET, the setting value can be written, but not to be applied.
- *4 When both **C42 and C44** ≠ "9999", the setting range is from the smaller coefficient to the larger coefficient of **C42 and C44**. Depending on the setting, the writing value and the reading value may not be the same at the minimum digit.
- *5 When **Pr.133** ≠ "9999", the **Pr.133** setting is valid.

• BINARY INPUT

Object identifier	Object name	Present value access type ^{*1}	Description (0: inactive, 1: active)
0	Terminal STF	R	Represents actual input of terminal STF.
1	Terminal STR	R	Represents actual input of terminal STR.
4	Terminal RL	R	Represents actual input of terminal RL.
5	Terminal RM	R	Represents actual input of terminal RM.
6	Terminal RH	R	Represents actual input of terminal RH.
8	Terminal MRS	R	Represents actual input of terminal MRS.
10	Terminal RES	R	Represents actual input of terminal RES.
100	Terminal RUN	R	Represents actual output of terminal RUN.
104	Terminal FU	R	Represents actual output of terminal FU.
105	Terminal ABC	R	Represents actual output of terminals A, B, and C.
107 ^{*2}	Terminal SO	R	Represents actual output of terminal SO.

*1 R: Read only, W: Read/Write (Commandable values not supported), C: Read/Write (Commandable values supported)

*2 No function is assigned when the FR-E8TR or the FR-E8TE7 is installed.

• BINARY OUTPUT

Object identifier	Object name	Present value access type ^{*1}	Description (0: inactive, 1: active)
0	Terminal RUN CMD	C	Represents actual output of terminal RUN. Control is available when Pr.190 RUN terminal function selection = "82 or 182" ^{*2} .
4	Terminal FU CMD	C	Controls actual output of terminal FU. Control is available when Pr.191 FU terminal function selection = "82 or 182" ^{*2} .
5	Terminal ABC CMD	C	Controls actual output of terminals A, B, and C. Control is available when Pr.192 ABC terminal function selection = "82 or 182" ^{*2} .

*1 R: Read only, W: Read/Write (Commandable values not supported), C: Read/Write (Commandable values supported)

Values written to the objects that support the commandable values are stored in the Priority Array, even when "Write Access Denied" is returned due to inconsistency of the writing requirements such as the operating mode, on condition that the values are written within the setting range.

*2 Available regardless of the operation mode, operation command source, and speed command source.

• BINARY VALUE

Object identifier	Object name	Present value access type ^{*1}	Description
0	Inverter running	R	Represents the Inverter running (RUN) signal status.
11	Inverter operation ready	R	Represents the Inverter operation ready (RY) signal status.
98	Alarm output	R	Represents the Alarm (LF) signal status.
99	Fault output	R	Represents the Fault (ALM) signal status.
200	Inverter running reverse	R	Represents inverter reverse running status.
302	Control input instruction RL	C	Controls the function assigned to terminal RL. Setting 1 in this object turns ON the signal assigned to Pr.180 RL terminal function selection .
303	Control input instruction RM	C	Controls the function assigned to terminal RM. Setting 1 in this object turns ON the signal assigned to Pr.181 RM terminal function selection .
304	Control input instruction RH	C	Controls the function assigned to terminal RH. Setting 1 in this object turns ON the signal assigned to Pr.182 RH terminal function selection .
306	Control input instruction MRS	C	Controls the function assigned to terminal MRS. Setting 1 in this object turns ON the signal assigned to Pr.183 MRS terminal function selection .
308	Control input instruction RES ^{*2}	C	Controls the function assigned to terminal RES. Setting 1 in this object turns ON the signal assigned to Pr.184 RES terminal function selection .
400	Run/Stop	C	Controls the start/stop command. The start command is written after the Speed scale is applied. ^{*3} 1: Start 0: Stop
401	Forward/Reverse	C	Controls the forward/reverse rotation. ^{*3} 1: Reverse rotation 0: Forward rotation
402	Fault reset	C	Clears fault output status. (Release of an inverter fault without inverter reset is available.)

- *1 R: Read only, W: Read/Write (Commandable values not supported), C: Read/Write (Commandable values supported)
Values written to the objects that support the commandable values are stored in the Priority Array, even when "Write Access Denied" is returned due to inconsistency of the writing requirements such as the operating mode, on condition that the values are written within the setting range.
- *2 The RES signal cannot be controlled over a network. Therefore, the control input instruction RES is invalid in the initial status. To use the control input instruction RES, change the signal with **Pr.184 RES terminal function selection**. (Refer to the FR-E800 Instruction Manual (Function).) (Reset is available with ReinitializeDevice.)
- *3 If communication operation command source is other than NET, the setting value can be written, but not to be applied.

• DEVICE

Object identifier	Object name	Description
0 to 4194302	Model information # device instance number	Reads the device status or changes the setting. Device instance number: Pr.728 × 10000 + Pr.729
4194303 ^{*1}		

- *1 Available only for Read Property Service.

• NETWORK PORT

Object identifier	Object name	Description
0	BACnetMSTP on EIA-485	Reads the status of the PU connector or changes the setting.
4194303 ^{*1}	Access is attempted as the object identifier of the port which receives the request.	

- *1 Available only for Read Property Service.

◆ Mailbox parameter / Mailbox value (BACnet registers)

- Access to the properties which are not defined as objects are available by using "Mailbox parameter" and "Mailbox value".
- To read a property, write the register of the intended property to "Mailbox parameter", and then read "Mailbox value". To write a property, write the register of the intended property to "Mailbox parameter", and then write a value to "Mailbox value".

- System environment variables

Register	Definition	Read/write	Remarks
40010	Operation mode / inverter setting	Read/write	The data is written as an operation mode setting for writing. The data is read as the operation mode status for reading.

[Operation mode / inverter setting]

Mode	Read value	Write value
EXT	H0000	H0010 ^{*1}
PU	H0001	H0011 ^{*1}
EXT JOG	H0002	—
PU JOG	H0003	—
NET	H0004	H0014
PU + EXT	H0005	—

*1 Writing is available depending on the settings of **Pr.79** and **Pr.340**. For details, refer to the FR-E800 Instruction Manual (Function). Restrictions in each operation mode conform with the computer link specification.

- Monitor code

For details of the register numbers and the monitor items, refer to the description of **Pr.52** in the FR-E800 Instruction Manual (Function).

- Parameter

Pr.	Register	Name	Read/write	Remarks
0 to 999	41000 to 41999	For details on parameter names, refer to the parameter list in the FR-E800 Instruction Manual (Function).	Read/write	The parameter number + 41000 is the register number.
C2 (902)	41902	Terminal 2 frequency setting bias frequency	Read/write	
C3 (902)	42092	Terminal 2 frequency setting bias (analog value)	Read/write	Analog value (%) set in C3 (902)
	43902	Terminal 2 frequency setting bias (terminal analog value)	Read	Analog value (%) of the voltage (current) applied to terminal 2
125 (903)	41903	Terminal 2 frequency setting gain frequency	Read/write	
C4 (903)	42093	Terminal 2 frequency setting gain (analog value)	Read/write	Analog value (%) set in C4 (903)
	43903	Terminal 2 frequency setting gain (terminal analog value)	Read	Analog value (%) of the voltage (current) applied to terminal 2
C5 (904)	41904	Terminal 4 frequency setting bias frequency	Read/write	
C6 (904)	42094	Terminal 4 frequency setting bias (analog value)	Read/write	Analog value (%) set in C6 (904)
	43904	Terminal 4 frequency setting bias (terminal analog value)	Read	Analog value (%) of the current (voltage) applied to terminal 4
126 (905)	41905	Terminal 4 frequency setting gain frequency	Read/write	
C7 (905)	42095	Terminal 4 frequency setting gain (analog value)	Read/write	Analog value (%) set in C7 (905)
	43905	Terminal 4 frequency setting gain (terminal analog value)	Read	Analog value (%) of the current (voltage) applied to terminal 4
C12 (917)	41917	Terminal 1 bias frequency (speed)	Read/write	Available only when the FR-E8AXY is installed.
C13 (917)	42107	Terminal 1 bias (speed) (analog value)	Read/write	Analog value (%) set in C13 (917) (Available only when the FR-E8AXY is installed.)
	43917	Terminal 1 bias (speed) (terminal analog value)	Read	Analog value (%) of the voltage applied to terminal 1 (Available only when the FR-E8AXY is installed.)
C14 (918)	41918	Terminal 1 gain frequency (speed)	Read/write	Available only when the FR-E8AXY is installed.

Pr.	Register	Name	Read/write	Remarks
C15 (918)	42108	Terminal 1 gain (speed) (analog value)	Read/write	Analog value (%) set in C15 (918) (Available only when the FR-E8AXY is installed.)
	43918	Terminal 1 gain (speed) (terminal analog value)	Read	Analog value (%) of the voltage applied to terminal 1 (Available only when the FR-E8AXY is installed.)
C16 (919)	41919	Terminal 1 bias command (torque)	Read/write	Available only when the FR-E8AXY is installed.
C17 (919)	42109	Terminal 1 bias (torque) (analog value)	Read/write	Analog value (%) set in C17 (919) (Available only when the FR-E8AXY is installed.)
	43919	Terminal 1 bias (torque) (terminal analog value)	Read	Analog value (%) of the voltage applied to terminal 1 (Available only when the FR-E8AXY is installed.)
C18 (920)	41920	Terminal 1 gain command (torque)	Read/write	Available only when the FR-E8AXY is installed.
C19 (920)	42110	Terminal 1 gain (torque) (analog value)	Read/write	Analog value (%) set in C19 (920) (Available only when the FR-E8AXY is installed.)
	43920	Terminal 1 gain (torque) (terminal analog value)	Read	Analog value (%) of the voltage applied to terminal 1 (Available only when the FR-E8AXY is installed.)
C38 (932)	41932	Terminal 4 bias command (torque)	Read/write	
C39 (932)	42122	Terminal 4 bias (torque) (analog value)	Read/write	Analog value (%) set in C39 (932)
	43932	Terminal 4 bias (torque) (terminal analog value)	Read	Analog value (%) of the current (voltage) applied to terminal 4
C40 (933)	41933	Terminal 4 gain command (torque)	Read/write	
C41 (933)	42123	Terminal 4 gain (torque) (analog value)	Read/write	Analog value (%) set in C41 (933)
	43933	Terminal 4 gain (torque) (terminal analog value)	Read	Analog value (%) of the current (voltage) applied to terminal 4
C42 (934)	41934	PID display bias coefficient	Read/write	
C43 (934)	42124	PID display bias analog value	Read/write	Analog value (%) set in C43 (934)
	43934	PID display bias analog value (terminal analog value)	Read	Analog value (%) of the current (voltage) applied to terminal 4
C44 (935)	41935	PID display gain coefficient	Read/write	
C45 (935)	42125	PID display gain analog value	Read/write	Analog value (%) set in C45 (935)
	43935	PID display gain analog value (terminal analog value)	Read	Analog value (%) of the current (voltage) applied to terminal 4
1000 to 1999	45000 to 45999	For details on parameter names, refer to the parameter list in the FR-E800 Instruction Manual (Function).	Read/write	The parameter number + 44000 is the register number.

- Fault history

Register	Definition	Read/write	Remarks
40501	Fault record 1	Read/write	<p>Being 2 bytes in length, the data is stored as H00○○. Refer to the lowest 1 byte for the error code. (For details on error codes, refer to the list of fault displays in the FR-E800 Instruction Manual (Maintenance).)</p> <p>The fault history is batch-cleared by writing to register 40501.</p> <p>Set any value as data.</p>
40502	Fault record 2	Read	
40503	Fault record 3	Read	
40504	Fault record 4	Read	
40505	Fault record 5	Read	
40506	Fault record 6	Read	
40507	Fault record 7	Read	
40508	Fault record 8	Read	
40509	Fault record 9	Read	
40510	Fault record 10	Read	

- Product profile

Register	Definition	Read/write	Remarks
44001	Model (1st and 2nd characters)	Read	The model name can be read in ASCII code. "H20" (blank code) is set for blank area. Example) FR-E840-1 (FM type): H46, H52, H2D, H45, H38, H34, H30, H2D, H31, H20 ... H20
44002	Model (3rd and 4th characters)	Read	
44003	Model (5th and 6th characters)	Read	
44004	Model (7th and 8th characters)	Read	
44005	Model (9th and 10th characters)	Read	
44006	Model (11th and 12th characters)	Read	
44007	Model (13th and 14th characters)	Read	
44008	Model (15th and 16th characters)	Read	
44009	Model (17th and 18th characters)	Read	
44010	Model (19th and 20th characters)	Read	
44011	Capacity (1st and 2nd characters)	Read	The inverter rated capacity can be read in ASCII code. Data read is displayed in increments of 0.1 kW (rounded down to one decimal place). "H20" (blank code) is set for blank area. Example) 0.75K: " 7" (H20, H20, H20, H20, H20, H37)
44012	Capacity (3rd and 4th characters)	Read	
44013	Capacity (5th and 6th characters)	Read	

 **NOTE**

- When a 32-bit parameter setting or monitor item is read and the value to be read exceeds HFFFF, HFFFF is returned.

◆ ANNEX A - PROTOCOL IMPLEMENTATION CONFORMANCE STATEMENT (NORMATIVE)

(This annex is part of this Standard and is required for its use.)

BACnet Protocol Implementation Conformance Statement

Date: 1st Sep 2021

Vendor Name: Mitsubishi Electric Corporation

Product Name: Inverter

Product Model Number: (FR-E800 series)

Application Software Version: 8650F

Firmware Revision: 1.00

BACnet Protocol Revision: 19

Product Description:

BACnet Standardized Device Profile (Annex L):

- BACnet Cross-Domain Advanced Operator Workstation (B-XAWS)
- BACnet Advanced Operator Workstation (B-AWS)
- BACnet Operator Workstation (B-OWS)
- BACnet Operator Display (B-OD)
- BACnet Advanced Life Safety Workstation (B-ALSWS)
- BACnet Life Safety Workstation (B-LSWS)
- BACnet Life Safety Annunciator Panel (B-LSAP)
- BACnet Advanced Access Control Workstation (B-AACWS)
- BACnet Access Control Workstation (B-ACWS)
- BACnet Access Control Security Display (B-ACSD)
- BACnet Building Controller (B-BC)
- BACnet Advanced Application Controller (B-AAC)
- BACnet Application Specific Controller (B-ASC)
- BACnet Smart Sensor (B-SS)
- BACnet Smart Actuator (B-SA)
- BACnet Advanced Life Safety Controller (B-ALSC)
- BACnet Life Safety Controller (B-LSC)
- BACnet Advanced Access Control Controller (B-AACC)
- BACnet Access Control Controller (B-ACC)
- BACnet Router (B-RTR)
- BACnet Gateway (B-GW)
- BACnet Broadcast Management Device (B-BBMD)
- BACnet Access Control Door Controller (B-ACDC)
- BACnet Access Control Credential Reader (B-ACCR)
- BACnet General (B-GENERAL)

List all BACnet Interoperability Building Blocks Supported (Annex K):

DS-RP-B, DS-WP-B, DM-DDB-B, DM-DOB-B, DM-DCC-B, DM-RD-B

Segmentation Capability:

- Able to transmit segmented messages Window Size _____
- Able to receive segmented messages Window Size _____

Standard Object Types Supported:

An object type is supported if it may be present in the device. For each standard Object Type supported provide the following data:

- 1.** Whether objects of this type are dynamically creatable using the CreateObject service
- 2.** Whether objects of this type are dynamically deletable using the DeleteObject service
- 3.** List of the optional properties supported
- 4.** List of all properties that are writable where not otherwise required by this standard
- 5.** List of all properties that are conditionally writable where not otherwise required by this standard
- 6.** List of proprietary properties and for each its property identifier, datatype, and meaning
- 7.** List of any property range restrictions

Dynamic object creation and deletion is not supported.

To check the object types supported by the standard model, refer to [page 267](#).

Data Link Layer Options:

- ARCNET (ATA 878.1), 2.5 Mb. (Clause 8)
- ARCNET (ATA 878.1), EIA-485 (Clause 8), baud rate(s) _____
- BACnet IP, (Annex J)
- BACnet IP, (Annex J), BACnet Broadcast Management Device (BBMD)
- BACnet IP, (Annex J), Network Address Translation (NAT Traversal)
- BACnet IPv6, (Annex U)
- BACnet IPv6, (Annex U), BACnet Broadcast Management Device (BBMD)
- BACnet/ZigBee (Annex O) _____
- ISO 8802-3, Ethernet (Clause 7)
- MS/TP master (Clause 9), baud rate(s): 9600, 19200, 38400, 57600, 76800, 115200
- MS/TP slave (Clause 9), baud rate(s): _____
- Point-To-Point, EIA 232 (Clause 10), baud rate(s): _____
- Point-To-Point, modem, (Clause 10), baud rate(s): _____
- Other: _____

Device Address Binding:

Is static device binding supported? (This is currently necessary for two-way communication with MS/TP slaves and certain other devices.) Yes No

Networking Options:

- Router, Clause 6 - List all routing configurations, e.g., ARCNET-Ethernet, Ethernet-MS/TP, etc.
- Annex H, BACnet Tunneling Router over IP

Character Sets Supported:

Indicating support for multiple character sets does not imply that they can all be supported simultaneously.

- ISO 10646 (UTF-8)
- IBM™/Microsoft™ DBCS
- ISO 8859-1
- ISO 10646 (UCS-2)
- ISO 10646 (UCS-4)
- JIS X 0208

Gateway Options:

If this product is a communication gateway, describe the types of non-BACnet equipment/networks(s) that the gateway supports:

If this product is a communication gateway which presents a network of virtual BACnet devices, a separate PICS shall be provided that describes the functionality of the virtual BACnet devices. That PICS shall describe a superset of the functionality of all types of virtual BACnet devices that can be presented by the gateway.

Network Security Options:

- Non-secure Device - is capable of operating without BACnet Network Security
- Secure Device - is capable of using BACnet Network Security (NS-SD BIBB)
- Multiple Application-Specific Keys
- Supports encryption (NS-ED BIBB)
- Key Server (NS-KS BIBB)

CHAPTER 4 Other Communication Options

4.1	USB device communication	278
4.2	Automatic connection with GOT	280

4 Other Communication Options

4.1 USB device communication

A personal computer and an inverter can be connected with a USB cable. Setup of the inverter can be easily performed with FR Configurator2.

The inverter can be connected easily to a personal computer by a USB cable.

Pr.	Name	Initial value	Setting range	Description
547 N040 ^{*1}	USB communication station number	0	0 to 31	Specify the inverter station number.
548 N041 ^{*1}	USB communication check time interval	9999	0	USB communication is possible, however the inverter output is shut off (E.USB) when the mode changes to the PU operation mode.
			0.1 to 999.8 s	Set the communication check time interval. If a no-communication state persists for longer than the permissible time, the inverter output is shut off (E.USB).
			9999	No communication check

*1 The changed value is applied after the next power-ON or inverter reset.

◆ USB communication specifications

Interface	Conforms to USB 1.1 (USB 2.0 full speed)
Transmission speed	12 Mbps
Wiring length	Maximum 5 m
Connector	USB mini B connector (receptacle)
Power supply	Self-powered ^{*1}
Recommended USB cable	MR-J3USBCBL3M (cable length 3 m)

*1 USB bus power connection is available. The maximum SCCR is 500 mA. A PU connector cannot be used during USB bus power connection.

- Standard model, Ethernet model, and safety communication model

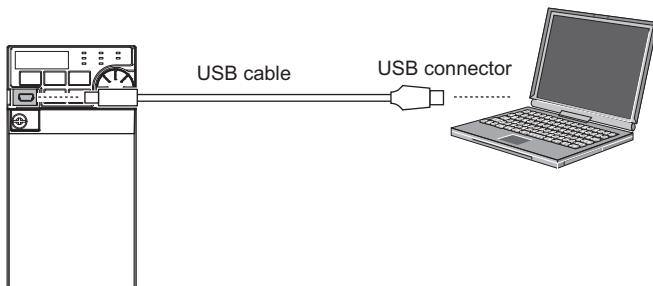

- IP67 model

Remove the small resin cap, then connect a USB cable. The protective structure is IP00 when the cap is removed. When the USB cable is removed, always install the cap. (Tightening torque: 1 N·m)

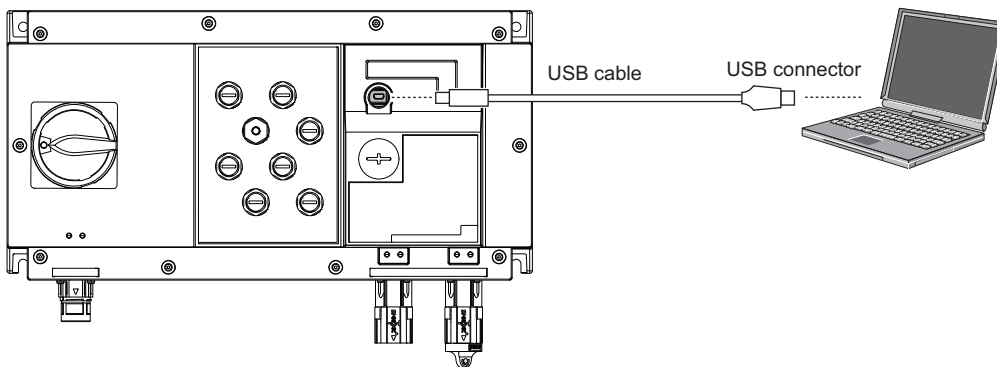

- At the initial setting (**Pr.551 PU mode operation command source selection** = "9999"), communication with FR Configurator2 can be made in the PU operation mode simply by connecting a USB cable. To fix the command source to the USB connector in the PU operation mode, set "3" in **Pr.551**.
- Parameter setting and monitoring can be performed by using FR Configurator2. For details, refer to the Instruction Manual of FR Configurator2.

 **NOTE**

- Operation is not guaranteed when multiple inverters are connected using a USB hub.
-

4.2 Automatic connection with GOT

When the automatic connection is enabled in the GOT2000 series, the inverter can communicate with the GOT2000 series with only setting the station number and connecting the GOT. This eliminates the need for setting each communication parameter separately.

Pr.	Name	Initial value	Setting range	Description
117 N020	PU communication station number	0	0 to 31 ^{*1}	Specify the inverter station number. The inverter station number setting is required when multiple inverters are connected to one GOT (PU connector communication).

*1 Setting range when **Pr.549 Protocol selection** = "0" (Mitsubishi inverter protocol). The setting range is "0 to 247" when **Pr.549** = "1" (MODBUS RTU), and "0 to 127" when **Pr.549** = "2" (BACnet MS/TP). When a value outside the setting range is set, the inverter operates at the initial value.

◆ Automatic connection system configuration

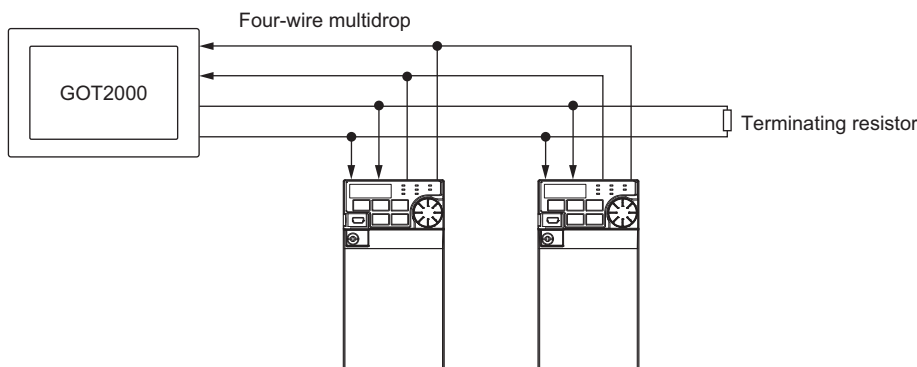

◆ GOT2000 series automatic recognition

- Set the station number (**Pr.117**) of the inverter before the automatic recognition is performed.
- When the GOT2000 series is connected, the parameters required for the GOT connection are automatically changed by setting the automatic recognition on the GOT2000 series side.
- Connect all the stations of inverters with GOT before the automatic recognition is performed. The inverter newly added after automatic recognition will not be recognized automatically. (When an inverter is added, perform the initial setting in **Pr.999 Automatic parameter setting** or set the automatic recognition on the GOT side again.)

Automatic change item	Automatic change parameter	Setting value after change
Communication speed	Pr.118	Depending on the setting of the connected device on the GOT side.
Data length / stop bit	Pr.119	
Parity	Pr.120	
Time delay setting	Pr.123	
CR/LF selection	Pr.124	
Number of communication retries	Pr.121	9999 (fixed)
Communication check time interval	Pr.122	9999 (fixed)
Protocol selection	Pr.549	0 (fixed to Mitsubishi inverter protocol)

NOTE

- If the automatic recognition cannot be performed, initial setting in **Pr.999** is required.
- For connection to a device other than the GOT2000 series, initial setting in **Pr.999** is required.
- For details, refer to the GOT2000 Series Connection Manual (Mitsubishi Product).

CHAPTER 5 Common Settings

5 Common Settings

Set the action when the inverter is performing operation via communication.

Set the action at fault occurrence or at reading/writing of parameters.

Pr.	Name	Initial value	Setting range	Description
342 N001	Communication EEPROM write selection	0	0	Parameter values written by communication are written to the EEPROM and RAM. When the index of inverter parameter is read via Ethernet communication (acyclic communication), the EEPROM value is read.
			1	Parameter values written by communication are written to the RAM. When the index of inverter parameter is read via Ethernet communication (acyclic communication), the RAM value is read.
349 N010 ^{*1}	Communication reset selection	0	0	Enables the error reset function in any operation mode.
			1	Error reset is enabled in the Network operation mode.
500 N011 ^{*2}	Communication error execution waiting time	0	0 to 999.8 s	Set the time from when the communication line error occurs until the inverter starts the operation for the communication error (when a communication option is used).
501 N012 ^{*2}	Communication error occurrence count display	0	0	Displays the communication error occurrence count (when a communication option is used).
502 N013	Stop mode selection at communication error	0	0 to 2, 6	Select the operation at a communication error occurrence.
779 N014	Operation frequency during communication error	9999	0 to 590 Hz	Set the frequency for the operation when a communication error occurs.
			9999	Operation continues at the same frequency before the communication error.

*1 For the standard model, the setting is available only when a communication option is installed.

*2 The setting is available only when a communication option is installed. For the IP67 model, the setting is not available as plug-in options are not available.

◆ Communication EEPROM write selection (Pr.342)

- When parameter write is performed via the inverter PU connector, Ethernet connector, USB communication, or a communication option, the parameters storage device can be changed to "RAM only" from "EEPROM and RAM". Use this function if parameter settings are changed frequently.
- When changing the parameter values frequently, set "1" in **Pr.342 Communication EEPROM write selection** to write them to the RAM only. The life of the EEPROM will be shorter if parameter write is performed frequently with the setting unchanged from "0 (initial value)" (EEPROM write).
- When the index of inverter parameter is read via Ethernet communication (acyclic communication) while **Pr.342** = "0 (initial value)", the EEPROM value is read. When **Pr.342** = "1", the RAM value is read.

NOTE

- Turning OFF the inverter's power supply clears the modified parameter settings when **Pr.342** = "1 (write only to RAM)". Therefore, the parameter settings last stored to EEPROM applies at next power-ON.
- The parameter setting written in the RAM cannot be checked on the operation panel. (The values displayed on the operation panel are the ones stored in the EEPROM.)

◆ Operation selection at a communication error (Pr.502, Pr.779)

- For communication via the PU connector, Ethernet connector, or a communication option, operation at a communication error can be selected. The operation is active under the Network operation mode.
- Select the stop operation at the retry count excess (**Pr.121**, enabled only when the Mitsubishi inverter protocol is selected) or at a signal loss detection (**Pr.122**) during the RS-485 communication.
- The operation at a communication error can be selected with **Pr.502** when **Pr.1431 Ethernet signal loss detection function selection** = "3" or **Pr.1432 Ethernet communication check time interval** ≠ "9999" during Ethernet communication.

Fault type	Pr.502 setting	At fault occurrence			At fault removal		
		Operation	Display	Fault (ALM) signal	Operation	Display	Fault (ALM) signal
PU disconnection, Ethernet communication fault, communication option fault	0 (initial value)	Output shutoff	"E.PUE", "E.EHR", "E.OP1"	ON	Output stop status continues.	"E.PUE", "E.EHR", "E.OP1"	ON
	1	Output to decelerate and stop the motor.	"E.PUE", "E.EHR", "E.OP1" after stop	ON after stop			
	2			OFF	Restart ^{*1}	Normal	OFF
	6	Operation continues at the frequency set in Pr.779 . ^{*2*3}	"CF" warning	OFF	Normal	Normal	OFF
Option fault (when a communication option is used)	0	Output shutoff	"E. 1"	ON	Output stop status continues.	"E. 1"	ON
	1, 2	Output to decelerate and stop the motor.	"E. 1" after stop	ON after stop			
	6	Operation continues at the frequency set in Pr.779 . ^{*2*3}	"CF" warning	OFF	Operation continues at the frequency set in Pr.779 .	"CF" warning	OFF

*1 When the communication error is removed during deceleration, the motor re-accelerates. During position control, the motor does not re-accelerate even when the communication error is removed during deceleration.

*2 When the frequency command interface is switched to the one other than NET during operation, the frequency command given from an external device can be made valid.

During position control, the operation is continued to the target position. When the communication operation command source is changed to the External mode and the LX signal is not input via an external input terminal, the inverter output is shut off.

*3 During torque control, the **Pr.779** setting becomes invalid when **Pr.807 Speed limit selection** = "1". In this case, operation continues at the frequency set in **Pr.808 Speed limit** or **Pr.809 Reverse-side speed limit**.

- When a communication error is detected during communication through the PU connector or a communication option, the Alarm (LF) signal is output to an output terminal of the inverter. (When an option fault occurs, the LF signal is output only when "6" is set in **Pr.502**.)
- When a communication error is detected during communication via the Ethernet connector while **Pr.1431 Ethernet signal loss detection function selection** = "2 or 3", the Alarm (LF) signal is output to an output terminal of the inverter.

NOTE

- To use the LF signal, set "98" (positive logic) or "198" (negative logic) in any of **Pr.190 to Pr.197 (Output terminal function selection)** to assign the function to an output terminal.

- The following charts show operations when a communication line error occurs.

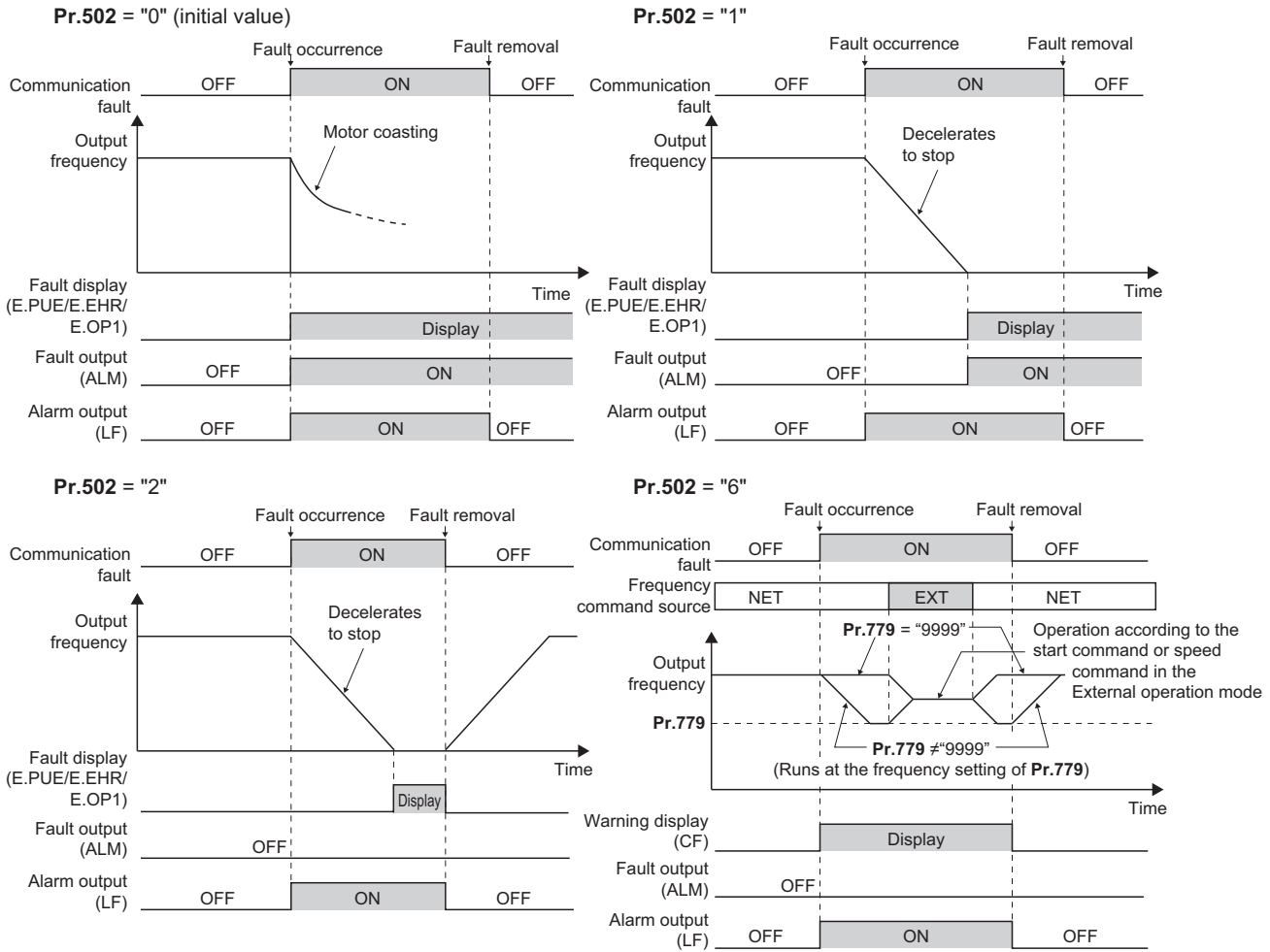

NOTE

- When the **Pr.1431** setting is changed to a value other than "3" and the **Pr.1457** setting is changed to a value other than "9999" after the operation defined by the **Pr.502** setting starts during Ethernet communication, the operation will be changed according to the settings of **Pr.1431** and **Pr.1457**.
- When the switchover mode (**Pr.79 Operation mode selection = "6"**) is set, the operation can be switched between NET and External during operation using the External/NET operation switchover (X66) signal. (Refer to the FR-E800 Instruction Manual (Function).)

- The following charts show operations when a communication option fault occurs.

Pr.502 = "0 (initial value)"

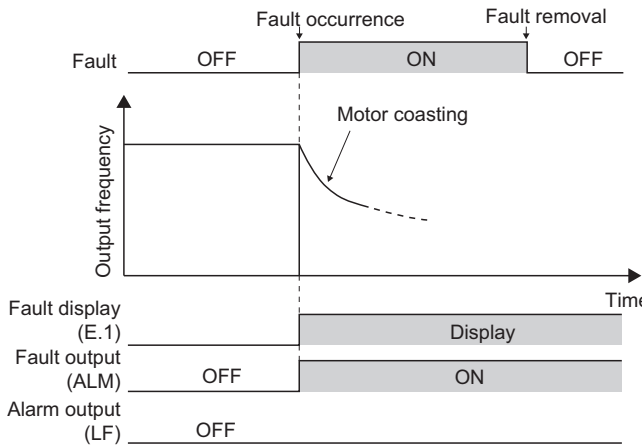

Pr.502 = "1 or 2"

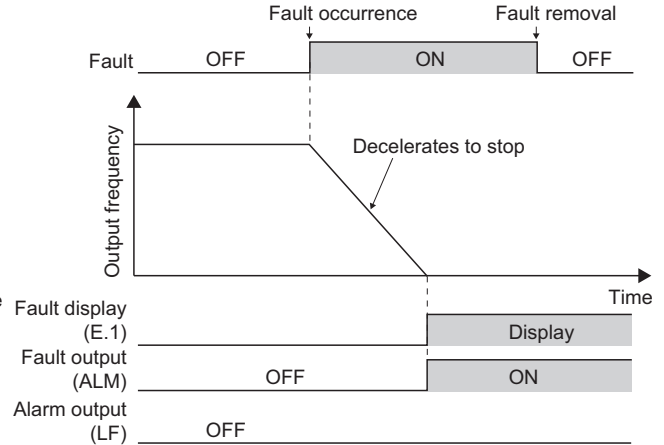

Pr.502 = "6"

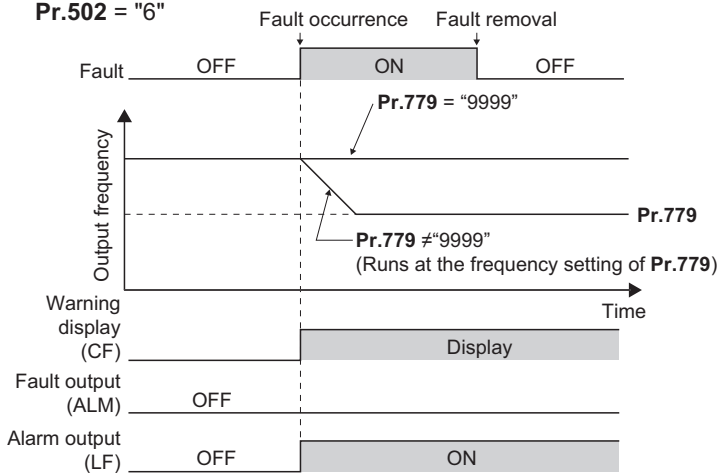

NOTE

- When a communication option is used, the protective function [E.OP1 (fault data: HA1)] is activated at error occurrences on the communication line. The protective function [E.1 (fault data: HF1)] is activated at error occurrences in the communication circuit inside the option.
- Fault output indicates the Fault (ALM) signal and an alarm bit output.
- When the fault output is set enabled, fault records are stored in the fault history. (A fault record is written to the fault history at a fault output.)
- When the fault output is not enabled, a fault record is overwritten to the fault history temporarily but not stored.
- After the fault is removed, the fault indication goes back to normal indication on the monitor, and the fault history goes back to the previous status.
- When **Pr.502 = "1 or 2"**, the normal deceleration time setting (settings like **Pr.8**, **Pr.44**, and **Pr.45**) is applied as the deceleration time. The **Pr.464** or **Pr.1223** deceleration time setting, whichever is smaller, is applied for position control.
- If a communication line error occurs, then the error is removed during deceleration while **Pr.502 = "2"**, the motor re-accelerates from that point. (During position control, the motor does not re-accelerate even when the communication error is removed during deceleration.) The operation command and the speed command before the fault occurred will be applied for restarting. The normal acceleration time setting (such as **Pr.7/Pr.44** setting) is applied for restart. (Acceleration does not restart when a communication option fault occurs.)
- The **Pr.502** and **Pr.779** settings are valid when communication is performed via the PU connector, Ethernet connector, or a communication option.
- These parameters are valid under the Network operation mode. When performing communication through the PU connector, set **Pr.551 PU mode operation command source selection** ≠ "2".
- Pr.502** is valid for the device that has the command source under the Network operation mode. When an error occurs for communication through the PU connector or the Ethernet connector while **Pr.550 = "9999 (initial value)"** and a communication option is installed, **Pr.502** becomes invalid.
- If the communication error setting is disabled with **Pr.121 = "9999"** or **Pr.122 = "9999"** while **Pr.502 = "6"**, the inverter does not operate with the frequency set in **Pr.779** when a communication error occurs.

⚠ CAUTION

- When **Pr.502** = "6" and a communication line error (PU disconnection, Ethernet communication fault, communication option fault) occurs, or a communication option fault occurs, the operation continues. When setting "6" in **Pr.502**, provide a safety stop countermeasure other than via communication. For example, input a signal through an external terminal (RES, MRS, or X92) or press the PU stop on the operation panel.

◆ Waiting time setting from the communication line error occurrence to the communication error activation (Pr.500)

- When a communication option is used, use **Pr.500 Communication error execution waiting time** to set the time from when the communication line error occurs until the inverter starts the operation for the communication error. For the IP67 model, the function is invalid as plug-in options are not available.
- When a communication line error occurs and lasts longer than the time set in **Pr.500**, it is recognized as a communication error. If the communication returns to normal within the time, it is not recognized as a communication error, and the operation continues.

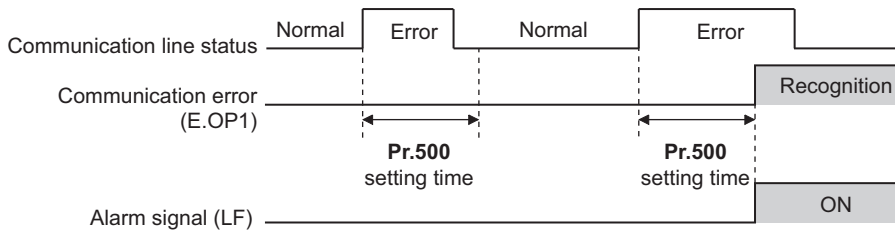

- Operation from the error occurrence until the **Pr.500** setting time elapses

Fault type	Pr.502 setting	Operation	Display	Fault (ALM) signal
PU disconnection, Ethernet communication fault, communication option fault	0	Operation continues.*1	Normal*1	OFF*1
	1			
	2			
	6			
Option fault (when a communication option is used)	0	Output shutoff	"E. 1"	ON
	1, 2	Output to decelerate and stop the motor	"E. 1" after stop	ON after stop
	6	Operation continues at the frequency set in Pr.779 . *2*3	"CF" warning	OFF

*1 When the communication returns to normal within the time period set in **Pr.500**, the protective function (E.OP1) is not activated.

*2 When the frequency command interface is switched to the one other than NET during operation, the frequency command given from an external device can be made valid.

During position control, the operation is continued to the target position. When the communication operation command source is changed to the External mode and the LX signal is not input via an external input terminal, the inverter output is shut off.

*3 During torque control, the **Pr.779** setting becomes invalid when **Pr.807 Speed limit selection** = "1". In this case, operation continues at the frequency set in **Pr.808 Speed limit** or **Pr.809 Reverse-side speed limit**.

◆ Displaying and clearing the communication error count (Pr.501)

- When a communication option is used, the cumulative count of communication error occurrences can be displayed. Write "0" to clear this cumulative count. For the IP67 model, the function is invalid as plug-in options are not available.
- When a communication line error occurs, the setting of **Pr.501 Communication error occurrence count display** increases by one.
- The cumulative count of communication error occurrences is counted from 0 to 65535. When the count exceeds 65535, the displayed value is cleared and the counting starts over from 0 again.

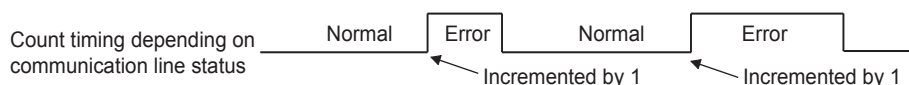

NOTE

- Communication error count is temporarily stored in the RAM memory. The error count is stored in EEPROM only once per hour. If power reset or inverter reset is performed, **Pr.501** setting will be the one that is last stored to EEPROM depending on the reset timing.

◆ Error reset operation selection at inverter fault (Pr.349)

- An error reset command from a communication option can be invalidated in the External operation mode or the PU operation mode.

Pr.349 setting	Description
0 (initial value)	Error reset is enabled independently of operation mode.
1	Error reset is enabled in the Network operation mode.

◆ Operation mode switching and communication startup mode (Pr.79, Pr.340)

- Check the following before switching the operation mode.
The inverter is at a stop.
Both the STF and STR signals are off.
The **Pr.79 Operation mode selection** setting is correct. (Check the setting on the operation panel of the inverter.) (Refer to the FR-E800 Instruction Manual (Function).)
- The operation mode at power ON and at restoration from instantaneous power failure can be selected. Set a value other than "0" in **Pr.340 Communication startup mode selection** to select the Network operation mode. (Refer to the FR-E800 Instruction Manual (Function).)
- After the inverter starts up in the Network operation mode, parameter write can be commanded via the network.

NOTE

- The changed value in **Pr.340** is applied after the next power-ON or inverter reset.
- The **Pr.340** setting can be changed on the operation panel in any operation mode.
- When setting a value other than "0" in **Pr.340**, make sure that the communication settings of the inverter are correct.

MEMO

CHAPTER 6 Appendix

6.1	How to check specification changes	290
-----	--	-----

6 Appendix

Appendix provides the reference information for use of this product.

Refer to the information as required.

6.1 How to check specification changes

Check the SERIAL number indicated on the inverter rating plate or packaging. For how to read the SERIAL number, refer to [page 9](#).

The inverter firmware can be updated by using Firmware Update Tool of FR Configurator2. The functions added due to specification changes are available.

For details on firmware update, refer to the FR Configurator2 Instruction Manual.

6.1.1 Details of specification changes

◆ Number of connectable units on the CC-Link IE Field Network Basic

Number of connectable units	SERIAL
Master: 1 Remote: up to 16 stations (16 stations × 1 group)	□□ 204 ○○○○○○ or earlier
Master: 1 Remote: up to 64 stations (16 stations × 4 groups)	□□ 205 ○○○○○○ or later

◆ Functions available for the inverters manufactured in May 2020 or later

- Firmware version: 1 or later

Item	Details
Mitsubishi Electric geared motor	GM-□
Plug-in option	FR-A8ND E kit, FR-A8NP E-kit
Stand-alone option	Parameter unit (FR-PU07), LCD operation panel (FR-LU08)
Added parameters	Pr.1499, P.E107 (Pr.75)
Changed parameter setting range	<ul style="list-style-type: none"> • Setting value "13" added for Pr.52, Pr.54, Pr.158, Pr.774 to Pr.776, Pr.992, Pr.1027 to Pr.1034 • Setting values "1800 and 1803" added for Pr.71 and Pr.450 (for 200/400 V class only) • Setting values "10000 to 10003, and 10014 to 10017" added for Pr.75 (for the safety communication model only)

◆ Functions available for the inverters manufactured in August 2020 or later

- Firmware version: 2 or later

Item	Details
Mitsubishi Electric Vector control dedicated motor (SF-V5RU (1500 r/min series))	The SF-V5RU 1.5 to 5.5 kW motors can be driven by the FR-E820-0110(2.2K) to 0330(7.5K) inverters. The SF-V5RUH 1.5 to 5.5 kW motors can be driven by the FR-E840-0060(2.2K) to 0170(7.5K) inverters.
Mitsubishi Electric high-performance energy-saving motor with encoder	SF-PR-SC
Mitsubishi Electric inverter-driven geared motor for encoder feedback control	GM-DZ, GM-DP
Plug-in option	FR-A8AP E kit
EtherNet/IP communication specifications	Access to the parameters, monitor data, and terminals is available. Inverter Configuration Object (64h) <ul style="list-style-type: none"> • Inverter Parameters (12288 to 16383) • Monitor Data (16384 to 20479) • Inverter Control Parameters (20480 to 24575)
PROFINET communication specifications	Access to the parameters, monitor data, and terminals is available. <ul style="list-style-type: none"> • Inverter Parameters (12288 to 16383) • Monitor Data (16384 to 20479) • Inverter Control Parameters (20480 to 24575)
Added parameters	Pr.284, Pr.359, Pr.367, Pr.368, Pr.369, Pr.376, Pr.422, Pr.552, Pr.600 to Pr.604, Pr.607, Pr.608, Pr.690, Pr.692 to Pr.696, Pr.802, Pr.823, Pr.828, Pr.833, Pr.840 to Pr.848, Pr.854, Pr.873, Pr.877 to Pr.881, P.A107 (Pr.285)
Changed parameter setting range	<ul style="list-style-type: none"> • Setting value "8888" added for Pr.11 • Setting values "19 and 35" added for Pr.52, Pr.774 to Pr.776, Pr.992, and Pr.1027 to Pr.1034 • Setting values "30 and 33" added for Pr.71 and Pr.450 • Setting values "13, 23, 42, 43, and 74" added for Pr.178 to Pr.189 • Setting values "30 to 33, and 130 to 133" added for Pr.190 to Pr.196, and Pr.313 to Pr.319 • Setting values "30 to 33" added for Pr.320 to Pr.322 • Setting values "0 to 2, and 9" added for Pr.800 • Setting value "2" added for Pr.850 • Setting value "6" added for Pr.858
Added faults	<ul style="list-style-type: none"> • Signal loss detection (E.ECT) • Brake sequence fault (E.MB1 to E.MB3)

◆ Functions available for the inverters manufactured in January 2021 or later

- Firmware version: 3 or later

Item	Details	Related manuals
Position control (Vector control)	Position control (Vector control) is supported for induction motors. • Pr.420, Pr.421, Pr.423, Pr.425 to Pr.427, Pr.430, Pr.446, Pr.464 to Pr.478, Pr.510, Pr.511, Pr.538, Pr.698, Pr.1222, Pr.1223, Pr.1225 to Pr.1227, Pr.1229 to Pr.1231, Pr.1233 to Pr.1235, Pr.1237 to Pr.1239, Pr.1241 to Pr.1243, Pr.1245 to Pr.1247, Pr.1249, Pr.1282, Pr.1283, Pr.1285, Pr.1286, Pr.1289, Pr.1290, Pr.1292 to Pr.1297.	Connection/ Function/ Communication/ Maintenance
	Position control is available. • Setting values "3 to 5" added for Pr.800	
	Signals for position control can be assigned to I/O terminals. • Setting values "76, and 87 to 89" added for Pr.178 to Pr.189 • Setting values "24, 36, 38, 56, 60 to 63, 84, 124, 136, 138, 156, 160 to 163, and 184" added for Pr.190 to Pr.196 and Pr.313 to Pr.319 • Setting values "24, 36, 38, 56, 60 to 63, and 84" added for Pr.320 to Pr.322	
	Monitoring during position control is available (multifunction monitor). • Setting values "26 to 31, and 65" added for Pr.52, Pr.774 to Pr.776, and Pr.992 • Setting value "65" added for Pr.54 and Pr.158 • Setting values "65, 222 to 227, and 229" added for Pr.1027 to Pr.1034	
	The following warnings are added: LP (Stroke limit warning), HP1 (Home position return setting error), and HP2 (Home position return uncompleted)	
	The following faults are added: E.OD (Excessive position fault) and E.OA (acceleration error).	
CC-Link IE TSN communication specifications	User defined cyclic communication is supported. • Setting values "38 and 138" of Pr.544 are available for remote registers.	Function/ Communication
EtherNet/IP communication specifications	User defined cyclic communication is supported. • "Configurable" is added for the connections of Class 1 communication (I/O Message communication) (Instances 100 and 150).	Communication
PROFINET communication specifications	User defined cyclic communication is supported. • Telegram 102 is added for Process Data (Cyclic Data Exchange).	Communication
MODBUS/TCP communication specifications	CiA402 drive profile (24642 to 24644, 24646, 24648, 24649, and 26623) is added for MODBUS registers.	Communication
PTC thermistor	Motor overheat protection by the motor's built-in PTC thermistor is supported. • Pr.561 and Pr.1016 are added. • Setting value "64" of Pr.52, Pr.774 to Pr.776, Pr.992, Pr.1027 to Pr.1034 is available (multifunction monitor). • E.PTC (PTC thermistor operation) is added.	Connection/ Function/ Maintenance
Backup/restore function	Inverter parameters and the data used in the PLC function of inverter can be backed up and restored. • RD (Backup in progress) and WR (Restoration in progress) indications are added.	Communication/ Maintenance
Increased magnetic excitation deceleration	Added functions • Pr.660 to Pr.662 are added.	Function
Optimum excitation control	The control can be enabled under Advanced magnetic flux vector control.	Function
PLC function	The structured text (ST) language is supported, and jump commands are supported.	PLC Function Programming Manual
Capacity	200 V class: 11K to 22K are added. 400 V class: 11K to 22K are added.	Connection/ Function/ Communication/ Maintenance
Parameters	Pr.375 added User Defined Cyclic Communication Input/Output Mapping parameters (Pr.1318 to Pr.1343) added	Function/ Communication

◆ Functions available for the inverters manufactured in May 2021 or later

- Firmware version: 5 or later

Item	Details	Related manuals
PM motor (MM-GKR 0.4kW and 0.75kW, and EM-A 5.5kW and 7.5kW)	Applied motor setting • Setting values "540 and 1140" (200 V class) added for Pr.71 and Pr.450	Connection/ Function/ Communication/ Maintenance
	Parameter initial setting • Setting values "3024, 3044, 3124, and 3144" (200 V class) added for Pr.998	
	Position control (Vector control) is supported for PM motors (MM-GKR and EM-A). Control mode setting • Setting values "13 and 14" added for Pr.451 and Pr.800	
Orientation control	Added parameters • Pr.350 to Pr.358, Pr.361 to Pr.366, Pr.393, Pr.396 to Pr.399	Function/ Communication/ Maintenance
	Setting values • Setting value "22" added for Pr.52 • Setting value "22" added for Pr.178 to Pr.189 • Setting values "27, 28, 127, and 128" added for Pr.190 to Pr.196 • Setting values "27, 28, 127, and 128" added for Pr.313 to Pr.319 • Setting values "27 and 28" added for Pr.320 to Pr.322 • Setting value "22" added for Pr.774 to Pr.776 • Setting value "22" added for Pr.992 • Setting value "22" added for Pr.1027 to Pr.1034	
EtherCAT communication specifications	The FR-E800-EPC models are added.	Connection/ Function/ Communication/ Maintenance
	Added parameter • Pr.1305	
Emergency drive (except for the E800-SCE inverters)	Added parameters • Pr.136, Pr.139, Pr.514, Pr.515, Pr.523, Pr.524, and Pr.1013	Connection/ Function/ Maintenance
	Setting values • Setting value "68" added for Pr.52 • Setting value "84" added for Pr.178 to Pr.189 • Setting values "18, 19, 65, 66, 165, and 166" added for Pr.190 to Pr.196 • Setting values "18, 19, 65, 66, 165, and 166" added for Pr.313 to Pr.319 • Setting values "18, 19, 65, and 66" added for Pr.320 to Pr.322 • Setting value "68" added for Pr.774 to Pr.776 • Setting value "68" added for Pr.992 • Setting value "68" added for Pr.1027 to Pr.1034	
	ED (Emergency drive) warning added	
Ethernet communication specifications	Simple positioning using CiA402 drive profile Added parameter • Pr.1220 Setting values • Setting values added for Pr.1320 to Pr.1329 [E800-(SC)EPA][E800-(SC)EPB] "24672, 24689, 24698, 24703, 24705, 24707, 24708, 24719, 24721, and 24728 to 24730" [E800-EPC] "12288 to 13787, 20488, 20489, 24642, 24646, 24648 to 24650, 24672, 24677 to 24680, 24689, 24698, 24702, 24703, 24705, 24707 to 24709, 24719, 24721, 24728 to 24730, 24831, and 9999" • Setting values added for Pr.1330 to Pr.1343 [E800-(SC)EPA][E800-(SC)EPB] "20992, 24639, 24643, 24644, 24673 to 24676, 24692, 24695, 24820, 24826, 24828, and 25858" [E800-EPC] "12288 to 13787, 16384 to 16483, 20488, 20489, 20981 to 20990, 20992, 24639, 24643, 24644, 24673 to 24676, 24692, 24695, 24820, 24826, 24828, 25858, and 9999"	Communication
	User defined cyclic communication specifications Added parameters • Pr.1389 to Pr.1398	
	Ethernet relay operation at reset selection Added parameter • Pr.1386	
Parameters	Parameters added for the second functions • Pr.1298 and Pr.1299	Function

◆ Functions available for the inverters manufactured in September 2021 or later

- Firmware version: 6 or later

Item	Details	Related manuals
BACnet MS/TP communication specifications	Added parameters • Pr.726 and Pr.727	Function/ Communication
	Setting values • Setting values "81, 82, and 84 to 86" added for Pr.52, Pr.774 to Pr.776, and Pr.1027 to Pr.1034 • Setting values "81 to 86" added for Pr.992 • Setting value "85" added for Pr.54 • Setting value "86" added for Pr.158 • Setting values "82 and 182" added for Pr.190 and Pr.191 • Setting value "2" added for Pr.549	

◆ Functions available for the inverters manufactured in December 2021 or later

- Firmware version: 7 or later

Item	Details	Related manuals
Cumulative pulse monitoring	Added parameters • Pr.635, Pr.636, and Pr.638	Function
	Setting values • Setting values "71 and 72" added for Pr.52, Pr.774 to Pr.776, Pr.992, and Pr.1027 to Pr.1034 • Setting value "52" added for Pr.178 to Pr.189	
24 V external power supply operation	Plug-in option FR-E8DS E kit is available.	Function/ Maintenance/ FR-E8DS E Kit Instruction Manual
	Setting values • Setting values "68 and 168" added for Pr.190 to Pr.196 and Pr.313 to Pr.319 • Setting value "68" added for Pr.320 to Pr.322	
	Operation panel indication "EV" (24 V external power supply operation) is added.	
Internal storage device status indication	Added parameter • Pr.890	Function/ Maintenance
	E.PE6 (Internal storage device fault) fault added	
MM-GKR motor capacity	0.1 kW and 0.2 kW are added.	Connection/ Function
Environmental impact diagnosis function	Cor (Corrosion warning) warning added	Maintenance

◆ Functions available for the inverters manufactured in May 2022 or later

- Firmware version: 9 or later

Item	Details	Related manuals
EM-A motor capacity	200 V class: 0.75 kW to 3.7 kW are added. 400 V class: 3.7 kW and 5.5 kW are added.	Connection/ Function
Anti-sway control	Added parameters • Pr.1072 to Pr.1079	Function
CC-Link IE TSN communication specifications	Added parameter • Pr.1210	Function/ Communication
EtherNet/IP communication specifications	Instance 21216 (Speed scale (numerator)) and instance 21217 (Speed scale (denominator)) are added for Inverter Configuration Object (64h)	Communication

◆ Functions available for the inverters manufactured in October 2022 or later

- Firmware version: 11 or later

Item	Details	Related manuals
Inverter capacity	100 V class: 0.1K to 0.75K are added.	Connection/ Function/ Communication/ Maintenance

◆ Functions available for the inverters manufactured in November 2022 or later

- Firmware version: 11 or later

Item	Details	Related manuals
EM-A motor capacity	200 V class: 0.1 kW to 0.4 kW are added. 400 V class: 2.2 kW is added.	Connection/ Function
Position accuracy compensation gain tuning	Added parameters • Pr.979 to Pr.981	Function
	Setting values • Setting value "301" added for Pr.96	
Anti-sway control function	Setting values • Setting value "54" added for Pr.178 to Pr.189	Function
BACnet/IP and BACnet MS/TP communication specifications	Network Port Object is added.	Communication
PROFINET communication specifications	E.SAF can be reset by bit 7 of Control word 1 (STW1).	Communication

◆ Functions available for the inverters manufactured in July 2023 or later

- Firmware version: 12 or later

Item	Details	Related manuals
SF-PR motor capacity	200 V class: 0.2 kW and 0.4 kW are added. 400 V class: 0.2 kW and 0.4 kW are added.	Function
EM-A motor capacity	400 V class: 0.4 kW to 1.5 kW, and 7.5 kW are added.	Connection/ Function
Position control function	Added parameters • Pr.1095 to Pr.1097	Function
	Setting values • Setting values "21 and 22" added for Pr.538	
SLMP communication specifications	Added link registers • W5807 and W5808 (inverter status) • W5900 to W5969 (fault history)	Communication
Plug-in option	FR-E8AXY E kit	FR-E8AXY E Kit Instruction Manual
Control terminal option	FR-E8TR and FR-E8TE7	FR-E8TR Instruction Manual FR-E8TE7 Instruction Manual

◆ Functions available for the inverters manufactured in October 2023 or later

- Firmware version: 12 or later

Item	Details	Related manuals
IP67 model	400 V class: 0.75 kW to 3.7 kW	Connection/ Function/ Communication/ Maintenance
	Added parameter • Pr.508	
	BACnet/IP communication specifications • Binary input: object identifiers 100, 104, and 106 added. • Binary output: object identifiers 0, 4, and 6 added.	
	E.IAH (Abnormal internal temperature) fault added	
Parameters	Pr.197 added	Function

◆ Functions available for the inverters manufactured in September 2024 or later

- Firmware version: 13 or later

Item	Details	Related manuals
Selection between resetting or not resetting during power supply to main circuit	Setting values • Setting values "100 to 102" added for Pr.30	Function

- Firmware version: 14 or later

Item	Details	Related manuals
FSoE	The FR-E800-SCEPC models are added.	Function/ Communication/ Functional Safety
Parameter available for the Ethernet model, the safety communication model, and the IP67 model	Pr.56 can be read or written regardless of whether the plug-in option is installed.	Function
Parameter available for the FR-E800-EPC	Pr.1457 added (FR-E800-EPC inverters manufactured in August 2024 or earlier do not support this parameter even if the firmware is updated to version 14 or later.)	Function/ Communication

Warranty

When using this product, make sure to understand the warranty described below.

1. Warranty period and coverage

We will repair any failure or defect (hereinafter referred to as "failure") in our FA equipment (hereinafter referred to as the "Product") arisen during warranty period at no charge due to causes for which we are responsible through the distributor from which you purchased the Product or our service provider. However, we will charge the actual cost of dispatching our engineer for an on-site repair work on request by customer in Japan or overseas countries. We are not responsible for any on-site readjustment and/or trial run that may be required after a defective unit are repaired or replaced.

[Term]

The term of warranty for Product is twelve months after your purchase or delivery of the Product to a place designated by you or eighteen months from the date of manufacture whichever comes first ("Warranty Period"). Warranty period for repaired Product cannot exceed beyond the original warranty period before any repair work.

[Limitations]

- (1) You are requested to conduct an initial failure diagnosis by yourself, as a general rule. It can also be carried out by us or our service company upon your request and the actual cost will be charged.
However, it will not be charged if we are responsible for the cause of the failure.
- (2) This limited warranty applies only when the condition, method, environment, etc. of use are in compliance with the terms and conditions and instructions that are set forth in the instruction manual and user manual for the Product and the caution label affixed to the Product.
- (3) Even during the term of warranty, the repair cost will be charged on you in the following cases;
 - a failure caused by your improper storing or handling, carelessness or negligence, etc., and a failure caused by your hardware or software problem
 - a failure caused by any alteration, etc. to the Product made on your side without our approval
 - a failure which may be regarded as avoidable, if your equipment in which the Product is incorporated is equipped with a safety device required by applicable laws and has any function or structure considered to be indispensable according to a common sense in the industry
 - a failure which may be regarded as avoidable if consumable parts designated in the instruction manual, etc. are duly maintained and replaced
 - any replacement of consumable parts (condenser, cooling fan, etc.)
 - a failure caused by external factors such as inevitable accidents, including without limitation fire and abnormal fluctuation of voltage, and acts of God, including without limitation earthquake, lightning and natural disasters
 - a failure caused by using the emergency drive function
 - a failure generated by an unforeseeable cause with a scientific technology that was not available at the time of the shipment of the Product from our company
 - any other failures which we are not responsible for or which you acknowledge we are not responsible for

2. Term of warranty after the stop of production

- (1) We may accept the repair at charge for another seven (7) years after the production of the product is discontinued. The announcement of the stop of production for each model can be seen in our Sales and Service, etc.
- (2) Please note that the Product (including its spare parts) cannot be ordered after its stop of production.

3. Service in overseas

Our regional FA Center in overseas countries will accept the repair work of the Product; however, the terms and conditions of the repair work may differ depending on each FA Center. Please ask your local FA center for details.

4. Exclusion of loss in opportunity and secondary loss from warranty liability

Regardless of the gratis warranty term, Mitsubishi Electric shall not be liable for compensation to:

- (1) Damages caused by any cause found not to be the responsibility of Mitsubishi Electric.
- (2) Loss in opportunity, lost profits incurred to the user by Failures of Mitsubishi Electric products.
- (3) Special damages and secondary damages whether foreseeable or not, compensation for accidents, and compensation for damages to products other than Mitsubishi Electric products.
- (4) Replacement by the user, maintenance of on-site equipment, start-up test run and other tasks.

5. Change of Product specifications

Specifications listed in our catalogs, manuals or technical documents may be changed without notice.

6. Application and use of the Product

- (1) For the use of our product, its applications should be those that may not result in a serious damage even if any failure or malfunction occurs in product, and a backup or fail-safe function should operate on an external system to product when any failure or malfunction occurs.
- (2) Our product is designed and manufactured as a general purpose product for use at general industries.
Therefore, applications substantially influential on the public interest for such as atomic power plants and other power plants of electric power companies, and also which require a special quality assurance system, including applications for railway companies and government or public offices are not recommended, and we assume no responsibility for any failure caused by these applications when used.

In addition, applications which may be substantially influential to human lives or properties for such as airlines, medical treatments, railway service, incineration and fuel systems, man-operated material handling equipment, entertainment machines, safety machines, etc. are not recommended, and we assume no responsibility for any failure caused by these applications when used. We will review the acceptability of the abovementioned applications, if you agree not to require a specific quality for a specific application. Please contact us for consultation.

Revisions

*The manual number is given on the bottom left of the back cover.

Revision date	*Manual number	Revision
Dec. 2019	IB(NA)-0600871ENG-A	First edition
Apr. 2020	IB(NA)-0600871ENG-B	Added <ul style="list-style-type: none"> FR-E820S-0008(0.1K) to 0110(2.2K)(E/SCE) FR-E800-SCE (safety communication model)
Jun. 2020	IB(NA)-0600871ENG-C	Added <ul style="list-style-type: none"> How to check specification changes
Jun. 2020	IB(NA)-0600871ENG-D	Added <ul style="list-style-type: none"> Vector control Parameter unit (FR-PU07) EtherNet/IP: Inverter Configuration Object (64h) PROFINET: Inverter parameters, monitor data, and inverter control parameters
Nov. 2020	IB(NA)-0600871ENG-E	Added <ul style="list-style-type: none"> FR-E820-0470(11K) to 0900(22K)(E)(SCE), FR-E840-0230(11K) to 0440(22K)(E)(SCE) Position control (Vector control) User defined cyclic communication (Pr.1318, Pr.1319, Pr.1320 to Pr.1343) MODBUS/TCP: CiA402 drive profile (speed control) Backup/restore
Apr. 2021	IB(NA)-0600871ENG-F	Added <ul style="list-style-type: none"> FR-E800-EPC (EtherCAT) CC-Link IE TSN, MODBUS/TCP, EtherNet/IP, and PROFINET: CiA402 drive profile (torque control and position control) User defined cyclic communication (Pr.1389 to Pr.1398)
Jul. 2021	IB(NA)-0600871ENG-G	Added <ul style="list-style-type: none"> BACnet MS/TP
Mar. 2022	IB(NA)-0600871ENG-H	Added <ul style="list-style-type: none"> CC-Link IE TSN communication specifications (Pr.1210) EtherNet/IP instance 21216 (Speed scale (numerator)) and instance 21217 (Speed scale (denominator))
Aug. 2022	IB(NA)-0600871ENG-J	Added <ul style="list-style-type: none"> FR-E810W-0008(0.1K) to 0050(0.75K)(E)(SCE)
Sep. 2022	IB(NA)-0600871ENG-K	Added <ul style="list-style-type: none"> Network port for BACnet/IP and BACnet MS/TP
May 2023	IB(NA)-0600871ENG-L	Added <ul style="list-style-type: none"> PROFINET GSDML file Link registers for SLMP FR-E8AXY, FR-E8TR, and FR-E8TE7
Jul. 2023	IB(NA)-0600871ENG-M	Added <ul style="list-style-type: none"> Pr.197 FR-E806 (IP67 model)
Jul. 2024	IB(NA)-0600871ENG-N	Added <ul style="list-style-type: none"> FR-E800-SCEPC

Model	FR-E800 TORISETSU TSUSHIN EIBUN
Model code	1AJ051

MITSUBISHI ELECTRIC CORPORATION

HEAD OFFICE: TOKYO BUILDING 2-7-3, MARUNOUCHI, CHIYODA-KU, TOKYO 100-8310, JAPAN