

GRAPHIC OPERATION TERMINAL MELHMI
GOT3000

GOT3000 Series
User's Manual (Hardware)



-GT37 wide model
-GT37 model

Safety precautions

Always read the precautions before using this product.

Also read this manual and the relevant manuals mentioned in this manual carefully, and use the product properly while paying full attention to safety.

Note that the precautions in this manual apply only to this product.

The safety precautions are divided into the following levels:  WARNING and  CAUTION.



Indicates that incorrect handling may cause hazardous conditions, resulting in death or severe injury.



Indicates that incorrect handling may cause hazardous conditions, resulting in minor or moderate injury or property damage.

Note that failure to observe  CAUTION may lead to a serious accident depending on the circumstances.

Make sure to observe both warnings and cautions to ensure personal safety.

Ensure that this manual is easily accessible to all users of this product.

[Design precautions]

WARNING

- To maintain the security (availability, integrity, and confidentiality) of the GOT and the system against unauthorized access, DoS*¹ attacks, computer viruses, and other cyberattacks from unreliable networks and devices via network, take appropriate measures such as firewalls, virtual private networks (VPNs), and antivirus solutions.

Mitsubishi Electric shall have no responsibility or liability for any problems involving GOT trouble and system trouble by unauthorized access, DoS attacks, computer viruses, and other cyberattacks.

*1 DoS: A denial-of-service (DoS) attack disrupts services by overloading systems or exploiting vulnerabilities, resulting in a denial-of-service (DoS) state.

- Periodically check our vulnerability site, and if any vulnerabilities are found, upgrade the software and related components.
- Some failures of the GOT, communication unit or cable may keep the outputs on or off.
Some failures of the touch panel may cause a malfunction of input objects such as a touch switch.
Create an external monitoring circuit to check for output signals which may lead to a serious accident.
Not doing so may cause an accident due to false output or malfunction.
- Do not use the GOT as the warning device that warns you of serious accidents.
For the device that displays or outputs serious warnings, provide an independent redundant hardware or mechanical interlock.
Not doing so may cause an accident due to false output or malfunction.
- When the GOT backlight has a failure, the POWER LED blinks (lime green/unlit) and the display section dims. In such a case, the input by the touch switch(es) is disabled.
- When multiple points of the display section are touched simultaneously, an accident may occur due to false output or malfunction.

[GT37-W]

The display section of the GOT is capacitive.

Touching three points or more simultaneously on the display section may cause an accident due to false output or malfunction.

Do not do so.

[GT37-X]

The display section of the GOT is an analog-resistive type touch panel.

Touching two points or more simultaneously on the display section may cause an accident due to false output or malfunction.

If you do so, a touch switch near the touched points may operate.

Do not touch two points or more simultaneously on the display section.

- If you have changed a program or parameter of the controller (such as a PLC) that is monitored by the GOT, reset the GOT or turn off the GOT and immediately turn it on again.
Not doing so may cause an accident due to false output or malfunction.
 - If a communication fault (including cable disconnection) occurs during monitoring on the GOT, communication between the GOT and PLC CPU is suspended and the GOT becomes inoperative.
A system where the GOT is used should be configured to perform any significant operation to the system by using the switches of a device other than the GOT on the assumption that a GOT communication fault will occur.
Not doing so may cause an accident due to false output or malfunction.
-

[Design precautions]

CAUTION

- When the GOT connects to an Ethernet network, the IP address setting is restricted according to the system configuration.
When a GOT1000 series model is on an Ethernet network, do not set the IP address 192.168.0.18 for the GOT and the controller on this network.
Doing so may cause IP address duplication at the GOT startup, adversely affecting the communication of the device with the IP address 192.168.0.18.
The operation at IP address duplication depends on the devices and the system.
 - When using the Ethernet interfaces, set an IP address for each interface to access a different network.
 - When the GOT is exposed to a vibration or shock, or the GOT screen displays a specific image pattern, the screen may flicker or the colors may change.
 - Do not run control line cables and communication cables together with or near main circuit cables, power line cables, or other cables.
Run these cables separately from such wiring and keep them a minimum of 100 mm apart.
Not doing so may cause a malfunction due to noise.
-

[Installation precautions]

WARNING

- Before installing or removing the GOT on or from the control panel, shut off all phases of the external power supply used by the system.
Not doing so may result in an electric shock, product damage or malfunction.
 - Before installing/removing the communication unit or the option unit on/from the GOT, shut off all phases of the external power supply used by the system.
Not doing so may result in an electric shock, product damage or malfunction.
-

[Installation precautions]

CAUTION

- Use the GOT in the environment that satisfies the General specifications described in this manual.
Not doing so can cause an electric shock, fire, malfunction, or product damage or deterioration.
 - When installing the GOT on the control panel, use a Phillips-head screwdriver No. 2 to tighten mounting screws within the specified torque range as shown below.
 - Specified torque range (0.36 N·m to 0.48 N·m)Undertightening may cause the unit to fall off, short circuit, or malfunction.
Overtightening may cause the unit to fall off, short circuit, or malfunction due to damage to the screws or the unit.
 - To install a communication unit or an option unit on the GOT, the extension interface converter unit must be installed onto the extension interface of the GOT.
When installing the extension interface converter unit and a communication unit or an option unit, tighten the mounting screws within the specified torque range (0.36 N·m to 0.48 N·m) with a cross-head screwdriver No. 2.
 - When closing the USB environmental protection cover, fix the cover to the GOT by pushing the [Δ] mark on the latch firmly to comply with the protective structure.
 - Remove the protective film of the GOT.
Continued use of the GOT with the protective film attached may prevent the film from being removed.
In addition, for the models equipped with the human sensor function, using the GOT with the protective film may cause the human sensor not to function properly.
 - Do not use or store the product in an environment subject to direct sunlight, rain, high temperatures, dust, high humidity, or frequent vibration.
 - Do not operate the product with its display section frozen.
The water droplets on the display section may freeze at a low temperature.
Touch switches and other input objects may malfunction if the display section is frozen.
-

[Wiring precautions]

WARNING

- Before wiring, make sure to shut off all phases of the external power supply used by the system. Not doing so may result in an electric shock, product damage or malfunction.
-

[Wiring precautions]

CAUTION

- Make sure to ground the FG terminal and LG terminal of the GOT power supply section using a grounding wire dedicated to the GOT. (Ground resistance: 100 Ω or less, ground cable diameter: 1.6 mm or more)
Not doing so may result in an electric shock or malfunction.
 - When wiring the GOT power section, tighten the terminal screws using a Phillips-head screwdriver No. 2 within the specified torque range below.
 - Specified torque range: (0.5 N·m to 0.8 N·m)
 - Use an applicable solderless terminal for terminal processing of a wire to the GOT power supply section and tighten them with the specified torque.
Using a solderless spade terminal can cause it to fall off and lead to a malfunction if the terminal screws become loose.
 - Correctly wire the GOT power supply section after confirming the rated voltage and terminal layout of the product.
Not doing so can cause a fire or malfunction.
 - Plug the communication cable into the GOT interface or the connector of the connected unit, and tighten the mounting screws and the terminal screws within the specified torque range (0.5 N·m to 0.8 N·m).
Undertightening may cause a short circuit or malfunction.
Overtightening may cause a short circuit or malfunction due to damage to the screws or unit.
 - Exercise care to avoid foreign matter such as chips and wire offcuts entering the unit.
Not doing so can cause a fire, failure or malfunction.
-

[Input operation precautions]

WARNING

- Thoroughly read the manual to fully understand the operating procedures before performing input operations on a user-created screen (such as turning a bit device on or off, changing the current value of a word device, changing the set or current value of a timer or counter, or changing the current value of a buffer memory or parameter).
During the input operation, never change the data of the devices which are used to perform significant operation for the system.
Doing so may cause an accident due to an incorrect output or malfunction.
-

[Startup/maintenance precautions]

WARNING

- Do not touch the terminals while power is on.
Close the terminal block cover before supplying power.
Not doing so may cause an electric shock or malfunction.
 - Correctly connect the battery connector.
Do not perform the following actions on the battery:
 - Charging, disassembling, heating, throwing into fire, short-circuiting, soldering, etc.Improper handling of the battery may cause heat generation, explosion, or ignition, resulting in injury or fire hazards.
 - Before cleaning or terminal screw retightening, make sure to shut off all phrases of the external power supply.
Not doing so may cause the unit to fail or malfunction.
Undertightening may cause a short circuit or malfunction.
Overtightening may cause a short circuit or malfunction due to damage to the screws or unit.
-

[Startup/maintenance precautions]

CAUTION

- Do not disassemble or modify the unit.
Doing so can cause a failure, malfunction, injury or fire.
 - Do not touch the conductive and electronic parts of the unit directly.
Doing so may cause a unit malfunction or failure.
 - The cables connected to the unit must be run in ducts or clamped.
Not doing so can cause the unit or cable to be damaged due to the dangling, motion or accidental pulling of the cables, or can cause a malfunction due to a cable connection fault.
 - When unplugging the cable connected to the unit, do not hold and pull from the cable portion.
Doing so can cause the unit or cable to be damaged or can cause a malfunction due to a cable connection fault.
 - Do not drop the unit or subject it to strong shock.
A unit damage may result.
 - Do not drop or give an impact to the battery mounted to the unit.
Doing so may damage the battery, causing the battery fluid to leak inside the battery. If the battery is dropped or given an impact, dispose of it without using it.
 - Before touching the unit, always touch grounded metals, etc. to discharge static electricity from human body, etc.
Not doing so may cause the unit to fail or malfunction.
 - Use the battery manufactured by Mitsubishi Electric Corporation.
Use of other batteries may cause a risk of fire or explosion.
 - Dispose of the used battery promptly.
Keep it away from children.
Do not disassemble and dispose of it in fire.
 - Before replacing the battery or setting the terminating resistor using a selector switch, make sure to shut off all phases of the external power supply.
Not doing so can cause the unit to fail or malfunction due to static electricity.
 - When setting the terminating resistor using the selector switch, do not use a pointed metal object.
 - When the extension unit is not used, do not leave it uncovered.
Otherwise, the unit may fail or malfunction due to static electricity.
 - Turn off the power when cleaning the GOT.
Also, before cleaning, ensure that the GOT is properly installed on the control panel.
-

[Touch panel precautions]

WARNING

- For the analog-resistive film type touch panels, normally the adjustment is not required. However, the difference between a touched position and the object position may occur as the period of use elapses. When any difference between a touched position and the object position occurs, execute the touch panel calibration.
When any difference between a touched position and the object position occurs, other object may be activated. This may cause an unexpected operation due to incorrect output or malfunction.
 - For the capacitive touch panel, pay attention to the following points.
 - If the FG terminal of the GOT is not grounded, operability deterioration or malfunction may result.
 - If water, oil, or any other conductive material adheres to the GOT display, the GOT may malfunction. In such a case, wipe it off before use.
-

[Precautions for use of the data storage]

WARNING

- If the SD card in drive A of the GOT is removed while the GOT is accessing it, the GOT may stop processing for about 20 seconds.
During this stop, you cannot operate the GOT, and the functions running in the background, including the screen refresh, alarm, logging, and script, also stop.
This stop may affect the system operation, causing an accident.
Before removing the SD card, check that the SD card access LED is off.
-

[Precautions for use of the data storage]

CAUTION

- If you remove the data storage from the GOT while the GOT is accessing it, the data storage or files may get damaged.
Before removing the data storage, check the SD card access LED, relevant system signal, or others to make sure that the data storage is not being accessed.
If the data storage is damaged, the GOT may not function properly.
 - Turning off the GOT while it accesses the SD card results in damage to the SD card and files.
 - After inserting an SD card into the GOT, make sure to close the SD card cover.
Not doing so may prevent the data from being read or written.
 - To remove the data storage from the GOT, follow the procedure for removal on the utility screen of the GOT. After the successful completion dialog appears, remove the data storage while holding it carefully.
Not doing so may cause the data storage to drop, resulting in damage or failure.
-

[Precautions for use]

CAUTION

- Do not press the GOT display section with a pointed object such as a pen or screwdriver.
Doing so may result in damage or failure.
 - When inserting a USB device into a USB interface of the GOT, make sure to insert the device into the interface firmly.
Not doing so may cause a malfunction due to poor contact.
 - The digital video output interface of the GOT is intended solely for output.
Do not connect this interface to the output terminal of another device.
Doing so may result in failure.
 - Do not touch the edges of the analog resistive touch panel (display section) repeatedly.
Doing so may result in failure.
 - When the extension unit is not used, do not leave it uncovered.
Otherwise, the unit may fail or malfunction due to static electricity.
 - Do not turn off the GOT while data is being written to the storage memory (ROM) or SD card.
Doing so may corrupt the data, rendering the GOT inoperative.
-

[Remote control precautions]

WARNING

- Remote control is available through a network by using GOT functions, including the VNC server function and the GOT Mobile function.
If these functions are used to perform remote control of control equipment, the field operator may not notice the remote control, possibly leading to an accident.
In addition, a communication delay or interruption may occur depending on the network environment, and remote control of control equipment cannot be performed normally in some cases.
Before using the above functions to perform remote control, fully grasp the circumstances of the field site and ensure safety.
 - When operating the server (GOT) of the GOT Mobile function to disconnect a client, notify the operator of the client about the disconnection beforehand.
Not doing so may cause an accident.
-

[Disposal precautions]

CAUTION

- Dispose of this product as industrial waste.
When disposing of batteries, separate them from other wastes according to the local regulations. (For details on the battery regulations in the EU member states, refer to "Low-voltage battery detection and replacement".)
-

[Transportation precautions]

CAUTION

- When transporting lithium batteries, make sure to treat them based on the transport regulations. (For details on the regulated models, refer to the Transportation precautions.)
 - Make sure to transport the GOT main unit and/or relevant unit(s) in the manner they will not be exposed to the impact exceeding the impact resistance described in the General specifications of this manual, as they are precision devices.
Not doing so may cause the unit to fail.
Check if the unit operates correctly after transportation.
 - Prevent the entry of halogens (including fluorine, chlorine, bromine, and iodine) contained in fumigants used for fumigating wood packaging materials, or a product failure may occur.
Make sure that fumigant residues will not enter the product, or use an alternative (heat treatment or others) to fumigation.
Before packing the product, disinfect wood packaging materials and eliminate insects from the materials.
-

Product application

- (1) Mitsubishi graphic operation terminal ("the PRODUCT") shall be used in conditions;
 - i) where any problem, fault or failure occurring in the PRODUCT, if any, shall not lead to any major or serious accident; and
 - ii) where the backup and fail-safe function are systematically or automatically provided outside of the PRODUCT for the case of any problem, fault or failure occurring in the PRODUCT.
- (2) The PRODUCT has been designed and manufactured for the purpose of being used in general industries. MITSUBISHI ELECTRIC SHALL HAVE NO RESPONSIBILITY OR LIABILITY (INCLUDING, BUT NOT LIMITED TO ANY AND ALL RESPONSIBILITY OR LIABILITY BASED ON CONTRACT, WARRANTY, TORT, PRODUCT LIABILITY) FOR ANY INJURY OR DEATH TO PERSONS OR LOSS OR DAMAGE TO PROPERTY CAUSED BY the PRODUCT THAT ARE OPERATED OR USED IN APPLICATION NOT INTENDED OR EXCLUDED BY INSTRUCTIONS, PRECAUTIONS, OR WARNING CONTAINED IN MITSUBISHI ELECTRIC USER'S, INSTRUCTION AND/OR SAFETY MANUALS, TECHNICAL BULLETINS AND GUIDELINES FOR the PRODUCT. ("Prohibited Application")
 - Nuclear Power Plants and any other power plants operated by Power companies, and/or any other cases in which the public could be affected if any problem or fault occurs in the PRODUCT.
 - Railway companies or Public service purposes, and/or any other cases in which establishment of a special quality assurance system is required by the Purchaser or End User.
 - Aircraft or Aerospace, Medical applications, Train equipment, transport equipment such as Elevator and Escalator, Incineration and Fuel devices, Vehicles, Manned transportation, Equipment for Recreation and Amusement, and Safety devices, handling of Nuclear or Hazardous Materials or Chemicals, Mining and Drilling, and/or other applications where there is a significant risk of injury to the public or property.Notwithstanding the above restrictions, Mitsubishi Electric may in its sole discretion, authorize use of the PRODUCT in one or more of the Prohibited Applications, provided that the usage of the PRODUCT is limited only for the specific applications agreed to by Mitsubishi Electric and provided further that no special quality assurance or fail-safe, redundant or other safety features which exceed the general specifications of the PRODUCTS are required. For details, please contact the Mitsubishi Electric representative in your region.
- (3) Mitsubishi Electric shall have no responsibility or liability for any problems involving graphic operation terminal trouble and system trouble caused by DoS attacks, unauthorized access, computer viruses, and other cyberattacks.

Introduction

Thank you for choosing Mitsubishi Electric Graphic Operation Terminal (GOT).

Before using the product, read this manual carefully and make sure you understand the functions and performance of the GOT for correct use.

CONTENTS

Safety precautions	1
Product application	12
Introduction	13
Relevant manuals	18
Abbreviations, generic terms, and model icons	19

PART 1 How to read this manual

CHAPTER 1 Useful information 23

1.1 Finding the reference manual	23
----------------------------------------	----

PART 2 System configuration

CHAPTER 2 Overall configuration 28

CHAPTER 3 How to read the GOT model name 29

CHAPTER 4 System equipment 30

4.1 GOT	30
4.2 Extension unit	31
4.3 Software	32
4.4 Licenses	33
4.5 Option	35
4.6 Cable	36
4.7 Peripherals	38

PART 3 Specifications

CHAPTER 5 GOT3000 series common specifications 41

5.1 General specifications	41
----------------------------------	----

CHAPTER 6 GT37 42

6.1 GT3715-FH, GT3712-WX	42
6.2 GT3715-X, GT3712-X, GT3710-X, GT3708-X	47

CHAPTER 7 Battery 55

CHAPTER 8 Communication cable 56

8.1 Panel-mounted USB port extension	56
--------------------------------------------	----

PART 4 Part names and settings

CHAPTER 9 GT37 58

9.1 GT3715-FH, GT3712-WX	58
--------------------------------	----

9.2	GT3715-X, GT3712-X, GT3710-X, GT3708-X	60
-----	----------------------------------------------	----

PART 5 Operating the GOT

CHAPTER 10	Procedure before operation	63
10.1	Procedure before operating the GOT	64

PART 6 Installation and removal

CHAPTER 11	Precautions for installing the GOT	66
-------------------	-------------------------------------------	-----------

CHAPTER 12	Installation position	67
12.1	GT37	67

CHAPTER 13	Control panel inside temperature and GOT installation angle	71
13.1	GT37	71

CHAPTER 14	Installing and removing the GOT	72
14.1	Installing the GOT	72
14.2	Removing the GOT	74

CHAPTER 15	Installing and removing the extension unit	75
15.1	Installation	75
15.2	Removal	80

CHAPTER 16	Installing and removing the battery	82
16.1	Installing the battery	82
16.2	Removing the battery	84

CHAPTER 17	Inserting and removing the SD card	85
17.1	Inserting the SD card	86
17.2	Removing the SD Card	87

CHAPTER 18	Inserting and removing a USB device	88
18.1	Inserting a USB device	88
18.2	Removing the USB device	90

CHAPTER 19	Inserting and removing the USB cable	91
19.1	Inserting the USB cable	91
19.2	Removing the USB cable	93

CHAPTER 20	Installing and removing the panel-mounted USB port extension	95
20.1	Part names of the panel-mounted USB port extension	95
20.2	Installing and removing the panel-mounted USB port extension	96

CHAPTER 21	Inserting and removing the HDMI cable	97
21.1	Installing the HDMI cable	97
21.2	Removing the HDMI cable	99

PART 7 Wiring of power supply section

CHAPTER 22 Precautions for wiring the power supply	102
CHAPTER 23 Wiring of external power supply	103
23.1 Separating the power supply system	103
23.2 Separating the power cables from the main circuit cables and the I/O signal cables	103
23.3 Treatment of the power cables	103
23.4 Connecting the lightning surge absorber	103
CHAPTER 24 Power supply wiring to the GOT	104
CHAPTER 25 Grounding	105
25.1 Grounding the GOT	105
25.2 Causes of wiring-related malfunction and countermeasure examples	108
CHAPTER 26 Wiring inside and outside the control panel	110
26.1 Control panel inside wiring	110
26.2 Control panel outside wiring	111
CHAPTER 27 Attaching a surge suppressor to control equipment	112

PART 8 Maintenance and inspection

CHAPTER 28 Inspection	114
28.1 Daily inspection	116
28.2 Periodic Inspection	117
CHAPTER 29 Screen cleaning method	118
CHAPTER 30 Low-voltage battery detection and replacement	119
30.1 Low-voltage battery detection and replacement	119
30.2 Handling of batteries and devices with built-in batteries in EU member states	120

PART 9 Troubleshooting

CHAPTER 31 GOT restoration sheets	122
31.1 GOT status check sheet	123
31.2 GOT installation status check sheet	130
31.3 System configuration check sheet	137
CHAPTER 32 Error messages and system alarms	138
32.1 Displayed contents	138
32.2 Error messages and system alarms	141

PART 10 EMC Directive and Low Voltage Directive

CHAPTER 33 Overview	143
33.1 Conforming standards in the EMC Directive	144
33.2 Conforming standards in the Low Voltage Directive	145
CHAPTER 34 EMC Directive Requirements	146
34.1 Installing the GOT on the control panel	147
34.2 Installing a noise filter (power supply line filter)	148
34.3 System configuration	149
34.4 Connection of power cables and ground cables	153
34.5 Fabricating a connection cable	154
34.6 Grounding a cable	159
CHAPTER 35 Low Voltage Directive requirements	160
35.1 Power supply	160
35.2 Control panel	161
35.3 Grounding	162
35.4 External wiring	163
Appendices	164
Appendix 1 Cable bend radius for GT37 with an extension unit	164
Appendix 2 Confirmation of versions and conforming standards	171
Appendix 3 Transportation precautions	172
Appendix 4 Open source software	173
Appendix 5 Précautions d'installation du GOT	182
Appendix 6 Position d'installation	183
Appendix 7 Température intérieure du tableau de commande et angle d'installation de GOT	187
Revisions	188
Warranty	189
Trademarks	190
Copyrights	190

Relevant manuals



e-Manual refers to the Mitsubishi Electric FA electronic book manuals that can be browsed using a dedicated tool.

e-Manual has the following features:

- Required information can be cross-searched in multiple manuals.
- Other manuals can be accessed from the links in the manual.
- Hardware specifications of each part can be found from the product figures.
- Pages that users often browse can be bookmarked.
- Sample programs can be copied to the engineering tool.

Screen design software-related manuals

Manual name	Manual number	Format
GT Works3 Installation Instructions	—	PDF e-Manual
GT Designer3 (GOT3000) Screen Design Manual	SH-082590ENG	PDF e-Manual

Connection manuals

Manual name	Manual number	Format
GOT3000 Series User's Manual (Connection)	SH-082593ENG	PDF e-Manual

GT SoftGOT3000 manual

Manual name	Manual number	Format
GT SoftGOT3000 User's Manual	SH-082594ENG	PDF e-Manual





GOT3000 series user manuals

Manual name	Manual number	Format
GOT3000 Series User's Manual (Hardware)	SH-082591ENG	PDF e-Manual Bound document
GOT3000 Series User's Manual (Utility & Maintenance Functions)	SH-082592ENG	PDF e-Manual

Abbreviations, generic terms, and model icons

The following shows the abbreviations, generic terms, and model icons used in this manual.

GOT3000 series

Abbreviations and generic terms		Description	Meaning of icon		
			Available	Unavailable	
GT37	GT37-W	GT3715-FHCBD			
		GT3712-WXCBD			
	GT37-X	GT3715-X			GT3715-XRBA GT3715-XRBD
		GT3712-X			GT3712-XRBA GT3712-XRBD
		GT3710-X			GT3710-XRBA GT3710-XRBD
GT3708-X	GT3708-XRBA GT3708-XRBD				
GT SoftGOT3000		GT SoftGOT3000 Version1			

GOT2000 series and GOT1000 series

Abbreviations and generic terms		Description	Meaning of icon	
			Available	Unavailable
GOT2000 series		GOT2000 series	—	—
GOT1000 series		GOT1000 series	—	—

GOT units and option units

Abbreviations and generic terms		Description
Extension interface converter unit		This unit connects the extension unit of the GOT2000 series and GOT1000 series to the GOT3000 series.
Extension unit	Communication unit	A unit, such as the serial communication unit or CC-Link IE TSN communication unit, installed on the GOT to enable communication with other devices
	Option unit	A unit, such as an external I/O unit, installed on the GOT to provide specific functions
Option		Options, such as SD cards, batteries, and protective sheets, installed on the GOT for use

Software

■Software related to GOT

Abbreviations and generic terms	Description
GT Works3	Software that comprehensively supports screen design for the GOT
GT Works3 Version1	
GT Designer3	Screen design software for the GOT3000 series, GOT2000 series, and GOT1000 series
GT Designer3 (GOT3000)	Screen design software for the GOT3000 series
Speech synthesis license	License to use the speech synthesis function
VNC server function license	License to use the VNC server function with the GOT3000
VPN function license	License to use the VPN function with the GOT3000
License for the remote personal computer operation function (Ethernet)	License to use the remote personal computer operation function (Ethernet) in the GOT3000
Multimedia function license	License to perform the following with the GOT3000 <ul style="list-style-type: none"> • Use a network camera. • Record or play images taken by a network camera or web camera.
License for GT SoftGOT3000	License to use GT SoftGOT3000
GOT Mobile function license for GOT3000	License to use the GOT Mobile function with the GOT3000
GOT Mobile function license for GT SoftGOT3000	License to use the GOT Mobile function with GT SoftGOT3000
GENESIS64 Advanced	GENESIS64 server application (GEN64-APP)
GENESIS64 Basic SCADA	GENESIS64 server application (GEN64-BASIC)
GENESIS64	Generic term of GENESIS64 Advanced and GENESIS64 Basic SCADA
GT Simulator3	Screen simulator GT Simulator3 for the GOT3000 series
GT SoftGOT3000	Software that performs the same functions as the GOT3000 on a personal computer or panel computer
GT OPC UA Client	OPC UA server connection setting software

■Software related to iQ Works

Abbreviations and generic terms	Description
iQ Works	iQ Platform compatible engineering environment MELSOFT iQ Works
MELSOFT Navigator	Integrated development environment software included in the iQ Platform-compatible engineering environment, MELSOFT iQ Works
MELSOFT iQ AppPortal	Integrated application management software

■Other software

Abbreviations and generic terms	Description	
GX Works3	Programmable controller engineering software	
GX Works2		
Controller simulator	GX Simulator3	Simulation function of GX Works3
	GX Simulator2	Simulation function of GX Works2
	GX Simulator	Ladder logic test tool function software package
GX Developer	Programmable controller programming software	
GX LogViewer	Dedicated logging data viewer	
MI Configurator	Configuration and monitor tool for Mitsubishi Electric industrial computers	
PX Developer	FBD software package for process control	
MT Works2	Motion controller engineering software	
MT Developer	Integrated start-up support software for motion controller Q series	
CW Configurator	Setting/monitoring tools for the C Controller module and MELSECWinCPU	
MR Configurator2	Servo configuration software	
MR Configurator	Servo configuration software	
FR Configurator2	Inverter setup software	
FR Configurator	Inverter setup software	
NC Configurator2	CNC parameter setting support software	
NC Configurator	CNC parameter setting support tool	
FX Configurator-FP	Parameter setting, monitoring, and testing software	
FX Configurator-EN-L	FX3U-ENET-L type Ethernet module setting software	
RT ToolBox3	Robot program creation software	
RT ToolBox2	Robot program creation software	
MX Component	Communication library	
MX Sheet	Communication support software package	
CPU Module Logging Configuration Tool	CPU Module Logging Configuration Tool	

PART 1

How to read this manual

1 Useful information

1

Useful information

☞ Page 23 Finding the reference manual

1.1 Finding the reference manual

This section describes the main GOT manuals and their contents.

The following abbreviations are used for the manual names.

Manual name	Abbreviation	Main contents
GT Designer3 (GOT3000) Screen Design Manual	GTD	<ul style="list-style-type: none">• Screen operation with GT Designer3• Settings of the functions that run on the GOT• Functions enabled by connecting the GOT and controllers
GOT3000 Series User's Manual (Hardware)	HW	<ul style="list-style-type: none">• GOT hardware specifications• How to connect cables to and install units on the GOT
GOT3000 Series User's Manual (Utility & Maintenance Functions)	UT	<ul style="list-style-type: none">• How to operate the utility• How to use dedicated screens such as a sequence program monitor• System alarms and corrective actions
GOT3000 Series User's Manual (Connection)	Connection	<ul style="list-style-type: none">• Devices connectable with the GOT• System configuration• Communication settings• FA transparent function (reading and writing programs between a personal computer and a controller via the GOT)
GT SoftGOT3000 User's Manual	SGT	<ul style="list-style-type: none">• How to operate GT SoftGOT3000

The following contents and their reference manuals are shown below.

- ☞ Page 24 Operations related to package data, BootOS, and CoreOS (data transfer)
- ☞ Page 24 How to protect the GOT and data
- ☞ Page 24 Operating the GOT using gestures
- ☞ Page 24 How to use GOT peripherals
- ☞ Page 25 Settings that can be changed in the utility or in GT Designer3
- ☞ Page 26 Devices, labels, and tags that can be monitored with the GOT
- ☞ Page 26 Drive configuration and capacity of the GOT
- ☞ Page 26 Differences between GT SoftGOT3000 functions and other functions

1.1.1 Operations related to package data, BootOS, and CoreOS (data transfer)

○: Available

—: Not available

Information on...	Reference				
	GTD	HW	UT	Connection	SGT
Reading/writing the package data	○	—	—	—	—
Writing the BootOS and the CoreOS (version upgrade)	○	—	—	—	—
How to use the package data of the GOT with another GOT (uploading and downloading)	—	—	○	—	—

1.1.2 How to protect the GOT and data

○: Available

—: Not available

Information on...	Reference				
	GTD	HW	UT	Connection	SGT
Security functions of the GOT and GT Designer3	○	—	—	—	○

1.1.3 Operating the GOT using gestures

○: Available

—: Not available

Information on...	Reference				
	GTD	HW	UT	Connection	SGT
Operating the GOT screen using gestures	○	—	—	—	—
Operating objects using gestures	○	—	—	—	—

1.1.4 How to use GOT peripherals

○: Available

—: Not available

Information on...	Reference				
	GTD	HW	UT	Connection	SGT
How to use a barcode reader	○	—	—	○	—
How to use an RFID controller	○	—	—	○	—
How to operate the personal computer from the GOT	○	—	—	○	—
How to use a VNC server	○	—	—	○	—
How to display or record images from a camera, video device, or other equipment on the GOT	○	—	—	○	—
How to display the GOT screen on an external display	○	—	—	○	—
How to play a sound file through speakers	○	—	—	○	—
How to use an external I/O device or an operation panel	○	—	—	○	—
How to monitor a controller on a tablet via the GOT	○	—	—	○	—
How to use the GOT as an OPC UA server	○	—	—	—	—
How to monitor a controller via the GOT	○	—	—	—	—
How to access GOT files from a peripheral	○	—	—	—	—
How to access files on an external server from the GOT	○	—	—	—	—

1.1.5 Settings that can be changed in the utility or in GT Designer3

The following shows whether utility menus can be set in GT Designer3.

When the package data is written to the GOT, the utility settings of the GOT can be updated to those of GT Designer3.

○: Available

—: Not available

Information on...		Reference				
		GTD	HW	UT	Connection	SGT
[GOT basic set] tab	[Display]	○	—	○	—	—
	[Language]	○	—	○	—	—
	[Unique info]	○	—	○	—	—
	[IP address]	○	—	○	—	—
	[IP filter setting]	○	—	○	—	—
	[Operation]	○	—	○	—	—
	[Utility call key]	○	—	○	—	—
	[USB device/host]	○	—	○	—	—
	[Time]	○	—	○	—	—
	[Controller]	○	—	○	—	—
	[Ethernet]	○	—	○	—	—
	[Transparent mode]	○	—	○	—	—
	[GOT internal device monitor]	○	—	○	—	—
	[Security] ^{*1}	○	—	○	—	—
	[Operator authentication management]	—	—	○	—	—
	[Opr authn. Password change]	—	—	○	—	—
	[Brightness adjustment]	○	—	○	—	—
[Add-on setting] tab	[SoftGOT-GOT link function]	○	—	○	—	—
	[VNC server function]	○	—	○	—	—
	[Seq. program monitor]	○	—	○	—	—
	[Backup restoration]	○	—	○	—	—
	[License management]	—	—	○	—	—
	[System launcher]	○	—	○	—	—
	[iQSS utility]	○	—	○	—	—
	[File transfer]	○	—	○	—	—
	[Mail]	○	—	○	—	—
	[Web browser function]	○	—	○	—	—
	[ANDON connection]	—	—	○	—	—
	[VPN connection function]	○	—	○	—	—
[Contactless tag function]	○	—	○	—	—	
[Maintenance]	—	—	○	—	—	
[Monitor]	—	—	○	—	—	
[Data mng.]	—	—	○	—	—	

*1 Appears only when the security mode is set to mode 1.

1.1.6 Devices, labels, and tags that can be monitored with the GOT

○: Available

—: Not available

Information on...	Reference				
	GTD	HW	UT	Connection	SGT
GOT internal device list	○	—	—	—	—
Mitsubishi Electric products device list	○	—	—	○	—
Non-Mitsubishi Electric products device list	○	—	—	○	—
Types of devices that can be monitored with the GOT	○	—	—	—	—
Types of labels and tags that can be monitored with the GOT	○	—	—	—	—

1.1.7 Drive configuration and capacity of the GOT

○: Available

—: Not available

Information on...	Reference				
	GTD	HW	UT	Connection	SGT
Drive configuration and capacity of the GOT	○	—	—	—	—
Virtual drive of GT SoftGOT3000	○	—	—	—	○

1.1.8 Differences between GT SoftGOT3000 functions and other functions

○: Available

—: Not available

Information on...	Reference				
	GTD	HW	UT	Connection	SGT
List of differences between GT SoftGOT3000 functions and other functions	—	—	—	—	○

PART 2

System configuration

2 Overall configuration

3 How to read the GOT model name

4 System equipment

2 Overall configuration

The following shows the overall configuration of the GOT3000 series.

For the system equipment such as the GOT and extension units, refer to the following.

☞ Page 30 System equipment

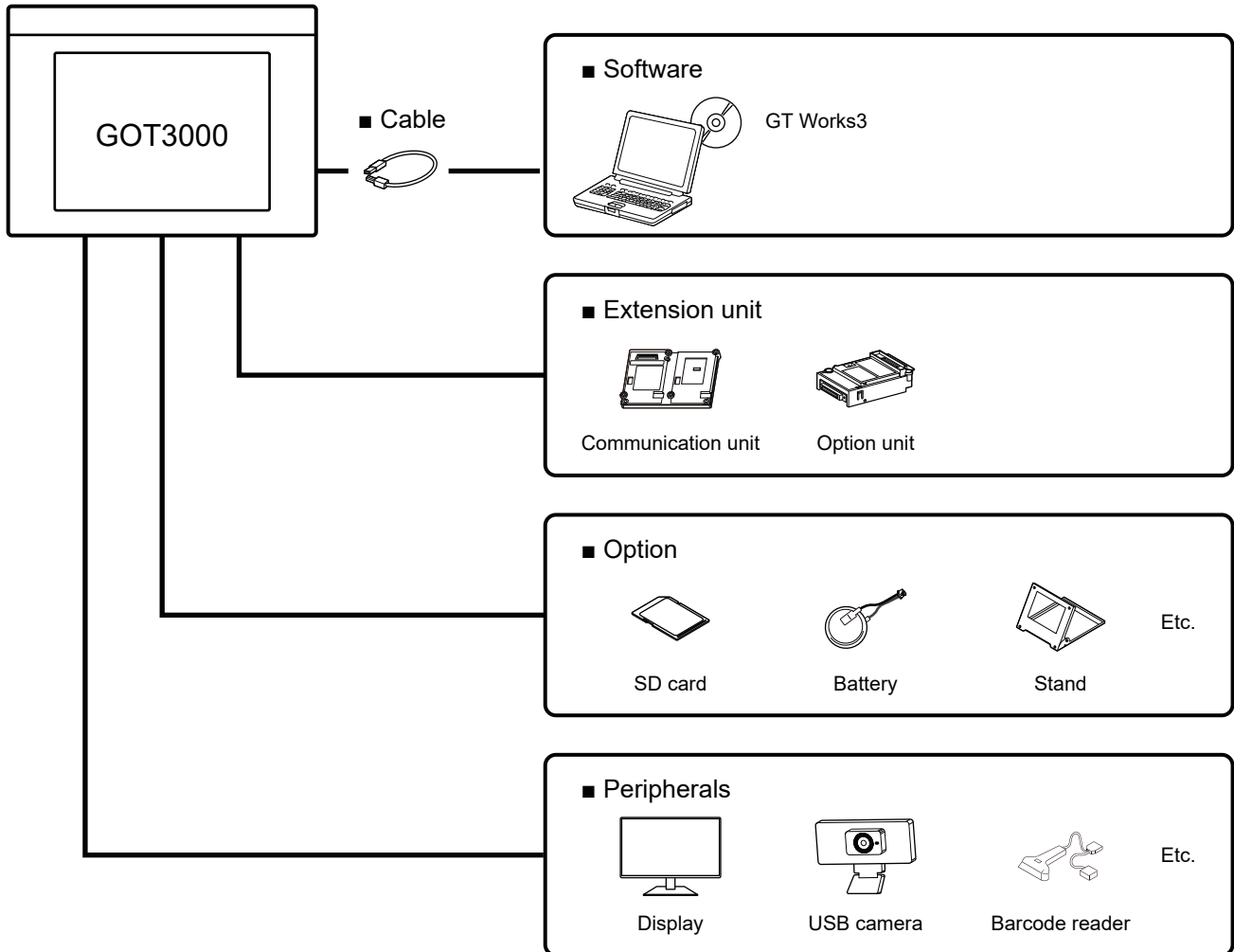

3

How to read the GOT model name

The following shows how to read the GOT model name.

GT37 15 - FH C B D

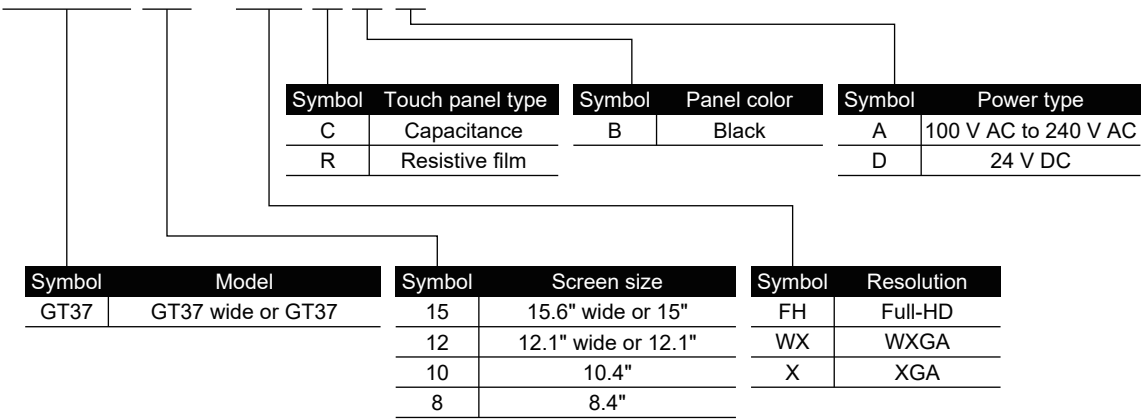

4 System equipment

The following shows the system equipment of the GOT3000 series.

- ☞ Page 30 GOT
- ☞ Page 31 Extension unit
- ☞ Page 32 Software
- ☞ Page 33 Licenses
- ☞ Page 35 Option
- ☞ Page 36 Cable
- ☞ Page 38 Peripherals

4.1 GOT

4.1.1 GT37

Category	Model	Screen size	Resolution	Display color	Panel color	Power supply	Remarks	
GT37 wide	GT3715	GT3715-FHCBD	15.6" wide	Full-HD	16 million colors	Black	DC	—
	GT3712	GT3712-WXCBD	12.1" wide	WXGA		Black	DC	
GT37	GT3715	GT3715-XRBA	15"	XGA	16 million colors	Black	AC	—
		GT3715-XRBD				Black	DC	
	GT3712	GT3712-XRBA	12.1"	XGA		Black	AC	
		GT3712-XRBD				Black	DC	
	GT3710	GT3710-XRBA	10.4"	XGA		Black	AC	
		GT3710-XRBD				Black	DC	
	GT3708	GT3708-XRBA	8.4"	XGA		Black	AC	
		GT3708-XRBD				Black	DC	

4.2 Extension unit

4.2.1 Extension units for the GOT2000 series and the GOT1000 series

When using communication units and option units for the GOT2000 series and GOT1000 series

When using communication units and option units for the GOT2000 series and GOT1000 series, install the extension interface conversion unit on the GOT.

On the extension interface conversion unit, only one communication unit or option unit can be installed.

For the method of installation or removal, refer to the following.

☞ Page 75 Installing and removing the extension unit

○: Usable, —: Not usable

Product	Model	Specifications	Model
			GT37
Extension interface converter unit	GT37-IF2000	Conversion unit for communication units and option units for the GOT2000 and GOT1000 series For mountable communication units and option units, refer to the following. ☞ Page 31 Communication units for the GOT2000 series and GOT1000 series	○

Communication units for the GOT2000 series and GOT1000 series

○: Usable, —: Not usable

Product	Model	Specifications	Model
			GT37
Serial communication unit	GT15-RS2-9P	RS-232 serial communication unit (D-sub 9-pin plug)	○
	GT15-RS4-9S	RS-422/485 serial communication unit (D-sub 9-pin socket)	
	GT15-RS4-TE	RS-422/485 serial communication unit (Terminal block)	
CC-Link IE TSN communication unit	GT25-J71GN13-T2	Local station (device station) unit	○
CC-Link IE Controller Network communication unit	GT15-J71GP23-SX	Normal station unit (optical loop)	○
CC-Link IE Field Network communication unit	GT15-J71GF13-T2	Intelligent device station unit	○
CC-Link communication unit	GT15-J61BT13	Intelligent device station unit CC-Link Ver. 2 compliant	○
Bus connection unit	GT15-QBUS	Q bus connection (1 channel) unit standard model	○
	GT15-QBUS2	Q bus connection (2 channels) unit standard model	
	GT15-75QBUSL	Q bus connection (1 channel) unit slim model	
	GT15-75QBUS2L	Q bus connection (2 channels) unit slim model	
MELSECNET/H communication unit	GT15-J71LP23-25	Normal station unit (optical loop)	○
	GT15-J71BR13	Normal station unit (coaxial bus)	

Option units for the GOT2000 series and GOT1000 series

○: Usable, —: Not usable

Product	Model	Specifications	Model
			GT37
External I/O unit	GT15-DIO	For connecting an external I/O device and an operation panel (Positive common input, sink type output)	○
	GT15-DIOR	For connecting an external I/O device and an operation panel (Negative common input, source type output)	

4.3 Software

Page 32 GT Works

4.3.1 GT Works

Product	Model	Language version	Description	
HMI/GOT Screen Design Software MELSOFT GT Works3	SW1DND-GTWK3-EC	English	Site license product.	DVD
	SW1DND-GTWK3-ECE	English	Available for use only by individuals from the same corporation that purchased the product, its business offices (including overseas offices), public vocational training facilities, or other educational institutions, with no limitations on the number of computers or users.	Digital distribution
	SW1DND-GTWK3-C	Chinese (Simplified)	Standard license product.	DVD

4.4 Licenses

☞ Page 33 GT SoftGOT3000

☞ Page 33 Add-on function

4.4.1 GT SoftGOT3000

License for GT SoftGOT3000

One license is required for each OS on the personal computer running this product.

Model	No. of sales licenses	Delivery type
GT3S-SGTKEYA1N-1	1	Digital distribution
GT3S-SGTKEYA1-1	1	License certificate
GT3S-SGTKEYA1-10	10	License certificate
GT3S-SGTKEYA1-20	20	License certificate

4.4.2 Add-on function

☞ Page 33 GOT Mobile function license for GOT3000

☞ Page 33 GOT Mobile function license for GT SoftGOT3000

☞ Page 33 License for the remote personal computer operation function (Ethernet)

☞ Page 34 Multimedia function license

☞ Page 34 VNC server function license

☞ Page 34 VPN connection function license

☞ Page 34 GT Works Text to Speech License

GOT Mobile function license for GOT3000

One license is required for each GOT used.

Model	No. of sales licenses	Delivery type
GT30-WEBSKEYA1N-1	1	Digital distribution
GT30-WEBSKEYA1-1	1	License certificate
GT30-WEBSKEYA1-5	5	License certificate

GOT Mobile function license for GT SoftGOT3000

One license is required for each OS on the personal computer running this product.

Model	No. of sales licenses	Delivery type
GT3S-WEBSKEYA1N-1	1	Digital distribution
GT3S-WEBSKEYA1-1	1	License certificate
GT3S-WEBSKEYA1-5	5	License certificate

License for the remote personal computer operation function (Ethernet)

One license is required for each GOT used.

Model	No. of sales licenses	Delivery type
GT30-PCRAKEYA1N-1	1	Digital distribution
GT30-PCRAKEYA1-1	1	License certificate
GT30-PCRAKEYA1-5	5	License certificate

Multimedia function license

One license is required for each GOT used.

Model	No. of sales licenses	Delivery type
GT30-MMRKEYA1N-1	1	Digital distribution
GT30-MMRKEYA1-1	1	License certificate
GT30-MMRKEYA1-5	5	License certificate

VNC server function license

One license is required for each GOT used.

Model	No. of sales licenses	Delivery type
GT30-VNCSKEYA1N-1	1	Digital distribution
GT30-VNCSKEYA1-1	1	License certificate
GT30-VNCSKEYA1-5	5	License certificate

VPN connection function license

One license is required for each GOT used.

Model	No. of sales licenses	Delivery type
GT30-VPNKEYA1N-1	1	Digital distribution
GT30-VPNKEYA1-1	1	License certificate
GT30-VPNKEYA1-5	5	License certificate

GT Works Text to Speech License

To edit sound files, each personal computer requires one license.

Model	No. of sales licenses	Delivery type
SW1DND-GTVO-M	1	License certificate
SW1DND-GTVO-ME	1	Digital distribution

4.5 Option

- ☞ Page 35 Protective sheet
- ☞ Page 35 Stand
- ☞ Page 35 SD card
- ☞ Page 35 Battery

4.5.1 Protective sheet

○: Usable, —: Not usable

Model	Description		Model
			GT37
GT37-15WPSGC	For 15.6" wide, capacitive type	Antiglare type Transparent A set of 2 sheets	○
GT37-12WPSGC	For 12.1" wide, capacitive type		
GT37-15PSGC	For 15"	Antiglare type Transparent A set of 5 sheets With a hole for the USB environmental protection cover	○
GT35-12PSGC	For 12.1"		
GT35-10PSGC	For 10.4"		
GT35-08PSGC	For 8.4"		
GT37-15WPSGC	For 15.6" wide, capacitive type	Clear type Transparent A set of 2 sheets	○
GT37-12WPSGC	For 12.1" wide, capacitive type		
GT37-15PSCC	For 15"	Clear type Transparent A set of 5 sheets With a hole for the USB environmental protection cover	○
GT35-12PSCC	For 12.1"		
GT35-10PSCC	For 10.4"		
GT35-08PSCC	For 8.4"		

4.5.2 Stand

○: Usable, —: Not usable

Model	Description	Model
		GT37
GT15-90STAND	For 15"	○
GT15-80STAND	For 12.1" wide/12.1"	
GT15-70STAND	For 10.4"/8.4"	

4.5.3 SD card

○: Usable, —: Not usable

Model	Description	Model
		GT37
NZ1MEM-2GBSD	2 GB SD memory card	○
NZ1MEM-4GBSD	4 GB SDHC memory card	
NZ1MEM-8GBSD	8 GB SDHC memory card	
NZ1MEM-16GBSD	16 GB SDHC memory card	

4.5.4 Battery

○: Usable, —: Not usable

Model	Description	Model
		GT37
GT11-50BAT	For clock data backup*1	○

*1 The clock data is used for functions such as logging.
To back up the clock data, purchase a battery.

4.6 Cable

Mitsubishi Electric PLC cable

Product name		Model	Cable length	Recommended product	Specifications
USB cable	Panel-mounted USB port extension ^{*1}	GT14-C10EXUSB-4S	1 m	—	For routing the USB 2.0 port on the rear of the GOT to the front of the control panel
Conversion unit, conversion cable	RS-485 terminal block conversion unit	FA-LTBGT2R4CBL05	0.5 m	○ ^{*3}	RS-485 terminal block conversion unit with a cable for connection between the RS-422/485 connector and the RS-485 terminal block conversion unit
		FA-LTBGT2R4CBL10	1 m		
		FA-LTBGT2R4CBL20	2 m		
	RS-422/232 connector conversion cable	GT35-C02HR2-9P	0.2 m	○ ^{*4}	Connector conversion cable for connecting an existing RS-232 cable [D-sub 9-pin ↔ D-sub 9-pin]
RS-422 connector conversion cable	FA-CNV2402CBL	0.2 m	○ ^{*3}	QCPU/L02SCPU(-P) ↔ RS-422 cable (GT01-C□R4-25P) L6ADP-R2 ↔ RS-422 cable (GT01-C□R4-25P) [MINI-DIN 6-pin ↔ D-sub 25-pin]	
	FA-CNV2405CBL	0.5 m			
RS-232 cable ^{*2}	Q/LCPU direct connection cable	GT01-C30R2-6P	3 m	—	Q/LCPU ↔ GOT L6ADP-R2 ↔ GOT/personal computer (GT SoftGOT3000) [MINI-DIN 6-pin ↔ D-sub 9-pin]
	Connection cable for the FXCPU communication function extension board Connection cable for the FXCPU communication special adapter	GT01-C30R2-9S	3 m	—	FXCPU communication function extension board ↔ GOT/personal computer (GT SoftGOT3000) FXCPU communication special adapter ↔ GOT/personal computer (GT SoftGOT3000) [D-sub 9-pin ↔ D-sub 9-pin]
		GT01-C30R2-25P	3 m	○	FXCPU communication special adapter ↔ GOT/personal computer (GT SoftGOT3000) [D-sub 25-pin ↔ D-sub 9-pin]
	Computer link connection cable CC-Link (G4) connection cable	GT09-C30R2-9P	3 m	○ ^{*4}	Serial communication module ↔ GOT Computer link module ↔ GOT Peripheral connection module (AJ65BT-R2N) ↔ GOT [D-sub 9-pin ↔ D-sub 9-pin]
		GT09-C30R2-25P	3 m	○ ^{*4}	Serial communication module ↔ GOT Computer link module ↔ GOT [D-sub 25-pin ↔ D-sub 9-pin]
RS-422 cable	QnA/A/FXCPU direct connection cable Computer link connection cable CC-Link (G4) connection cable	GT01-C30R4-25P	3 m	—	QnA/ACPU/Motion CPU (A series)/FXCPU ↔ GOT RS-422 connector conversion cable (FA-CNV□CBL) ↔ GOT Serial communication module ↔ GOT Peripheral connection module (AJ65BT-G4-S3) ↔ GOT [D-sub 25-pin ↔ D-sub 9-pin]
		GT01-C100R4-25P	10 m		
		GT01-C200R4-25P	20 m		
		GT01-C300R4-25P	30 m		
	Computer link connection cable	GT09-C30R4-6C	3 m	○ ^{*4}	Serial communication module ↔ GOT Computer link module ↔ GOT [Separate wire ↔ D-sub 9-pin]
		GT09-C100R4-6C	10 m		
		GT09-C200R4-6C	20 m		
		GT09-C300R4-6C	30 m		
	FXCPU direct connection cable Connection cable for the FXCPU communication function extension board	GT01-C10R4-8P	1 m	—	FXCPU ↔ GOT FXCPU communication function extension board ↔ GOT [MINI-DIN 8-pin ↔ D-sub 9-pin]
		GT01-C30R4-8P	3 m		
		GT01-C100R4-8P	10 m		
		GT01-C200R4-8P	20 m		
GT01-C300R4-8P		30 m			



- *1 For routing the USB interface (host) on the rear of the GOT to the front of the control panel.
For the external dimensions of the cable, refer to the following.
 Page 56 Communication cable
- *2 If an existing RS-232 cable is used, an RS-422 to RS-232 connector conversion cable (GT35-C02HR2-9P) is required separately.
- *3 Converter unit manufactured by Mitsubishi Electric Engineering Co., Ltd.
Purchase the product from your local sales office.
- *4 Manufactured by Mitsubishi Electric System & Service Co., Ltd.
Purchase the product from your local sales office.

4.7 Peripherals

For information on peripherals that have been validated by Mitsubishi Electric, refer to the relevant Technical Bulletin. For Technical Bulletins, go to the Mitsubishi Electric Factory Automation Global Website.

www.MitsubishiElectric.com/fa

When selecting peripherals, check the device specifications and perform thorough verification before use.

Product		Reference
SD card		For information on SD cards manufactured by Mitsubishi Electric, refer to the following.  Page 35 SD card
Barcode reader	RS-232 connection	For the validated models expect the SD cards, refer to the following Technical Bulletin.  List of Valid Devices Applicable for GOT3000 Series (GOT-D-0233)
	RS-422/485 connection	
	USB connection	
2D code reader	RS-232 connection	
	RS-422/485 connection	
	USB connection	
RFID controller	RS-232 connection	
	RS-422/485 connection	
	USB connection	
USB mouse		
USB keyboard		
Memory card reader/writer		
USB memory		
Switching hub* ¹		
USB hub		
USB cable		
Wireless LAN access point		
Video camera		
Speaker		

*1 Depending on the connected switching hub, even if the hub supports 1000BASE-T, there may be situations where connection (linkup) is not possible using 1000BASE-T.
 In such situations, remove and reinsert the Ethernet cable connected to the switching hub, or replace the switching hub with another one that supports 1000BASE-T.

4.7.1 Using multiple USB devices simultaneously

You can use USB devices such as a USB mouse and USB memory simultaneously via a USB hub connected to the USB interface (host) of the GOT.

For the settings of the USB interface (host), refer to the following manuals.

📖 GT Designer3 (GOT3000) Screen Design Manual

📖 GOT3000 Series User's Manual (Utility & Maintenance Functions)

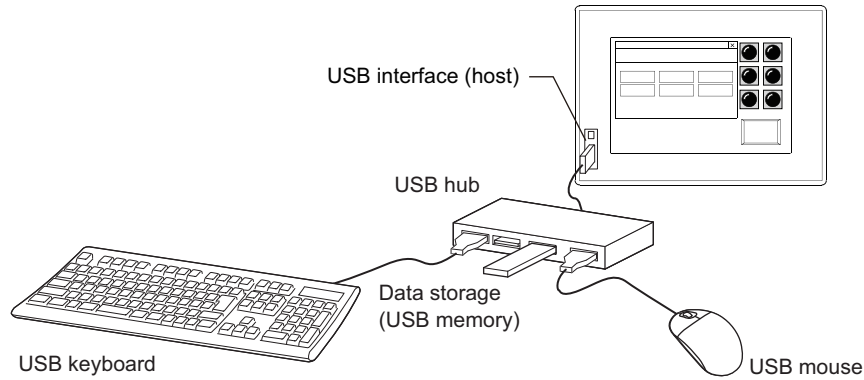

Item	Specifications
Number of USB devices that can be used	<p>A total of 12 devices (excluding USB hubs)</p> <ul style="list-style-type: none"> • Up to 4 USB devices (mouse, keyboard, etc.) assignable to GOT drives and channels • Up to 4 USB devices (memory) assignable to GOT drives • Up to 4 USB devices (audio, camera, etc.) assignable to channels <p>A total of 900 mA is allowed for USB devices connected to the front USB interface (USB Type-C) and the rear USB interface (USB Type-A).</p>
Usable USB hub ^{*1}	Up to 4 devices connected in cascade

^{*1} Some hubs with special functions are not supported.

Examples of special functions: hubs with five or more ports, hubs with multiple internal hubs, and composite devices with functions beyond those of a hub.

PART 3 Specifications

5 GOT3000 series common specifications

6 GT37

7 Battery

8 Communication cable

5

GOT3000 series common specifications

5.1 General specifications

This section describes the general specifications of the GOT.

Item	Specifications				
Ambient operating temperature ^{*1} Température ambiante de fonctionnement ^{*2}	0°C to 55°C ^{*3*5} 0 °C à 55 °C ^{*4*6}				
Ambient storage temperature	-20 °C to 60 °C				
Ambient operating humidity	10% RH to 90% RH, non-condensing				
Ambient storage humidity	10% RH to 90% RH, non-condensing				
Vibration resistance	Compliant with JIS B3502 and IEC 61131-2	Frequency	Acceleration	Amplitude	Sweep count
		5 Hz to 8.4 Hz	—	3.5 mm	X, Y, or Z
		8.4 Hz to 150 Hz	10m/s ²	—	10 times in each direction
Shock resistance	Compliant with JIS B3502 and IEC 61131-2 (150 m/s ² (15 G), 3 times in X, Y, or Z directions)				
Operating atmosphere	No greasy fumes, corrosive gas, flammable gas, excessive conductive dust, and direct sunlight (as well as at storage)				
Operating altitude ^{*7}	2000 m or less				
Installation location Emplacement d'installation	Inside control panel ^{*8} (used indoors) Tableau de commande intérieur ^{*9} (utilisé en intérieur)				
Overvoltage category ^{*10}	II or less				
Pollution degree ^{*11}	2 or less				
Cooling method	Self-cooling				
Grounding	Grounding with a ground resistance of 100 Ω or less by using a ground cable that has a cross-sectional area of 2 mm ² or more. If possible, connect the ground cable to the control panel.				

- *1 Indicates the temperature inside the enclosure of the control panel on which the GOT is installed.
- *2 La température ambiante de fonctionnement inclut la température à l'intérieur du boîtier du tableau de commande sur lequel le GOT est installé.
- *3 The operating ambient temperature of the GOT is specified as 0°C to 55°C at an altitude of 0 m.
Use the following formula to calculate the ambient operating temperature at different altitudes.
Ambient operating temperature = 55 [°C] - 0.005 × altitude [m]
- *4 La température ambiante de fonctionnement du GOT est indiquée entre 0 °C et 55 °C à une hauteur de 0 m.
Calculez la température ambiante de fonctionnement à différentes hauteurs à l'aide de la formule suivante.
Température ambiante de fonctionnement = 55 [°C] - 0,005 × hauteur [m]
- *5 When any of the following units is installed, the maximum ambient operating temperature must be 5°C lower than the one described in the general specifications.
MELSECNET/H communication unit (GT15-J71LP23-25, GT15-J71BR13)
CC-Link communication unit (GT15-J61BT13)
- *6 Lorsque l'une des unités suivantes est installée, la température ambiante de fonctionnement maximale doit être inférieure de 5 °C à celle décrite dans les caractéristiques générales.
Unité de communication MELSECNET/H (GT15-J71LP23-25, GT15-J71BR13)
Unité de communication CC-Link (GT15-J61BT13)
- *7 Do not use or store the GOT under a pressure higher than the atmospheric pressure at an altitude 0 m.
Doing so may cause a malfunction.
Air purging by applying pressure to the control panel may create clearance between the surface sheet and the touch panel. This may cause the touch panel to be not sensitive enough or the sheet to come off.
- *8 Install the GOT in an IP20-compliant enclosure that is appropriately designed to meet the specific environmental conditions.
The UL test has not been performed for the IP protection rating.
- *9 Installez le GOT dans une enceinte conforme à la norme IP20 et conçue pour répondre aux conditions environnementales spécifiques.
Le test UL n'a pas été effectué pour l'indice de protection IP.
- *10 This indicates the power distribution section to which the equipment is assumed to be connected, between the public power grid and the machinery within the premises.
Category II applies to equipment for which electrical power is supplied from fixed facilities.
The withstand surge voltage for the equipment with the rated voltage up to 300 V is 2500 V.
- *11 This indicates the occurrence rate of conductive material in an environment where a device is used.
Pollution degree 2 indicates an environment where only non-conductive pollution occurs normally and a temporary conductivity caused by condensation shall be expected depending on the conditions.

6

GT37



6.1

GT3715-FH, GT3712-WX

6.1.1

Performance specifications

Item		Specifications	
		GT3715-FHCBD	GT3712-WXCBD
Display section ^{*1*2}	Display device	TFT color LCD	
	Screen size	15.6" wide	12.1" wide
	Resolution	Full HD: 1920 × 1080 dots	WXGA: 1280 × 800 dots
	Display size	344.2 (13.55) (W) × 193.6 (7.62) (H) mm (in.)	261.1 (10.28) (W) × 163.2 (6.43) (H) mm (in.)
	Display color	16 million colors	
	Brightness adjustment	32 levels (switchable between normal mode and low brightness mode)	
	Backlight	LED (Not replaceable)	
	Backlight life ^{*3}	50000 h or more (time it takes for the display intensity to reach 50% at an ambient operating temperature of 25°C)	
Touch panel ^{*4}	Type	Capacitive type ^{*5*6*7}	
	Simultaneous press	Up to two points	
	Life	—	
Memory capacity	<ul style="list-style-type: none"> • ROM: 512 MB • RAM: 2 GB 		
User memory capacity	<ul style="list-style-type: none"> • Memory for storage (ROM): 256 MB^{*8} • Memory for operation (RAM): 768 MB 		
Built-in clock precision	±90 seconds/month (Ambient temperature: 25°C)		
Battery	<p>The battery is sold separately. If you use a battery, purchase the following battery.</p> <ul style="list-style-type: none"> • GT11-50BAT lithium battery <p>For details on the battery, refer to the following. ☞ Page 55 Battery</p>		
Built-in interface	RS-232/422/485	<ul style="list-style-type: none"> • 1 channel • Transmission speed: 115200, 57600, 38400, 19200, 9600, 4800 bps • Connector shape: D-sub 9-pin (female), M2.6 metric screw thread • Switching between RS-232 and RS-422/485: Set with GT Works3 or the utility <p>For the connector pin layout, refer to the following. 📖 GOT3000 Series User's Manual (Connection)</p>	
	Ethernet	<ul style="list-style-type: none"> • 2 channels • Transmission method: 1000BASE-T, 100BASE-TX, 10BASE-T • Connector shape: RJ45 (modular jack) • AUTO MDI/MDI-X 	
	USB (device/host)	<ul style="list-style-type: none"> • 1 channel (front face) • USB version: USB 3.2 Gen1 (USB 3.0) (SuperSpeed 5 Gbps) • Connector shape: USB Type-C 	
	USB (host)	<ul style="list-style-type: none"> • 1 channel (rear face) • USB version: USB 3.2 Gen1 (USB 3.0) (SuperSpeed 5 Gbps) • Connector shape: USB Type-A 	
	Digital video output	<ul style="list-style-type: none"> • 1 channel • Connector shape: HDMI Type A connector 	
	SD card ^{*9}	<ul style="list-style-type: none"> • 1 channel • SDHC compliant (maximum 32 GB) 	
	Contactless tag ^{*10}	<ul style="list-style-type: none"> • 1 channel • Compliance standards: ISO/IEC 15693 (Type 5 tag) 	
	Extension interface	For installing a communication unit or an option unit	
Buzzer sound	Single tone (tone and tone length adjustable)		
Power LED	1 color (lime green)		
Panel color	Black		
Protective structure ^{*11}	<ul style="list-style-type: none"> • Front: IP66F^{*12}, IP67F^{*12*13}, NEMA Type 4X • Enclosure interior: IP2X 		

Item	Specifications	
	GT3715-FHCBD	GT3712-WXCBD
External dimensions	 Page 45 GT3715-FH	 Page 45 GT3712-WX
Panel cutting dimensions	 Page 46 Panel cutting dimensions	
Weight (excluding the installation fittings)	2.7 (6.0) kg (lb.)	2.1 (4.6) kg (lb.)
Compatible software package	GT Works3 version 1.400S or later	

- *1 As a characteristic of liquid crystal display panels, bright dots (always lit) and dark dots (never lit) may appear on the panel. Since liquid crystal display panels comprise a great number of display elements, the appearance of bright and dark dots cannot be reduced to zero.
Individual differences in liquid crystal display panels may cause differences in color, uneven brightness and flickering.
Note that these phenomena are characteristics of liquid crystal display panels and it does not mean the products are defective or damaged.
- *2 Flickering may occur due to vibration, shock, or the display colors.
- *3 To prevent the display section from burning in or lengthen the backlight life, enable the screen save function and turn off the backlight.
- *4 Switches with a minimum size of 2 × 2 dots can be placed.
The following settings are recommended for safe use.
- Key size: 48 × 48 dots or larger
 - Key spacing: 24 dots or more
- *5 If water, oil, or any other conductive material adheres to the GOT display, the GOT may malfunction.
In such a case, wipe it off before use.
- *6 When using a stylus, use a capacitive (passive) type.
- *7 To prevent a significant deterioration in the response and operability of the touch panel, be sure to ground the FG terminal of the GOT at one point.
For information on grounding, refer to the following.
 Page 105 Grounding
- *8 If the GOT is turned off while data is being written to the storage memory (ROM), the data may be corrupted and the GOT may become inoperable.
- *9 If the GOT is turned off while data is being written to the SD card, the data may be corrupted and the GOT may become inoperable.
- *10 The communication distance will vary depending on the reader/writer used for contactless communication.
If communication is not possible, move the reader/writer as close as possible to the contactless tag on the front of the GOT.
Ensure that the reader/writer does not touch the GOT display when performing contactless communication.
If the reader/writer accidentally touches the touch switches on the display, malfunction may occur.
- *11 Note that the structure does not guarantee protection in all user environments.
The GOT should not be used in environments where it may be exposed to oil or chemicals for a long period of time, or where oil mist fills the air.
The UL test has not been performed for the IP protection rating.
- *12 The suffix "F" of IP66F and IP67F is a symbol that indicates protection rate against oil.
The symbol is found in the Appendix of the Japanese Industrial Standard JIS C 0920.
- *13 The GOT is IP67F-rated when the USB environmental protection cover is closed by pushing the Δ mark firmly.
The GOT conforms to IP2X when the USB environmental protection cover is open.

6.1.2 Specifications of the power supply section

The following shows the power supply specifications of the GOT.

Point

Operation at instantaneous power failure

If an instantaneous power failure occurs in the power supply and continues for more than the permissible period, the GOT may be reset.

Make sure to power on the unit more than 5 seconds after power-off.

Input power supply 24 V DC

Item	Specifications		
	GT3715-FHCBD	GT3712-WXCBD	
Power supply voltage ^{*1}	24 V DC (+25%, -20%)		
Power consumption	Under the maximum load	42 W or less	37 W or less
	Main unit (reference value)	20 W	15 W
Inrush current	5 A or less (20 ms, ambient temperature: 25°C, under the maximum load)		
Permissible instantaneous power failure time	10 ms or less		
Noise immunity	Noise voltage: 2 kV (compliant with IEC 61000-4-4)		
Withstand voltage	510 V AC for 1 minute across power supply terminals and earth		
Insulation resistance	500 V DC across power supply terminals and earth, 10 MΩ or more by an insulation resistance tester		
Applicable wire	Size	0.75 mm ² to 2 mm ² (AWG 18 to AWG 14)	
	Type	Stranded wire	
	Material	Copper wire	
	Temperature rating	75 °C or higher	
Applicable solderless terminal	Solderless terminal for M3 screw: RAA1.25-3, V2-S3.3, V2-N3A, FV2-N3A		
Applicable tightening torque (for terminal block terminal screws)	0.5 N·m to 0.8 N·m		

*1 Power this equipment from a power supply that meets SELV (Safety Extra-Low Voltage) and meets LIM (Limited Energy Circuit) or UL 1310 Class 2.

6.1.3 External dimensions

GT3715-FH

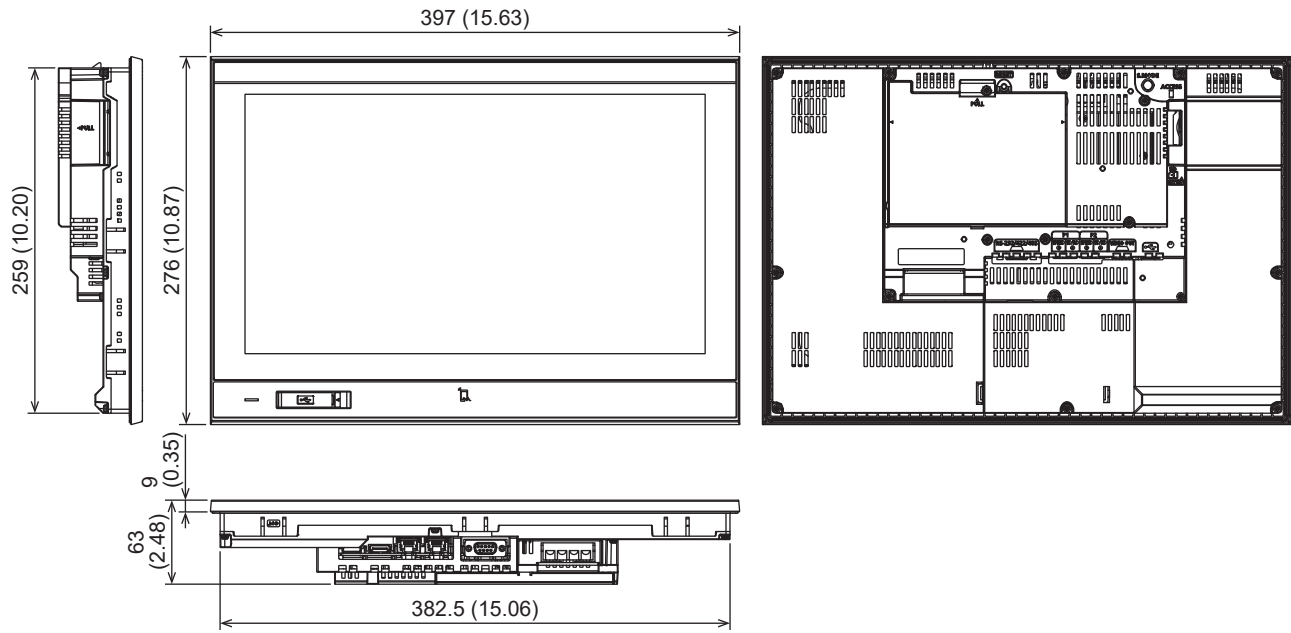

Unit: mm (in.)

GT3712-WX

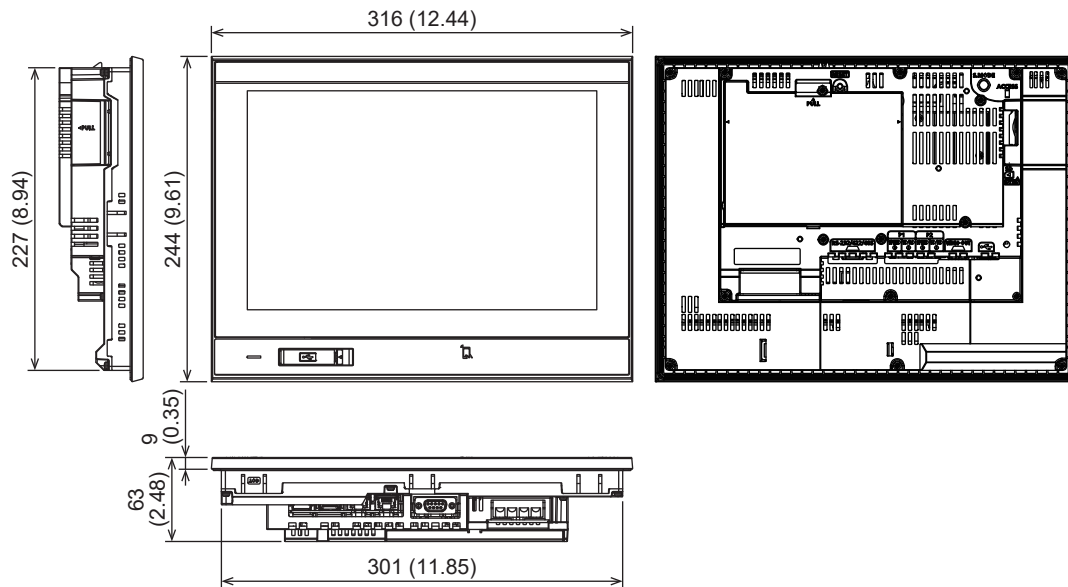

Unit: mm (in.)

6.1.4 Panel cutting dimensions

Open an installation hole on the control panel with the dimensions shown below.

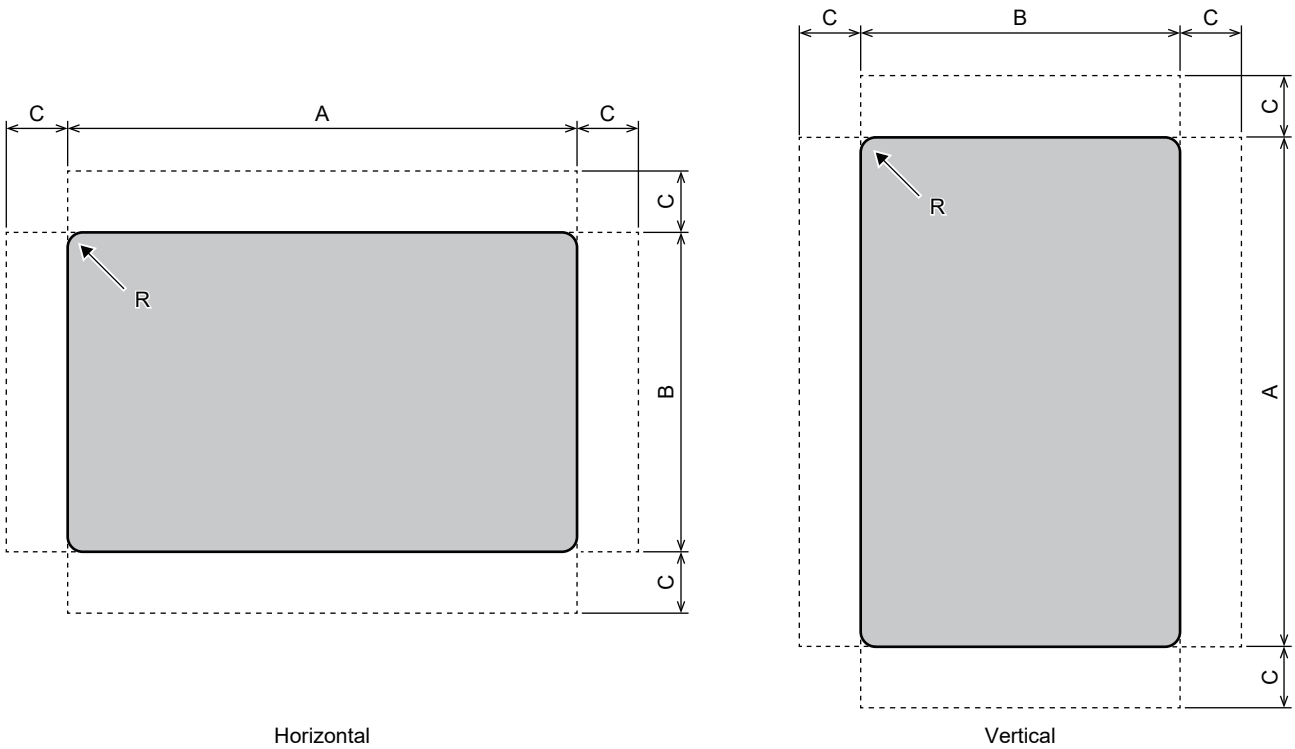

Unit: mm (in.)



Model	A	B	C	R	Panel thickness
GT3715-FHCB	383.5 (15.1) ^{+1 (0.04)} _{0 (0)}	260 (10.24) ^{+1 (0.04)} _{0 (0)}	15 (0.59) or more	2 (0.08) or less	1.6 (0.063) to 4 (0.157)
GT3712-WXCB	302 (11.89) ^{+1 (0.04)} _{0 (0)}	228 (8.98) ^{+1 (0.04)} _{0 (0)}			

Dimension C is required for installing fittings on the control panel.

6.2

GT3715-X, GT3712-X, GT3710-X, GT3708-X

6.2.1 Performance specifications

Item	Specifications				
	• GT3715-XRBA • GT3715-XRBD	• GT3712-XRBA • GT3712-XRBD	• GT3710-XRBA • GT3710-XRBD	• GT3708-XRBA • GT3708-XRBD	
Display section ^{*12}	Display device	TFT color LCD			
	Screen size	15"	12.1"	10.4"	8.4"
	Resolution	XGA: 1024 × 768 dots			
	Display size	304.1 (11.97) (W) × 228.1 (8.98) (H) mm (in.)	246.0 (9.69) (W) × 184.5 (7.26) (H) mm (in.)	211.2 (8.31) (W) × 158.4 (6.24) (H) mm (in.)	170.9 (6.73) (W) × 128.2 (5.05) (H) mm (in.)
	Display color	16 million colors			
	Brightness adjustment	32 levels (switchable between normal mode and low brightness mode)			
	Backlight	LED (Not replaceable)			
	Backlight life ^{*3}	50000 h or more (time it takes for the display intensity to reach 50% at an ambient operating temperature of 25°C)			
Touch panel ^{*4}	Type	Analog resistive film ^{*56}			
	Simultaneous press	Not available (Only 1 point can be touched.) ^{*7}			
	Life	1 million touches or more (Operating force: 0.98 N or less)			
Human sensor ^{*8}	Detection method	Pyroelectric type	—	—	
	Detection length	1 m	—	—	
	Detection temperature	Temperature difference between human body and ambient air: 4°C or higher	—	—	
Memory capacity	<ul style="list-style-type: none"> • ROM: 512 MB • RAM: 2 GB 				
User memory capacity	<ul style="list-style-type: none"> • Memory for storage (ROM): 256 MB^{*9} • Memory for operation (RAM): 768 MB 				
Built-in clock precision	±90 seconds/month (Ambient temperature: 25°C)				
Battery	<p>The battery is sold separately.</p> <p>If you use a battery, purchase the following battery.</p> <ul style="list-style-type: none"> • GT11-50BAT lithium battery <p>For details on the battery, refer to the following.</p> <p> Page 55 Battery</p>				
Built-in interface	RS-232/422/485	<ul style="list-style-type: none"> • 1 channel • Transmission speed: 115200, 57600, 38400, 19200, 9600, 4800 bps • Connector shape: D-sub 9-pin (female), M2.6 metric screw thread • Switching between RS-232 and RS-422/485: Set with GT Works3 or the utility <p>For the connector pin layout, refer to the following.</p> <p> GOT3000 Series User's Manual (Connection)</p>			
	Ethernet	<ul style="list-style-type: none"> • 2 channels • Transmission method: 1000BASE-T, 100BASE-TX, 10BASE-T • Connector shape: RJ45 (modular jack) • AUTO MDI/MDI-X 			
	USB (device/host)	<ul style="list-style-type: none"> • 1 channel (front face) • USB version: USB 3.2 Gen1 (USB 3.0) (SuperSpeed 5 Gbps) • Connector shape: USB Type-C 			
	USB (host)	<ul style="list-style-type: none"> • 1 channel (rear face) • USB version: USB 3.2 Gen1 (USB 3.0) (SuperSpeed 5 Gbps) • Connector shape: USB Type-A 			
	Digital video output	<ul style="list-style-type: none"> • 1 channel • Connector shape: HDMI Type A connector 			
	SD card ^{*10}	<ul style="list-style-type: none"> • 1 channel • SDHC compliant (maximum 32 GB) 			
	Contactless tag ^{*11}	<ul style="list-style-type: none"> • 1 channel • Compliance standards: ISO/IEC 15693 (Type 5 tag) 			
	Extension interface	For installing a communication unit or an option unit			
Buzzer sound	Single tone (tone and tone length adjustable)				
Power LED	1 color (lime green)				

Item	Specifications			
	• GT3715-XRBA • GT3715-XRBD	• GT3712-XRBA • GT3712-XRBD	• GT3710-XRBA • GT3710-XRBD	• GT3708-XRBA • GT3708-XRBD
Panel color	Black			
Protective structure *12	<ul style="list-style-type: none"> • Front: IP66F*13, IP67F*13*14, NEMA Type 4X • Enclosure interior: IP2X 			
External dimensions	☞ Page 51 GT3715-X	☞ Page 51 GT3712-X	☞ Page 52 GT3710-X	☞ Page 53 GT3708-X
Panel cutting dimensions	☞ Page 54 Panel cutting dimensions			
Weight (excluding the installation fittings)	2.8 (6.2) kg (lb.)	2.0 (4.4) kg (lb.)	1.8 (4.0) kg (lb.)	1.5 (3.3) kg (lb.)
Compatible software package	GT Works3 version 1.400S or later			

- *1 As a characteristic of liquid crystal display panels, bright dots (always lit) and dark dots (never lit) may appear on the panel. Since liquid crystal display panels comprise a great number of display elements, the appearance of bright and dark dots cannot be reduced to zero.
Individual differences in liquid crystal display panels may cause differences in color, uneven brightness and flickering.
Note that these phenomena are characteristics of liquid crystal display panels and it does not mean the products are defective or damaged.
- *2 Flickering may occur due to vibration, shock, or the display colors.
- *3 To prevent the display section from burning in or lengthen the backlight life, enable the screen save function and turn off the backlight.
- *4 Switches with a minimum size of 2 × 2 dots can be placed.
The following settings are recommended for safe use.
- Key size: 48 × 48 dots or larger
 - Key spacing: 24 dots or more
- *5 When a stylus is used, the touch panel has a life of 100 thousand touches.
The stylus must satisfy the following specifications.
- Material: Polyacetal resin
 - Tip radius: 0.8 mm or more
- *6 Repeated operations on the edges of the touch panel (perimeter of the display section) may cause malfunction.
- *7 If you touch two points or more simultaneously on the touch panel, a switch in an unintended location may operate.
Do not touch two points or more simultaneously on the touch panel.
- *8 A human body hardly moving, moving toward the GOT front face, or moving rapidly may not be detected.
Heat sources other than human bodies may be detected.
Static electricity, electrical noises, and infrared rays can cause a false reaction.
- *9 If the GOT is turned off while data is being written to the storage memory (ROM), the data may be corrupted and the GOT may become inoperable.
- *10 If the GOT is turned off while data is being written to the SD card, the data may be corrupted and the GOT may become inoperable.
- *11 The communication distance will vary depending on the reader/writer used for contactless communication.
If communication is not possible, move the reader/writer as close as possible to the contactless tag on the front of the GOT.
Ensure that the reader/writer does not touch the GOT display when performing contactless communication.
If the reader/writer accidentally touches the touch switches on the display, malfunction may occur.
- *12 Note that the structure does not guarantee protection in all user environments.
The GOT should not be used in environments where it may be exposed to oil or chemicals for a long period of time, or where oil mist fills the air.
The UL test has not been performed for the IP protection rating.
- *13 The suffix "F" of IP66F and IP67F is a symbol that indicates protection rate against oil.
The symbol is found in the Appendix of the Japanese Industrial Standard JIS C 0920.
- *14 The GOT is IP67F-rated when the USB environmental protection cover is closed by pushing the △ mark firmly.
The GOT conforms to IP2X when the USB environmental protection cover is open.

6.2.2 Specifications of the power supply section

The following shows the power supply specifications of the GOT.

Point

Operation at instantaneous power failure

If an instantaneous power failure occurs in the power supply and continues for more than the permissible period, the GOT may be reset.

Make sure to power on the unit more than 5 seconds after power-off.

Input power supply 100 V AC to 240 V AC

Item		Specifications			
		GT3715-XRBA	GT3712-XRBA	GT3710-XRBA	GT3708-XRBA
Power supply voltage		100 V AC to 240 V AC (+10%, -15%)			
Power supply frequency		50 Hz/60 Hz (±5%)			
Maximum apparent power		100 VA		90 VA	
Power consumption	Under the maximum load	45 W or less		39 W or less	38 W or less
	Main unit (reference value)	19 W		15 W	
Inrush current		66 A or less (2 ms, ambient temperature: 25°C, under the maximum load)			
Permissible instantaneous power failure time		20 ms or less (100 V AC or more)			
Noise immunity		Noise voltage: 2 kV (compliant with IEC 61000-4-4)			
Withstand voltage		3000 V AC for 1 minute across power supply terminals and earth			
Insulation resistance		500 V DC across power supply terminals and earth, 10 MΩ or more by an insulation resistance tester			
Applicable wire	Size	0.75 mm ² to 2 mm ² (AWG 18 to AWG 14)			
	Type	Stranded wire			
	Material	Copper wire			
	Temperature rating	75 °C or higher			
Applicable solderless terminal		Solderless terminal for M3 screw: RAA1.25-3, V2-S3.3, V2-N3A, FV2-N3A			
Applicable tightening torque (for terminal block terminal screws)		0.5 N·m to 0.8 N·m			

Input power supply 24 V DC

Item		Specifications			
		GT3715-XRBD	GT3712-XRBD	GT3710-XRBD	GT3708-XRBD
Power supply voltage ^{*1}		24 V DC (+25%, -20%)			
Power consumption	Under the maximum load	39 W or less		33 W or less	
	Main unit (reference value)	17 W		12 W	
Inrush current		5 A or less (20 ms, ambient temperature: 25°C, under the maximum load)			
Permissible instantaneous power failure time		10 ms or less			
Noise immunity		Noise voltage: 2 kV (compliant with IEC 61000-4-4)			
Withstand voltage		510 V AC for 1 minute across power supply terminals and earth			
Insulation resistance		500 V DC across power supply terminals and earth, 10 MΩ or more by an insulation resistance tester			
Applicable wire	Size	0.75 mm ² to 2 mm ² (AWG 18 to AWG 14)			
	Type	Stranded wire			
	Material	Copper wire			
	Temperature rating	75 °C or higher			
Applicable solderless terminal		Solderless terminal for M3 screw: RAA1.25-3, V2-S3.3, V2-N3A, FV2-N3A			
Applicable tightening torque (for terminal block terminal screws)		0.5 N·m to 0.8 N·m			

*1 Power this equipment from a power supply that meets SELV (Safety Extra-Low Voltage) and meets LIM (Limited Energy Circuit) or UL 1310 Class 2.

6.2.3 External dimensions

GT3715-X

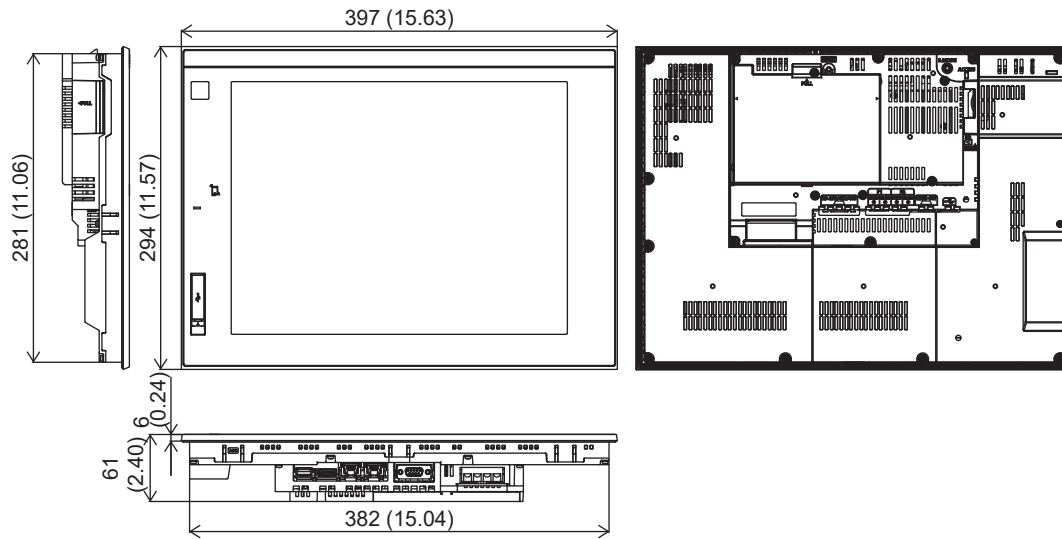

Unit: mm (in.)

GT3712-X

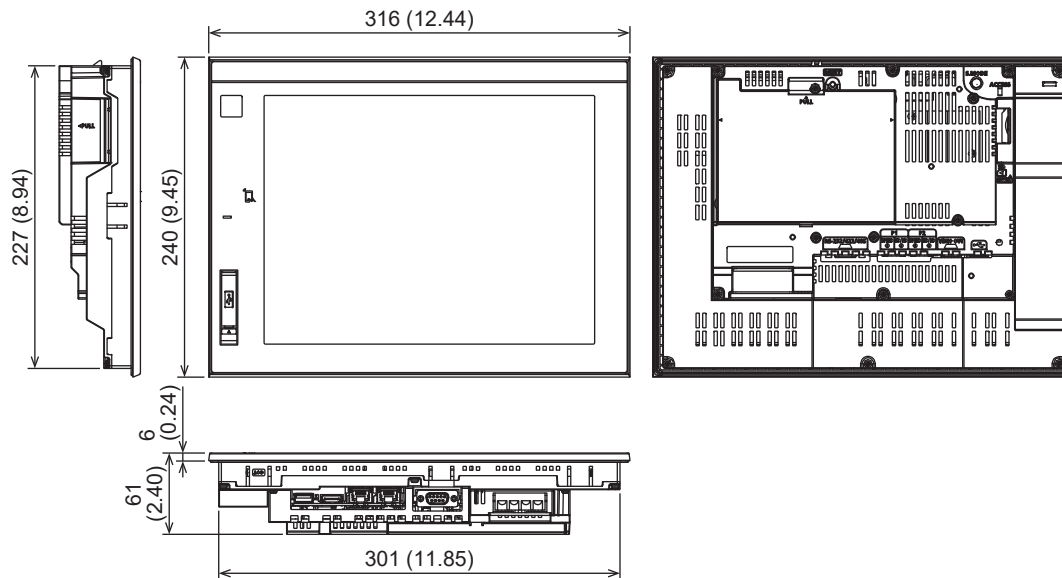

Unit: mm (in.)

GT3710-X

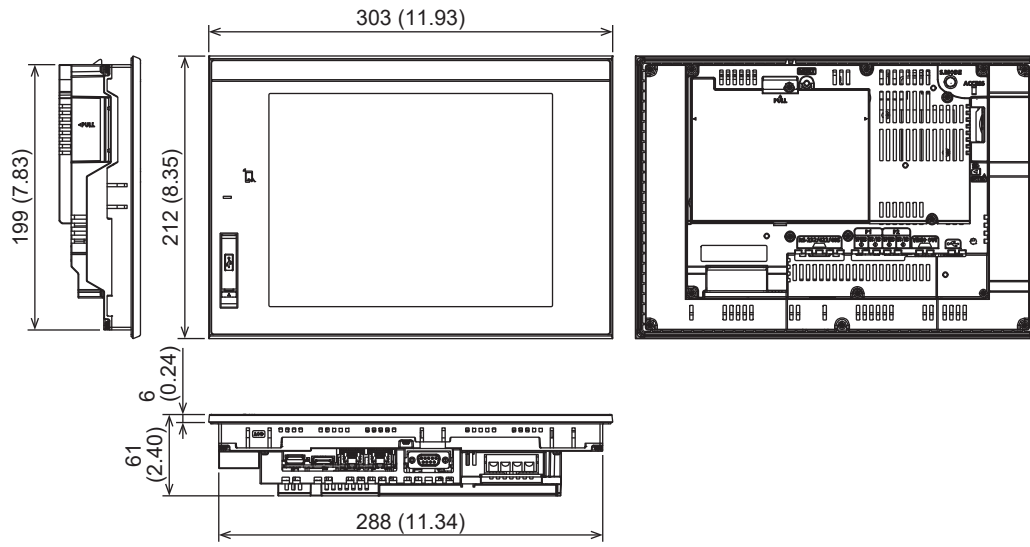

Unit: mm (in.)

GT3708-X

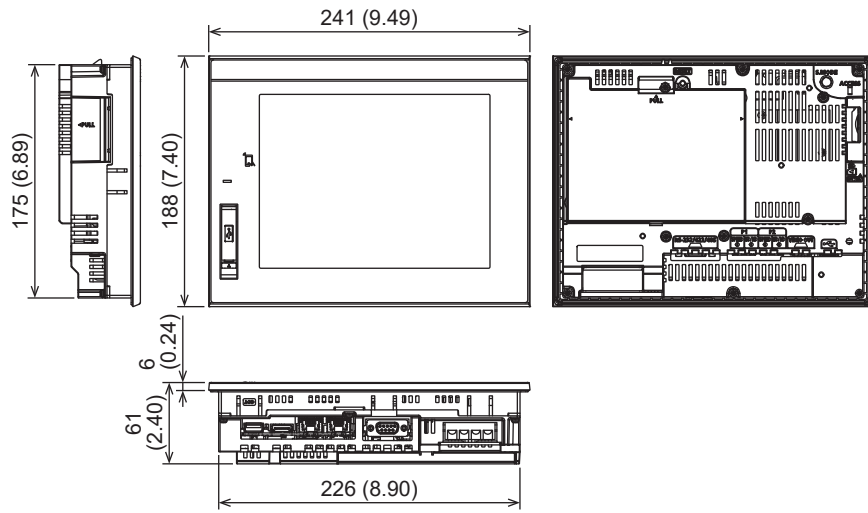

Unit: mm (in.)

6.2.4 Panel cutting dimensions

Open an installation hole on the control panel with the dimensions shown below.

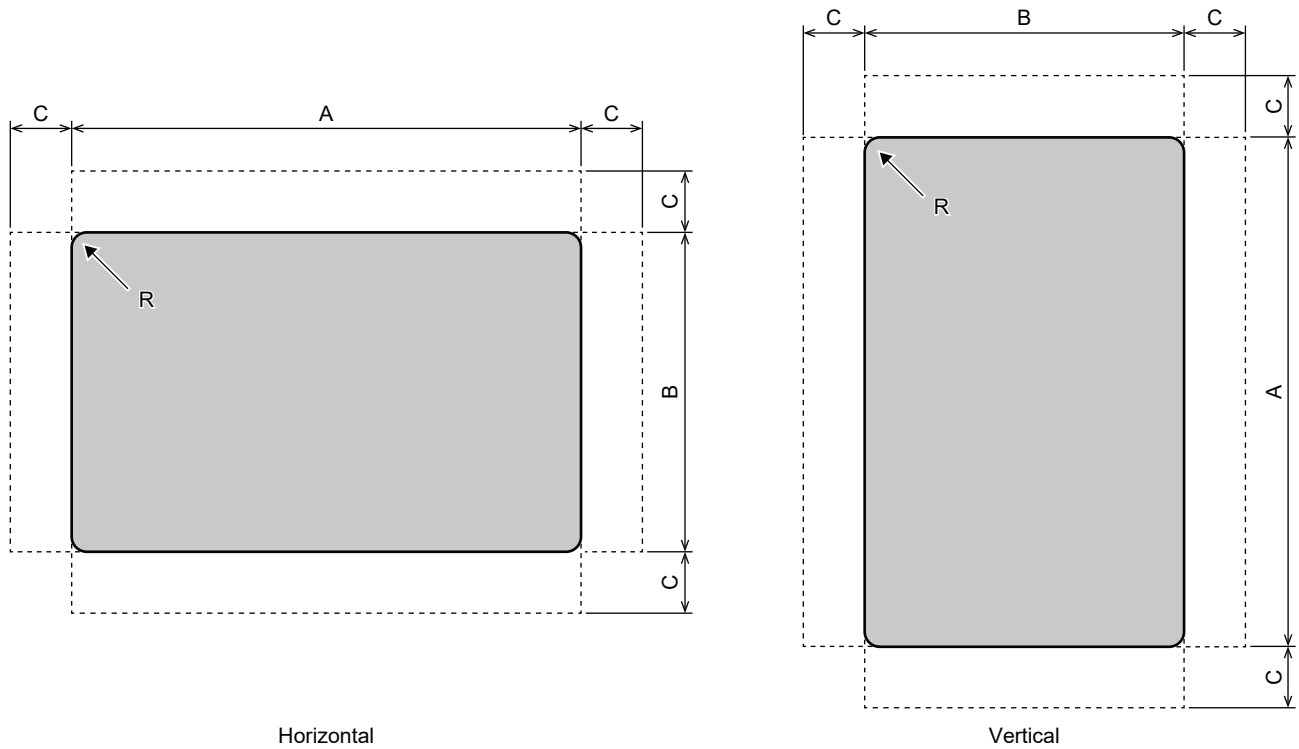

Unit: mm (in.)

Model	A	B	C	R	Panel thickness
<ul style="list-style-type: none"> • GT3715-XRBA • GT3715-XRBD 	383.5 (15.10) ^{+1 (0.04)} _{0 (0)}	282.5 (11.12) ^{+1 (0.04)} _{0 (0)}	15 (0.59) or more	2 (0.08) or less	1.6 (0.063) to 4 (0.157)
<ul style="list-style-type: none"> • GT3712-XRBA • GT3712-XRBD 	302 (11.89) ^{+1 (0.04)} _{0 (0)}	228 (8.98) ^{+1 (0.04)} _{0 (0)}			
<ul style="list-style-type: none"> • GT3710-XRBA • GT3710-XRBD 	289 (11.38) ^{+1 (0.04)} _{0 (0)}	200 (7.87) ^{+1 (0.04)} _{0 (0)}			
<ul style="list-style-type: none"> • GT3708-XRBA • GT3708-XRBD 	227 (8.94) ^{+1 (0.04)} _{0 (0)}	176 (6.93) ^{+1 (0.04)} _{0 (0)}			

Dimension C is required for installing fittings on the control panel.

7

Battery

Type

Use the battery shown below.

Model	Description	Supported model
GT11-50BAT (Sold separately)	Battery for clock data backup	GT37

Specifications

The following shows the battery specifications.

Item	Specifications
	GT11-50BAT
Type	Manganese dioxide lithium primary battery
Initial voltage	3.0 V
Nominal current	550 mAh
Storage life	Approx. 5 years (Ambient temperature: 25°C)
Total power stoppage time	5 years
Data retention period after low voltage detection ^{*1}	14 days
Battery replacement time	5 minutes or less
Lithium content	0.15 g

*1 In the following conditions, the data retention period is 5 minutes after power-off.
The battery connector is disconnected.
A battery lead is broken.

Point

For regulations on batteries within EU member states, refer to the following.

 Page 120 Handling of batteries and devices with built-in batteries in EU member states

8 Communication cable

8.1 Panel-mounted USB port extension

8.1.1 External dimensions

GT14-C10EXUSB-4S

Cable length: 1 m (3.3 ft)

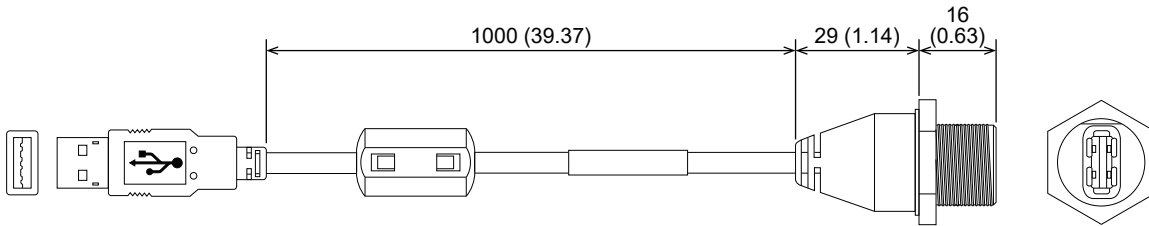

Unit: mm (in.)

PART 4

Part names and settings

9 GT37



9.1 GT3715-FH, GT3712-WX

The rear face of the GOT is shown with the cover removed.

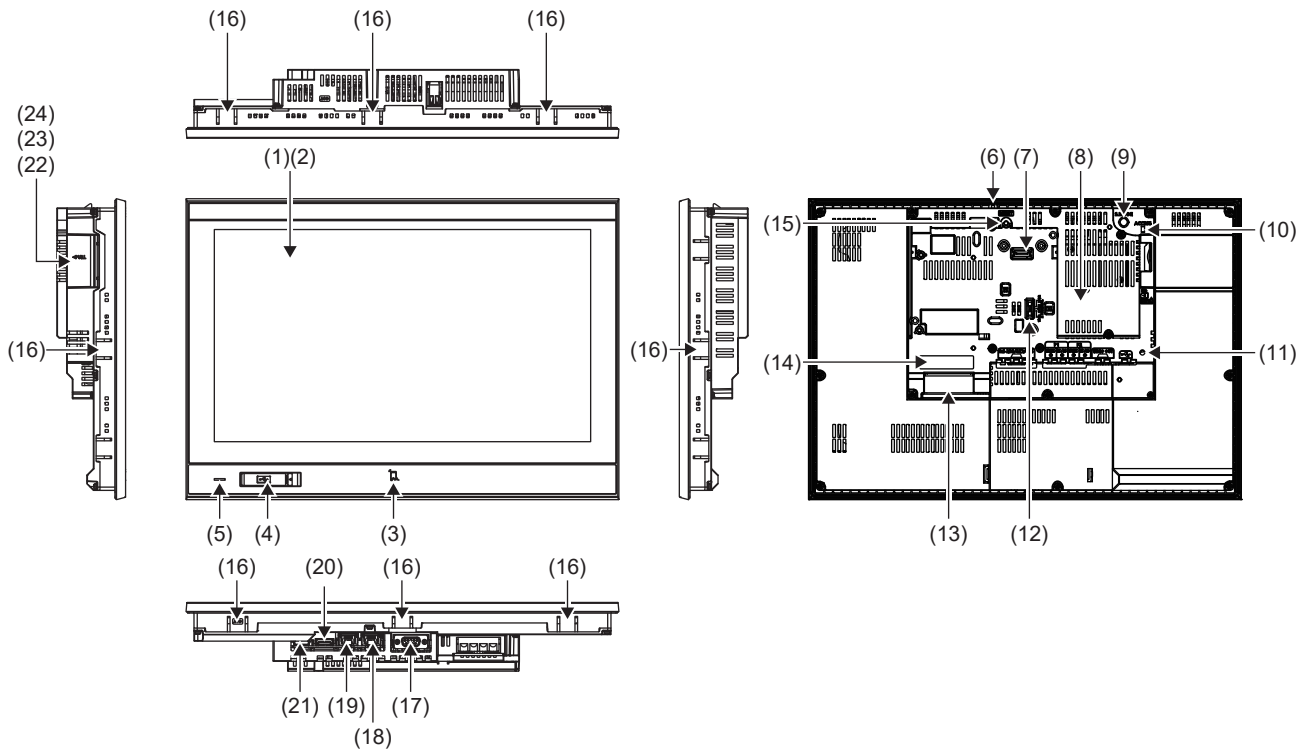
This section describes the part names using GT3715-FH as an example.



No.	Name	Description
(1)	Display section	For displaying the utility and user-created screens
(2)	Touch panel	For operating the touch switches in the utility and the user-created screen
(3)	Contactless tag	For contactless communication with mobile devices
(4)	Front USB interface (device/host)	For connecting a USB device or a personal computer (connector shape: USB Type-C)
(5)	Power LED	<ul style="list-style-type: none"> • Lit: Power is supplied. • Blinking (fade-in/fade-out): Screen saver is active. • Blinking: Backlight has failed. • Unlit: Power is not supplied.
(6)	Temporary fixing hook	A hook to prevent the GOT from falling from the control panel when installed
(7)	Extension interface	For installing a communication unit or an option unit
(8)	Rating plate	⚠ : Instructs the use of copper wire with an appropriate temperature rating (75°C or higher) for wiring and alerts users to exercise caution during battery replacement. *1
(9)	S.MODE switch	For installing the OS at GOT startup
(10)	SD card access LED	<ul style="list-style-type: none"> • Lit: SD card is inserted. • Blinking: SD card is being accessed. • Unlit: SD card is not inserted, or the inserted SD card is ready to be removed.
(11)	Cable clamp installation hole	For installing a cable clamp to prevent the video output cable or USB cable from being accidentally pulled out
(12)	Terminating resistor setting switch	For switching the terminating resistor for the RS-422/485 communication between 330 Ω, 100 Ω, and initial setting (unused).
(13)	Power supply terminal	Power input terminal, FG terminal, LG terminal

No.	Name	Description
(14)	Power supply terminal indication	<ul style="list-style-type: none"> ⏏ (For DC input only): Indicates the position of the DC power input terminal. The power supply varies depending on the input power type.  Page 44 Specifications of the power supply section ⏏ Functional grounding symbol: Indicates the functional ground terminal.
(15)	Reset switch	Hardware reset switch
(16)	Holes for the GOT installation fittings	Holes for installing the fittings used to secure the GOT to the panel
(17)	RS-232/422/485 interface	<p>For communications with a controller (connector shape: D-sub 9-pin (socket), M2.6 metric screw thread)</p> <p>For the connector pin layout, refer to the following.  GOT3000 Series User's Manual (Connection)</p> <p>When using RS-422/485 communication, set the terminating resistor with the terminating resistor setting switch.</p>
(18)	Ethernet interface (port 1)	For communicating with a controller or connecting a personal computer (connector shape: RJ45 (modular jack))
(19)	Ethernet interface (port 2)	
(20)	Digital video output interface	For outputting a digital video
(21)	Rear face USB interface (host)	For connecting a USB device (connector shape: USB Type- A)
(22)	SD card cover	<p>Provided with the switch function that allows or prohibits access to the SD card from the GOT.</p> <ul style="list-style-type: none"> • When the SD card cover is open: Access is prohibited. • When the SD card cover is closed: Access is allowed.
(23)	SD card interface (inside the SD card cover)	For installing an SD card
(24)	Battery storage area (inside the SD card cover)	Space for housing the battery

*1 Leave the GOT on for more than 10 minutes before replacing the battery.

Replace the battery within five minutes.

 Page 82 Installing and removing the battery

Be sure to use the GT11-50BAT.

 Page 55 Battery

Replacing the battery with an incorrect one may cause an explosion.

Dispose of the used battery according to the instructions.

9.2

GT3715-X, GT3712-X, GT3710-X, GT3708-X

The rear face of the GOT is shown with the cover removed.

This section describes the part names using GT3715-X as an example.

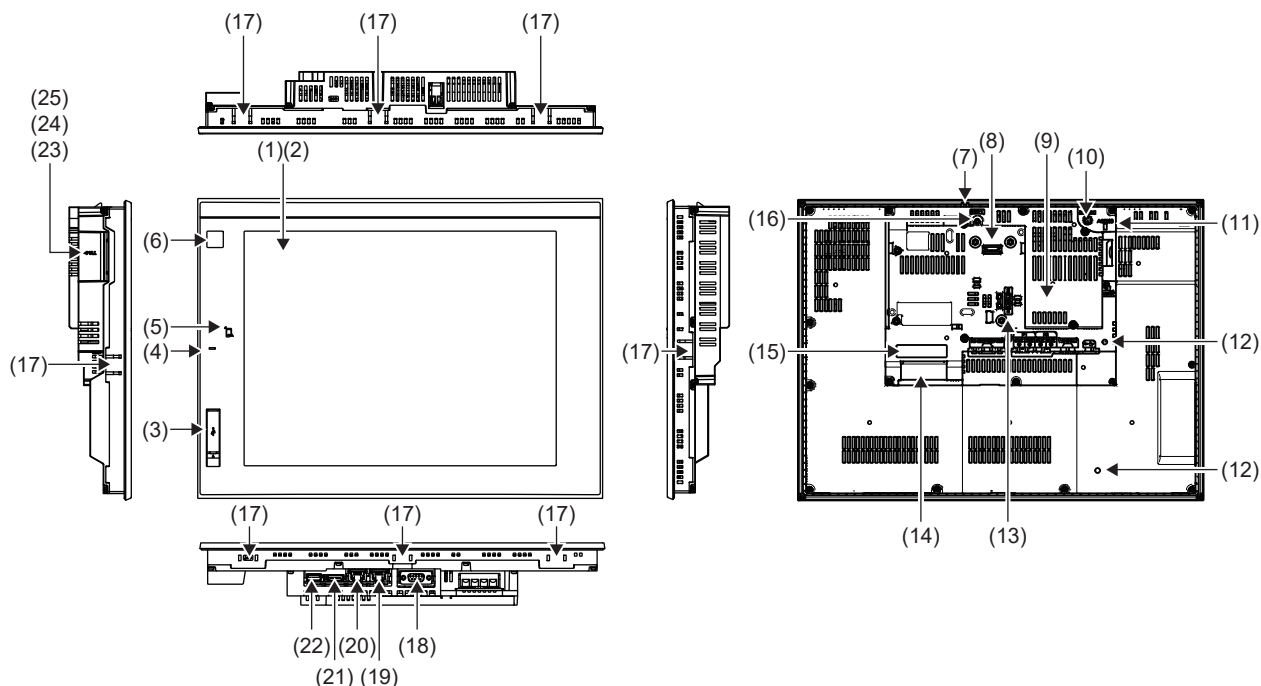

No.	Name	Description
(1)	Display section	For displaying the utility and user-created screens
(2)	Touch panel	For operating the touch switches in the utility and the user-created screen
(3)	Front USB interface (device/host)	For connecting a USB device or a personal computer (connector shape: USB Type-C)
(4)	Power LED	<ul style="list-style-type: none"> • Lit: Power is supplied. • Blinking (fade-in/fade-out): Screen saver is active. • Blinking: Backlight has failed. • Unlit: Power is not supplied.
(5)	Contactless tag	For contactless communication with mobile devices
(6)	Human sensor	Detects human movement. Applicable model:GT3715-X,GT3712-X
(7)	Temporary fixing hook	A hook to prevent the GOT from falling from the control panel when installed
(8)	Extension interface	For installing a communication unit or an option unit
(9)	Rating plate	⚠: Instructs the use of copper wire with an appropriate temperature rating (75°C or higher) for wiring and alerts users to exercise caution during battery replacement.*1
(10)	S.MODE switch	For installing the OS at GOT startup
(11)	SD card access LED	<ul style="list-style-type: none"> • Lit: SD card is inserted. • Blinking: SD card is being accessed. • Unlit: SD card is not inserted, or the inserted SD card is ready to be removed.
(12)	Cable clamp installation hole*2	For installing a cable clamp to prevent the video output cable or USB cable from being accidentally pulled out
(13)	Terminating resistor setting switch	For switching the terminating resistor for the RS-422/485 communication between 330 Ω, 100 Ω, and initial setting (unused).
(14)	Power supply terminal	Power input terminal, FG terminal, LG terminal
(15)	Power supply terminal indication	<ul style="list-style-type: none"> • ⚡ Electric shock warning (AC only): Warns of the risk of electric shock if exposed conductive parts are touched. • N~L (For AC input only): Indicates the position of the AC power input terminal. • ⎓ (For DC input only): Indicates the position of the DC power input terminal. The power supply varies depending on the input power type. Page 49 Specifications of the power supply section <ul style="list-style-type: none"> • ⏏ Functional grounding symbol: Indicates the functional ground terminal.
(16)	Reset switch	Hardware reset switch
(17)	Holes for the GOT installation fittings	Holes for installing the fittings used to secure the GOT to the panel

No.	Name	Description
(18)	RS-232/422/485 interface	For communications with a controller (connector shape: D-sub 9-pin (socket), M2.6 metric screw thread) For the connector pin layout, refer to the following.  GOT3000 Series User's Manual (Connection) When using RS-422/485 communication, set the terminating resistor with the terminating resistor setting switch.
(19)	Ethernet interface (port 1)	For communicating with a controller or connecting a personal computer (connector shape: RJ45 (modular jack))
(20)	Ethernet interface (port 2)	
(21)	Digital video output interface	For outputting a digital video
(22)	Rear face USB interface (host)	For connecting a USB device (connector shape: USB Type- A)
(23)	SD card cover	Provided with the switch function that allows or prohibits access to the SD card from the GOT. <ul style="list-style-type: none"> • When the SD card cover is open: Access is prohibited. • When the SD card cover is closed: Access is allowed.
(24)	SD card interface (inside the SD card cover)	For installing an SD card
(25)	Battery storage area (inside the SD card cover)	Space for housing the battery

*1 Leave the GOT on for more than 10 minutes before replacing the battery.

Replace the battery within five minutes.

 Page 82 Installing and removing the battery

Be sure to use the GT11-50BAT.

 Page 55 Battery

Replacing the battery with an incorrect one may cause an explosion.

Dispose of the used battery according to the instructions.

*2 The GT3715-X has two cable clamp installation holes.

Use one of the holes.

PART 5

Operating the GOT

10 Procedure before operation

10 Procedure before operation

This section explains the procedure before operating the GOT.

The procedure before operation differs depending on the security mode set for the project.

For the procedure before operation and the differences depending on the security mode, refer to the following.

 Page 64 Procedure before operating the GOT

What is the security mode?

The GOT's security function has two security modes.

Security mode	Description
Mode 1	The security functions compatible with the GOT2000 series can be used.
Mode 2 (default)	More robust security functions than mode 1 can be used.

Security mode settings can be configured only with GT Designer3.

For details, refer to the following.

 GT Designer3 (GOT3000) Screen Design Manual

10.1 Procedure before operating the GOT

This section explains the procedure before operating the GOT and the manuals describing the details.

The procedure before operation differs depending on the security mode.

The necessity of each step is shown below.

○: Required, △: Optional, —: Not required

Step		Security mode		Reference
		Mode 1	Mode 2	
1	Install GT Designer3 on the personal computer.	○	○	📖GT Works3 Version1 Installation Instructions
2	Create a project with GT Designer3.	○	○	📖GT Designer3 (GOT3000) Screen Design Manual
	Set the Ethernet interface of the GOT when connecting the GOT and the controller via Ethernet.	△	△	📖GT Designer3 (GOT3000) Screen Design Manual
	Configure the settings for connecting the controller to the GOT.	○	○	📖GOT3000 Series User's Manual (Connection)
3	Install the battery (sold separately) in the GOT.	△*1	○	📖Page 82 Installing and removing the battery
4	Install the extension unit and options on the GOT.	△	△	📖Page 75 Installing and removing the extension unit
5	Install the GOT on the control panel.	○	○	📖Page 72 Installing and removing the GOT
6	Provide wiring to the power supply section of the GOT.	○	○	📖Page 102 Precautions for wiring the power supply 📖Page 103 Wiring of external power supply 📖Page 104 Power supply wiring to the GOT 📖Page 105 Grounding 📖Page 110 Wiring inside and outside the control panel 📖Page 112 Attaching a surge suppressor to control equipment
7	Turn on the GOT. The GOT includes a preinstalled demo screen project at the time of factory shipment. After the GOT is started and the initial settings are configured, the demo screen is displayed.	○	○	—
8	Write the project created with GT Designer3 to the GOT.*2	○	○	📖GT Designer3 (GOT3000) Screen Design Manual
	Enter the password when the file protection function is enabled.	△	△	📖GT Designer3 (GOT3000) Screen Design Manual
	If the security mode set for the project is mode 2, register the information of the operator with administrator privileges in the GOT.	—	○	📖GT Designer3 (GOT3000) Screen Design Manual
9	Turn off the GOT and connect the GOT and the controller.	○	○	📖GOT3000 Series User's Manual (Connection)
10	Turn on the GOT and the controller to start monitoring. You can check whether the GOT is monitoring normally.	○	○	📖Page 64 How to check whether the GOT is operating correctly

*1 Install a battery to retain the clock data even when the GOT is powered off.

*2 When a project is written to the GOT, the demo screen project is overwritten.

How to check whether the GOT is operating correctly

The following methods can be used to check for any issues with the operation of the project written to the GOT or the communication status with the controller.

Check	Method
Check whether the GOT recognizes the controller.	This can be checked on the [Communication setting] screen of the utility. 📖GOT3000 Series User's Manual (Utility & Maintenance Functions)
Check if an error (system alarm) has occurred in the GOT, controller, or network.	When an error occurs in the GOT, controller, or network, the GOT outputs a system alarm (error code and error message). The system alarm can be checked on the [System alarm] of the utility. 📖GOT3000 Series User's Manual (Utility & Maintenance Functions)
Check that the settings enable the GOT to communicate with the controller correctly and that the connection cable is connected properly.	This can be checked on the [I/O check] of the utility. 📖GOT3000 Series User's Manual (Utility & Maintenance Functions)

PART 6 Installation and removal

11 Precautions for installing the GOT

12 Installation position

13 Control panel inside temperature and GOT installation angle

14 Installing and removing the GOT

15 Installing and removing the extension unit

16 Installing and removing the battery

17 Inserting and removing the SD card

18 Inserting and removing a USB device

19 Inserting and removing the USB cable

20 Installing and removing the panel-mounted USB port extension

21 Inserting and removing the HDMI cable

11 Precautions for installing the GOT

Install the GOT considering the control panel's internal dimensions and the prohibited installation area.

Depending on the types of connection cables connected to the GOT, the distance more than the described dimensions may be required.

Install the GOT with consideration of the connector dimensions and the cable bend radius.

12 Installation position

When installing the GOT, keep the GOT a certain distance from structures and other devices. This section describes the distance required for each GOT model.

☞ Page 67 GT37

12.1 GT37

☞ Page 68 GT3715-FH, GT3712-WX

☞ Page 69 GT3715-X, GT3712-X, GT3710-X, GT3708-X

☞ Page 70 Depth with an extension unit installed

Precautions

■ Installation position when connecting extension units and cables

Depending on the units and cables used for the GOT, more than the stated distance may be required.

Install the GOT taking into consideration the connector dimensions and the cable bend radius.

For the cable pull-out distance from the bottom of the GOT, refer to the following.

☞ Page 164 Cable bend radius for GT37 with an extension unit

■ Orientation for vertical installation

When installing the GOT vertically, ensure that the SD card cover faces down.

☞ Page 58 GT37

12.1.1

GT3715-FH, GT3712-WX

The following table lists the distance required between the GOT and the other devices.

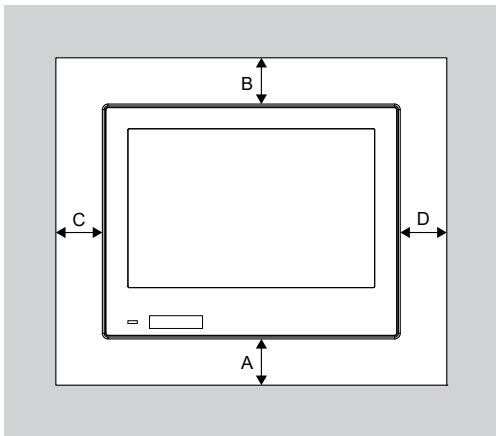

Horizontal

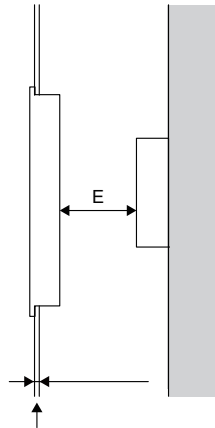

Panel thickness: 1.6 to 4 (0.06 to 0.16)

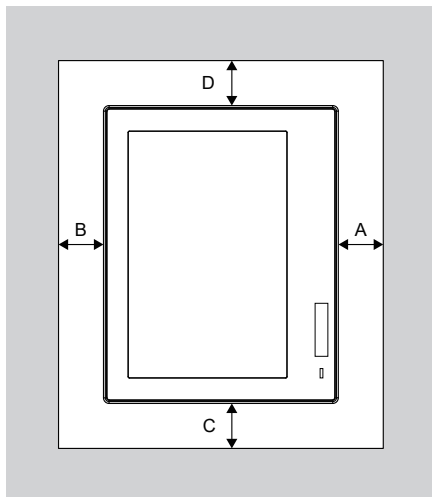

Vertical

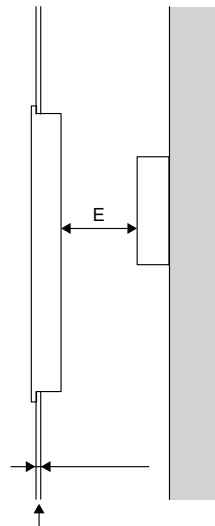

Panel thickness: 1.6 to 4 (0.06 to 0.16)

Unit: mm (in.)

Item		GT3715-FH	GT3712-WX
A		49 (1.93) or more	
B	Horizontal	79 (3.11) or more	
	Vertical	49 (1.93) or more	
C		50 (1.97) or more	
D	Horizontal	50 (1.97) or more	
	Vertical	80 (3.15) or more	
E		100 (3.94) or more	

12.1.2

GT3715-X, GT3712-X, GT3710-X, GT3708-X

The following table lists the distance required between the GOT and the other devices.

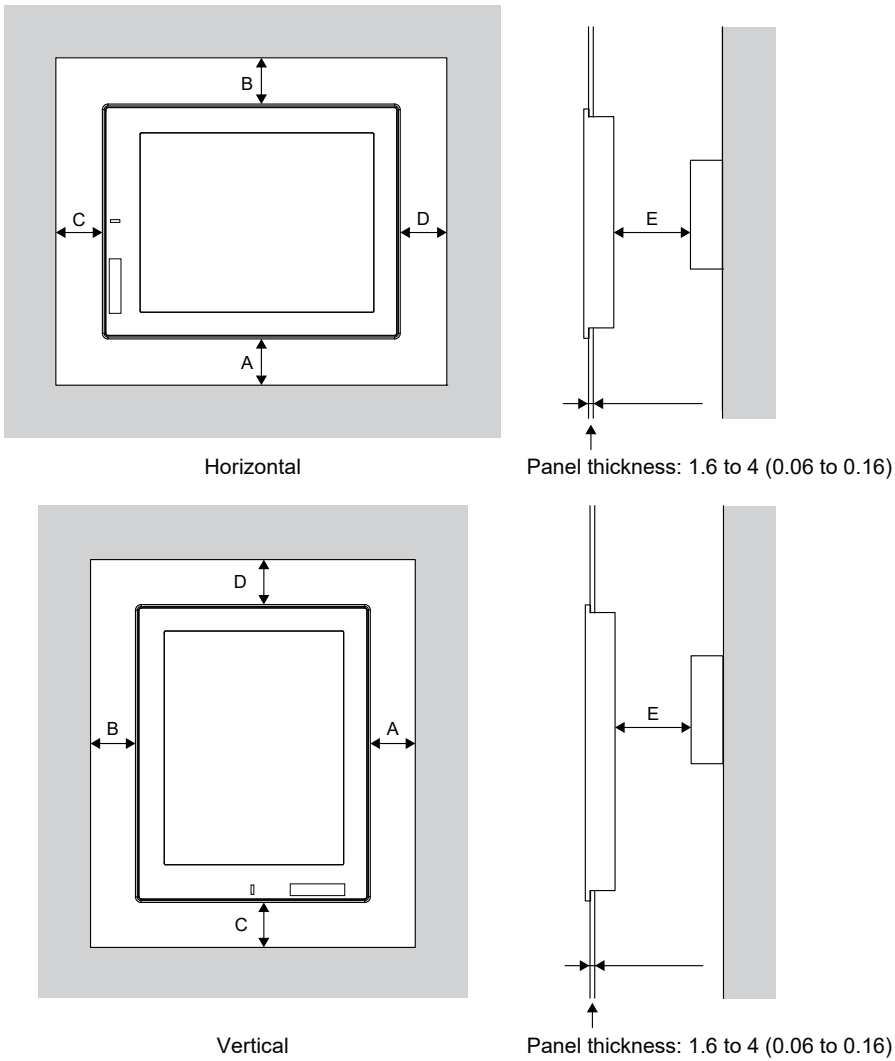

Unit: mm (in.)

Item		GT3715-X	GT3712-X	GT3710-X	GT3708-X
A		49 (1.93) or more			
B	Horizontal	79 (3.11) or more			
	Vertical	49 (1.93) or more			
C		50 (1.97) or more			
D	Horizontal	50 (1.97) or more			
	Vertical	80 (3.15) or more			
E		100 (3.94) or more			

12.1.3 Depth with an extension unit installed

This section describes the depth of the GOT with an extension unit installed.

To install an extension unit on the GOT, an extension interface converter unit (GT37-IF2000) is required.

Only one extension unit can be installed on the extension interface converter unit.

For the installation method of the extension unit and extension interface converter unit, refer to the following.

☞ Page 75 Installation

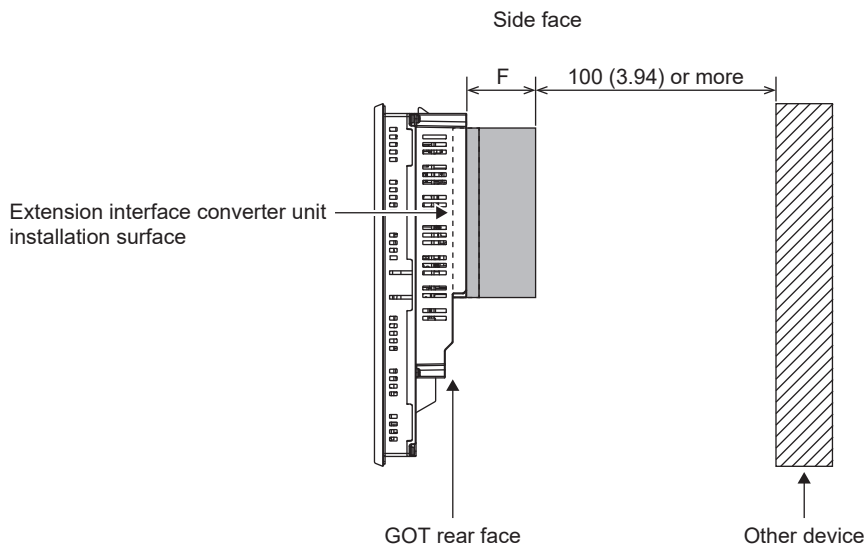

Unit: mm (in.)

Extension unit	F	
Serial communication unit	GT15-RS2-9P	30.5 (1.2)
	GT15-RS4-9S	30.5 (1.2)
	GT15-RS4-TE	30.5 (1.2)
CC-Link IE TSN communication unit	GT25-J71GN13-T2	28 (1.1)
CC-Link IE Controller Network communication unit	GT15-J71GP23-SX	44.5 (1.75)
CC-Link IE Field Network communication unit	GT15-J71GF13-T2	44.5 (1.75)
CC-Link communication unit	GT15-J61BT13	30.5 (1.2)
	GT15-QBUS	30.5 (1.2)
	GT15-QBUS2	30.5 (1.2)
	GT15-75QBUSL	17.5 (0.69)
MELSECNET/H communication unit	GT15-75QBUS2L	17.5 (0.69)
	GT15-J71LP23-25	30.5 (1.2)
External I/O unit	GT15-J71BR13	30.5 (1.2)
	GT15-DIO	30.5 (1.2)
	GT15-DIOR	30.5 (1.2)

13

Control panel inside temperature and GOT installation angle

Page 71 GT37

Install the GOT with its display section positioned as shown below.

13.1 GT37

Horizontal installation

- When the GOT is installed at any angle from 60° to 105° , the control panel inside temperature must be 55°C or lower.
- When the GOT is installed at any angle outside the above range, the control panel inside temperature must be 40°C or lower.

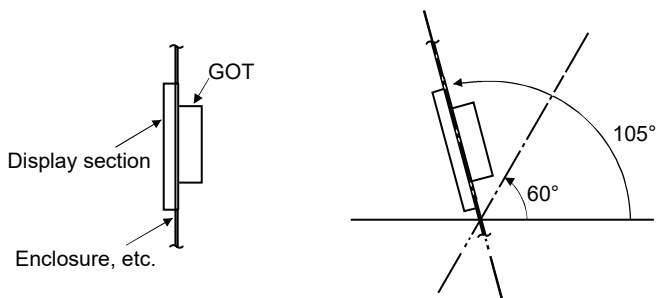

Point

Ensure that the control panel inside temperature does not exceed the above-mentioned temperatures. Otherwise, the product life may be shortened.

Vertical installation

- When the GOT is installed at a 90° angle, the control panel inside temperature must be 55°C or lower.
- When the GOT is installed at any angle outside the above range, the control panel inside temperature must be 40°C or lower.

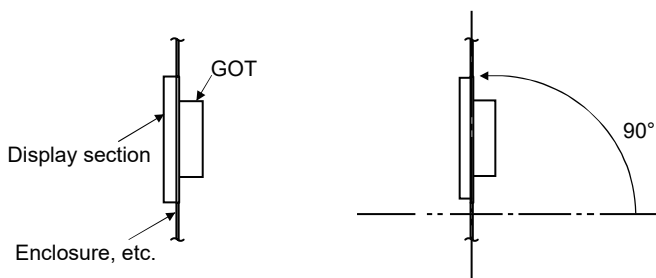

Point

Ensure that the control panel inside temperature does not exceed the above-mentioned temperatures. Otherwise, the product life may be shortened.

14 Installing and removing the GOT

This section describes the procedure for installing and removing the GOT.

☞ Page 72 Installing the GOT

☞ Page 74 Removing the GOT

For the panel cut dimensions for the GOT, refer to the following.

☞ Page 54 Panel cutting dimensions

14.1 Installing the GOT

The following shows the procedure for installing the GOT.

In this section, horizontal installation is described as an example.

When installing the GOT vertically, ensure that the SD card cover faces down.

☞ Page 58 GT37

1. Insert the GOT rear face into the panel opening.

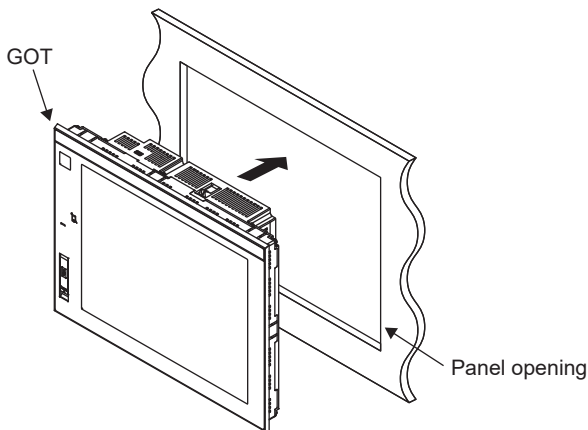

2. Attach the eight fittings to the installation holes on the GOT, and tighten the screws within the specified torque range (0.36 N·m to 0.48 N·m).

Tightening the screw with a torque exceeding the specified torque range may deform the GOT front panel, causing the protective sheet to become crinkled.

When installing the GT3715-FH, use the holes for the GOT installation fittings as shown in the following section.

☞ Page 58 GT3715-FH, GT3712-WX

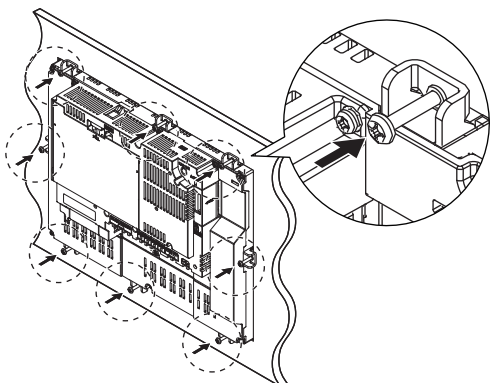

3. Remove the protective film from the GOT.

Precautions

■ Tightening torque of the mounting screws

Tighten the screws within the specified torque range (0.36 N·m to 0.48 N·m).

Undertightening can cause the GOT to drop.

In addition, waterproof effect or oilproof effect may not be obtained.

Tightening the screw in the specified torque range or more may damage the GOT or distort the panel, causing wrinkles on the surface of the display section. The wrinkles may lower visibility and lead to an incorrect input to the touch panel.

Waterproof effect or oilproof effect may not be obtained because of distortion of the GOT or panel.

■ Tightening method for mounting screws

Tighten each of the installation screws gradually and evenly.

Concentration of excessive force on a single GOT installation fitting may damage the GOT or distort the panel.

Tighten the mounting screws at right angles to the surface of the panel. (Refer to Figure (1).)

If mounting screws are not at right angles to the surface of the panel, excessive force will be applied and may damage the GOT. (Refer to Figure (2).)

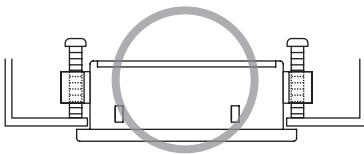

(1) Good

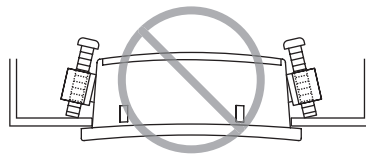

(2) Bad

14.2 Removing the GOT

The following shows the procedure for removing the GOT.

1. Remove the mounting screws from the GOT installation fittings and remove the fittings.

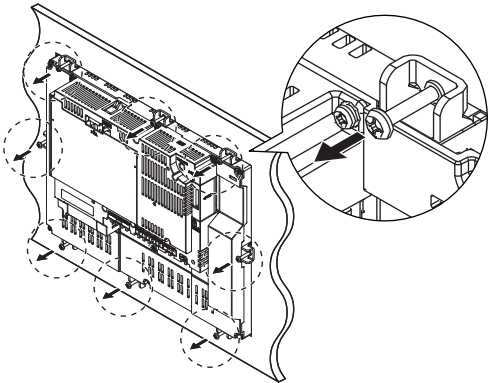

2. Press down the temporary fixing tab on the top of the GOT and remove the GOT from the panel opening.

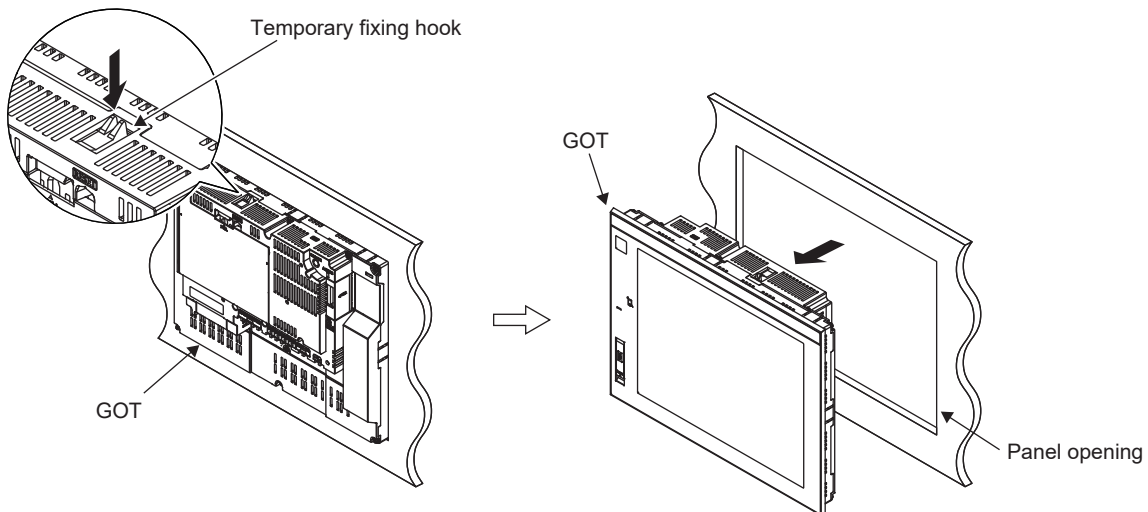

15 Installing and removing the extension unit

This section describes the procedure for installing an extension unit on the GOT and removing the unit from the GOT.

☞ Page 75 Installation

☞ Page 80 Removal

15.1 Installation

The following shows the procedure for installing an extension unit on the GOT.

To install an extension unit on the GOT, install the extension interface converter unit (GT37-IF2000) on the GOT in advance.

For the procedure for installing the extension interface converter unit, refer to the following.

☞ Page 76 Installing the extension interface converter unit

Only one extension unit can be installed on the extension interface converter unit.

For the procedure for installing an extension unit on the extension interface converter unit, refer to the following.

☞ Page 77 Installing an extension unit

15.1.1 Installing the extension interface converter unit

1. Make sure that the GOT power is off.
2. Remove the extension unit cover from the GOT.

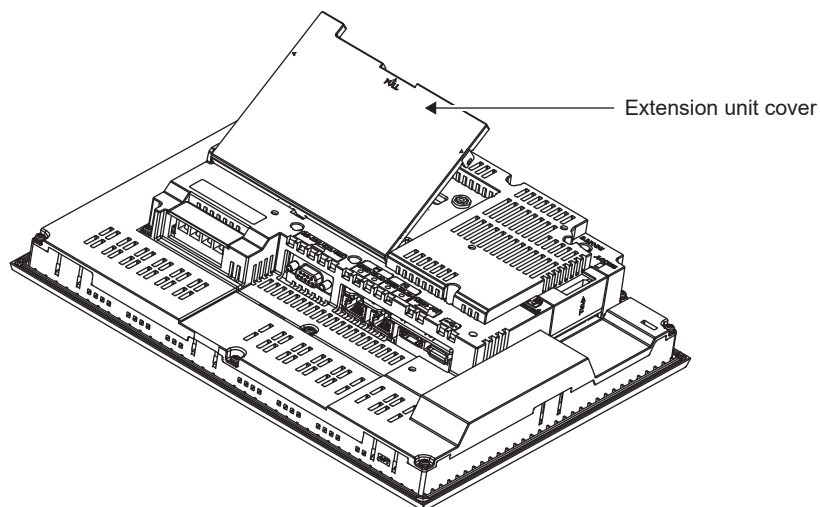

3. Install the extension interface converter unit on the GOT.
Tighten the five mounting screws of the extension interface converter unit within the specified torque range (0.36 N·m to 0.48 N·m).

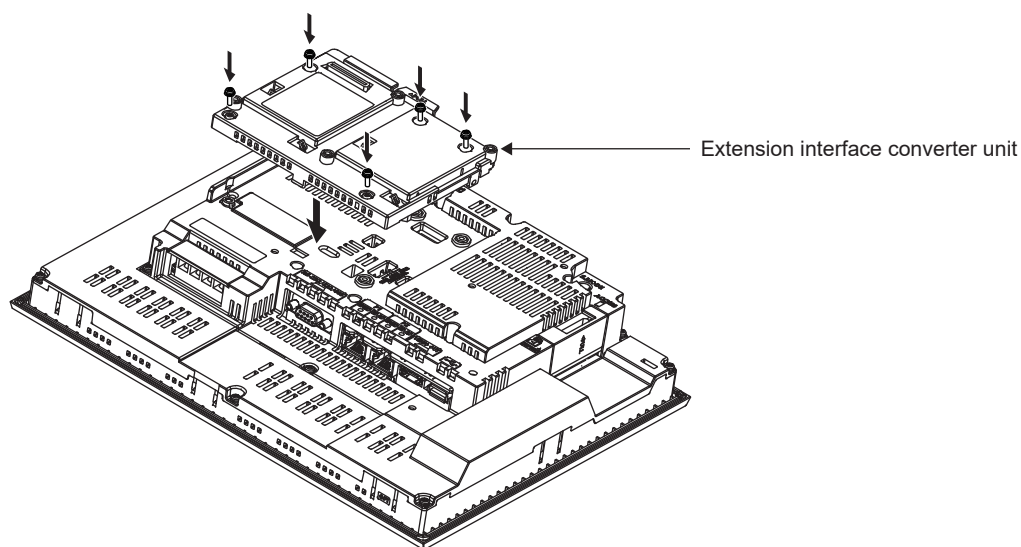

15.1.2 Installing an extension unit

Installing the extension unit for one channel

1. Fit the extension unit in the extension interface converter unit case.
2. Tighten the two mounting screws of the extension unit within the specified torque range (0.36 N·m to 0.48 N·m) to fix the unit.

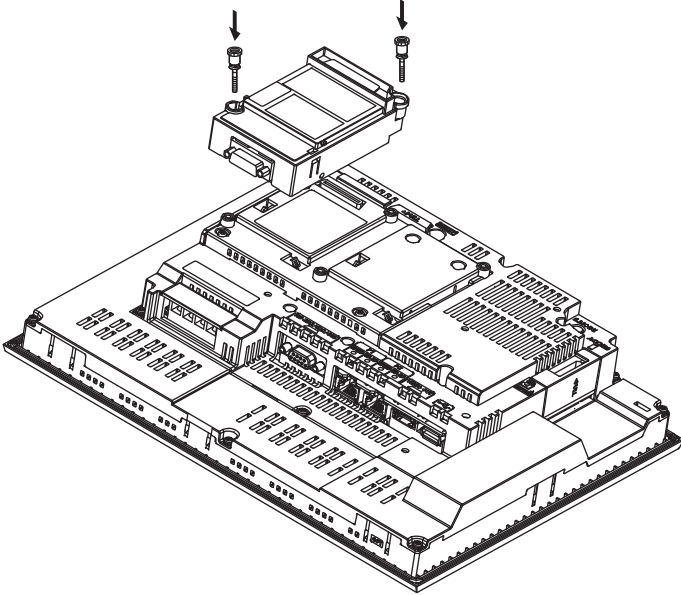

3. To prevent the entry of static electricity, attach the supplied insulation cover to the extension interface converter unit.

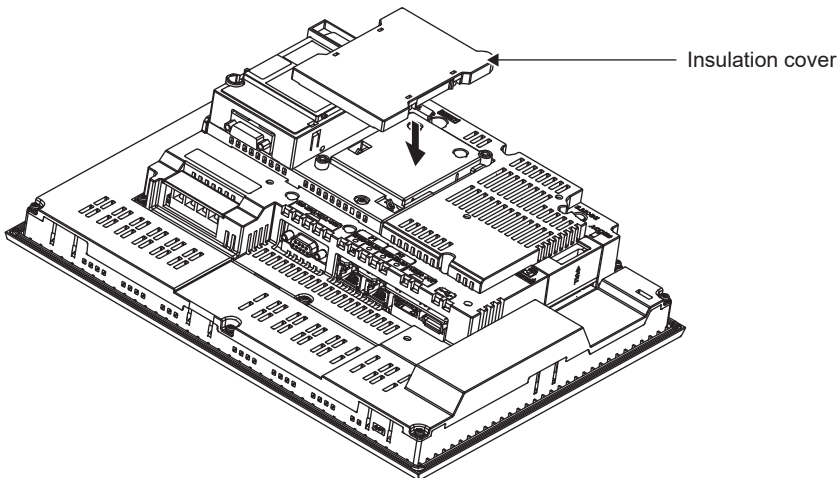

- 4.** Cover the mounting screws with the stickers supplied with the extension unit.
Leave the connector cover and the stickers attached.

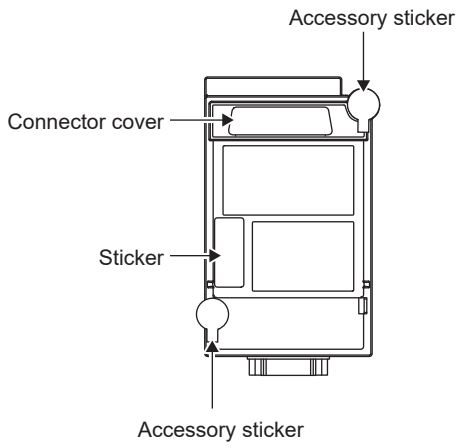

Installing the extension unit for two channels

1. Fit the extension unit in the extension interface converter unit case.
2. Tighten the four mounting screws of the extension unit within the specified torque range (0.36 N·m to 0.48 N·m) to fix the unit.

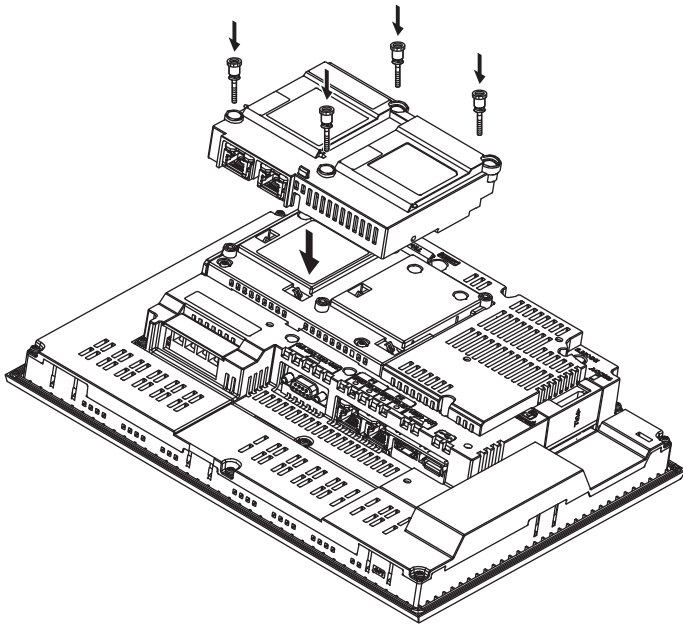

3. To prevent the entry of static electricity, cover the mounting screws with the stickers supplied with the extension unit. Leave the stickers attached.

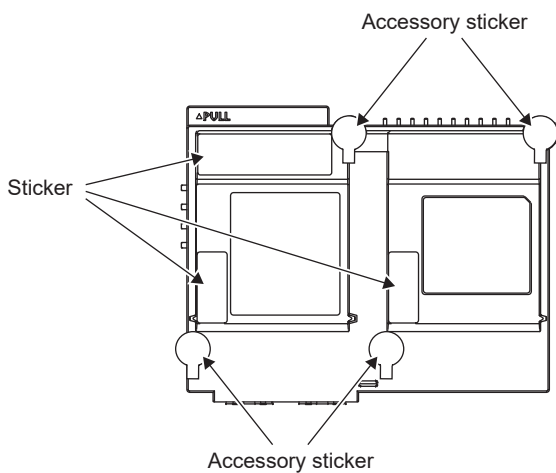

15.2 Removal

The following shows the procedure for removing the extension unit from the GOT.

1. Make sure that the GOT power is off.
2. Remove the stickers from the extension unit.
3. Remove the mounting screws from the extension unit.

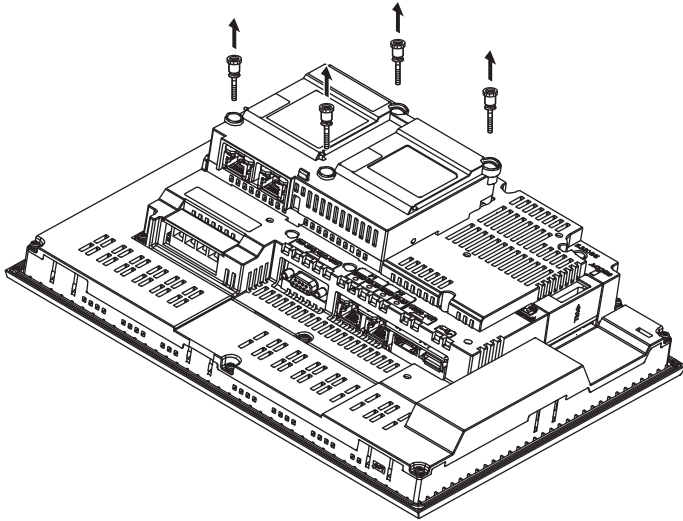

4. Remove the extension unit.

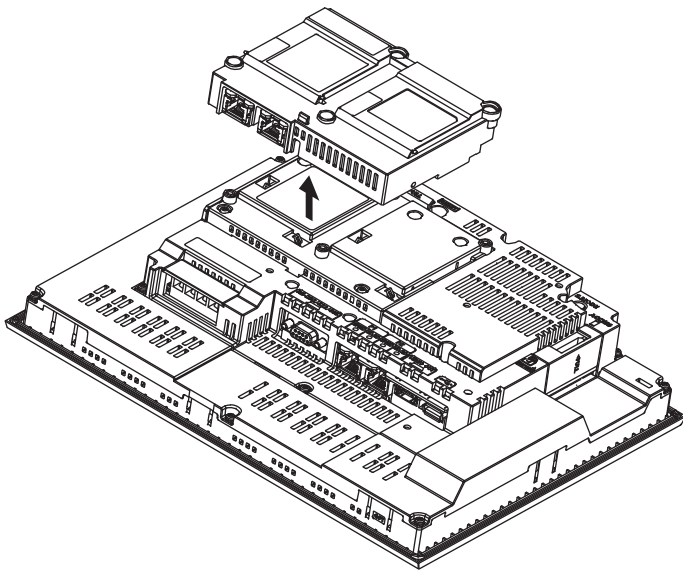

5. Remove the mounting screws from the extension interface converter unit.

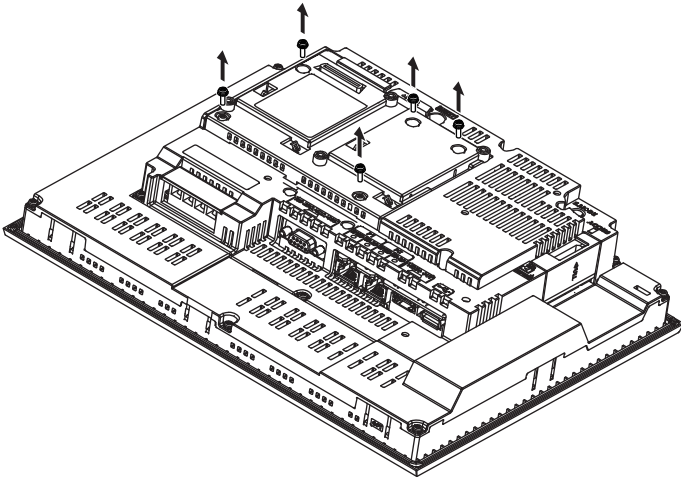

6. Remove the extension interface converter unit.

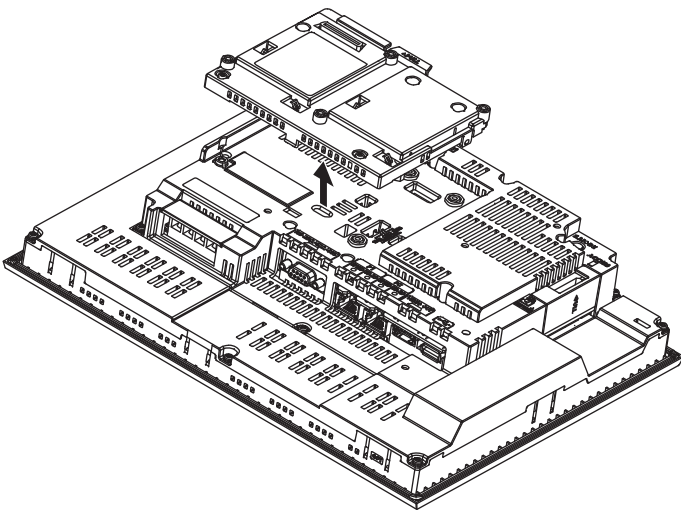

7. Attach the extension unit cover of the GOT.

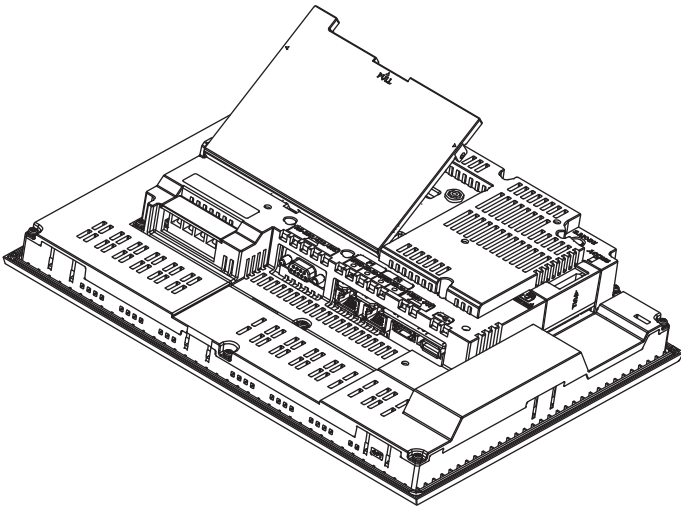

16 Installing and removing the battery

This section describes the procedure for installing and removing the battery from the GOT.
(Described with the GOT rear face facing up.)

☞ Page 82 Installing the battery

☞ Page 84 Removing the battery

Point

To back up the clock data, a battery (sold separately) must be installed in the GOT.

Precautions

To replace the battery, leave the GOT on for 10 minutes or more before replacing the battery.
Replace the battery within 5 minutes.

16.1 Installing the battery

The following shows the procedure for installing the battery in the GOT.

1. Make sure that the GOT power is off.
2. Install the battery inside the SD card cover on the side of the GOT.
Open the SD card cover as shown below.

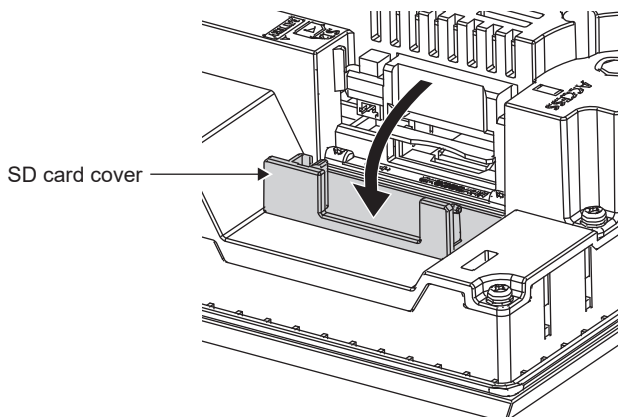

3. To replace the battery, remove the old battery from the battery holder, and then remove the battery connector from the GOT connector.

For information on the procedure to remove the battery, refer to the following.

☞ Page 84 Removing the battery

4. Insert the battery connector to the GOT connector.

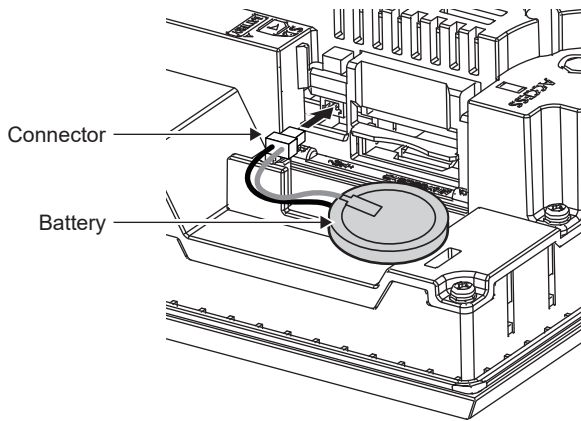

5. After installing the battery to the battery holder of the GOT, close the SD card cover until it clicks.

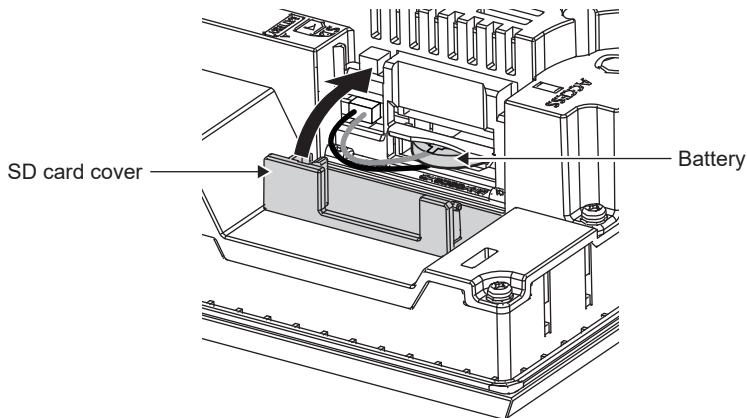

6. Power on the GOT.
7. Check that the battery voltage status is normal with the utility function of the GOT.
For the battery voltage status, refer to the following.
 GOT3000 Series User's Manual (Utility & Maintenance Functions)

16.2 Removing the battery

The following shows the procedure for removing the battery from the GOT.

1. Make sure that the GOT power is off.
2. The battery is stored inside the SD card cover on the side of the GOT.
Open the SD card cover as shown below.

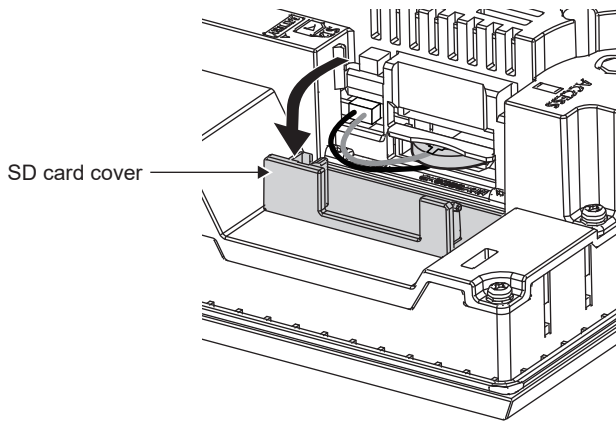

3. After removing the battery from the battery holder of the GOT, unplug the battery connector from the GOT connector.

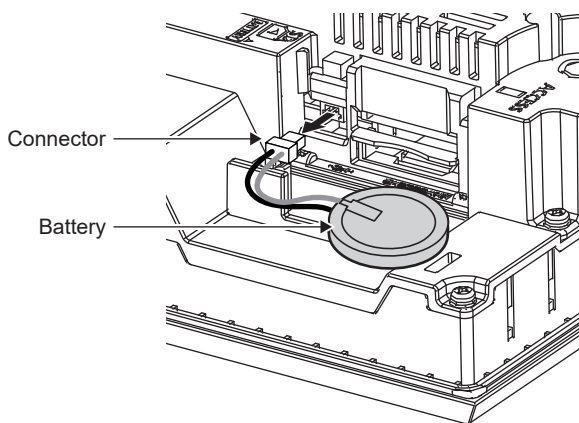

4. Close the SD card cover until it clicks.

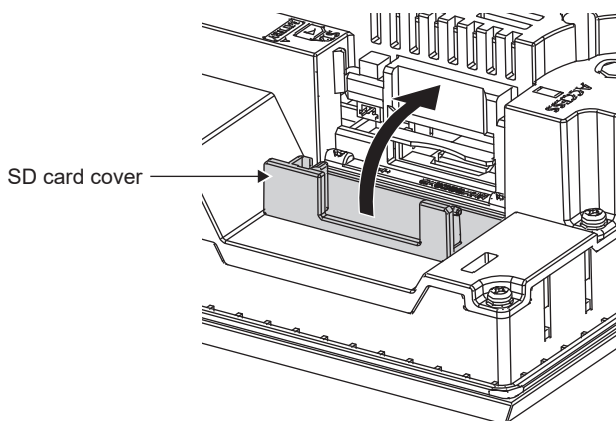

17

Inserting and removing the SD card

This section describes the procedure for inserting and removing the SD card from the GOT.

☞ Page 86 Inserting the SD card

☞ Page 87 Removing the SD Card

WARNING

- If the SD card in drive A of the GOT is removed while the GOT is accessing it, the GOT may stop processing for about 20 seconds.
During this stop, you cannot operate the GOT, and the functions running in the background, including the screen refresh, alarm, logging, and script, also stop.
This stop may affect the system operation, causing an accident.
Before removing the SD card, check that the SD card access LED is off.

CAUTION

- If you remove the data storage from the GOT while the GOT is accessing it, the data storage or files may get damaged.
Before removing the data storage, check the SD card access LED, relevant system signal, or others to make sure that the data storage is not being accessed. If the data storage is damaged, the GOT may not function properly.
- Turning off the GOT while it accesses the SD card results in damage to the SD card and files.
- After inserting an SD card into the GOT, make sure to close the SD card cover.
Not doing so may prevent the data from being read or written.
- To remove the data storage from the GOT, follow the procedure for removal on the utility screen of the GOT.
After the successful completion dialog appears, remove the data storage while holding it carefully.
Not doing so may cause the data storage to drop, resulting in damage or failure.

17.1 Inserting the SD card

The following shows the procedure for inserting the SD card into the GOT.

1. Open the SD card cover as shown below.

(Described with the GOT rear face facing up.)

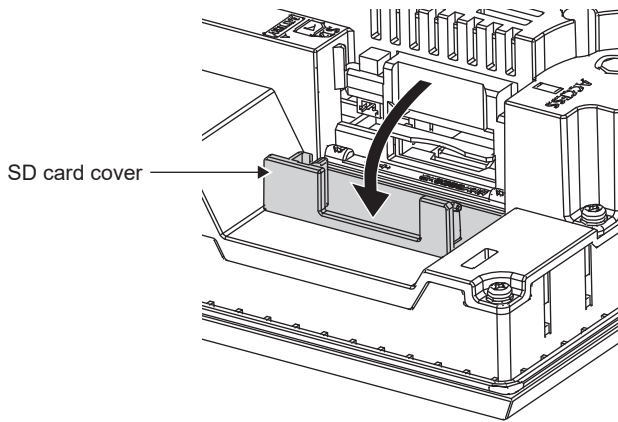

2. Open the SD card cover 90 degrees and check that the SD card access LED is off. Then insert the SD card face up into the SD card interface.

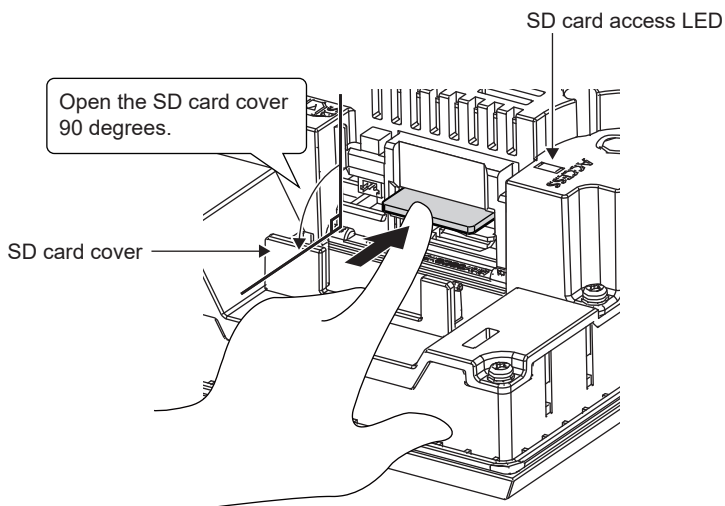

3. Close the SD card cover until it clicks.

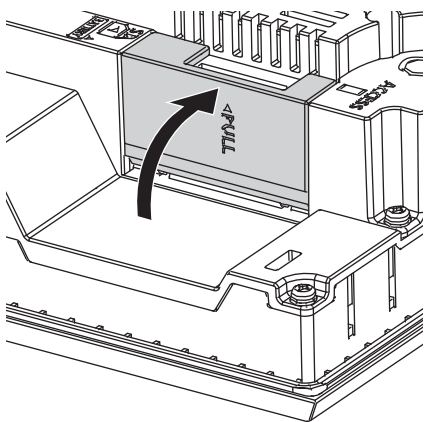

4. When the SD card cover is closed, the SD card can be accessed.

17.2 Removing the SD Card

The following shows the procedure for removing the SD card from the GOT.

1. Open the SD card cover as shown below.

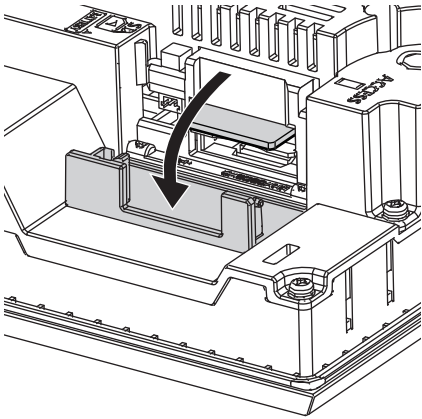

2. Open the SD card cover 90 degrees and check that the SD card access LED is off. Then push the SD card in to eject it.

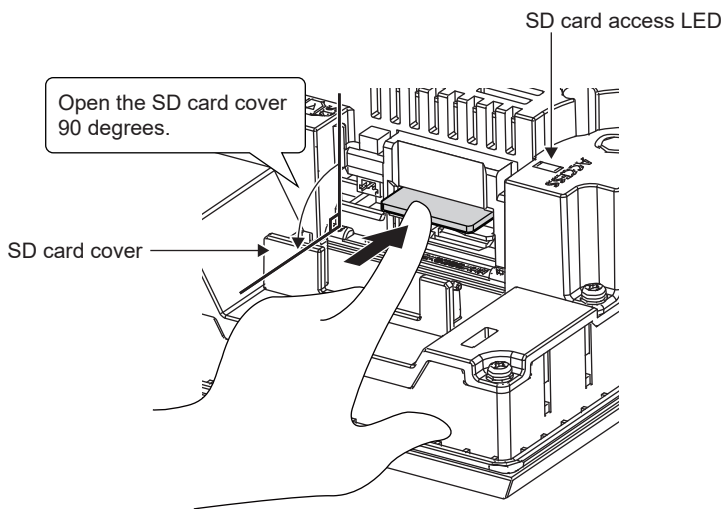

3. Close the SD card cover until it clicks.

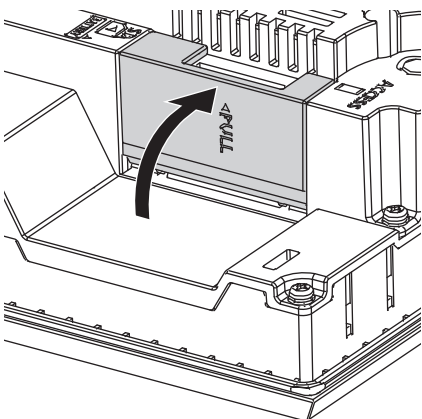

18 Inserting and removing a USB device

This section describes the procedure for inserting and removing a USB device from the GOT.

☞ Page 88 Inserting a USB device

☞ Page 90 Removing the USB device

Precautions

When connecting a USB device to the USB interface (host) using a USB hub with the GOT power on, drive assignment of the connected USB devices may be changed.

If you do not want the drive assignment to change, connect the USB device before powering on the GOT.

18.1 Inserting a USB device

The following shows the procedure for inserting a USB device into the GOT.

Inserting a USB device into the front USB interface (device/host)

1. Push the \triangle mark on the USB environmental protection cover to open the cover.

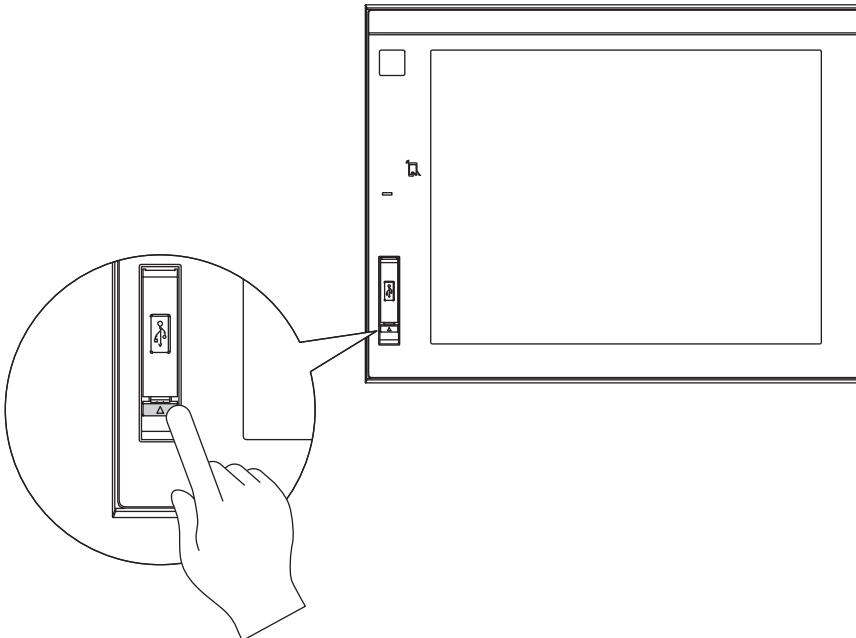

2. Insert the USB device into the USB interface (device/host) as shown below.

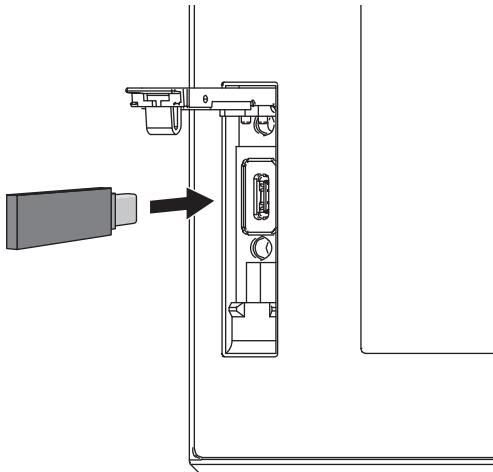

Inserting a USB device into the rear USB interface (host)

1. Insert the USB device into the USB interface (host) as shown below. Make sure to insert the USB interface connector in the correct direction.

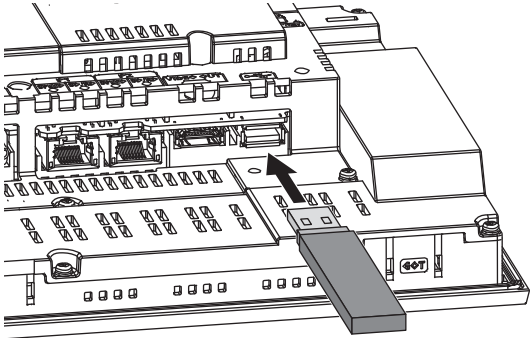

18.2 Removing the USB device

The following shows the procedure for removing the USB device from the GOT.

Removing the USB device from the front USB interface (device/host)

1. Ensure the GOT is in "safely remove hardware" mode.

For the setting method, refer to the following.

📖 GOT3000 Series User's Manual (Utility & Maintenance Functions)

2. Remove the USB device from the USB interface (device/host) as shown below.

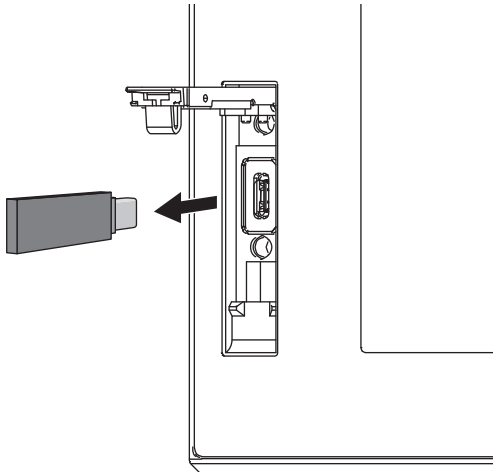

3. Push the \triangle mark on the USB environmental protection cover to close the cover.

Removing the USB device from the rear USB interface (host)

1. Ensure the GOT is in "safely remove hardware" mode.

For the setting method, refer to the following.

📖 GOT3000 Series User's Manual (Utility & Maintenance Functions)

2. Remove the USB device from the USB interface (host) as shown below.

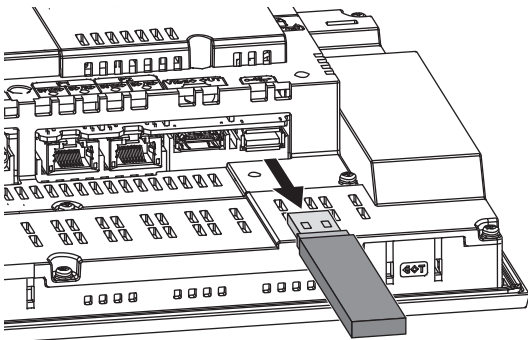

19 Inserting and removing the USB cable

This section describes the procedure for inserting and removing the USB cable from the rear USB interface.

☞ Page 91 Inserting the USB cable

☞ Page 93 Removing the USB cable

Install a cable clamp depending on the usage environment, such as when it is difficult to keep the cable in place.

Use the following cable clamp or an equivalent.

Manufacturer	Model
KITAGAWA INDUSTRIES CO., LTD.	RSG-130-V0

19.1 Inserting the USB cable

The following shows the procedure for inserting the USB cable and fixing the cable clamp to the GOT.

1. Insert the USB cable into the rear USB interface (host).

Make sure to insert the USB cable connector in the correct direction.

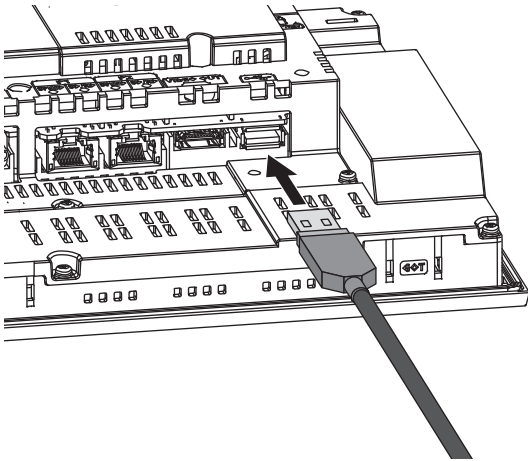

2. Insert a cable clamp into the cable clamp installation hole shown in the figure below, and push the clamp in until it clicks. For the direction to thread the band, refer to the arrow in the figure.

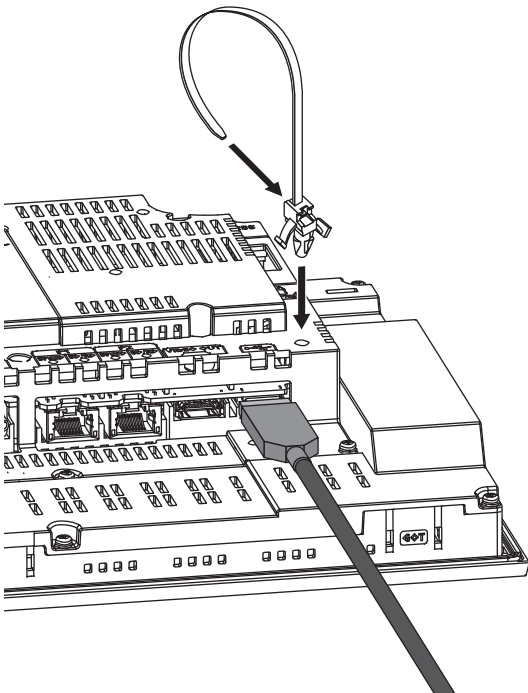

3. Pass the USB cable through the hole on the cable clamp and pull the band to fix the cable in place.

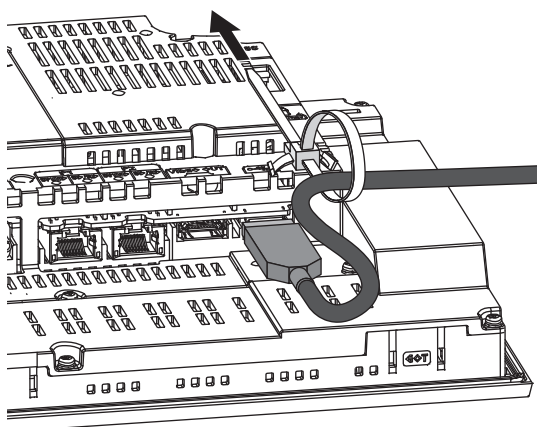

Point 

Use a cable clamp depending on the usage environment, such as when it is difficult to keep the USB cable in place.

The GT3715-X has two cable clamp installation holes.

When installing the cable clamp, use either hole.

19.2 Removing the USB cable

The following shows the procedure for removing the USB cable and the cable clamp from the GOT.

1. Remove the cable clamp band.

Pull out the band while pushing up the tab on the cable clamp with a screwdriver or another tool.

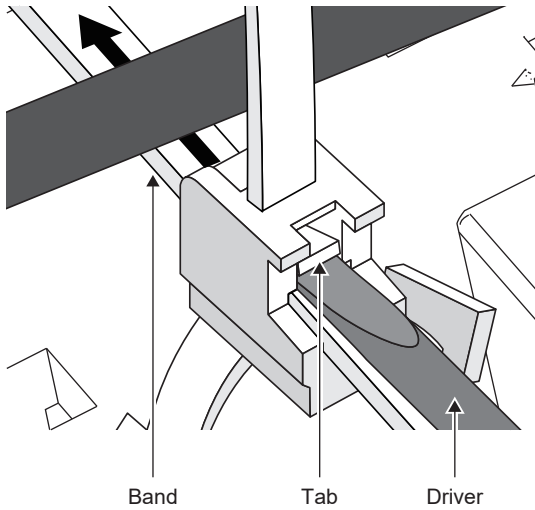

2. Remove the cable clamp while holding it from both sides (arrows A).

Removing the USB cable.

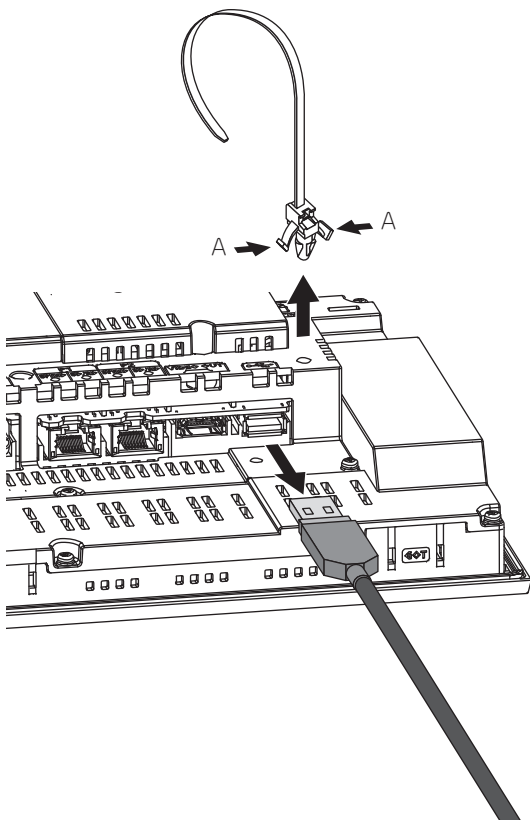

Even with the cable clamp installed, the USB cable can be removed from the unit.
Remove the cable clamp while holding it from both sides (arrows A).

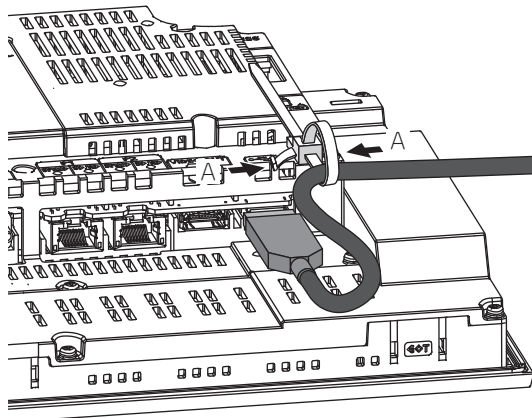

20

Installing and removing the panel-mounted USB port extension

The panel-mounted USB port extension is a waterproof USB extension cable.

The cable is used to route the USB interface (host) on the rear of the GOT to the control panel.

☞ Page 95 Part names of the panel-mounted USB port extension

☞ Page 96 Installing and removing the panel-mounted USB port extension

20.1

Part names of the panel-mounted USB port extension

The following shows the part names of the panel-mounted USB port extension (GT14-C10EXUSB-4S).

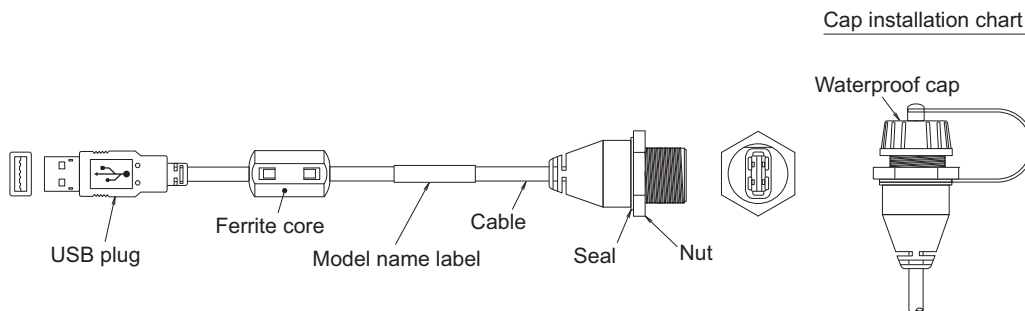

20.2 Installing and removing the panel-mounted USB port extension

Install or remove the panel-mounted USB port extension as follows making sure not to bend or distort the waterproof cap, seal, or nut.

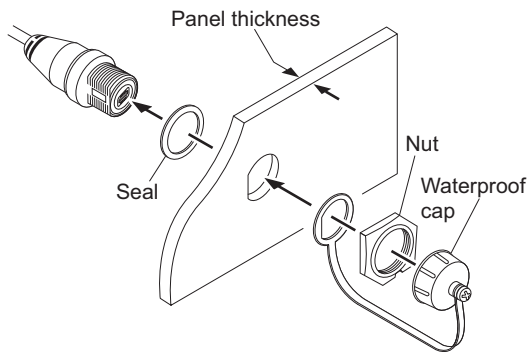

Panel Cutting Dimensions

GT14-C10EXUSB-4S

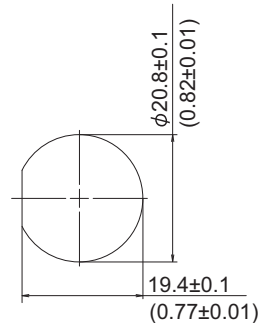

Panel thickness:
2 to 4 (0.08 to 0.16inch)
Specified torque range:
0.30N·m to 0.34N·m

Unit: mm (inch)

Precautions

■Precautions for installation and removal

Install the waterproof cap to the panel-mounted USB port extension so that the control panel surface is IP67F-rated. Overtightening or undertightening may disable the waterproof effect. Tighten the waterproof cap properly when the cable is not used.

■Precautions for installation

Run power lines, servo amplifier drive wires, and panel-mounted USB port extensions so that they do not cross each other. Install the panel-mounted USB port extension away from noise sources such as equipment. Do not twist, bend at a sharp angle or a right angle, and stretch the panel-mounted USB port extension since the cable may be broken.

- Dimension of the protruding cable

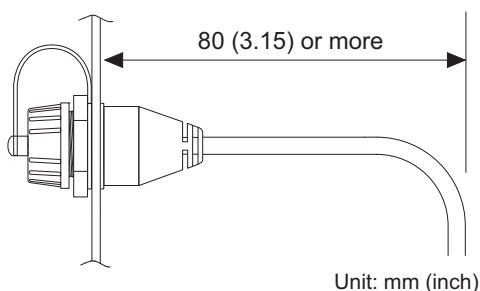

Unit: mm (inch)

Insert the USB plug part of the tip of the panel-mounted USB interface (host) extension securely to the USB port of the GOT. The USB plug part may work loose or become unplugged due to vibrations, impacts, or being yanked.

Secure the cable to the structure inside the control panel or to the cable clamp installation hole on the GOT using a cable clamp or other methods.

When bending the panel-mounted USB port extension for wiring, ensure that the bending points are at least 80 mm away from both ends of the USB connector.

21 Inserting and removing the HDMI cable

This section describes the procedure for inserting and removing the HDMI cable from the digital video output interface on the rear of the GOT.

☞ Page 97 Installing the HDMI cable

☞ Page 99 Removing the HDMI cable

Install a cable clamp depending on the usage environment, such as when it is difficult to keep the cable in place.

Use the following cable clamp or an equivalent.

Manufacturer	Model
KITAGAWA INDUSTRIES CO., LTD.	RSG-130-V0

21.1 Installing the HDMI cable

The following shows the procedure for inserting the HDMI cable and fixing the cable clamp to the GOT.

1. Connect the HDMI cable to the digital video output interface on the GOT rear face.

Ensure the HDMI cable is inserted correctly.

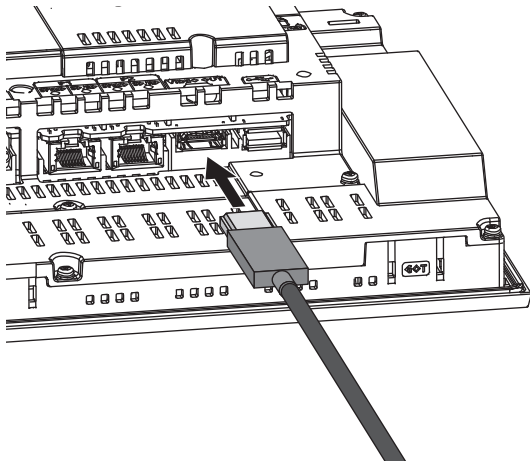

2. Insert a cable clamp into the cable clamp installation hole shown in the figure below, and push the clamp in until it clicks. For the direction to thread the band, refer to the arrow in the figure.

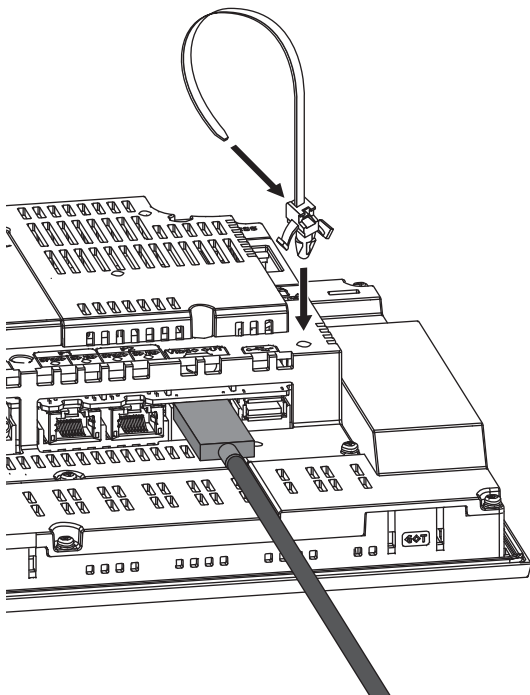

3. Pass the HDMI cable through the hole on the cable clamp and pull the band to fix the cable in place.

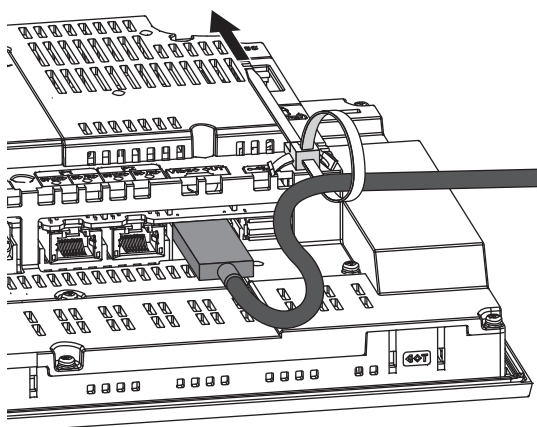

Point 

Use a cable clamp depending on the usage environment, such as when it is difficult to keep the HDMI cable in place.

The GT3715-X has two cable clamp installation holes.

When installing the cable clamp, use either hole.

21.2 Removing the HDMI cable

The following shows the procedure for removing the HDMI cable and the cable clamp from the GOT.

1. Remove the cable clamp band.

Pull out the band while pushing up the tab on the cable clamp with a screwdriver or another tool.

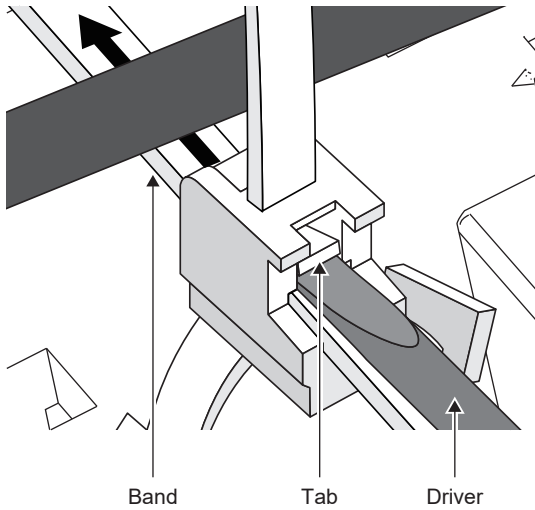

2. Remove the cable clamp while holding it from both sides (arrows A).

Remove the HDMI cable.

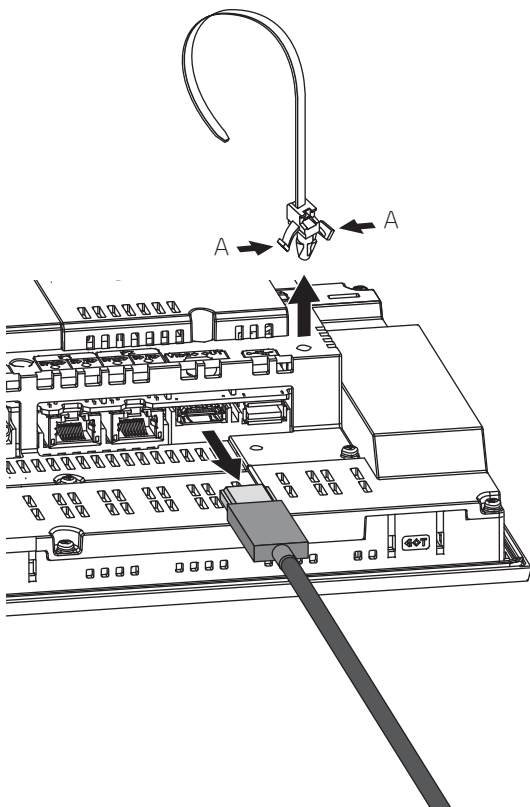

Even with the cable clamp installed, the HDMI cable can be removed from the unit.
Remove the cable clamp while holding it from both sides (arrows A).

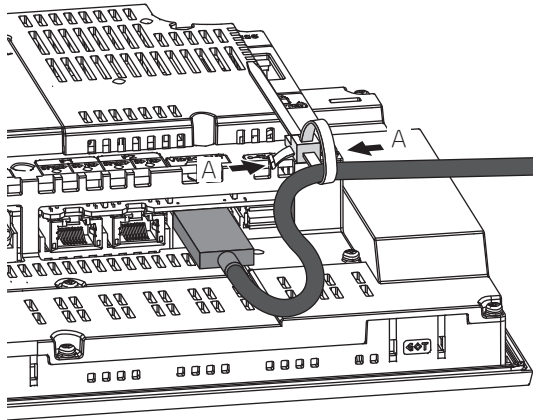

PART 7

Wiring of power supply section

22 Precautions for wiring the power supply

23 Wiring of external power supply

24 Power supply wiring to the GOT

25 Grounding

26 Wiring inside and outside the control panel

27 Attaching a surge suppressor to control equipment

22

Precautions for wiring the power supply

WARNING

- Before wiring, make sure to shut off all phases of the external power supply used by the system. Not doing so may result in an electric shock, product damage or malfunction.

CAUTION

- Make sure to ground the FG terminal and LG terminal of the GOT power supply section using a grounding wire dedicated to the GOT. (Ground resistance: 100 Ω or less, ground cable diameter: 1.6 mm or more)
Not doing so may result in an electric shock or malfunction.
- When wiring the GOT power section, tighten the terminal screws using a Phillips-head screwdriver No. 2 within the specified torque range below.
 - Specified torque range: (0.5 N•m to 0.8 N•m)
- Use an applicable solderless terminal for terminal processing of a wire to the GOT power supply section and tighten them with the specified torque. Using a solderless spade terminal can cause it to fall off and lead to a malfunction if the terminal screws become loose.
- Correctly wire the GOT power supply section after confirming the rated voltage and terminal layout of the product. Not doing so can cause a fire or malfunction.

This section describes the wiring to the GOT power supply section.

For connection to a controller, refer to the following.

 GOT3000 Series User's Manual (Connection)

For external dimensions of connection cable, refer to the following.

 Page 56 Communication cable

General preventive measures against noise

There are two kinds of noise: Radiated noise that is transmitted into the air and conductive noise that is directly transmitted along connected lines.

Countermeasures must be taken considering both kinds of noise and referring to the following 3 points.

Countermeasure	Concrete example
Protecting against noise	<ul style="list-style-type: none">• Keep signal lines away from noise sources such as power lines or high-power drive circuits.• Shield the signal lines.
Reducing generated noise	<ul style="list-style-type: none">• Reduce the noise generated from high-power motor drive circuits, etc. using noise filters or similar devices.• Install surge suppressors on the terminal sections of wiring circuit breakers, electromagnetic contactors, relays, solenoid valves, induction generators, etc. to suppress noise.
Releasing noise to the ground	<ul style="list-style-type: none">• Make sure to connect the ground cable to the ground.• Use a short and thick ground cable to lower the ground resistance of the cable.• Ground the power system and the control system separately.

23

Wiring of external power supply

- Page 103 Separating the power supply system
- Page 103 Separating the power cables from the main circuit cables and the I/O signal cables
- Page 103 Treatment of the power cables
- Page 103 Connecting the lightning surge absorber

23.1 Separating the power supply system

Wire the GOT power supply so that it is separate from the I/O equipment and power equipment as shown below. When frequent noise is identified, connect an isolation transformer.

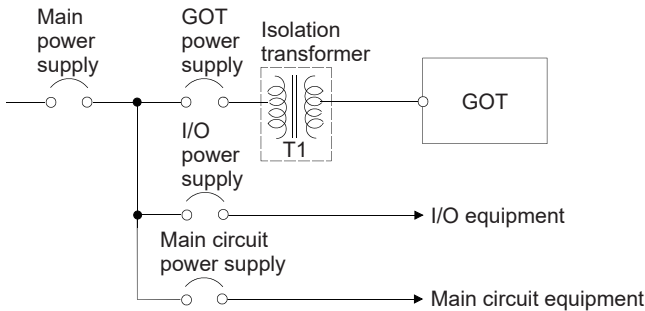

23.2 Separating the power cables from the main circuit cables and the I/O signal cables

Separate the main circuit cables (high voltage/large current) and I/O signal cables from the power cables (AC and DC power cables).

Keep a distance of 100 mm or more between them as a guide.

23.3 Treatment of the power cables

Twist the power cables (AC and DC power cables) as tightly as possible and use the shortest length of cable to connect the power supply to each device.

To minimize voltage drop, use a thick wire (cable cross section: approximately 0.75 mm² to 2 mm²).

Use the solderless terminal for M3, and tighten the terminal firmly with a torque of 0.5 N·m to 0.8 N·m.

23.4 Connecting the lightning surge absorber

For surge protection against lightning, connect a lightning surge absorber as shown below.

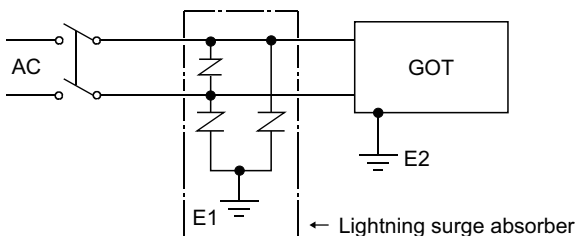

Separate the grounding of the lightning surge absorber (E1) from the grounding of the GOT (E2).

Select an appropriate lightning surge absorber that has the maximum allowable circuit voltage withstanding the maximum power supply voltage.

24

Power supply wiring to the GOT

The following shows an example of wiring the power cable, ground cable and other cables to the GOT power supply terminals.

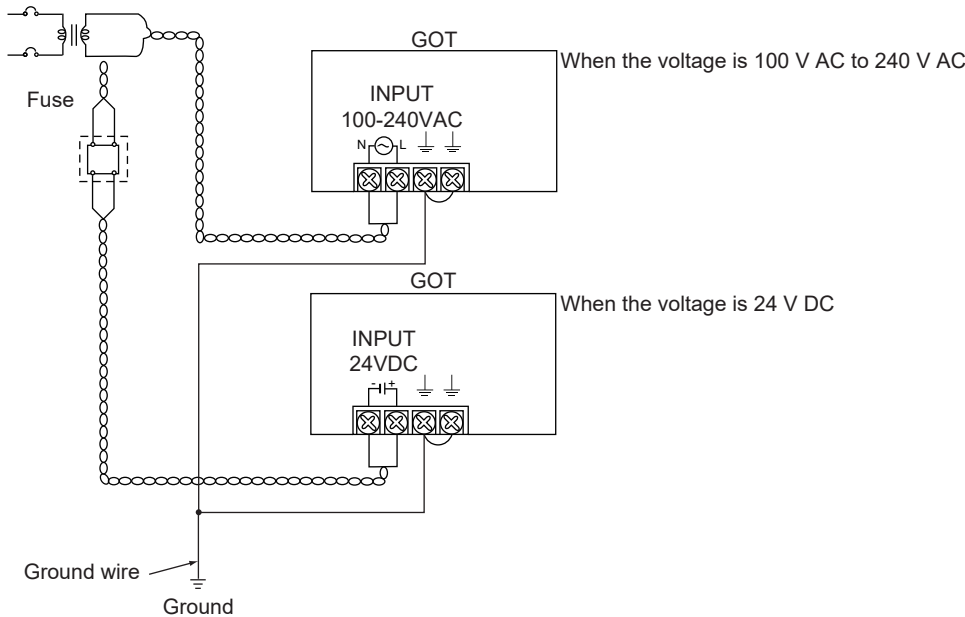

Precautions

■Treatment of the power cables

For the power cables (AC and DC power cables), use the thickest wire possible (cable cross section: 0.75 mm² to 2 mm²), and make sure to twist them before inserting them into the terminals.

To prevent a short circuit due to loose screws, use a solderless terminal with an insulation sleeve.

■Grounding

After connecting the LG terminal and the FG terminal, make sure to connect them to the ground.

Otherwise, the system is susceptible to noise.

The LG terminal has a potential equal to a half of the input voltage.

Therefore, touching the terminal may lead to an electric shock.

■Recommended terminal shape

It is recommended to use the following applicable solderless terminals for the power supply wiring of the GOT.

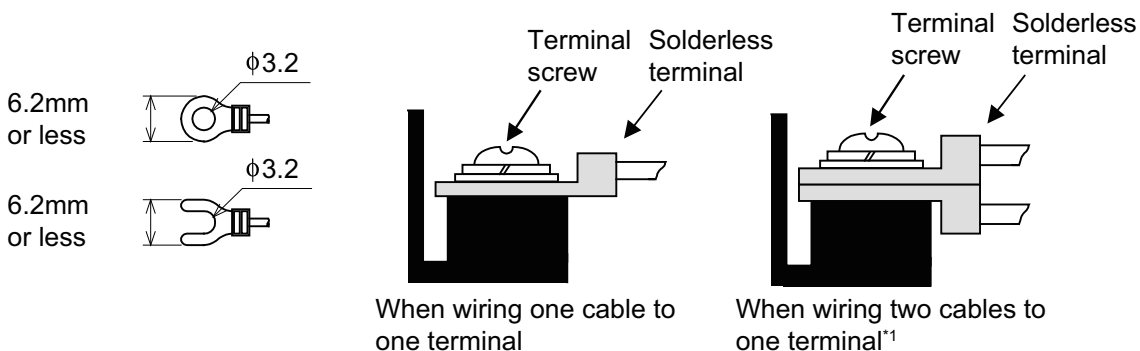

*1 Applicable to V2-N3A and FV2-N3A only

Manufacturer	Model	Applicable wire	Certification	Crimp tool
J.S.T. Mfg. Co., Ltd.	RAA1.25-3	AWG 18 to AWG 16	UL Listed CSA Listed	YA-1 (J.S.T. Mfg. Co., Ltd.)
	V2-S3.3	AWG 16 to AWG 14		
	V2-N3A			
	FV2-N3A			

25 Grounding

☞ Page 105 Grounding the GOT

☞ Page 108 Causes of wiring-related malfunction and countermeasure examples

The GOT has the following ground terminals:

- FG terminal
- LG terminal

Precautions

When using the GOT, be sure to ground it.

In particular, for GT37-W, not grounding the FG terminal can cause significant deterioration in touch panel response and operability.

25.1 Grounding the GOT

☞ Page 105 Grounding method

☞ Page 106 Grounding examples

25.1.1 Grounding method

Ground the GOT independently as much as possible.

If independent grounding cannot be applied to the GOT, use shared grounding as shown in (2) below.

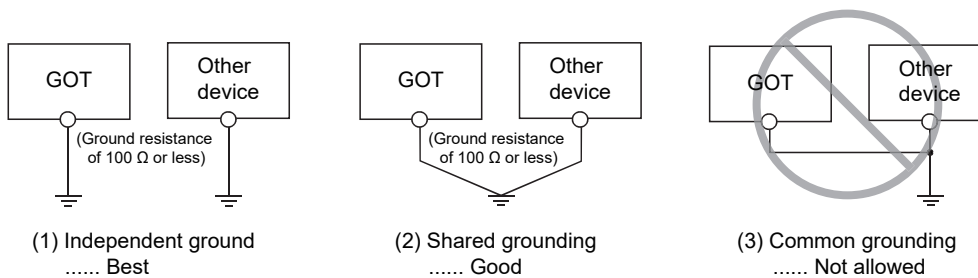

For both (1) and (2) above, use a cable with a cross section of 2 mm² or more.

Place the ground point as close to the GOT as possible to shorten the ground cable.

25.1.2 Grounding examples

Independent grounding (Best)

For grounding for control system, ground the system at one end.

Especially for the control devices communicating each other, ground the system at one end.

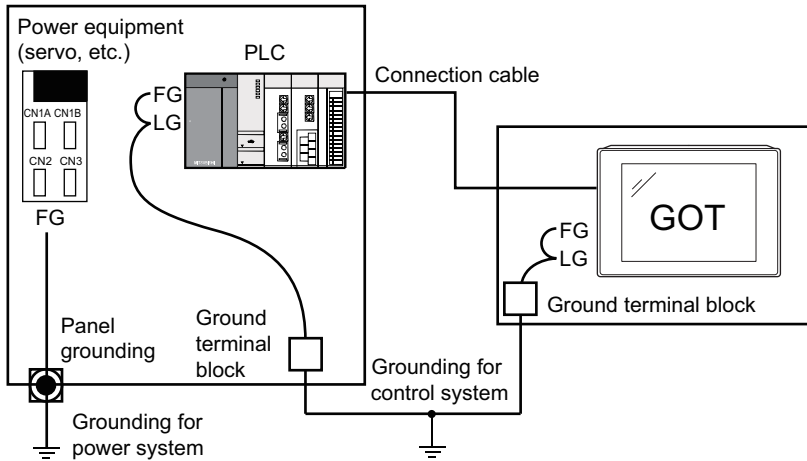

Shared grounding (Good)

Ground the system at one end.

To prevent noise from entering the GOT, use a short and thick wire for grounding between the ground and the control panel to lower ground resistance.

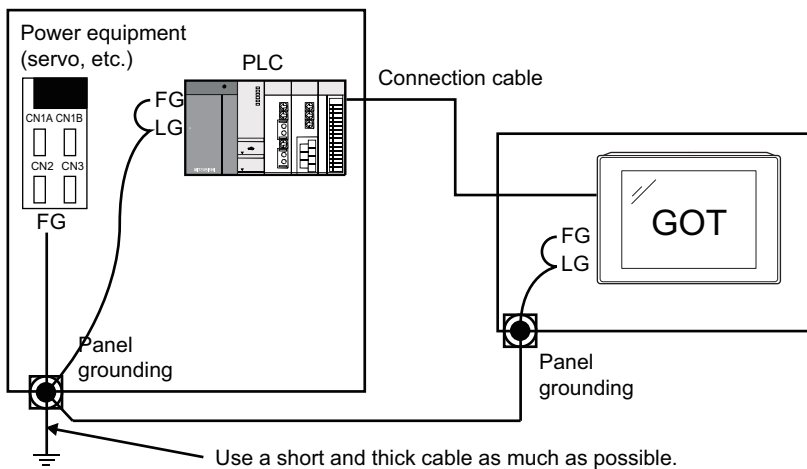

Common grounding (Not allowed)

Do not connect the ground cables of the power equipment and control equipment with a wire.

When the cables are connected, noise from the power equipment may affect the control equipment, causing a malfunction.

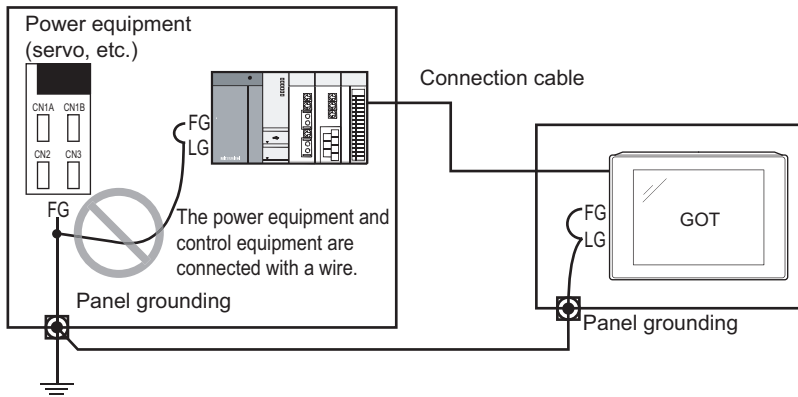

25.2 Causes of wiring-related malfunction and countermeasure examples

Causes of a malfunction due to grounding of the GOT include potential difference caused by grounding and noise.

The following measures may reduce potential difference and noise.

☞ Page 108 Wiring of the ground cable and power line of the GOT

☞ Page 108 Leading the ground cable to the control panel with the GOT

25.2.1 Wiring of the ground cable and power line of the GOT

When the ground cable and power line of the GOT are installed together, the GOT may malfunction due to noise.

Separating the ground cable and power line of the GOT in wiring reduces the influence of noise.

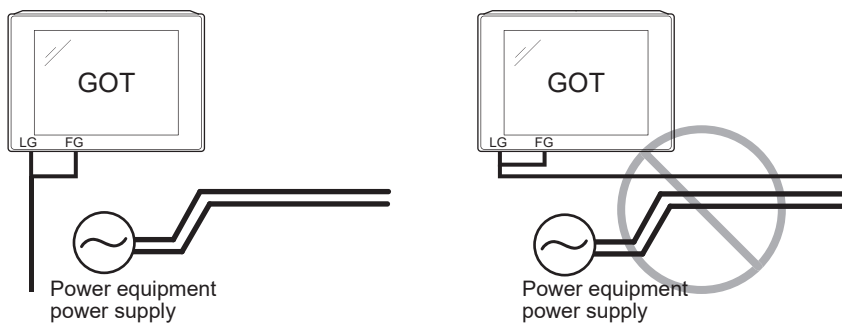

Good example:
Ground wire and power wires are separate

Bad example:
Ground wire and power wires are bundled together

25.2.2 Leading the ground cable to the control panel with the GOT

When a single ground cable is led from the control panel having control equipment, including a PLC, into the control panel having the GOT, the cable may be directly connected to the power supply terminals of the GOT.

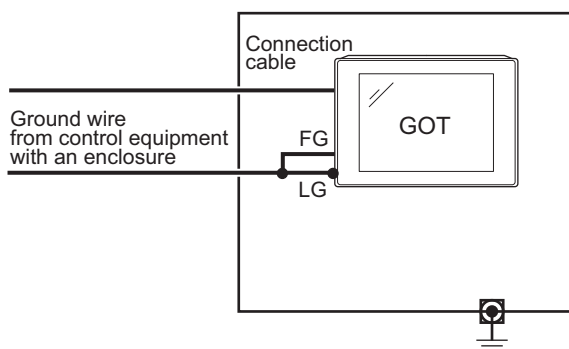

The malfunction due to the potential difference caused by the grounding in such a case may be prevented by reducing the voltage as shown in countermeasure example 1 below.

Countermeasure example 1

When any potential difference between the ground cable and the control panel having the GOT affects the GOT, also connect the ground cable to the control panel.

When Countermeasure example 1-1 is difficult to be taken, such as the wiring is impossible, carry out wiring as shown in Countermeasure example 1-2.

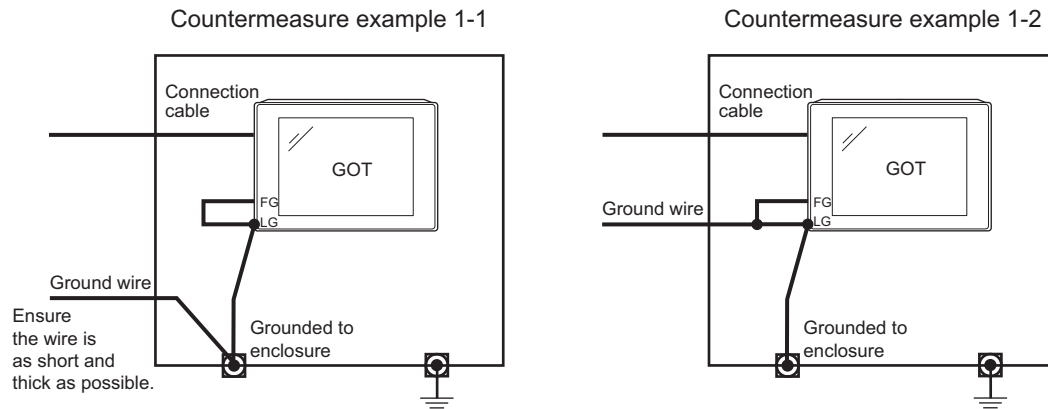

If the noise further affects the GOT by taking Countermeasure example 1, Countermeasure example 2 may reduce the influence of noise.

Countermeasure example 2

If the noise from the control panel with the GOT adversely affects the GOT even after Countermeasure example 1, attach a ferrite core (KITAGAWA INDUSTRIES CO.,LTD. RFC-H13 or equivalent).

When attaching a ferrite core, insert the cable through the ferrite core several times (approximately three times).

When Countermeasure example 2-1 is difficult to be taken, such as the wiring is impossible, carry out wiring as shown in Countermeasure example 2-2.

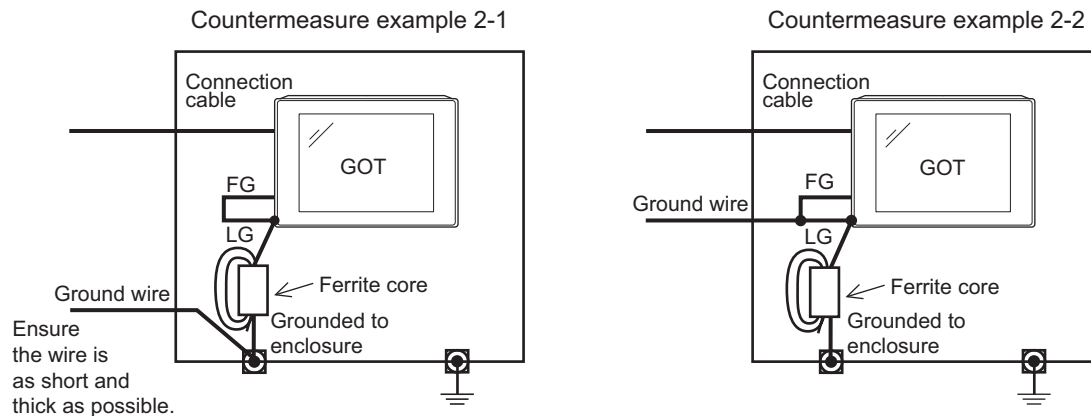

26

Wiring inside and outside the control panel

☞ Page 110 Control panel inside wiring

☞ Page 111 Control panel outside wiring

26.1 Control panel inside wiring

Wire the power lines such as power cables and servo amplifier drive cables separately from communication cables such as network cables, as shown in the diagram below.

Mixing the power lines and communication cables may cause a malfunction due to noise.

When devices that generate surge noise, including molded case circuit breakers (MCCB), electromagnetic contactors (MC), relays (RA), solenoid valves, and induction motors are used, a surge suppressor is effective.

For the surge suppressor, refer to the following.

☞ Page 112 Attaching a surge suppressor to control equipment

Power lines and communication cables are separated

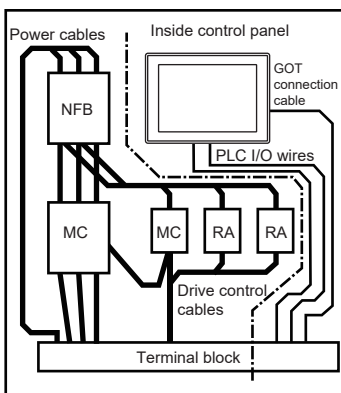

Power lines and communication cables are not separated

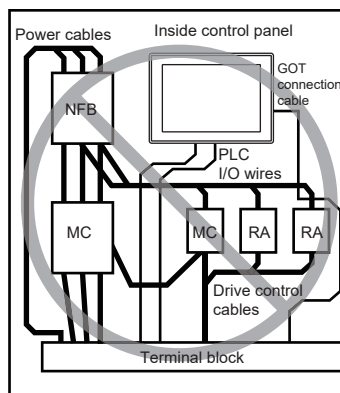

26.2 Control panel outside wiring

To lead the power lines and the communication cable outside the control panel, open cable holes at two separate places to lead the cables separately out.

When the cables are led out through the same cable hole for wiring reasons, the cables are more easily affected by noise.

Routing the power lines and communication cables out of the enclosure

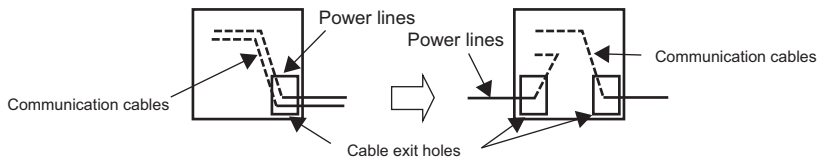

Separate the power lines and communication cables 100 mm or more from each other in the duct.

If the wiring needs to be close due to space constraints, use separators (made of metal) inside the duct.

Doing so reduces the noise influence.

Routing the power lines and communication cables inside the duct

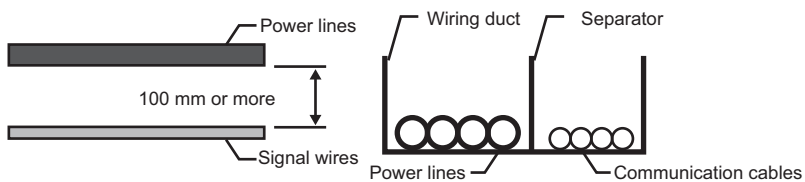

27

Attaching a surge suppressor to control equipment

When the GOT fails to work properly, for example a communication error occurs, in synchronization with the ON/OFF status of the specific control equipment, including a molded case circuit breaker, electromagnetic contactor, relay, solenoid valve, and induction motor (hereinafter described as load), the GOT may be affected by surge noise.

In such instances, separate the ground cable and the communication cable from the load.

When the ground cable or communication cable has to be installed close to the load, attaching a surge suppressor is effective.

Attach a surge suppressor closest to the load.

Countermeasure for AC inductive load

Do not route the GOT ground wire and communication cable close to the PLC.

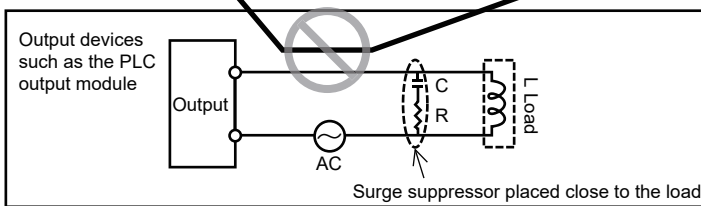

Countermeasure for DC inductive load

Do not route the GOT ground wire and communication cable close to the PLC.

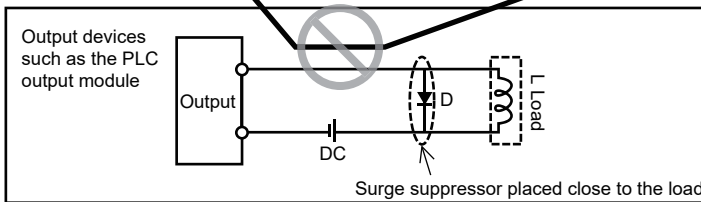

PART 8

Maintenance and inspection

28 Inspection

29 Screen cleaning method

30 Low-voltage battery detection and replacement

28 Inspection

☞ Page 116 Daily inspection

☞ Page 117 Periodic Inspection

WARNING

- Do not touch the terminals while power is on.
Close the terminal block cover before supplying power.
Not doing so may cause an electric shock or malfunction.
- Correctly connect the battery connector.
Do not perform the following actions on the battery:
 - Charging, disassembling, heating, throwing into fire, short-circuiting, soldering, etc.Improper handling of the battery may cause heat generation, explosion, or ignition, resulting in injury or fire hazards.
- Before cleaning or terminal screw retightening, make sure to shut off all phrases of the external power supply.
Not doing so may cause the unit to fail or malfunction.
Undertightening may cause a short circuit or malfunction.
Overtightening may cause a short circuit or malfunction due to damage to the screws or unit.

CAUTION

- Do not disassemble or modify the unit.
Doing so can cause a failure, malfunction, injury or fire.
- Do not touch the conductive and electronic parts of the unit directly.
Doing so may cause a unit malfunction or failure.
- The cables connected to the unit must be run in ducts or clamped.
Not doing so can cause the unit or cable to be damaged due to the dangling, motion or accidental pulling of the cables, or can cause a malfunction due to a cable connection fault.
- When unplugging the cable connected to the unit, do not hold and pull from the cable portion.
Doing so can cause the unit or cable to be damaged or can cause a malfunction due to a cable connection fault.
- Do not drop the unit or subject it to strong shock.
A unit damage may result.
- Do not drop or give an impact to the battery mounted to the unit.
Doing so may damage the battery, causing the battery fluid to leak inside the battery.
If the battery is dropped or given an impact, dispose of it without using it.
- Before touching the unit, always touch grounded metals, etc. to discharge static electricity from human body, etc.
Not doing so may cause the unit to fail or malfunction.
- Use the battery manufactured by Mitsubishi Electric Corporation.
Use of other batteries may cause a risk of fire or explosion.
- Dispose of the used battery promptly.
Keep it away from children.
Do not disassemble and dispose of it in fire.
- Before replacing the battery or setting the terminating resistor using a selector switch, make sure to shut off all phases of the external power supply.
Not doing so can cause the unit to fail or malfunction due to static electricity.
- When setting the terminating resistor using the selector switch, do not use a pointed metal object.
- When the extension unit is not used, do not leave it uncovered.
Otherwise, the unit may fail or malfunction due to static electricity.
- Turn off the power when cleaning the GOT.
Also, before cleaning, ensure that the GOT is properly installed on the control panel.
- Visually check the protective sheet every day.
If you find extreme dirt or scratches on the surface, immediately replace it with a new one.
Using the sheet with decreased visibility may cause malfunction.

28.1 Daily inspection

The GOT does not have consumables that contribute to a shortened life.

However, the battery and liquid crystal display have limited life.

When a battery is used, periodic replacement is recommended.

For replacing the liquid crystal display, consult your local sales office.

For the specifications of the battery and the liquid crystal display, refer to the following.

 Page 42 GT37

Daily inspection items

Item	Inspection item		Inspection method	Criterion	Corrective action
1)	GOT installation status		Check for loose screws.	Securely tightened	Retighten the screws with the specified torque.
2)	Connection status	Loose terminal screws	Retighten the screws with a screwdriver.	Not loose	Retighten the terminal screws.
		Proximity of solderless terminals	Visual check	Proper intervals	Correct intervals.
		Loose contactors	Visual check	Not loose	Retighten the connector fixing screws.
3)	Usage status	Dirt on the protective sheet	Visual check	Not outstanding	Replace the sheet with a new sheet.
		Adhesion of debris or foreign matter	Visual check	No foreign matter adherence	Remove the foreign material and clean.

For the model of the protective sheet and the replacement procedure, refer to the following.

 User's manual of the protective sheet

28.2 Periodic Inspection

Half-yearly or yearly inspection items

Perform the following inspections when relocating or modifying the equipment or changing the wiring.

Item	Inspection item		Inspection method	Criterion	Corrective action
1)	Surrounding environment	Ambient temperature	Measurement with a thermometer	0°C to 55°C*1	For use in a control panel, the control panel inside temperature is the ambient temperature.
		Ambient humidity	Measurement with a hygrometer	10% RH to 90% RH	
		Atmosphere	Measurement of corrosive gas	No corrosive gas	
2)	GOT with a power supply of 100 V AC to 240 V AC	Power supply voltage check	Voltage measurement between 100 V AC and 240 V AC terminals	100 V AC to 240 V AC (+10%, -15%)	Change the power supply.
	GOT with 24 V DC power	Input polarity of 24 V DC power	Measure voltage across 24 V DC terminals.	Connected according to terminal markings on the GOT power supply section	Change wiring.
3)	Installation status	Looseness	Move the unit.	Installed firmly	Retighten the screws.
		Adhesion of debris or foreign matter	Visual check	No foreign matter adherence	Remove the foreign material and clean.
4)	Connection status	Loose terminal screws	Retighten the screws with a screwdriver.	Not loose	Retighten the terminal screws.
		Proximity of solderless terminals	Visual check	Proper intervals	Correct intervals.
		Loose contactors	Visual check	Not loose	Retighten the connector fixing screws.
5)	Battery		Check the voltage status of the GOT built-in battery in [Time] of the utility function.  GOT3000 Series User's Manual (Utility & Maintenance Functions)	No alarm	Even if the battery voltage is not low, replace the battery when the specified life is exceeded.

*1 The criterion varies with the installation orientation.

For details, refer to the following.

 Page 71 Control panel inside temperature and GOT installation angle

29 Screen cleaning method

Use the GOT always in a clean condition.

Cleaning and disinfecting the GOT

- For your safety, be sure to turn off the GOT before cleaning and disinfecting the GOT.
- Carefully wipe the GOT screen with a soft cloth moistened with neutral detergent or ethanol.

Do not apply too much disinfectant to the cloth.

When using alcohol for disinfection, use disinfectant alcohol (with ethanol or isopropyl alcohol as the main component).

- Do not spray disinfectant directly on the GOT. Doing so may cause electrical failure of the GOT and peripheral devices.
- After wiping the surface, dry the GOT completely before turning it on.

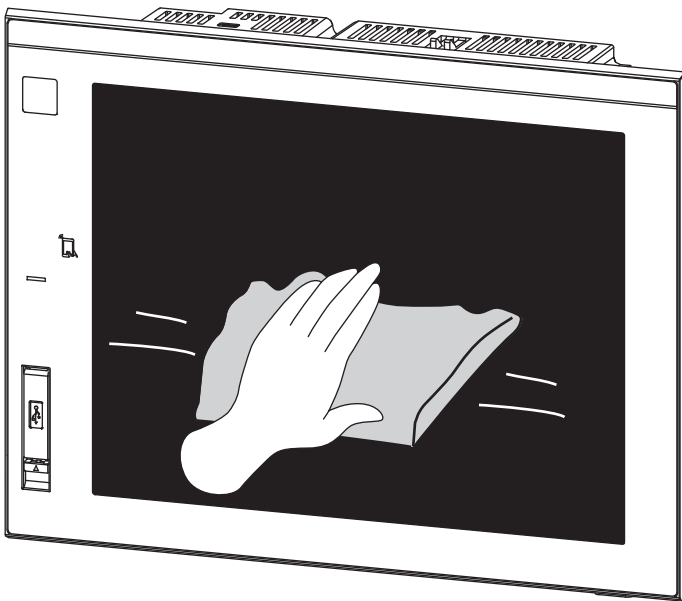

Precautions

Do not use the following solvents.

Solvents may deform the protective sheet, dissolve the surface, or peel the paint on the surface.

- Chlorine-based cleaners (bleach or other solvents)
- Peroxides (including hydrogen peroxide)
- Acetone, ammonia, paint thinner, benzene, methylene chloride, toluene, or other solvents

30 Low-voltage battery detection and replacement

☞ Page 119 Low-voltage battery detection and replacement

☞ Page 120 Handling of batteries and devices with built-in batteries in EU member states

30.1 Low-voltage battery detection and replacement

The battery is used to hold the clock data.

Periodic battery replacement is recommended.

For the battery replacement procedure, refer to the following.

☞ Page 82 Installing and removing the battery

You can check if the battery has a low voltage by using the utility and the system alarm.

For details of the battery status display by using the utility, refer to the following.

📖 GOT3000 Series User's Manual (Utility & Maintenance Functions)

The GOT can display a low battery voltage message with the system alarm on such an occasion.

To display the message by the system alarm, set [Battery alarm display] to ON.

📖 GOT3000 Series User's Manual (Utility & Maintenance Functions)

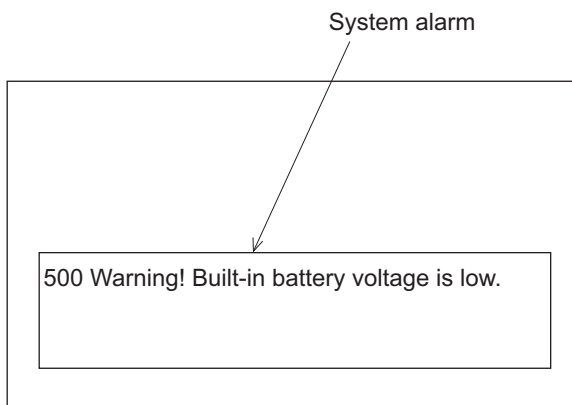

For details on the system alarm, refer to the following.

📖 GT Designer3 (GOT3000) Screen Design Manual

Precautions

When a low-voltage battery is detected, replace the battery immediately.

The GOT retains the data for 14 days after the low-voltage battery detection. However, after the period, the GOT cannot retain the data.

30.2 Handling of batteries and devices with built-in batteries in EU member states

This section explains the precautions for disposing of waste batteries in EU member states and for exporting batteries and devices with built-in batteries to EU member states.

📖 Page 120 Precautions for disposal

📖 Page 120 Precautions for export

Precautions for disposal

EU member states have a separate collection system for waste batteries.

Dispose of batteries properly at the local community waste collection/recycling center.

The following symbols are printed on batteries and the packaging of devices with built-in batteries.

If any chemical symbol is printed under the symbol (1), it indicates that the battery contains heavy metals at or above the following concentrations:

- Hg: Mercury (0.0005%), Cd: Cadmium (0.002%), Pb: Lead (0.004%)

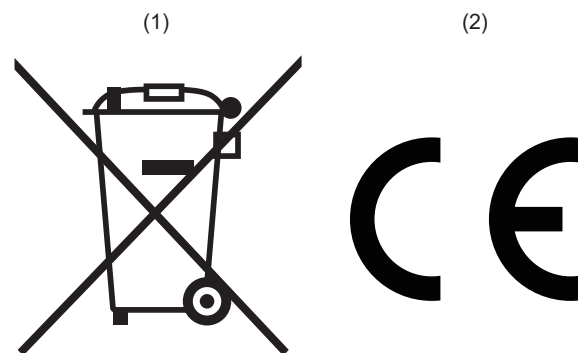

* The symbols on the left are specified according to the following:

(1): New EU Battery Directive (2006/66/EC)

(to be repealed on August 18, 2025)

(1) and (2): EU Battery Regulation (EU 2023/1542)

Precautions for export

When batteries are sold or exported to EU member states, the following measures are required:

- Display the symbols on the battery (or in the manual and on the packaging if not possible).
- Explain the symbols in the manual.

■ Displaying the symbols

From August 18, 2024 onward, display the separate collection symbol and the CE mark on the battery or on the manual and packaging, as described in the disposal precautions, to comply with the EU Battery Regulation (EU 2023/1542).

When selling or exporting the product to EU member states before August 18, 2024, display the separated collection symbol on the product or packaging in accordance with the new EU Battery Directive (2006/66/EC).

■ Adding an explanation of the symbols to the relevant manual

When exporting equipment incorporating this product to EU member states on/after August 18, 2024, provide the latest version of the manual included with this product which explains the separate collection symbol and the CE mark.

If this manual is not included with the equipment or older versions of the manual are included, add an explanation of the symbols to the manuals of the equipment.

Point

Batteries manufactured before the new EU Battery Directive (2006/66/EC) or EU Battery Regulation (EU 2023/1542) take effect are also subject to the restrictions.

PART 9

Troubleshooting

31 GOT restoration sheets

32 Error messages and system alarms

31 GOT restoration sheets

☞ Page 123 GOT status check sheet

☞ Page 130 GOT installation status check sheet

☞ Page 137 System configuration check sheet

This chapter provides check sheets for restoration in cases where the GOT does not operate normally.

The following explains how to use each sheet.

When the GOT does not operate or malfunctions (GOT status check sheet)

When the GOT does not operate or malfunctions, identify the cause of the malfunction using the GOT status check sheet, and take corrective action.

Keep an eye on the performance of the GOT for a while once it has been restored.

When the wiring needs to be improved (GOT installation status check sheet)

As a result of the GOT status check, if the cause of the malfunction or others is due to the noise generated by the GOT wiring status, take a corrective action for wiring by using the GOT installation status check sheet.

Keep an eye on the performance of the GOT for a while once it has been restored.

When a corrective action other than the above is required (System configuration check sheet)

If a malfunction or other problems still occur even after the above corrective actions, fill out the system configuration check sheet with details about your system, and consult your local sales office.

When sending a faulty product, attach the GOT restoration sheets (GOT status check sheet, GOT installation status check sheet, and the system configuration check sheet) that have been completed in this chapter.

Keep copies of the GOT restoration sheets.

31.1 GOT status check sheet

Check the GOT, starting from the GOT status.

Mark checkboxes that apply to the symptoms of your GOT.

Proceed according to the corrective actions.

31.1.1 GOT status

Check the frequency of failures, such as the GOT not operating and errors appearing on the screen

Check	Symptom	Cause	Corrective action
<input type="checkbox"/>	Always occurs.	Frequency:	Proceed to the following.
<input type="checkbox"/>	Occurs sometimes.	• Example: Once a month	☞ Page 123 Check of the displayed error code (system alarm)

Check of the displayed error code (system alarm)

Check	Symptom	Cause	Corrective action
<input type="checkbox"/>	Can be checked.	Error code (system alarm):	Take the corrective action for the error code (system alarm) or error message. If the corrective action does not resolve the issue, proceed to the following. ☞ Page 123 Check of the POWER LED
<input type="checkbox"/>	Cannot be checked.	• Example: 460 Communication unit error	Proceed to the following. ☞ Page 123 Check of the POWER LED

Check of the POWER LED

Check	Symptom	Cause/status	Corrective action
<input type="checkbox"/>	Lit in lime green.	The power is supplied normally.	Proceed to the following. ☞ Page 123 Screen display check
<input type="checkbox"/>	Blinking in lime green (fade-out and fade-in)	Screen saving is being performed. When the read device of the system information was set, the device was turned on and the screen was switched to the forced screen saving status.	Check the setting of the read device. If no problem is found in the setting, proceed to the following. ☞ Page 123 Screen display check
<input type="checkbox"/>	Blinking in lime green	A backlight failure has occurred.	Proceed to the following. ☞ Page 129 Faulty product investigation
<input type="checkbox"/>	Not lit	The power is not supplied. If the power is supplied, the GOT hardware may be faulty.	Check if the power is supplied. If the GOT is not restored, proceed to the following. ☞ Page 129 Faulty product investigation

Screen display check

Check	Symptom	Cause/status	Corrective action
<input type="checkbox"/>	The screen is black.	The LCD or basic software may be faulty.	Perform the following in order. 1) Write the package data again. 2) Install the basic software again. If the GOT is not restored by the above operations, proceed to the following. ☞ Page 129 Faulty product investigation
<input type="checkbox"/>	The screen is white.	The GOT hardware may be faulty.	Proceed to the following. ☞ Page 129 Faulty product investigation
<input type="checkbox"/>	A line is displayed on the screen.	The GOT hardware may be faulty. Example: A vertical line appears on the screen.	
<input type="checkbox"/>	Other display faults		
<input type="checkbox"/>	The screen freezes.	The screen display is not updated and operation is unavailable.	Proceed to the following. ☞ Page 124 Buzzer sound check

Buzzer sound check

Check	Symptom	Cause/status	Corrective action
<input type="checkbox"/>	No buzzer sound	—	Proceed to the following.
<input type="checkbox"/>	Continues to beep randomly.	Buzzer sound: • Example: The buzzer repeats in the rhythm of "beep-beep-beep, beep, beep-beep".	☞ Page 125 Status of the GOT when it freezes (screen operation stopped)
<input type="checkbox"/>	Continues to beep in a particular pattern.		
<input type="checkbox"/>	Beeps continuously.	When the read device of the system information was set, the device was turned on and the Buzzer Output signal was input.	Check the setting of the read device. If the Buzzer Output signal has no error, proceed to the following. ☞ Page 125 Status of the GOT when it freezes (screen operation stopped)

31.1.2

Status of the GOT when it freezes (screen operation stopped)

Check of switching to the utility screen

Check	Symptom	Cause/status	Corrective action
<input type="checkbox"/>	Possible	Error code (system alarm): • Example: 460 Communication unit error	When the system alarm display function can be used, take the action for the error code (system alarm) displayed. If the corrective action cannot be taken, proceed to the following. ☞ Page 125 Executing memory check for each drive from the GOT utility
<input type="checkbox"/>	Impossible	The system alarm cannot be used.	Proceed to the following. ☞ Page 126 Check of the objects that are not displayed on the monitor screen

Executing memory check for each drive from the GOT utility

Check	Symptom	Cause/status	Corrective action
<input type="checkbox"/>	Normally ended.	There is no error in the specified drive. Execution result: • Example: Normally ended.	Proceed to the following. ☞ Page 125 Executing the I/O check from the GOT utility
<input type="checkbox"/>	An error is detected.	The specified drive is faulty. Execution result: • Example: Error	Replace the data storage. If the error persists after replacement or if the built-in flash memory is checked, proceed to the following. ☞ Page 129 Faulty product investigation

Executing the I/O check from the GOT utility

Check	Symptom	Cause/status	Corrective action
<input type="checkbox"/>	Communication error	Display details: • Example: A message indicating that the cause may be a connection error has been displayed.	For the Ethernet connection, proceed to the following. ☞ Page 125 Executing the Ethernet status check from the GOT utility Otherwise, proceed to the following. ☞ Page 126 Check of the objects that are not displayed on the monitor screen
<input type="checkbox"/>	No error	The hardware such as a communication interface has no error.	

Executing the Ethernet status check from the GOT utility

Check	Symptom	Cause/status	Corrective action
<input type="checkbox"/>	Communication error	Display details: • Example: There is no response.	Check the connection settings of the GOT and the controller. If no problem is found in the settings, proceed to the following. ☞ Page 126 Check of the objects that are not displayed on the monitor screen
<input type="checkbox"/>	No error	The hardware such as a communication interface has no error.	Proceed to the following. ☞ Page 126 Check of the objects that are not displayed on the monitor screen

Check of the objects that are not displayed on the monitor screen

Check	Symptom	Cause/status	Corrective action
<input type="checkbox"/>	Found	Details: • Example: The numerical display object is not displayed.	Proceed to the following. ☞ Page 127 PLC status
<input type="checkbox"/>	Not found		

31.1.3

PLC status

PLC failure

Check	Symptom	Cause/status	Corrective action
<input type="checkbox"/>	Always occurs.	CONTROL-BUS. ERROR, SP. UNIT LAY. ERROR, or others is considered. Error code (system alarm): • Example: 1204 CPU H/W failure	Check the status of the controller for any errors.
<input type="checkbox"/>	Occurs sometimes.	The PLC CPU may be affected by noise or the hardware may be faulty. Frequency: • Example: Once a month Error code (system alarm): • Example: 1204 CPU H/W failure	Proceed to the following.  Page 128 GOT restoration procedure
<input type="checkbox"/>	Operates normally.	—	

31.1.4 GOT restoration procedure

Follow the procedure below starting from 1), and check if the GOT is restored.

Perform the action in each check item and mark the corresponding checkbox.

If the GOT is restored, take the action after restoration.

If the GOT is not restored, proceed to the next check item.

No.	Check item	Check	Cause/status	Action after restoration
1)	Press the GOT reset switch.*1*3	<input type="checkbox"/> Restored <input type="checkbox"/> Not restored	If the GOT is restored by the operation on the left, a temporary malfunction or others due to noise is considered.	Perform the following. ☞ Page 130 GOT installation status check sheet
2)	Power on/off the GOT.*2*3	<input type="checkbox"/> Restored <input type="checkbox"/> Not restored		
3)	Reset or power on/off the PLC CPU.	<input type="checkbox"/> Restored <input type="checkbox"/> Not restored		
4)	Power on/off the GOT and PLC CPU simultaneously.	<input type="checkbox"/> Restored <input type="checkbox"/> Not restored		
5)	Connect the cable again.	<input type="checkbox"/> Restored <input type="checkbox"/> Not restored	If the GOT is restored by the operation on the left, the cable connection may be faulty.	Securely connect the cable. If an error occurs again, proceed to the following. ☞ Page 129 Faulty product investigation
6)	Write the package data again.	<input type="checkbox"/> Restored <input type="checkbox"/> Not restored	If the GOT is restored by the operation on the left, data may have been destroyed by an action such as powering off the GOT during the package data writing or basic software installation.	Do not power off the GOT during data transfer. If an error occurs again, proceed to the following. ☞ Page 129 Faulty product investigation
7)	Install the basic software again.	<input type="checkbox"/> Restored <input type="checkbox"/> Not restored		
8)	Take the preventive measures against noise, which is described in the following. ☞ Page 130 GOT installation status check sheet	<input type="checkbox"/> Restored <input type="checkbox"/> Not restored	A temporary malfunction or others due to noise is considered.	Perform the following. ☞ Page 130 GOT installation status check sheet
9)	Replace the unit.	<input type="checkbox"/> Restored <input type="checkbox"/> Not restored	If the GOT is restored by the operation on the left, the unit may has a hardware failure.	Install the failed unit on the GOT again to check that the unit causes the malfunction. After checking, proceed to the following. ☞ Page 129 Faulty product investigation
10)	If the GOT is not restored by 1) to 9), proceed to the following. ☞ Page 129 Faulty product investigation			

*1 The GOT reset switch does not function when bus connection is used.

*2 When using bus connection, do not turn on the GOT power while the PLC power is on.
Make sure to turn off the PLC power first, then turn the GOT power off and on.

*3 Powering off the GOT causes an error in the control station for the MELSECNET/H connection or in the master station for the CC-Link connection (intelligent device station).

31.1.5 Faulty product investigation

If you cannot restore the GOT, consult your local sales office.

Depending on the problem details, we may ask you to send the faulty product to us.

In such instances, attach the GOT status check sheet, GOT installation status check sheet, and system configuration check sheet with details filled in about your system.

31.2 GOT installation status check sheet

Check the installation status of your GOT regarding the following items.

- ☞ Page 130 Control panel inside wiring
- ☞ Page 131 Control panel outside wiring
- ☞ Page 132 Wiring of the FG cable and power line for the GOT
- ☞ Page 133 Surge protection
- ☞ Page 134 Installation status
- ☞ Page 135 Grounding status of the control panel having the GOT
- ☞ Page 136 Power supply system

Mark the checkboxes that apply to the current status, and take the relevant measures if necessary.

If measures are taken, mark the applicable checkboxes.

Point

The GOT has the following ground terminals:

- FG terminal and LG terminal

31.2.1 Control panel inside wiring

Current status

Check if power lines, such as power cables and servo amplifier driving cables, and communication cables, such as network cables, are mixed together in the wiring duct inside the control panel.

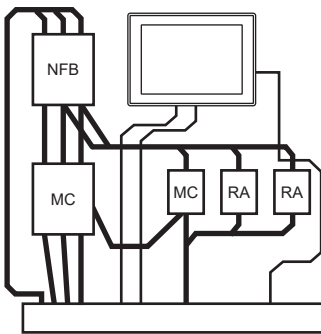

Check result

- Mixed
- Not mixed

Countermeasure if applicable

Wiring the power lines and communication cables inside the control panel without mixing them together in the duct reduces the effect of noise.

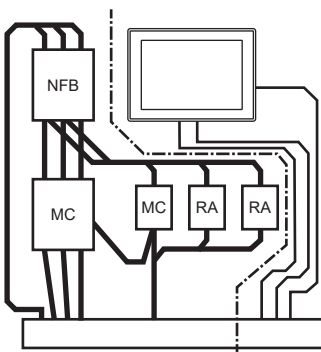

Effect

- Effective
- Ineffective

31.2.2

Control panel outside wiring

Current status

Check if the power line and the communication cable are installed together.

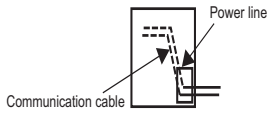

Check result

- Installed together
- Not installed together

Countermeasure if applicable

As shown in the figure below, leading the power line and communication cable separately from different places to the outside of the control panel reduces the influence of noise from the power line.

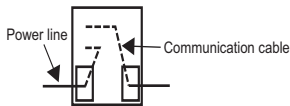

Effect

- Effective
- Ineffective

Separating the communication cable from the power line or using a separator (made of metal) in the duct, as shown below, reduces the effect of noise.

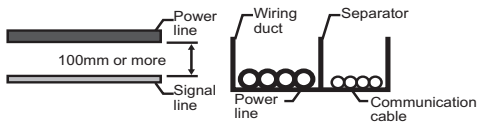

Effect

- Effective
- Ineffective

31.2.3

Wiring of the FG cable and power line for the GOT

Current status

Check if the FG cable and power line of the GOT are installed together.

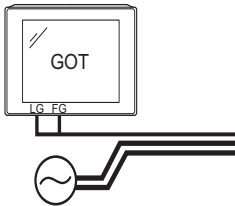

Power for the power equipment

Check result

- Installed together
- Not installed together

Countermeasure if applicable

Separating the FG cable and power line of the GOT reduces the effect of noise.

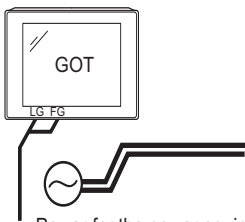

Power for the power equipment

Effect

- Effective
- Ineffective

31.2.4

Surge protection

Current status

Check if a surge suppressor is used for the wiring of the load such as a molded case circuit breaker, electromagnetic contactor, relay, solenoid valve, or induction motor.

When a surge suppressor is used, enter the surge suppressor model and the name of the equipment that uses the surge suppressor in the columns.

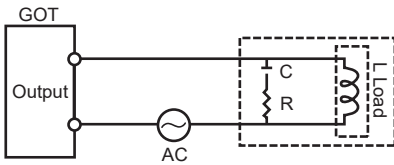

- Check result
- Used
 - Not used

• Entry column

Surge suppressor model	Equipment name

Countermeasure when a surge suppressor is not used

Attaching a surge suppressor close to the load reduces the effect of surge on the GOT.

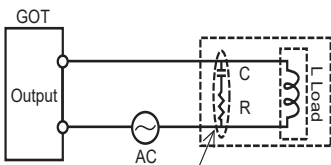

Place the surge suppressor close to the load

- Effect
- Effective
 - Ineffective

31.2.5 Installation status

Current status

Check if the FG cables of the control equipment (such as a PLC) and the power equipment (such as a servo amplifier) are connected as shown in "a" of the following figure.

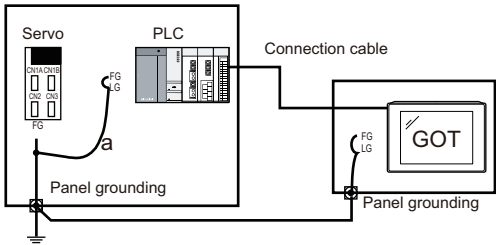

- Check result
- Applicable
 - Not applicable

Countermeasure if applicable

Perform independent grounding at two places as shown in Figure A.

The independent grounding reduces the effect of noise.

When independent grounding is unavailable, perform shared grounding as shown in Figure B.

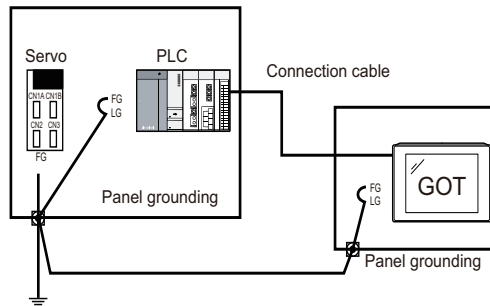
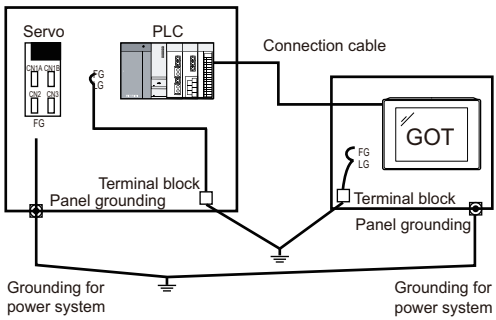

- Effect
- Effective
 - Ineffective

31.2.6

Grounding status of the control panel having the GOT

Current status

Check if a single ground cable is led from the control panel having the control equipment such as a PLC to the control panel having the GOT.

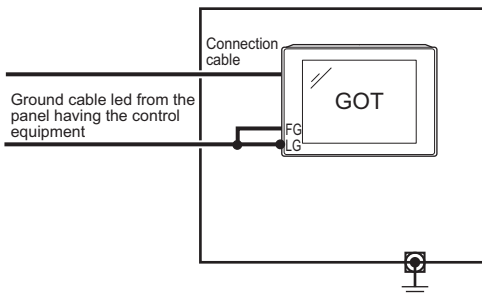

- Check result
- Applicable
 - Not applicable

Countermeasures if applicable

Countermeasure 1

A malfunction may be prevented by connecting the ground cable to the control panel having the GOT as shown in Figure A to reduce the potential difference.

If wiring as shown in Figure A is unavailable, perform wiring as shown in Figure B.

Fig. A

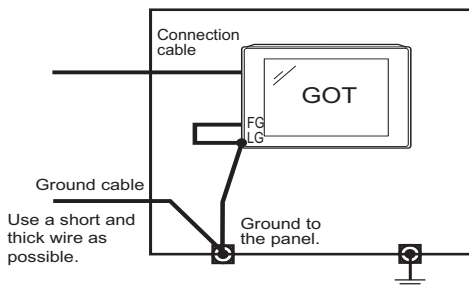
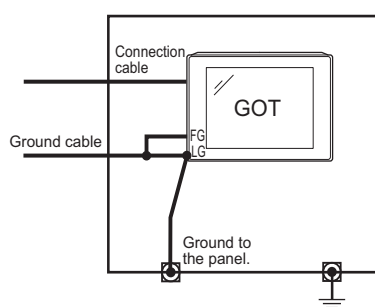

Fig. B



- Effect
- Effective
 - Ineffective

Countermeasure 2

By attaching a ferrite core (TDK Corporation ZCAT3035-1330 or equivalent) to the ground cable connected to the control panel with the GOT as shown in Figure C, the effect of noise is reduced.

If wiring as shown in Figure C is unavailable, perform wiring as shown in Figure D.

Fig. C

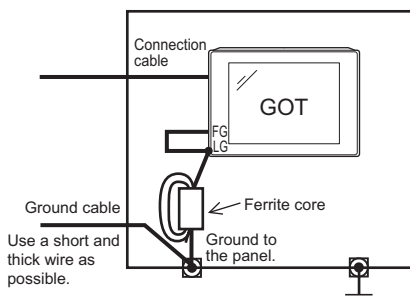
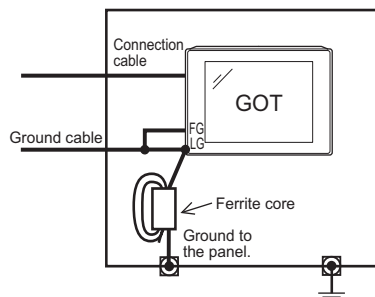

Fig. D



- Effect
- Effective
 - Ineffective

31.2.7 Power supply system

Current status

Check if the power is supplied for the GOT, I/O equipment (such as a relay), and power equipment (such as a servo amplifier) from the same system.

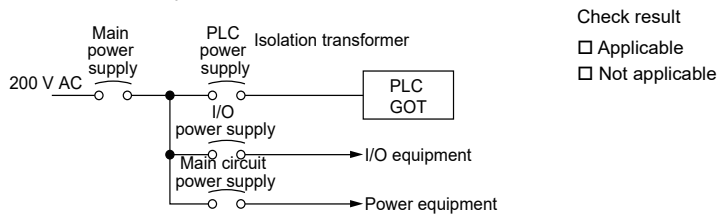

Countermeasure if applicable

By separately wiring the GOT power and the I/O equipment power/power equipment power, and connecting an isolation transformer, the effect of noise is reduced.

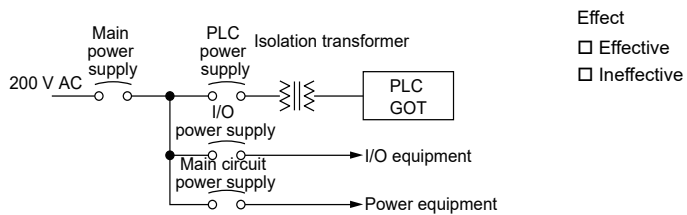

31.3 System configuration check sheet

Fill in the following table with the details of the system configuration, such as the GOT type and unit model.

System configuration for the GOT

Item	System configuration	
	Usage	Model
GOT (Example: GT3715-FHCBD)	—	
Communication interface	Communication unit	Used, Not used
	GOT built-in interface	Used, Not used
Option unit	Used, Not used	
Cable between the controller and GOT	—	
Cable length	—	
When using any other units or options, describe them.		

System configuration for the PLC

Item	System configuration	
	Usage	Model
Power supply module	—	
CPU	—	
Serial communication module Computer link module	Used, Not used	
Network module	Used, Not used	
Interrupt module	Used, Not used	
Positioning module	Used, Not used	
Number of PLC extension base units	—	extension base units
When using any other units or others, describe them.		

Entry column for recurrence (when the malfunction has occurred after the corrective action was taken)

Describe the operational situation when the GOT screen froze or if the GOT display was faulty upon recurrence.

32

Error messages and system alarms

Page 138 Displayed contents

Page 141 Error messages and system alarms

This section explains the error messages and system alarms displayed on the GOT.

The system alarm function displays the error code and error message when an error occurs in the GOT, controller, or network.

For details on the system alarm, refer to the following.

GT Designer3 (GOT3000) Screen Design Manual

Point

You can check error codes in the error code storage area for the system information function.

The channel number where an error has occurred can be checked with the GOT special registers (GS262 to GS264).

For details on the system information and GOT special registers, refer to the following.

GT Designer3 (GOT3000) Screen Design Manual

32.1 Displayed contents

The section explains an example of displaying an error code and error message on the GOT.

32.1.1 Popup display (alarm popup display)

When an error occurs, the GOT can display the error code and error message with the popup display at the front of the monitor screen.

Since an alarm pops up regardless of the screen, you cannot miss the error.



Generated alarms appear as pop-ups regardless of the screen.

32.1.2 List display (system alarm display)

When an error occurs, the GOT can display the error codes and error messages in the list set on the screen.

Displaying multiple errors and recording the events as history are available.

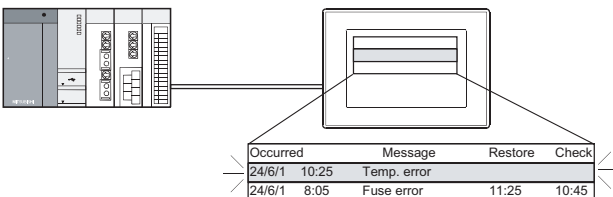

Create a screen that display alarms, and check and address the alarm details.





32.1.3



Checking error messages with the utility (Utility)

You can check the error codes and error messages using the system alarm display of the utility even though its object is not set.

 GOT3000 Series User's Manual (Utility & Maintenance Functions)

The following shows the error codes and the reference manuals.

Error source	Error code	Description	Storage location of channel No. with error ^{*1}	Reference
Controller	0 to 99 (Value of D9008)	Error code of CPU (ACPU)	GS263	User's Manual of the ACPUs connected to the GOT
	100 to 299	Error code of the following controllers • FXCPU ^{*2} • Non-Mitsubishi Electric PLC		Manual of the controller connected to the GOT Deal with errors according to the error messages.
GOT ^{*3}	300 to 399	Error code of the GOT main unit function	GS262 ^{*4}	 GOT3000 Series User's Manual (Utility & Maintenance Functions)
	400 to 499	Error code of the GOT communication function		
	500 to 699	Error code of the GOT main unit function		
Network	800 to 999	Error code of the network	GS264	 GOT3000 Series User's Manual (Utility & Maintenance Functions)
CPU	1000 to 10000 (Value of SD0)	Error code of the CPU (QCPU, LCPU)	GS263	User's manual of the QCPU or LCPU connected to the GOT
		Error code of an RCPUs or Motion CPU (MELSEC iQ-R series)		A system alarm message appears to indicate the code of the error occurring in an RCPUs. For the displayed contents of the system alarms, refer to the following.  GOT3000 Series User's Manual (Utility & Maintenance Functions) For error handling, check the manual of the RCPUs.
		Error code of an FX5CPU		A system alarm message appears to indicate the code of the error occurring in an FX5CPU. For the displayed contents of the system alarms, refer to the following.  GOT3000 Series User's Manual (Utility & Maintenance Functions) For error handling, check the manual of the FX5CPU.
Motion CPU	10001 to 10999	Error code of a Motion CPU (Q173D(S)CPU/Q172D(S)CPU/Q170M(S)CPU)	GS263	^{*5}
CNC C70	11000 to 11999	Error code of the CNC (Q173NCCPU)	GS263	^{*6}
Robot controller	12000 to 12999	Error code of the robot controller	GS263	^{*7}
CPU	15000 to 15999	Error code of an RCPUs	GS263	^{*8}
	16000	Error code of an FX5CPU		^{*9}
Servo amplifier ^{*10}	20016 to 21121	Error code of the servo amplifier	GS263	User's Manual of the servo amplifier connected to the GOT

- *1 For details on the GOT special registers (GS262 to GS264), refer to the following.
 GT Designer3 (GOT3000) Screen Design Manual
- *2 FXCPU has error codes 100 to 109, indicating the status of M8060 to M8069.
 (Example) If error code (100) occurs, handle the error according to the M8060 description.
- *3 With the system alarm related to the file access, you cannot identify the drive where the alarm occurs. However, you can identify the drive by checking the File Access Error signal (b7 to b10) of System signal 2-2.
- *4 Depending on the error code, the channel number is not stored.
 For channel number storage availability of each error code, refer to the following.
 GT Designer3 (GOT3000) Screen Design Manual
- *5 The GOT displays the error code corresponding to an error occurring in the multiple CPU system.
 Check the error details with MT Developer or MT Works2.
 For error handling, refer to the manual of the Motion CPU.
- *6 The GOT displays the error code corresponding to an error occurring in the multiple CPU system.
 Check the error details with the CNC monitor.
 For error handling, refer to the manual of the CNC.
- *7 The GOT displays the error code corresponding to an error occurring in a robot controller in the multiple CPU system or a standalone robot controller.
 Check the error details with RT ToolBox2 or RT ToolBox3.
 For error handling, refer to the manual of the robot controller.
- *8 The GOT displays the error code corresponding to an error occurring in an RCPU or Motion CPU (MELSEC iQ-R series).
 Check the error details with GX Works3 or MT Works2.
 For error handling, refer to the manual of the RCPU or Motion CPU (MELSEC iQ-R series).
- *9 The GOT displays the error code corresponding to an error occurring in an FX5CPU.
 Check the error details with GX Works3.
 For error handling, refer to the manual of the FX5CPU.
- *10 The GOT displays the error code displayed on the servo amplifier (hexadecimal) in decimal + 20000.
 Therefore, when referring to the manual of the servo amplifier with the error code displayed on the GOT using the system alarm, subtract 20000 from the GOT error code and convert the last 3 digits into the hexadecimal number.
 (Example: When the GOT system alarm is 20144, the error code of the servo amplifier is 90H.)

32.2 Error messages and system alarms

For details on the error messages and the system alarms displayed on the GOT, refer to the following.

 GOT3000 Series User's Manual (Utility & Maintenance Functions)

PART 10

EMC Directive and Low Voltage Directive

33 Overview

34 EMC Directive Requirements

35 Low Voltage Directive requirements

Regulatory standards are established in all countries for electromagnetic compatibility (EMC) and electrical safety. For products sold in Europe, conformance to the EMC Directive, which is one of the European Directives, has been a mandatory requirement of the EMC standards since 1996.

In addition, conformance to the Low Voltage Directive, another European Directive, has also been mandatory as the electrical safety standards since 1997.

In Europe, if a product meets the requirements of the EMC Directive or the Low Voltage Directive, the product's manufacturer must declare conformity of the product and affix the CE mark to the product.

This section describes the EMC Directive and Low Voltage Directive as examples for conformance to EMC and electrical safety standards. EMC and electrical safety standards in each country are stipulated to be consistent with the corresponding international standards. When the requirements are consistent with the same standards, common measures are taken to conform to the standards in different countries.

Authorized representative in the EU

The authorized representative in the EU is shown below.

Company: Mitsubishi Electric Europe BV

Address: Mitsubishi-Electric-Platz 1, 40882 Ratingen, Germany

33.1 Conforming standards in the EMC Directive

The GOT complies with the following standards in the EMC Directive.

Applied standard	Test standard	Test details	Standard value
EN61131-2: 2007	CISPR16-2-3 Radiated noise ^{*1*2}	Test for measuring electromagnetic emissions from the product	<ul style="list-style-type: none"> • 30 MHz to 230 MHz QP: 30 dBμV/m (measured at 30 m)^{*3*4} • 230 MHz to 1000 MHz QP: 37 dBμV/m (measured at 30 m)^{*3*4}
	CISPR16-2-1 Conducted noise ^{*1*2}	Test for measuring electromagnetic emissions from the product to the power cables	<ul style="list-style-type: none"> • 150kHz to 500kHz QP: 79 dB, Mean: 66 dB^{*3} • 500kHz to 30MHz QP: 73 dB, Mean: 60 dB^{*3}
	IEC61000-4-2 Electrostatic immunity ^{*1*2}	Immunity test in which static electricity is applied to the cabinet of the equipment	<ul style="list-style-type: none"> • Contact discharge: \pm4 kV • Aerial discharge: \pm8 kV
	IEC61000-4-3 Amplitude-modulated radiated electromagnetic field ^{*1*2}	Immunity test in which an electric field is applied to the product	80 MHz to 1000 MHz: 10 V/m 1.4 GHz to 2 GHz: 3 V/m 2.0 GHz to 2.7 GHz: 1 V/m (80% amplitude modulation at 1 kHz)
	IEC61000-4-4 Fast transient burst noise ^{*1*2}	Immunity test in which burst noise is applied to the power cables and the signal lines	Power cable: 2 kV Digital I/O: 1 kV Analog I/O: 1 kV Signal cable: 1 kV
	IEC61000-4-5 Surge immunity ^{*1*2}	Immunity test in which lightning surge is applied to the product	<ul style="list-style-type: none"> • AC power type Power cable (between cable and ground): \pm2 kV Power cable (between cables): \pm1 kV Data communication port: \pm1 kV • DC power type Power cable (between cable and ground): \pm0.5 kV Power cable (between cables): \pm0.5 kV Data communication port: \pm1 kV
	IEC61000-4-6 Conducted RF immunity ^{*1*2}	Immunity test in which a noise inducted on the power cable and the signal lines is applied	Power cable: 10 V Data communication port: 10 V
	IEC61000-4-8 Power supply frequency magnetic field immunity ^{*1*2}	Test for checking normal operation when exposed to the strong magnetic field noise at the power supply frequency (50/60 Hz)	30 A/m
	IEC61000-4-11 Instantaneous power failure and voltage dip immunity	Test for checking normal operation during instantaneous power failure	<ul style="list-style-type: none"> • AC power type 0.5 cycle 0% (1 to 10 second intervals) 250/300 cycle 0% 10/12 cycle 40% 25/30 cycle 70%

*1 The GOT is an open type device (designed to be integrated in equipment).

Make sure to install the GOT in a control panel.

This test item is conducted in the condition where the GOT is installed on a control panel and combined with the MITSUBISHI ELECTRIC PLC.

*2 The length of a sound output cable must be 30 m or less.

*3 QP: Quasi-peak value, Mean: Average value

*4 This test item is conducted in the following conditions.

30 MHz to 230 MHz

QP: 40 dB μ V/m (measured at 10 m)

230 MHz to 1000 MHz

QP: 47 dB μ V/m (measured at 10 m)

33.2 Conforming standards in the Low Voltage Directive

The GOT complies with the following standards in the Low Voltage Directive.

- EN 61010-1: Safety requirements for electrical equipment for measurement, control, and laboratory use - Part 1: General requirements
- EN IEC 61010-2-201: Safety requirements for electrical equipment for measurement, control, and laboratory use - Part 2-201: Particular requirements for control equipment

34 EMC Directive Requirements

The EMC Directive requires the following:

- Strong electromagnetic waves are not emitted externally. Emission: Electromagnetic interference
- The product is not affected by external electromagnetic waves. Immunity: Electromagnetic sensitivity

To comply with the EMC Directive, this chapter explains the precautions for configuring equipment incorporating the GOT.

The information provided herein is produced to the best of our ability based on the regulation requirements and standards that we have obtained. However, this does not guarantee that all equipment produced in accordance with the information complies with the above directive.

The manufacturer of the equipment must determine the method to comply with the EMC Directive and ensure conformity to the directive.

34.1 Installing the GOT on the control panel

The GOT is an open type device (designed to be integrated in equipment).

Make sure to install the GOT in a control panel.

This restriction ensures safety and also has a large effect of suppressing noise generated from the GOT by using the control panel.

34.1.1 Control panel

The control panel must be conductive.

When fixing a top or bottom plate of the control panel with bolts, do not coat the plate and bolt surfaces so that they contact each other.

Connect the door and the box using a thick grounding cable to ensure low impedance under high frequency.

To ensure electric conductivity in as large an area as possible between the inner plate and the control panel, do not paint the installation bolt area.

Ground the control panel using a thick grounding cable to ensure the low impedance under high frequency.

The diameter of cable holes on the control panel must be 10 cm or less.

If the diameter of the hole is 10 cm or more, radio waves may leak.

To reduce the chance of radio waves leaking out, ensure that the space between the control panel and its door is as small as possible.

Pasting the following EMI gasket directly on the painted surface seals the space, reducing the leak of electric waves.

Manufacturer	Model
NITTO KOGYO CORPORATION	UC-300279ES

Our test has been carried out on a panel having the damping characteristics of 48 dB max. and 28 dB mean (measured using the 3 m method at 30 MHz to 300 MHz).

34.1.2 Connection of power and ground cables

Ground the GOT and connect power supply cables as shown below.

Wiring the ground cable

Provide a ground point near the GOT. Short-circuit the line ground terminal (LG terminal) and the frame ground terminal (FG terminal) of the GOT, and ground them with the thickest and shortest cable as possible.

Ground cable length

The ground cable length must be 30 cm or shorter.

The LG and FG terminals pass the noise generated in the GOT system to the ground.

Therefore, ensure an impedance as low as possible.

Since the ground cables relieve the noise, the cables themselves carry a large noise.

Thus, short wiring prevents the cable from acting as an antenna.

(A long conductor is an antenna radiating noise more efficiently.)

Treatment of the power cable and the ground cable

Twist the ground cable led from the ground point with the power cable.

Twisting with the ground cable relieves more noise from the power cable to the ground.

When a noise filter is installed to the power cable, twisting the power cable and the ground cable may not be required.

34.2 Installing a noise filter (power supply line filter)

A noise filter is a part to effectively reduce conducted noise.

Although installing a noise filter on the power supply line is not mandatory, doing so can suppress a larger amount of noise.

The noise filter is effective to reduce conducted noise in the band of 10 MHz or less.

Use a noise filter equivalent on the following models.

Model	Manufacturer	Rated current	Rated voltage
FR-S5NFSA-1.5K	Mitsubishi Electric Corporation	25 A	240 V
RSHN-2006	TDK Corporation	6A	250V

Precautions

The following shows the precautions for installing a noise filter.

■ Prohibition of bundling cables

Do not bundle the input and output cables of the noise filter together.

Bundling the cables induces the noise from the output-side cable into the input-side cable where noise has been eliminated by the noise filter.

Wire the input and output cables separately.

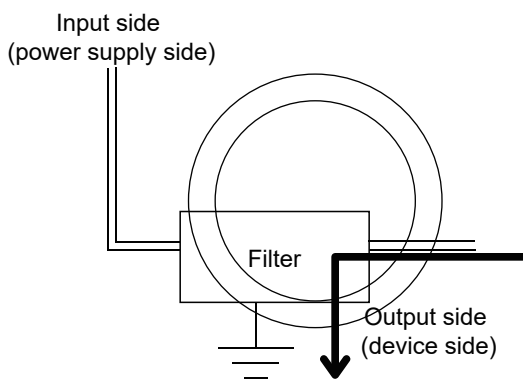

Bundling the input and output cables together induces noise.

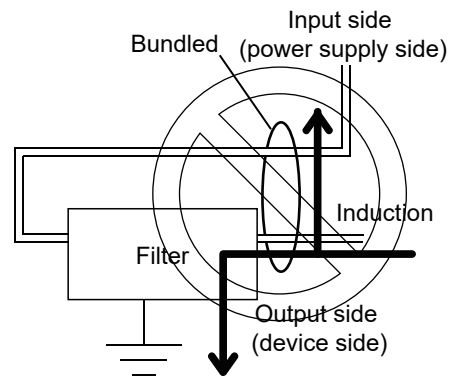

■ Grounding the noise filter

Connect the ground terminal of the noise filter to the control panel with a short cable as much as possible (approximately 10 cm).

34.3 System configuration

You can also check the EMC Directive compliance status of the GOT3000 series on the Mitsubishi Electric Factory Automation Global Website.

For the latest information, go to the Mitsubishi Electric Factory Automation Global Website.

www.MitsubishiElectric.com/fa

☞ Page 149 GOT

☞ Page 150 Connection type

☞ Page 151 Communication unit

☞ Page 152 Cable

34.3.1 GOT

Use the following GOTs having a CE mark on the rating plate.

For how to check the hardware version of the GOT, refer to the following.

☞ Page 171 Confirmation of versions and conforming standards

○: EMC compliant —: Not EMC compliant

Product	Model	Hardware version (Manufacture year and month)	EMC Directive
GT3715	GT3715-FHCBD	Version A or later (March 2025)	○
GT3715	GT3715-XRBA	Version A or later (December 2025)	○
	GT3715-XRBD		
GT3712	GT3712-WXCBD	Version A or later (March 2025)	○
GT3712	GT3712-XRBA	Version A or later (March 2025)	○
	GT3712-XRBD		
GT3710	GT3710-XRBA	Version A or later (March 2025)	○
	GT3710-XRBD		
GT3708	GT3708-XRBA	Version A or later (March 2025)	○
	GT3708-XRBD		

34.3.2 Connection type

The following table lists the connection types compliant with the EMC Directive.

○: EMC compliant —: Not EMC compliant

Connection type ^{*1}	GT37
Ethernet connection	○
Serial communication connection	○
CC-Link IE TSN connection	○
CC-Link IE Controller Network connection	○
CC-Link IE Field Network connection	○
CC-Link connection (intelligent device station)	○
GOT multi-drop connection	○
Bus connection	○
MELSECNET/H connection	○
Other than the above (connections with non-Mitsubishi Electric PLCs, microcomputers, inverters, temperature controllers, servo amplifiers, CNCs, and MODBUS equipment, etc.) ^{*2}	○

*1 For details on each connection type, refer to the following manual.

 GOT3000 Series User's Manual (Connection)

*2 When connecting the GOT to other devices such as a non-Mitsubishi Electric PLCs, create the cable and configure the system according to the EMC Directive specifications of the devices.

 Page 158 Connection cable for non-Mitsubishi Electric PLCs, microcomputers, temperature controllers, inverters, servo amplifiers, CNCs, and MODBUS/RTU or MODBUS/TCP equipment

Precautions

When the GOT is connected to a non-Mitsubishi Electric PLC, configure the system according to the EMC Directive specifications for the controller.

For information on conformity with the EMC Directive, refer to the manual of the controller.

34.3.3 Communication unit

To comply with the EMC Directive, use the following communication units.

When any other than the following communication units is used, the GOT does not comply with the EMC Directive.

Connection type	Communication unit	Hardware version (Manufacture year and month)
Ethernet connection	Built-in Ethernet interface of the GOT	—
Serial communication connection	Built-in RS-232/422/485 interface of the GOT	—
	GT15-RS2-9P GT15-RS4-9S GT15-RS4-TE	Version D or later (January 2006)
CC-Link IE TSN connection	Built-in Ethernet interface of the GOT	—
	GT25-J71GN13-T2	Version A or later (June 2019)
CC-Link IE Controller Network connection	GT15-J71GP23-SX	Version A or later (December 2007)
CC-Link IE Field Network connection	GT15-J71GF13-T2	Version A or later (April 2011)
CC-Link connection (intelligent device station)	GT15-J61BT13	Version C or later (September 2006)
Bus connection	GT15-QBUS	Version D or later (October 2005)
	GT15-QBUS2	Version C or later (October 2005)
	GT15-75QBUSL GT15-75QBUS2L	Version G or later (March 2005)
MELSECNET/H connection (PLC to PLC network)	GT15-J71LP23-25 GT15-J71BR13	Version C or later (September 2006)
Non-Mitsubishi Electric PLC connection	Built-in RS-232/422/485 interface of the GOT	—
	GT15-RS2-9P GT15-RS4-9S	Version D or later (January 2006)
Microcomputer connection (Ethernet)	Built-in Ethernet interface of the GOT	—
Microcomputer connection (serial)	Built-in RS-232/422/485 interface of the GOT	—
	GT15-RS2-9P GT15-RS4-9S	Version D or later (January 2006)
Temperature controller connection	Built-in RS-232/422/485 interface of the GOT	—
	GT15-RS2-9P GT15-RS4-9S GT15-RS4-TE	Version D or later (January 2006)
Inverter connection	Built-in RS-422/485 interface of the GOT	—
	GT15-RS4-9S	Version D or later (January 2006)
Servo amplifier connection	Built-in RS-232/422/485 interface of the GOT	—
	GT15-RS2-9P GT15-RS4-9S	Version D or later (January 2006)
CNC connection	Built-in RS-232/422/485 interface of the GOT	—
	GT15-RS2-9P GT15-RS4-9S	Version D or later (January 2006)
	GT15-J71LP23-25 GT15-J61BT13	Version C or later (September 2006)
	Built-in Ethernet interface of the GOT	—
MODBUS/RTU connection	Built-in RS-232/422/485 interface of the GOT	—
	GT15-RS2-9P GT15-RS4-9S GT15-RS4-TE	Version D or later (January 2006)
MODBUS/TCP connection	Built-in Ethernet interface of the GOT	—

34.3.4 Option unit

To comply with the EMC Directive, use one of the following option units.

If any option unit other than those listed below is used, the GOT will not comply with the EMC Directive.

Product name	Model	Hardware version (Manufacture year and month)
External I/O unit	GT15-DIO	Version B or later (May 2007)
	GT15-DIOR	Version A or later (July 2008)

34.3.5 Cable

CC-Link IE Field Network connection

Use the following cable dedicated to the CC-Link IE Field Network.

Manufacturer	Model
Mitsubishi Electric System & Service Co., Ltd.	SC-E5EW-S□M

MELSECNET/H connection (coaxial cable)

Use a double shielded coaxial cable.

The 5C-2V connector plug can be used with the double shielded coaxial cable.

Connect the 5C-2V connector plug to the coaxial cable inside the double shielded coaxial cable.

Ground the shielded part outside the double shielded coaxial cable as shown in the following figure.

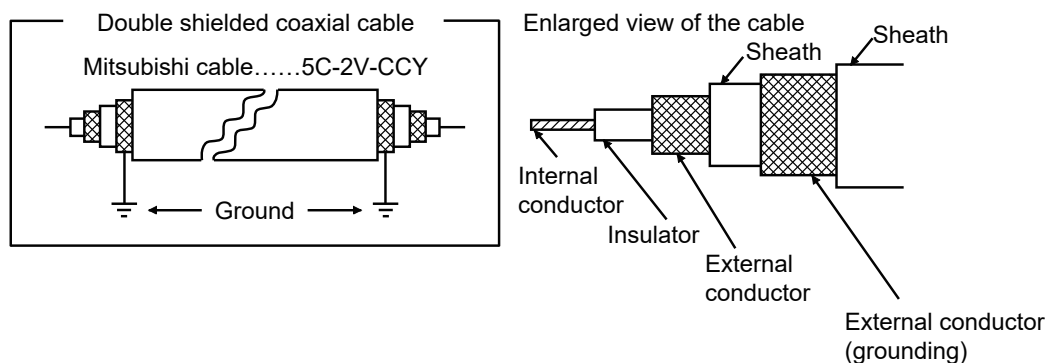

Other connections

For the details of the cables used, refer to the following manual.

GOT3000 Series User's Manual (Connection)

Point

To comply with the EMC Directive, fabricate cables (including user-created cables).

For how to fabricate a cable, refer to the following.

GOT3000 Series User's Manual (Connection)

34.4 Connection of power cables and ground cables

Carry out wiring and connect the power and ground cables according to the following instruction.
By the different wiring or connection method, the system may not comply with EMC Directive.

34.4.1 Wiring method

As shown in the figure below, connect the power cable and the ground cable, and then attach a ferrite core (ZCAT3035-1330, manufactured by TDK Corporation) within the specified range.

Make sure to ground the FG cable and LG cable.

For connection of power cables and ground cables, refer to the following.

☞ Page 147 Connection of power and ground cables

Power supply section of the GOT with a 100 V AC to 240 V AC power source

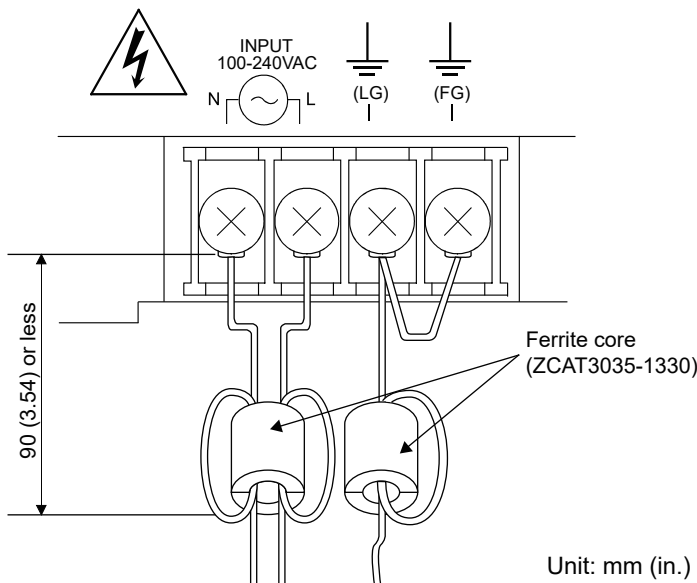

Power supply section of the GOT with a 24 V DC power source

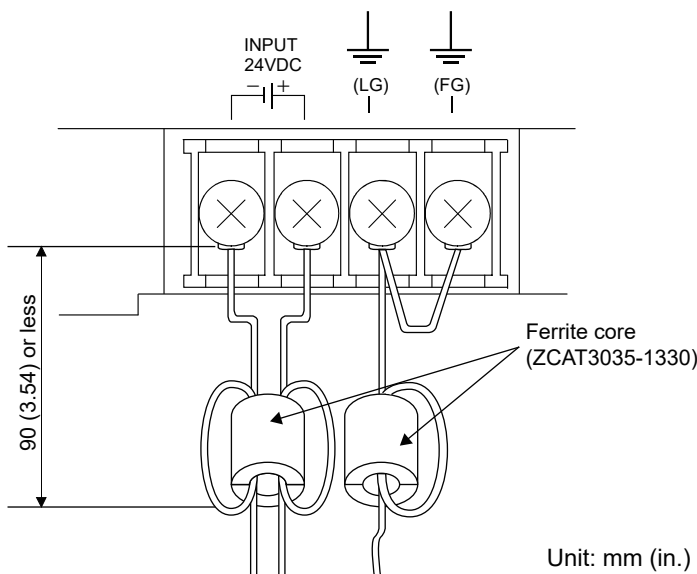

34.5 Fabricating a connection cable

Fabricate the cables used for the GOT using the methods shown in this section.

Ferrite cores and a cable clamp are required for fabrication.

The following products have passed the Mitsubishi Electric EMC Directive compliance test.

Product	Manufacturer	Model
Ferrite core	TDK Corporation	ZCAT3035-1330
Cable clamp	Mitsubishi Electric Corporation	AD75CK

34.5.1 Ethernet cable

Strip off the sheath at both ends of the cable as shown in the figure below to expose the braided shield for grounding.

The braided shield sections are used for grounding with a cable clamp.

☞ Page 159 Grounding a cable

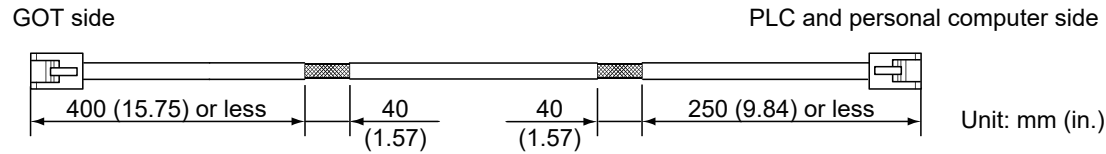

34.5.2 Serial communication connection cable

RS-422/485 cable

Strip off the sheath at both ends of the cable as shown in the figure below to expose the braided shield for grounding.

The braided shield sections are used for grounding with a cable clamp.

☞ Page 159 Grounding a cable

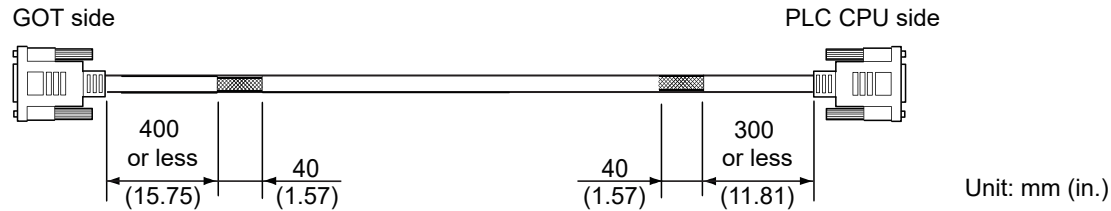

RS-232 cable

Strip off the sheath at both ends of the cable as shown in the figure below to expose the braided shield for grounding.

The braided shield sections are used for grounding with a cable clamp.

☞ Page 159 Grounding a cable

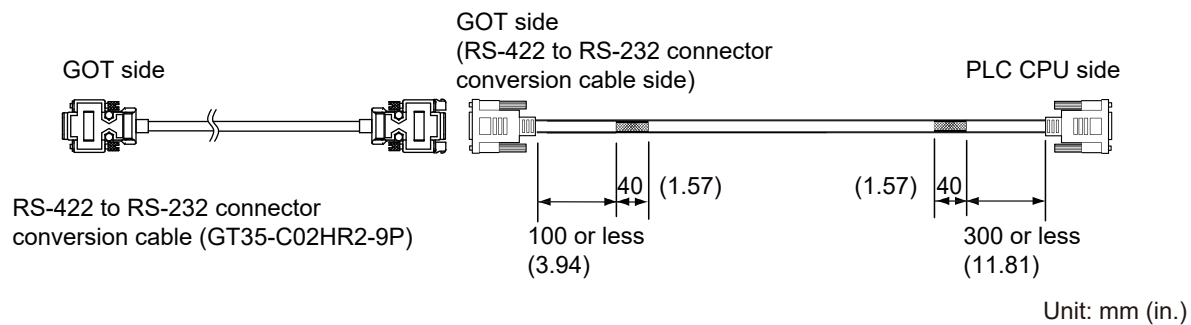

34.5.3 CC-Link IE TSN cable

Strip off the sheath at both ends of the cable as shown in the figure below to expose the braided shield for grounding. The braided shield sections are used for grounding with a cable clamp.

☞ Page 159 Grounding a cable

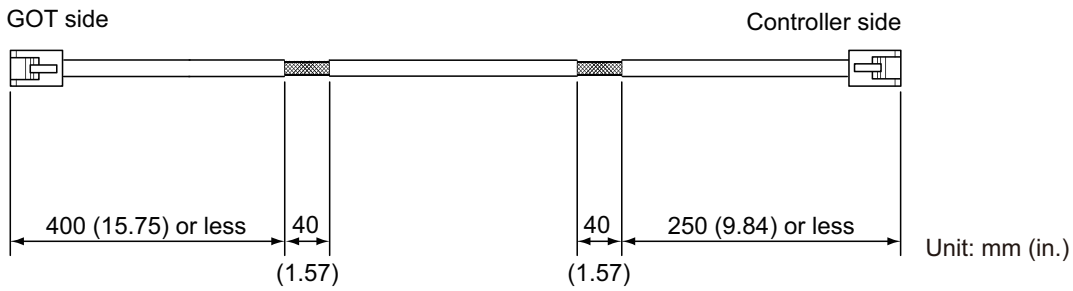

34.5.4 CC-Link IE Field Network cable

Strip off the sheath at both ends of the cable as shown in the figure below to expose the braided shield for grounding. The braided shield sections are used for grounding with a cable clamp.

☞ Page 159 Grounding a cable

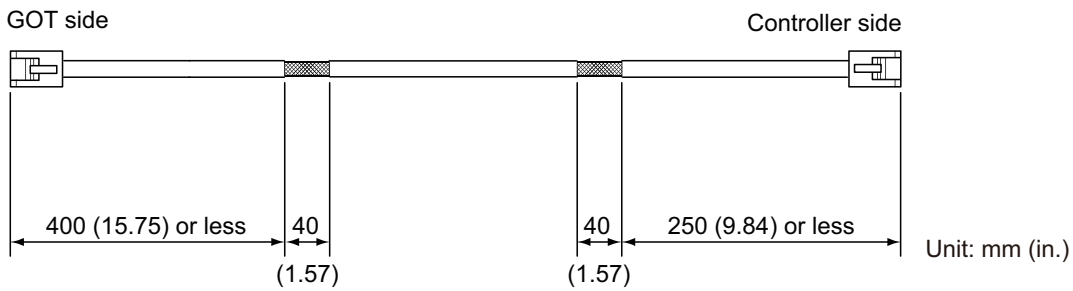

34.5.5

CC-Link connection (intelligent device station) cable

1. Strip off the sheath at both ends of the cable as shown in the figure below to expose the braided shield for grounding. The braided shield sections are used for grounding with a cable clamp.

☞ Page 159 Grounding a cable

2. Install ferrite cores at the positions on the cable as shown in the figure below.

- CC-Link dedicated cable for GOT-to-PLC connection

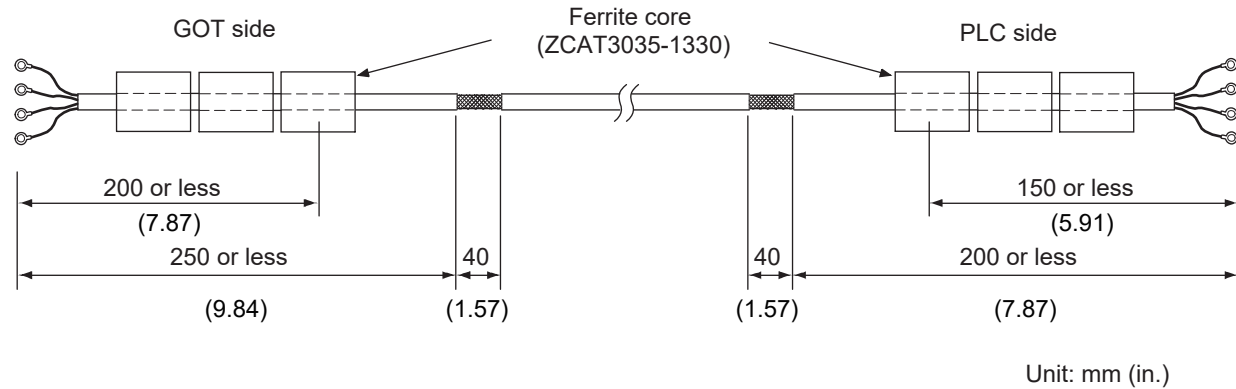

- CC-Link dedicated cable for GOT-to-GOT connection

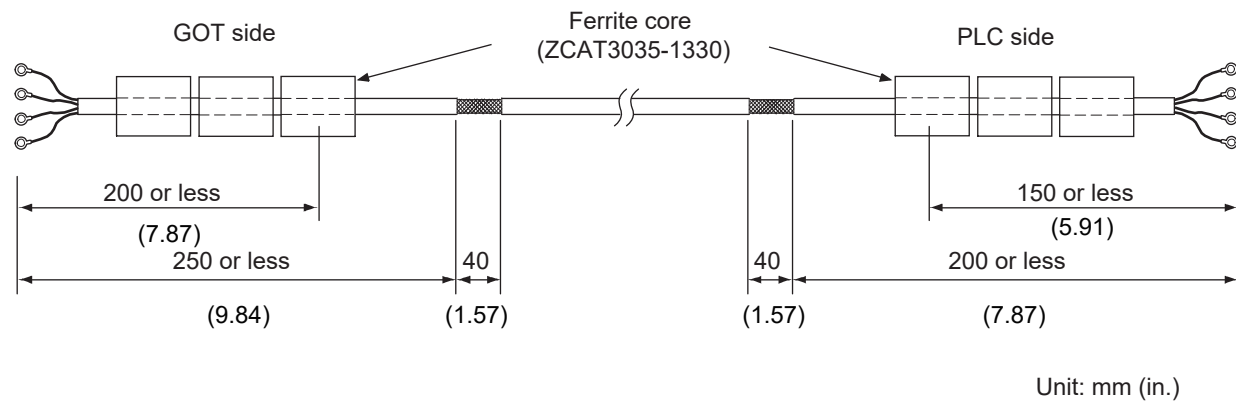

34.5.6

Bus connection cable

GT15-QC□B, GT15-QC□BS

Strip off the sheath at both ends of the cable as shown in the figure below to expose the braided shield for grounding. The braided shield sections are used for grounding with a cable clamp.

☞ Page 159 Grounding a cable

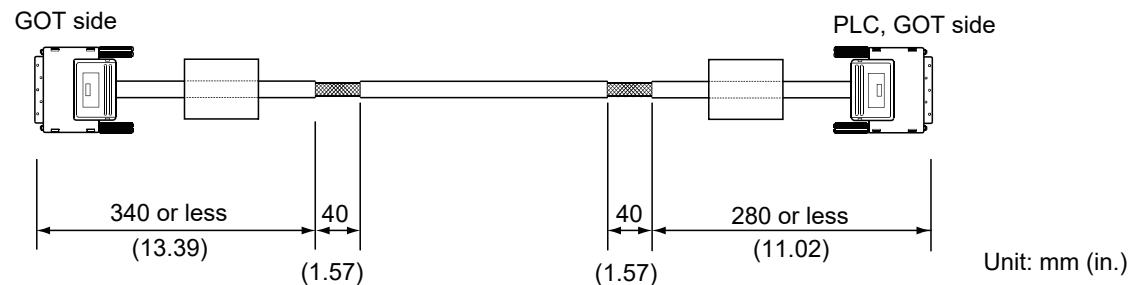

34.5.7 MELSECNET/H connection cable (PLC-to-PLC network)

• Coaxial cable

1. Strip off the sheath at both ends of the cable as shown in the figure below to expose the braided shield for grounding. The braided shield sections are used for grounding with a cable clamp.

☞ Page 159 Grounding a cable

2. Install ferrite cores at the positions on the cable as shown in the figure below.

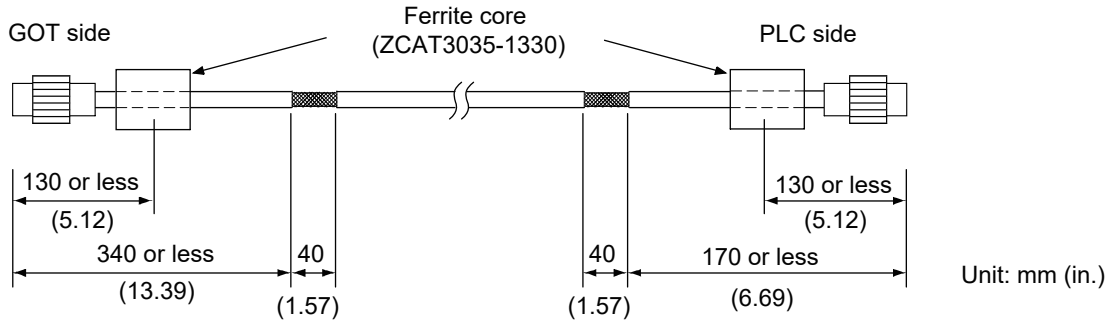

• Fiber optic cable

No cable fabrication is required.

34.5.8 External I/O device connection cable

1. Strip off the sheath at both ends of the cable as shown in the figure below to expose the braided shield for grounding. The braided shield sections are used for grounding with a cable clamp.

☞ Page 159 Grounding a cable

2. Connect the braided shield to the connector cover.

3. Twist the power cable.

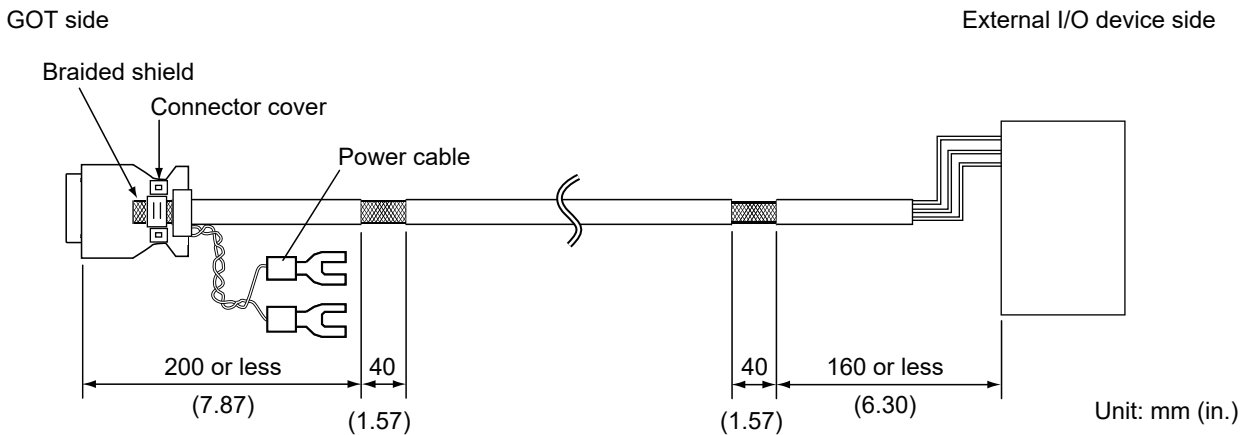

34.5.9 HDMI cable

Install ferrite cores at the positions on the cable as shown in the figure below.

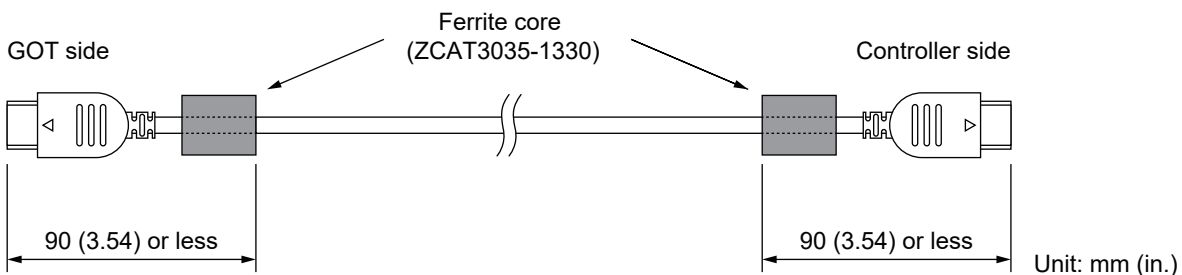

34.5.10

Connection cable for non-Mitsubishi Electric PLCs, microcomputers, temperature controllers, inverters, servo amplifiers, CNCs, and MODBUS/RTU or MODBUS/TCP equipment

Create the cables (RS-232 cable, RS-422/485 cable) for connecting the GOT and a controller by yourself.

For how to create a cable, refer to the following.

📖 GOT3000 Series User's Manual (Connection)

Treatment of the RS-232 cable and RS-422/485 cable

When the GOT is connected to a controller, configure the system according to the EMC Directive specifications for the controller.

The following shows the recommended instructions to comply with the EMC Directive.

However, the manufacturer of the equipment must determine the method to comply with the EMC Directive and ensure conformity to the directive.

■RS-422/485 cable

When connecting each signal wire (except SG and FG wires), twist two signal wires as shown below.

Connect two or more SG wires.

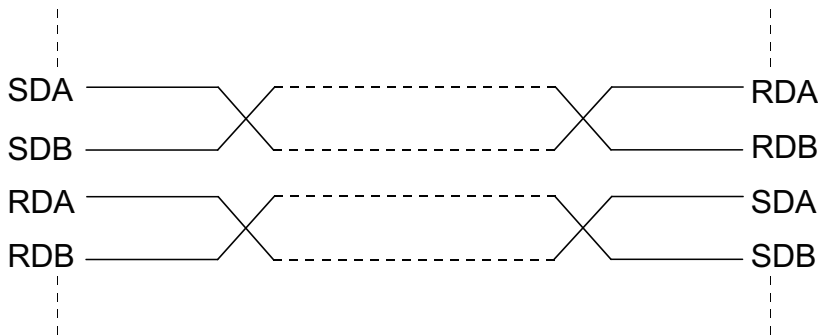

■RS-232 cable

Twist each signal wire (except SG and FG wires) with the SG wire.

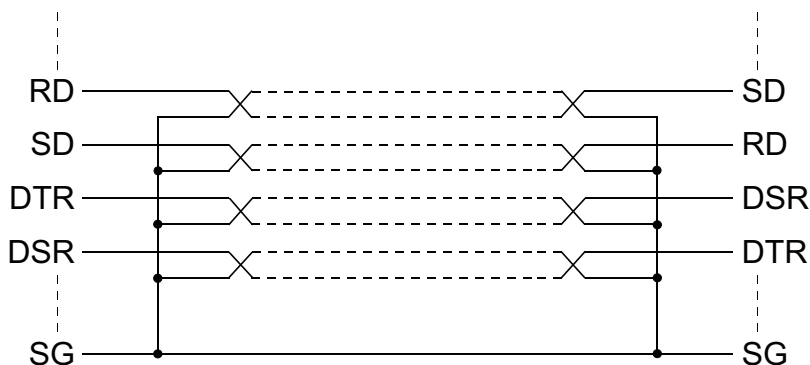

34.6 Grounding a cable

34.6.1 Grounding method

Ground the cable and ground cable to the control panel where the GOT and the PLC are installed.
Ground the braided shield section of the cable to the control panel with the cable clamp (AD75CK).

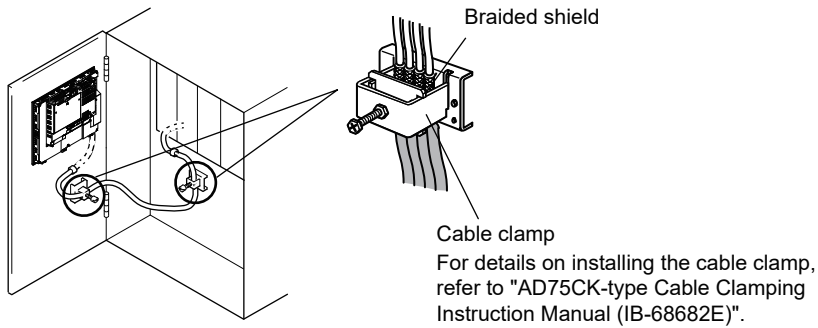

Precautions

Do not arrange the cable clamp close to the other cables that are not clamped.
The noise from the control panel may enter the cable clamp and adversely affect the GOT.

35

Low Voltage Directive requirements

The Low Voltage Directive requires that the equipment operating with power supply ranging from 50 V AC to 1000 V AC or 75 V DC to 1500 V DC has enough safety.

This chapter explains the precautions for the installation and wiring of the GOT to comply with the Low Voltage Directive.

The data described herein are produced with our best, based on the regulation requirements and standards obtained by Mitsubishi Electric. However, the data do not guarantee that the equipment produced according to the data comply with the above directive.

The manufacturer of the equipment must determine the method to comply with the Low Voltage Directive and conformance to the directive.

35.1 Power supply

The insulation specification of the GOT is designed assuming installation category II.

Make sure to supply power to the GOT in installation category II.

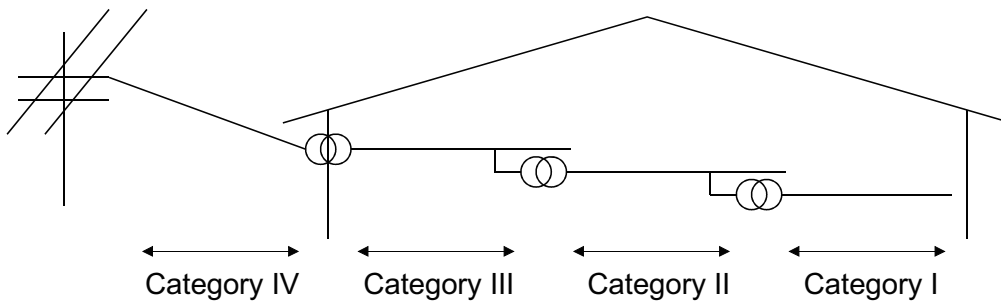

The installation category indicates the withstand surge voltage generated by lightning strike. Installation category I indicates the lowest withstand level, and installation category IV indicates the highest withstand level.

Installation category II indicates a power supply whose voltage has been reduced by two or more levels of isolation transformers from the public power distribution.

35.2 Control panel

The GOT is an open type device (designed to be integrated in equipment).
Make sure to install the GOT in a control panel.

35.2.1 Electric shock protection

To prevent a person who does not have enough knowledge of electric facilities, such as an operator, from electric shock, take the following measures on the control panel.

Locking the control panel

Lock the control panel, and allow only a person who is well educated and has enough knowledge of electric facilities to unlock the control panel.

Automatic power shutdown

Build the structure so that the power supply shuts down when the control panel is opened.

35.2.2 Dustproof and waterproof features

The control panel also prevents dust and water.

Insufficient dustproof and waterproof protection may lower the insulation withstand voltage, resulting in insulation breakdown. Since the insulation of the GOT is designed assuming pollution degree 2, use the GOT in an environment of pollution degree 2 or less.

Pollution degree	Description
1	Environment where the air is dry and nonconductive dust occurs
2	Environment where normally nonconductive dust occurs However, temporary conductivity occasionally occurs due to the accumulated dust. For example, the inside of the control panel in a control room or on the floor at a typical factory.
3	Environment where conductive dust occurs and conductivity may occur due to the accumulated dust For example, a typical factory floor
4	Environments where continuous conductivity may occur due to rain, snow, etc. Outdoor for example.

35.3 Grounding

The ground terminals must be grounded in use.

Ground the GOT to ensure the safety and to comply with the EMC Directive.

The GOT has the following ground terminals:

Functional grounding \perp : The functional ground terminal improves noise resistance.

35.4 External wiring

35.4.1 External controllers

If an external device connected to the GOT has a hazardous voltage circuit, the interface circuit to the GOT must have a reinforced insulation.

35.4.2 Reinforced insulation

The reinforced insulation indicates the insulation with the following withstand voltage.

Reinforced insulation withstand voltage (Source: Installation Category II of IEC60664-1)

Rated voltage of hazardous voltage area	Withstand surge voltage (1.2/50 μ s)
150 V AC or less	2500 V
300 V AC or less	4000 V

Appendices

Appendix 1 Cable bend radius for GT37 with an extension unit

The following shows the cable bend radius for the GOT with an extension unit installed using the extension interface converter unit (GT37-IF2000).

☞ Page 165 GT3715-FH

☞ Page 166 GT3712-WX

☞ Page 167 GT3715-X

☞ Page 168 GT3712-X

☞ Page 169 GT3710-X

☞ Page 170 GT3708-X

Point

If the cable from the extension unit does not hang below the bottom of the GOT, dimension A is smaller than dimension B.

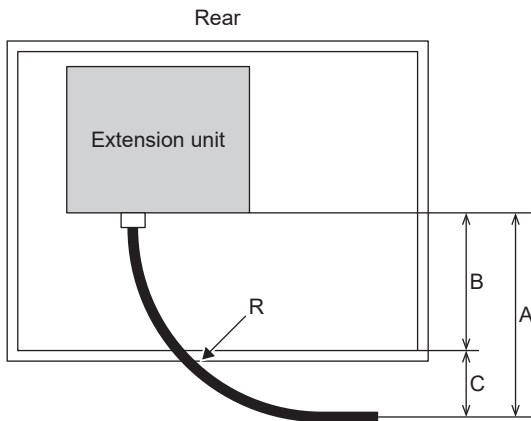

Unit: mm (in.)

Extension unit		A	B	C*1	R (cable bend radius)
Serial communication unit	GT15-RS2-9P	72.5 (2.85)	139.5 (5.49)	0	27.5 (1.08)
	GT15-RS4-9S	72.5 (2.85)	139.5 (5.49)	0	27.5 (1.08)
	GT15-RS4-TE	33.5 (1.32)	139.5 (5.49)	0	*2
CC-Link IE TSN communication unit	GT25-J71GN13-T2*3	65 (2.56)	136 (5.35)	0	26 (1.02)
CC-Link IE Controller Network communication unit	GT15-J71GP23-SX	65 (2.56)	139.5 (5.49)	0	15 (0.6)
CC-Link IE Field Network communication unit	GT15-J71GF13-T2*3	65 (2.56)	139.5 (5.49)	0	26 (1.02)
CC-Link communication unit	GT15-J61BT13	47 (1.85)	139.5 (5.49)	0	28 (1.1)
Q-bus communication unit	GT15-QBUS	88 (3.47)	139.5 (5.49)	0	50 (1.97)
	GT15-QBUS2	88 (3.47)	139.5 (5.49)	0	50 (1.97)
	GT15-75QBUSL	88 (3.47)	139.5 (5.49)	0	50 (1.97)
	GT15-75QBUS2L	88 (3.47)	139.5 (5.49)	0	50 (1.97)
MELSECNET/H communication unit	GT15-J71LP23-25	*2	139.5 (5.49)	*2	*2
	GT15-J71BR13	79 (3.11)	139.5 (5.49)	0	28 (1.1)
External I/O unit	GT15-DIO	77 (3.03)	139.5 (5.49)	0	43 (1.7)
	GT15-DIOR	77 (3.03)	139.5 (5.49)	0	43 (1.7)

*1 If the cable from the extension unit does not hang below the bottom of the GOT, the dimension is 0.

*2 For cables prepared by the user, the dimensions in the table are not applied.

*3 The bend radius depends on the Ethernet cable to be used.



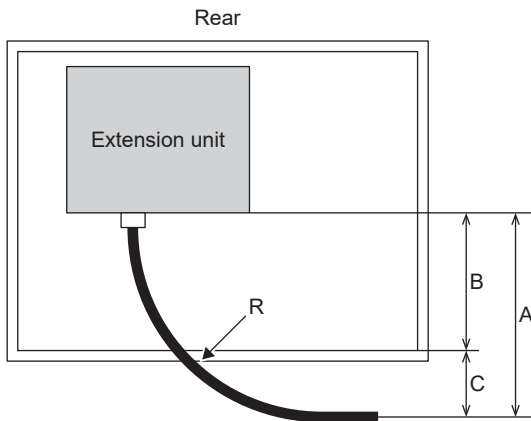

Unit: mm (in.)

Extension unit		A	B	C*1	R (cable bend radius)
Serial communication unit	GT15-RS2-9P	72.5 (2.85)	107.5 (4.23)	0	27.5 (1.08)
	GT15-RS4-9S	72.5 (2.85)	107.5 (4.23)	0	27.5 (1.08)
	GT15-RS4-TE	33.5 (1.32)	107.5 (4.23)	0	*2
CC-Link IE TSN communication unit	GT25-J71GN13-T2*3	65 (2.56)	104 (4.09)	0	26 (1.02)
CC-Link IE Controller Network communication unit	GT15-J71GP23-SX	65 (2.56)	107.5 (4.23)	0	15 (0.6)
CC-Link IE Field Network communication unit	GT15-J71GF13-T2*3	65 (2.56)	107.5 (4.23)	0	26 (1.02)
CC-Link communication unit	GT15-J61BT13	47 (1.85)	107.5 (4.23)	0	28 (1.1)
Bus connection unit	GT15-QBUS	88 (3.47)	107.5 (4.23)	0	50 (1.97)
	GT15-QBUS2	88 (3.47)	107.5 (4.23)	0	50 (1.97)
	GT15-75QBUSL	88 (3.47)	107.5 (4.23)	0	50 (1.97)
	GT15-75QBUS2L	88 (3.47)	107.5 (4.23)	0	50 (1.97)
MELSECNET/H communication unit	GT15-J71LP23-25	*2	107.5 (4.23)	*2	*2
	GT15-J71BR13	79 (3.11)	107.5 (4.23)	0	28 (1.10)
External I/O unit	GT15-DIO	77 (3.03)	107.5 (4.23)	0	43 (1.7)
	GT15-DIOR	77 (3.03)	107.5 (4.23)	0	43 (1.7)

*1 If the cable from the extension unit does not hang below the bottom of the GOT, the dimension is 0.

*2 For cables prepared by the user, the dimensions in the table are not applied.

*3 The bend radius depends on the Ethernet cable to be used.

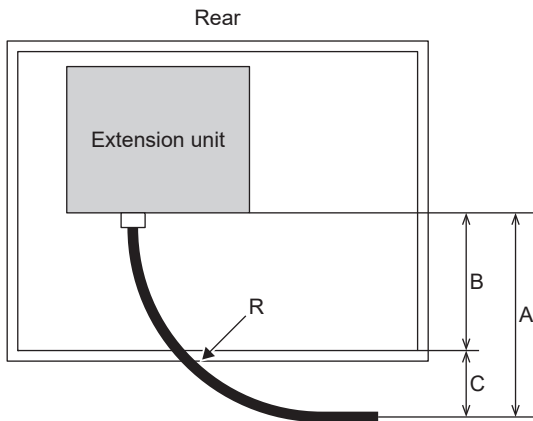

Unit: mm (in.)

Extension unit		A	B	C*1	R (cable bend radius)
Serial communication unit	GT15-RS2-9P	72.5 (2.85)	161.5 (6.36)	0	27.5 (1.08)
	GT15-RS4-9S	72.5 (2.85)	161.5 (6.36)	0	27.5 (1.08)
	GT15-RS4-TE	33.5 (1.32)	161.5 (6.36)	0	*2
CC-Link IE TSN communication unit	GT25-J71GN13-T2*3	65 (2.56)	158 (6.22)	0	26 (1.02)
CC-Link IE Controller Network communication unit	GT15-J71GP23-SX	65 (2.56)	161.5 (6.36)	0	15 (0.6)
CC-Link IE Field Network communication unit	GT15-J71GF13-T2*3	65 (2.56)	161.5 (6.36)	0	26 (1.02)
CC-Link communication unit	GT15-J61BT13	47 (1.85)	161.5 (6.36)	0	28 (1.1)
Bus connection unit	GT15-QBUS	88 (3.47)	161.5 (6.36)	0	50 (1.97)
	GT15-QBUS2	88 (3.47)	161.5 (6.36)	0	50 (1.97)
	GT15-75QBUSL	88 (3.47)	161.5 (6.36)	0	50 (1.97)
	GT15-75QBUS2L	88 (3.47)	161.5 (6.36)	0	50 (1.97)
MELSECNET/H communication unit	GT15-J71LP23-25	*2	161.5 (6.36)	*2	*2
	GT15-J71BR13	79 (3.11)	161.5 (6.36)	0	28 (1.10)
External I/O unit	GT15-DIO	77 (3.03)	161.5 (6.36)	0	43 (1.7)
	GT15-DIOR	77 (3.03)	161.5 (6.36)	0	43 (1.7)

*1 If the cable from the extension unit does not hang below the bottom of the GOT, the dimension is 0.

*2 For cables prepared by the user, the dimensions in the table are not applied.

*3 The bend radius depends on the Ethernet cable to be used.



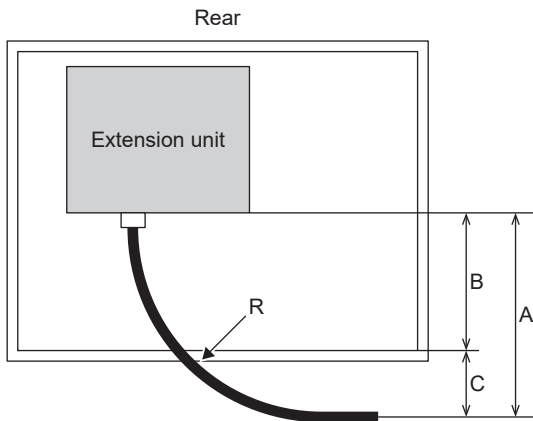

Unit: mm (in.)

Extension unit		A	B	C*1	R (cable bend radius)
Serial communication unit	GT15-RS2-9P	72.5 (2.85)	107.5 (4.23)	0	27.5 (1.08)
	GT15-RS4-9S	72.5 (2.85)	107.5 (4.23)	0	27.5 (1.08)
	GT15-RS4-TE	33.5 (1.32)	107.5 (4.23)	0	*2
CC-Link IE TSN communication unit	GT25-J71GN13-T2*3	65 (2.56)	104 (4.09)	0	26 (1.02)
CC-Link IE Controller Network communication unit	GT15-J71GP23-SX	65 (2.56)	107.5 (4.23)	0	15 (0.6)
CC-Link IE Field Network communication unit	GT15-J71GF13-T2*3	65 (2.56)	107.5 (4.23)	0	26 (1.02)
CC-Link communication unit	GT15-J61BT13	47 (1.85)	107.5 (4.23)	0	28 (1.1)
Bus connection unit	GT15-QBUS	88 (3.47)	107.5 (4.23)	0	50 (1.97)
	GT15-QBUS2	88 (3.47)	107.5 (4.23)	0	50 (1.97)
	GT15-75QBUSL	88 (3.47)	107.5 (4.23)	0	50 (1.97)
	GT15-75QBUS2L	88 (3.47)	107.5 (4.23)	0	50 (1.97)
MELSECNET/H communication unit	GT15-J71LP23-25	*2	107.5 (4.23)	*2	*2
	GT15-J71BR13	79 (3.11)	107.5 (4.23)	0	28 (1.10)
External I/O unit	GT15-DIO	77 (3.03)	107.5 (4.23)	0	43 (1.7)
	GT15-DIOR	77 (3.03)	107.5 (4.23)	0	43 (1.7)

*1 If the cable from the extension unit does not hang below the bottom of the GOT, the dimension is 0.

*2 For cables prepared by the user, the dimensions in the table are not applied.

*3 The bend radius depends on the Ethernet cable to be used.

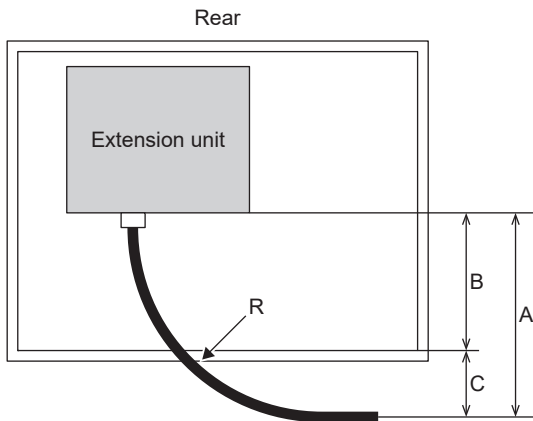

Unit: mm (in.)

Extension unit		A	B	C*1	R (cable bend radius)
Serial communication unit	GT15-RS2-9P	72.5 (2.85)	79.5 (3.13)	0	27.5 (1.08)
	GT15-RS4-9S	72.5 (2.85)	79.5 (3.13)	0	27.5 (1.08)
	GT15-RS4-TE	33.5 (1.32)	79.5 (3.13)	0	*2
CC-Link IE TSN communication unit	GT25-J71GN13-T2*3	65 (2.56)	76 (2.99)	0	26 (1.02)
CC-Link IE Controller Network communication unit	GT15-J71GP23-SX	65 (2.56)	79.5 (3.13)	0	15 (0.6)
CC-Link IE Field Network communication unit	GT15-J71GF13-T2*3	65 (2.56)	79.5 (3.13)	0	26 (1.02)
CC-Link communication unit	GT15-J61BT13	47 (1.85)	79.5 (3.13)	0	28 (1.1)
Bus connection unit	GT15-QBUS	88 (3.47)	79.5 (3.13)	0	50 (1.97)
	GT15-QBUS2	88 (3.47)	79.5 (3.13)	0	50 (1.97)
	GT15-75QBUSL	88 (3.47)	79.5 (3.13)	0	50 (1.97)
	GT15-75QBUS2L	88 (3.47)	79.5 (3.13)	0	50 (1.97)
MELSECNET/H communication unit	GT15-J71LP23-25	*2	79.5 (3.13)	*2	*2
	GT15-J71BR13	79 (3.11)	79.5 (3.13)	0	28 (1.10)
External I/O unit	GT15-DIO	77 (3.03)	79.5 (3.13)	0	43 (1.7)
	GT15-DIOR	77 (3.03)	79.5 (3.13)	0	43 (1.7)

*1 If the cable from the extension unit does not hang below the bottom of the GOT, the dimension is 0.

*2 For cables prepared by the user, the dimensions in the table are not applied.

*3 The bend radius depends on the Ethernet cable to be used.



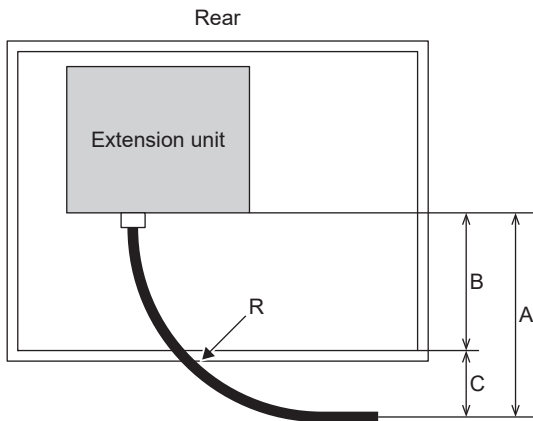

Unit: mm (in.)

Extension unit		A	B	C*1	R (cable bend radius)
Serial communication unit	GT15-RS2-9P	72.5 (2.85)	55.5 (2.19)	17 (0.67)	27.5 (1.08)
	GT15-RS4-9S	72.5 (2.85)	55.5 (2.19)	17 (0.67)	27.5 (1.08)
	GT15-RS4-TE	33.5 (1.32)	55.5 (2.19)	0	*2
CC-Link IE TSN communication unit	GT25-J71GN13-T2*3	65 (2.56)	52 (2.05)	13 (0.51)	26 (1.02)
CC-Link IE Controller Network communication unit	GT15-J71GP23-SX	65 (2.56)	55.5 (2.19)	9.5 (0.37)	15 (0.6)
CC-Link IE Field Network communication unit	GT15-J71GF13-T2*3	65 (2.56)	55.5 (2.19)	10 (0.39)	26 (1.02)
CC-Link communication unit	GT15-J61BT13	47 (1.85)	55.5 (2.19)	0	28 (1.1)
Bus connection unit	GT15-QBUS	88 (3.47)	55.5 (2.19)	32.5 (1.28)	50 (1.97)
	GT15-QBUS2	88 (3.47)	55.5 (2.19)	32.5 (1.28)	50 (1.97)
	GT15-75QBUSL	88 (3.47)	55.5 (2.19)	32.5 (1.28)	50 (1.97)
	GT15-75QBUS2L	88 (3.47)	55.5 (2.19)	32.5 (1.28)	50 (1.97)
MELSECNET/H communication unit	GT15-J71LP23-25	*2	55.5 (2.19)	*2	*2
	GT15-J71BR13	79 (3.11)	55.5 (2.19)	23.5 (0.93)	28 (1.10)
External I/O unit	GT15-DIO	77 (3.03)	55.5 (2.19)	21.4 (0.85)	43 (1.7)
	GT15-DIOR	77 (3.03)	55.5 (2.19)	21.4 (0.85)	43 (1.7)

*1 If the cable from the extension unit does not hang below the bottom of the GOT, the dimension is 0.

*2 For cables prepared by the user, the dimensions in the table are not applied.

*3 The bend radius depends on the Ethernet cable to be used.

Appendix 2 Confirmation of versions and conforming standards

Appendix 2.1 Rating plate

The GOT hardware version, BootOS version at factory default, function version, and conforming standards can be checked with the rating plate on the GOT rear face.

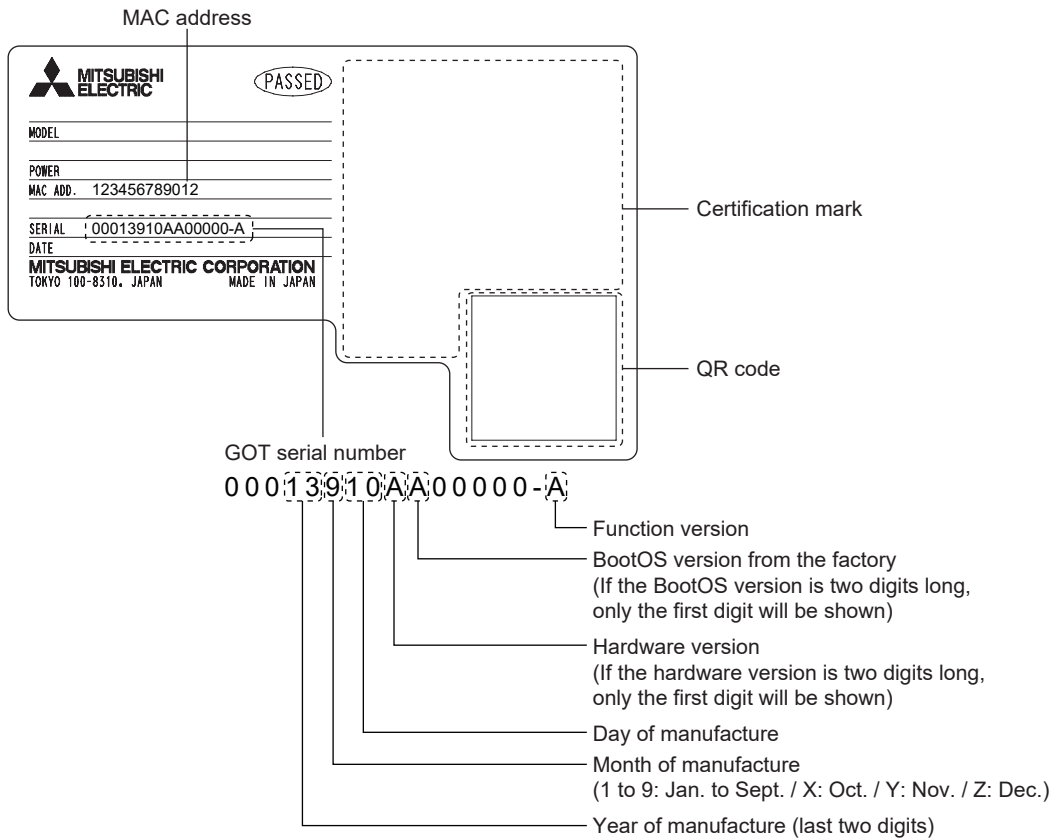

A

Appendix 2.2 Packing box

The conforming standards can be confirmed by the label on the packing box.
Note that the position of the label differs depending on the model or the shipment date.

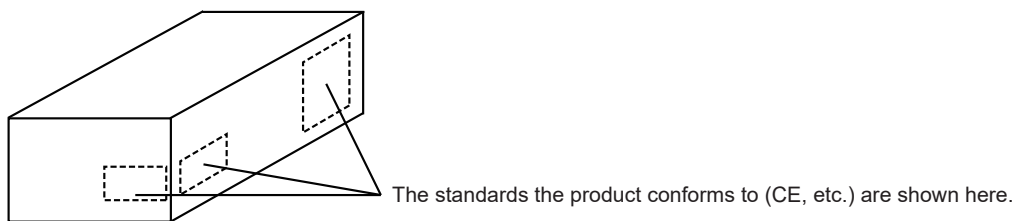

Appendix 3 Transportation precautions

When transporting lithium batteries, make sure to treat them based on the transport regulations.

Appendix 3.1 Relevant models

The battery for the GOT3000 series is classified as shown in the table below.

Product	Model	Description	Handled as
Battery for GOT3000 series	GT11-50BAT (Sold separately)	Lithium battery	Non-dangerous goods

Appendix 3.2 Transportation guidelines

Products are packed properly in compliance with the transportation regulations prior to shipment. When repacking any of the unpacked products to transport it to another location, make sure to observe the IATA Dangerous Goods Regulations, IMDG Code, and other local transportation regulations.

For details, please consult your transportation company.

Appendix 4 Open source software

☞ Page 173 U-Boot

☞ Page 178 OpenSSL

☞ Page 181 TrustedFirmware-A

Appendix 4.1 U-Boot

GT37 models use U-Boot under the GNU General Public License (GPLv2).

You can obtain the source code of the software and copy, distribute, or modify the software under the GPL.

Mitsubishi Electric Corporation can provide the source code licensed under the GPL.

To obtain the source code, contact your local sales office.

Note that Mitsubishi Electric Corporation will not guarantee the provided source code if reused.

Mitsubishi Electric Corporation will not take any responsibility for the source code.

Please refrain from requesting information on open-source source code.

NOTE! This license does *not* cover the so-called "standalone" applications that use U-Boot services by means of the jump table provided by U-Boot exactly for this purpose - this is merely considered normal use of U-Boot, and does *not* fall under the heading of "derived work" -- see file Licenses/Exceptions for details.

Also note that the GPL and the other licenses are copyrighted by the Free Software Foundation and other organizations, but the instance of code that they refer to (the U-Boot source code) is copyrighted by me and others who actually wrote it.
-- Wolfgang Denk

=====
GNU GENERAL PUBLIC LICENSE
Version 2, June 1991

Copyright (C) 1989, 1991 Free Software Foundation, Inc.,
51 Franklin Street, Fifth Floor, Boston, MA 02110-1301 USA
Everyone is permitted to copy and distribute verbatim copies
of this license document, but changing it is not allowed.

Preamble

The licenses for most software are designed to take away your freedom to share and change it. By contrast, the GNU General Public License is intended to guarantee your freedom to share and change free software--to make sure the software is free for all its users. This General Public License applies to most of the Free Software Foundation's software and to any other program whose authors commit to using it. (Some other Free Software Foundation software is covered by the GNU Lesser General Public License instead.) You can apply it to your programs, too.

When we speak of free software, we are referring to freedom, not price. Our General Public Licenses are designed to make sure that you have the freedom to distribute copies of free software (and charge for this service if you wish), that you receive source code or can get it if you want it, that you can change the software or use pieces of it in new free programs; and that you know you can do these things.

To protect your rights, we need to make restrictions that forbid anyone to deny you these rights or to ask you to surrender the rights. These restrictions translate to certain responsibilities for you if you distribute copies of the software, or if you modify it.

For example, if you distribute copies of such a program, whether gratis or for a fee, you must give the recipients all the rights that you have. You must make sure that they, too, receive or can get the source code. And you must show them these terms so they know their rights.

We protect your rights with two steps: (1) copyright the software, and (2) offer you this license which gives you legal permission to copy, distribute and/or modify the software.

Also, for each author's protection and ours, we want to make certain that everyone understands that there is no warranty for this free software. If the software is modified by someone else and passed on, we want its recipients to know that what they have is not the original, so that any problems introduced by others will not reflect on the original authors' reputations.

Finally, any free program is threatened constantly by software patents. We wish to avoid the danger that redistributors of a free program will individually obtain patent licenses, in effect making the program proprietary. To prevent this, we have made it clear that any patent must be licensed for everyone's free use or not licensed at all.

The precise terms and conditions for copying, distribution and modification follow.

GNU GENERAL PUBLIC LICENSE TERMS AND CONDITIONS FOR COPYING, DISTRIBUTION AND MODIFICATION

0. This License applies to any program or other work which contains a notice placed by the copyright holder saying it may be distributed under the terms of this General Public License. The "Program", below, refers to any such program or work, and a "work based on the Program" means either the Program or any derivative work under copyright law: that is to say, a work containing the Program or a portion of it, either verbatim or with modifications and/or translated into another language. (Hereinafter, translation is included without limitation in the term "modification".) Each licensee is addressed as "you".

Activities other than copying, distribution and modification are not covered by this License; they are outside its scope. The act of running the Program is not restricted, and the output from the Program is covered only if its contents constitute a work based on the Program (independent of having been made by running the Program). Whether that is true depends on what the Program does.

1. You may copy and distribute verbatim copies of the Program's source code as you receive it, in any medium, provided that you conspicuously and appropriately publish on each copy an appropriate copyright notice and disclaimer of warranty; keep intact all the notices that refer to this License and to the absence of any warranty; and give any other recipients of the Program a copy of this License along with the Program.

You may charge a fee for the physical act of transferring a copy, and you may at your option offer warranty protection in exchange for a fee.

2. You may modify your copy or copies of the Program or any portion of it, thus forming a work based on the Program, and copy and distribute such modifications or work under the terms of Section 1 above, provided that you also meet all of these conditions:

- a) You must cause the modified files to carry prominent notices stating that you changed the files and the date of any change.
- b) You must cause any work that you distribute or publish, that in whole or in part contains or is derived from the Program or any part thereof, to be licensed as a whole at no charge to all third parties under the terms of this License.
- c) If the modified program normally reads commands interactively when run, you must cause it, when started running for such interactive use in the most ordinary way, to print or display an announcement including an appropriate copyright notice and a notice that there is no warranty (or else, saying that you provide a warranty) and that users may redistribute the program under these conditions, and telling the user how to view a copy of this License. (Exception: if the Program itself is interactive but does not normally print such an announcement, your work based on the Program is not required to print an announcement.)

These requirements apply to the modified work as a whole. If identifiable sections of that work are not derived from the Program, and can be reasonably considered independent and separate works in themselves, then this License, and its terms, do not apply to those sections when you distribute them as separate works. But when you distribute the same sections as part of a whole which is a work based on the Program, the distribution of the whole must be on the terms of this License, whose permissions for other licensees extend to the entire whole, and thus to each and every part regardless of who wrote it.

Thus, it is not the intent of this section to claim rights or contest your rights to work written entirely by you; rather, the intent is to exercise the right to control the distribution of derivative or collective works based on the Program.

In addition, mere aggregation of another work not based on the Program with the Program (or with a work based on the Program) on a volume of a storage or distribution medium does not bring the other work under the scope of this License.

3. You may copy and distribute the Program (or a work based on it, under Section 2) in object code or executable form under the terms of Sections 1 and 2 above provided that you also do one of the following:

- a) Accompany it with the complete corresponding machine-readable source code, which must be distributed under the terms of Sections 1 and 2 above on a medium customarily used for software interchange; or,
- b) Accompany it with a written offer, valid for at least three years, to give any third party, for a charge no more than your cost of physically performing source distribution, a complete machine-readable copy of the corresponding source code, to be distributed under the terms of Sections 1 and 2 above on a medium customarily used for software interchange; or,
- c) Accompany it with the information you received as to the offer to distribute corresponding source code. (This alternative is allowed only for noncommercial distribution and only if you received the program in object code or executable form with such an offer, in accord with Subsection b above.)

The source code for a work means the preferred form of the work for making modifications to it. For an executable work, complete source code means all the source code for all modules it contains, plus any associated interface definition files, plus the scripts used to control compilation and installation of the executable. However, as a special exception, the source code distributed need not include anything that is normally distributed (in either source or binary form) with the major components (compiler, kernel, and so on) of the operating system on which the executable runs, unless that component itself accompanies the executable.

If distribution of executable or object code is made by offering access to copy from a designated place, then offering equivalent access to copy the source code from the same place counts as distribution of the source code, even though third parties are not compelled to copy the source along with the object code.

4. You may not copy, modify, sublicense, or distribute the Program except as expressly provided under this License. Any attempt otherwise to copy, modify, sublicense or distribute the Program is void, and will automatically terminate your rights under this License. However, parties who have received copies, or rights, from you under this License will not have their licenses terminated so long as such parties remain in full compliance.

5. You are not required to accept this License, since you have not signed it. However, nothing else grants you permission to modify or distribute the Program or its derivative works. These actions are prohibited by law if you do not accept this License. Therefore, by modifying or distributing the Program (or any work based on the Program), you indicate your acceptance of this License to do so, and all its terms and conditions for copying, distributing or modifying the Program or works based on it.

6. Each time you redistribute the Program (or any work based on the Program), the recipient automatically receives a license from the original licensor to copy, distribute or modify the Program subject to these terms and conditions. You may not impose any further restrictions on the recipients' exercise of the rights granted herein. You are not responsible for enforcing compliance by third parties to this License.

7. If, as a consequence of a court judgment or allegation of patent infringement or for any other reason (not limited to patent issues), conditions are imposed on you (whether by court order, agreement or otherwise) that contradict the conditions of this License, they do not excuse you from the conditions of this License. If you cannot distribute so as to satisfy simultaneously your obligations under this License and any other pertinent obligations, then as a consequence you may not distribute the Program at all. For example, if a patent license would not permit royalty-free redistribution of the Program by all those who receive copies directly or indirectly through you, then the only way you could satisfy both it and this License would be to refrain entirely from distribution of the Program.

If any portion of this section is held invalid or unenforceable under any particular circumstance, the balance of the section is intended to apply and the section as a whole is intended to apply in other circumstances.

It is not the purpose of this section to induce you to infringe any patents or other property right claims or to contest validity of any such claims; this section has the sole purpose of protecting the integrity of the free software distribution system, which is implemented by public license practices. Many people have made generous contributions to the wide range of software distributed through that system in reliance on consistent application of that system; it is up to the author/donor to decide if he or she is willing to distribute software through any other system and a licensee cannot impose that choice.

This section is intended to make thoroughly clear what is believed to be a consequence of the rest of this License.

8. If the distribution and/or use of the Program is restricted in certain countries either by patents or by copyrighted interfaces, the original copyright holder who places the Program under this License may add an explicit geographical distribution limitation excluding those countries, so that distribution is permitted only in or among countries not thus excluded. In such case, this License incorporates the limitation as if written in the body of this License.

9. The Free Software Foundation may publish revised and/or new versions of the General Public License from time to time. Such new versions will be similar in spirit to the present version, but may differ in detail to address new problems or concerns.

Each version is given a distinguishing version number. If the Program specifies a version number of this License which applies to it and "any later version", you have the option of following the terms and conditions either of that version or of any later version published by the Free Software Foundation. If the Program does not specify a version number of this License, you may choose any version ever published by the Free Software Foundation.

10. If you wish to incorporate parts of the Program into other free programs whose distribution conditions are different, write to the author to ask for permission. For software which is copyrighted by the Free Software Foundation, write to the Free Software Foundation; we sometimes make exceptions for this. Our decision will be guided by the two goals of preserving the free status of all derivatives of our free software and of promoting the sharing and reuse of software generally.

NO WARRANTY

11. BECAUSE THE PROGRAM IS LICENSED FREE OF CHARGE, THERE IS NO WARRANTY FOR THE PROGRAM, TO THE EXTENT PERMITTED BY APPLICABLE LAW. EXCEPT WHEN OTHERWISE STATED IN WRITING THE COPYRIGHT HOLDERS AND/OR OTHER PARTIES PROVIDE THE PROGRAM "AS IS" WITHOUT WARRANTY OF ANY KIND, EITHER EXPRESSED OR IMPLIED, INCLUDING, BUT NOT LIMITED TO, THE IMPLIED WARRANTIES OF MERCHANTABILITY AND FITNESS FOR A PARTICULAR PURPOSE. THE ENTIRE RISK AS TO THE QUALITY AND PERFORMANCE OF THE PROGRAM IS WITH YOU. SHOULD THE PROGRAM PROVE DEFECTIVE, YOU ASSUME THE COST OF ALL NECESSARY SERVICING, REPAIR OR CORRECTION.

12. IN NO EVENT UNLESS REQUIRED BY APPLICABLE LAW OR AGREED TO IN WRITING WILL ANY COPYRIGHT HOLDER, OR ANY OTHER PARTY WHO MAY MODIFY AND/OR REDISTRIBUTE THE PROGRAM AS PERMITTED ABOVE, BE LIABLE TO YOU FOR DAMAGES, INCLUDING ANY GENERAL, SPECIAL, INCIDENTAL OR CONSEQUENTIAL DAMAGES ARISING OUT OF THE USE OR INABILITY TO USE THE PROGRAM (INCLUDING BUT NOT LIMITED TO LOSS OF DATA OR DATA BEING RENDERED INACCURATE OR LOSSES SUSTAINED BY YOU OR THIRD PARTIES OR A FAILURE OF THE PROGRAM TO OPERATE WITH ANY OTHER PROGRAMS), EVEN IF SUCH HOLDER OR OTHER PARTY HAS BEEN ADVISED OF THE POSSIBILITY OF SUCH DAMAGES.

END OF TERMS AND CONDITIONS

Appendix 4.2 OpenSSL

Apache License
Version 2.0, January 2004
<https://www.apache.org/licenses/>

TERMS AND CONDITIONS FOR USE, REPRODUCTION, AND DISTRIBUTION

1. Definitions.

"License" shall mean the terms and conditions for use, reproduction, and distribution as defined by Sections 1 through 9 of this document.

"Licensor" shall mean the copyright owner or entity authorized by the copyright owner that is granting the License.

"Legal Entity" shall mean the union of the acting entity and all other entities that control, are controlled by, or are under common control with that entity. For the purposes of this definition, "control" means (i) the power, direct or indirect, to cause the direction or management of such entity, whether by contract or otherwise, or (ii) ownership of fifty percent (50%) or more of the outstanding shares, or (iii) beneficial ownership of such entity.

"You" (or "Your") shall mean an individual or Legal Entity exercising permissions granted by this License.

"Source" form shall mean the preferred form for making modifications, including but not limited to software source code, documentation source, and configuration files.

"Object" form shall mean any form resulting from mechanical transformation or translation of a Source form, including but not limited to compiled object code, generated documentation, and conversions to other media types.

"Work" shall mean the work of authorship, whether in Source or Object form, made available under the License, as indicated by a copyright notice that is included in or attached to the work (an example is provided in the Appendix below).

"Derivative Works" shall mean any work, whether in Source or Object form, that is based on (or derived from) the Work and for which the editorial revisions, annotations, elaborations, or other modifications represent, as a whole, an original work of authorship. For the purposes of this License, Derivative Works shall not include works that remain separable from, or merely link (or bind by name) to the interfaces of, the Work and Derivative Works thereof.

"Contribution" shall mean any work of authorship, including the original version of the Work and any modifications or additions to that Work or Derivative Works thereof, that is intentionally submitted to Licensor for inclusion in the Work by the copyright owner or by an individual or Legal Entity authorized to submit on behalf of the copyright owner. For the purposes of this definition, "submitted" means any form of electronic, verbal, or written communication sent to the Licensor or its representatives, including but not limited to communication on electronic mailing lists, source code control systems, and issue tracking systems that are managed by, or on behalf of, the Licensor for the purpose of discussing and improving the Work, but excluding communication that is conspicuously marked or otherwise designated in writing by the copyright owner as "Not a Contribution."

"Contributor" shall mean Licensor and any individual or Legal Entity on behalf of whom a Contribution has been received by Licensor and subsequently incorporated within the Work.

2. Grant of Copyright License. Subject to the terms and conditions of this License, each Contributor hereby grants to You a perpetual, worldwide, non-exclusive, no-charge, royalty-free, irrevocable copyright license to reproduce, prepare Derivative Works of, publicly display, publicly perform, sublicense, and distribute the Work and such Derivative Works in Source or Object form.
3. Grant of Patent License. Subject to the terms and conditions of this License, each Contributor hereby grants to You a perpetual, worldwide, non-exclusive, no-charge, royalty-free, irrevocable (except as stated in this section) patent license to make, have made, use, offer to sell, sell, import, and otherwise transfer the Work, where such license applies only to those patent claims licensable by such Contributor that are necessarily infringed by their Contribution(s) alone or by combination of their Contribution(s) with the Work to which such Contribution(s) was submitted. If You institute patent litigation against any entity (including a cross-claim or counterclaim in a lawsuit) alleging that the Work or a Contribution incorporated within the Work constitutes direct or contributory patent infringement, then any patent licenses granted to You under this License for that Work shall terminate as of the date such litigation is filed.
4. Redistribution. You may reproduce and distribute copies of the Work or Derivative Works thereof in any medium, with or without modifications, and in Source or Object form, provided that You meet the following conditions:
 - (a) You must give any other recipients of the Work or Derivative Works a copy of this License; and
 - (b) You must cause any modified files to carry prominent notices stating that You changed the files; and
 - (c) You must retain, in the Source form of any Derivative Works that You distribute, all copyright, patent, trademark, and attribution notices from the Source form of the Work, excluding those notices that do not pertain to any part of the Derivative Works; and
 - (d) If the Work includes a "NOTICE" text file as part of its distribution, then any Derivative Works that You distribute must include a readable copy of the attribution notices contained within such NOTICE file, excluding those notices that do not pertain to any part of the Derivative Works, in at least one of the following places: within a NOTICE text file distributed as part of the Derivative Works; within the Source form or documentation, if provided along with the Derivative Works; or, within a display generated by the Derivative Works, if and wherever such third-party notices normally appear. The contents of the NOTICE file are for informational purposes only and do not modify the License. You may add Your own attribution notices within Derivative Works that You distribute, alongside or as an addendum to the NOTICE text from the Work, provided that such additional attribution notices cannot be construed as modifying the License.

You may add Your own copyright statement to Your modifications and may provide additional or different license terms and conditions for use, reproduction, or distribution of Your modifications, or for any such Derivative Works as a whole, provided Your use, reproduction, and distribution of the Work otherwise complies with the conditions stated in this License.



5. Submission of Contributions. Unless You explicitly state otherwise, any Contribution intentionally submitted for inclusion in the Work by You to the Licensor shall be under the terms and conditions of this License, without any additional terms or conditions.
Notwithstanding the above, nothing herein shall supersede or modify the terms of any separate license agreement you may have executed with Licensor regarding such Contributions.
6. Trademarks. This License does not grant permission to use the trade names, trademarks, service marks, or product names of the Licensor, except as required for reasonable and customary use in describing the origin of the Work and reproducing the content of the NOTICE file.
7. Disclaimer of Warranty. Unless required by applicable law or agreed to in writing, Licensor provides the Work (and each Contributor provides its Contributions) on an "AS IS" BASIS, WITHOUT WARRANTIES OR CONDITIONS OF ANY KIND, either express or implied, including, without limitation, any warranties or conditions of TITLE, NON-INFRINGEMENT, MERCHANTABILITY, or FITNESS FOR A PARTICULAR PURPOSE. You are solely responsible for determining the appropriateness of using or redistributing the Work and assume any risks associated with Your exercise of permissions under this License.
8. Limitation of Liability. In no event and under no legal theory, whether in tort (including negligence), contract, or otherwise, unless required by applicable law (such as deliberate and grossly negligent acts) or agreed to in writing, shall any Contributor be liable to You for damages, including any direct, indirect, special, incidental, or consequential damages of any character arising as a result of this License or out of the use or inability to use the Work (including but not limited to damages for loss of goodwill, work stoppage, computer failure or malfunction, or any and all other commercial damages or losses), even if such Contributor has been advised of the possibility of such damages.
9. Accepting Warranty or Additional Liability. While redistributing the Work or Derivative Works thereof, You may choose to offer, and charge a fee for, acceptance of support, warranty, indemnity, or other liability obligations and/or rights consistent with this License. However, in accepting such obligations, You may act only on Your own behalf and on Your sole responsibility, not on behalf of any other Contributor, and only if You agree to indemnify, defend, and hold each Contributor harmless for any liability incurred by, or claims asserted against, such Contributor by reason of your accepting any such warranty or additional liability.

END OF TERMS AND CONDITIONS

Appendix 4.3 TrustedFirmware-A

The copyright and permission notices of TrustedFirmware-A are described below.

Copyright (c) 2013-2019, ARM Limited and Contributors. All rights reserved.

Redistribution and use in source and binary forms, with or without modification, are permitted provided that the following conditions are met:

- Redistributions of source code must retain the above copyright notice, this list of conditions and the following disclaimer.
- Redistributions in binary form must reproduce the above copyright notice, this list of conditions and the following disclaimer in the documentation and/or other materials provided with the distribution.
- Neither the name of Arm nor the names of its contributors may be used to endorse or promote products derived from this software without specific prior written permission.

THIS SOFTWARE IS PROVIDED BY THE COPYRIGHT HOLDERS AND CONTRIBUTORS "AS IS" AND ANY EXPRESS OR IMPLIED WARRANTIES, INCLUDING, BUT NOT LIMITED TO, THE IMPLIED WARRANTIES OF MERCHANTABILITY AND FITNESS FOR A PARTICULAR PURPOSE ARE DISCLAIMED. IN NO EVENT SHALL THE COPYRIGHT HOLDER OR CONTRIBUTORS BE LIABLE FOR ANY DIRECT, INDIRECT, INCIDENTAL, SPECIAL, EXEMPLARY, OR CONSEQUENTIAL DAMAGES (INCLUDING, BUT NOT LIMITED TO, PROCUREMENT OF SUBSTITUTE GOODS OR SERVICES; LOSS OF USE, DATA, OR PROFITS; OR BUSINESS INTERRUPTION) HOWEVER CAUSED AND ON ANY THEORY OF LIABILITY, WHETHER IN CONTRACT, STRICT LIABILITY, OR TORT (INCLUDING NEGLIGENCE OR OTHERWISE) ARISING IN ANY WAY OUT OF THE USE OF THIS SOFTWARE, EVEN IF ADVISED OF THE POSSIBILITY OF SUCH DAMAGE.

Appendix 5 Précautions d'installation du GOT

Installez le GOT en tenant compte des dimensions internes du panneau de contrôle et de la zone d'installation proscrite. Selon le type de câble de connexion branché sur le GOT, une distance supérieure aux dimensions données peut être nécessaire.

Installez le GOT en tenant compte des dimensions de connecteur et du rayon de courbure du câble.

Appendix 6 Position d'installation

Veillez à installer le GOT à une certaine distance des structures et des autres appareils.

Cette section décrit la distance nécessaire pour chaque modèle GOT.

☞ Page 183 GT37

Appendix 6.1 GT37

☞ Page 184 GT3715-FH, GT3712-WX

☞ Page 185 GT3715-X, GT3712-X, GT3710-X, GT3708-X

☞ Page 186 Profondeur avec une unité d'extension installée

Précautions

■ Position d'installation lors du branchement des câbles et des unités d'extension

Selon les câbles et les unités utilisés pour le GOT, une distance plus importante peut être nécessaire.

Installez le GOT en tenant compte des dimensions de connecteur et du rayon de courbure du câble.

Reportez-vous à la page suivante pour connaître la longueur de déploiement du câble à partir du bas du GOT.

☞ Page 164 Cable bend radius for GT37 with an extension unit

■ Orientation pour l'installation verticale

Lorsque vous installez le GOT à la verticale, assurez-vous que le couvercle de la carte SD est dirigé vers le bas.

☞ Page 58 GT37

GT3715-FH, GT3712-WX

Le tableau suivant répertorie la distance requise entre le GOT et les autres appareils.

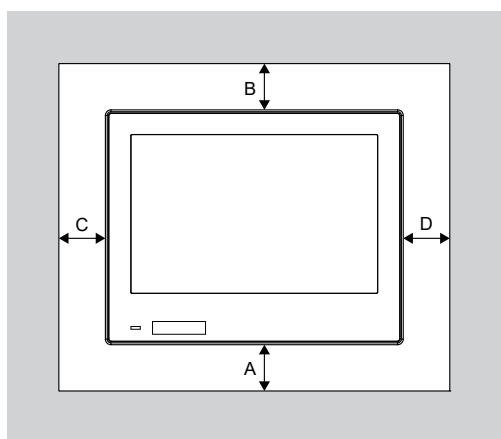

Horizontal

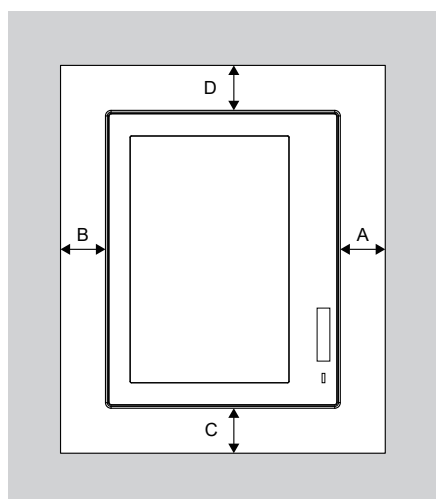
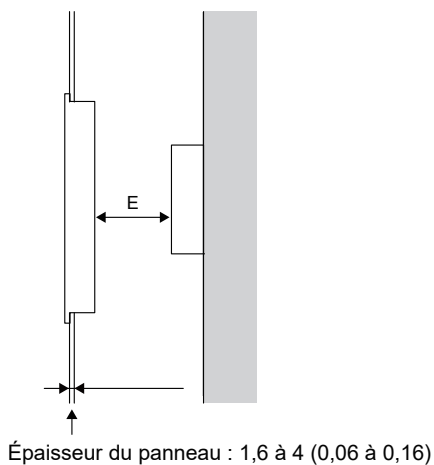

Vertical

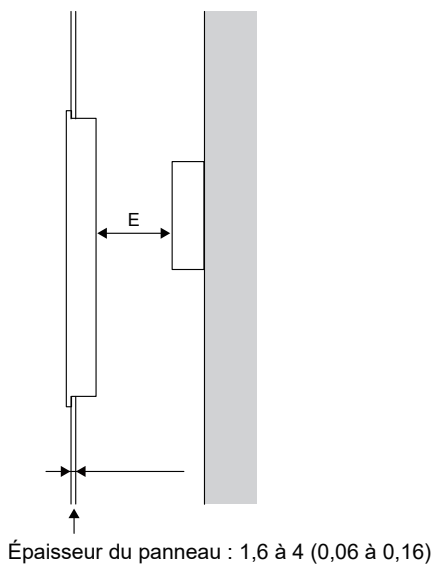

Unité : mm (po.)

Rubrique		GT3715-FH	GT3712-WX
A		49 (1,93) ou plus	
B	Horizontal	79 (3,11) ou plus	
	Vertical	49 (1,93) ou plus	
C		50 (1,97) ou plus	
D	Horizontal	50 (1,97) ou plus	
	Vertical	80 (3,15) ou plus	
E		100 (3,94) ou plus	

GT3715-X, GT3712-X, GT3710-X, GT3708-X

Le tableau suivant répertorie la distance requise entre le GOT et les autres appareils.

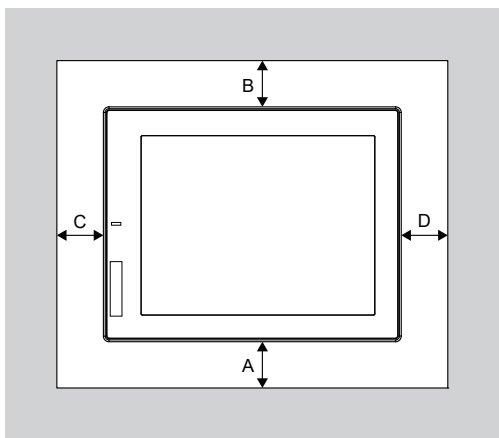

Horizontal

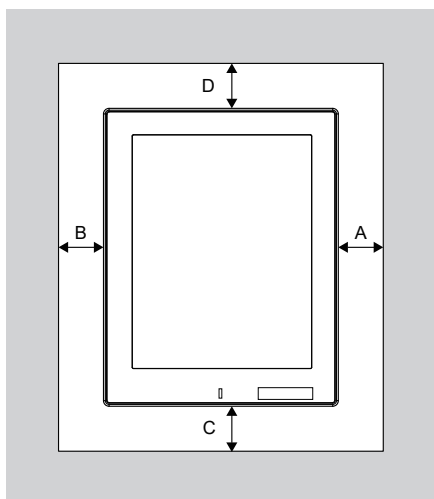
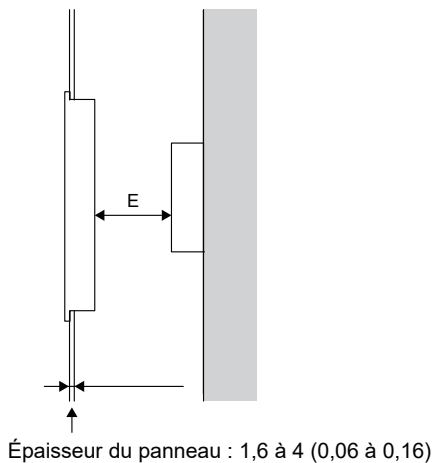

Vertical

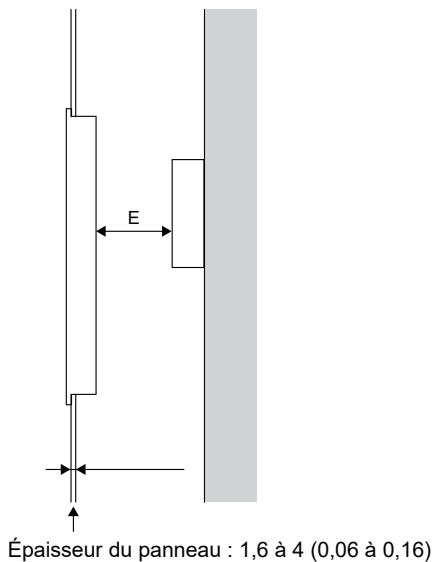

Unité : mm (po.)

Rubrique		GT3715-X	GT3712-X	GT3710-X	GT3708-X
A		49 (1,93) ou plus			
B	Horizontal	79 (3,11) ou plus			
	Vertical	49 (1,93) ou plus			
C		50 (1,97) ou plus			
D	Horizontal	50 (1,97) ou plus			
	Vertical	80 (3,15) ou plus			
E		100 (3,94) ou plus			

A

Profondeur avec une unité d'extension installée

Cette section décrit la profondeur du GOT lorsqu'une unité d'extension est installée.

Une unité de convertisseur d'interface d'extension (GT37-IF2000) est nécessaire pour installer une unité d'extension sur le GOT.

Une seule unité d'extension peut être installée sur l'unité de convertisseur d'interface d'extension.

Reportez-vous à la page suivante pour connaître la méthode d'installation de l'unité d'extension et de l'unité de convertisseur d'interface d'extension.

☞ Page 75 Installation

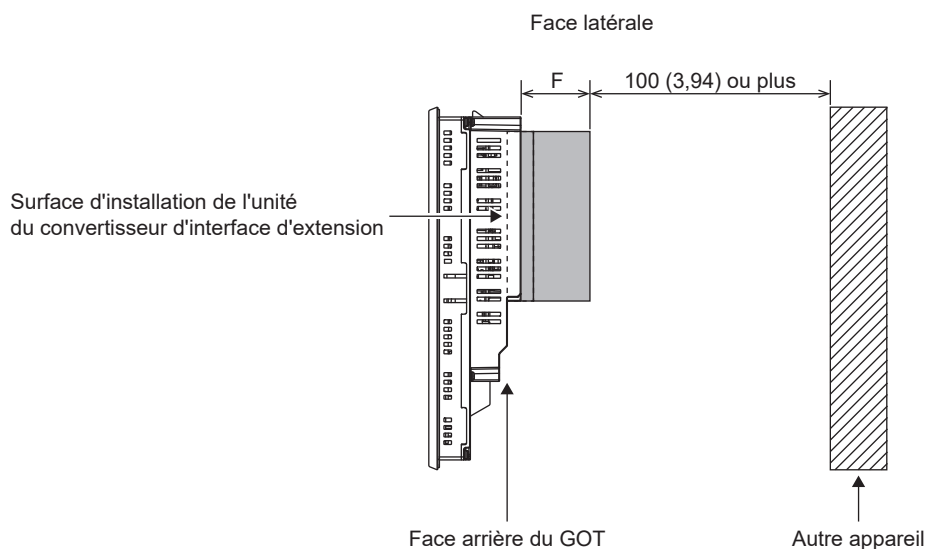

Unité : mm (po.)

Unité d'extension	F	
Unité de communication en série	GT15-RS2-9P	30.5 (1.2)
	GT15-RS4-9S	30.5 (1.2)
	GT15-RS4-TE	30.5 (1.2)
Unité de communication CC-Link IE TSN	GT25-J71GN13-T2	28 (1.1)
Unité de communication de réseau à contrôleur CC-Link IE	GT15-J71GP23-SX	44.5 (1.75)
Unité de communication de réseau de terrain CC-Link IE	GT15-J71GF13-T2	44.5 (1.75)
Unité de communication CC-Link	GT15-J61BT13	30.5 (1.2)
Unité de connexion de bus	GT15-QBUS	30.5 (1.2)
	GT15-QBUS2	30.5 (1.2)
	GT15-75QBUSL	17.5 (0.69)
	GT15-75QBUS2L	17.5 (0.69)
Unité de communication MELSECNET/H	GT15-J71LP23-25	30.5 (1.2)
	GT15-J71BR13	30.5 (1.2)
Unité d'E/S externe	GT15-DIO	30.5 (1.2)
	GT15-DIOR	30.5 (1.2)

Appendix 7 Température intérieure du tableau de commande et angle d'installation de GOT

Page 187 GT37

Installez le GOT avec l'afficheur positionné comme représenté ci-dessous.

Appendix 7.1 GT37

Installation horizontale

- Lorsque le GOT est installé à un angle compris entre 60° et 105° , la température intérieure du tableau de commande doit être inférieure ou égale à 55°C .
- Lorsque le GOT est installé à un angle inférieur à 60° ou supérieur à 105° , la température intérieure du tableau de commande doit être inférieure ou égale à 40°C .

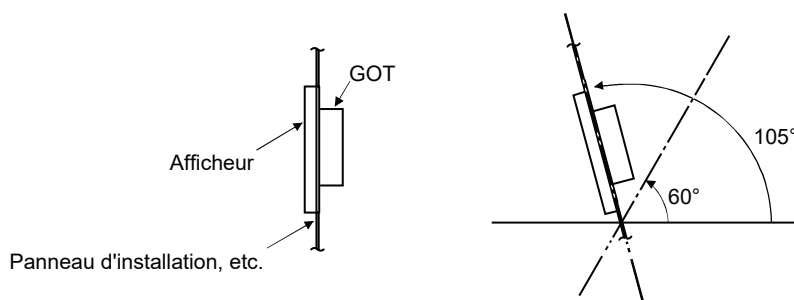

Point

Vérifiez que la température intérieure du tableau de commande ne dépasse pas les températures indiquées ci-dessus.

Dans le cas contraire, la durée de vie du produit peut être impactée.

A

Installation verticale

- Lorsque le GOT est installé à 90° , la température intérieure du tableau de commande doit être inférieure ou égale à 55°C .
- Lorsque le GOT est installé à un angle inférieur à 60° ou supérieur à 105° , la température intérieure du tableau de commande doit être inférieure ou égale à 40°C .

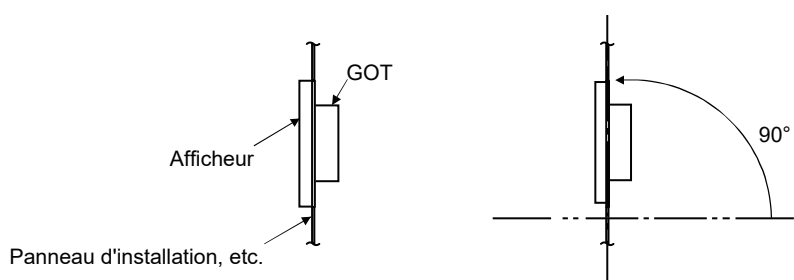

Point

Vérifiez que la température intérieure du tableau de commande ne dépasse pas les températures indiquées ci-dessus.

Dans le cas contraire, la durée de vie du produit peut être impactée.

Revisions

*The manual number is given on the bottom left of the back cover.

Revision date	*Manual number	Revision
April 2025	SH(NA)-082591ENG-A	First edition
December 2025	SH(NA)-082591ENG-B	Compatible with GT Works3 Version 1.410C <ul style="list-style-type: none">• GT3715-X is supported.• CC-Link IE Controller Network communication unit is supported.• CC-Link communication unit is supported.• Bus connection unit is supported.• MELSECNET/H communication unit is supported.• External I/O unit is supported.
April 2026	SH(NA)-082591ENG-C	Some corrections

This manual confers no industrial property rights or any rights of any other kind, nor does it confer any patent licenses. Mitsubishi Electric Corporation cannot be held responsible for any problems involving industrial property rights which may occur as a result of using the contents noted in this manual.

© 2025 MITSUBISHI ELECTRIC CORPORATION

Warranty

Please check the following product warranty details before using this product.

■1. Gratis Warranty Term and Gratis Warranty Range

If any faults or defects (hereinafter "Failure") found to be the responsibility of Mitsubishi occurs during use of the product within the gratis warranty term, the product shall be repaired at no cost via the sales representative or Mitsubishi Service Company. However, if repairs are required onsite at domestic or overseas location, expenses to send an engineer will be solely at the customer's discretion.

Mitsubishi shall not be held responsible for any re-commissioning, maintenance, or testing on-site that involves replacement of the failed module.

(1) Gratis Warranty Term

The gratis warranty term of the product shall be for thirty-six (36) months after the date of purchase or delivery to a designated place.

Note that after manufacture and shipment from Mitsubishi, the maximum distribution period shall be six (6) months, and the longest gratis warranty term after manufacturing shall be forty-two (42) months.

The gratis warranty term of repair parts shall not exceed the gratis warranty term before repairs.

(2) Gratis Warranty Range

- (a) The customer shall be responsible for the primary failure diagnosis unless otherwise specified.
If requested by the customer, Mitsubishi Electric Corporation or its representative firm may carry out the primary failure diagnosis at the customer's expense.
The primary failure diagnosis will, however, be free of charge should the cause of failure be attributable to Mitsubishi Electric Corporation.
- (b) The range shall be limited to normal use within the usage state, usage methods, and usage environment, etc., which follow the conditions and precautions, etc., given in the instruction manual, user's manual and caution labels on the product.
- (c) Even within the gratis warranty term, repairs shall be charged in the following cases.
 - Failure occurring from inappropriate storage or handling, carelessness or negligence by the user.
Failure caused by the user's hardware or software design.
 - Failure caused by unapproved modifications, etc., to the product by the user.
 - When the Mitsubishi product is assembled into a user's device, Failure that could have been avoided if functions or structures, judged as necessary in the legal safety measures the user's device is subject to or as necessary by industry standards, had been provided.
 - Failure that could have been avoided if consumable parts designated in the instruction manual had been correctly serviced or replaced.
 - Replacing consumable parts such as a battery
 - Failure caused by external irresistible forces such as fires or abnormal voltages, and Failure caused by force majeure such as earthquakes, lightning, wind and water damage.
 - Failure caused by reasons that could not be predicted by scientific technology standards at the time of shipment from Mitsubishi.
 - Any other failure found not to be the responsibility of Mitsubishi or that admitted not to be so by the user.

■2. Onerous repair term after discontinuation of production

- (1) Mitsubishi shall accept onerous product repairs for seven (7) years after production of the product is discontinued. Discontinuation of production shall be notified with Mitsubishi Technical Bulletins, etc.
- (2) Mitsubishi shall not accept a request for product supply (including spare parts) after production is discontinued.

■3. Overseas service

Overseas, repairs shall be accepted by Mitsubishi's local overseas FA Center.

Note that the repair conditions at each FA Center may differ.

■4. Exclusion of loss in opportunity and secondary loss from warranty liability

Regardless of the gratis warranty term, Mitsubishi shall not be liable for compensation to:

- (1) Damages caused by any cause found not to be the responsibility of Mitsubishi.
- (2) Loss in opportunity, lost profits incurred to the user by Failures of Mitsubishi products.
- (3) Special damages and secondary damages whether foreseeable or not, compensation for accidents, and compensation for damages to products other than Mitsubishi products.
- (4) Replacement by the user, maintenance of on-site equipment, start-up test run and other tasks.

■5. Changes in product specifications

The specifications given in the catalogs, manuals, or technical documents are subject to change without prior notice.

Trademarks

MELSEC, MELSOFT, MELHMI, GOT, CC-Link, and CC-Link IE are registered trademarks or trademarks of Mitsubishi Electric Corporation in Japan and other countries.

Microsoft, Excel, Internet Explorer, Microsoft Edge, Visual Basic, Visual C++, Visual C#, Windows, and Windows Server are trademarks of the Microsoft group of companies.

MODBUS is a registered trademark of Schneider Electric SA.

VNC is a registered trademark of RealVNC Ltd. in the United States and other countries.

Unicode is either a registered trademark or a trademark of Unicode, Inc. in the United States and other countries.

Adobe and Adobe Reader are registered trademarks of Adobe Inc.

Oracle and JavaScript are registered trademarks of Oracle Corporation and/or its affiliates in the United States and other countries.

QR Code is a registered trademark of DENSO WAVE INCORPORATED.

Android and Google Chrome are registered trademarks or trademarks of Google LLC.

Safari is a trademark of Apple Inc.

IOS (iOS) is a registered trademark or trademark of Cisco Systems, Inc. and its affiliates in the United States and other countries, and is used under the license by Apple Inc.

Intel and Intel Core are registered trademarks or trademarks of Intel Corporation in the United States and other countries.

Bitmap (bitmap font) is a trademark of Morisawa Inc.

Mobile Font is a trademark of Morisawa Inc.

OPC UA is a registered trademark or trademark of the OPC Foundation in the United States and other countries.

Secomea, GateManager, LinkManager, and SiteManager are registered trademarks of SECOMEA A/S.

The company names, system names and product names mentioned in this technical bulletin are either registered trademarks or trademarks of their respective companies.

The names may not be marked with a trademark symbol (™ or ®) in this manual.

Copyrights

For information on the open source software used in this product, refer to the following:

 Page 173 Open source software

The system font of this product uses Mobile Font, a universal design font by Morisawa Inc.

The copyright of these fonts belongs to Morisawa Inc.

The screens (screenshots) are used in accordance with the Microsoft Corporation guideline.

SH(NA)-082591ENG-C(2604)MEE

MODEL: GOT3000-U-HW-E

MITSUBISHI ELECTRIC CORPORATION

HEAD OFFICE: TOKYO BLDG., 2-7-3, MARUNOUCHI, CHIYODA-KU, TOKYO 100-8310, JAPAN
NAGOYA WORKS: 1-14, YADA-MINAMI 5-CHOME, HIGASHI-KU, NAGOYA 461-8670, JAPAN

When exported from Japan, this manual does not require application to the
Ministry of Economy, Trade and Industry for service transaction permission.

Specifications subject to change without notice.