

Programmable Controller

MELSEC iQ-R
series

MELSEC iQ-R I/O Module (With Safety Functions) User's Manual

-RX40NC6S-TS
-RY48PT20S-TS



SAFETY PRECAUTIONS

(Read these precautions before using this product.)

Before using this product, please read this manual and the relevant manuals carefully and pay full attention to safety to handle the product correctly.

The precautions given in this manual are concerned with this product only. For the safety precautions of the programmable controller system, refer to the MELSEC iQ-R Module Configuration Manual.

In this manual, the safety precautions are classified into two levels: "⚠ WARNING" and "⚠ CAUTION".

 WARNING	Indicates that incorrect handling may cause hazardous conditions, resulting in death or severe injury.
 CAUTION	Indicates that incorrect handling may cause hazardous conditions, resulting in minor or moderate injury or property damage.

Under some circumstances, failure to observe the precautions given under "⚠ CAUTION" may lead to serious consequences.

Observe the precautions of both levels because they are important for personal and system safety.

Make sure that the end users read this manual and then keep the manual in a safe place for future reference.

[Design Precautions]

WARNING

- When the I/O module (with safety functions) detects an error in an external power supply or a failure in the module, it turns off the outputs. Configure an external circuit to ensure that the power source of a hazard is shut off by turning off the outputs. Failure to do so may result in an accident due to an incorrect output or malfunction.
 - When a load current exceeding the rated current or an overcurrent caused by a load short-circuit flows, the I/O module (with safety functions) defines it as a fault and turns off the outputs. Note that if the overcurrent state continues for a long time, it may cause smoke and fire. To prevent this, configure an external safety circuit, such as a fuse.
 - At the start-up of the system, if the external power supply is short-circuited by the output wiring of the I/O module (with safety functions), or if the external power supply is connected with a wrong polarity, a load may turn on just after the power-on. Configure an interlock circuit to ensure that the entire system will always operate safely.
 - When a safety I/O refresh error (error code: 1A03H to 1A09H) occurs in the I/O module (with safety functions), the error module will be as follows. Check the safety I/O refresh status and configure an interlock circuit in the program to ensure that the entire system will operate safely. Failure to do so may result in an accident due to an incorrect output or malfunction.
 - (1) All data that are output from the I/O module (with safety functions) are turned off.
 - (2) All data that are sent from the I/O module (with safety functions) to the Safety CPU are turned off.
 - Do not write any data to the "system area" and "write-prohibited area" of the buffer memory in the module. Also, do not use any "use prohibited" signals as an I/O signal. If these operations are performed, the correct operation of the module cannot be guaranteed. For the "system area", "write-prohibited area", and the "use prohibited" signals, refer to this manual.
 - To satisfy SIL3, Category 4 PLe, use input devices with normally closed contacts. Inputs using the devices with normally open contacts do not satisfy SIL3, Category 4 PLe.
 - When "Safety I/O refresh continues (Without output interlock)" is selected for the operation setting of external power supply voltage error detection, configure an external interlock circuit for the safety outputs to prevent unintended restart.
-

[Design Precautions]

CAUTION

- Do not install the wiring of external devices or communication cables together with the main circuit lines or power cables. Doing so may result in malfunction due to noise. Keep a distance of 100mm or more between those cables.
 - Select the external devices to be connected to the module by referring to the performance specifications in this manual and considering the maximum inrush current. Connecting a device exceeding the maximum inrush current may cause malfunction or failure of the module.
-

[Security Precautions]

WARNING

- To maintain the security (confidentiality, integrity, and availability) of the programmable controller and the system against unauthorized access, denial-of-service (DoS) attacks, computer viruses, and other cyberattacks from external devices via the network, take appropriate measures such as firewalls, virtual private networks (VPNs), and antivirus solutions.
-

[Installation Precautions]

WARNING

- Shut off the external power supply (all phases) used in the system before mounting or removing the module. Failure to do so may result in electric shock or cause the module to fail or malfunction.
-

[Installation Precautions]

CAUTION

- Use the module in an environment that meets the general specifications in this manual. Failure to do so may result in electric shock, fire, malfunction, or damage to or deterioration of the product.
 - Do not directly touch any conductive parts and electronic components of the module. Doing so can cause malfunction or failure of the module.
 - After the first use of the product, do not connect/remove the connector more than 50 times (IEC 61131-2/JIS B 3502 compliant). Exceeding the limit may cause malfunction.
 - Connect each connection cable to the connector securely. Poor contact may cause malfunction.
 - To mount a module, place the concave part(s) located at the bottom onto the guide(s) of the base unit, and push in the module until the hook(s) located at the top snaps into place. Incorrect interconnection may cause malfunction, failure, or drop of the module.
 - When using the programmable controller in an environment of frequent vibrations, fix the module with a screw.
 - Beware that the module could be very hot while power is on and immediately after power-off.
 - Tighten the screws within the specified torque range. Undertightening can cause drop of the screw, short circuit, or malfunction. Overtightening can damage the screw and/or module, resulting in drop, short circuit, or malfunction.
-

[Wiring Precautions]

WARNING

- Shut off the external power supply (all phases) used in the system before installation and wiring. Failure to do so may result in electric shock or cause the module to fail or malfunction.
- After installation and wiring, attach a blank cover module (RG60) to each empty slot before powering on the system for operation. Also, attach an extension connector protective cover^{*1} to each unused extension cable connector as necessary. Directly touching any conductive parts of the connectors while power is on may result in electric shock.

*1 For details, please consult your local Mitsubishi Electric representative.

[Wiring Precautions]

CAUTION

- Individually ground the FG and LG terminals of the programmable controller with a ground resistance of 100 ohms or less. Failure to do so may result in electric shock or malfunction.
 - Check the rated voltage and terminal layout before wiring to the module, and connect the cables correctly. Connecting a power supply with a different voltage rating or incorrect wiring may cause fire or failure.
 - Prevent foreign matter such as dust or wire chips from entering the module. Such foreign matter can cause a fire, failure, or malfunction.
 - When a protective film is attached to the top of the module, remove it before system operation. If not, inadequate heat dissipation of the module may cause a fire, failure, or malfunction.
 - Securely connect the connector to the module. Poor contact may cause malfunction.
 - Do not install the control lines together with the main circuit lines or power cables. Keep a distance of 100mm or more between them. Failure to do so may result in malfunction due to noise.
 - Place the cables in a duct or clamp them. If not, dangling cables may swing or inadvertently be pulled, resulting in malfunction or damage to modules or cables. In addition, the weight of the cables may put stress on modules in an environment of strong vibrations and shocks. Do not clamp the extension cables with the jacket stripped. Doing so may change the characteristics of the cables, resulting in malfunction.
 - When an overcurrent caused by an error of an external device or a failure of the module flows for a long time, it may cause smoke and fire. To prevent this, configure an external safety circuit, such as a fuse.
 - Use the programmable controller in the control panel that meets the IP rating of 54 or higher. Wiring and replacement of the power supply module and the I/O module (with safety functions) must be performed by qualified maintenance personnel with knowledge of protection against electric shock. For wiring of the power supply module, refer to the MELSEC iQ-R Module Configuration Manual. For wiring of the I/O module (with safety functions), refer to this manual.
-

[Startup and Maintenance Precautions]

WARNING

- Do not touch any terminal while power is on. Doing so will cause electric shock or malfunction.
 - Shut off the external power supply (all phases) used in the system before cleaning the module. Failure to do so may result in electric shock.
-

[Startup and Maintenance Precautions]

CAUTION

- Do not disassemble or modify the modules. Doing so may cause failure, malfunction, injury, or a fire.
- Use any radio communication device such as a cellular phone or PHS (Personal Handy-phone System) 25cm or more away in all directions from the programmable controller. Failure to do so may cause malfunction.
- Shut off the external power supply (all phases) used in the system before mounting or removing the module. Failure to do so may cause the module to fail or malfunction.
- After the first use of the product, do not perform each of the following operations more than 50 times (IEC 61131-2/JIS B 3502 compliant).

Exceeding the limit may cause malfunction.

- Mounting/removing the module to/from the base unit
 - Mounting/removing the I/O terminal block to/from the module
 - Before handling the module, touch a conducting object such as a grounded metal to discharge the static electricity from the human body. Wearing an anti-static wrist strap (grounded) is also recommended. Not discharging the static electricity may cause the module to fail or malfunction.
 - After unpacking, eliminate static electricity from the module to prevent electrostatic discharge from affecting the module. If an electrostatically charged module comes in contact with a grounded metal object, a sudden electrostatic discharge of the module may cause failure.
For details on how to eliminate static electricity from the module, refer to the following. Antistatic Precautions Before Using MELSEC iQ-R Series Products (FA-A-0368)
 - Use a clean and dry cloth to wipe off dirt on the module.
 - Do not drop or apply strong shock to the module. Doing so may damage the module.
 - Check the I/O module (with safety functions) once a day, by turning on output signals and confirming that no error occurs.
 - Startup and maintenance of a control panel must be performed by qualified maintenance personnel with knowledge of protection against electric shock. Lock the control panel so that only qualified maintenance personnel can operate it.
-

[Disposal Precautions]

CAUTION

- When disposing of this product, treat it as industrial waste.
-

[Transportation Precautions]

CAUTION

- For shipping, always use the original packaging.
 - The halogens (such as fluorine, chlorine, bromine, and iodine), which are contained in a fumigant used for disinfection and pest control of wood packaging materials, may cause failure of the product. Prevent the entry of fumigant residues into the product or consider other methods (such as heat treatment) instead of fumigation. The disinfection and pest control measures must be applied to unprocessed raw wood.
-

[Precautions for Using Products]

WARNING

- Although MELCO has obtained the certification for Product's compliance to the international safety standards IEC 61508 and ISO 13849-1 from TUV Rheinland, this fact does not guarantee that Product will be free from any malfunction or failure.
 - With very small probability shown in PFDavg / PFH, the I/O module (with safety functions) has residual risk that input and output may remain on or off. When using this product, perform risk assessment on target equipment, and select appropriate SIL and PL, as well as reduce the risk.
 - This product complies with following requirements of international safety standards: SIL3 (IEC 61508: 2010), PLe (EN ISO 13849-1: 2015).
 - All work for safety system configuration (e.g. design, installation, operation, and maintenance) has to be conducted by the person who has sufficient knowledge and skills concerning safety standards, safety devices, and safety programmable controller.
-

CONDITIONS OF USE FOR THE PRODUCT

- (1) Although Mitsubishi Electric has obtained the certification for Product's compliance to the international safety standards IEC61508, ISO13849-1 from TUV Rheinland, this fact does not guarantee that Product will be free from any malfunction or failure. The user of this Product shall comply with any and all applicable safety standard, regulation or law and take appropriate safety measures for the system in which the Product is installed or used and shall take the second or third safety measures other than the Product. Mitsubishi Electric is not liable for damages that could have been prevented by compliance with any applicable safety standard, regulation or law.
- (2) Mitsubishi Electric prohibits the use of Products with or in any application involving, and Mitsubishi Electric shall not be liable for a default, a liability for defect warranty, a quality assurance, negligence or other tort and a product liability in these applications.
 - (a) power plants,
 - (b) trains, railway systems, airplanes, airline operations, other transportation systems,
 - (c) hospitals, medical care, dialysis and life support facilities or equipment,
 - (d) amusement equipments,
 - (e) incineration and fuel devices,
 - (f) handling of nuclear or hazardous materials or chemicals,
 - (g) mining and drilling,
 - (h) and other applications where the level of risk to human life, health or property are elevated.
- (3) Mitsubishi Electric shall have no responsibility or liability for any problems involving programmable controller trouble and system trouble caused by DoS attacks, unauthorized access, computer viruses, and other cyberattacks.

INTRODUCTION

Thank you for purchasing the Mitsubishi Electric MELSEC iQ-R series programmable controllers.

This manual describes the procedures, system configuration, and troubleshooting of the relevant products listed below.

Before using this product, please read this manual and the relevant manuals carefully and develop familiarity with the functions and performance of the MELSEC iQ-R series programmable controller to handle the product correctly.

Please make sure that the end users read this manual.

Point

The examples of I/O signals (X, Y) shown in this manual are for when 0 is set for the start I/O number of the safety I/O module. For details, refer to the following.

 MELSEC iQ-R Module Configuration Manual

Unless otherwise specified, this manual describes the examples in which the safety I/O signals are assigned as follows.

- Safety input signal: SA\X
- Safety output signal: SA\Y

Note that the examples are for when 0 is set for the start address of the device in "Safety I/O refresh device setting". For details, refer to the following.

 Page 40 Safety I/O refresh device setting

 Page 45 Safety I/O refresh device setting

Relevant products

RX40NC6S-TS, RY48PT20S-TS

CONTENTS

SAFETY PRECAUTIONS	1
CONDITIONS OF USE FOR THE PRODUCT	6
INTRODUCTION	6
RELEVANT MANUALS	10
TERMS	11
GENERIC TERMS AND ABBREVIATIONS	11
CHAPTER 1 PRODUCT LISTS	12
CHAPTER 2 PART NAMES	14
CHAPTER 3 SPECIFICATIONS	16
3.1 General Specifications	16
3.2 Performance Specifications	17
3.3 Function List	25
CHAPTER 4 PROCEDURES BEFORE OPERATION	27
4.1 Procedures Before Operation	27
4.2 Module Replacement Procedure	28
CHAPTER 5 SYSTEM CONFIGURATION	29
5.1 System Configuration	29
5.2 Applicable Systems	30
5.3 Safety Standards	31
CHAPTER 6 INSTALLATION AND WIRING	32
6.1 Installation of Safety I/O Module	32
6.2 Wiring	32
Wiring of the external power supply	36
Precautions for wiring the safety I/O module to safety devices	36
Wiring test for external output	37
CHAPTER 7 PARAMETER SETTINGS	38
7.1 Parameter Setting of the RX40NC6S-TS	39
Basic setting	39
Application setting	41
Refresh Setting	43
7.2 Parameter Setting of the RY48PT20S-TS	44
Basic setting	44
Application setting	46
Refresh Setting	47
7.3 Safety Module Validation	48
Procedure for enabling the safety module	48
CHAPTER 8 FUNCTIONS	54
8.1 Safety I/O Refresh Function	54
Safety I/O refresh	54
Safety I/O refresh interlock	58

8.2	Safety Input Function	59
	Input wiring selection function	59
	Input response time setting function	62
8.3	Safety Output Function	63
	Output wiring selection function	63
8.4	Input Diagnostic Function	65
	Double input discrepancy detection function	65
	Input dark test function	68
	Internal input dark test function	70
8.5	Output Diagnostic Function	71
	Output dark test function	71
	Output read-back function	72
8.6	Protection Functions	73
8.7	Operation Setting Function at Detection of External Power Supply Voltage Error	74
8.8	I/O LED Indication Setting Function on Error Condition	80
 CHAPTER 9 MAINTENANCE AND INSPECTION		81
9.1	Daily Inspection	81
9.2	Periodic Inspection	82
 CHAPTER 10 TROUBLESHOOTING		83
10.1	Troubleshooting with the LEDs	83
10.2	Checking the State of the Module	85
	Module diagnostics	85
10.3	Troubleshooting by Symptom	87
10.4	Troubleshooting While Proceeding Procedures Before Operation	88
	Troubleshooting on the "Safety Module Operation" window	88
10.5	Fault Examples with the Safety I/O Module	90
	Troubleshooting for input circuit	90
	Troubleshooting for output circuit	92
10.6	List of Error Codes	93
10.7	List of Event Codes	96
 APPENDICES		97
Appendix 1	I/O Signals	97
	List of I/O signals	97
	Details of input signals	99
Appendix 2	Safety I/O Signals	100
	List of safety I/O signals	100
	Details of safety input signals	102
	Details of safety output signals	104
Appendix 3	Buffer Memory	105
	List of buffer memory assignments	105
	Details of buffer memory addresses	107
Appendix 4	Compliance with EMC and Low Voltage Directives	111
	Measures to comply with the EMC Directive	111
	Measures to comply with the Low Voltage Directive	119
Appendix 5	Checking Production Information and Firmware Version	120
	Checking methods	120
Appendix 6	External Dimensions	122

INDEX

123

REVISIONS125
WARRANTY126
TRADEMARKS128

RELEVANT MANUALS

Manual name [manual number]	Description	Available form
MELSEC iQ-R I/O Module (With Safety Functions) User's Manual [SH-082639ENG] (this manual)	Specifications, procedures before operation, system configuration, installation, wiring, parameter settings, functions, maintenance and inspection, and troubleshooting of the safety I/O module	Print book e-Manual PDF
MELSEC iQ-R Module Configuration Manual [SH-081262ENG]	Combinations of MELSEC iQ-R series modules to be used, common information on installations/wiring for configuring systems, and specifications of the power supply module, base unit, SD memory card, and battery	Print book e-Manual PDF
MELSEC iQ-R CPU Module User's Manual (Application) [SH-081264ENG]	Memory, functions, devices, and parameters of the CPU module	Print book e-Manual PDF
GX Works3 Operating Manual [SH-081215ENG]	System configuration, parameter settings, and online operations of GX Works3	e-Manual PDF

Point

e-Manual refers to the Mitsubishi Electric FA electronic book manuals that can be browsed using a dedicated tool.

e-Manual has the following features:

- Required information can be cross-searched in multiple manuals.
- Other manuals can be accessed from the links in the manual.
- The hardware specifications of each part can be found from the product figures.
- Pages that users often browse can be bookmarked.
- Sample programs can be copied to an engineering tool.

TERMS

Unless otherwise specified, this manual uses the following terms.

Term	Description
Engineering tool	A tool used for setting up programmable controllers, programming, debugging, and maintenance
Safety control	Machine control by safety programs and safety I/O refresh. When an error occurs, the machine in operation is securely stopped.
Safety CPU	A module that performs both standard control and safety control and is used with a safety function module.
Safety data	Data for which data safety is guaranteed
Safety function	A function provided to protect a person from the hazards of machines
Safety I/O refresh	Inputting safety data from the safety input module to the Safety CPU, as well as outputting safety data from the Safety CPU to the safety output module
Safety program	A program that performs safety control
Safety system	A system that executes the required safety function

GENERIC TERMS AND ABBREVIATIONS

Unless otherwise specified, this manual uses the following generic terms and abbreviations.

Generic term/abbreviation	Description
I/O signal	A generic term for the input signal (X) and output signal (Y)
Safety device	A generic term for the devices that can be used in safety programs <ul style="list-style-type: none">• Safety input (SA\X)• Safety output (SA\Y)• Safety internal relay (SAIM)• Safety link relay (SA\B)• Safety data register (SA\ID)• Safety link register (SA\W)
Safety I/O module	A generic term for the input module (with safety functions) (RX40NC6S-TS) and output module (with safety functions) (RY48PT20S-TS)
Safety I/O signal	A generic term for the safety input signal (SA\X) and safety output signal (SA\Y)
Safety input module	Another name for the input module (with safety functions) (RX40NC6S-TS)
Safety output module	Another name for the output module (with safety functions) (RY48PT20S-TS)

1 PRODUCT LISTS

Input modules

Module name		Input specifications	Current consumption	Weight	Model	Reference
DC input module	Negative common type	Spring clamp terminal block 24VDC, 32 points	260mA	0.21kg	RX40NC6S-TS	 Page 17 RX40NC6S-TS DC input module

Output module

Module name		Output specifications	Current consumption	Weight	Model	Reference
Transistor output module	Source type	Spring clamp terminal block 24VDC, 32 points	250mA	0.21kg	RY48PT20S-TS	 Page 20 RY48PT20S-TS transistor output module

2 PART NAMES

This section describes the part names of the safety I/O module.

Safety input module

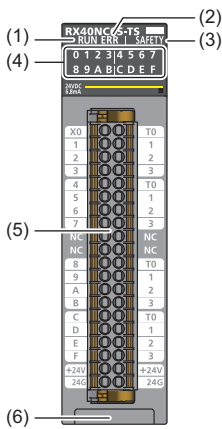

Safety output module

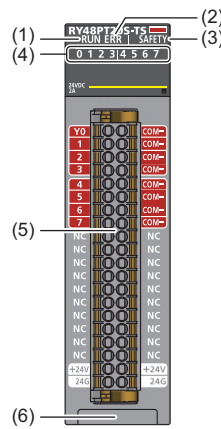

No.	Name	Description	
(1)	RUN LED	Indicates the operating status. On: In operation ^{*1} Off: Major error ^{*2}	
(2)	ERR LED	Indicates the error status of the module. On: Minor error ^{*2} Flashing: Moderate error ^{*2} or major error ^{*2*5} Off: Normal state	
(3)	SAFETY LED	Indicates the safety I/O refresh status. On: Safety I/O refresh in progress Flashing (400ms): Safety module position check in progress ^{*3} Flashing (2s): Waiting for safety module reset ^{*3} Off: Safety I/O refresh stopped	
(4)	I/O status indicator LED	When error points are not indicated	Indicates the ON/OFF status of I/O. On: When the input signal or output signal is on ^{*6} Off: When the input signal or output signal is off
		When error points are indicated	Flashes the error points. On: When the input signal or output signal is on ^{*6} Flashing: Error ^{*4} Off: When the input signal or output signal is off
(5)	I/O terminal block	A spring clamp terminal block to wire the I/O signals.	
(6)	Production information marking	Shows the production information (16 digits) of the module.	

*1 State where no major error is occurring.

*2 When errors have simultaneously occurred due to multiple causes, the error statuses are displayed in the order of error severity (Major error > Moderate error > Minor error).

*3 For details on the displayed contents, refer to the following.

☞ Page 48 Safety Module Validation

*4 Flashing for the error points can be set in the application settings of the module parameter.

☞ Page 41 I/O LED indication setting function on error condition, ☞ Page 46 I/O LED indication setting function on error condition

*5 The points may not flash depending on the failure mode of the hardware.

*6 In the safety operation mode, the status of actual input signals that are externally input is indicated on the input status indicator LED regardless of the input response time. For details on the safety operation mode, refer to the following.

☞ Page 26 Operation mode and state transition

3 SPECIFICATIONS

This chapter describes the general specifications, performance specifications of each module, and function list.

3.1 General Specifications

Item	Specifications					
Operating ambient temperature	0 to 55°C (When an extended temperature range base unit is not used)					
	0 to 60°C (When an extended temperature range base unit is used)					
Storage ambient temperature	-25 to 75°C					
Operating ambient humidity	5 to 95RH, non-condensing					
Storage ambient humidity	5 to 95RH, non-condensing					
Vibration resistance	Compliant with JIS B 3502 and IEC 61131-2	—	Frequency	Constant acceleration	Half amplitude	Sweep count
		Under intermittent vibration	5 to 8.4Hz	—	3.5mm	10 times each in X, Y, and Z directions
			8.4 to 150Hz	9.8m/s ²	—	
		Under continuous vibration	5 to 8.4Hz	—	1.75mm	—
8.4 to 150Hz	4.9m/s ²		—			
Shock resistance	Compliant with JIS B 3502 and IEC 61131-2 (147m/s ² , 3 times each in X, Y, and Z bidirections)					
Operating atmosphere	No corrosive gases ^{*4} , flammable gases, less conductive dust					
Operating altitude ^{*1}	0 to 2000m ^{*5}					
Installation location	Inside a control panel					
Overvoltage category ^{*2}	II or less					
Pollution degree ^{*3}	2 or less					

*1 Do not use or store the programmable controller under pressure higher than the atmospheric pressure of altitude 0m. Doing so may cause malfunction. When using the programmable controller under pressure, please consult your local Mitsubishi representative.

*2 This indicates the section of the power supply to which the equipment is assumed to be connected between the public electrical power distribution network and the machinery within premises. Category II applies to equipment for which electrical power is supplied from fixed facilities. The surge voltage withstand level for up to the rated voltage of 300V is 2500V.

*3 This index indicates the degree to which conductive material is generated in terms of the environment in which the equipment is used. Pollution degree 2 is when only non-conductive pollution occurs. A temporary conductivity caused by condensing must be expected occasionally.

*4 When using the programmable controller in the environment with the corrosive gases, use the special coated products having improved resistance to the environment of a certain degree of corrosive gas concentration specified in IEC 60721-3-3:1994 3C2. For details on the special coated products, please consult your local Mitsubishi representative.

*5 When the programmable controller is used at altitude above 2000m, the withstand voltage performance and the upper limit of the operating ambient temperature decrease. Please consult your local Mitsubishi representative.

3.2 Performance Specifications

RX40NC6S-TS DC input module

Item		Specifications
Number of input points		Single wiring: 16 points, double wiring: 8 points
Rated input voltage		24VDC (ripple ratio: 5% or less) (allowable voltage range: 20.4 to 28.8VDC)
Rated input current		Approx. 6.8mA TYP. (at 24VDC)
ON voltage/ON current		11V or higher/4mA or higher
OFF voltage/OFF current		5V or lower/1.5mA or lower
Input resistance		Approx. 3.2k Ω
Input type		Negative common
Input circuit response time	OFF→ON	0.4ms or less (at 24VDC)
	ON→OFF	0.4ms or less (at 24VDC)
Input response time*1		1ms, 1.5ms, 5ms, 10ms, 20ms, 50ms, 70ms
Input reflection processing time		Input circuit response time + input response time
Safety cycle time		2ms
External power supply*2	Voltage	24VDC (ripple ratio: 5% or less) (allowable voltage range: 20.4 to 28.8VDC)
	Current	140mA (at 24VDC)
	Protection functions	External power supply overvoltage protection function
Withstand voltage		510VAC, 1 minute
Isolation resistance		10M Ω or higher by isolation resistance tester
Noise immunity		Simulator noise 500Vp-p, noise width 1 μ s, noise frequency 25 to 60Hz (noise simulator condition)
Protection degree		IP2X
Wiring method for common		16 points/common
Number of occupied I/O points		32 points (I/O assignment: Input 16 points)
External interface		40 points, 2-piece spring clamp terminal block
Internal current consumption (5VDC)		260mA (TYP. all points ON)
Safety element		Type B, HFT = 1, SC3
Weight		0.21kg

*1 The default value of input response time is 10ms.

*2 To connect to the module, use the power supply that meets the following conditions:

- SELV (Safety Extra Low Voltage): Product with reinforced insulation from the hazardous potential part (60VDC or higher)
- LVD-compliant product
- Output voltage specifications: 24VDC (ripple ratio: 5% or less) (allowable voltage range: 20.4 to 28.8VDC)

External connection

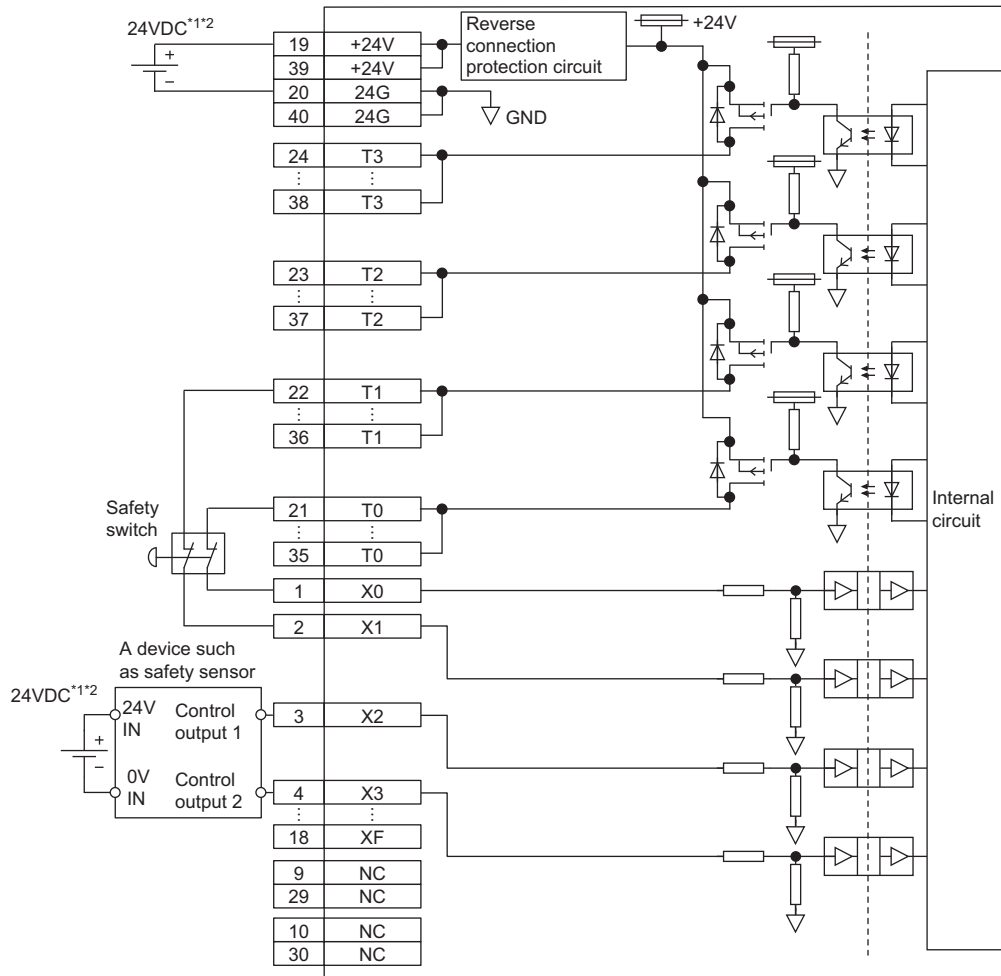

*1 For a power supply to supply 24VDC, use a power supply (SELV power supply) that does not exceed 30VAC (effective value), 42.4V (peak value), or 60VDC and that is compliant with "limited-energy circuit" defined in IEC 61010-1.

*2 For 24VDC wiring, use only wires with an applicable wire size of 1.5mm² (16 AWG).

Input terminal block signal name

Appearance	Terminal number	Signal name	Terminal number	Signal name
	1	X0	21	T0
	2	X1	22	T1
	3	X2	23	T2
	4	X3	24	T3
	5	X4	25	T0
	6	X5	26	T1
	7	X6	27	T2
	8	X7	28	T3
	9	NC	29	NC
	10	NC	30	NC
	11	X8	31	T0
	12	X9	32	T1
	13	XA	33	T2
	14	XB	34	T3
	15	XC	35	T0
	16	XD	36	T1
	17	XE	37	T2
	18	XF	38	T3
	19	+24V	39	+24V
	20	24G	40	24G

Among the terminals with the same signal name, you can choose any terminals since they are internally connected. In addition, NC is reserved. Do not use this terminal.

RY48PT20S-TS transistor output module

Item	SPECIFICATIONS	
Number of output points	Single wiring: 8 points, double wiring: 4 points	
Rated load voltage	24VDC (ripple ratio: 5% or less) (allowable voltage range: 20.4 to 28.8VDC)	
Maximum load current*1	2A/point, 16A/common	
Maximum inrush current	Current is to be limited by the overload protection function.	
Leakage current at OFF	0.1mA or lower	
Maximum voltage drop at ON	DC1.0V	
Protection functions	Output overload protection function	
Double output type	Source + Source type	
Output circuit response time	OFF→ON	0.4ms or less (at 24VDC)
	ON→OFF	0.4ms or less (at 24VDC)
Output reflection processing time	Output circuit response time	
Safety cycle time	2ms	
External power supply*2	Voltage	24VDC (ripple ratio: 5% or less) (allowable voltage range: 20.4 to 28.8VDC)
	Current	59mA (at 24VDC)
	Protection functions	External power supply overvoltage protection function
Surge suppressor	Zener diode	
Withstand voltage	510VAC, 1 minute	
Isolation resistance	10MΩ or higher by isolation resistance tester	
Noise immunity	Simulator noise 500Vp-p, noise width 1μs, noise frequency 25 to 60Hz (noise simulator condition)	
Protection degree	IP2X	
Wiring method for common	8 points/common	
Number of occupied I/O points	32 points (I/O assignment: Output 16 points)	
External interface	40 points, 2-piece spring clamp terminal block	
Internal current consumption (5VDC)	250mA (TYP. all points ON)	
Safety element	Type B, HFT = 1, SC3	
Weight	0.21kg	

*1 When the common current exceeds 8A, connect two +24V terminals and two 24G terminals. The total current consumption of the output current and the external power supply should be 16A/common or less.

*2 To connect to the module, use the power supply that meets the following conditions:

- SELV (Safety Extra Low Voltage): Product with reinforced insulation from the hazardous potential part (60VDC or higher)
- LVD-compliant product
- Output voltage specifications: 24VDC (ripple ratio: 5% or less) (allowable voltage range: 20.4 to 28.8VDC)

Derating chart

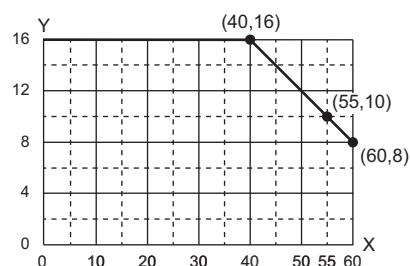

X: Ambient temperature (°C)*1

Y: Common current (A/common)

*1 If the ambient temperature exceeds 55°C, the module can be used only when it is mounted on the extended temperature range base unit.

External connection

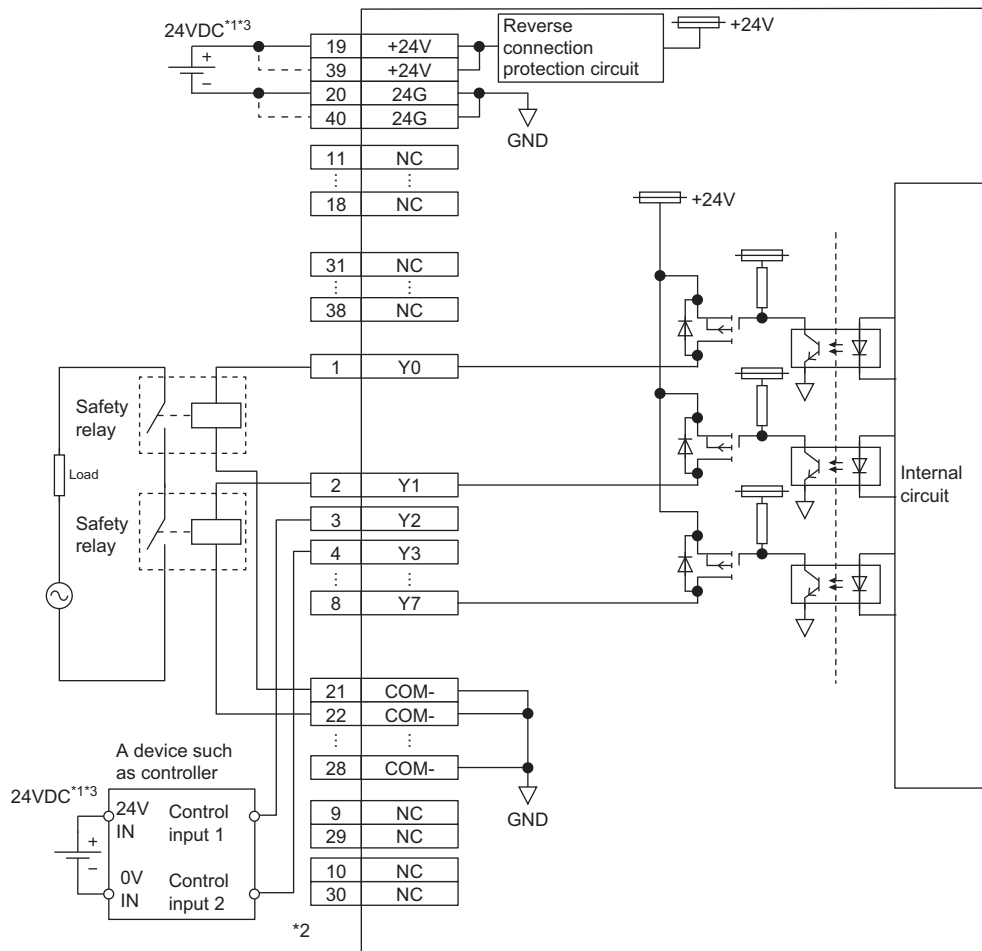

- *1 For a power supply to supply 24VDC, use a power supply (SELV power supply) that does not exceed 30VAC (effective value), 42.4V (peak value), or 60VDC and that is compliant with "limited-energy circuit" defined in IEC 61010-1.
- *2 The Δ mark on the rating plate indicates that wires with an appropriate temperature rating (105°C or greater) must be used for wiring.
- *3 For 24VDC wiring, use only wires with an applicable wire size of 1.5mm² (16 AWG).

■ Output terminal block signal name

Appearance	Terminal number	Signal name	Terminal number	Signal name
	1	Y0	21	COM-
	2	Y1	22	COM-
	3	Y2	23	COM-
	4	Y3	24	COM-
	5	Y4	25	COM-
	6	Y5	26	COM-
	7	Y6	27	COM-
	8	Y7	28	COM-
	9	NC	29	NC
	10	NC	30	NC
	11	NC	31	NC
	12	NC	32	NC
	13	NC	33	NC
	14	NC	34	NC
	15	NC	35	NC
	16	NC	36	NC
	17	NC	37	NC
	18	NC	38	NC
	19	+24V	39	+24V
	20	24G	40	24G

Among the terminals with the same signal name, you can choose any terminals since they are internally connected. In addition, NC is reserved. Do not use this terminal.

Safety response time

The following shows the calculation formula for the maximum value of the safety response time, including error detection, for the safety I/O module.

■ Safety input module → Safety output module

The following indicates the time from when a signal is input to the safety input module until the output of the safety output module is turned on or off.

Sought variable	Calculation formula
Maximum value	$(SC_{cpu} \times 3) + (SC_{io} \times 4.5) + (RT \times 2) + Rin + Rout$

Symbols in the calculation formula are as shown below.

Symbol	Description
SC _{cpu}	Safety cycle time of the Safety CPU ^{*1}
SC _{io}	Safety cycle time of the safety I/O module ^{*2*3}
RT	Safety I/O refresh timeout time ^{*4}
Rin	Input reflection processing time (input circuit response time + input response time) ^{*2}
Rout	Output reflection processing time (output circuit response time) ^{*3}

*1 For details, refer to the following.

📖 MELSEC iQ-R CPU Module User's Manual (Application)

*2 For details, refer to the following.

📖 Page 17 RX40NC6S-TS DC input module

*3 For details, refer to the following.

📖 Page 20 RY48PT20S-TS transistor output module

*4 The safety I/O refresh timeout time can be set in "Basic setting" in the "Module Parameter" window.

📖 Page 40 Safety I/O refresh monitoring time

■ Safety CPU ← Safety input module

The following indicates the time from when a signal is input to the safety input module until the safety device of the Safety CPU is turned on or off.

Sought variable	Calculation formula
Maximum value	$(SC_{cpu} \times 2) + (SC_{io} \times 2) + RT + Rin$

Symbols in the calculation formula are as shown below.

Symbol	Description
SC _{cpu}	Safety cycle time of the Safety CPU ^{*1}
SC _{io}	Safety cycle time of the safety input module ^{*2}
RT	Safety I/O refresh timeout time ^{*3}
Rin	Input reflection processing time (input circuit response time + input response time) ^{*2}

*1 For details, refer to the following.

📖 MELSEC iQ-R CPU Module User's Manual (Application)

*2 For details, refer to the following.

📖 Page 17 RX40NC6S-TS DC input module

*3 The safety I/O refresh timeout time can be set in "Basic setting" in the "Module Parameter" window.

📖 Page 40 Safety I/O refresh monitoring time

■ Safety CPU → Safety output module

The following indicates the time from when the safety device of the Safety CPU is turned on or off until the output of the safety output module is turned on or off.

Sought variable	Calculation formula
Maximum value	$SC_{cpu}+(SC_{io}\times 2.5)+RT+R_{out}$

Symbols in the calculation formula are as shown below.

Symbol	Description
SC_{cpu}	Safety cycle time of the Safety CPU ^{*1}
SC_{io}	Safety cycle time of the safety output module ^{*2}
RT	Safety I/O refresh timeout time ^{*3}
R_{out}	Output reflection processing time (output circuit response time) ^{*2}

*1 For details, refer to the following.

 MELSEC iQ-R CPU Module User's Manual (Application)

*2 For details, refer to the following.

 Page 20 RY48PT20S-TS transistor output module

*3 The safety I/O refresh timeout time can be set in "Basic setting" in the "Module Parameter" window.

 Page 45 Safety I/O refresh monitoring time

3.3 Function List

This section describes the function list, operation modes, and state transition of the safety I/O module.

Function list

The table below lists the functions of the safety I/O module.

○: Available, —: Not available

Item		Description	Applicable module		Reference
			Safety input module	Safety output module	
Safety I/O refresh function		Periodically communicates I/O data between the safety I/O module and the Safety CPU by using safety protocols.	○	○	☞ Page 54 Safety I/O Refresh Function
Safety input function	Input wiring selection function	Selects double wiring or single wiring for the input wiring.	○	—	☞ Page 59 Input wiring selection function
	Input response time setting function	Reduces incorrect inputs caused by noise of input signals. Sets the time taken from when an external input turns on/off until when the input signal is detected in the safety input module.	○	—	☞ Page 62 Input response time setting function
Safety output function	Output wiring selection function	Selects double wiring or single wiring for the output wiring.	—	○	☞ Page 63 Output wiring selection function
Input diagnostic function	Double input discrepancy detection function	Discriminates failures by monitoring the discrepancy state of doubled input signals.	○	—	☞ Page 65 Double input discrepancy detection function
	Input dark test function	Outputs test pulses to turn off the inputs that are on and diagnoses contacts including external devices for failure.	○	—	☞ Page 68 Input dark test function
	Internal input dark test function	Outputs test pulses to the internal input circuit of the safety input module to detect a circuit-fixing failure. The test pulses turn off the inputs that are on to detect the failure.	○	—	☞ Page 70 Internal input dark test function
Output diagnostic function	Output dark test function	Outputs test pulses to turn off the outputs that are on and diagnoses the internal circuit for failure.	—	○	☞ Page 71 Output dark test function
	Output read-back function	Reads back output results and diagnoses whether the output signals are correctly on or off.	—	○	☞ Page 72 Output read-back function
Protection functions		Protect other modules of the safety system from effects due to overvoltage and overcurrent.	○	○	☞ Page 73 Protection Functions
Operation setting function at detection of external power supply voltage error		Selects whether to continue safety I/O refresh or stop it when an external power supply voltage error occurs.	○	○	☞ Page 74 Operation Setting Function at Detection of External Power Supply Voltage Error
I/O LED indication setting function on error condition		Selects the indication method of the I/O status indicator LED when an error occurs.	○	○	☞ Page 80 I/O LED Indication Setting Function on Error Condition

Operation mode and state transition

The following describes the operation mode/state and transition conditions of the safety I/O module.

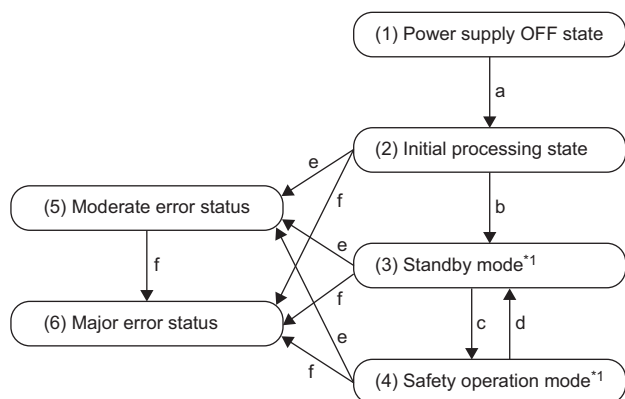

*1 This includes a minor error status.

■ Operation mode/state

No.	Operation mode/state	Description
(1)	Power supply OFF state	The power supply is not turned on. Wire the module at this state.
(2)	Initial processing state	The initial processing is performed at this state.
(3)	Standby mode	The safety functions of the safety I/O module do not operate at this state.
(4)	Safety operation mode	The safety functions of the safety I/O module operate at this state.
(5)	Moderate error status	A moderate error has occurred.
(6)	Major error status	A major error or watchdog timer error has occurred.

■ Transition condition

Symbol	Transition condition
a	When the module is powered on
b	When the initial processing is completed successfully
c	When the safety I/O refresh with the Safety CPU starts after safety module validation is executed
d	When the safety I/O refresh stops
e	When a moderate error occurs
f	When a major error or watchdog timer error occurs

4 PROCEDURES BEFORE OPERATION

4.1 Procedures Before Operation

This chapter describes the procedures before operation.

1. Mounting a module

Mount the safety I/O module in any desired configuration.

☞ Page 29 System Configuration

2. Wiring

Perform wiring of external power supply and external devices to the safety I/O module.

☞ Page 32 Wiring

3. Adding a module

Add the safety I/O module to a module configuration by using the engineering tool. For details, refer to the following.

📖 GX Works3 Operating Manual

4. Parameter setting

Set up the parameters of the safety I/O module by using the engineering tool.

☞ Page 38 PARAMETER SETTINGS

5. Safety module validation

Enable the parameter settings of the safety I/O module.

☞ Page 48 Safety Module Validation

4.2 Module Replacement Procedure

This section describes the module replacement procedure.

1. Powering off the system

Turn off the programmable controllers including the safety I/O module and external power supply.

2. Removing the I/O terminal block

Remove the I/O terminal block of the safety I/O module to be replaced with wires connected.

 Page 32 Installing and removing the I/O terminal block

3. Removing the safety I/O module to be replaced

Remove the safety I/O module to be replaced from the base unit.

4. Mounting the new module

Mount the new safety I/O module onto the base unit.

5. Connecting the I/O terminal block

Connect the removed I/O terminal block with wires to the new module.

 Page 32 Wiring

6. Powering on the system

Turn on the programmable controller system including the safety I/O module and external power supply.

7. Safety module validation

Enable the parameter settings of the new safety I/O module.

 Page 48 Safety Module Validation

5 SYSTEM CONFIGURATION

5.1 System Configuration

System configuration example when safety I/O modules are used

The following figure shows an example of the system configuration when safety I/O modules are used.

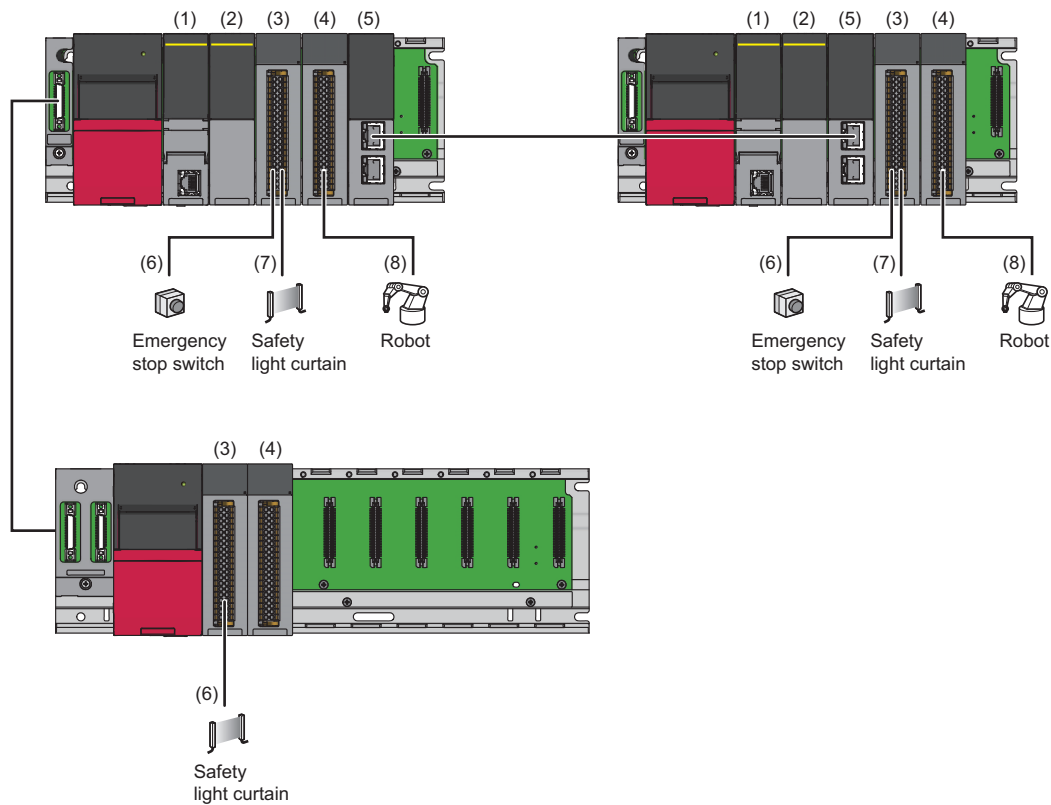

- (1) Safety CPU
- (2) Safety function module
- (3) Safety input module
- (4) Safety output module
- (5) Master/local module
- (6) Input signal (double wiring)
- (7) Input signal (single wiring)
- (8) Output signal

5.2 Applicable Systems

Applicable modules and the number of mountable modules

The following table shows applicable modules and the number of mountable modules.

Applicable module		Firmware version	Number of mountable modules
Safety CPU	<ul style="list-style-type: none">• R08SF CPU• R16SF CPU• R32SF CPU• R120SF CPU	"31" or later	63 pieces maximum
Safety function module	R6SFM	"31" or later	

Point

- Use the Safety CPU and the safety function module as a pair.
- If a CPU module other than the ones listed above and the safety I/O module are used together, an unsupported CPU error (error code: 3010H) will occur on the safety I/O module.

Connectable base slots

Modules can be mounted on any I/O slot of the base unit. However, power capacity may be insufficient depending on the combination with other mounted modules and the number of mounted modules.

Compatible software package

To ensure compatibility of the software version, always update GX Works3 to the latest version.

Online module change

Online module change is not supported.

Combinations of the safety I/O module and other modules

When using the safety I/O module together with other modules, ensure that all the modules meet Class III or SELV.

5.3 Safety Standards

This product complies with the following standards.

Standard

EN ISO 13849-1: 2015
EN ISO 13849-2: 2012
EN 61508 Parts 1-7: 2010
EN 61131-2: 2007 (clauses 6.1-6.3, 8)
IEC 61131-2: 2017 (clauses 5.2.1, 5.3, 7)
EN 61000-6-7: 2015

Point

The revisions of the applicable standards are subject to an update. For the latest information, check EC-Type-Examination Certificate on the TUV Rheinland website (www.tuv.com).

This product can be used with the applications that comply with the following standards.

Standard

EN ISO 13849-1: 2015 (PL e, Category 4)
EN 61508 Parts 1-7: 2010 (SIL3)
EN IEC 62061: 2021
IEC 61511-1: 2016+Corr.1: 2016+AMD1: 2017 (SIL3)
NFPA 79: 2021
EN 60204-1: 2018
IEC 61131-2: 2017

Point

The revisions of the above standards are subject to an update. For the latest information, check EC-Type-Examination Certificate on the TUV Rheinland website (www.tuv.com).

6 INSTALLATION AND WIRING

6.1 Installation of Safety I/O Module

For installation of the safety I/O module, refer to the following.

📖 MELSEC iQ-R Module Configuration Manual

6.2 Wiring

Wire to be used

The following table describes the wire to be connected to the terminal block for the external power supply and I/O terminal block.

Diameter	Type	Material	Temperature rating
22 to 16 AWG	Stranded wire	Copper	105°C or greater

Installing and removing the I/O terminal block

The following describes the procedures for installing and removing the I/O terminal block.

■ Lock and release lever positions

To make it easy to install and remove the I/O terminal block, a three-stage positioning stopper is attached so that the lever does not freely turn around.

When installing or removing the terminal block, move the lever to the lock or release lever position.

■ Figure viewed from the module top surface: When pulling the I/O terminal block

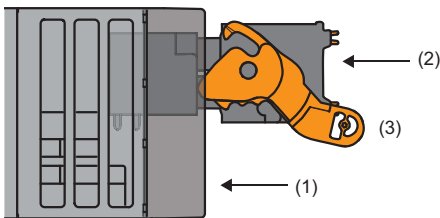

1. Release lever position

This lever position shows the state in which the I/O terminal block has been completely pulled out from the safety I/O module. Turn from the lock lever position to the release lever position and lift the I/O terminal block from the safety I/O module.

■ Figure viewed from the module top surface: When insertion of the I/O terminal block has been completed

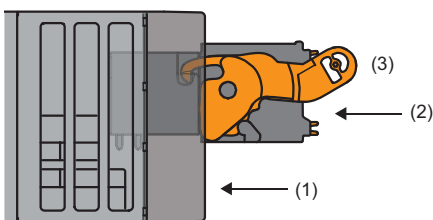

2. Lock lever position

This lever position shows the state in which the I/O terminal block completely fits the safety I/O module. Check the lock lever position and pull the I/O terminal block lightly to check that the safety I/O module completely fits the I/O terminal block.

- (1) Front part of a module
- (2) I/O terminal block
- (3) Lever position

■ Removal procedure



Turn the lever to the release lever position and remove the I/O terminal block from the safety I/O module.

■ Installation procedure

Move the lever to the lock lever position and push the I/O terminal block. When the I/O terminal block is fully pushed in, the hook of the lever hangs on the safety I/O module and fits the I/O terminal block.

The terminal block can be inserted with the lever locations other than the lock lever position. After insertion, check that the lever is in the lock lever position.

Precautions for external wiring

- Use a ferrule for the wiring to the terminal block. If a stripped wire is inserted to a wire insertion opening, the wire cannot be clamped securely.
- Use a crimping tool to attach a ferrule to a wire. ( Page 33 List of ferrules)
- When inserting a ferrule, ensure that the size and orientation of the ferrule are correct to prevent the terminal from getting stuck in or the terminal block damage. The shape of the ferrule after processing (the size includes an error in processing) should be smaller than the wire insertion opening. ( Page 35 Connecting the cable)

List of ferrules

The following table lists recommended ferrules. Use the crimping tool whose manufacturer is the same as that of the ferrules used.

Product name		Model	Applicable wire size*1	Length of peeling	Crimping tool	Contact
Ferrule	With insulation sleeve	AI 0.34-10TQ	0.34mm ²	12mm	CRIMPFOX6	PHOENIX CONTACT GmbH & Co. KG
		AI 0.5-10WH	0.5mm ²	13mm		
		AI 0.75-10GY	0.75mm ²	13mm		
	Without insulation sleeve	A 0.5-10	0.5mm ²	10mm		
		A 0.75-10	0.75mm ²	10mm		
		A 1-10	1.0mm ²	10mm		
		A 1.5-10	1.5mm ²	10mm		

*1 When using a terminal with an insulation sleeve, use a maximum of 0.75mm². When using a terminal without an insulation sleeve, use a maximum of 1.5mm².

Processing method of the cable terminal

1. Strip the cable from the tip.

- For how long the cable should be stripped, follow the specifications of the ferrule used.
- Stripping the cable too long may cause electric shock or short circuit between adjacent terminals because the conductive part sticks out of the I/O terminal block.
- Stripping the cable too short may cause a poor contact to the spring clamp terminal part.

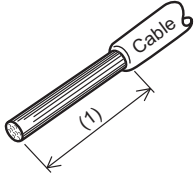

(1) Stripped part

2. Connect a ferrule to the exposed area of the cable.

- Use a ferrule with suitable size for the wire.
- To crimp a ferrule, use a proper crimping tool.
- Push in the cable so that approx. 0 to 0.5mm of the wire tip protrudes from the sleeve.

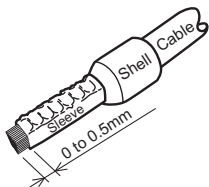

3. After crimping, check the exterior of the ferrule.

Do not use a ferrule that is damaged or not properly crimped.

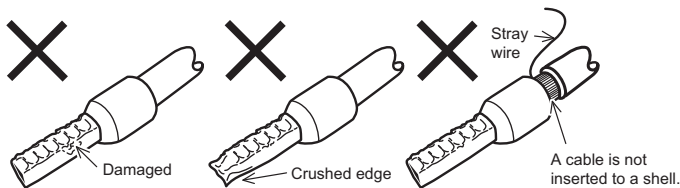

Connecting the cable

Insert a wire onto which a ferrule is crimped into the wire insertion opening and push the wire. After that, pull the cable lightly toward you, to check that it is securely clamped.

For the correct terminal orientation to insert it, refer to the figure below.

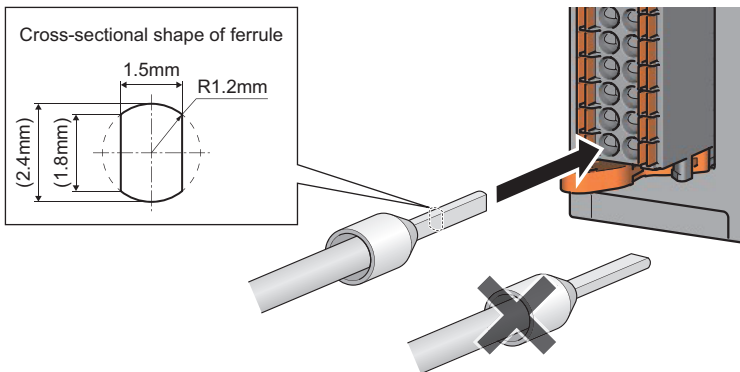

Disconnecting the cable

Push the open/close button of the wire to be disconnected with a tool dedicated to the removal. Pull out the wire with the open/close button pushed.

6

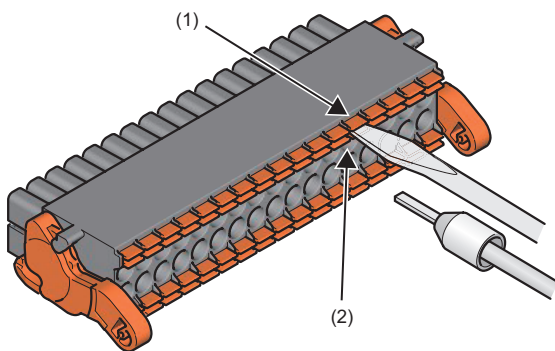

- (1) Open/close button
- (2) Wire insertion opening

Use a tool with the shape below to disconnect the wire.

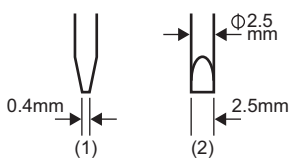

- (1) Side view
- (2) Front view

■ Tool dedicated to the removal

The following is a recommended tool to disconnect the wire.

Product name	Model	Contact
Tool dedicated to the removal	SZF 0-0,4X2,5	PHOENIX CONTACT GmbH & Co. KG

Wiring of the external power supply

If the external power supply is off when the power supply to the programmable controller is turned on, an external power supply voltage error (error code: 3600H or 1A00H) occurs. Turn on the external power supply before turning on the programmable controller.

The error code that occurs is determined based on "Operation setting of external power supply voltage error detection" in "Application setting". For details, refer to the following.

☞ Page 74 Operation Setting Function at Detection of External Power Supply Voltage Error

Precautions for wiring the safety I/O module to safety devices

When wiring the input part

■Combination of input terminals for double input

For double input, the input terminals can be used only in the combinations shown below. They cannot be used in combinations other than the following.

Combination of input terminals for double input							
X0, X1	X2, X3	X4, X5	X6, X7	X8, X9	XA, XB	XC, XD	XE, XF

■Combination of test pulse output terminals for double input

For double input, the test pulse output terminals and input terminals can be used only in the combinations shown below. They cannot be used in combinations other than the following.

Combination of test pulse output terminals for double input	
Test pulse output terminal	Input terminal
T0	X0, X4, X8, XC
T1	X1, X5, X9, XD
T2	X2, X6, XA, XE
T3	X3, X7, XB, XF

■Precautions

To satisfy SIL3, Category 4 PLe, use input devices with normally closed contacts. Inputs using the devices with normally open contacts do not satisfy SIL3, Category 4 PLe.

When wiring the output part

For double output, the output terminals can be used only in the combinations shown below. They cannot be used in combinations other than the following.

Combination of output terminals for double output			
Y0, Y1	Y2, Y3	Y4, Y5	Y6, Y7

Wiring test for external output

When the safety operation mode of the Safety CPU is test mode, a wiring test for external output can be executed by using the current value change function of the engineering tool to change the current value of the safety device. For details on the current value change function, refer to the following.

 GX Works3 Operating Manual

Precautions

- When the safety operation mode of the Safety CPU is safety mode, the current value of the safety device cannot be changed by using the current value change function of the engineering tool.
- When the safety operation mode of the Safety CPU is in test mode, the safety output is refreshed instead of being force cleared, even when the operating status of the Safety CPU is in the STOP state.

7 PARAMETER SETTINGS

This chapter describes the parameter settings of the safety I/O modules.

Parameter Setting Procedure

1. Add the safety I/O module to the setting in the engineering tool.

 [Navigation window] ⇒ [Parameter] ⇒ [Module Information] ⇒ Right-click ⇒ [Add New Module]

2. The parameter setting consists of three items: basic settings, application settings, and refresh settings. Select these items from the tree window below to set them.

 [Navigation window] ⇒ [Parameter] ⇒ [Module Information] ⇒ Select the safety I/O module

3. Write the parameter setting into the Safety CPU using the engineering tool.

 [Online] ⇒ [Write to PLC]

4. Reset the Safety CPU or turn off and on the power to reflect the setting.

5. Perform the safety module validation.

 Page 48 Safety Module Validation

Point

When writing parameter settings to a Safety CPU, simultaneously write "System Parameter/CPU Parameter (Standard/Safety)" and "Module Parameter (Standard/Safety)".

7.1 Parameter Setting of the RX40NC6S-TS

Basic setting

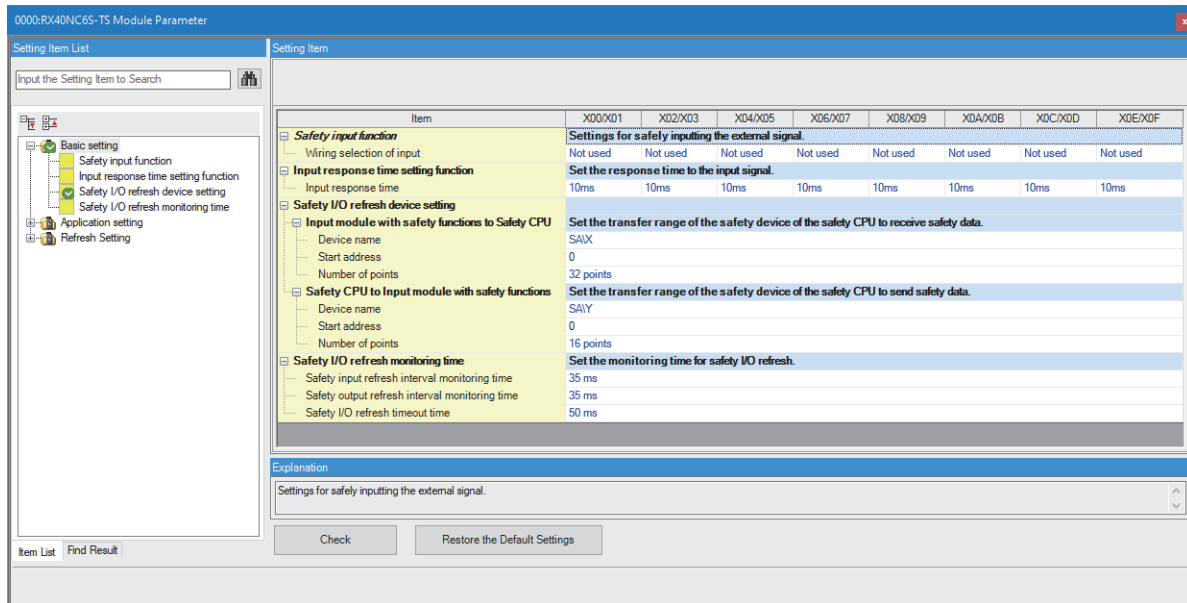

Safety input function

This setting is used to safely input external signals.

Item	Description	Setting range
Wiring selection of input	Set the input wiring in units of 2 input points.	<ul style="list-style-type: none"> • Not used • Double wiring (NC/NC) • Single • Xn: Single Xn+1: Not used*¹ • Xn: Not used Xn+1: Single*¹ (Default: Not used)

*1 n is an even number from 0 to E.

Input response time setting function

Set the response time for the input signal.

Item	Description	Setting range
Input response time	To prevent malfunction of the input signal, set the sensitivity to react to the input signal in units of 2 input points.	<ul style="list-style-type: none"> • 1.0ms • 1.5ms • 5ms • 10ms • 20ms • 50ms • 70ms (Default: 10ms)

Safety I/O refresh device setting

Set the transfer range of the safety device of the Safety CPU that sends and receives safety data.

Item		Description	Setting range
Input module with safety functions to Safety CPU	Device name	Set the device name of the Safety CPU that receives safety data.	<ul style="list-style-type: none"> • SAIX • SAIM • SAIB • SAID • SAIW (Default: SAIX)
	Start address	Set the start address of the device of the Safety CPU that receives safety data.	Safety device range of the Safety CPU ^{*1} (Example: 0 to 1FE0 when the number of device points for SAIX is 8K points) (Default: Empty)
	Number of points	Set the number of device points of the Safety CPU that receives safety data.	<ul style="list-style-type: none"> ■Bit device (SAIX, SAIM, SAIB) <ul style="list-style-type: none"> • 16 points • 32 points ■Word device (SAID, SAIW) <ul style="list-style-type: none"> • 1 point • 2 points (Default: 32 points)
Safety CPU to Input module with safety functions	Device name	Set the device name of the Safety CPU that sends safety data.	<ul style="list-style-type: none"> • SAIX • SAIM • SAIB • SAID • SAIW (Default: SAIX)
	Start address	Set the start address of the device of the Safety CPU that sends safety data.	Safety device range of the Safety CPU ^{*1} (Example: 0 to 1FE0 when the number of device points for SAIX is 8K points) (Default: Empty)
	Number of points	Set the number of device points of the Safety CPU that sends safety data.	<ul style="list-style-type: none"> ■Bit device (SAIX, SAIM, SAIB) <ul style="list-style-type: none"> • 16 points • 32 points ■Word device (SAID, SAIW) <ul style="list-style-type: none"> • 1 point • 2 points (Default: 16 points)

*1 The setting range varies depending on the number of safety device points to be set with the CPU parameter of the Safety CPU. For the setting of the number of safety device points, refer to the following.

 MELSEC iQ-R CPU Module User's Manual (Application)

Safety I/O refresh monitoring time

Set the monitoring time for safety I/O refresh.

Item	Description	Setting range
Safety input refresh interval monitoring time	Set the safety input refresh interval monitoring time that the Safety CPU monitors to detect safety I/O refresh errors.	4ms to 1000ms (Default: 35ms)
Safety output refresh interval monitoring time	Set the safety output refresh interval monitoring time that the safety I/O module monitors to detect safety I/O refresh errors.	4ms to 1000ms (Default: 35ms)
Safety I/O refresh timeout time	Set the safety I/O refresh timeout time that the safety I/O module and the Safety CPU monitor to detect safety I/O refresh errors.	6ms to 2000ms (Default: 50ms)

Application setting

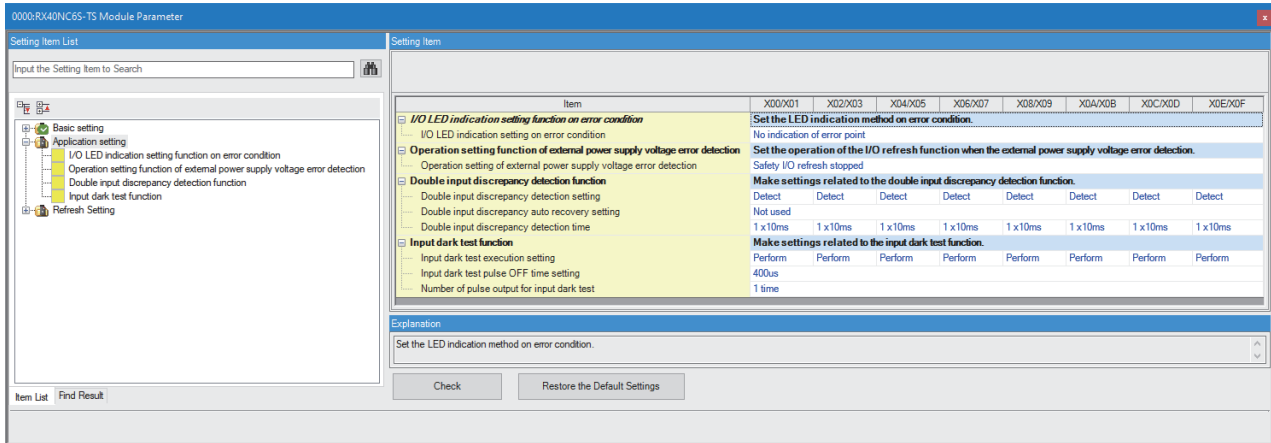

I/O LED indication setting function on error condition

Set the I/O LED indication method on error condition.

Item	Description	Setting range
I/O LED indication setting on error condition	Set the LED indication method on error condition.	<ul style="list-style-type: none"> No indication of error point Indication of error point (Default: No indication of error point)

7

Operation setting function of external power supply voltage error detection

Set the operation of the safety I/O refresh function when an external power supply voltage error occurs.

Item	Description	Setting range
Operation setting of external power supply voltage error detection	Set the operation of the safety I/O refresh function when an external power supply voltage error occurs.	<ul style="list-style-type: none"> Safety I/O refresh stopped Safety I/O refresh continues (Without output interlock) Safety I/O refresh continues (With output interlock) (Default: Safety I/O refresh stopped)

Double input discrepancy detection function

Set the items regarding the double input discrepancy detection function.

Item	Description	Setting range
Double input discrepancy detection setting	Set whether to detect double input discrepancy in units of 2 input points.	<ul style="list-style-type: none"> Detect Do not detect (Default: Detect)
Double input discrepancy auto recovery setting	Set whether to recover the normal state automatically when a double input discrepancy detection error has occurred and the error factor has been removed.	<ul style="list-style-type: none"> Not used Used (Default: Not used)
Double input discrepancy detection time	Set the double input discrepancy allowed time in units of 2 input points. (Unit: ×10ms)	1 to 6000 (Default: 1)

Input dark test function

Set the items regarding the input dark test function.

Item	Description	Setting range
Input dark test execution setting	Set whether to perform the input dark test function in units of 2 input points.	<ul style="list-style-type: none">• Perform• Do not perform (Default: Perform)
Input dark test pulse OFF time setting	Set the width of the OFF pulses that the terminals T0 to T3 output.	<ul style="list-style-type: none">• 400μs• 1ms• 2ms (Default: 400 μ s)
Number of pulse output for input dark test	Set the number of OFF pulses for input dark test diagnostics.	<ul style="list-style-type: none">• 1 time• 2 times• 3 times (Default: 1 time)

Refresh Setting

Set the refresh timing of the refresh destination specified.

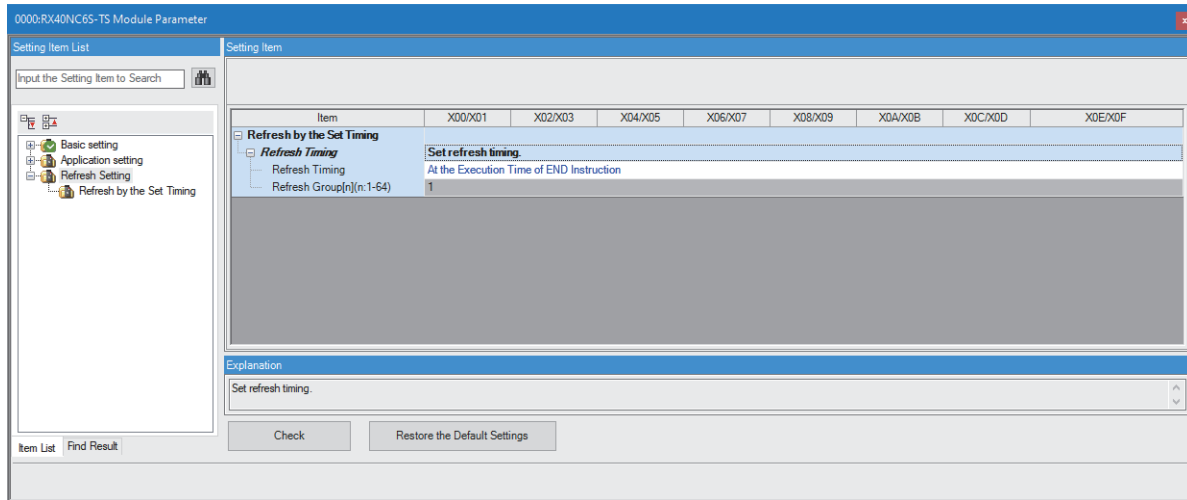

Refresh Timing

Set the refresh timing.

Item	Description	Setting range
Refresh Timing	<p>Set the refresh timing.</p> <ul style="list-style-type: none"> At the Execution Time of END Instruction: Refresh takes place at the time of the END processing of the Safety CPU. At the Execution Time of Specified Program: Refresh takes place at the time of the execution of the program with the group number specified in "Refresh Group Setting" of "CPU Parameter". For details on the setting, refer to the following. <p> MELSEC iQ-R CPU Module User's Manual (Application)</p>	<ul style="list-style-type: none"> At the Execution Time of END Instruction At the Execution Time of Specified Program <p>(Default: At the Execution Time of END Instruction)</p>
Refresh Group[n](n: 1-64)	<p>Set the group number of the program to be refreshed when "Refresh Timing" is set to "At the Execution Time of Specified Program".</p>	<p>1 to 64 (Default: 1)</p>

Point

This item is applicable only to I/O signals (X/Y) and is not applicable to safety I/O signals (SA\X, SA\Y). For details on the safety I/O refresh timing, refer to the following.
 MELSEC iQ-R CPU Module User's Manual (Application)

7.2 Parameter Setting of the RY48PT20S-TS

Basic setting

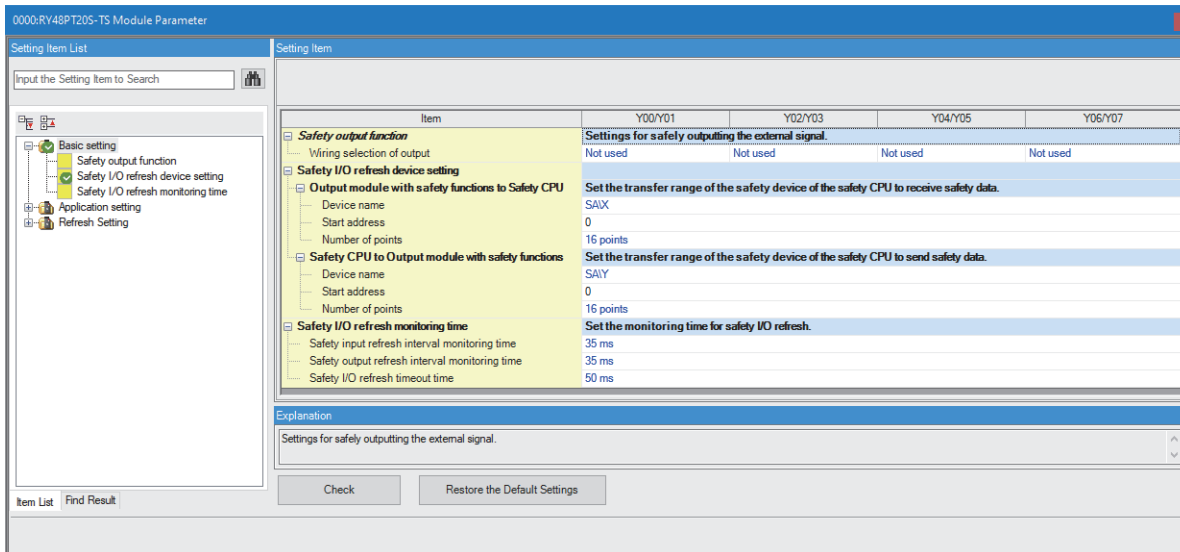

Safety output function

This setting is used to safely output external signals.

Item	Description	Setting range
Wiring selection of output	Set the output wiring in units of 2 output points of.	<ul style="list-style-type: none"> • Not used • Double wiring (Source/Source) • Single • Yn: Single Yn+1: Not used^{*1} • Yn: Not used Yn+1: Single^{*1} (Default: Not used)

*1 n is an even number from 0 to 6.

Safety I/O refresh device setting

Set the transfer range of the safety device of the Safety CPU that sends and receives safety data.

Item		Description	Setting range
Output module with safety functions to Safety CPU	Device name	Set the device name of the Safety CPU that receives safety data.	<ul style="list-style-type: none"> • SAIX • SAIM • SAIB • SAID • SAIW (Default: SAIX)
	Start address	Set the start address of the device of the Safety CPU that receives safety data.	Safety device range of the Safety CPU ^{*1} (Example: 0 to 1FE0 when the number of device points for SAIX is 8K points) (Default: Empty)
	Number of points	Set the number of device points of the Safety CPU that receives safety data.	<ul style="list-style-type: none"> ■Bit device (SAIX, SAIM, SAIB) <ul style="list-style-type: none"> • 16 points • 32 points ■Word device (SAID, SAIW) <ul style="list-style-type: none"> • 1 point • 2 points (Default: 16 points)
Safety CPU to Output module with safety functions	Device name	Set the device name of the Safety CPU that sends safety data.	<ul style="list-style-type: none"> • SAIX • SAIM • SAIB • SAID • SAIW (Default: SAIX)
	Start address	Set the start address of the device of the Safety CPU that sends safety data.	Safety device range of the Safety CPU ^{*1} (Example: 0 to 1FE0 when the number of device points for SAIX is 8K points) (Default: Empty)
	Number of points	Set the number of device points of the Safety CPU that sends safety data.	<ul style="list-style-type: none"> ■Bit device (SAIX, SAIM, SAIB) <ul style="list-style-type: none"> • 16 points • 32 points ■Word device (SAID, SAIW) <ul style="list-style-type: none"> • 1 point • 2 points (Default: 16 points)

*1 The setting range varies depending on the number of safety device points to be set with the CPU parameter of the Safety CPU. For the setting of the number of safety device points, refer to the following.

 MELSEC iQ-R CPU Module User's Manual (Application)

Safety I/O refresh monitoring time

Set the monitoring time for safety I/O refresh.

Item	Description	Setting range
Safety input refresh interval monitoring time	Set the safety input refresh interval monitoring time that the Safety CPU monitors to detect safety I/O refresh errors.	4ms to 1000ms (Default: 35ms)
Safety output refresh interval monitoring time	Set the safety output refresh interval monitoring time that the safety I/O module monitors to detect safety I/O refresh errors.	4ms to 1000ms (Default: 35ms)
Safety I/O refresh timeout time	Set the safety I/O refresh timeout time that the safety I/O module and the Safety CPU monitor to detect safety I/O refresh errors.	6ms to 2000ms (Default: 50ms)

Application setting

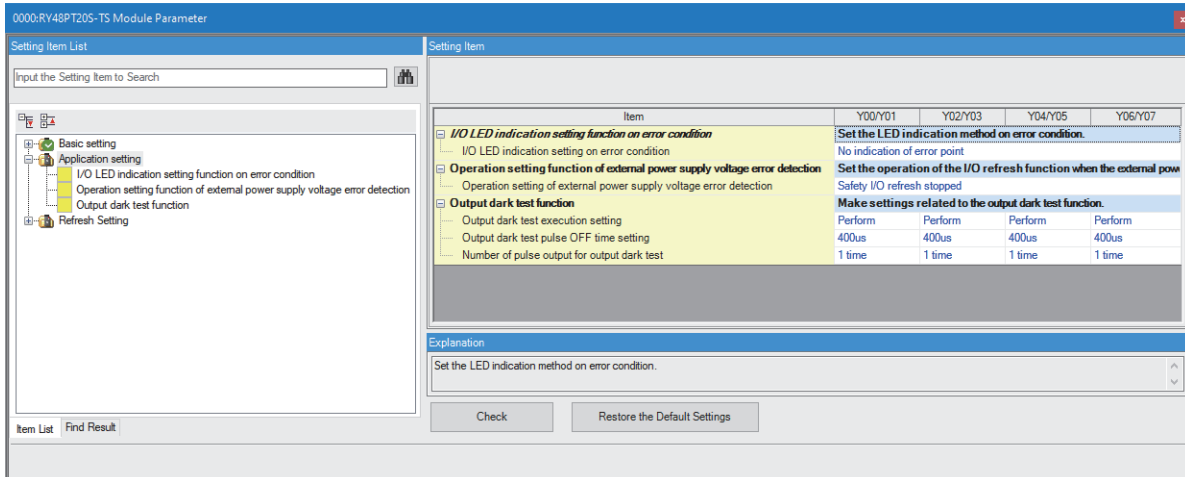

I/O LED indication setting function on error condition

Set the I/O LED indication method on error condition.

Item	Description	Setting range
I/O LED indication setting on error condition	Set the LED indication method on error condition.	<ul style="list-style-type: none"> No indication of error point Indication of error point (Default: No indication of error point)

Operation setting function of external power supply voltage error detection

Set the operation of the safety I/O refresh function when an external power supply voltage error occurs.

Item	Description	Setting range
Operation setting of external power supply voltage error detection	Set the operation of the safety I/O refresh function when an external power supply voltage error occurs.	<ul style="list-style-type: none"> Safety I/O refresh stopped Safety I/O refresh continues (Without output interlock) Safety I/O refresh continues (With output interlock) (Default: Safety I/O refresh stopped)

Output dark test function

Set the items regarding the output dark test function.

Item	Description	Setting range
Output dark test execution setting	Set whether to perform the output dark test function in units of 2 output points.	<ul style="list-style-type: none"> Perform Do not perform (Default: Perform)
Output dark test pulse OFF time setting	Set the width of OFF pulses used for an output dark test in units of 2 output points.	<ul style="list-style-type: none"> 400μs 1ms 2ms (Default: 400μs)
Number of pulse output for output dark test	Set the number of OFF pulses for output dark test diagnostics in units of 2 output points.	<ul style="list-style-type: none"> 1 time 2 times 3 times (Default: 1 time)

Refresh Setting

Set the refresh timing of the refresh destination specified.

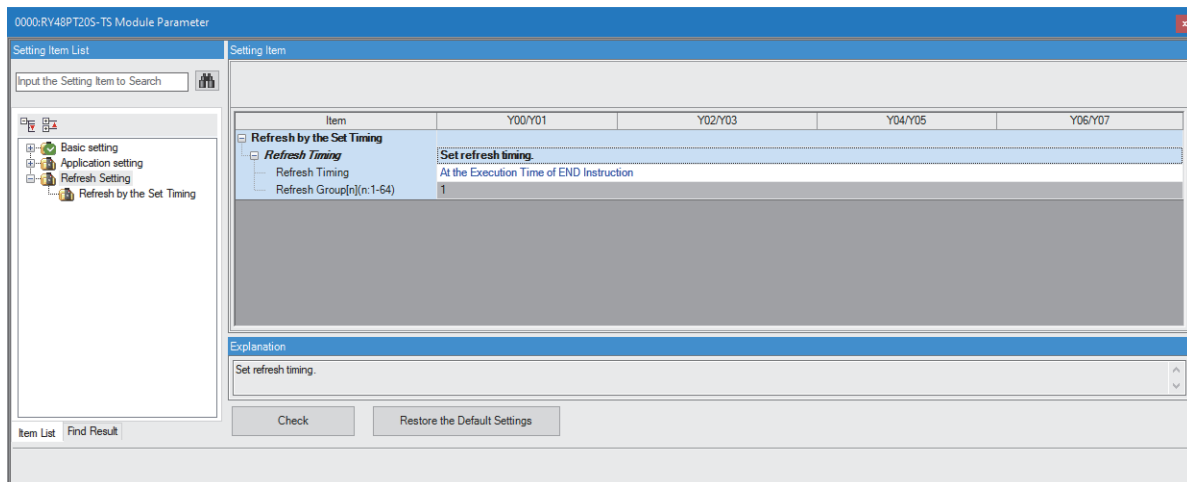

Refresh Timing

Set the refresh timing.

Item	Description	Setting range
Refresh Timing	<p>Set the refresh timing.</p> <ul style="list-style-type: none"> At the Execution Time of END Instruction: Refresh takes place at the time of the END processing of the Safety CPU. At the Execution Time of Specified Program: Refresh takes place at the time of the execution of the program with the group number specified in "Refresh Group Setting" of "CPU Parameter". For details on the setting, refer to the following. <p> MELSEC iQ-R CPU Module User's Manual (Application)</p>	<ul style="list-style-type: none"> At the Execution Time of END Instruction At the Execution Time of Specified Program (Default: At the Execution Time of END Instruction)
Refresh Group[n](n: 1-64)	<p>Set the group number of the program to be refreshed when "Refresh Timing" is set to "At the Execution Time of Specified Program".</p>	<p>1 to 64 (Default: 1)</p>

7

Point

This item is applicable only to I/O signals (X/Y) and is not applicable to safety I/O signals (SA\X, SA\Y). For details on the safety I/O refresh timing, refer to the following.
 MELSEC iQ-R CPU Module User's Manual (Application)

7.3 Safety Module Validation

This function enables the parameters of the safety I/O module.

Perform a safety module validation to start safety control of the safety I/O module.

Procedure for enabling the safety module

The following describes the procedure for enabling the safety module.

1. Displaying the Safety Module Operation window

Display the Safety Module Operation window.

2. Checking the safety module position

Check the safety module position.

3. Safety module validation

Perform safety module validation.

4. Reset the Safety CPU or turn off and on the power.

Displaying the Safety Module Operation window

Display the "Safety Module Operation" window of the engineering tool.

Point

- The "Safety Module Operation" window can be displayed only when the control CPU of the project is a Safety CPU. The window cannot be displayed when the control CPU is other than the Safety CPU.
- When the window starts up or when the [Update] button is clicked, indications of "Module Status" and "Safety Module Position Check Execution Status" of the safety I/O module are updated to the latest status.

Operating procedure

[Online] ⇒ [Safety PLC Operation] ⇒ [Safety Module Operation]

Window

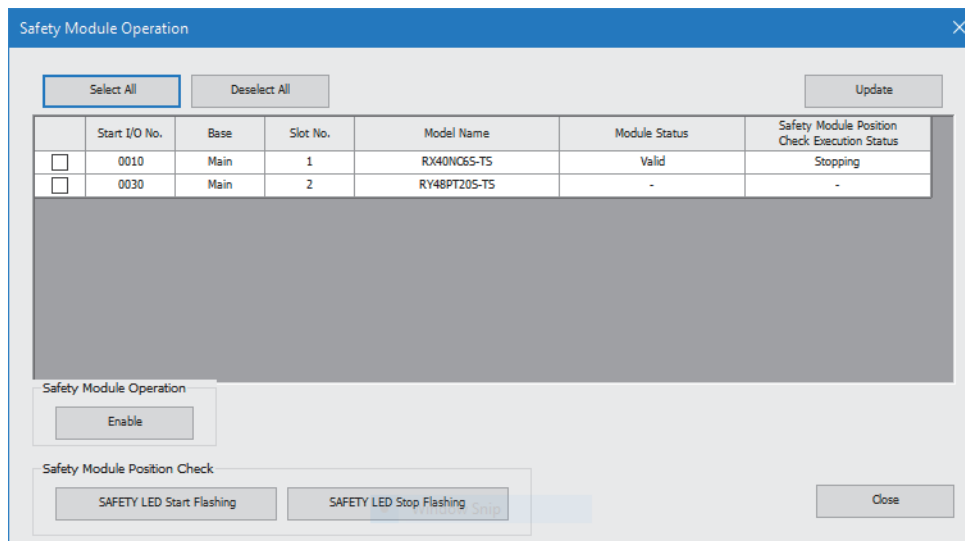

Displayed items

Item	Description
Start I/O Number	Indicates the start I/O number where the safety I/O module is mounted.
Base	Indicates the type of the base on which the safety I/O module is mounted. "Main" or "Extension" is displayed.
Slot Number	Indicates the slot number to which the safety I/O module is mounted.
Model	Indicates the model name of the safety I/O module.
Module Status	Indicates whether the current safety I/O module has been enabled. ☞ Page 49 Module status items displayed
Safety Module Position Check Execution Status	Indicates the safety module position check execution status for the current safety I/O module. ☞ Page 49 Items displayed for the safety module position check execution status

■ Module status items displayed

Display	Description
—	The information is not acquired.
Valid	The safety module is enabled and the configured parameters are valid.
Invalid	The safety module is not enabled and the configured parameters are not valid.
Valid (Reset Wait)	The safety module has just been enabled. The Safety CPU must be reset or the programmable controller must be turned off and on. The module status will be enabled after the reset. At this time, the SAFETY LED flashes every 2 seconds.
Verification Failed	The module parameters are different between the safety I/O module and the safety I/O module in the project in the engineering tool. ☞ Page 88 When "Verification Failed" is displayed
Enabling Failed (Module Error)	The safety module failed to be enabled. ☞ Page 88 When "Enabling Failed (Module Error)" is displayed
Timeout	A timeout occurred because no response was returned from the target module. ☞ Page 88 When "Timeout" is displayed
Processing Failed	Operation failed on the target module. ☞ Page 88 When "Processing Failed" is displayed

■ Items displayed for the safety module position check execution status

Display	Description
—	The information is not acquired.
Stopping	The safety module position check is not executed.
Executing	The safety module position check is in process.
Timeout	A timeout occurred because no response was returned from the target module. ☞ Page 88 When "Timeout" is displayed
Processing Failed	Operation failed on the target module. ☞ Page 88 When "Processing Failed" is displayed

Checking the safety module position

Visually check that the target safety I/O module is mounted at the correct position.

The SAFETY LED of the target safety I/O module can be made to flash at high speed (400ms cycle) by performing the SAFETY LED flashing start operation. By using this function, users can visually check that the module is mounted at the correct position.

Operating procedure

1. Display the "Safety Module Operation" window.

 [Online] ⇒ [Safety PLC Operation] ⇒ [Safety Module Operation]

2. While the target module is selected, click the [SAFETY LED Start Flashing] button.

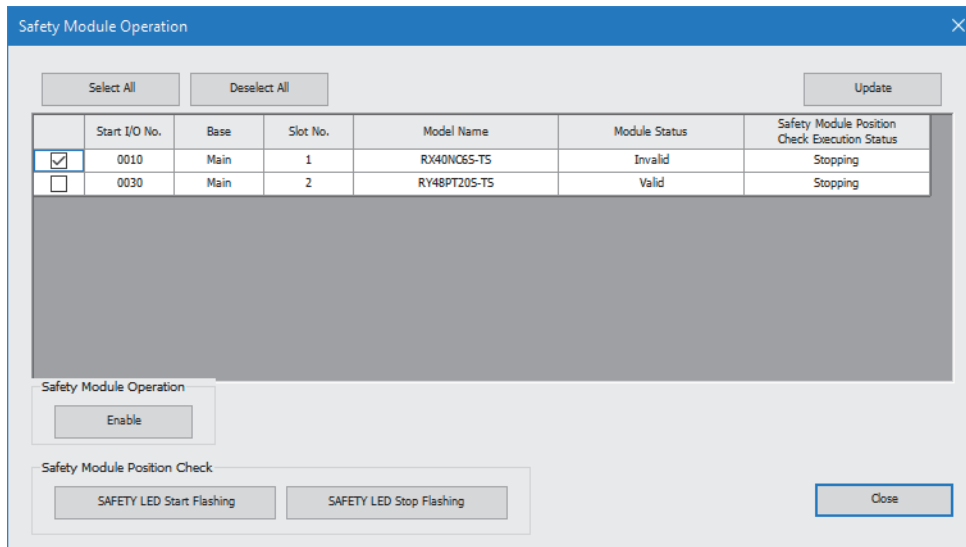

3. Click the [Yes] button.

4. Click the [OK] button.

5. The SAFETY LED of the target module flashes at high speed (400ms cycles), and "Safety Module Position Check Execution Status" becomes "Executing".

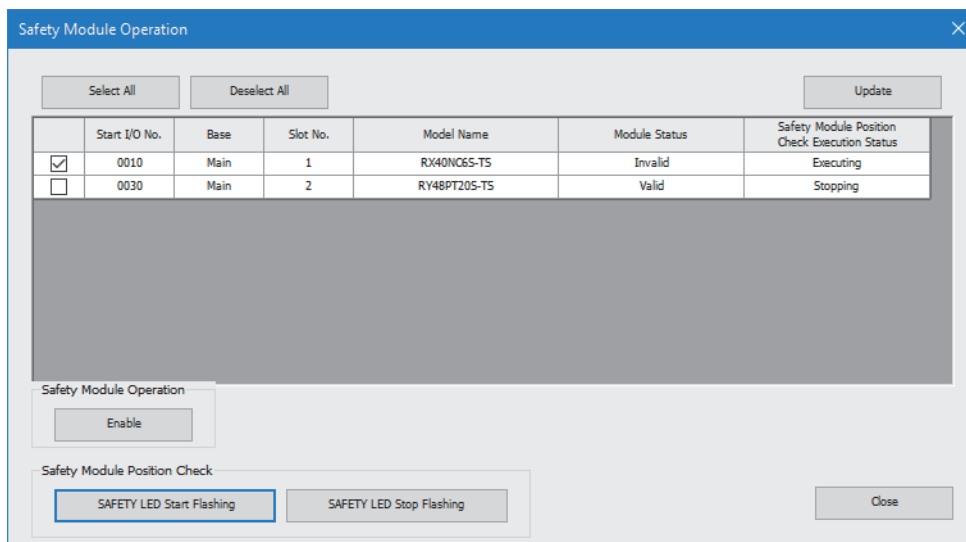

6. To stop the flashing of the SAFETY LED after a safety module position check is complete, click the [SAFETY LED Stop Flashing] button.

7. Click the [Yes] button.

8. Click the [OK] button.

9. The SAFETY LED returns to its original state from flashing at high speed (400ms cycles), and "Safety Module Position Check Execution Status" becomes "Stopping".

	Start I/O No.	Base	Slot No.	Model Name	Module Status	Safety Module Position Check Execution Status
<input checked="" type="checkbox"/>	0010	Main	1	RX40NC65-TS	Invalid	Stopping
<input type="checkbox"/>	0030	Main	2	RY48PT205-TS	Valid	Stopping

Safety module validation

Visually check parameters of the safety I/O module targeted for the safety module validation, and confirm that the parameters are set as intended. After that, follow the procedure below.

Operating procedure

1. While the target module is selected, click the [Enable] button.

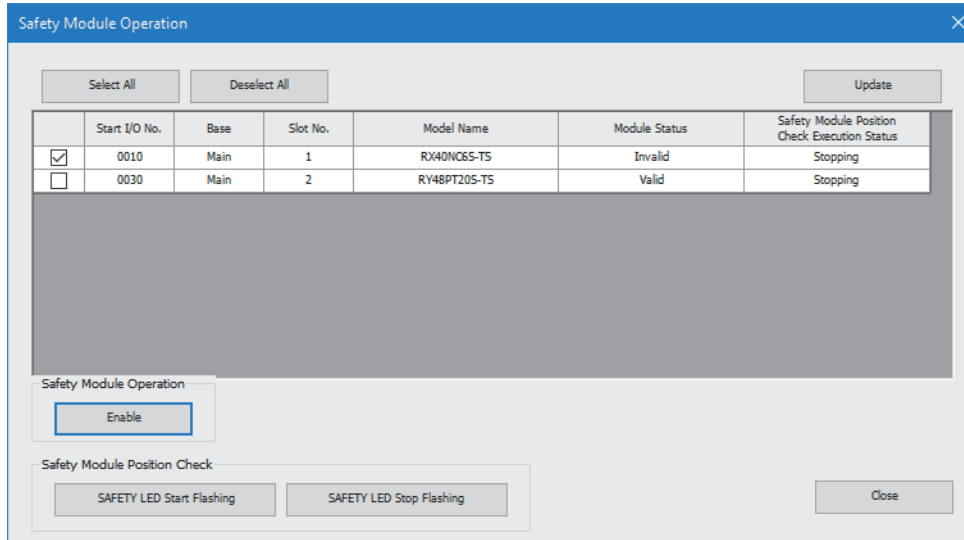

2. Click the [Yes] button.
3. Click the [OK] button. This displays the operation result for "Module Status".
4. Check that "Valid (Reset Wait)" is displayed for "Module Status" and that the SAFETY LED of the safety I/O module is flashing (2s cycles).

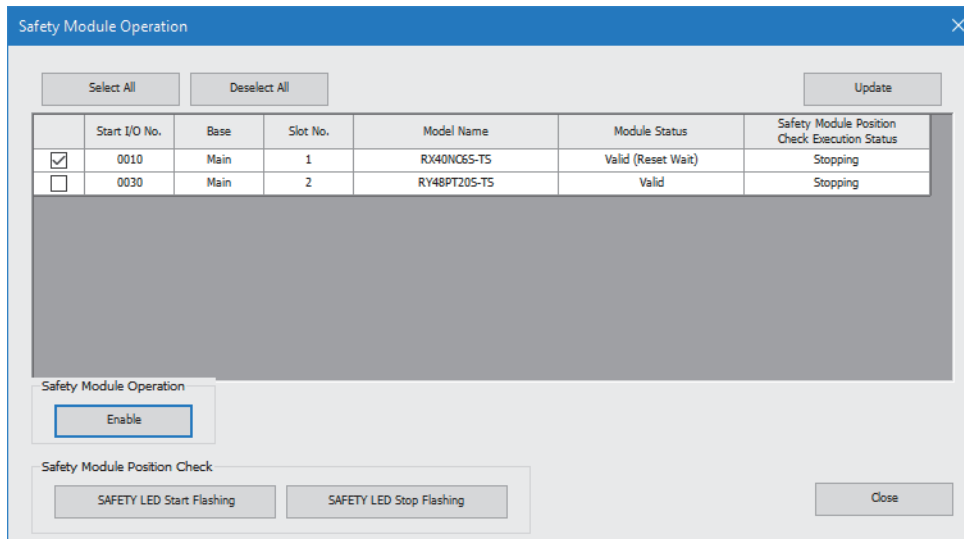

5. Reset the Safety CPU or turn off and on the power.
6. Click the [Update] button.
7. Click the [Yes] button.

8. Check that "Valid" is displayed for "Module Status".

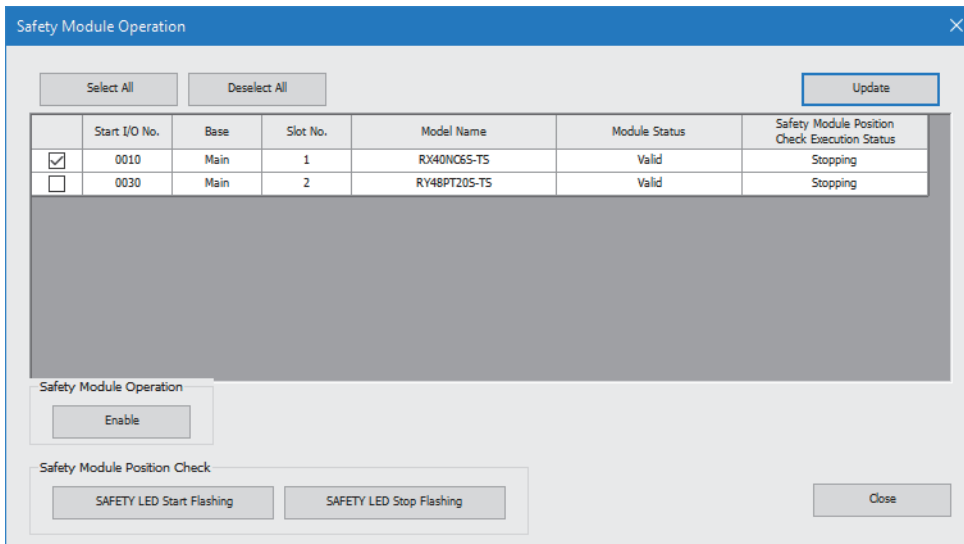

Point

- Ensure that the safety operation mode of the Safety CPU is set to TEST MODE before performing safety module operation. (📖 MELSEC iQ-R CPU Module User's Manual (Application))
- If a safety I/O module where the safety module validation has been completed is attempted to be enabled, the module status does not change.
- Changing a module parameter of a safety I/O module causes Safety module validation status to be Invalid. In this case, the safety module validation must be performed again. However, changing the safety I/O refresh device setting, safety output refresh interval monitoring time, or safety I/O refresh timeout time does not change Safety module validation status.
- To check whether safety module validation has been completed, check the module status in the "Safety Module Operation" window or 'Safety module validation status' (Un\G257). (👉 Page 109 Safety module validation status)

8 FUNCTIONS

8.1 Safety I/O Refresh Function

Safety I/O refresh

The safety I/O refresh function periodically communicates I/O data between the safety I/O module and the Safety CPU by using safety protocols when the operation mode of the safety I/O module is set to safety operation mode. (Page 26 Operation mode and state transition)

For data communications, the safety devices of the Safety CPU are used.

The safety I/O refresh status of the safety I/O module can be checked on the safety special register 'Safety I/O refresh status' (SA\SD1376 to SA\SD1379) of the Safety CPU and the SAFETY LED status.

Operation

Data is automatically transferred between the safety I/O signals of the safety I/O module and the safety devices (SAIX, SAIY, SAIM, SAIB, SAID, SAIW) of the Safety CPU specified in "Safety I/O refresh device setting" in "Basic setting".

The safety device status is reflected from the Safety CPU to the safety output of the safety I/O module.

Also, the safety input status is stored from the safety I/O module to the safety devices of the Safety CPU.

The following figure shows the flow of safety I/O refresh on the Safety CPU and the safety I/O module.

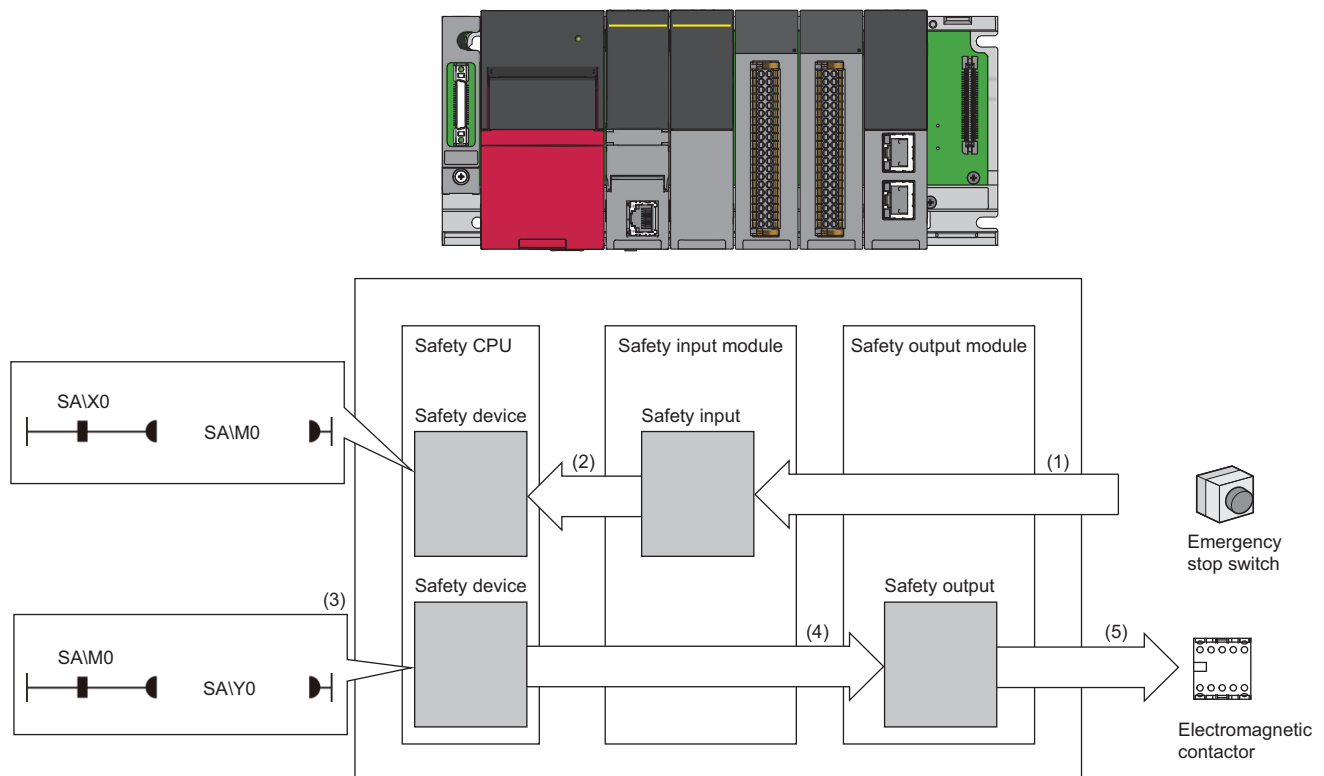

- (1) When data is input from the safety input module, the status of the external device is stored in the safety input of the safety input module.
- (2) Due to safety data transfer, the safety input status is stored from the safety input module to the safety devices of the Safety CPU.
- (3) When data is output from the Safety CPU, the safety device of the Safety CPU turns on.
- (4) Due to safety data transfer, the safety device status is stored from the Safety CPU to the safety output of the safety output module.
- (5) The safety output status of the safety output module is output to the external device.

Point

For details on the safety I/O refresh timing, refer to the following manual.

MELSEC iQ-R CPU Module User's Manual (Application)

Monitoring time for safety I/O refresh

This value indicates the monitoring time for monitoring errors that involve safety I/O refresh.

When a time exceeds the monitoring time, a safety I/O refresh error (error code: 1A03H to 1A09H) is detected, and the safety I/O refresh is stopped.

Item	Description	Module that uses the set time
Safety output refresh interval monitoring time	The safety I/O module monitors the interval at which the Safety CPU sends safety data ((a) in the figure below).	Safety I/O module
Safety I/O refresh timeout time ^{*1}	The Safety CPU monitors the interval at which safety data is received from the safety I/O module ((b) in the figure below).	Safety CPU
	The safety I/O module monitors the interval at which safety data is received from the Safety CPU ((c) in the figure below).	Safety I/O module
Safety input refresh interval monitoring time	The Safety CPU monitors the interval at which the safety I/O module sends safety data ((d) in the figure below).	Safety CPU

*1 For the safety I/O refresh timeout time, a common value is used both for the Safety CPU and the safety I/O module.

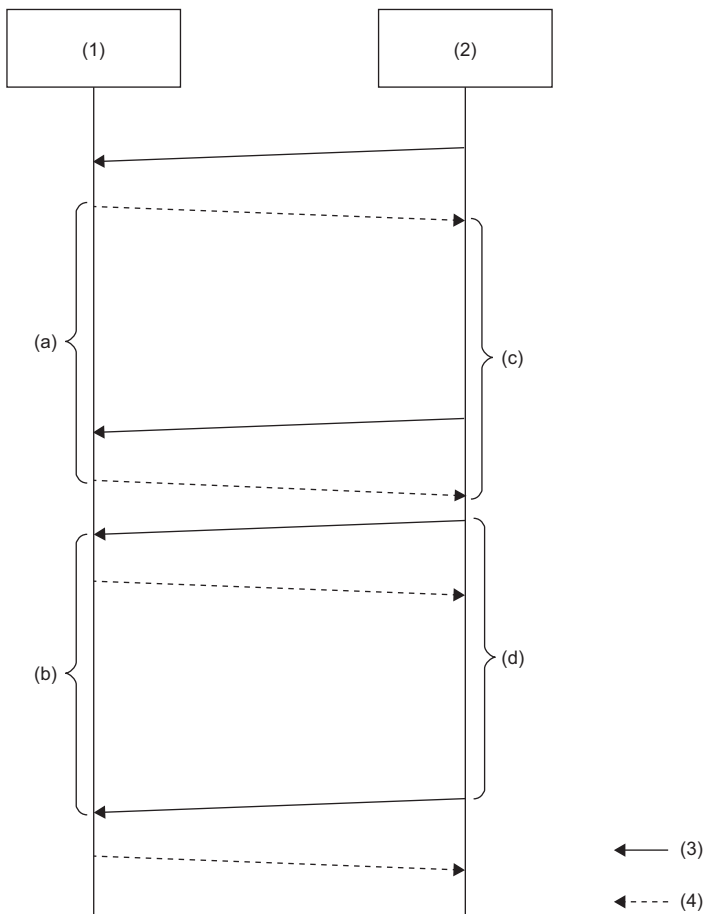

- (1) Safety CPU
- (2) Safety I/O module
- (3) Safety data sent from the safety I/O module to the Safety CPU
- (4) Safety data sent from the Safety CPU to the safety I/O module

■ Safety input refresh interval monitoring time

For the safety input refresh interval monitoring time, set a value that satisfies the following condition.

Calculation formula

$$SIref \geq SCcpu \times 2$$

- SIref: Safety input refresh interval monitoring time
- SCcpu: Safety cycle time of the Safety CPU (set using the CPU parameter of the Safety CPU)

Point

- When the Safety CPU detects safety I/O refresh timeout, check that the value for the safety input refresh interval monitoring time satisfies the calculation formula above.
- When the module is affected by noise, a safety I/O refresh timeout may be detected by the Safety CPU. If safety I/O refresh timeout is detected repeatedly, add an integral multiple of the safety cycle time of the Safety CPU to the safety input refresh interval monitoring time.
- When the safety input refresh interval monitoring time has been changed, change the safety I/O refresh timeout time as well so that the conditions described for the safety I/O refresh timeout time are met.

■ Safety output refresh interval monitoring time

For the safety output refresh interval monitoring time, set a value that satisfies the following condition.

Calculation formula

$$SOref \geq SCcpu \times 3$$

- SOref: Safety output refresh interval monitoring time
- SCcpu: Safety cycle time of the Safety CPU (set using the CPU parameter of the Safety CPU)

Point

- If a safety I/O refresh error (error code: 1A03H to 1A09H) is detected, check that the value for the safety output refresh interval monitoring time satisfies the calculation formula above.
- When the module is affected by noise, a safety I/O refresh error (error code: 1A03H to 1A09H) may be detected. If the safety I/O refresh error is detected repeatedly, add an integral multiple of the safety cycle time of the Safety CPU to the safety output refresh interval monitoring time.
- When the safety output refresh interval monitoring time has been changed, change the safety I/O refresh timeout time as well so that the conditions described for the safety I/O refresh timeout time are met.

■ Safety I/O refresh timeout time

For the safety I/O refresh timeout time, set a value that satisfies all of the following conditions.

Calculation formula

$$RT \geq SOref + SCio$$

$$RT \geq SIref + SCcpu$$

- RT: Safety I/O refresh timeout time
- SOref: Safety output refresh interval monitoring time (set using the module parameter of the safety I/O module)
- SIref: Safety input refresh interval monitoring time (set using the module parameter of the safety I/O module)
- SCio: Safety cycle time of the safety I/O module ( Page 17 Performance Specifications)
- SCcpu: Safety cycle time of the Safety CPU (set using the CPU parameter of the Safety CPU)







Point

- If a safety I/O refresh error (error code: 1A03H to 1A09H) is detected, check that the value for the safety I/O refresh timeout time satisfies the calculation formulas above.
- When safety I/O refresh is affected by noise, a safety I/O refresh timeout may be detected by the Safety CPU. If safety I/O refresh timeout is detected repeatedly, compare SOref and SIref, then add an integral multiple of whichever time is larger to the safety I/O refresh timeout time.

Setting method

Set safety I/O refresh using the module parameters of the safety I/O module.

 [Navigation window] ⇨ [Parameter] ⇨ [Module Information] ⇨ Module model name ⇨ [Module Parameter]

Item	Description	Reference
Safety I/O refresh device setting	Set the safety device used for safety I/O refresh.	 Page 40 Safety I/O refresh device setting  Page 45 Safety I/O refresh device setting
Safety input refresh interval monitoring time	Set the safety input refresh interval monitoring time to detect safety I/O refresh errors. Set a value that satisfies the calculation formula for the monitoring time.  Page 56 Safety input refresh interval monitoring time	 Page 40 Safety I/O refresh monitoring time  Page 45 Safety I/O refresh monitoring time
Safety output refresh interval monitoring time	Set the safety output refresh interval monitoring time to detect safety I/O refresh errors. Set a value that satisfies the calculation formula for the monitoring time.  Page 56 Safety output refresh interval monitoring time	
Safety I/O refresh timeout time	Set the safety I/O refresh timeout time to detect safety I/O refresh errors. Set a value that satisfies the calculation formula for the timeout time.  Page 56 Safety I/O refresh timeout time	

■Precautions

Do not set overlapping safety devices for use with the following.

- "Safety I/O refresh device setting" of the safety I/O module for which the same control CPU is set.
- "Safety Data Transfer Device Setting" of "Safety Communication Setting" of master/local modules of CC-Link IE Field Network and CC-Link IE TSN

Safety I/O refresh interlock

When a safety I/O refresh error occurs, safety data transfer is automatically stopped to prevent incorrect input and incorrect output.

This function prevents machines that have stopped due to a safety I/O refresh error from suddenly restarting due to recovery from the safety I/O refresh error.

Operation

When a major error, moderate error, or safety I/O refresh error (error code: 1A03H to 1A09H) occurs on the safety I/O module, the Safety CPU enters the safety I/O refresh interlock state and safety I/O refresh stops.

Checking method

Check in the safety special register of the Safety CPU 'Safety I/O refresh interlock state' (SA\SD1392 to SA\SD1395).

For details, refer to the following manual.

 MELSEC iQ-R CPU Module User's Manual (Application)

Release method

Release the interlock with the safety special register of the Safety CPU 'Interlock release request for safety I/O refresh' (SA\SD1400 to SA\SD1403).

For details, refer to the following manual.

 MELSEC iQ-R CPU Module User's Manual (Application)

For whether safety I/O refresh has restarted, check the safety special register 'Safety I/O refresh status' (SA\SD1376 to SA\SD1379) of the Safety CPU.

8.2 Safety Input Function

This function safely inputs external signals. This function cannot be used in any modes other than the safety operation mode. All the safety inputs (SAIX) are off in any modes other than the safety operation mode. In the safety operation mode, 24VDC output of the test pulse output terminals (T0 to T3) is enabled.

Input wiring selection function

This function is used to select double wiring or single wiring of the input wiring.

Double wiring function

The double wiring function supports double input wiring.

By verifying input signals of double wiring, safety inputs can be turned off even though one of the signals has an error.

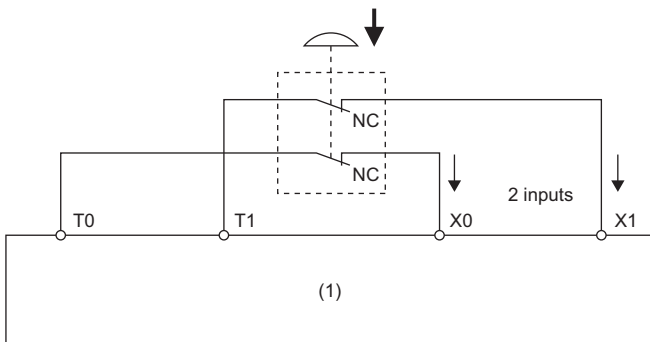

(1) Safety input module

Combination for double wiring

Use the following combinations of input terminals for double wiring to the safety input module.

Combination of input terminals							
X0, X1	X2, X3	X4, X5	X6, X7	X8, X9	XA, XB	XC, XD	XE, XF

Single wiring function

This function can connect input devices with single wiring.

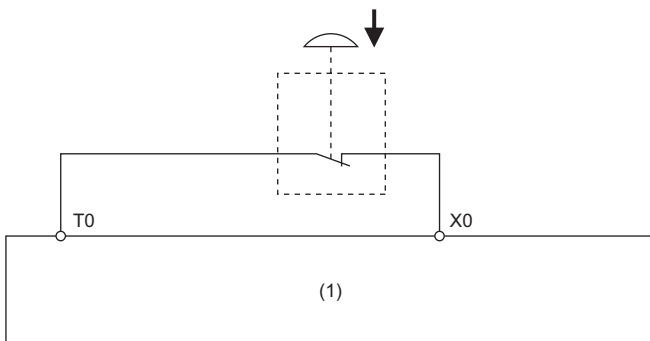

(1) Safety input module

Point

- To satisfy SIL3 and Category 4 PLe, use the double wiring function.
- Although the single wiring function can be used for input using safety devices, systems that use single wiring do not satisfy SIL3 or Category 4 PLe.

Diagnostic functions to detect input errors

Input errors can be detected by using the following diagnostic functions.

Diagnostic function	Description	Reference
Double input discrepancy detection function	Detects the discrepancy of double input signals.	☞ Page 65 Double input discrepancy detection function
Input dark test function	Outputs test pulses to turn off the inputs that are on and diagnoses contacts including external devices for failure.	☞ Page 68 Input dark test function

Combination of double inputs

The safety input module evaluates the logic of input signals and reflects the results to safety inputs (SA\X) assigned by the CPU. When the double input signals differ, the double input discrepancy detection state is applied. The following table lists the correspondence between each double input signal state and safety input (SA\X).

Input terminal state		Safety input		Evaluation result of double inputs
Xn^{*1}	$Xn+1^{*1}$	$SA\Xm^{*2}$	$SA\Xm+1^{*2}$	
OFF	OFF	OFF	OFF	OFF (Normal)
OFF	ON	OFF	OFF	OFF (Discrepancy)
ON	OFF	OFF	OFF	OFF (Discrepancy)
ON	ON	ON	ON	ON (Normal)

*1 n is an even number from 0 to E.

*2 m is the safety device address (even number from 0 to E) assigned in the safety I/O refresh device settings.

States of safety inputs (SA\X0, SA\X1) for X0 and X1 (double wiring)

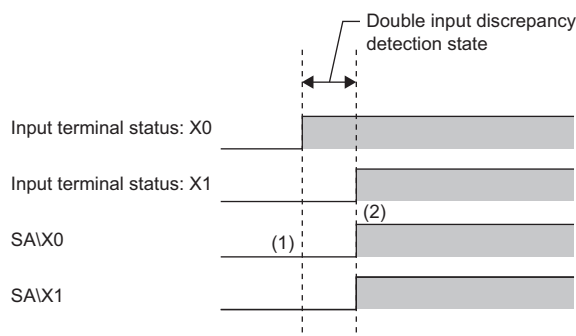

(1) Even when the input terminal X0 turns on, SA\X0 does not turn on because X1 is off.

(2) When the double inputs are on (X0 and X1 are on), SA\X0 and SA\X1 turn on.

External input signal monitor function

The state of input terminals can be monitored. This function facilitates the investigation for the cause of a double input discrepancy error. For details, refer to the following.

☞ Page 99 External input monitor signal

Point

- External input monitor signal is used to investigate the cause of a double input discrepancy error, and thus do not use this signal in a safety program.
- The external input signal monitor function is enabled as well for input terminals where "Wiring selection of input" is set to "Not used".

Setting method

 [Navigation window] ⇒ [Parameter] ⇒ [Module Information] ⇒ Module model name ⇒ [Basic setting] ⇒ [Safety input function]

Item	Description	Reference
Wiring selection of input*1*2	Set the input wiring in units of 2 input points.	 Page 39 Safety input function

*1 For unused input terminals, set "Not used" in "Wiring selection of input".

*2 For input terminals where "Wiring selection of input" is set to "Not used", safety input signals are always off.

Input response time setting function

The input response time setting function is used to set the filter time to reduce incorrect inputs caused by noise in input signals.

The longer the input response time is, the higher tolerance for chattering and noise the module has. But the response to input signals becomes slower. The shorter the input response time is, the quicker the response to input signals is. But the tolerance for chattering and noise is reduced. To set the input response time, consider fully the operating environment.

Point 

When connecting the safety input module to an external device where OFF pulses are generated, set a time equal to or longer than the time of "the minimum value of the input response time + OFF pulse time of the external device" as the input response time. If the input response time is set with the OFF pulse time of the external device not added, an OFF pulse of the external device may be detected as an OFF signal.

Ex.

When Input response time is set to "1ms"

Without any noise effects, the time set in input response time and the time taken from when an external input turns on or off until when the corresponding X input signal in the safety input module turns on or off are equal.

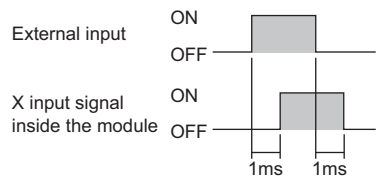

Relation of the parameters for the input response time and input dark test

Set the input response time that satisfies the following condition for an input terminal whose "Input dark test execution setting" is set to "Perform".

Conditional formula

- Input response time > Input dark test pulse output time*1

*1 Input dark test pulse output time = Pulse OFF time for the input dark test × ((Number of pulse outputs for the input dark test × 2) - 1)
 If the condition is not satisfied, a parameter data error (input response time) (error code: 3264H) is detected. For details on the input dark test, refer to the following.

 Page 68 Input dark test function

Setting method

 [Navigation window] ⇒ [Parameter] ⇒ [Module Information] ⇒ Module model name ⇒ [Basic setting] ⇒ [Input response time setting function]

Item	Description	Reference
Input response time*1	To prevent malfunction of the input signal, set the sensitivity to react to the input signal in units of 2 input points.	 Page 39 Input response time setting function

*1 For input terminals where "Wiring selection of input" is set to "Not used", this parameter is ignored.

8.3 Safety Output Function

This function safely outputs signals. This function cannot be used in any modes other than the safety operation mode. All the safety outputs (SA\Y) are off in any modes other than the safety operation mode.

Output wiring selection function

This function is used to select double wiring or single wiring of the output wiring.

Double wiring function

The double wiring function supports double outputs. By multiplying output signals using double wiring, safety outputs can be turned off even though one of the signals has an error.

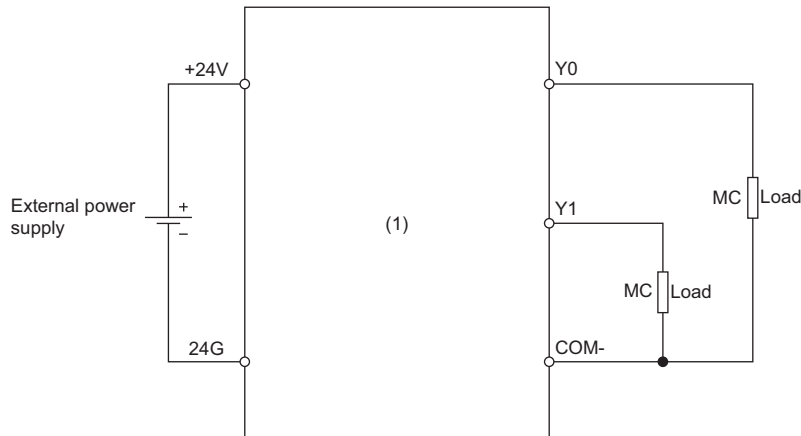

(1) Safety output module

■Combination for double wiring

Use the following combinations of output terminals for double wiring to the safety output module.

Combination of output terminals			
Y0, Y1	Y2, Y3	Y4, Y5	Y6, Y7

Single wiring function

This function can connect output devices with single wiring.

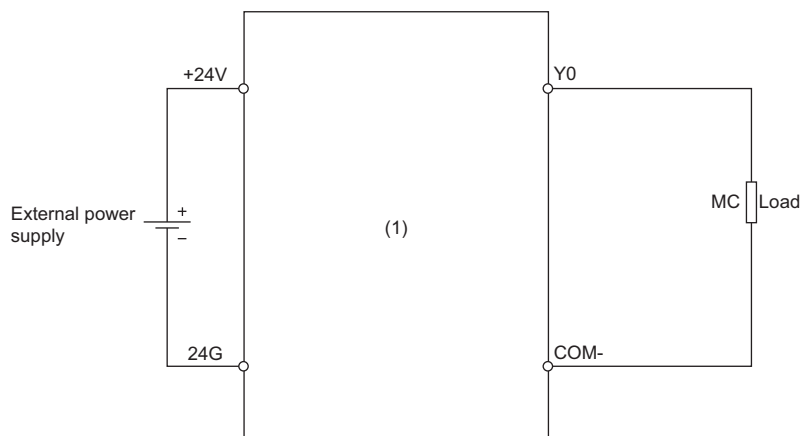

(1) Safety output module

Point

- To satisfy SIL3 and Category 4 PLe, use the double wiring function.
- Although the single wiring function can be used for output using safety devices, systems that use single wiring do not satisfy SIL3 or Category 4 PLe.

Diagnostic functions to detect output errors

Output errors can be detected by using the following diagnostic functions.

Diagnostic function	Description	Reference
Output dark test function	Outputs test pulses to turn off the outputs that are on and diagnoses contacts for failure.	Page 71 Output dark test function
Output read-back function	Reads back output results and diagnoses whether the outputs are correctly on or off.	Page 72 Output read-back function

Combination of double outputs

Both terminals of double outputs are turned on only when safety outputs (SAIY) are on. The safety output module evaluates the logic of safety outputs (SAIY) and determines the state of the output terminals. The following table lists the correspondence between each state of safety output (SAIY) and output terminal for double outputs.

Safety output		Output terminal state		Evaluation result of double outputs
SAIY ^m *1	SAIY ^{m+1} *1	Y ⁿ *2	Y ⁿ⁺¹ *2	
OFF	OFF	OFF	OFF	OFF (Normal)
OFF	ON	OFF	OFF	OFF (Discrepancy)
ON	OFF	OFF	OFF	OFF (Discrepancy)
ON	ON	ON	ON	ON (Normal)

*1 m is the safety device address (even number from 0 to 6) set in the safety I/O refresh device settings.

*2 n is an even number from 0 to 6.

Point

Even if the double outputs do not match, the safety output module does not detect an error.

States of safety outputs (SAIY0, SAIY1) for Y0 and Y1 (double wiring)

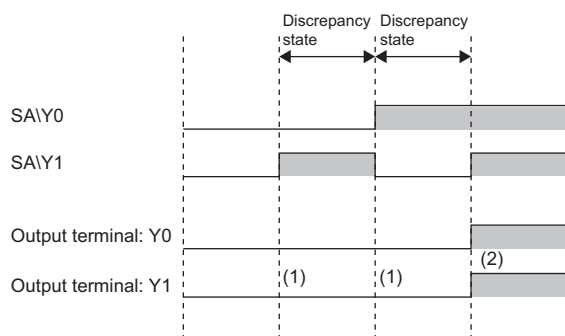

(1) When double outputs (source/source) are in the discrepancy state (SAIY0 and SAIY1 are different), Y0 and Y1 are off.

(2) When double outputs (source/source) are on (SAIY0 and SAIY1 are on), Y0 and Y1 are on.

Setting method

[Navigation window] ⇒ [Parameter] ⇒ [Module Information] ⇒ Module model name ⇒ [Basic setting] ⇒ [Safety output function]

Item	Description	Reference
Wiring selection of output*1*2	Set the output wiring in units of 2 output points of.	Page 44 Safety output function

*1 For unused output terminals, set "Not used" in "Wiring selection of output".

*2 For output terminals where "Wiring selection of output" is set to "Not used", safety output signals are always off.

8.4 Input Diagnostic Function

Double input discrepancy detection function

This function discriminates failures by monitoring the discrepancy state of doubled I/O signals.

Double input discrepancy detection

If "Double input discrepancy detection setting" in "Application setting" is set to "Detect", a double input discrepancy detection error is generated as an input error when the discrepancy state of double inputs continues for the set time or longer.

For the double input discrepancy detection time, refer to the following.

☞ Page 65 Double input discrepancy detection time

The following figure shows the operation overview of double wiring input X0/X1 (NC/NC) connection.

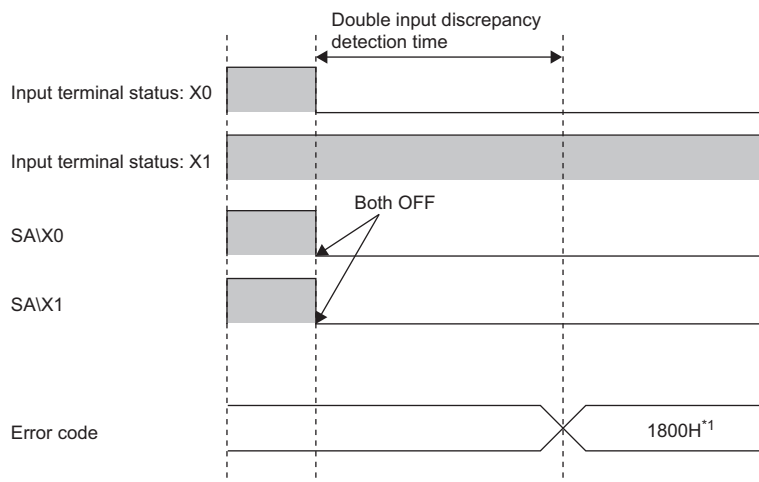

*1 After the double input discrepancy error detection time elapses, a double input discrepancy detection error (error code: 1800H) occurs.

Double input discrepancy detection time

When the double input discrepancy detection time is set, an error does not occur during the set detection time even if double input discrepancy is detected. The following table lists the relation of each double input evaluation result and the double input discrepancy detection time.

Input terminal state		Time that has passed after the double input discrepancy state is applied	Safety input signals		Evaluation result of double inputs
Xn*1	Xn+1*1		SAIXm*2	SAIXm+1*2	
OFF	OFF	—	OFF	OFF	OFF (Normal)
OFF	ON	< Double input discrepancy detection time	OFF	OFF	OFF (Discrepancy)
OFF	ON	≥ Double input discrepancy detection time	OFF	OFF	Double input discrepancy detection error
ON	OFF	< Double input discrepancy detection time	OFF	OFF	OFF (Discrepancy)
ON	OFF	≥ Double input discrepancy detection time	OFF	OFF	Double input discrepancy detection error
ON	ON	—	ON	ON	ON (Normal)

*1 n is an even number from 0 to E.

*2 m is the safety device address (even number from 0 to E) set in the safety I/O refresh device settings.

Double input discrepancy auto recovery function

When a double input discrepancy detection error has occurred, removing the error factor recovers the module into the normal state automatically.

By enabling this function, restarting the safety input module to recover from the error is not required.

■Auto recovery timing

To clear a double input discrepancy detection error, turning off both of the actual input signals is required. The following figure shows the timing of when the module is automatically recovered from a double input discrepancy detection error.

Ex.

"Double input discrepancy auto recovery setting" in "Application setting": "Used"

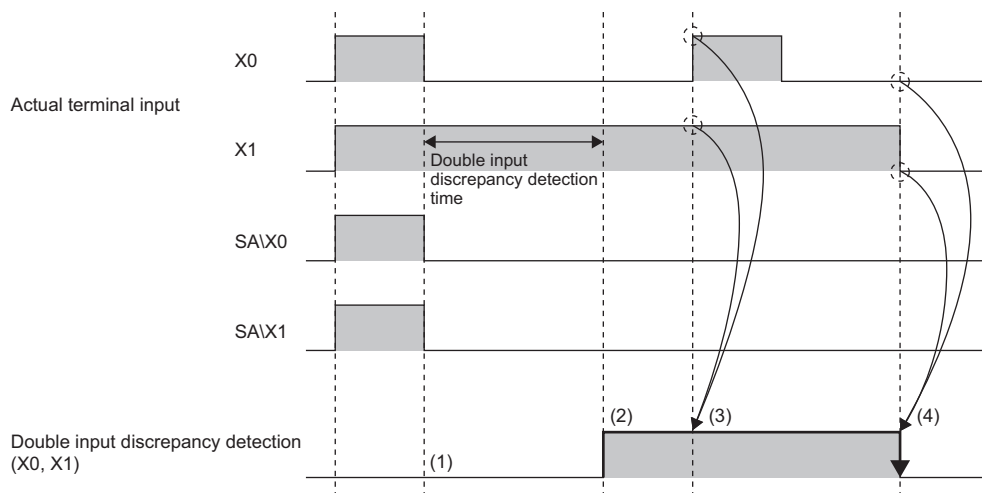

- (1) Both SAIX0 and SAIX1 turn off when discrepancy is detected.
- (2) A double input discrepancy detection error occurs.
- (3) The auto recovery is not performed even though both X0 and X1 turn on.
- (4) The auto recovery is performed when both X0 and X1 turn off.

Checking the double input discrepancy state

The state can be checked with 'Double input discrepancy state X0 X1' (SAIX10) to 'Double input discrepancy state XE XF' (SAIX17). (Page 102 Double input discrepancy state)

Point

Do not use 'Double input discrepancy state X0 X1' (SAIX10) to 'Double input discrepancy state XE XF' (SAIX17) in a safety program.

Operation at error detection

When the discrepancy state of double inputs continues for the set time or longer, the double input discrepancy detection error (error code: 1800H) occurs, and the corresponding input point is turned off.

Also, the generation terminal bit in 'Input state area' (Un\G769) is turned on.

Setting method

The double input discrepancy detection function is set using the following module parameters.

 [Navigation window] ⇒ [Parameter] ⇒ [Module Information] ⇒ Module model name ⇒ [Module Parameter] ⇒ [Application setting]

Item	Description	Reference
Double input discrepancy detection setting ^{*1}	Set whether to detect double input discrepancy in units of 2 input points. When double input discrepancy errors do not need to be detected during equipment maintenance including system start-up and inspection, set "Do not detect".	 Page 41 Double input discrepancy detection function
Double input discrepancy auto recovery setting ^{*3}	Set whether to recover the normal state automatically when a double input discrepancy detection error has occurred and the error factor has been removed.	
Double input discrepancy detection time ^{*1*2}	Set the double input discrepancy allowed time in units of 2 input points.	

*1 When an item other than "Double wiring (NC/NC)" is set in "Wiring selection of input" of "Basic setting", this setting is ignored.

*2 When "Do not detect" is set in "Double input discrepancy detection setting", this setting is ignored.

*3 This setting is enabled only for an input signal where "Detect" is set in "Double input discrepancy detection setting".

Point

- A double input discrepancy error is detected in signals after the input response time has elapsed. Therefore, the time taken from when actual signals are in the discrepancy state until when a double input discrepancy detection error occurs is equal to the input response time + double input discrepancy detection time.
- Set the double input discrepancy detection time based on the following values: 100ms for mechanical switches and 20ms for sensor inputs.

Reference for the double input discrepancy detection time

Status	Set time
When the synchronous time for double inputs can be defined	For the devices, including safety relays and safety switches, whose synchronous time specifications are published in their manuals and other documents, set a value considering the safety factor for false detection. Determine a safety factor of 2 times or higher to prevent false detection depending on the input devices used. For example, when the synchronous time is 1s, 2s shall be set in "Double input discrepancy detection time" considering the safety factor of 2 times.
When the synchronous time for double inputs cannot be defined	When the synchronous time cannot be defined for the application, such as usage of a door switches that are opened or closed manually, set the maximum time or set "Do not detect" in "Double input discrepancy detection setting". Even when "Do not detect" is set, the system stops when one of the input signals turns off. Therefore, safety is ensured by inspecting the safety input module periodically at a sufficiently short interval.

Input dark test function

This function outputs test pulses to turn off the inputs that are on and diagnoses contacts including external devices for failure. Failures including circuit fixing and short-circuit faults can be detected. The OFF time for test pulses and the number of pulse outputs used in one diagnostic can be set depending on the usage environment.

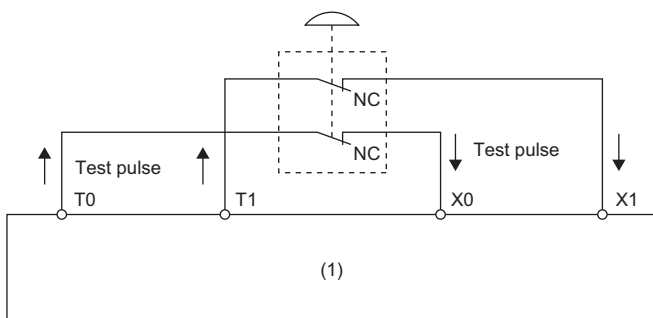

(1) Safety input module

To use the input dark test function, use the test pulse output terminals (T0 to T3) and connect input devices.

To use the input dark test function, use the input terminals and the test pulse output terminals (T0 to T3) of the safety input module in the following combinations. Connection to an incorrect test pulse output terminal is regarded as a disconnection, and an input dark test error (error code: 1801H) is detected.

Test pulse output terminal	Input terminal
T0	X0, X4, X8, XC
T1	X1, X5, X9, XD
T2	X2, X6, XA, XE
T3	X3, X7, XB, XF

Point

The input dark test detects short-circuits between input terminals connected to different test pulse output terminals.

- It cannot detect short-circuits between input terminals connected to the same test pulse output terminal.
- Thus, do not use the input dark test for a system where a short-circuit fault may occur between input terminals connected to the same test pulse output terminal.

Operation at error detection

When an error is detected in a diagnostic of the input dark test, the input dark test error (error code: 1801H) occurs.

Also, the generation terminal bit in 'Input state area' (Un\G769) is turned on.

Point

The error detection using the test pulses is not performed for input terminals where "Wiring selection of input" in "Basic setting" is set to "Not used". (☞ Page 59 Input wiring selection function)

Setting method

Set the input dark test function by using the following module parameters.

 [Navigation window] ⇒ [Parameter] ⇒ [Module Information] ⇒ Module model name ⇒ [Module Parameter] ⇒ [Application setting]

Item	Description	Reference
Input dark test execution setting ^{*1}	Set whether to perform the input dark test function in units of 2 input points.	 Page 42 Input dark test function
Input dark test pulse OFF time setting ^{*1*2}	Set the width of the OFF pulses that the terminals T0 to T3 output. Adjust the set value according to the installation environment or wiring length.	
Number of pulse output for input dark test ^{*1*2}	Set the number of OFF pulses for input dark test diagnostics. Adjust the set value according to the installation environment or wiring length.	

*1 This setting is ignored and the error detection using the test pulses is not performed for input terminals where "Wiring selection of input" in "Basic setting" is set to "Not used".

*2 This setting is ignored for input terminals where "Input dark test execution setting" is set to "Do not perform".

Point

There is a mutual relation of the parameter values of the input response time and input dark test. For details, refer to the following.

 Page 62 Input response time setting function

Internal input dark test function

This function outputs test pulses to the internal input circuit of the safety input module to detect a circuit-fixing failure. The test pulses turn off the inputs that are on to detect the failure.

The function is conducted to safety input signals where "Wiring selection of input" in "Basic setting" is set to an item other than "Not used".

The parameter setting is not required to use the internal input dark test function.

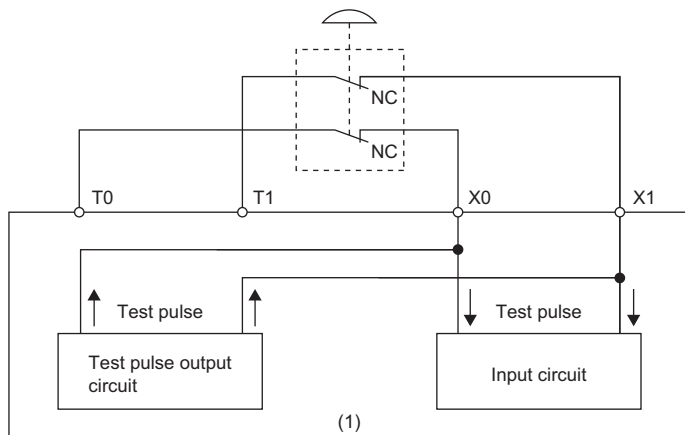

(1) Safety input module

Operation at error detection

When an error is detected in a diagnostic of the internal input dark test, the input internal dark test error (error code: 3500H) occurs.

Also, the generation terminal bit in 'Input state area' (Un\G769) is turned on.

8.5 Output Diagnostic Function

The output diagnostic function is a safety function for determining failure of output signals using the safety output function.

Output dark test function

This function outputs test pulses to turn off outputs that are on and diagnoses the internal circuit for failure.

The read-back circuit checks the test pulse and output circuit fixing can be detected.

The OFF time for test pulses and the number of pulse outputs used in one diagnostic can be set depending on the usage environment.

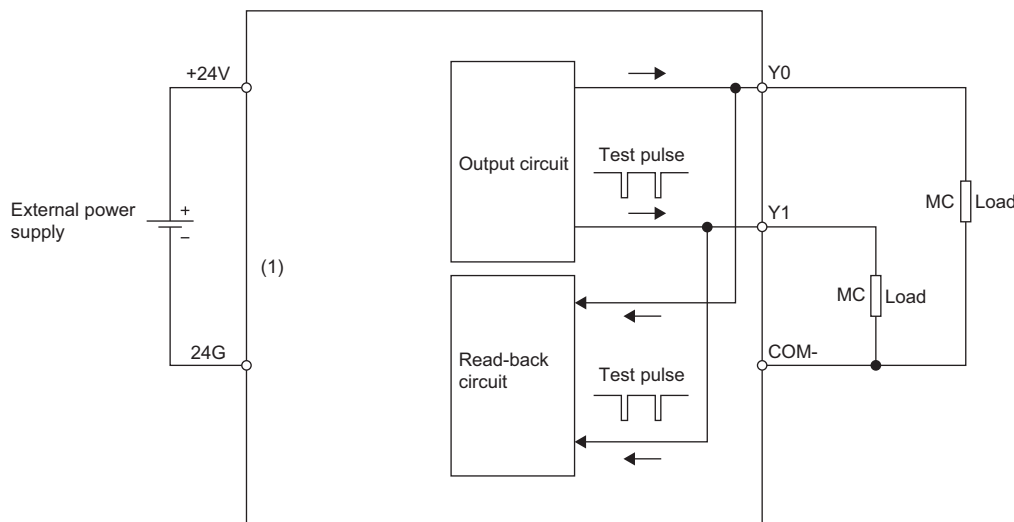

(1) Safety output module

Operation at error detection

When an error is detected in a diagnostic of the output dark test, the output dark test error (error code: 3401H) occurs and all output points are turned off.

Also, the generation terminal bit in 'Output state area' (Un\G1280) is turned on.

Point

Test pulses are not output when "Wiring selection of output" in "Basic setting" is set to "Not used". (Page 44 Safety output function)

Setting method

Set the output dark test function by using the following module parameters.

[Navigation window] ⇒ [Parameter] ⇒ [Module Information] ⇒ Module model name ⇒ [Module Parameter] ⇒ [Application setting]

Item	Description	Reference
Output dark test execution setting ^{*1}	Set whether to perform the output dark test function in units of 2 output points.	Page 46 Output dark test function
Output dark test pulse OFF time setting ^{*1*2}	Set the width of OFF pulses used for an output dark test in units of 2 output points. Adjust the set value according to the installation environment or wiring length.	
Number of pulse output for output dark test ^{*1*2}	Set the number of OFF pulses for output dark test diagnostics in units of 2 output points. Adjust the set value according to the installation environment or wiring length.	

*1 This setting is ignored and the test pulses are not output for output terminals where "Wiring selection of output" in "Basic setting" is set to "Not used".

*2 This setting is ignored for output terminals where "Output dark test execution setting" is set to "Do not perform".

Output read-back function

This function reads back output results and diagnoses whether the output signal is correctly on or off.

By diagnosing whether the output terminal status matches the output data of the safety device, the output read-back function detects output operation errors of the module.

The parameter setting is not required to use the output read-back function.

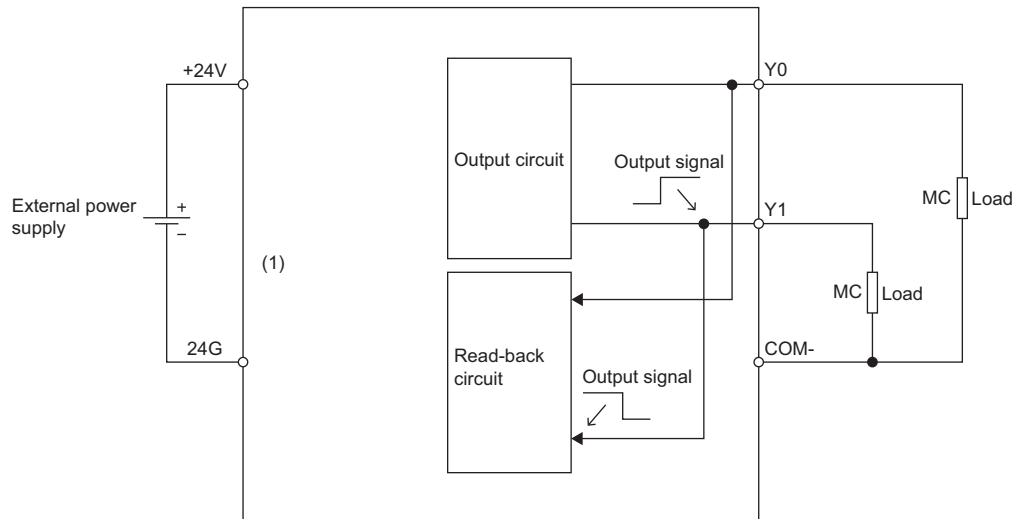

(1) Safety output module

Operation at error detection

When an error is detected by the output read-back diagnostic, the output read-back error (error code: 3400H) occurs and all output points are turned off.

Also, the generation terminal bit in 'Output state area' (Un\G1280) is turned on.

8.6 Protection Functions

The following table lists the protection functions.

Function name	Purpose	Description
Module power supply overvoltage protection	Prevents ignition or burnouts from/of the safety I/O module due to overvoltage on the primary side.	This function operates when the internal power supply of the module is in the primary side overvoltage state.
Module power supply overcurrent protection	Prevents ignition or burnouts from/of the safety I/O module due to overcurrent on the primary side.	This function operates when the internal power supply of the module is in the primary side overcurrent state.
External power supply overvoltage protection	Prevents ignition or burnouts from/of the safety I/O module and load circuits due to overvoltage.	This function operates when the external power supply circuit is in the primary side overvoltage state.



The protection functions are intended to protect the internal circuit of a module, not to protect external devices.

8.7 Operation Setting Function at Detection of External Power Supply Voltage Error

Users can select whether to continue safety I/O refresh or stop it when an external power supply voltage error occurs.

Restoration

The following table shows how the module operation will be restored from the external power supply voltage error.

Item	Restoration	Operation at the error	Error status of the module	Reference
Stop safety I/O refresh	After causes of the external power supply voltage error are eliminated, the safety inputs and safety outputs will restart by resetting the Safety CPU or turning off and on the power to the programmable controller.	<ul style="list-style-type: none"> Safety I/O refresh is stopped. Safety inputs and safety outputs are OFF. External power supply is turned off. 	Moderate error (External power supply voltage error (error code: 3600H))	☞ Page 74 Stop safety I/O refresh
Continue safety I/O refresh (Without output interlock)*1	Safety I/O refresh continues, but safety outputs are turned off. After the error causes are eliminated, a minor error in the module will be cleared and the safety outputs will restart. The control will restart at the canceling of the safety output interlock by the external circuit.	<ul style="list-style-type: none"> Safety I/O refresh is continued. Safety inputs and safety outputs are OFF. (interlock by the external circuit) 	Minor error (External power supply voltage error (error code: 1A00H))	☞ Page 75 Continue safety I/O refresh (Without output interlock)
Continue safety I/O refresh (With output interlock)	Safety I/O refresh continues, but safety outputs are turned off and the outputs are interlocked. After the error causes are eliminated, at the canceling of the interlock by the Safety CPU, the safety outputs will restart.	<ul style="list-style-type: none"> Safety I/O refresh is continued. Safety inputs and safety outputs are OFF. (interlock by the module) 	Minor error (External power supply voltage error (error code: 1A00H))	☞ Page 77 Continue safety I/O refresh (With output interlock)

*1 To prevent unintended restart, configure an external interlock circuit for the safety outputs.

Point

- The interlock is applied to outputs from the Yn terminal and the test pulse output terminals (T0 to T3).
- If a moderate external power supply voltage error occurs, the outputs from the Yn terminal and the test pulse output terminals (T0 to T3) are forcibly turned off.

Stop safety I/O refresh

■ Output interlock

After an external power supply voltage error is detected, safety I/O refresh stops and the outputs are interlocked.

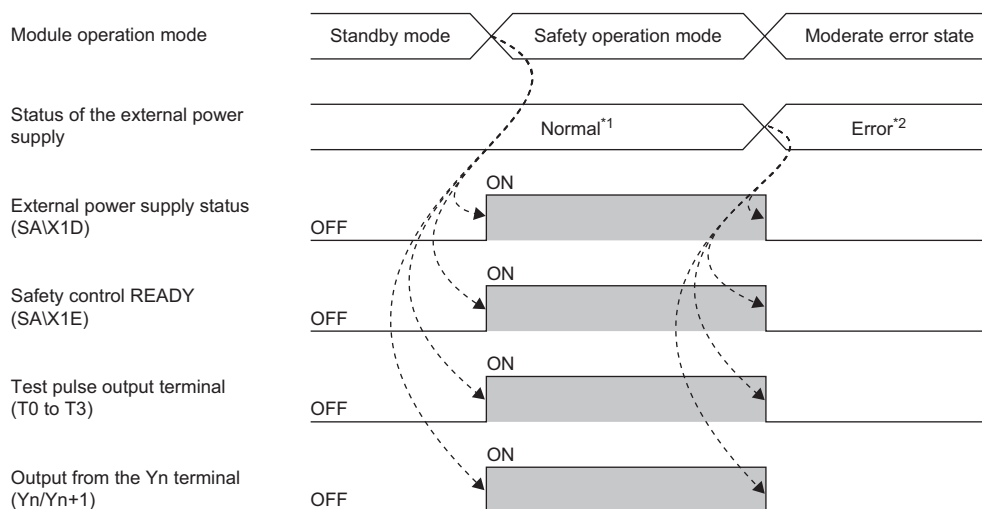

-----> Performed on the safety I/O module

*1 An external power supply voltage error has not occurred.

*2 An external power supply voltage error has occurred.

Continue safety I/O refresh (Without output interlock)

■ Output interlock

If safety outputs are turned off due to an external power supply voltage error detection, the outputs are interlocked.

If the outputs are interlocked, the safety control stops and the outputs from the Yn terminal and the test pulse output terminals are turned off.

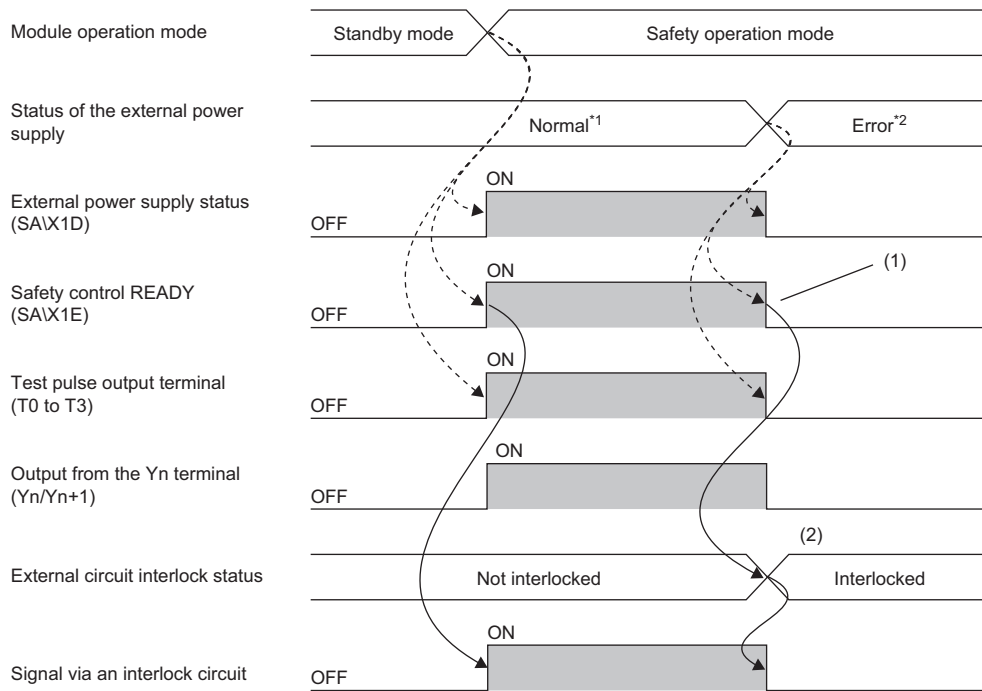

(1) If an external power supply voltage error occurs, 'Safety control READY' (SAIX1E) turns off and safety outputs and test pulses stop.

(2) Interlock operation

-----> Performed on the safety I/O module

—————> Performed by the customer on an external circuit

*1 An external power supply voltage error has not occurred.

*2 An external power supply voltage error has occurred.

■ Output interlock cancellation

After causes of an external power supply voltage error are eliminated, the safety control restarts and safety outputs and test pulse outputs restart.

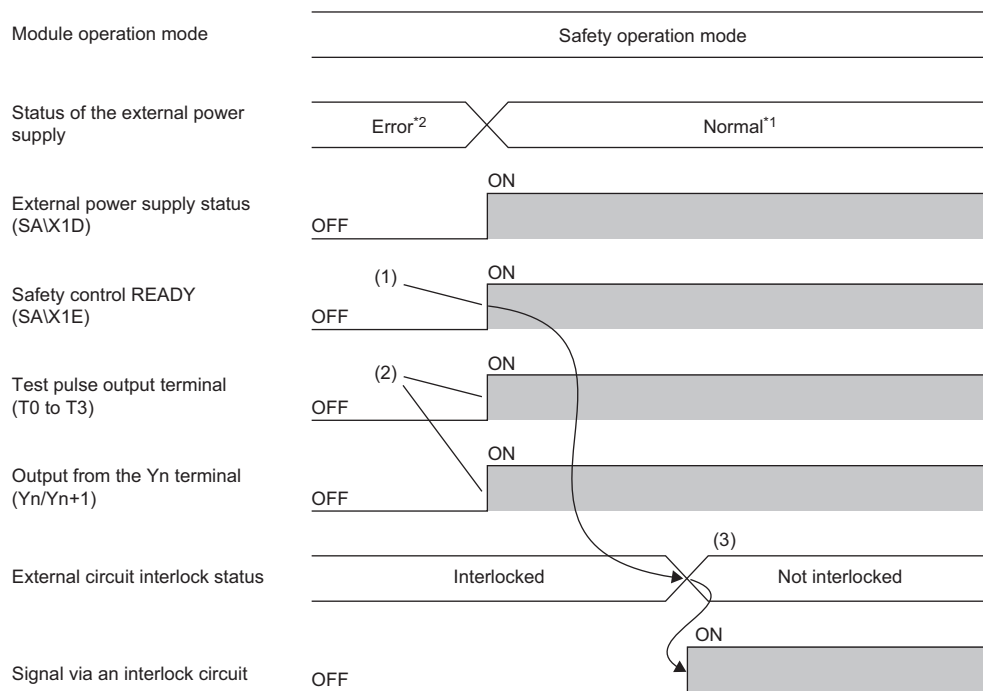

(1) When an external power supply voltage error is cleared, 'Safety control READY' (SAIX1E) turns on.

(2) After 'Safety control READY' (SAIX1E) turns on, safety outputs and test pulse outputs restart.

(3) Operation to release the interlock

—————> Performed by the customer on an external circuit

*1 An external power supply voltage error has not occurred.

*2 An external power supply voltage error has occurred.

Continue safety I/O refresh (With output interlock)

■Output interlock

If module operation mode is switched from standby mode to safety operation mode or if safety outputs are turned off due to an external power supply voltage error detection, the outputs are interlocked.

If the outputs are interlocked, the safety control stops and the outputs from the Yn terminal and the test pulse output terminals are turned off.

The safety control does not start until a restart instruction is sent via a safety control interlock cancellation signal.

This prevents an incorrect output before completion of checking safety in the working area and an incorrect output due to unintended recovery of the external power supply.

■When the module shifts to the safety operation mode

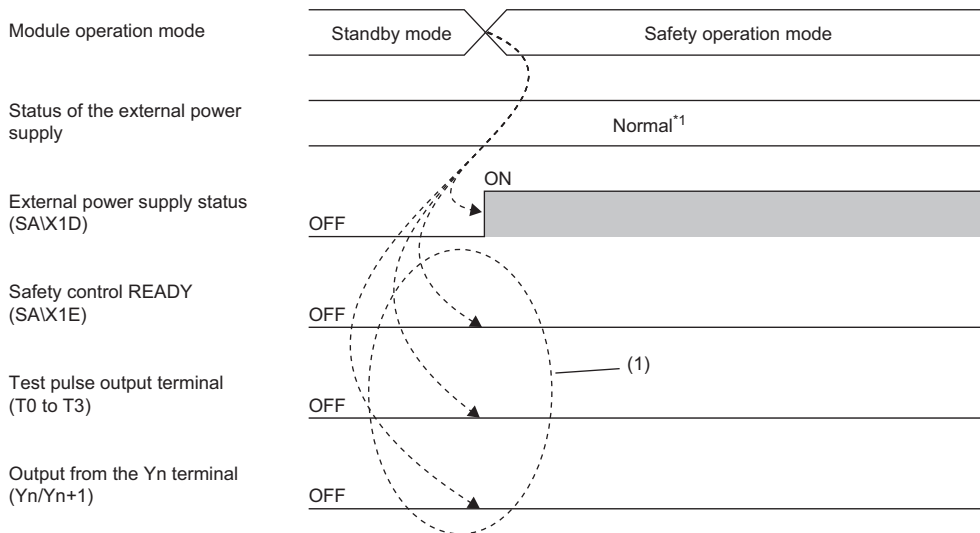

(1) Outputs are interlocked and each signal remains off.

-----> Performed on the safety I/O module

*1 An external power supply voltage error has not occurred.

■When an external power supply voltage error has occurred

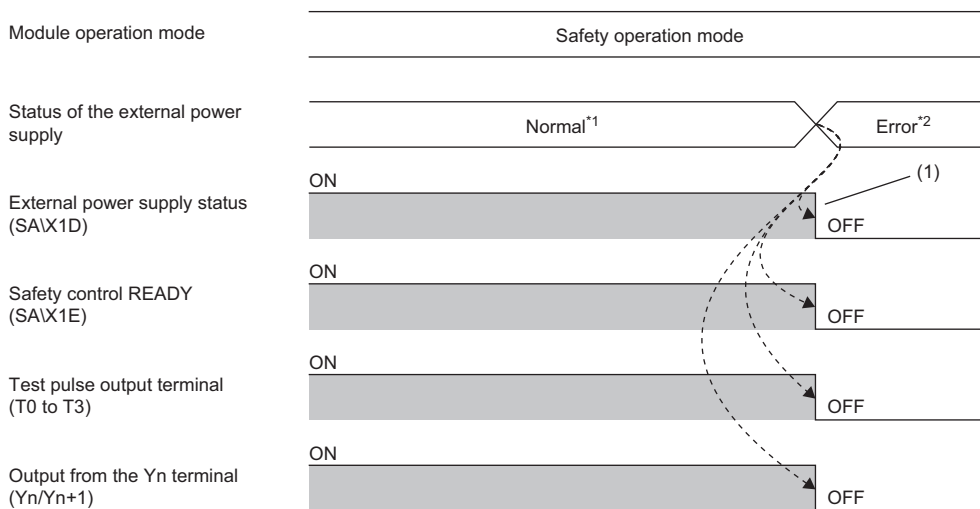

(1) If an external power supply voltage error occurs, 'Safety control READY' (SAIX1E) turns off and safety outputs and test pulse outputs stop.

-----> Performed on the safety I/O module

*1 An external power supply voltage error has not occurred.

*2 An external power supply voltage error has occurred.

■ Output interlock cancellation

After causes of an external power supply voltage error are eliminated, the safety control restarts through the output interlock cancellation operation performed via the safety control interlock cancellation signal.

Operating procedure

1. After checking that 'External power supply status' (SAIX1D) is on, turn on 'Safety control initial processing request flag' (SAIY1E).
2. After checking that 'Safety control initial processing completion flag' (SAIX1F) is on, turn off 'Safety control initial processing request flag' (SAIY1E).
3. After checking that 'Safety control initial processing completion flag' (SAIX1F) is off, turn on 'Safety control start flag' (SAIY1F).
4. After checking that 'Safety control READY' (SAIX1E) is on, turn off 'Safety control start flag' (SAIY1F).
5. After checking that 'Safety control READY' (SAIX1E) is on, turn on Safety output signal so that Output signal turns on.

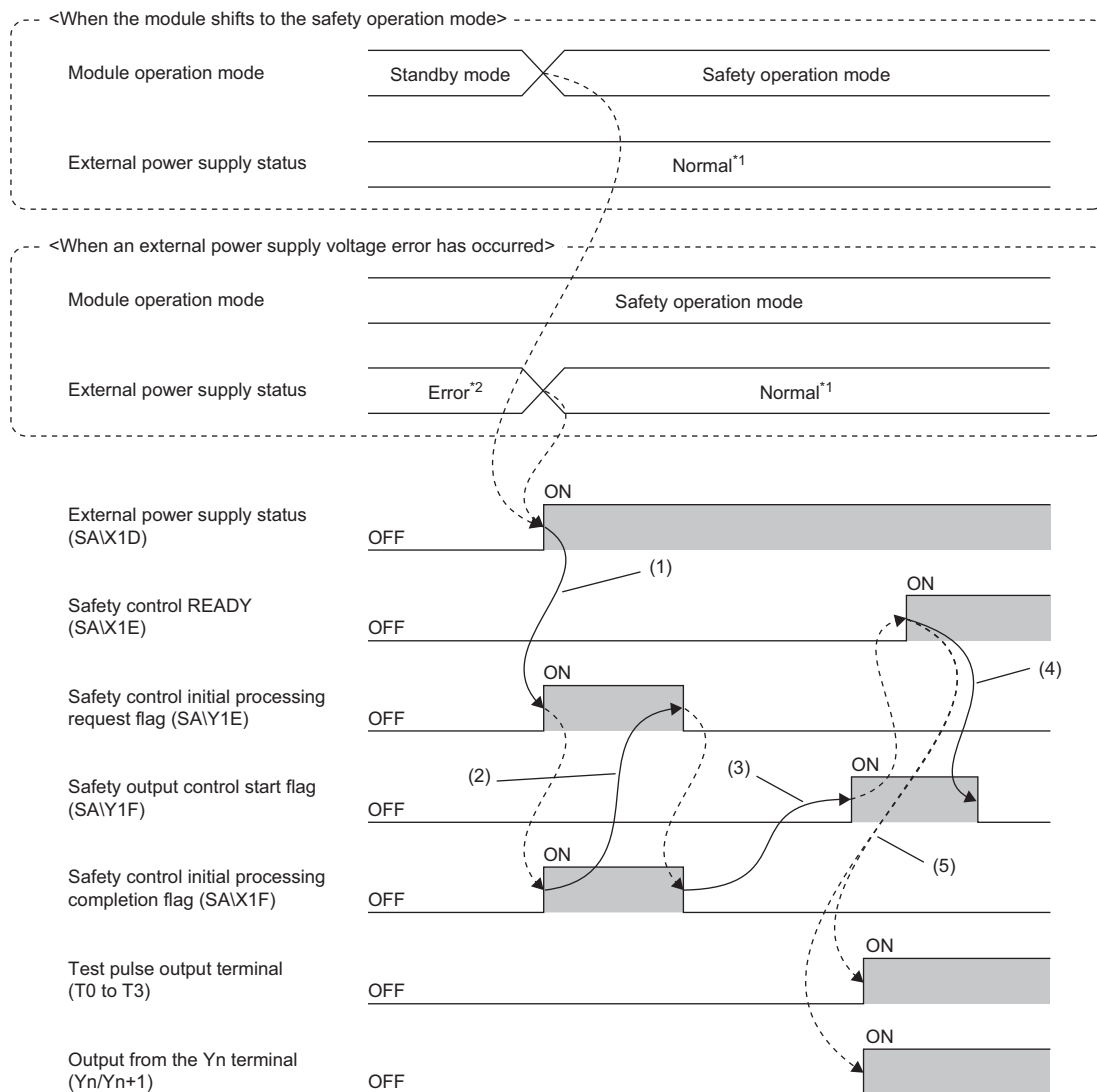

- (1) After checking that 'External power supply status' (SAIX1D) is on, turn on 'Safety control initial processing request flag' (SAIY1E) so that 'Safety control initial processing completion flag' (SAIX1F) turns on.
- (2) After checking that 'Safety control initial processing completion flag' (SAIX1F) is on, turn off 'Safety control initial processing request flag' (SAIY1E) so that 'Safety control initial processing completion flag' (SAIX1F) turns off.
- (3) After checking that 'Safety control initial processing completion flag' (SAIX1F) is off, turn on 'Safety control start flag' (SAIY1F) so that 'Safety control READY' (SAIX1E) turns on.
- (4) After checking that 'Safety control READY' (SAIX1E) is on, turn off 'Safety control start flag' (SAIY1F).
- (5) 'Safety control READY' (SAIX1E) turns on, and safety outputs and test pulse outputs start.



-----> Performed on the safety I/O module

—————> Performed by the customer on a program

- *1 An external power supply voltage error has not occurred.
- *2 An external power supply voltage error has occurred.

Setting method

 [Navigation window] ⇒ [Parameter] ⇒ [Module Information] ⇒ Module model name ⇒ [Application setting] ⇒ [Operation setting function of external power supply voltage error detection]

Item	Description	Reference
Operation setting of external power supply voltage error detection*1	Set the operation of the safety I/O refresh function when an external power supply voltage error occurs.	<ul style="list-style-type: none">  Page 41 Operation setting function of external power supply voltage error detection  Page 46 Operation setting function of external power supply voltage error detection

*1 When "Operation setting of external power supply voltage error detection" in "Application setting" is set to "Safety I/O refresh continues (With output interlock)", set "Number of points" of "Safety I/O refresh device setting" as follows.

Module	Item		Setting value
Safety input module	Safety I/O refresh device setting	Input module with safety functions to Safety CPU	Number of points ■Bit device (SAIX, SAIM, SAIB) • 32 points ■Word device (SAID, SAIW) • 2 points (Default: 32 points)
		Safety CPU to Input module with safety functions	■Bit device (SAIY, SAIM, SAIB) • 32 points ■Word device (SAID, SAIW) • 2 points (Default: 16 points)
Safety output module		Output module with safety functions to Safety CPU	■Bit device (SAIX, SAIM, SAIB) • 32 points ■Word device (SAID, SAIW) • 2 points (Default: 16 points)
		Safety CPU to Output module with safety functions	■Bit device (SAIY, SAIM, SAIB) • 32 points ■Word device (SAID, SAIW) • 2 points (Default: 16 points)

8.8 I/O LED Indication Setting Function on Error Condition

Users can select the indication method of the I/O status indicator LED when an error occurs.



When this function is enabled, only the I/O status indicator LED where an error has occurred flashes, and other I/O status indicator LEDs are off.

I/O where an error has occurred can be identified by the ERR LED and I/O status indicator LED.

When the error is cleared, the normal input status indication returns.

Setting method

 [Navigation window] ⇒ [Parameter] ⇒ [Module Information] ⇒ Module model name ⇒ [Application setting] ⇒ [I/O LED indication setting function on error condition]

Item	Description	Reference
I/O LED indication setting on error condition	Set the LED indication method on error condition.	 Page 41 I/O LED indication setting function on error condition  Page 46 I/O LED indication setting function on error condition

Precautions

When a hardware failure (error code: 3E00H to 3E0BH) or a self-diagnostic error (error code: 3004H, 3005H) occurs under the condition that the I/O status indicator LED of an input or output point is flashing due to an error, the I/O status indicator LED of the error point may stop even if "I/O LED indication setting function on error condition" is enabled,

9 MAINTENANCE AND INSPECTION

This chapter describes maintenance and inspection of the safety I/O module.

Point 

Read [Startup and Maintenance Precautions] in the safety precautions carefully before performing the inspection, and observe the precautions.

9.1 Daily Inspection

The following table lists the items that must be inspected on a daily basis.

Item	Inspection Item	Inspection method	Judgment criteria	Corrective action	
1	Mounting of the base unit	Loose	Check that mounting screws are not loose and the cover is not dislocated.	The screws and cover must be fixed.	Retighten the screws.
2	Mounting of the module	Loose	Check that the module is mounted and the module fixing hook is fixed securely.	The module must be mounted and the module fixing hook must be fixed.	Fix the module fixing hook securely.
3	Connection status	Terminal screw loosening	Check for the terminal screw loosening.	The terminal screws must not be loose.	Retighten the terminal screws.
		Clearance between the ferrules	Check for the clearance between the ferrules.	The proper clearance must be provided between solderless terminals.	Provide the proper clearance.
4	LED status	RUN LED	Check that the LED is on.	The LED must be on.	Refer to the following and take corrective actions.  Page 83 Troubleshooting with the LEDs
		ERR LED	Check that the LED is off.	The LED must be off.	
		SAFETY LED	Check that the LED is on.	The LED must be on.	
		Input status indicator LED	Check that the LED is on or off.	The LED must be on when an input is on. ^{*1} The LED must be off when an input is off. ^{*1}	
		Output status indicator LED	Check that the LED is on or off.	The LED must be on when an output is on. ^{*1} The LED must be off when an output is off. ^{*1}	

*1 These criteria are used when "I/O LED indication setting on error condition" is set to "No indication of error point". ( Page 80 I/O LED Indication Setting Function on Error Condition)

9.2 Periodic Inspection

This section describes items that must be inspected one or two times every six months to one year. When the equipment has been relocated or modified, or cable laying has been changed, inspect the module for the items.

Item	Inspection Item	Inspection method	Judgment criteria	Corrective action	
1	Environment	Ambient temperature ^{*1}	Measure the temperature by using a thermometer.	0 to 55°C	Create the environment that satisfies the judgment criteria
		Ambient humidity	Measure the humidity by using a hygrometer.	5 to 95%RH	
		Atmosphere	Measure corrosive gases.	No corrosive gases	
2	Module power supply voltage check	Measure a voltage between the terminals of 100/240VAC and 24VDC.	85 to 264VAC	Change the supply power.	
			15.6 to 31.2VDC		
3	Installation	Looseness and rattling	Touch the module to check for the looseness and rattling.	The module must be mounted securely.	Retighten the screws. If the module is loose, fix the module with screws.
		Attachment of dirt and foreign matter	Check visually.	Dirt and foreign matter must not be attached.	Remove them. Clean the programmable controller.
4	Connection status	Terminal screw loosening	Check for the terminal screw loosening.	The terminal screws must not be loose.	Retighten the screws.
		Clearance between the ferrules	Check for the clearance between the ferrules.	The proper clearance must be provided between solderless terminals.	Provide the proper clearance.

*1 The temperature in the control panel installed a programmable controller is called the ambient temperature.

10 TROUBLESHOOTING

This chapter describes the troubleshooting of the safety I/O module.

10.1 Troubleshooting with the LEDs

10

This section describes how to troubleshoot the system by the LEDs.

Depending on the LED status of the RUN LED, ERR LED, or SAFETY LED, the error status can be judged as follows.

RUN LED	ERR LED	SAFETY LED	Error status ^{*1}	Reference
Off ^{*2}	Flashing (400ms cycles) ^{*3}	Off ^{*2}	Major error	☞ Page 93 List of Error Codes
On	Flashing (400ms cycles)	— ^{*4}	Moderate error	
On	On	— ^{*5}	Minor error	

*1 When multiple errors have occurred, the error statuses are displayed in the order of error severity (Major error > Moderate error > Minor error).

*2 When the module has failed, the LED may not turn off.

*3 When the module has failed, the LED may not flash.

*4 Either of Flashing or Off.

*5 Any of On, Flashing, or Off.

When the RUN LED does not turn on

When the RUN LED does not turn on, check the following items.

Check item	Corrective action
Check whether the power is supplied.	Check that the supply voltage to the power supply module is within the rated range.
Check whether the module is mounted properly.	Mount the module properly.
Check whether the capacity of the power supply module is enough.	Calculate the current consumption of mounted modules, such as the Safety CPU, safety I/O module, and intelligent function modules to check that the power capacity is enough.
Cases other than the above	Reset the Safety CPU or turn off and on the power to the programmable controller, and check whether the RUN LED turns on. If the RUN LED still remains off, the possible cause is a failure of the module. Please consult your local Mitsubishi representative.

When the ERR LED turns on or flashes

When the ERR LED turns on or flashes, check the following item.

Check item	Corrective action
Check whether any error has occurred.	Check the error code in the "Module Diagnostics" window of the engineering tool and take the action described in the list of error codes. ☞ Page 93 List of Error Codes



When the SAFETY LED flashes

When the SAFETY LED flashes, check the following items.

Check item	Corrective action
Check whether the safety module position check has been executed. (Check whether "Safety Module Position Check Execution Status" has become "Executing" in Safety Module Operation of the engineering tool.)	In the "Safety Module Operation" window of the engineering tool, select the relevant module and select "SAFETY LED Stop Flashing".
Check whether the Safety CPU has been reset or the power to the programmable controller has been turned off and on after safety module validation was performed.	If safety module validation was performed, reset the Safety CPU or turn off and on the power to the programmable controller.

When the SAFETY LED turns off

When the SAFETY LED turns off, check the following items.

Check item	Corrective action
Has the safety module validation been performed?	Perform the safety module validation using the engineering tool.  Page 48 Safety Module Validation
Check whether an error has occurred in the safety I/O module.	Check the error code in the "Module Diagnostics" window of the engineering tool and take the action described in the list of error codes.  Page 93 List of Error Codes
Check whether any error has occurred in the Safety CPU.	Check the error code on the Safety CPU and take the corrective actions.
Check whether the safety I/O refresh interlock state of the Safety CPU has become interlocked.	Fully check wiring and connection, and cancel the interlocked state via an interlock release request for safety I/O refresh on the Safety CPU. For details on the safety I/O refresh interlock, refer to the manual for the Safety CPU used.
Check whether "System Parameter/CPU Parameter (Standard/Safety)" and "Module Parameter (Standard/Safety)" are simultaneously written when writing parameter settings to a Safety CPU.	Simultaneously write "System Parameter/CPU Parameter (Standard/Safety)" and "Module Parameter (Standard/Safety)" to a Safety CPU.

10.2 Checking the State of the Module

This section describes how to troubleshoot the system by the engineering tool.

Module diagnostics

The following can be checked in the "Module Diagnostics" window of the safety I/O module.

Item	Description
"Error Information" tab	Displays the description of errors that have occurred and actions to take.
"Module Information List" tab	Indicates various status information of the safety I/O module.

Error Information

The description of errors that have occurred and actions to take are displayed in the "Error Information" tab.

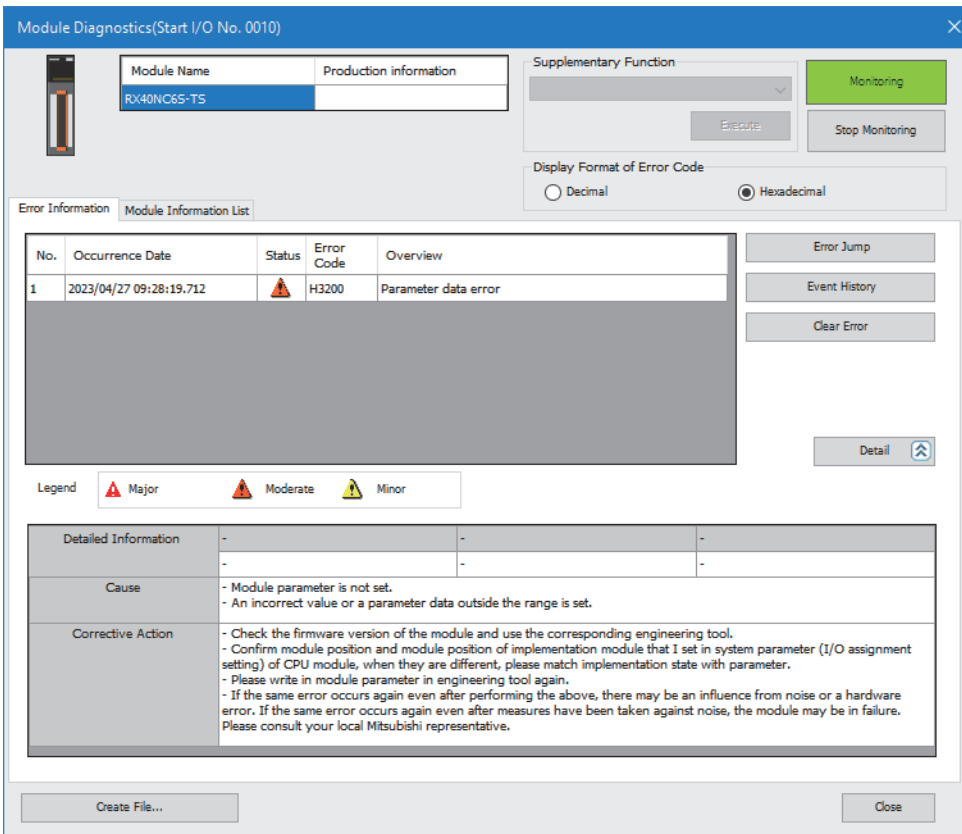

Item	Description
Status	Major: Error because of which the module stops, such as a hardware failure or memory failure.
	Moderate: Error because of which the module stops, such as a parameter error related to module operation.
	Minor: Error after which the module continues its operation, such as a communication failure.
Error code	☞ Page 93 List of Error Codes
[Event history] button	Clicking it displays the history of the errors detected and the operations executed. (☞ Page 96 List of Event Codes)
Detailed Information	Displays detailed information about each error (maximum of 3 pieces).
Cause	Displays the detailed error causes.
Corrective Action	Displays the actions to eliminate the error causes.

Restriction

Errors of the safety I/O module cannot be cleared using the [Clear Error] button.

For the error clear method, refer to the following.

☞ Page 94 List of error codes

Module Information List

Various status information of the safety I/O module is displayed in the "Module Information List" tab.

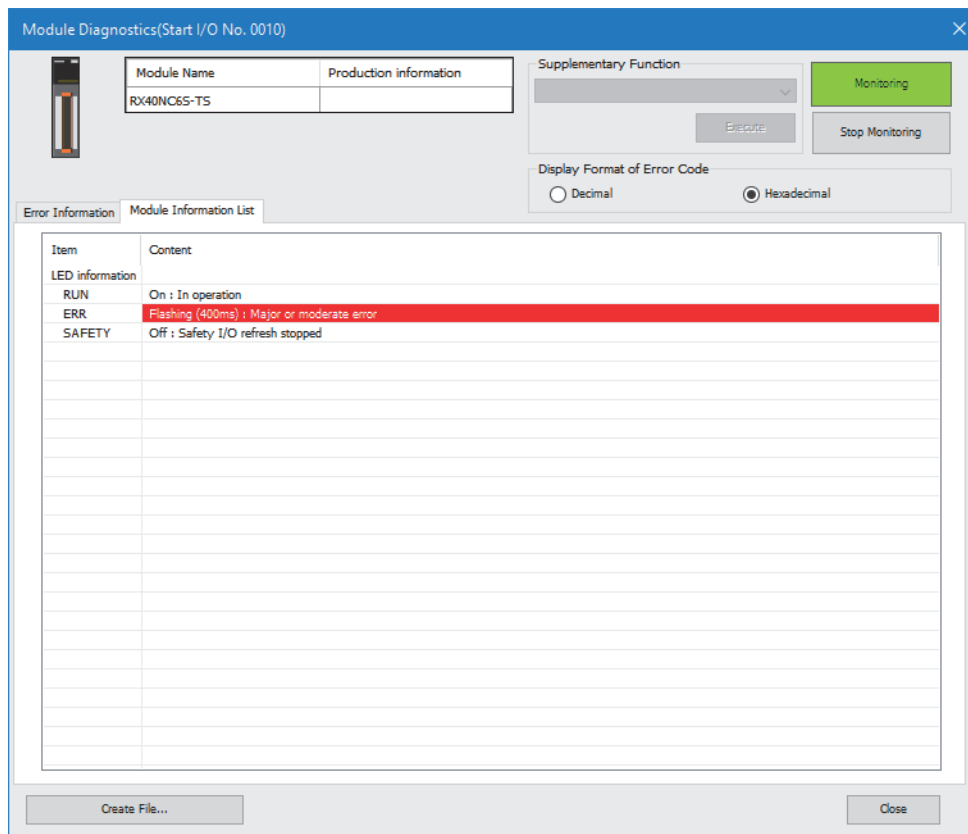

Item	Description
LED information	Indicates the LED status of the safety I/O module.

10.3 Troubleshooting by Symptom

This section describes troubleshooting for each phenomenon.

When the ON/OFF status of an external input cannot be read

When the ON/OFF status of an external input cannot be read, check the following items.

Check item	Corrective action
Is the SAFETY LED on?	Refer to the following and take corrective actions. ☞ Page 83 When the SAFETY LED flashes ☞ Page 84 When the SAFETY LED turns off
Is the corresponding input status indicator LED on when an external input signal is on?	If the LED does not turn on, there is a problem on the input wiring. Take the following actions. <ul style="list-style-type: none"> • Check the wiring confirming that the input wiring is not disconnected or short-circuited, or the voltage of the input signal is correct. • For the rated input voltage, refer to the following. ☞ Page 17 Performance Specifications
Is the setting of the safety I/O refresh device correct?	If a safety device different from the safety device assigned by the safety I/O refresh device setting is referred to, safety input cannot be read correctly. Check and correct the safety I/O refresh device setting so that it matches the setting in the program. For details on the safety I/O refresh device setting, refer to the following. ☞ Page 54 Safety I/O Refresh Function
Is there any incorrect setting in the wiring selection of input?	Review the settings in the wiring selection of input. For details on the setting related to the wiring selection of input, refer to the following. ☞ Page 59 Safety Input Function
Are the two signals in the double input wiring mismatched?	When "Wiring selection of input" is set to "Double wiring (NC/NC)", the safety input is different from the actual input signal level while the signal levels of the two paired inputs are mismatched. Check whether the external input device has failed or the external input terminal is wired incorrectly.

When the ON/OFF status of an external output cannot be changed

When the ON/OFF status of an external output cannot be changed, check the following items.

Check item	Corrective action
Is the SAFETY LED on?	Refer to the following and take corrective actions. ☞ Page 83 When the SAFETY LED flashes ☞ Page 84 When the SAFETY LED turns off
Is the corresponding output status indicator LED on when a safety output signal is on?	If the LED is on, a problem with the wiring exists between the external output terminal and external output device. Check the wiring for any disconnection or short-circuit.
Is the setting of the safety I/O refresh device correct?	If a safety device different from the safety device assigned by the safety I/O refresh device setting is referred to, safety output cannot be output correctly. Check and correct the safety I/O refresh device setting so that it matches the setting in the program. For details on the safety I/O refresh device setting, refer to the following. ☞ Page 54 Safety I/O Refresh Function
Is there any incorrect setting in the wiring selection of output?	Review the settings in the wiring selection of output. For details on the setting related to the wiring selection of output, refer to the following. ☞ Page 63 Safety Output Function
Are the outputs interlocked?	When "Operation setting of external power supply voltage error detection" in the application settings is set to "Safety I/O refresh continues (With output interlock)", check whether the outputs are interlocked. To check whether the outputs are interlocked or not, refer to the following. ☞ Page 77 Output interlock If the outputs are interlocked, cancel the output interlock by following the cancellation procedure. For the output interlock cancellation procedure, refer to the following. ☞ Page 78 Output interlock cancellation

When External output ON signal intermittently turns off

When External output ON signal turns off intermittently, check the following items.

Check item	Corrective action
Is an output dark test being executed?	Check the specifications of the safety devices used, and correct the settings of the output dark test pulse OFF time setting and the number of pulse output for output dark test. For details on the setting related to the output dark test, refer to the following. ☞ Page 71 Output dark test function

10.4 Troubleshooting While Proceeding Procedures Before Operation

This section describes troubleshooting while proceeding procedures before operation.

Troubleshooting on the "Safety Module Operation" window

When the "Safety Module Operation" window cannot be opened

When the "Safety Module Operation" window cannot be opened, check the following.

Check item	Corrective action
Check whether "Type" of the project is set to RnSFCPU.	Select RnSFCPU by changing the project type/operation mode. For details on changing the project type/operation mode, refer to the following.  GX Works3 Operating Manual

When "Verification Failed" is displayed

When "Verification Failed" is displayed for "Module Status", check the following.

Check item	Corrective action
Check whether the project was written to the Safety CPU.	Write the project to the Safety CPU and reset the Safety CPU or turn off and on the power to the programmable controller.
Check whether the Safety CPU has been reset or the power to the programmable controller has been turned off and on after the project writing to the Safety CPU.	Reset the Safety CPU or turn off and on the power to the programmable controller.

When "Enabling Failed (Module Error)" is displayed

When "Enabling Failed (Module Error)" is displayed for "Module Status", check the following.

Check item	Corrective action
Check whether measures have been properly taken against noise.	Take measures to reduce noise since the system may be affected by noise. If measures to reduce noise do not eliminate this symptom, the possible cause is a failure of the module. Please consult your local Mitsubishi representative.

When "Timeout" is displayed

When "Timeout" is displayed for "Module Status" or "Safety Module Position Check Execution Status", check the following.

Check item	Corrective action
Check whether the safety I/O module has been properly mounted.	Check the "System Monitor" window of the engineering tool and the actual base unit to check whether the safety I/O module is mounted properly.
Check whether measures have been properly taken against noise.	Take measures to reduce noise since the system may be affected by noise. If measures to reduce noise do not eliminate this symptom, the possible cause is a failure of the module. Please consult your local Mitsubishi representative.

When "Processing Failed" is displayed

When "Processing Failed" is displayed for "Module Status" or "Safety Module Position Check Execution Status", check the following.

Check item	Corrective action
Check whether the safety I/O module has been properly mounted.	Check the "System Monitor" window of the engineering tool and the actual base unit to check whether the safety I/O module is mounted properly.
Check whether measures have been properly taken against noise.	Take measures to reduce noise since the system may be affected by noise. If measures to reduce noise do not eliminate this symptom, the possible cause is a failure of the module. Please consult your local Mitsubishi representative.

When "-" is displayed

When "-" is displayed for "Module Status" or "Safety Module Position Check Execution Status", check the following.

Check item	Corrective action
Check whether the safety I/O module has been properly mounted.	Check the "System Monitor" window of the engineering tool and the actual base unit to check whether the safety I/O module is mounted properly.
Check whether measures have been properly taken against noise.	Take measures to reduce noise since the system may be affected by noise. If measures to reduce noise do not eliminate this symptom, the possible cause is a failure of the module. Please consult your local Mitsubishi representative.

10.5 Fault Examples with the Safety I/O Module

Troubleshooting for input circuit

An input signal does not turn off

■Cause

Even if the switch with LED indicator is turned off, a leakage current exceeding the OFF current of the safety input module is generated.

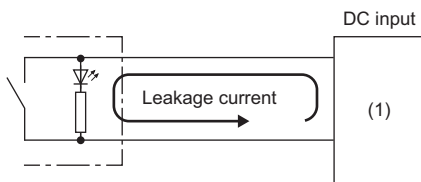

(1) Safety input module

■Corrective action

Connect an appropriate resistor as shown in the figure below so that the leakage current flowing into the safety input module falls below the OFF current.

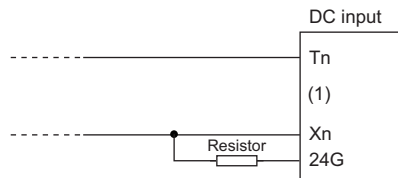

(1) Safety input module

■Calculation example (RX40NC6S-TS)

When the 24VDC external power supply of the safety input module is on and an LED indicator switch that has a leakage current of 3mA at a maximum is connected

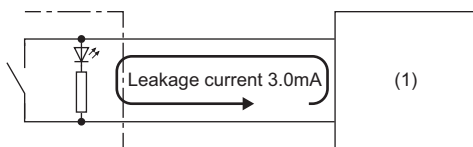

(1) Safety input module

- The leakage current through the safety input module does not satisfy the condition of the OFF current of 1.5mA or lower. To satisfy the condition, connect a resistor as shown in the figure below.

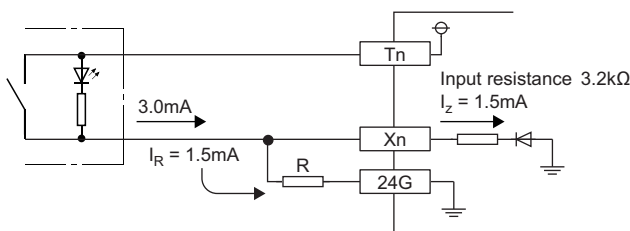

- To satisfy the condition of the OFF current of the safety input module (1.5mA or lower), the current through the connected resistor should be 1.5mA or higher. From the formula below, the connected resistor (R) is lower than or equal to 3.2kΩ.

$$I_R : I_z = Z (\text{Input resistance}) : R$$

$$R \leq \frac{I_z \times Z (\text{Input resistance})}{I_R} = \frac{1.5 \times 3.2}{1.5} = 3.2 \text{ [k}\Omega\text{]}$$

3. When the resistor (R) is 3.0kΩ, for example, the power capacity (W) of the resistor (R) becomes 0.28W.

$$W = \frac{(\text{Input voltage})^2}{R} = \frac{28.8^2}{3000} = 0.28 \text{ [W]}$$

4. Because the resistor requires a power capacity that is 3 to 5 times larger than the actual current consumption, the resistor connected to the terminal should be 3.0kΩ; and 1.0 to 1.5W.

A signal incorrectly inputs data

■Cause

Noise is taken as input data.

■Corrective action

- To prevent excessive noise, avoid installing power cables together with I/O cables.
- Set a longer input response time. (☞ Page 39 Input response time setting function)
- Take noise reduction measures such as connecting surge absorbers to noise-generating devices such as relays and contactors using the same power supply.
- To prevent noise from being taken in, take measures to reduce noise for the I/O cable by using a part such as a ferrite core.
- To prevent radiation noise to the I/O cable, take measures to reduce noise by using a shielded cable.

Troubleshooting for output circuit

A load momentarily turns on from off when the system is powered off

■Cause

When an inductive load is connected, the load [2] in the off state may turn on due to a sneak current from the back EMF at the shut-off [1].

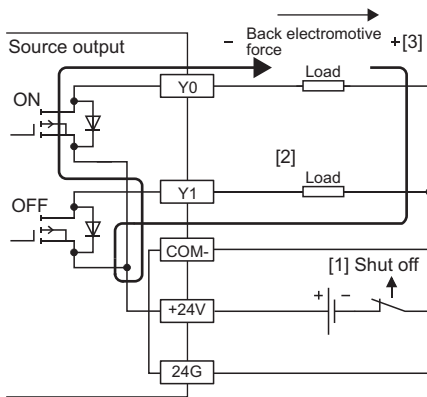

■Corrective action

Take either of the following two actions.

- To suppress the back EMF, connect a diode in parallel with the load under the back EMF influence [3].

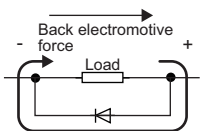

- Configure another current path by connecting a diode across positive and negative of the external power supply.

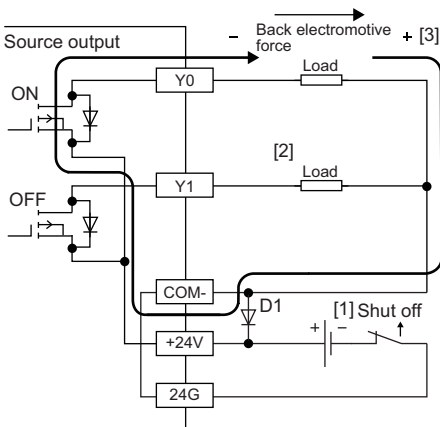

D1 indicates the following.

Reverse voltage VR (VRM)^{*1}

Forward current IF (IFM)^{*2}

*1 Approximately 10 times as high as the rated load voltage in the performance specifications

Example: 24VDC → Approximately 200VDC

*2 Twice as high as the maximum load current (common) in the performance specifications or more



Example: 2A/common → 4A or higher

10.6 List of Error Codes

This section describes the error codes of safety I/O module.

How to check error codes

The table below shows how to check error codes for errors that have occurred on a safety I/O module.

Checking method	Description
System monitor of an engineering tool	Error codes can be checked using the system monitor of an engineering tool. ( Page 85 Checking the State of the Module)
Buffer memory	The latest error codes can be checked in the monitoring area of the buffer memory. ( Page 105 Buffer Memory)

Error classification

Errors on safety I/O modules are classified as shown below.

Classification	Description
Major error	<ul style="list-style-type: none">• An error that cannot be recovered. The RUN LED turns off.• The safety functions (safety I/O, safety diagnostics, and safety I/O refresh) stop.
Moderate error	<ul style="list-style-type: none">• An error where the module cannot continue to operate. The ERR LED flashes.• The safety functions (safety I/O, safety diagnostics, and safety I/O refresh) stop and the SAFETY LED turns off.
Minor error	<ul style="list-style-type: none">• An error where the module can continue to operate. The ERR LED turns on.• The safety functions also keep operating. (If a safety I/O refresh error occurs, safety I/O and safety I/O refresh stop.)

List of error codes

The table below lists the error codes of safety I/O module.

Error code	Classification	Error name	Cause	Action
1800H	Minor	Double input discrepancy detection error	A double input discrepancy was detected in a pair of inputs (X0 and X1, X2 and X3, ...).	<ul style="list-style-type: none"> • Turn on the external power supply before turning on the programmable controller. • Correct the parameter settings of "Double input discrepancy detection time". • Review the connected devices and wiring. • When the connected devices and wiring have no errors, there may be an influence from noise. Take measures to reduce noise. • If the same error occurs again, the module may be in failure. Please consult your local Mitsubishi representative. • When "Double input discrepancy auto recovery setting" is set to "Used", the module will recover from this error after the double input discrepancy is eliminated.
1801H	Minor	Input dark test error	During an input dark test, test pulses were not detected.	<ul style="list-style-type: none"> • Turn on the external power supply before turning on the programmable controller. • Review the connected devices and wiring. • When the connected devices and wiring have no errors, there may be an influence from noise. Take measures to reduce noise. • Correct the parameter settings of "Input dark test pulse OFF time setting" and "Number of pulse output for input dark test". • If the same error occurs again, the module may be in failure. Please consult your local Mitsubishi representative.
1A00H to 1A02H	Minor	External power supply voltage error	An external power supply error was detected.	<ul style="list-style-type: none"> • Review the connected devices, wiring, and voltage. • Turn on the external power supply before turning on the programmable controller. • There may be an influence from noise of external wiring (such as power supply part and I/O signal part). Take measures to reduce noise. • If the same error occurs again, the module may be in failure. Please consult your local Mitsubishi representative.
1A03H to 1A09H	Minor	Safety I/O refresh error	Response monitoring timeout was detected during safety I/O refresh.	<ul style="list-style-type: none"> • Correct the set values for "Safety input refresh interval monitoring time", "Safety output refresh interval monitoring time", and "Safety I/O refresh timeout time" of the module parameters. Set module parameters and perform the safety module validation again according to the parameter setting procedure described in the manual. • When an error has occurred on the CPU module, check the error description for the CPU module and take corrective actions. • If the same error occurs again even after performing the above, there may be an influence from noise or a hardware failure. If the same error occurs again even after measures have been taken against noise, the module may be in failure. Please consult your local Mitsubishi representative.
3000H to 300DH	Moderate	Self-diagnostic error	An error was detected by the self-diagnostics.	<ul style="list-style-type: none"> • There may be an influence from noise or a hardware failure. Take measures to reduce noise. • If the same error occurs again even after measures have been taken against noise, the module may be in failure. Please consult your local Mitsubishi representative.
300EH	Moderate	Non-volatile memory data error	An error of the data stored in the non-volatile memory has been detected.	<ul style="list-style-type: none"> • Perform the safety module validation using the engineering tool and restart the module. • Take measures to reduce noise. If the same error occurs again, the module may be in failure. Please consult your local Mitsubishi representative.
300FH	Moderate	Non-volatile memory data error	An error of the data stored in the non-volatile memory has been detected.	<ul style="list-style-type: none"> • Restart the module. • If the same error occurs again even after performing the above, there may be an influence from noise or a hardware failure. If the same error occurs again even after measures have been taken against noise, the module may be in failure. Please consult your local Mitsubishi representative.
3010H	Moderate	Unsupported CPU error	The control CPU module does not support the safety I/O module.	Use a CPU module that supports the safety I/O module.
3200H	Moderate	Parameter data error	<ul style="list-style-type: none"> • No module parameters are set. • An incorrect value or parameter data out of the range is set. 	<ul style="list-style-type: none"> • Check the firmware version of the module and use a supported engineering tool. • Check the module position set in the system parameters (I/O assignment setting) of the Safety CPU and the position of the mounted module. If the positions do not match, correct them so that the module position in the parameters and the position of the mounted module are the same. • Write the module parameters by using the engineering tool again. • If the same error occurs again even after performing the above, there may be an influence from noise or a hardware failure. If the same error occurs again even after measures have been taken against noise, the module may be in failure. Please consult your local Mitsubishi representative.

Error code	Classification	Error name	Cause	Action
3264H	Moderate	Parameter data error (input response time)	An incorrect value or parameter data (input response time) out of the range is set.	<ul style="list-style-type: none"> • Correct the parameter setting for "Input response time". • Correct the parameter settings of "Input response time", "Number of pulse output for input dark test", and "Input dark test pulse OFF time setting" so that "Input response time" is longer than the input dark test pulse output time. Input dark test pulse output time = "Input dark test pulse OFF time setting" × ((Number of pulse output for input dark test" × 2) - 1) • If the same error occurs again even after performing the above, there may be an influence from noise or a hardware failure. If the same error occurs again even after measures have been taken against noise, the module may be in failure. Please consult your local Mitsubishi representative.
3400H	Moderate	Output read-back error	A discrepancy of an output read-back value and an output value was detected.	<ul style="list-style-type: none"> • Set "Wiring selection of output" for unused output terminals to "Not used". • Review the connected devices and wiring. • Check that 24VDC is supplied to the external power supply using a tester. • Check that the external connection is not overloaded. • When the connected devices and wiring have no errors, there may be an influence from noise or a hardware failure. Take measures to reduce noise. • If the same error occurs again, the module may be in failure. Please consult your local Mitsubishi representative.
3401H	Moderate	Output dark test error	During an output dark test, test pulses were not detected.	<ul style="list-style-type: none"> • Set "Wiring selection of output" for unused output terminals to "Not used". • Review the connected devices and wiring. • Check that 24VDC is supplied to the external power supply using a tester. • Check that the external connection is not overloaded. • Correct the parameter settings of "Output dark test pulse OFF time setting" and "Number of pulse output for output dark test". • When the connected devices and wiring have no errors, there may be an influence from noise or a hardware failure. Take measures to reduce noise. • Turn on the external power supply before turning on the programmable controller. • If the same error occurs again, the module may be in failure. Please consult your local Mitsubishi representative.
3500H	Moderate	Input internal dark test error	During an input internal dark test, test pulses were not detected.	<ul style="list-style-type: none"> • Review the connected devices and wiring. • When the connected devices and wiring have no errors, there may be an influence from noise or a hardware failure. Take measures to reduce noise. • Turn on the external power supply before turning on the programmable controller. • If the same error occurs again, the module may be in failure. Please consult your local Mitsubishi representative.
3600H to 3602H	Moderate	External power supply voltage error	An external power supply error was detected.	<ul style="list-style-type: none"> • Review the connected devices, wiring, and voltage. • Turn on the external power supply before turning on the programmable controller. • If the same error occurs again, the module may be in failure. Please consult your local Mitsubishi representative.
3603H to 3604H	Moderate	Module internal temperature error	An excessively high or low module internal temperature was detected.	<ul style="list-style-type: none"> • Check the ambient temperature of the module. If the ambient temperature is above the specifications (0 to 55°C), take measures so that the ambient temperature of the safety I/O module is within the specifications. • If the same error occurs again, the module may be in failure. Please consult your local Mitsubishi representative.
3605H	Moderate	Safety module invalid	Parameters were changed for the module for which safety module was validated.	Because the parameters were changed, perform the safety module validation.
3E00H to 3E0BH	Major	Hardware failure	A hardware error was detected.	<ul style="list-style-type: none"> • There may be an influence from noise or a hardware failure. Take measures to reduce noise. • If the same error occurs again even after measures have been taken against noise, the module may be in failure. Please consult your local Mitsubishi representative.

10.7 List of Event Codes

The table below shows events that occur in the safety I/O module.

Event code	Event type	Event category	Overview	Description
00152	System	Information	Safety I/O refresh start	Safety I/O refresh started.
00153	System	Information	Safety I/O refresh stop	Safety I/O refresh stopped.
00154	System	Information	Safety module validation successful	Safety parameter validation succeeded.
00A11	System	Warning	Safety module validation failure	Safety parameter validation failed.

APPENDICES

Appendix 1 I/O Signals

List of I/O signals

The tables below list the I/O signals of the safety I/O module. For details on the I/O signals, refer to the following.

 Page 99 Details of input signals

Point

- The following I/O signals (X, Y) are for when 0 is set for the start I/O number of the safety I/O module.
- Any "use prohibited" signals in the tables cannot be used (turned on/off) by users since they are used by the system. If these signals are used by the users, the functions of the safety I/O module cannot be guaranteed.

Safety input module

Signal direction: Safety input module → Safety CPU		Signal direction: Safety CPU → Safety input module	
Device number	Signal name	Device number	Signal name
X0	External input monitor signal X0	Y0	Use prohibited
X1	External input monitor signal X1	Y1	
X2	External input monitor signal X2	Y2	
X3	External input monitor signal X3	Y3	
X4	External input monitor signal X4	Y4	
X5	External input monitor signal X5	Y5	
X6	External input monitor signal X6	Y6	
X7	External input monitor signal X7	Y7	
X8	External input monitor signal X8	Y8	
X9	External input monitor signal X9	Y9	
XA	External input monitor signal XA	YA	
XB	External input monitor signal XB	YB	
XC	External input monitor signal XC	YC	
XD	External input monitor signal XD	YD	
XE	External input monitor signal XE	YE	
XF	External input monitor signal XF	YF	
X10	Use prohibited	Y10	
X11		Y11	
X12		Y12	
X13		Y13	
X14		Y14	
X15		Y15	
X16		Y16	
X17		Y17	
X18		Y18	
X19		Y19	
X1A		Y1A	
X1B		Y1B	
X1C		Y1C	
X1D		Y1D	
X1E	Y1E		
X1F	Module READY	Y1F	

A

Safety output module

Signal direction: Safety output module → Safety CPU		Signal direction: Safety CPU → Safety output module	
Device number	Signal name	Device number	Signal name
X0	Use prohibited	Y0	Use prohibited
X1			
X2			
X3			
X4			
X5			
X6			
X7			
X8			
X9			
XA			
XB			
XC			
XD			
XE			
XF			
X10			
X11			
X12			
X13			
X14			
X15			
X16			
X17			
X18			
X19			
X1A			
X1B			
X1C			
X1D			
X1E			
X1F	Module READY	Y1F	

Details of input signals

This section describes the details on the input signals of the safety I/O module to the Safety CPU.
The input signals (X) in this section are for when 0 is set for the start I/O number of the safety I/O module.

External input monitor signal

These signals indicate the ON/OFF state of the external input terminals. By monitoring the actual signals of the external input, a double input discrepancy detection error can be troubleshooted easily when it occurs.

■Device number

Signal name	Device number
External input monitor signal	X0 to XF

Point

- Do not use the external input monitor signals for the safety programs because they are used for investigating the cause of a double input discrepancy error.
- This function is enabled for input terminals where "Not used" is set for "Wiring selection of input" in the basic settings.
- When a major error or moderate error occurs, external input monitor signals (X0 to XF) turn off regardless of the signal state of the external input terminals.

Module READY

This signal is used for read interlock of the buffer memory and external input monitor signals.

Module READY (X1F) turns on after the power of the Safety CPU is turned on or reset, and Module READY turns off upon completion of the initial processing of the safety I/O module.

When a watchdog timer error occurs, Module READY turns on.

■Device number

Signal name	Device number
Module READY	X1F

Appendix 2 Safety I/O Signals

List of safety I/O signals

The tables below list the safety I/O signals of the safety I/O module.

For details on the safety I/O signals, refer to the following.

☞ Page 102 Details of safety input signals, ☞ Page 104 Details of safety output signals

Point

- The following safety I/O signals (SAIX, SAIY) are for when 0 is set for the start address of the device in "Safety I/O refresh device setting".
- Any "use prohibited" signals in the tables cannot be used (turned on/off) by users since they are used by the system. If these signals are used by the users, the functions of the safety I/O module cannot be guaranteed.

Safety input module

Signal direction: Safety input module → Safety CPU		Signal direction: Safety CPU → Safety input module	
Device number	Signal name	Device number	Signal name
SAIX0	Safety input signal X0	SAIY0	Use prohibited
SAIX1	Safety input signal X1	SAIY1	
SAIX2	Safety input signal X2	SAIY2	
SAIX3	Safety input signal X3	SAIY3	
SAIX4	Safety input signal X4	SAIY4	
SAIX5	Safety input signal X5	SAIY5	
SAIX6	Safety input signal X6	SAIY6	
SAIX7	Safety input signal X7	SAIY7	
SAIX8	Safety input signal X8	SAIY8	
SAIX9	Safety input signal X9	SAIY9	
SAIXA	Safety input signal XA	SAIYA	
SAIXB	Safety input signal XB	SAIYB	
SAIXC	Safety input signal XC	SAIYC	
SAIXD	Safety input signal XD	SAIYD	
SAIXE	Safety input signal XE	SAIYE	
SAIXF	Safety input signal XF	SAIYF	
SAIX10	Double input discrepancy state X0 X1	SAIY10	
SAIX11	Double input discrepancy state X2 X3	SAIY11	
SAIX12	Double input discrepancy state X4 X5	SAIY12	
SAIX13	Double input discrepancy state X6 X7	SAIY13	
SAIX14	Double input discrepancy state X8 X9	SAIY14	
SAIX15	Double input discrepancy state XA XB	SAIY15	
SAIX16	Double input discrepancy state XC XD	SAIY16	
SAIX17	Double input discrepancy state XE XF	SAIY17	
SAIX18	Use prohibited	SAIY18	
SAIX19		SAIY19	
SAIX1A		SAIY1A	
SAIX1B		SAIY1B	
SAIX1C		SAIY1C	
SAIX1D	External power supply status	SAIY1D	
SAIX1E	Safety control READY	SAIY1E	Safety control initial processing request flag ^{*1}
SAIX1F	Safety control initial processing completion flag ^{*1}	SAIY1F	Safety control start flag ^{*1}

*1 These signals are used only when "Operation setting of external power supply voltage error detection" in the application settings is set to "Safety I/O refresh continues (With output interlock)".

Safety output module

Signal direction: Safety output module → Safety CPU		Signal direction: Safety CPU → Safety output module	
Device number	Signal name	Device number	Signal name
SAIX0	Safety control READY	SAIY0	Safety output signal Y0
SAIX1	Use prohibited	SAIY1	Safety output signal Y1
SAIX2		SAIY2	Safety output signal Y2
SAIX3		SAIY3	Safety output signal Y3
SAIX4		SAIY4	Safety output signal Y4
SAIX5		SAIY5	Safety output signal Y5
SAIX6		SAIY6	Safety output signal Y6
SAIX7		SAIY7	Safety output signal Y7
SAIX8		SAIY8	Use prohibited
SAIX9		SAIY9	
SAIXA		SAIYA	
SAIXB		SAIYB	
SAIXC		SAIYC	
SAIXD		SAIYD	
SAIXE		SAIYE	
SAIXF		SAIYF	
SAIX10		SAIY10	
SAIX11		SAIY11	
SAIX12		SAIY12	
SAIX13	SAIY13		
SAIX14	SAIY14		
SAIX15	SAIY15		
SAIX16	SAIY16		
SAIX17	SAIY17		
SAIX18	SAIY18		
SAIX19	SAIY19		
SAIX1A	SAIY1A		
SAIX1B	SAIY1B		
SAIX1C	SAIY1C		
SAIX1D	External power supply status	SAIY1D	
SAIX1E	Safety control READY	SAIY1E	Safety control initial processing request flag ^{*1}
SAIX1F	Safety control initial processing completion flag ^{*1}	SAIY1F	Safety control start flag ^{*1}

*1 These signals are used only when "Operation setting of external power supply voltage error detection" in the application settings is set to "Safety I/O refresh continues (With output interlock)".

Details of safety input signals

This section describes the details on the safety input signals of the safety I/O module to the Safety CPU.

The safety input signals (SA\X) in this section are for when 0 is set for the start address of the device in "Safety I/O refresh device setting".

Safety input signals

These input signals are used for safety control. The signals show the on or off state of the external input (X0 to XF) of the safety input module.

When the double wiring function or the input response time setting function is enabled, the on/off status of 'Safety input signal X0' (SA\X0) to 'Safety input signal XF' (SA\XF) and that of the actual external inputs (X0 to XF) may differ.

For details on the safety input functions, refer to the following.

 Page 59 Safety Input Function

■Device number

Signal name	Device number
Safety input signal X0 to XF	SA\X0 to SA\XF

Double input discrepancy state

This signal stores the double input discrepancy detection state. It turns on when a double input discrepancy detection error has occurred in a pair of the corresponding input signals.

■Device number

Signal name	Device number
Double input discrepancy state X0 X1 to Double input discrepancy state XE XF	SA\X10 to SA\X17

External power supply status

This signal indicates the external power supply status.

When "Operation setting of external power supply voltage error detection" in the application settings is set to "Safety I/O refresh continues (Without output interlock)", the signal is also used as the condition to cancel the interlock by an external circuit.

When "Operation setting of external power supply voltage error detection" in the application settings is set to "Safety I/O refresh continues (With output interlock)", the signal is also used as the condition to cancel the interlock and operate relevant flags to restart the safety control.

For the operation of flags, refer to the following.

 Page 74 Operation Setting Function at Detection of External Power Supply Voltage Error

■Device number

Signal name	Device number
External power supply status	SA\X1D

Safety control READY

This signal indicates that the safety control is enabled. The ON/OFF state of the safety control is indicated.

It turns ON when all the following conditions are met.

- During safety operation mode*¹
- When the external power supply is normal state
- When the operation of flags*² to restart the safety control is completed

When "Operation setting of external power supply voltage error detection" in the application settings is set to "Safety I/O refresh continues (Without output interlock)", use the signal as the condition to cancel the interlock by an external interlock circuit.

*1 For details on the safety operation mode, refer to the following.

☞ Page 26 Operation mode and state transition

*2 The operation of flags is required when "Operation setting of external power supply voltage error detection" in the application settings is set to "Safety I/O refresh continues (With output interlock)".

For the operation of flags, refer to the following.

☞ Page 74 Operation Setting Function at Detection of External Power Supply Voltage Error

■Device number

Signal name	Device number
Safety control READY	SAIX0, SAIX1E

Point

SAIX0 and SAIX1E are the same signal. When replacing a CC-Link IE TSN remote I/O module (with safety functions) with a safety output module, using SAIX1E can eliminate the need to change the program.

Safety control interlock cancellation signal

After causes of the external power supply voltage error are eliminated, the safety program uses these control signals to cancel the safety output interlock. The control signals are as follows:

- 'Safety control initial processing completion flag' (SAIX1F)
- 'Safety control initial processing request flag' (SAIY1E)
- 'Safety control start flag' (SAIY1F)

For how to use the signals, refer to the following.

☞ Page 74 Operation Setting Function at Detection of External Power Supply Voltage Error

Point

These signals are used only when "Operation setting of external power supply voltage error detection" in the application settings is set to "Safety I/O refresh continues (With output interlock)".

Details of safety output signals

This section describes the details on the safety output signals of the safety I/O module to the Safety CPU.

The safety output signals (SA\Y) in this section are for when 0 is set for the start address of the device in "Safety I/O refresh device setting".

Safety output signals

These output signals are used for safety control.

The signals show the on or off state that is output to the external terminals (Y0 to Y7) of the safety output module.

When the double wiring function is enabled, the on/off status of 'Safety output signal Y0' (SA\Y0) to 'Safety output signal Y7' (SA\Y7) and that of the actual external outputs (Y0 to Y7) may differ.

For details on the safety output functions, refer to the following.

 Page 63 Safety Output Function

■Device number

Signal name	Device number
Safety output signal Y0 to Y7	SA\Y0 to SA\Y7

Appendix 3 Buffer Memory

List of buffer memory assignments

The tables below list the buffer memory areas of the safety I/O module.

For details on the buffer memory areas, refer to the following.

 Page 107 Details of buffer memory addresses

Point

- The buffer memory in the safety I/O module is only for monitor data (used for referring to the status of the safety I/O module). Only reading data is possible and writing data is not allowed.
- Do not write any data to the buffer memory. If data is written, the correct operation of the safety I/O module cannot be guaranteed.

Address (decimal)	Address (hexadecimal)	Area
0 to 255	0000H to 00FFH	Error history area
256 to 1791	0100H to 06FFH	Monitoring area

Error history area

Address (decimal)	Address (hexadecimal)	Description	Default value	Read/Write ^{*1}
0	0000H	Latest address of error history	0000H	R
1 to 15	0001H to 000FH	System area	—	—
16 to 23	0010H to 0017H	Error history 1	0000H	R
24 to 31	0018H to 001FH	Error history 2	0000H	R
32 to 39	0020H to 0027H	Error history 3	0000H	R
40 to 47	0028H to 002FH	Error history 4	0000H	R
48 to 55	0030H to 0037H	Error history 5	0000H	R
56 to 63	0038H to 003FH	Error history 6	0000H	R
64 to 71	0040H to 0047H	Error history 7	0000H	R
72 to 79	0048H to 004FH	Error history 8	0000H	R
80 to 87	0050H to 0057H	Error history 9	0000H	R
88 to 95	0058H to 005FH	Error history 10	0000H	R
96 to 103	0060H to 0067H	Error history 11	0000H	R
104 to 111	0068H to 006FH	Error history 12	0000H	R
112 to 119	0070H to 0077H	Error history 13	0000H	R
120 to 127	0078H to 007FH	Error history 14	0000H	R
128 to 135	0080H to 0087H	Error history 15	0000H	R
136 to 143	0088H to 008FH	Error history 16	0000H	R
144 to 255	0090H to 00FFH	System area	—	—

*1 This column indicates whether reading or writing values using programs is possible.

R: Readable

W: Writable

Monitoring area

Address (decimal)	Address (hexadecimal)	Description	Module		Default value	Read/Write ^{*1}
			Safety input module	Safety output module		
256	0100H	Latest error code	○	○	0000H	R
257	0101H	Safety module validation status	○	○	0000H	R
258 to 767	0102H to 02FFH	System area	—	—	—	—
768	0300H	Double input discrepancy auto recovery enabled signal	○	—	0000H	R
769	0301H	Input state area	○	—	0000H	R
770 to 1279	0302H to 04FFH	System area	—	—	—	—
1280	0500H	Output state area	—	○	0000H	R
1281 to 1791	0501H to 06FFH	System area	—	—	—	—

*1 This column indicates whether reading or writing values using programs is possible.

R: Readable

W: Writable

Details of buffer memory addresses

This section describes the details on the buffer memory in the safety I/O module.

Latest address of error history

The following table shows the buffer memory addresses where the latest error history is stored.

■Address

Buffer memory name	Buffer memory address
Latest address of error history	Un\G0

Error history number

Up to 16 errors that occurred in the safety I/O module are recorded from the latest to the oldest. The error history area is common to the safety I/O module. For the error history function, refer to the following.

☞ Page 85 Error Information

■Address

Buffer memory name	Buffer memory address
Error history 1 to Error history 16	Un\G16 to Un\G143

Ex.

The following tables show the data structure and contents stored in 'Error history 1' (Un\G16 to Un\G23).

• Data structure

Address	b15 to b8	b7 to b0
Un\G16	Error code	
Un\G17	First two digits of the year (BCD code)	Last two digits of the year (BCD code)
Un\G18	Month (BCD code)	Day (BCD code)
Un\G19	Hour (BCD code)	Minute (BCD code)
Un\G20	Second (BCD code)	Day of the week (BCD code)
Un\G21	ms upper (BCD code)	ms lower (BCD code)
Un\G22	System area	
Un\G23	System area	

• Data contents

Item	Storage contents	Storage example*1
Error code	The error codes of the safety I/O module are stored.	—
First two digits of the year, Last two digits of the year	The items on the left are stored in BCD code.	2024H
Month, Day		0107H
Hour, Minute		1035H
Second		40H
Day of the week	One of the following values is stored in BCD code. <ul style="list-style-type: none"> • Sunday: 0 • Monday: 1 • Tuesday: 2 • Wednesday: 3 • Thursday: 4 • Friday: 5 • Saturday: 6 	00H
ms upper, ms lower	The items on the left are stored in BCD code.	0628H

*1 These are values when an error occurs on January 7 (Sunday), 2024, at 10:35:40:628ms.

Point

- 'Error history 2' (Un\G24 to Un\G31) to 'Error history 16' (Un\G136 to Un\G143) are stored in the same format as 'Error history 1' (Un\G16 to Un\G23).
- When the error history storage areas are full, the data is overwritten in order from 'Error history 1' (Un\G16 to Un\G23), and the error history recording continues. Existing data is deleted by overwriting.
- The recorded error history is cleared by powering off the safety I/O module or resetting the CPU module.

Latest error code

The latest error code detected in the safety I/O module is stored.

■Address

Buffer memory name	Buffer memory address
Latest error code	Un\G256

Safety module validation status

The safety module validation status is stored.

b15	b14	b13	b12	b11	b10	b9	b8	b7	b6	b5	b4	b3	b2	b1	b0
Fixed to 0														(1)	

(1) Safety module validation status

- 0000H: Invalid (default)
- 0001H: Valid (Reset Wait)
- 0002H: Valid

■Address

Buffer memory name	Buffer memory address
Safety module validation status	Un\G257

Double input discrepancy auto recovery enabled signal

This area stores the status of the double input discrepancy auto recovery enabled signal. It turns on when "Double input discrepancy auto recovery setting" in the application settings is set to "Used".

b15	b14	b13	b12	b11	b10	b9	b8	b7	b6	b5	b4	b3	b2	b1	b0
Fixed to 0														(1)	

(1) Double input discrepancy auto recovery enabled signal

- 0: Not used
- 1: Used

■Address

Buffer memory name	Buffer memory address
Double input discrepancy auto recovery enabled signal	Un\G768

Input state area

The input function status is stored. When a double input discrepancy detection error, input dark test error, or input internal dark test error occurs, the input state area of the input point where the error has occurred turns on.

b15	b14	b13	b12	b11	b10	b9	b8	b7	b6	b5	b4	b3	b2	b1	b0
XF	XE	XD	XC	XB	XA	X9	X8	X7	X6	X5	X4	X3	X2	X1	X0

- 0: Normal
- 1: Error

■Address

Buffer memory name	Buffer memory address
Input state area	Un\G769

Output state area

The output function status is stored. When an output read-back error or output dark test error occurs, the output state area of the output point where the error has occurred turns on.

b15	b14	b13	b12	b11	b10	b9	b8	b7	b6	b5	b4	b3	b2	b1	b0
Fixed to 0								Y7	Y6	Y5	Y4	Y3	Y2	Y1	Y0

- 0: Normal
- 1: Error

■Address

Buffer memory name	Buffer memory address
Output state area	Un\G1280

Appendix 4 Compliance with EMC and Low Voltage Directives

In each country, laws and regulations concerning electromagnetic compatibility (EMC) and electrical safety are enacted. For the products sold in the European countries, compliance with the EU's EMC Directive has been a legal obligation as EMC regulation since 1996, as well as the EU's Low Voltage Directive as electrical safety regulation since 1997.

Manufacturers who recognize their products are compliant with the EMC and Low Voltage Directives are required to attach a "CE marking" on their products in European countries.

In some other countries and regions, manufacturers are required to make their products compliant with applicable laws or regulations and attach a certification mark on the products as well (such as UK Conformity Assessed (UKCA) marking in the UK, and Korea Certification (KC) marking in South Korea).

Each country works to make their regulatory requirements consistent across countries based on international standards.

When the requirements are consistent, measures to comply with the EMC and electrical safety regulations become common across countries.

The UK and South Korea have enacted EMC regulations whose requirements are consistent with those of the EMC Directive.

The UK has also enacted electrical safety regulations whose requirements are consistent with those of the Low Voltage Directive. In this section, the requirements of the EMC and Low Voltage Directives are described as examples of those of the EMC and electrical safety regulations.

Measures to comply with the EMC Directive

The EMC Directive sets requirements for emission (conducted and radiated electromagnetic interference emitted by a product) and immunity (the ability of a product not to be influenced by externally generated electromagnetic interference).

This section describes the precautions for machinery constructed with the MELSEC iQ-R series modules to comply with the EMC Directive.

These precautions are based on the requirements of the EMC Directive and the harmonized standards. However, they do not guarantee that the entire machinery constructed according to the descriptions complies with the EMC Directive.

The manufacturer of the machinery must determine the testing method for compliance and declare conformity to the EMC Directive.

A

EMC Directive related standards

■Emission requirements

Standard: EN61131-2:2007

Test item	Test description	Value specified in standard
CISPR16-2-3 Radiated emission ^{*2}	The electromagnetic wave emitted by the product to the external space is measured.	<ul style="list-style-type: none"> • 30 to 230MHz, QP: 40dBμV/m (measured at 10m distance)^{*1} • 230 to 1000MHz, QP: 47dBμV/m (measured at 10m distance)
CISPR16-2-1, CISPR16-1-2 Conducted emission ^{*2}	The noise level which the product emits to the power line is measured.	<ul style="list-style-type: none"> • 0.15 to 0.5MHz, QP: 79dB, Mean: 66dB^{*1} • 0.5 to 30MHz, QP: 73dB, Mean: 60dB

*1 QP: Quasi-Peak value, Mean: Average value

*2 Programmable controller is an open-type device and must be placed in a conductive control panel or similar type of enclosure. The tests were conducted with the programmable controller installed in a control panel, applying the maximum rated input voltage of the power supply module.

■Immunity requirements

Standard: EN61131-2:2007

Test item	Test description	Value specified in standard
EN61000-4-2 Electrostatic discharge immunity ^{*1}	An electrostatic discharge is applied to the enclosure of the equipment.	<ul style="list-style-type: none"> • 8kV: Air discharge • 4kV: Contact discharge
EN61000-4-3 Radiated, radio-frequency, electromagnetic field immunity ^{*1}	An electric field is radiated to the product.	80% AM modulation @1kHz <ul style="list-style-type: none"> • 80 to 1000MHz: 10V/m • 1.4 to 2.0GHz: 3V/m • 2.0 to 2.7GHz: 1V/m
EN61000-4-4 Fast transient burst immunity ^{*1}	Burst noise is applied to power lines and signal lines.	<ul style="list-style-type: none"> • AC/DC power, I/O power, and AC I/O (unshielded) lines: 2kV • DC I/O, analog, and communication lines: 1kV
EN61000-4-5 Surge immunity ^{*1}	Lightning surge is applied to power lines and signal lines.	<ul style="list-style-type: none"> • AC power, AC I/O power, and AC I/O (unshielded) lines: 2kV CM, 1kV DM • DC power and DC I/O power lines: 0.5kV CM, 0.5kV DM • DC I/O, AC I/O (shielded), analog^{*2}, and communication lines: 1kV CM
EN61000-4-6 Conducted RF immunity ^{*1}	High-frequency noise is applied to power lines and signal lines.	0.15 to 80MHz, 80% AM modulation @1kHz, 10Vrms
EN61000-4-8 Power-frequency magnetic field immunity ^{*1}	The product is immersed in the magnetic field of an induction coil.	50/60Hz, 30A/m
EN61000-4-11 Voltage dips and interruptions immunity ^{*1}	Power voltage is momentarily interrupted.	<ul style="list-style-type: none"> • 0%, 0.5 periods, starting at zerocrossing • 0%, 250/300 periods (50/60Hz) • 40%, 10/12 periods (50/60Hz) • 70%, 25/30 periods (50/60Hz)

*1 Programmable controller is an open-type device and must be placed in a conductive control panel or similar type of enclosure. The tests were conducted with the programmable controller installed in a control panel.

*2 The accuracy of an analog-digital converter module may temporarily vary within $\pm 10\%$.

Installation in a control panel

Programmable controller is an open-type device intended to be placed in a conductive control panel or similar type of enclosure.

Remote modules on each network must be also installed inside the control panel. Waterproof type remote modules can be installed outside the control panel.

This ensures safety as well as effective shielding of electromagnetic noise emitted from the programmable controller.

■Control panel

- Use a conductive control panel.
- Mask off an area used for grounding when securing the top or bottom plate to the control panel using bolts.
- To ensure electrical contact between inner plates and the control panel, mask off the bolt installation areas of each inner plate so that conductivity can be ensured in the largest area.
- Ground the control panel with a thick ground cable so that low impedance can be ensured even at high frequencies.
- Keep the diameter of the holes on the control panel to 10cm or less. If the diameter is larger than 10cm, electromagnetic wave may leak. In addition, because electromagnetic wave leaks through a clearance between the control panel and its door, reduce the clearance as much as possible. Use of EMI gaskets (sealing the clearance) can suppress undesired radiated emissions.

The tests were conducted by Mitsubishi Electric Corporation using a control panel having damping characteristics of 37dB (maximum) and 30dB (average) (measured at 3m distance, 30 to 300MHz).

■Power cable and ground cable

- Provide a ground point to the control panel near the power supply module. Ground the LG and FG terminals of the power supply module to the ground point with the shortest and thickest ground cable possible (30cm or shorter, 2mm²).
- Twist the ground cable extended from the ground point with the power cable so that larger amount of noise generated from the power cable is absorbed to the ground. Note that if a noise filter is attached to the power cable, twisting may not be required.

■DIN rails

Aluminum DIN rails may have insulation films. If an electrical contact cannot be secured between a DIN rail and a programmable controller, take measures to obtain conductivity. The following methods can be used to obtain conductivity.

- Screw the programmable controller to the control panel directly, without using a DIN rail.
- Use iron DIN rails, such as TH35-7.5Fe and TH35-15Fe.

■Extension cables

- Wire cables with extension cables placed in ducts. If not, dangling cable may swing or inadvertently be pulled, resulting in damage to the module or cables or malfunction due to poor contact.
- Do not clamp the extension cables with the jacket stripped.
- Use the shortest extension cable according to the distance between the base units connected.

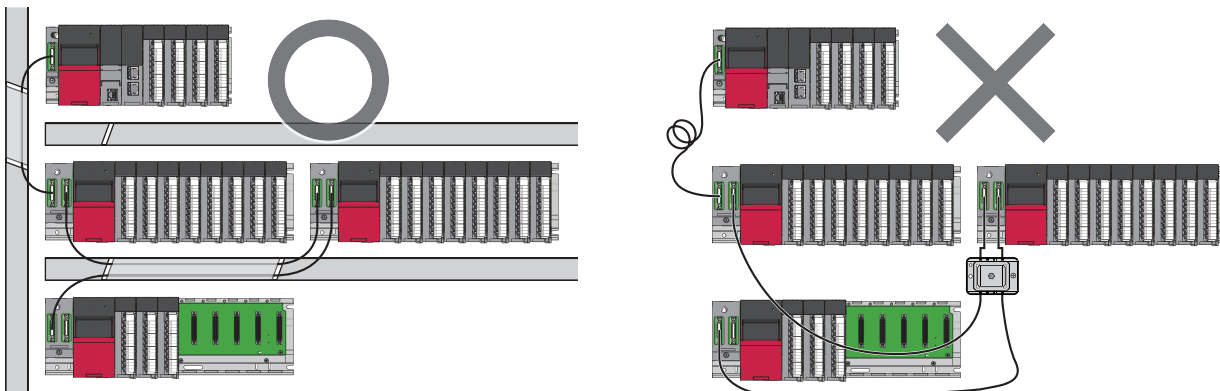

■ Noise filter (power supply line filter)

A noise filter is effective for reducing conducted noise in the 10MHz or less frequency band. (Use of a noise filter can suppress noise.)

The following are the installation precautions.

- Do not bundle the cables on the input side and output side of the noise filter. If bundled, the noise on the output side is induced into the filtered cable on the input side.

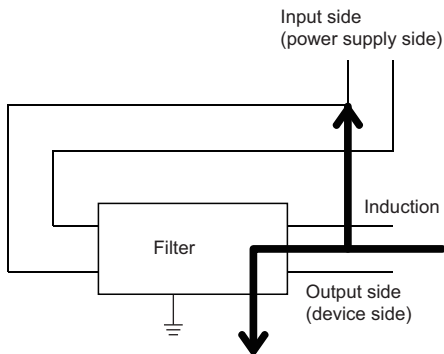

- Wrong example
Noise is induced when the input and output cables are bundled.

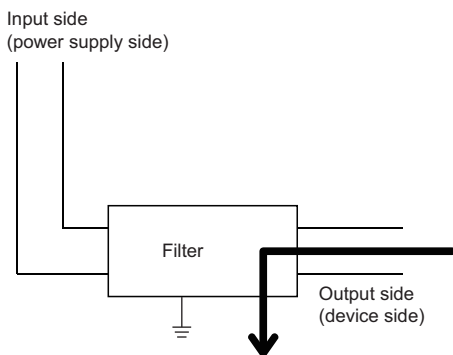

- Correct example
Install the input and output cables separately.

- Ground the ground terminal of the noise filter to the ground point of the control panel with the shortest cable possible (approximately 10cm).

■ Isolation transformer

An Isolation transformer is effective for reducing conducted noise (especially, lightning surge). Lightning surge may cause malfunction of the programmable controller. As measures against lightning surge, connect an isolation transformer as shown below. Use of an isolation transformer can reduce a lightning effect.

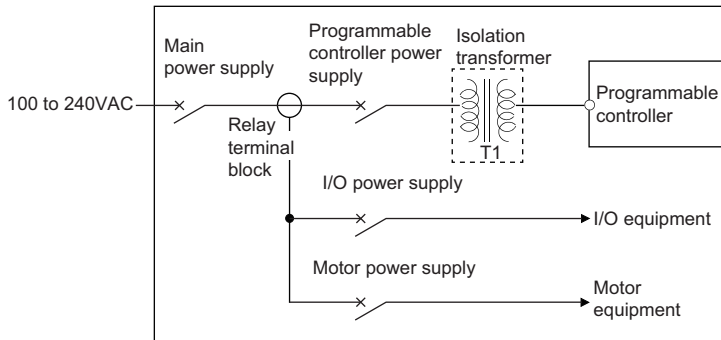

Use the isolation transformer according to its usage environment and storage environment. The following table lists the performance specifications of the recommended isolation transformer.

Item	Specifications
Number of phase	Single phase
Frequency	50/60Hz
Rated capacity	*1
Secondary voltage*2	200V/100V
Rating	Continuous
Heat resistance class (insulation class)	H
Electrostatic shield	Provided
Isolation resistance and withstand voltage*3	4200V/1 minute, 5MΩ or more between P and S
	2500V/1 minute, 7MΩ or more between P and iron core
	2500V/1 minute, 7MΩ or more between S and iron core
Standard*4	UL 506, UL 5085
	EN 61558-1
	EN 61558-2-4

*1 Select an isolation transformer considering the power capacity of equipment to be used.

*2 Select the secondary voltage so that the input voltage specifications of the power supply module are met.

*3 Among required voltage values specified in UL and EN standards, stricter values are listed here.

*4 Use an isolation transformer in the conditions that satisfy the requirements of standards.

Cables extended out of the control panel

Use a shielded cable for a cable extended out of the control panel such as an I/O signal line (including a common line) and cable for communications.

If a shielded cable is not used or not grounded properly, the noise immunity will not meet the requirement.

■Grounding a shielded cable

- Ground the shield of a shielded cable as close to the module as possible so that the grounded cable will not be affected by electromagnetic induction from ungrounded cables.
- Ground the exposed shield to a large area on the control panel. A clamp can be used as shown below. In this case, mask off the inner wall surface of the control panel, which comes in contact with the clamp.



Point

Do not use the tip of a PVC wire soldered onto a shield of the shielded cable for grounding. Doing so will raise the high-frequency impedance, resulting in loss of the shielding effect.

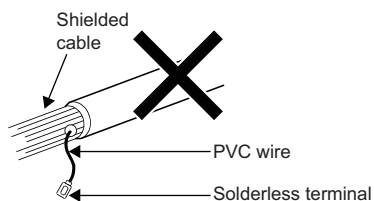

■Grounding cables with a cable clamp

Use shielded cables for external wiring and ground the shields of the shielded cables to the control panel with an AD75CK cable clamp (manufactured by Mitsubishi Electric). Ground the shields within 20 to 30cm from the module.

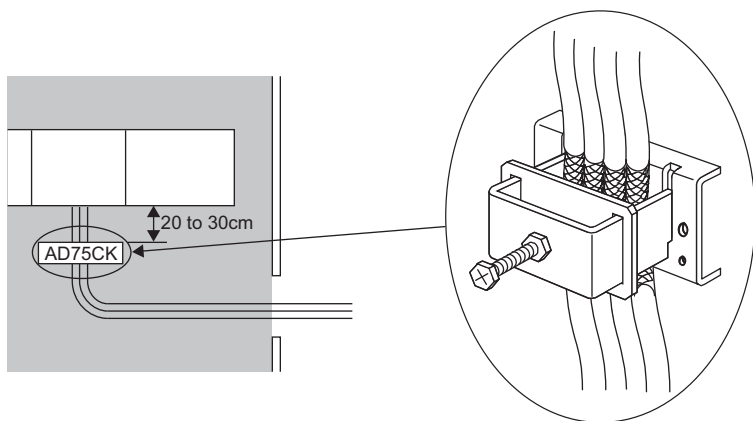

For details on the AD75CK, refer to the following.

📖 AD75CK-type Cable Clamping Instruction Manual

■ Ferrite core

A ferrite core is effective for reducing radiated noise in the 30MHz to 100MHz frequency band.

It is recommended to install a ferrite core if a shield cable extended out of the control panel does not provide sufficient shielding effects.

Install a ferrite core to the cable in the position just before the cable is extended out of the control panel. If the installation position is not appropriate, the ferrite core will not produce any effect.

Install a ferrite core to each power cable as shown below.

- Ferrite core used for the tests conducted by Mitsubishi Electric: ESD-SR-250 (manufactured by TOKIN Corporation), ZCAT3035-1330 (manufactured by TDK Corporation)

Ex.

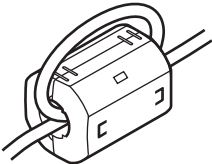

Connectors for external devices

When a module that requires a connector for external devices is used, take the following noise reduction measures.

- When shielded cables are connected

The following figure shows an example of wiring against noise when a connector (A6CON1) is used.

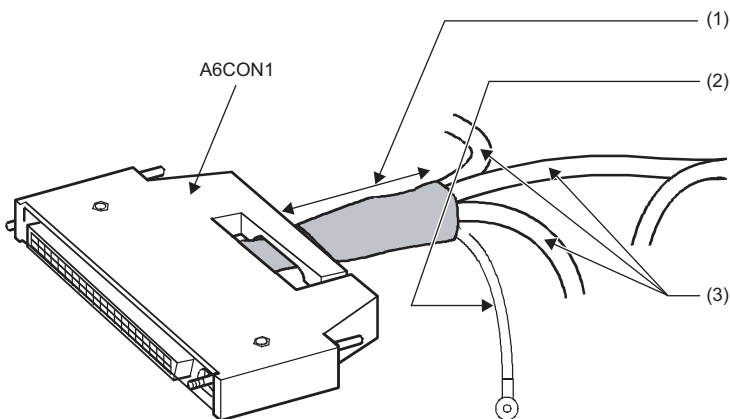

- (1) The length between the connector and the shielded cables should be the shortest possible.
- (2) Ground the FG wire of 2mm² or more as short as possible. Ground it to the control panel on the module side.
- (3) Shielded cable

- When shielded cables are processed

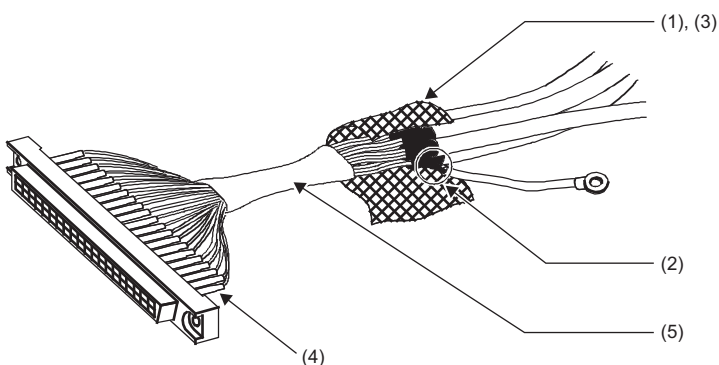

- (1) Strip the jacket of each shield of the cables.
- (2) Solder the shield of any shielded cable to the FG wire.
- (3) Bundle the shields with conductive tape.
- (4) To protect the wires, cover the connector pins with heat shrinkable insulating tubes. Exposed wires may cause malfunction of the module due to static electricity.
- (5) Cover the conductive part with insulating tape.

A

• When a duct is used (wrong example and correct example)

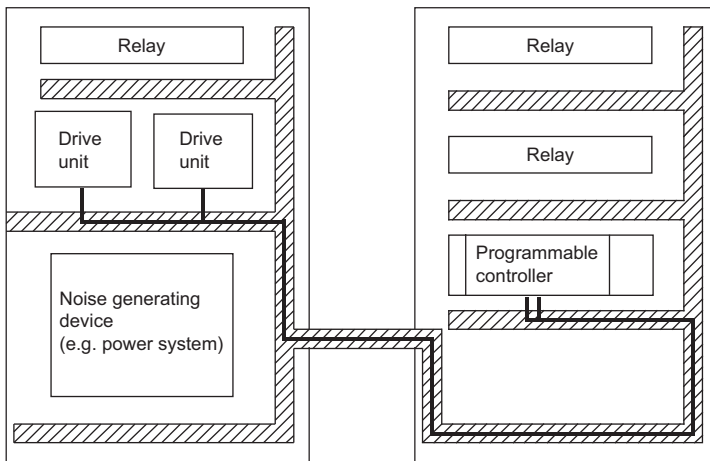

• Wrong example

The drive units are placed near the noise source. The connection cables between the programmable controller and drive units are too long.

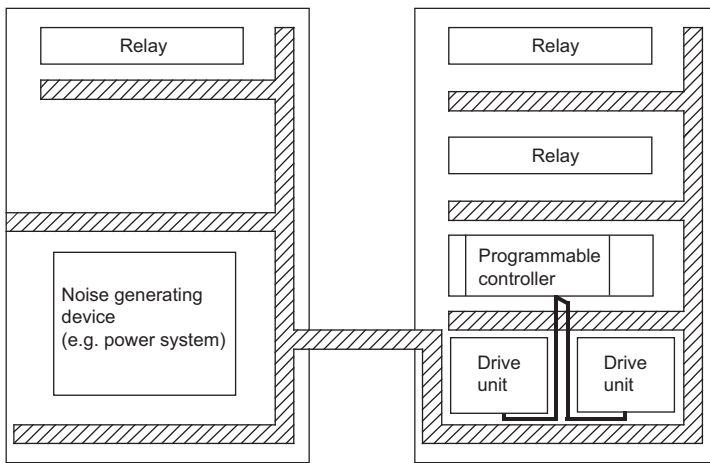

• Correct example

The programmable controller and drive units are placed closely. The connected cables between them are placed separately from the power line and the shortest. (In this example, the cables are connected without using the duct.)

Shaded part: Wiring duct

External power supply

Use a reinforced or double insulated CE-marked external power supply, and ground the FG terminal.

- External power supply used for the tests conducted by Mitsubishi Electric: PS6R-F24 (manufactured by IDEC Corporation)

Measures to comply with the Low Voltage Directive

External wiring

■24VDC external power supply

For 24VDC I/O modules or intelligent function modules requiring an external power supply, connect an external power supply of which insulation between the 24VDC circuit section and the hazardous voltage circuit section is reinforced.

■External devices

For external devices connected to a programmable controller, use the one of which insulation between the interface circuit section to the programmable controller and the hazardous voltage circuit section is reinforced (if the device internally has a hazardous voltage circuit section).

■Reinforced insulation

Reinforced insulation means insulation having the following withstand voltage.

Rated voltage of hazardous voltage	Surge withstand voltage (1.2/50 μ s)
150VAC or less	2500V
300VAC or less	4000V

(Overvoltage category II, source: IEC 60664-1)

Appendix 5 Checking Production Information and Firmware Version

Checking methods

This section describes how to check the production information and firmware version of the safety I/O module.

Checking with the safety I/O module

■Rating plate

The rating plate is located on the side of the module.

The production information (16 digits) of the module is shown on the SERIAL field. The first two digits of the production information indicate the firmware version.

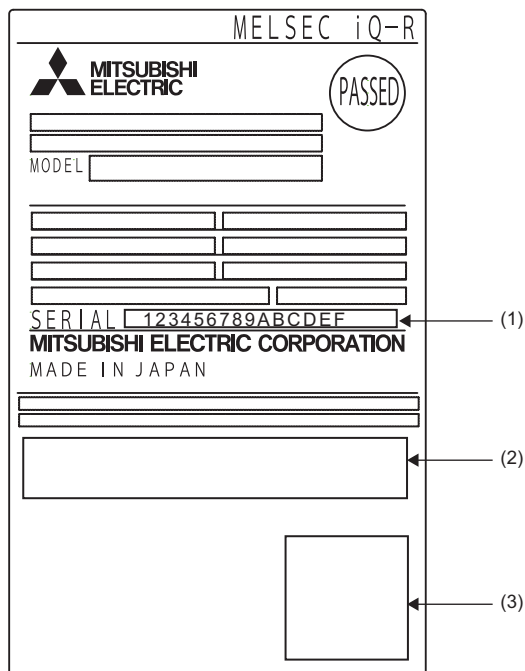

- (1) Production information (16 digits)
- (2) Relevant regulation standards
- (3) QR code

■Production information marking

The production information (16 digits) of the module is printed on the marking on the front (at the bottom) of the module.

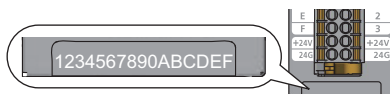

Checking with the engineering tool

■Product information list

The firmware version and the production information (16 digits) of the module can be checked on the "Product Information List" window.

☞ [Diagnostics] ⇒ [System Monitor] ⇒ [Product Information List] button

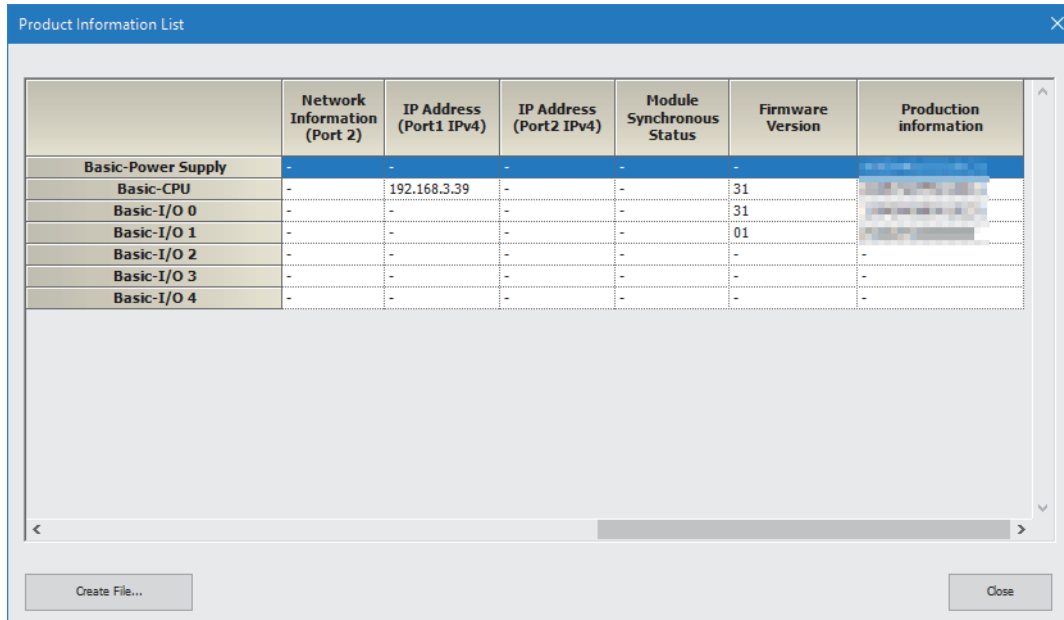

The screenshot shows the "Product Information List" window with a table containing the following data:

	Network Information (Port 2)	IP Address (Port1 IPv4)	IP Address (Port2 IPv4)	Module Synchronous Status	Firmware Version	Production information
Basic-Power Supply	-	-	-	-	-	-
Basic-CPU	-	192.168.3.39	-	-	31	-
Basic-I/O 0	-	-	-	-	31	-
Basic-I/O 1	-	-	-	-	01	-
Basic-I/O 2	-	-	-	-	-	-
Basic-I/O 3	-	-	-	-	-	-
Basic-I/O 4	-	-	-	-	-	-

■Module diagnostics

The production information (16 digits) of the module can be checked on the "Module Diagnostics" window.

☞ [Diagnostics] ⇒ [System Monitor] ⇒ Right-click the module to be checked ⇒ "Module Diagnostics"

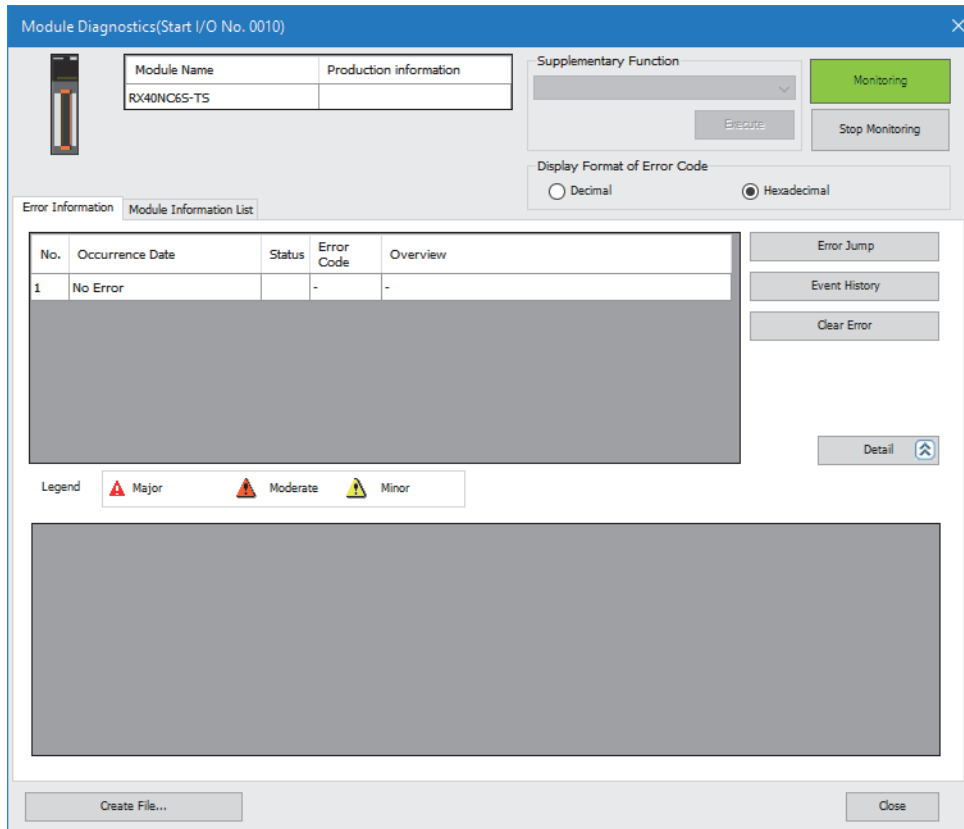

The screenshot shows the "Module Diagnostics(Start I/O No. 0010)" window. It includes a "Module Name" field with "RX40NC6S-T5" and a "Production information" field. There are buttons for "Monitoring", "Stop Monitoring", "Error Jump", "Event History", "Clear Error", and "Detail". A legend at the bottom indicates error levels: Major (red triangle), Moderate (orange triangle), and Minor (yellow triangle).

No.	Occurrence Date	Status	Error Code	Overview
1	No Error		-	-



Appendix 6 External Dimensions

Safety I/O module

■RX40NC6S-TS, RY48PT20S-TS

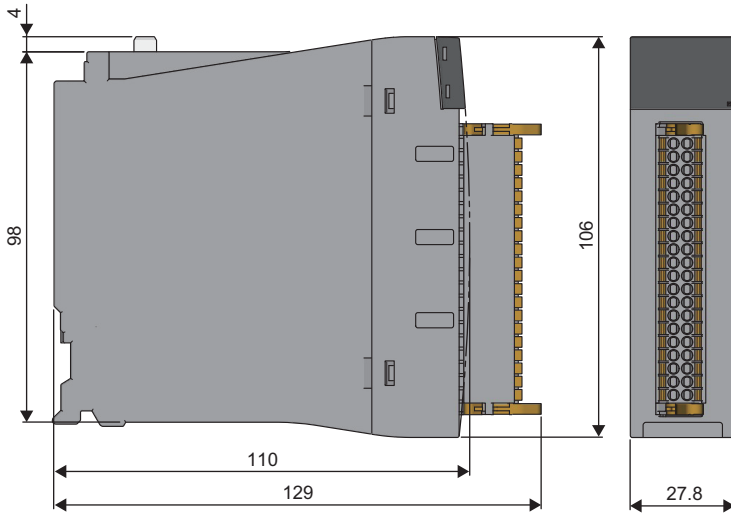

(Unit: mm)

INDEX

C

Checking the safety module position 50

D

Double input discrepancy auto recovery enabled signal (UnG768) 109
Double input discrepancy state X0 X1 to XE XF (SAX10 to SAX17) 102

E

EMC Directive 111
ERR LED 14
Error history 1 to 16 (UnG16 to UnG143) 108
Error history area (UnG0 to UnG255) 105
External input monitor signal 99
External power supply overvoltage protection 73
External power supply status (SAX1D) 102

F

Ferrite core 117

I

I/O LED indication setting function on error condition 80
I/O status indicator LED 14
I/O terminal block 14
Input state area (UnG769) 109

L

Latest address of error history (UnG0) 107
Latest error code (UnG256) 109
List of error codes 94
Low Voltage Directive 119

M

Major error 93
Minor error 93
Moderate error 93
Module power supply overcurrent protection 73
Module power supply overvoltage protection 73
Module READY 99
Monitoring area (UnG256 to UnG1791) 106

N

Noise filter 114

O

Operation mode and state transition 26
Output state area (UnG1280) 110

R

RUN LED 14
RX40NC6S-TS DC input module 17
RY48PT20S-TS transistor output module 20

S

Safety control initial processing completion flag (SAX1F) 103
Safety control initial processing request flag (SAY1E) 103
Safety control READY (SAX0, SAX1E) 103
Safety control start flag (SAY1F) 103
Safety input signals X0 to XF 102
SAFETY LED 14
Safety module validation status (UnG257) 109
Safety output signals Y0 to Y7 (SAY0 to SAY7) . . . 104
Safety response time 23

MEMO

REVISIONS

*The manual number is given on the bottom left of the back cover.

Revision date	*Manual number	Description
January 2024	SH(NA)-082639ENG-A	First edition

Japanese manual number: SH-082638-A

This manual confers no industrial property rights or any rights of any other kind, nor does it confer any patent licenses. Mitsubishi Electric Corporation cannot be held responsible for any problems involving industrial property rights which may occur as a result of using the contents noted in this manual.

© 2024 MITSUBISHI ELECTRIC CORPORATION

WARRANTY

Please confirm the following product warranty details before using this product.

1. Limited Warranty and Product Support.

- a. Mitsubishi Electric Company ("MELCO") warrants that for a period of eighteen (18) months after date of delivery from the point of manufacture or one year from date of Customer's purchase, whichever is less, Mitsubishi MELSEC Safety programmable logic controllers (the "Products") will be free from defects in material and workmanship.
- b. At MELCO's option, for those Products MELCO determines are not as warranted, MELCO shall either repair or replace them or issue a credit or return the purchase price paid for them.
- c. For this warranty to apply:
 - (1) Customer shall give MELCO (i) notice of a warranty claim to MELCO and the authorized dealer or distributor from whom the Products were purchased, (ii) the notice shall describe in reasonable details the warranty problem, (iii) the notice shall be provided promptly and in no event later than thirty (30) days after the Customer knows or has reason to believe that Products are not as warranted, and (iv) in any event, the notice must be given within the warranty period;
 - (2) Customer shall cooperate with MELCO and MELCO's representatives in MELCO's investigation of the warranty claim, including preserving evidence of the claim and its causes, meaningfully responding to MELCO's questions and investigation of the problem, grant MELCO access to witnesses, personnel, documents, physical evidence and records concerning the warranty problem, and allow MELCO to examine and test the Products in question onsite or at the premises where they are installed or used; and
 - (3) If MELCO requests, Customer shall remove Products it claims are defective and ship them to MELCO or MELCO's authorized representative for examination and, if found defective, for repair or replacement. The costs of removal, shipment to and from MELCO's designated examination point, and reinstallation of repaired or replaced Products shall be at Customer's expense.
 - (4) If Customer requests and MELCO agrees to effect repairs onsite at any domestic or overseas location, the Customer will pay for the costs of sending repair personnel and shipping parts. MELCO is not responsible for any re-commissioning, maintenance, or testing on-site that involves repairs or replacing of the Products.
- d. Repairs of Products located outside of Japan are accepted by MELCO's local authorized service facility centers ("FA Centers"). Terms and conditions on which each FA Center offers repair services for Products that are out of warranty or not covered by MELCO's limited warranty may vary.
- e. Subject to availability of spare parts, MELCO will offer Product repair services for (7) years after each Product model or line is discontinued, at MELCO's or its FA Centers' rates and charges and standard terms in effect at the time of repair. MELCO usually produces and retains sufficient spare parts for repairs of its Products for a period of seven (7) years after production is discontinued.
- f. MELCO generally announces discontinuation of Products through MELCO's Technical Bulletins. Products discontinued and repair parts for them may not be available after their production is discontinued.

2. Limits of Warranties.

- a. MELCO does not warrant or guarantee the design, specify, manufacture, construction or installation of the materials, construction criteria, functionality, use, properties or other characteristics of the equipment, systems, or production lines into which the Products may be incorporated, including any safety, fail-safe and shut down systems using the Products.
- b. MELCO is not responsible for determining the suitability of the Products for their intended purpose and use, including determining if the Products provide appropriate safety margins and redundancies for the applications, equipment or systems into which they are incorporated.
- c. Customer acknowledges that qualified and experienced personnel are required to determine the suitability, application, design, construction and proper installation and integration of the Products. MELCO does not supply such personnel.
- d. MELCO is not responsible for designing and conducting tests to determine that the Product functions appropriately and meets application standards and requirements as installed or incorporated into the end-user's equipment, production lines or systems.
- e. MELCO does not warrant any Product:
 - (1) repaired or altered by persons other than MELCO or its authorized engineers or FA Centers;
 - (2) subjected to negligence, carelessness, accident, misuse, or damage;
 - (3) improperly stored, handled, installed or maintained;
 - (4) integrated or used in connection with improperly designed, incompatible or defective hardware or software;
 - (5) that fails because consumable parts such as batteries, backlights, or fuses were not tested, serviced or replaced;
 - (6) operated or used with equipment, production lines or systems that do not meet applicable and commensurate legal, safety and industry-accepted standards;
 - (7) operated or used in abnormal applications;
 - (8) installed, operated or used in contravention of instructions, precautions or warnings contained in MELCO's user, instruction and/or safety manuals, technical bulletins and guidelines for the Products;
 - (9) used with obsolete technologies or technologies not fully tested and widely accepted and in use at the time of the Product's manufacture;
 - (10) subjected to excessive heat or moisture, abnormal voltages, shock, excessive vibration, physical damage or other improper environment; or
 - (11) damaged or malfunctioning due to Acts of God, fires, acts of vandals, criminals or terrorists, communication or power failures, or any other cause or failure that results from circumstances beyond MELCO's control.
- f. All Product information and specifications contained on MELCO's website and in catalogs, manuals, or technical information materials provided by MELCO are subject to change without prior notice.

- g. The Product information and statements contained on MELCO's website and in catalogs, manuals, technical bulletins or other materials provided by MELCO are provided as a guide for Customer's use. They do not constitute warranties and are not incorporated in the contract of sale for the Products.
- h. These terms and conditions constitute the entire agreement between Customer and MELCO with respect to warranties, remedies and damages and supersede any other understandings, whether written or oral, between the parties. Customer expressly acknowledges that any representations or statements made by MELCO or others concerning the Products outside these terms are not part of the basis of the bargain between the parties and are not factored into the pricing of the Products.
- i. THE WARRANTIES AND REMEDIES SET FORTH IN THESE TERMS ARE THE EXCLUSIVE AND ONLY WARRANTIES AND REMEDIES THAT APPLY TO THE PRODUCTS.
- j. MELCO DISCLAIMS THE IMPLIED WARRANTIES OF MERCHANTABILITY AND FITNESS FOR A PARTICULAR PURPOSE.

3. Limits on Damages.

- a. MELCO'S MAXIMUM CUMULATIVE LIABILITY BASED ON ANY CLAIMS FOR BREACH OF WARRANTY OR CONTRACT, NEGLIGENCE, STRICT TORT LIABILITY OR OTHER THEORIES OF RECOVERY REGARDING THE SALE, REPAIR, REPLACEMENT, DELIVERY, PERFORMANCE, CONDITION, SUITABILITY, COMPLIANCE, OR OTHER ASPECTS OF THE PRODUCTS OR THEIR SALE, INSTALLATION OR USE SHALL BE LIMITED TO THE PRICE PAID FOR PRODUCTS NOT AS WARRANTED.
- b. Although MELCO has obtained the certification for Product's compliance to the international safety standards IEC61508 and ISO13849-1 from TUV Rheinland, this fact does not guarantee that Product will be free from any malfunction or failure. The user of this Product shall comply with any and all applicable safety standard, regulation or law and take appropriate safety measures for the system in which the Product is installed or used and shall take the second or third safety measures other than the Product. MELCO is not liable for damages that could have been prevented by compliance with any applicable safety standard, regulation or law.
- c. MELCO prohibits the use of Products with or in any application involving power plants, trains, railway systems, airplanes, airline operations, other transportation systems, amusement equipments, hospitals, medical care, dialysis and life support facilities or equipment, incineration and fuel devices, handling of nuclear or hazardous materials or chemicals, mining and drilling, and other applications where the level of risk to human life, health or property are elevated.
- d. MELCO SHALL NOT BE LIABLE FOR SPECIAL, INCIDENTAL, CONSEQUENTIAL, INDIRECT OR PUNITIVE DAMAGES, FOR LOSS OF PROFITS, SALES, OR REVENUE, FOR INCREASED LABOR OR OVERHEAD COSTS, FOR DOWNTIME OR LOSS OF PRODUCTION, FOR COST OVERRUNS, OR FOR ENVIRONMENTAL OR POLLUTION DAMAGES OR CLEAN-UP COSTS, WHETHER THE LOSS IS BASED ON CLAIMS FOR BREACH OF CONTRACT OR WARRANTY, VIOLATION OF STATUTE, NEGLIGENCE OR OTHER TORT, STRICT LIABILITY OR OTHERWISE.
- e. In the event that any damages which are asserted against MELCO arising out of or relating to the Products or defects in them, consist of personal injury, wrongful death and/or physical property damages as well as damages of a pecuniary nature, the disclaimers and limitations contained in these terms shall apply to all three types of damages to the fullest extent permitted by law. If, however, the personal injury, wrongful death and/or physical property damages cannot be disclaimed or limited by law or public policy to the extent provided by these terms, then in any such event the disclaimer of and limitations on pecuniary or economic consequential and incidental damages shall nevertheless be enforceable to the fullest extent allowed by law.
- f. In no event shall any cause of action arising out of breach of warranty or otherwise concerning the Products be brought by Customer more than one year after the cause of action accrues.
- g. Each of the limitations on remedies and damages set forth in these terms is separate and independently enforceable, notwithstanding the unenforceability or failure of essential purpose of any warranty, undertaking, damage limitation, other provision of these terms or other terms comprising the contract of sale between Customer and MELCO.

4. Delivery/Force Majeure.

- a. Any delivery date for the Products acknowledged by MELCO is an estimated and not a promised date. MELCO will make all reasonable efforts to meet the delivery schedule set forth in Customer's order or the purchase contract but shall not be liable for failure to do so.
- b. Products stored at the request of Customer or because Customer refuses or delays shipment shall be at the risk and expense of Customer.
- c. MELCO shall not be liable for any damage to or loss of the Products or any delay in or failure to deliver, service, repair or replace the Products arising from shortage of raw materials, failure of suppliers to make timely delivery, labor difficulties of any kind, earthquake, fire, windstorm, flood, theft, criminal or terrorist acts, war, embargoes, governmental acts or rulings, loss or damage or delays in carriage, acts of God, vandals or any other circumstances reasonably beyond MELCO's control.

5. Choice of Law/Jurisdiction.

These terms and any agreement or contract between Customer and MELCO shall be governed by the laws of the State of New York without regard to conflicts of laws. To the extent any action or dispute is not arbitrated, the parties consent to the exclusive jurisdiction and venue of the federal and state courts located in the Southern District of the State of New York. Any judgment there obtained may be enforced in any court of competent jurisdiction.

6. Arbitration.

Any controversy or claim arising out of, or relating to or in connection with the Products, their sale or use or these terms, shall be settled by arbitration conducted in accordance with the Center for Public Resources (CPR) Rules for Non-Administered Arbitration of International Disputes, by a sole arbitrator chosen from the CPR's panels of distinguished neutrals. Judgment upon the award rendered by the Arbitrator shall be final and binding and may be entered by any court having jurisdiction thereof. The place of the arbitration shall be New York City, New York. The language of the arbitration shall be English. The neutral organization designated to perform the functions specified in Rule 6 and Rules 7.7(b), 7.8 and 7.9 shall be the CPR.

TRADEMARKS

The company names, system names and product names mentioned in this manual are either registered trademarks or trademarks of their respective companies.

In some cases, trademark symbols such as [™] or [®] are not specified in this manual.

SH(NA)-082639ENG-A(2401)MEE

MODEL: R-SFIO-U-E

MODEL CODE: 13JX9E

MITSUBISHI ELECTRIC CORPORATION

HEAD OFFICE: TOKYO BLDG., 2-7-3, MARUNOUCHI, CHIYODA-KU, TOKYO 100-8310, JAPAN
NAGOYA WORKS: 1-14, YADA-MINAMI 5-CHOME, HIGASHI-KU, NAGOYA 461-8670, JAPAN

When exported from Japan, this manual does not require application to the
Ministry of Economy, Trade and Industry for service transaction permission.

Specifications subject to change without notice.