

Programmable Controller

**MELSEC iQ-F**  
series

MELSEC iQ-F FX5  
Motion Module/  
Simple Motion Module  
User's Manual (Startup)

---

-FX5-40SSC-G  
-FX5-80SSC-G  
-FX5-40SSC-S  
-FX5-80SSC-S





# WHEN USING AN INDUSTRIAL SWITCH WITH CC-Link IE TSN

---

To connect modules on CC-Link IE TSN, a dedicated industrial switch (for CC-Link IE TSN Class B) may be required depending on parameter settings or the network topology used.

Read the following carefully.

 Page 68 Industrial switch

 MELSEC iQ-F FX5 Motion Module User's Manual (CC-Link IE TSN)



## SAFETY PRECAUTIONS

---

(Read the precautions before using this product.)

Before using this product, please read this manual and the relevant manuals carefully and pay full attention to safety to handle the product correctly.

If the equipment is used in a manner not specified by the manufacturer, the protection provided by the equipment may be impaired.

This manual classifies the safety precautions into two categories: [ WARNING] and [ CAUTION].

---

 <b>WARNING</b>	Indicates that incorrect handling may cause hazardous conditions, resulting in death or severe injury.
 <b>CAUTION</b>	Indicates that incorrect handling may cause hazardous conditions, resulting in minor or moderate injury or property damage.

---

Depending on the circumstances, failure to observe procedures indicated by [ CAUTION] may also cause severe injury.

Observe the precautions of both levels because they are important for personal and system safety.

Ensure that the end users read this manual and then keep the manual in a safe place for future reference.

## [Design Precautions]

---

### **WARNING**

- Make sure to set up the following safety circuits outside the programmable controller to ensure safe system operation even during external power supply problems or programmable controller failure. Otherwise, malfunctions may cause serious accidents.
    - Emergency stop circuits, protection circuits, and protective interlock circuits (for conflicting operations such as forward/reverse rotations or for preventing damage to the equipment such as upper/lower limit positioning) must be configured external to the programmable controller.
    - Note that when the CPU module detects an error, such as a watchdog timer error, during self-diagnosis, all outputs are turned off. Also, when an error occurs in an input/output control block, where it cannot be detected by the CPU module, output control may be disabled. External circuits and mechanisms should be designed to ensure safe machinery operation in such a case.
    - Note that the output current of the 24 V DC service power supply varies depending on the model and the absence/presence of extension modules. If an overload occurs, the voltage automatically drops, inputs in the programmable controller are disabled, and all outputs are turned off. External circuits and mechanisms should be designed to ensure safe machinery operation in such a case.
    - Note that when an error occurs in a relay, triac or transistor of an output circuit, the output might stay on or off. For output signals that may lead to serious accidents, external circuits and mechanisms should be designed to ensure safe machinery operation in such a case.
  - Construct an interlock circuit in the program so that the whole system always operates on the safe side before executing the control (for data change) of the programmable controller in operation. Read the manual thoroughly and ensure complete safety before executing other controls (program change, parameter change, forced output, and operation status change) to the programmable controller in operation.

Improper operation may damage machines or cause accidents.
  - In an output circuit, when a load current exceeding the current rating or an overcurrent caused by a load short-circuit flows for a long time, it may cause smoke and fire. To prevent this, configure an external safety circuit, such as a fuse.
  - For the operating status of each station after a communication failure of the network, refer to relevant manuals for the network. Incorrect output or malfunction may result in an accident.
  - Especially, in the case of a control from an external device to a remote programmable controller, immediate action cannot be taken for a problem on the programmable controller due to a communication failure. Determine the handling method as a system when communication failure occurs along with configuration of interlock circuit on a program, by considering the external equipment and CPU module.
  - Do not write any data to the "manufacturer setting area", "system area", and "write-protect area" of the buffer memory in the module. Executing data writing to the "manufacturer setting area", "system area", or "write protect area" may cause malfunction of the programmable controller alarm. For the "manufacturer setting area", "system area", or "write-protect area", refer to "List of Buffer Memory Addresses" in MELSEC iQ-F FX5 Motion Module/Simple Motion Module User's Manual (Application) and "Buffer Memory" in MELSEC iQ-F FX5 Motion Module User's Manual (CC-Link IE TSN).
  - If a communication cable is disconnected, the network may be unstable, resulting in a communication failure of multiple stations. Construct an interlock circuit in the program so that the system always operates on the safe side even if communications fail. Incorrect output or malfunction may result in an accident.
-

---

## **WARNING**

- For the operating status of each station after a communication failure, refer to manuals for the network used. For the manuals, please consult your local Mitsubishi representative. Incorrect output or malfunction may result in an accident.

### [Precautions for using products in a UL/cUL Class I, Division 2 environment]

- Products<sup>\*1</sup> with the Cl.I, DIV.2 mark on the rating plate are suitable for use in Class I, Division 2, Groups A, B, C and D hazardous locations, or nonhazardous locations only.

This mark indicates that the product is certified for use in the Class I, Division 2 environment where flammable gases, vapors, or liquids exist under abnormal conditions.

When using the products in the Class I, Division 2 environment, observe the following conditions to reduce the risk of explosion.

- This device is open-type and is to be installed in an enclosed area under suitable environment which requires a tool or key to open.
- Warning - Explosion Hazard - Substitution of any component may impair suitability for Class I, Division 2.
- Warning - Explosion Hazard - Do not disconnect equipment while the circuit is live or unless the area is known to be free of ignitable concentrations.
- Only while the power is off or in nonhazardous locations, switch or press buttons.
- Do not open the cover of the CPU module and remove the battery unless the area is known to be nonhazardous.
- Ambient temperature: 0 to 55°C  
Temperature class: T4A

---

\*1 The supported products are as follows:

Manufactured in October 2017 onwards

· FX5 CPU module

FX5UC-32MT/D, FX5UC-32MT/DSS, FX5UC-64MT/D, FX5UC-64MT/DSS, FX5UC-96MT/D, FX5UC-96MT/DSS

· FX5 extension module

FX5-C16EX/D, FX5-C16EX/DS, FX5-C16EYT/D, FX5-C16EYT/DSS, FX5-C32EX/D, FX5-C32EX/DS, FX5-C32EYT/D, FX5-C32EYT/DSS, FX5-C32ET/D, FX5-C32ET/DSS, FX5-232ADP, FX5-485ADP, FX5-C1PS-5V, FX5-CNV-BUSC, FX5-4AD-ADP, FX5-4DA-ADP

## [Design Precautions]

---

### CAUTION

- When an inductive load such as a lamp, heater, or solenoid valve is controlled, a large current (approximately ten times greater than normal) may flow when the output is turned from off to on. Take proper measures so that the flowing current does not exceed the value corresponding to the maximum load specification of the resistance load.
  - After the CPU module is powered on or is reset, the time taken to enter the RUN status varies depending on the system configuration, parameter settings, and/or program size.  
Design circuits so that the entire system will always operate safely, regardless of this variation in time.
  - Simultaneously turn on and off the power supplies of the CPU module and extension modules.
  - If a long-time power failure or an abnormal voltage drop occurs, the programmable controller stops, and output is turned off. When the power supply is restored, it will automatically restart (when the RUN/STOP/RESET switch is on RUN side).
  - Do not bundle the control line and communication cables together with or lay them close to the main circuit or power line. Keep a distance of 100 mm or more between them. Failure to do so may result in malfunction due to noise.
- 

## [Security Precautions]

---

### WARNING

- To maintain the security (confidentiality, integrity, and availability) of the programmable controller and the system against unauthorized access, denial-of-service (DoS) attacks, computer viruses, and other cyberattacks from external devices via the network, take appropriate measures such as firewalls, virtual private networks (VPNs), and antivirus solutions.
- 

## [Installation Precautions]

---

### WARNING

- Make sure to cut off all phases of the power supply externally before attempting installation or wiring work. Failure to do so may cause electric shock or damage to the product.
  - Use the product within the generic environment specifications described in the generic specifications of the user's manual (Hardware) of the CPU module used.  
Never use the product in areas with excessive dust, oily smoke, conductive dust, corrosive gas (salt air, Cl<sub>2</sub>, H<sub>2</sub>S, SO<sub>2</sub>, or NO<sub>2</sub>), flammable gas, or vibration or impacts, or expose it to high temperature, condensation, or rain and wind.  
If the product is used in such conditions, electric shock, fire, malfunctions, deterioration or damage may occur.
-

## [Installation Precautions]

---

### **CAUTION**

- Do not touch the conductive parts of the product directly. Doing so may cause device failures or malfunctions.
  - When drilling screw holes or wiring, make sure that cutting and wiring debris do not enter the ventilation slits of the programmable controller. Failure to do so may cause fire, equipment failures or malfunctions.
  - For products supplied together with a dust proof sheet, the sheet should be affixed to the ventilation slits before the installation and wiring work to prevent foreign objects such as chips and wiring debris. However, when the installation work is completed, make sure to remove the sheet to provide adequate ventilation. Failure to do so may cause fire, equipment failures or malfunctions.
  - Install the product on a flat surface. If the mounting surface is rough, undue force will be applied to the PC board, thereby causing nonconformities.
  - Install the product securely using a DIN rail or mounting screws.
  - Connect the expansion board and expansion adapter securely to their designated connectors. Loose connections may cause malfunctions.
  - Make sure to affix the expansion board with tapping screws. Tightening torque should follow the specifications in the user's manual (Hardware) of the CPU module used. If the screws are tightened outside of the specified torque range, poor connections may cause malfunctions.
  - Work carefully when using a screwdriver such as installation of the product. Failure to do so may cause damage to the product or accidents.
  - Connect the extension cables, peripheral cables, input/output cables and battery connecting cable securely to their designated connectors. Loose connections may cause malfunctions.
  - When using an SD memory card, insert it into the SD memory card slot. Check that it is inserted completely. Poor contact may cause malfunction.
  - Turn off the power to the programmable controller before attaching or detaching the following devices. Failure to do so may cause equipment failures or malfunctions.
    - Peripheral devices, expansion board, expansion adapter, and connector conversion adapter
    - Extension modules, bus conversion module, and connector conversion module
    - Battery
  - Hold the connector part of the Ethernet cable and perform installation or removal in a straight direction. If the cable is pulled out while connected to the module, it may cause damage to the module or the cable, or may cause a malfunction due to poor connector contact.
-

## [Wiring Precautions]

---

### **WARNING**

- Make sure to cut off all phases of the power supply externally before attempting installation or wiring work. Failure to do so may cause electric shock or damage to the product.
  - Make sure to attach the terminal cover, provided as an accessory, before turning on the power or initiating operation after installation or wiring work. Failure to do so may cause electric shock.
  - The temperature rating of the cable should be 80°C or more.  
It may differ depending on the extension devices. For details, refer to the user's manual of the extension devices.
  - Make sure to wire the screw terminal block in accordance with the following precautions. Failure to do so may cause electric shock, equipment failures, a short-circuit, wire breakage, malfunctions, or damage to the product.
    - The disposal size of the cable end should follow the dimensions described in the user's manual (Hardware) of the CPU module used.
    - Tightening torque should follow the specifications in the user's manual (Hardware) of the CPU module used.
    - Tighten the screws using a Phillips-head screwdriver No.2 (shaft diameter 6 mm or less). Ensure that the screwdriver does not touch the partition part of the terminal block.
  - Make sure to properly wire to the terminal block (European type) in accordance with the following precautions. Failure to do so may cause electric shock, equipment failures, a short-circuit, wire breakage, malfunctions, or damage to the product.
    - The disposal size of the cable end should follow the dimensions described in the user's manual (Hardware) of the CPU module used.
    - Tightening torque should follow the specifications in the user's manual (Hardware) of the CPU module used.
    - Twist the ends of stranded wires and ensure that there are no loose wires.
    - Do not solder-plate the electric wire ends.
    - Do not connect more than the specified number of wires or electric wires of unspecified size.
    - Affix the electric wires so that neither the terminal block nor the connected parts are directly stressed.
  - Make sure to properly wire to the spring clamp terminal block in accordance with the following precautions. Failure to do so may cause electric shock, equipment failures, a short-circuit, wire breakage, malfunctions, or damage to the product.
    - The disposal size of the cable end should follow the dimensions described in the user's manual (Hardware) of the CPU module used.
    - Twist the ends of stranded wires and ensure that there are no loose wires.
    - Do not solder-plate the electric wire ends.
    - Do not connect more than the specified number of wires or electric wires of unspecified size.
    - Affix the electric wires so that neither the terminal block nor the connected parts are directly stressed.
-

## [Wiring Precautions]

---

### CAUTION

- Do not supply power externally to the [24 +] and [24 V] terminals (24 V DC service power supply) on the CPU module or extension modules. Doing so may damage the product. Note that power may be supplied even when an electronic load which equips with an internal bias power supply is connected.
  - Perform class D grounding (grounding resistance: 100  $\Omega$  or less) of the grounding terminal on the CPU module and extension modules with a wire 2 mm<sup>2</sup> or thicker.  
Do not use common grounding with heavy electrical systems. For details, refer to the user's manual (Hardware) of the CPU module used.
  - Connect the power supply wiring to the dedicated terminals described in the user's manual (Hardware) of the CPU module used. If an AC power supply is connected to a DC input/output terminal or DC power supply terminal, the programmable controller will burn out.
  - Do not wire vacant terminals externally. Doing so may damage the product.
  - Install module so that excessive force will not be applied to terminal blocks, power connectors, I/O connectors, communication connectors, or communication cables. Failure to do so may result in wire damage/breakage or programmable controller failure.
  - Make sure to observe the following precautions to prevent any damage to the machinery or accidents due to malfunction of the programmable controller caused by abnormal data written to the programmable controller due to the effects of noise.
    - Do not bundle the power line, control line and communication cables together with or lay them close to the main circuit, high-voltage line, load line or power line. As a guideline, lay the power line, control line and communication cables at least 100 mm away from the main circuit, high-voltage line, load line or power line.
    - Ground the shield of the shield wire or shielded cable at one point on the programmable controller. However, do not use common grounding with heavy electrical systems.
    - Ground the shield of the analog I/O wire in accordance with the manuals of each model. However, do not use common grounding with heavy electrical systems.
  - For Ethernet cables to be used in the system, select the ones that meet the specifications in this manual. If not, normal data transmission is not guaranteed.
-

## [Startup and Maintenance Precautions]

---

### **WARNING**

- Do not touch any terminal while the programmable controller's power is on. Doing so may cause electric shock or malfunctions.
- Before cleaning or retightening terminals, cut off all phases of the power supply externally. Failure to do so in the power ON status may cause electric shock.
- Before modifying the program, performing forced output, or running or stopping the programmable controller while the system is running, read through this manual carefully, and ensure complete safety. An operation error may damage the machinery or cause accidents.
- Do not change the program in the programmable controller from two or more peripherals at the same time. (such as from an engineering tool and a GOT) Doing so may cause destruction or malfunction of the programmable controller program.
- Once a program has been created, ensure the applicability and confirm that it will not cause system control problems. Failure to do so may cause the system to malfunction due to a setting error in the programmable controller.
- Use the battery for memory backup in conformance to the user's manual (Hardware) of the CPU module used.
  - Use the battery for the specified purpose only.
  - Connect the battery correctly.
  - Do not charge, disassemble, heat, put in fire, short-circuit, connect reversely, solder, swallow, or burn the battery, or apply excessive forces (vibration, impact, drop, etc.) to the battery.
  - Do not store or use the battery at high temperatures or expose to direct sunlight.
  - Do not expose to water, bring near fire or touch liquid leakage or other contents directly.
  - When replacing the battery, make sure to use our specified product (FX3U-32BL).
  - When a battery error occurs ("BAT" LED is on in red), follow the description in the user's manual (Hardware) of the CPU module used.

Incorrect handling of the battery may cause excessive heat generation, bursting, ignition, liquid leakage or deformation, and lead to injury, fire or failures and malfunction of facilities and other equipment.

---

## [Startup and Maintenance Precautions]

---

### CAUTION

- Do not disassemble or modify the programmable controller. Doing so may cause fire, equipment failures, or malfunctions.  
For repair, contact your local Mitsubishi Electric representative.
  - After the first use of the SD memory card, do not insert/remove the memory card more than 500 times. Doing so 500 times or more may cause malfunction.
  - Turn off the power to the programmable controller before connecting or disconnecting any extension cable. Failure to do so may cause equipment failures or malfunctions.
  - Turn off the power to the programmable controller before attaching or detaching the following devices. Failure to do so may cause equipment failures or malfunctions.
    - Peripheral devices, expansion board, expansion adapter, and connector conversion adapter
    - Extension modules, bus conversion module, and connector conversion module
    - Battery
  - Do not use the chemicals for cleaning.
  - If there is the possibility of touching the programmable controller inside a control panel in maintenance, make sure to discharge to avoid the influence of static electricity.
  - Since there are risks such as burn injuries, please do not touch the surface of the equipment with bare hands when it is operating in an environment which exceeds ambient temperature of 50°C.
- 

## [Operating Precautions]

---

### CAUTION

- Construct an interlock circuit in the program so that the whole system always operates on the safe side before executing the control (for data change) of the programmable controller in operation. Read the manual thoroughly and ensure complete safety before executing other controls (program change, parameter change, forced output, and operation status change) to the programmable controller in operation. Improper operation may damage machines or cause accidents.
  - Do not send safety-related data. Note that the data may not be sent due to factors such as power off of the programmable controller during data transmission.
- 

## [Disposal Precautions]

---

### CAUTION

- When disposing of this product, treat it as industrial waste.
  - When disposing of batteries, separate them from other waste according to local regulations. (For details on the Battery Directive in EU countries, refer to the user's manual (Hardware) of the CPU module used.)
-

## [Transportation Precautions]

---

### CAUTION

---

- When transporting the programmable controller with the optional battery, turn on the programmable controller before shipment, confirm that the battery mode is set using a parameter and the BAT LED is off, and check the battery life. If the programmable controller is transported with the BAT LED ON or the battery exhausted, the battery-backed data may be unstable during transportation.
  - The programmable controller is a precision instrument. During transportation, avoid impacts larger than those specified in the general specifications by using dedicated packaging boxes and shock-absorbing pallets. Failure to do so may cause failures in the programmable controller. After transportation, verify operation of the programmable controller and check for damage of the mounting part, etc. For details on the general specifications, refer to the user's manual (Hardware) of the CPU module used.
  - When transporting lithium batteries, follow required transportation regulations. (For details on the regulated products, refer to the user's manual (Hardware) of the CPU module used.)
  - The halogens (such as fluorine, chlorine, bromine, and iodine), which are contained in a fumigant used for disinfection and pest control of wood packaging materials, may cause failure of the product. Prevent the entry of fumigant residues into the product or consider other methods (such as heat treatment) instead of fumigation. The disinfection and pest control measures must be applied to unprocessed raw wood.
-

# INTRODUCTION

Thank you for purchasing the Mitsubishi Electric MELSEC iQ-F series programmable controllers.

This manual describes the performance specifications, procedures before operation, and wiring of the relevant products listed below. Before using this product, please read this manual and the relevant manuals carefully and develop familiarity with the functions and performance of the MELSEC iQ-F series programmable controller to handle the product correctly.

When applying the program examples provided in this manual to an actual system, ensure the applicability and confirm that it will not cause system control problems.

Please make sure that the end users read this manual.

## Relevant products

FX5-40SSC-S, FX5-80SSC-S, FX5-40SSC-G, FX5-80SSC-G

### Point

Symbols used in this manual are shown below.

A serial No. is inserted in the """" mark.

- [Pr.\*\*]: Symbols indicating positioning parameter or home position return parameter items
- [Da.\*\*]: Symbols indicating positioning data or block start data items
- [Md.\*\*]: Symbols indicating monitor data items
- [Cd.\*\*]: Symbols indicating control data items
- [FX5-SSC-S]: Symbols indicating compatibility with only FX5-SSC-S
- [FX5-SSC-G]: Symbols indicating compatibility with only FX5-SSC-G

## Regarding use of this product

- This product has been manufactured as a general-purpose part for general industries, and has not been designed or manufactured to be incorporated in a device or system used in purposes related to human life.
- Before using the product for special purposes such as nuclear power, electric power, aerospace, medicine or passenger movement vehicles, consult Mitsubishi Electric.
- This product has been manufactured under strict quality control. However, when installing the product where major accidents or losses could occur if the product fails, install appropriate backup or failsafe functions in the system.

## Note

- If in doubt at any stage during the installation of the product, always consult a professional electrical engineer who is qualified and trained in the local and national standards. If in doubt about the operation or use, please consult the nearest Mitsubishi Electric representative.
- Since the examples indicated by this manual, technical bulletin, catalog, etc. are used as a reference, please use it after confirming the function and safety of the equipment and system. Mitsubishi Electric will accept no responsibility for actual use of the product based on these illustrative examples.
- This manual content, specification etc. may be changed, without a notice, for improvement.
- The information in this manual has been carefully checked and is believed to be accurate; however, if you notice a doubtful point, an error, etc., please contact your local Mitsubishi Electric representative. When doing so, please provide the manual number given at the end of this manual.

# CONTENTS

WHEN USING AN INDUSTRIAL SWITCH WITH CC-Link IE TSN .....	1
SAFETY PRECAUTIONS .....	1
INTRODUCTION .....	11
RELEVANT MANUALS .....	14
TERMS .....	15
GENERIC TERMS AND ABBREVIATIONS .....	18
PERIPHERALS .....	19
<b>CHAPTER 1 PART NAMES</b> .....	<b>21</b>
1.1 LED Display Specifications .....	23
<b>CHAPTER 2 SPECIFICATIONS</b> .....	<b>25</b>
2.1 General Specifications .....	25
2.2 Power Supply Specifications .....	25
2.3 Performance Specifications .....	25
2.4 Specifications of Interfaces with External Devices [FX5-SSC-S] .....	27
Electrical specifications of input signals .....	27
2.5 External Circuit Design .....	29
<b>CHAPTER 3 FUNCTION LIST</b> .....	<b>46</b>
3.1 Control Functions .....	46
Main functions .....	46
Sub functions .....	49
Common functions .....	51
3.2 Combination of Main Functions and Sub Functions .....	52
3.3 Network Function List [FX5-SSC-G] .....	58
<b>CHAPTER 4 PROCEDURES BEFORE OPERATIONS</b> .....	<b>59</b>
<b>CHAPTER 5 WIRING</b> .....	<b>61</b>
5.1 Wiring [FX5-SSC-S] .....	61
Precautions .....	61
5.2 Wiring [FX5-SSC-G] .....	67
Wiring for CC-Link IE TSN .....	67
Precautions .....	69
5.3 Power Supply Wiring .....	70
5.4 Grounding .....	71
5.5 External Input Connection Connector [FX5-SSC-S] .....	72
Signal layout for external input connection connector .....	72
List of input signal details .....	73
Interface internal circuit .....	74
<b>APPENDICES</b> .....	<b>77</b>
Appendix 1 Component List [FX5-SSC-S] .....	77
Reference product .....	77
Appendix 2 Component List [FX5-SSC-G] .....	85
Appendix 3 Connection with External Devices [FX5-SSC-S] .....	86
Connector .....	86

External input signal cable . . . . .	87
<b>Appendix 4 How to Check the SERIAL No. . . . .</b>	<b>90</b>
<b>Appendix 5 External Dimensions . . . . .</b>	<b>91</b>
<b>Appendix 6 Standard Compliant Models . . . . .</b>	<b>93</b>
Models compliant with UL and cUL standards. . . . .	93
EU Directive (CE marking) compliance . . . . .	93
Measures to comply with the EMC Directive . . . . .	93
Precautions for compliance with the EU Directive. . . . .	94
Compliance with UKCA marking . . . . .	94
<b>Appendix 7 Open Source Software . . . . .</b>	<b>95</b>
<b>Appendix 8 Operation Examples . . . . .</b>	<b>97</b>
Operation example [FX5-SSC-S] . . . . .	97
Program Examples Using Labels [FX5-SSC-S] . . . . .	100
Program Examples Using Buffer Memory [FX5-SSC-S] . . . . .	104
<b>Appendix 9 Setting Example for Motion Modules [FX5-SSC-G] . . . . .</b>	<b>110</b>
<b>INDEX . . . . .</b>	<b>120</b>
<hr/>	
REVISIONS . . . . .	122
WARRANTY . . . . .	123
INFORMATION AND SERVICES . . . . .	124
TRADEMARKS . . . . .	124

# RELEVANT MANUALS

The following manuals are relevant to this product.

Manual name [manual number]	Description
MELSEC iQ-F FX5 Motion Module/Simple Motion Module User's Manual (Startup) [IB-0300251ENG] (This manual)	Specifications, procedures before operation, system configuration, wiring, and operation examples of the Motion module/Simple Motion module
MELSEC iQ-F FX5 Motion Module/Simple Motion Module User's Manual (Application) [IB-0300253ENG]	Functions, input/output signals, buffer memories, parameter settings, programming, and troubleshooting of the Motion module/Simple Motion module
MELSEC iQ-F FX5 Motion Module/Simple Motion Module User's Manual (Advanced Synchronous Control) [IB-0300255ENG]	Functions and programming for the synchronous control of the Motion module/Simple Motion module
MELSEC iQ-F FX5 Motion Module User's Manual (CC-Link IE TSN) [IB-0300568ENG]	Functions, parameter settings, troubleshooting, and buffer memories of the CC-Link IE TSN network
MELSEC iQ-F FX5 Motion Module/Simple Motion Module Function Block Reference [BCN-B62005-719]	Specifications, functions, and input/output labels of function blocks for the Motion module/Simple Motion module

This manual does not include detailed information on the following:

- General specifications
- Available CPU modules and the number of mountable modules
- Installation

For details, refer to the following.

 MELSEC iQ-F FX5S/FX5UJ/FX5U/FX5UC User's Manual (Hardware)

# TERMS

Unless otherwise specified, this manual uses the following terms.

Term	Description
4-axis module	Another term for FX5-40SSC-S and FX5-40SSC-G.
8-axis module	Another term for FX5-80SSC-S and FX5-80SSC-G.
Axis	A target for motion control.
Buffer memory	A memory in an intelligent function module, where data (such as setting values and monitoring values) are stored.
CANopen	An open network whose standards are promoted by the non-profit organization CiA. An application layer is defined in which communication profiles and device profiles are defined, and this application layer is applied to the CC-Link IE TSN CAN application protocol.
CC-Link	One of the field-based networks that can handle control and information at the same time.
CC-Link IE Controller Network	One of the control system networks. A backbone network that supports large-scale distributed controller control and bundles field and motion networks.
CC-Link IE Field Basic Network	A network that achieves cyclic transmission by software. Applicable to small-scale equipment that does not require high-speed control.
CC-Link IE Field Network	A high speed and large capacity open field network that is based on Ethernet (1000BASE-T).
CC-Link IE TSN	An open network that uses "TSN (Time-Sensitive Networking)", which is an extension of the Ethernet standard, to ensure real-time control and handle information from other open networks simultaneously.
CC-Link IE TSN Class	A group of devices and industrial switches with CC-Link IE TSN, classified according to the functions and performance by the CC-Link Partner Association. For CC-Link IE TSN Class, refer to the CC-Link IE TSN Installation Manual (BAP-C3007ENG-001) published by the CC-Link Partner Association.
CC-Link IE TSN Protocol version 2.0	In addition to the time sharing method using IEEE802.1AS for time synchronization, this protocol communicates using the time managed polling method.
Command generation axis	An axis that performs only command generation. "Command generation axis" is not included in the number of controlled axes of the controller.
Communication cycle	Cyclic transmission communication cycle of the cyclic master.
Control station	Station that controls the network on CC-Link IE controller network. Only one station per network. The control station performs cyclic transmission with each station according to the station transmission range assigned by the user.
Cyclic transmission	A function by which data is periodically exchanged among stations on the network.
Dedicated instruction	An instruction for using functions of the module.
Device	Various types of memory in a module. Some devices are handled in units of bits and some in units of words.
Disconnection	A process of stopping data link if a data link error occurs.
Extension module	CC-Link IE Remote module without TSN network communication function. In the case of a multi-axis servo amplifier, axes other than axis A are extension modules.
Field network	Network used to efficiently control various sensors and drive systems with less wiring in the factory automation field.
Gateway	In general, protocol conversion is required to connect networks that differ from each other due to differences in signaling methods and functions. This function bridges these different networks to enable mutual communication.
Global label	A label that is enabled for all program data when creating multiple program data in the project. There are two types of global label: a module specific label (module label), which is generated automatically by GX Works3, and an optional label, which can be created for any specified device.
Grandmaster	A source device or station to synchronize clocks in the time synchronization via PTP (Precision Time Protocol).
GX Works3	The product name of the software package for the MELSEC programmable controllers.
IEEE802.1AS	A protocol for high precision time/timing synchronization.
Intelligent device station	A station that exchanges I/O signals (bit data) and I/O data (word data) with another station by cyclic transmission on CC-Link IE Field Network. This station can perform transient transmission. This station responds to a transient transmission request from another station and also issues a transient transmission request to another station.
Industrial switch (for CC-Link IE TSN Class A)	A CC-Link IE TSN Class A industrial switch certified by CC-Link Partner Association.
Industrial switch (for CC-Link IE TSN Class B)	A CC-Link IE TSN Class B industrial switch certified by CC-Link Partner Association.
Intelligent function module	A module that has functions other than input and output, such as an A/D converter module and D/A converter module.
IP communication	A function to send and receive data via standard Ethernet protocols (TCP/IP, UDP/IP, FTP, etc.).

Term	Description
Label	A variable used in a program.
Line topology	A form of networking in which multiple devices are connected in a line.
Link dedicated instruction	Dedicated instruction for the programmable controller to send messages to the specified station using transient transmission.
Link device	A device in a module on CC-Link IE TSN.
Link down	Status in which the communication cable is disconnected or not connected, and communication with the destination device is disabled.
Link refresh	Automatic data transfer between a link device of the Motion module and CPU module devices.
Link up	Status in which the cable is connected to the communication port and communication with the destination device is enabled.
Local station	A station that performs cyclic transmission and transient transmission with the master station and other local stations.
Master station	A station that controls a network. Only one station exists per network. The transmission range of each station for cyclic transmission is assigned to the master station.
Module label	A label that represents one of memory areas (I/O signals and buffer memory areas) specific to each module in a given character string. From the module used, GX Works3 automatically generates this label, which can be used as a global label in the CPU module.
Motion control station	A device station that exchanges cyclic data by motion control.
Motion network	A network for high performance/functional drive control. (SSCNET, etc.)
MR Configurator2	The product name of the setup software for the servo amplifier.
MR-J3(W)-B	Servo amplifier model MR-J3-_B_(-RJ)/MR-J3W-_B_.
MR-J4(W)-B	Servo amplifier model MR-J4-_B_(-RJ)/MR-J4W-_B_.
MR-J4W2-B	Servo amplifier model MR-J4W2-_B_.
MR-J4-B	Servo amplifier model MR-J4-_B_.
MR-J4-B-RJ	Servo amplifier model MR-J4-_B_-RJ.
MR-J5(W)-B	Servo amplifier model MR-J5-_B_(-RJ)/MR-J5W-_B_.
MR-J5W2-B	Servo amplifier model MR-J5W2-_B_.
MR-J5-B-RJ	Servo amplifier model MR-J5-_B_-RJ.
MR-J5-G	Servo amplifier model MR-J5-_G_(-RJ).
MR-J5(W)-G	Servo amplifier model MR-J5-_G_(-RJ)/MR-J5W-_G_/MR-J5D-_G_.
MR-JE-B(F)	Servo amplifier model MR-JE-_B_(F).
MR-JET-G	Servo amplifier model MR-JET-_G_.
Network map	Diagram that shows the types of masters and device stations, and their wiring information that configure the network system.
Node	Nodal point at the time of the data link.
Object	Various data held by the CANopen-compatible device station.
PDO mapping	Write operation to the PDO mapping object (RPDO/TPDO) at the device station, which determines the number of PDO allocated to the device and the assignment of objects in the PDO.
Profile	A file that specifies the specific information of a device (model name, model name, etc.) and the information required for installation, operation, and maintenance.
Relay station	A station that relays data link to other station. Link device data of a network module are transferred to another network module via this station. Multiple network modules are connected to one programmable controller.
Remote device station	A station that exchanges I/O signals (bit data) and I/O data (word data) with another station by cyclic transmission on CC-Link IE Field Network. This station responds to a transient transmission request from another station.
Remote I/O station	A station that exchanges I/O signals (bit data) with the master station by cyclic transmission on CC-Link IE Field Network.
Remote station	A station that performs bit basis and word basis cyclic and transient transmissions with the master station on CC-Link IE TSN network.
Ring topology	A form of networking in which multiple devices are connected in a ring.
Safety main module	Different name for FX5-SF-MU4T5.
Servo amplifier axis	A servo amplifier or virtual servo amplifier controlled by a controller. "Servo amplifier axis" is included in the number of controlled axes of the controller.
SSCNET III <sup>*1</sup>	High speed synchronous communication network between Simple Motion module and servo amplifier.
SSCNET III/H <sup>*1</sup>	
Standard station	A device station other than a motion control station.
Star topology	A form of network in which multiple devices are connected radially from an industrial switch.

<b>Term</b>	<b>Description</b>
Station	Each of the nodes connected to the network is called a station.
Station No.	Each station is numbered and this number is called the station No.
TCP/IP	One of the communication protocols that operate on IP. It is highly reliable since a connection between the send source and destination is established before sending and receiving data.
Time sharing	A method in which a communication line is divided into fixed time intervals and different data is sent and received at each interval.
Time synchronization	The clocks of each station are synchronized to the clock of the grand master (the clock source station).
Transient transmission	A function of non-periodic data communication among nodes (station) on network. A function used to send messages to the target station when requested by a link dedicated instruction or the engineering tool. Communication is available with station on another network via relay station, or gateway.
UDP/IP	One of the communication protocols that operate on IP. The communication speed is high since data is sent without establishing a connection between the send source and destination.
VLAN	Configuration of a virtual network separate from the physical connection form.

\*1 SSCNET: Servo System Controller NETwork

# GENERIC TERMS AND ABBREVIATIONS

Unless otherwise specified, this manual uses the following generic terms and abbreviations.

Generic term/abbreviation	Description
CC-Link IE	A generic term for CC-Link IE Field Network, CC-Link IE Controller Network, CC-Link IE Field Basic Network, and CC-Link IE TSN network.
CPU module	An abbreviation for the MELSEC iQ-F series CPU module.
Data link	A generic term for a cyclic transmission and a transient transmission.
Devices compatible with CC-Link IE TSN	A generic term for devices certified as CC-Link IE TSN Class A or CC-Link IE TSN Class B by CC-Link Partner Association.
Device station	A generic term for a local station and remote station on CC-Link IE TSN.
Drive unit	A generic term for motor drive devices such as a servo amplifier.
Engineering tool	A generic term for GX Works3 and MR Configurator2.
Ethernet-compatible device	A generic term for the devices supporting IP communication (such as a personal computer, a vision sensor, and a bar code reader).
FB	An abbreviation for function blocks. A graphical programming language for programmable controllers that is one of the five languages defined in the IEC 61131-3 standard.
FTP	An abbreviation for File Transfer Protocol. This protocol is used to transfer data files over a network.
FX5-SSC-G	A generic term for the FX5-40SSC-G and FX5-80SSC-G Motion module.
FX5-SSC-S	A generic term for the FX5-40SSC-S and FX5-80SSC-S Simple Motion module.
GOT	An abbreviation for Graphic Operation Terminal. A display device for industrial (FA) equipment.
Manual pulse generator	An abbreviation for a (user-arranged) manual pulse generator.
Motion module	An abbreviation for the MELSEC iQ-F series Motion module.
Motion system	A generic term for software that performs the motion control and the network control.
Network module	A generic term for the following modules: <ul style="list-style-type: none"> <li>• Ethernet interface module</li> <li>• Module on CC-Link IE TSN (the Motion module and a module on a remote station)</li> <li>• CC-Link IE Controller Network module</li> <li>• Module on CC-Link IE Field Network (a master/local module, and a module on a remote I/O station, a remote device station, and an intelligent device station)</li> <li>• MELSECNET/H network module</li> <li>• MELSECNET/10 network module</li> </ul>
PDO	An abbreviation for Process Data Object. A collection of the application objects transmitted periodically between multiple CANopen nodes.
PTP	An abbreviation for Precision Time Protocol. A predefined protocol for time synchronization between devices on a network.
Safety expansion module	A generic term for expansion modules installed to a safety main module.
Safety extension module	A generic term for safety main modules and safety expansion modules.
Servo network	A generic term for the network between the Simple Motion module/Motion module and drive units. <ul style="list-style-type: none"> <li>• SSCNET III/H, SSCNET III</li> <li>• CC-Link IE TSN</li> </ul>
Simple Motion module	An abbreviation for the MELSEC iQ-F series Simple Motion module.
SSCNET III(/H)	A generic term for SSCNET III/H, SSCNET III.

# PERIPHERALS

## Peripherals for FX5-SSC-S

The following figure shows the peripherals when the FX5-SSC-S is used.

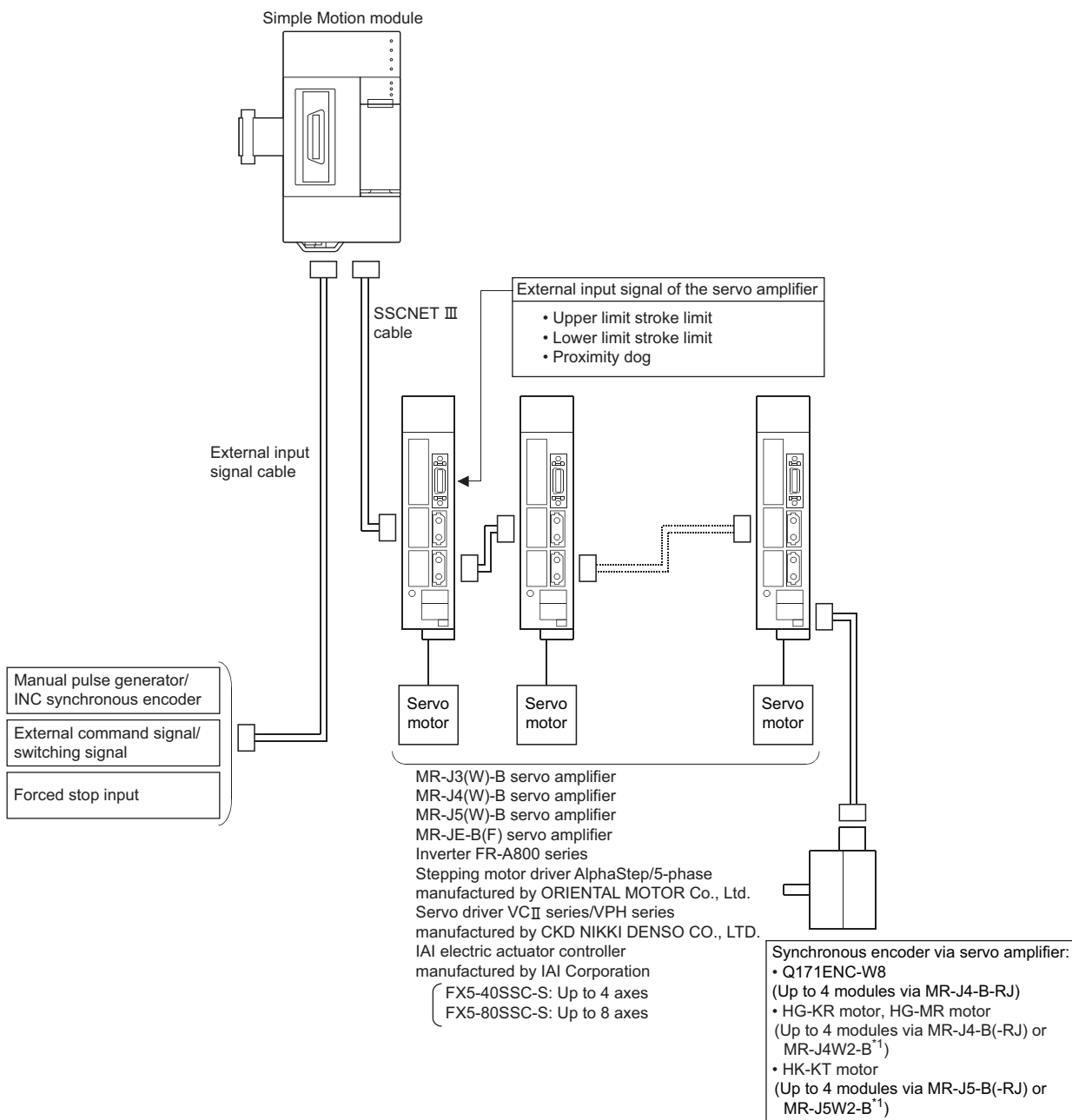

\*1 Use the servo amplifier which supports the scale measurement function.  
 Refer to the manuals for the version of the servo amplifier which supports the scale measurement function and the encoder which can be used with the scale measurement function.



The external input signal might not be usable depending on the connected device. Confirm the specification of the connected device.

## Peripherals for FX5-SSC-G

The following figure shows the peripherals when the FX5-SSC-G is used.

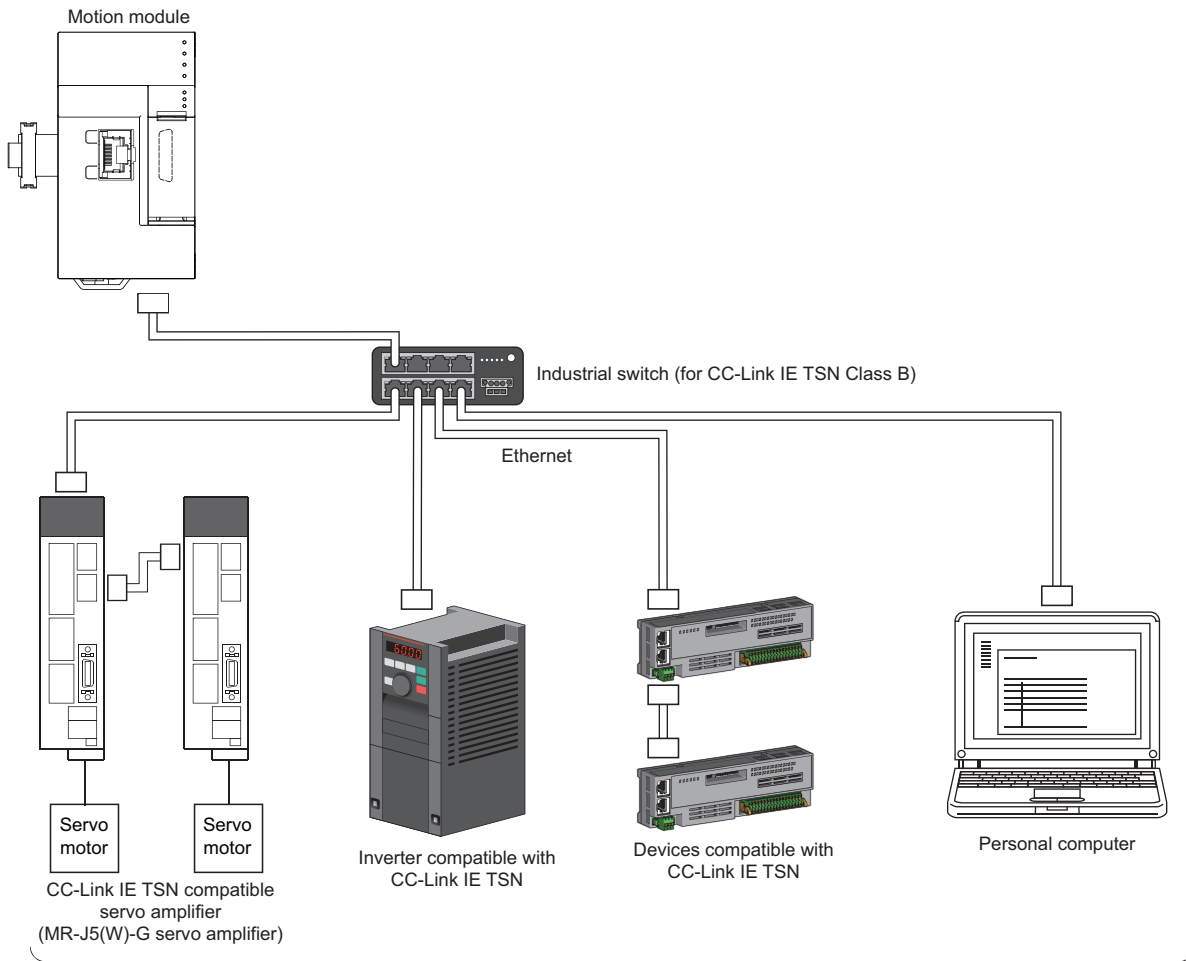

FX5-40SSC-G: Up to 4 Motion control stations + 16 standard stations  
 FX5-80SSC-G: Up to 8 Motion control stations + 16 standard stations

Using the table below, refer to the manual that is appropriate for the input signal to be used.

Input signal	Reference
<ul style="list-style-type: none"> <li>External command signal/switching signal</li> <li>Forced stop input signal</li> <li>Manual pulse generator input signal</li> </ul>	<ul style="list-style-type: none"> <li>MELSEC iQ-F FX5 Motion Module/Simple Motion Module User's Manual (Application)</li> </ul>
<ul style="list-style-type: none"> <li>Incremental synchronous encoder input signal</li> </ul>	<ul style="list-style-type: none"> <li>MELSEC iQ-F FX5 Motion Module/Simple Motion Module User's Manual (Advanced Synchronous Control)</li> </ul>

### Restriction

The Motion module cannot be used together with safety extension modules when the firmware version of the Motion module is Ver. "1.000". When using with safety extension modules together, connect the Motion module with the firmware version "1.000" or later. There are restrictions by the version when using together with the following intelligent function modules other than safety extension modules and the Motion modules.

- FX5-20PG-P ("1.011" or later)
- FX5-20PG-D ("1.011" or later)
- FX5-CCLGN-MS ("1.002" or later)
- FX5-DP-M ("1.001" or later)

For details, refer to the following manual.

- MELSEC iQ-F FX5S/FX5UJ/FX5U/FX5UC User's Manual (Hardware)

# 1 PART NAMES

## Part names [FX5-SSC-S]

This chapter describes the part names of the FX5-SSC-S.

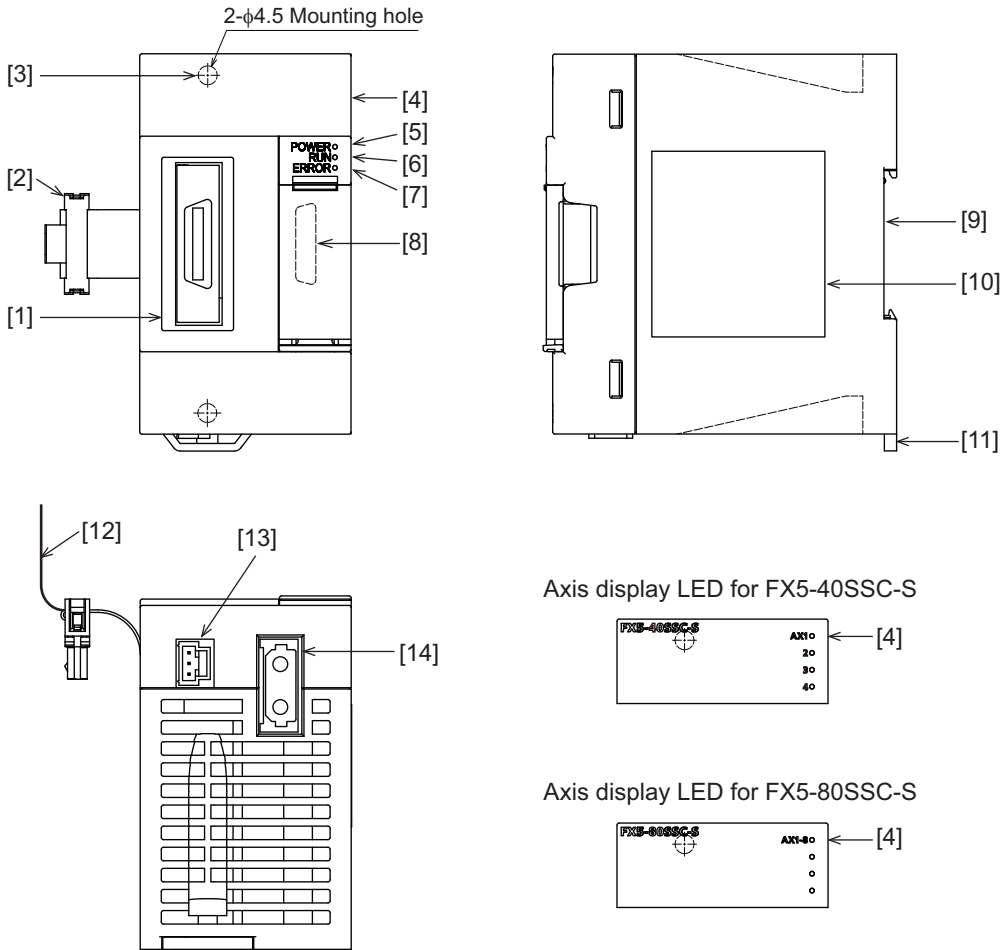

No.	Name	Description
[1]	External input connection connector	Connects to a mechanical system input, manual pulse generator/incremental synchronous encoder, or forced stop input. (26-pin connector) For the signal layout, refer to the following. ☞ Page 27 Specifications of Interfaces with External Devices [FX5-SSC-S]
[2]	Extension cable	Connects to a CPU module, etc.
[3]	Direct mounting hole: 2 holes of $\Phi 4.5$ (0.18") (mounting screw: M4 screw)	Holes which are used when installed directly.
[4]	Axis display LED	For details, refer to the following.
[5]	POWER LED	☞ Page 23 LED Display Specifications
[6]	RUN LED	
[7]	ERROR LED	
[8]	Extension connector	Connects to an expansion module on the next tier.
[9]	DIN rail mounting groove	Using this slot, the module can be mounted to DIN rail "DIN46277" (width: 35 mm (1.38 inch)).
[10]	Rating plate	Serial No. etc., are printed.
[11]	DIN rail mounting hook	Hook which is used for mounting the module onto the DIN rail.
[12]	Pullout tab	Tab for removing from a CPU module, etc.
[13]	Power supply connector	Connects a module to the power.
[14]	SSCNET III cable connector	Connects to a servo amplifier.

## Part names [FX5-SSC-G]

This chapter describes the part names of the FX5-SSC-G.

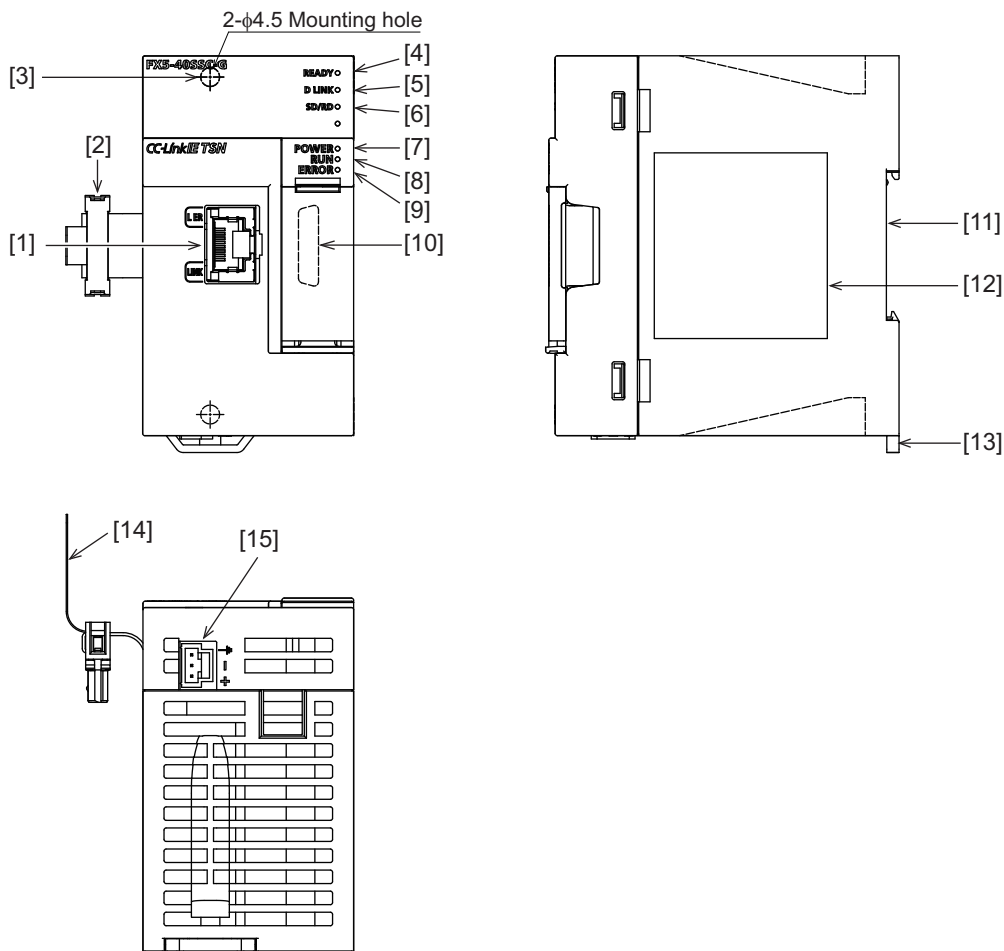

No.	Name	Description
[1]	Modular jack (RJ45) (with cap)	A port used to connect to CC-Link IE TSN. Connect an ethernet cable to this port. For the wiring and precautions when wiring, refer to the following. ☞ Page 67 Wiring [FX5-SSC-G]
[2]	Extension cable	Connects to a CPU module, etc.
[3]	Direct mounting hole: 2 holes of $\phi 4.5$ (0.18") (mounting screw: M4 screw)	Holes which are used when installed directly.
[4]	READY LED	For details, refer to the following. ☞ Page 24 LED display specifications [FX5-SSC-G]
[5]	D LINK LED	
[6]	SD/RD LED	
[7]	POWER LED	
[8]	RUN LED	
[9]	ERROR LED	
[10]	Extension connector	Connects to an expansion module on the next tier.
[11]	DIN rail mounting groove	Using this slot, the module can be mounted to DIN rail "DIN46277" (width: 35 mm (1.38 inch)).
[12]	Rating plate	Serial No. etc., are printed.
[13]	DIN rail mounting hook	Hook which is used for mounting the module onto the DIN rail.
[14]	Pullout tab	Tab for removing from a CPU module, etc.
[15]	Power supply connector	Connects a module to the power.

# 1.1 LED Display Specifications

## LED display specifications [FX5-SSC-S]

This section lists LED display specifications for FX5-SSC-S.

□: OFF, ■: ON, ●: Flashing

Simple Motion module status	LED display		Description
	4-axis module	8-axis module	
Normal operation	AX1 □ AX2 □ AX3 □ AX4 □	AX1-8 □ <sup>*3</sup>	The axes stopped The axes on standby
	POWER ■ <sup>*1</sup> RUN ■ ERROR □	POWER ■ <sup>*1</sup> RUN ■ ERROR □	
	AX1 ■ AX2 □ AX3 □ AX4 □	AX1-8 ■ <sup>*4</sup>	The axis in operation
	POWER ■ <sup>*1</sup> RUN ■ ERROR □	POWER ■ <sup>*1</sup> RUN ■ ERROR □	
Operation failure	AX1 ● <sup>*2</sup> AX2 □ AX3 □ AX4 □	AX1-8 ● <sup>*2*5</sup>	Minor error
	POWER ■ <sup>*1</sup> RUN ■ ERROR ■	POWER ■ <sup>*1</sup> RUN ■ ERROR ■	
	AX1 □ AX2 □ AX3 □ AX4 □	AX1-8 □	Moderate error Watchdog timer error
	POWER ■ <sup>*1</sup> RUN ■ ERROR ●	POWER ■ <sup>*1</sup> RUN ■ ERROR ●	

\*1 When the power is supplied for the Simple Motion module, the POWER LED turns ON. When the power is not supplied, all LEDs including the POWER LED turn OFF.

\*2 When an error occurs in the synchronous encoder axis or the command generation axis, only the ERROR LED operates. (The AX LED does not operate.)

\*3 When all axes are stopped or on standby, the AX LED turns OFF.

\*4 When any of the axes is in operation, the AX LED turns ON.

\*5 When an error occurs in any of the axes, the AX LED is flashing.

## LED display specifications [FX5-SSC-G]

This section lists LED display specifications for FX5-SSC-G.

□: OFF, ■: ON, ●: Flashing

LED	Description	LED display	Status
READY LED	Displays the PLC READY status.	READY ■	PLC READY ON
		READY □	PLC READY OFF
POWER LED	Displays the power status.	POWER ■	Power ON
		POWER □	Power OFF
RUN LED	Displays the operation status.	RUN ■	Normal operation
		RUN □	Error occurring
ERROR LED	Displays the error status.	ERROR ■	Error occurring
		ERROR ●	200 ms interval: error occurring 500 ms interval: erroneous data link station detected
		ERROR □	Normal operation
D LINK LED	Displays the data link status.	D LINK ■	Data link (cyclic transmission)
		D LINK ●	Data link (cyclic transmission stopped)
		D LINK □	Data link not started (released)
SD/RD LED	Displays the data transmit status.	SD/RD ■	Data <sup>*1</sup> transmission in progress
		SD/RD □	Data <sup>*1</sup> transmission not in progress
L ER LED	Displays the port status.	L ER ■	Abnormal data received
		L ER □	Normal data received
LINK LED	Displays the link status.	LINK ■	Link up
		LINK □	Link down

\*1 Includes cyclic transmission and transient transmission data for CC-Link IE TSN.

The error status can be categorized as shown below based on the ON status of the RUN LED and ERROR LED.

When multiple errors occur, the error status is displayed in the order of Major error > Moderate error > Minor error.

RUN LED	ERROR LED	Error status	Description
OFF	ON or flashing	Major error	An error in which the module stops operation because of a hardware error or memory error, etc.
ON	Flashing	Moderate error	An error related to module operation in which the module stops operation because of a parameter error, etc.
ON	ON	Minor error	An error, such as a communication, positioning control, or program error, in which the module continues operation.

# 2 SPECIFICATIONS

This chapter describes the specifications of the FX5-SSC-S/FX5-SSC-G.

## 2.1 General Specifications

General specifications except the following are the same as the connected CPU module. Refer to the CPU module User's Manual for the general specifications that can be used.

Items	Specifications	
Operating ambient temperature	0 to 55°C	
Dielectric withstand voltage	500 V AC for 1 minute	Between all terminals and ground terminal
Insulation resistance	10 MΩ or higher by 500 V DC insulation resistance tester	

## 2.2 Power Supply Specifications

Items		Specifications	
		FX5-SSC-S	FX5-SSC-G
External power supply	Power supply voltage	24 V DC +20% -15%	
	Allowable instantaneous power failure time	Operation continues when the instantaneous power failure is shorter than 5 ms.	
	Electricity consumption	6 W	5.8 W
	Power fuse	1 A	
Internal power supply	PLC power supply	Not used.	

## 2.3 Performance Specifications

This section lists the performance specifications.

Item	Description			
	FX5-40SSC-S	FX5-80SSC-S	FX5-40SSC-G	FX5-80SSC-G
Number of controlled axes	4 axes	8 axes	4 axes	8 axes
Operation cycle	0.888 ms/1.777 ms		0.500 ms/1.000 ms/2.000 ms/4.000 ms	
Interpolation function	2-, 3-, or 4-axis linear interpolation, 2-axis circular interpolation			
Control method	PTP (Point To Point) control, path control (both linear and arc can be set), speed control, speed-position switching control, position-speed switching control, speed-torque control			
Control unit	mm, inch, degree, pulse			
Positioning data	600 data/axis			
Execution data backup function	Parameters, positioning data, and block start data can be saved on flash ROM. (battery-less backup)			

Item		Description			
		FX5-40SSC-S	FX5-80SSC-S	FX5-40SSC-G	FX5-80SSC-G
Positioning	Positioning system	PTP control: Incremental system/absolute system Speed-position switching control: Incremental system/absolute system Position-speed switching control: Incremental system Path control: Incremental system/absolute system			
	Positioning range	In absolute system • -214748364.8 to 214748364.7 (μm) • -21474.83648 to 21474.83647 (inch) • 0 to 359.99999 (degree) • -2147483648 to 2147483647 (pulse) In incremental system • -214748364.8 to 214748364.7 (μm) • -21474.83648 to 21474.83647 (inch) • -21474.83648 to 21474.83647 (degree) • -2147483648 to 2147483647 (pulse) In speed-position switching control (INC mode)/position-speed switching control • 0 to 214748364.7 (μm) • 0 to 21474.83647 (inch) • 0 to 21474.83647 (degree) • 0 to 2147483647 (pulse) In speed-position switching control (ABS mode)*1 0 to 359.99999 (degree)			
	Speed command	0.01 to 20000000.00 (mm/min) 0.001 to 2000000.000 (inch/min) 0.001 to 2000000.000 (degree/min)*2 1 to 1000000000 (pulse/s)			
	Acceleration/deceleration process	Trapezoidal acceleration/deceleration, S-curve acceleration/deceleration			
	Acceleration/deceleration time	1 to 8388608 (ms) (Four patterns can be set for each of acceleration time and deceleration time.)			
	Sudden stop deceleration time	1 to 8388608 (ms)			
	Starting time*3	1.777 ms	<ul style="list-style-type: none"> <li>• For an operation cycle of 0.500 ms: 0.4 to 1.0 ms</li> <li>• For an operation cycle of 1.000 ms: 0.4 to 1.5 ms</li> <li>• For an operation cycle of 2.000 ms: 0.4 to 2.8 ms</li> <li>• For an operation cycle of 4.000 ms: 0.4 to 4.5 ms</li> </ul>		
External wiring connection system	26-pin connector	—			
Applicable wire size*4	AWG30 to 24 (0.05 to 0.2 mm <sup>2</sup> ) *4	—			
External input wiring connector	LD77MHIOCON	—			
Distance between stations (maximum)	SSCNETⅢ/H: 100 m (328.08 ft.) SSCNETⅢ: 50 m (164.04 ft.)	100 m (328.08 ft.)			
Manual pulse generator/Incremental synchronous encoder input maximum frequency	Differential-output type	Up to 1 Mpulses/s	—		
	Open-collector type	Up to 200 kpulses/s	—		
Manual pulse generator 1 pulse input magnification	1 to 10000 times				
Flash ROM write count	Max. 100000 times				
Number of occupied I/O points	8 points				
Mass	Approx. 0.3 kg				

\*1 The speed-position switching control (ABS mode) can be used only when the control unit is "degree".

\*2 When "Speed control 10 times multiplier setting for degree axis function" is valid, the setting range is 0.01 to 20000000.00 (degree/min).

\*3 Time from accepting the positioning start signal until BUSY signal turns ON.

\*4 AWG24 (0.2 mm<sup>2</sup>) is recommended.

## CC-Link IE TSN [FX5-SSC-G]

For details of the performance specifications of CC-Link IE TSN, refer to "Performance Specifications of CC-Link IE TSN" in the following manual.

 MELSEC iQ-F FX5 Motion Module User's Manual (CC-Link IE TSN)

## 2.4 Specifications of Interfaces with External Devices [FX5-SSC-S]

### Electrical specifications of input signals

2

#### External input signal/switching signal

##### ■ Specifications of external input signal/switching signal

Item	Specifications	
Signal name	Proximity dog signal External input signal/Switching signal	
Number of input points	4 points	
Input method	Positive common/Negative common shared	
Common terminal arrangement	4 points/common (Common contact: COM)	
Isolation method	Photocoupler	
Rated input voltage	24 V DC	
Rated input current ( $I_{IN}$ )	Approx. 5 mA	
Operating voltage range	19.2 to 26.4 V DC (24 V DC+10/-20%, ripple ratio 5% or less)	
ON voltage/current	17.5 V DC or more/3.5 mA or more	
OFF voltage/current	7 V DC or less/1 mA or less	
Input resistance	Approx. 6.8 k $\Omega$	
Response time	OFF $\rightarrow$ ON	1 ms or less
	ON $\rightarrow$ OFF	

#### Forced stop input

##### ■ Specifications of forced stop input signal

Item	Specifications	
Number of input points	1 point	
Input method	Positive common/Negative common shared	
Common terminal arrangement	1 point/common (Common contact: EMI.COM)	
Isolation method	Photocoupler	
Rated input voltage	24 V DC	
Rated input current ( $I_{IN}$ )	Approx. 5 mA	
Operating voltage range	19.2 to 26.4 V DC (24 V DC+10/-20%, ripple ratio 5% or less)	
ON voltage/current	17.5 V DC or more/3.5 mA or more	
OFF voltage/current	7 V DC or less/1 mA or less	
Input resistance	Approx. 6.8 k $\Omega$	
Response time	OFF $\rightarrow$ ON	4 ms or less
	ON $\rightarrow$ OFF	

## Manual pulse generator/Incremental synchronous encoder input

### ■ Specifications of manual pulse generator/incremental synchronous encoder

Item	Specifications	
Signal input form* <sup>1</sup>	A-phase/B-phase (Magnification by 4/Magnification by 2/Magnification by 1), PULSE/SIGN	
Differential-output type (26LS31 or equivalent)	Maximum input pulse frequency	1 Mpulses/s (After magnification by 4, up to 4 Mpulses/s) <sup>*2</sup>
	Pulse width	1 μs or more
	Leading edge/trailing edge time	0.25 μs or less
	Phase difference	0.25 μs or more
	Rated input voltage	5.5 V DC or less
	High-voltage	2.0 to 5.25 V DC
	Low-voltage	0 to 0.8 V DC
	Differential voltage	±0.2 V
	Cable length	Up to 30 m (98.43 ft.)
	Example of waveform	
Voltage-output type/Open-collector type (5 V DC)	Maximum input pulse frequency	200 kpulses/s (After magnification by 4, up to 800 kpulses/s) <sup>*2</sup>
	Pulse width	5 μs or more
	Leading edge/trailing edge time	1.2 μs or less
	Phase difference	1.2 μs or more
	Rated input voltage	5.5 V DC or less
	High-voltage	3.0 to 5.25 V DC/2 mA or less
	Low-voltage	0 to 1.0 V DC/5 mA or more
	Cable length	Up to 10 m (32.81 ft.)
	Example of waveform	

\*1 Set the signal input form in "[Pr.24] Manual pulse generator/Incremental synchronous encoder input selection".

[Pr.24] Manual pulse generator/Incremental synchronous encoder input selection	[Pr.151] Manual pulse generator/Incremental synchronous encoder input logic selection	
	Positive logic	Negative logic
A-phase/B-phase	<p>Forward run      Reverse run</p>	<p>Forward run      Reverse run</p>
PULSE/SIGN	<p>Forward run      Reverse run</p> <p>HIGH      LOW</p>	<p>Forward run      Reverse run</p> <p>LOW      HIGH</p>

\*2 Maximum input pulse frequency is magnified by 4, when "A-phase/B-phase Magnification by 4" is set in "[Pr.24] Manual pulse generator/Incremental synchronous encoder input selection".

## 2.5 External Circuit Design

---

Configure up the power supply circuit and main circuit which turn off the power supply after detection alarm occurrence and servo forced stop. When designing the main circuit of the power supply, make sure to use a circuit breaker (MCCB). The outline diagrams for the external device connection interface are shown below.

# External circuit design [FX5-SSC-S]

## Example when using the forced stop of the Simple Motion module (For MR-J4-B)

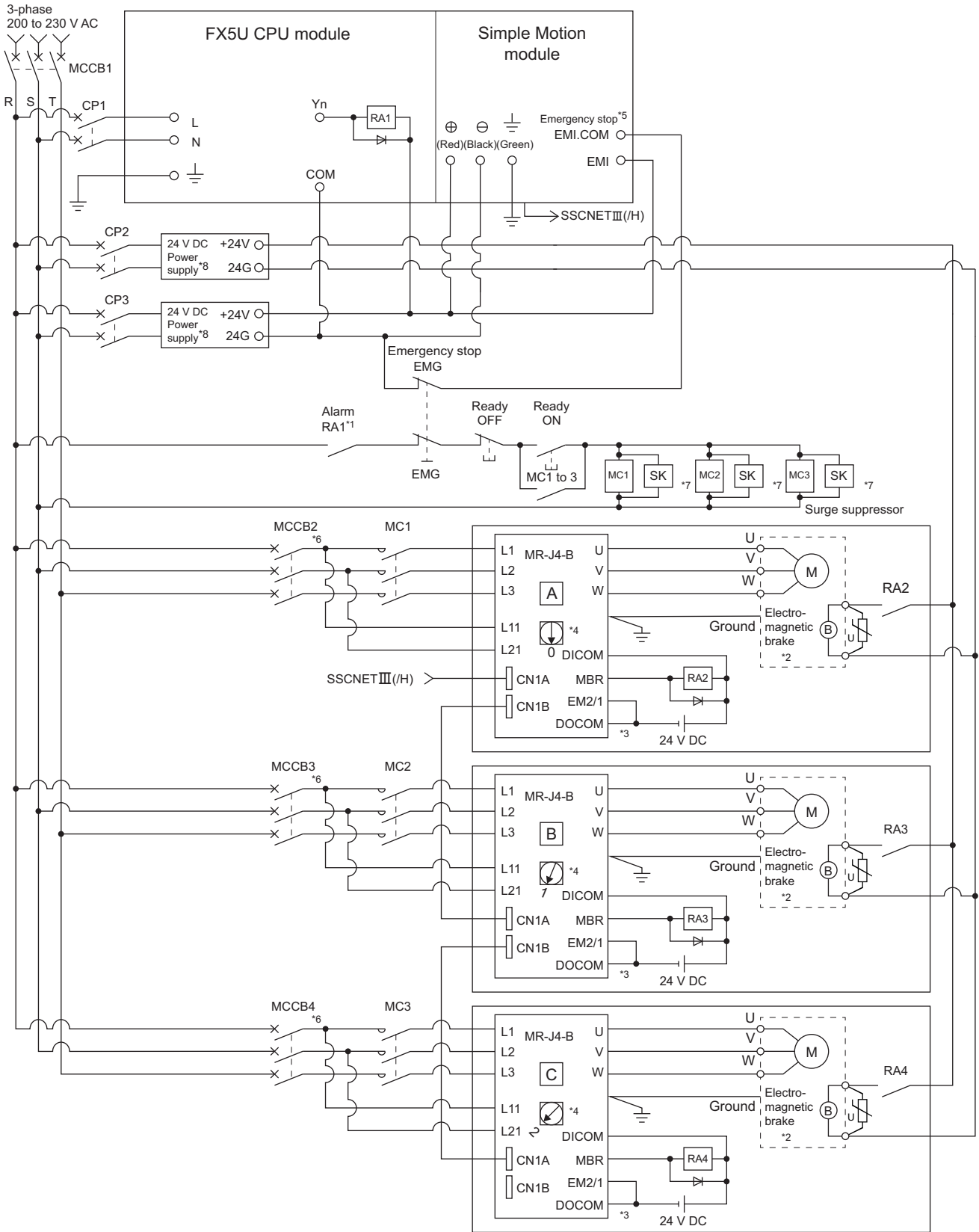

- \*1 Configure up the power supply circuit which switches off the electromagnetic contactor (MC) after detecting the alarm occurrence on the CPU module.
- \*2 It is also possible to use a full wave rectified power supply as the power supply for the electromagnetic brake.
- \*3 It is also possible to perform the forced stop using a forced stop terminal of the servo amplifier.
- \*4 Set the axis selection rotary switch of servo amplifier as follows to set the axis No. of servo amplifier.
  - Axis 1: 0, Axis 2: 1, Axis 3: 2, Axis 4: 3
- \*5 The status of forced stop input signal can be confirmed with "[Md.50] Forced stop input". Be sure that the forced stop 24 V DC power supply is not used with the electromagnetic brake of the motor or the electromagnetic valve power supply.
- \*6 Refer to the servo amplifier instruction manual for selection of the circuit breaker and electromagnetic contactor.
- \*7 The surge suppressor is recommended to be used for an AC relay or electromagnetic contactor (MC) near the servo amplifier. Refer to the servo amplifier instruction manual for selection of the surge suppressor.
- \*8 Wire the electromagnetic brake power supply and the control power supply using a separate power supply.

## Precautions

- Be sure to shut off both of main circuit power supply L1/L2/L3 and control power supply L11/L21 after disconnection of SSCNET communication by the connect/disconnect function of SSCNET communication at the time of exchange of servo amplifier. At this time, it is not possible to communicate between the servo amplifier and Simple Motion module. Therefore, be sure to exchange the servo amplifier after stopping the operating of machine beforehand.
- If the emergency stop signal of the Simple Motion module turns OFF when setting "[Pr.82] Forced stop valid/invalid selection" to "0: Valid (External input signal)", servo motor is stopped by dynamic brake. (The LED display of servo amplifier indicates "E7.1" (Controller forced stop input warning).)
- When the control power supply of servo amplifier is shut off, it is not possible to communicate with the servo amplifier after that.

### Ex.

When the control power supply L11/L21 of the servo amplifier B in the above figure is shut off, it is also not possible to communicate with the servo amplifier C.

If only a specific servo amplifier main circuit power supply is shut off, be sure to shut off the main circuit power supply L1/L2/L3, and do not shut off the control power supply L11/L21.

## Example when using the forced stop of the Simple Motion module (For MR-JE-B(F))



- The hot line forced stop function is enabled at the MR-JE-B(F) factory-set. (Only MR-JE-B(F))
- This function is used to execute deceleration stop for all axes by outputting the hot line forced stop signal to all axes and generating "E7.1" (Controller forced stop input warning) at the alarm occurrence.
- This function can be disabled by the servo parameter (PA27).
- For using the MR-JE-B(F), configure up the power supply circuit which switches off the all axes electromagnetic contactor (MC) from the CPU module after detecting the alarm occurrence on the CPU module.

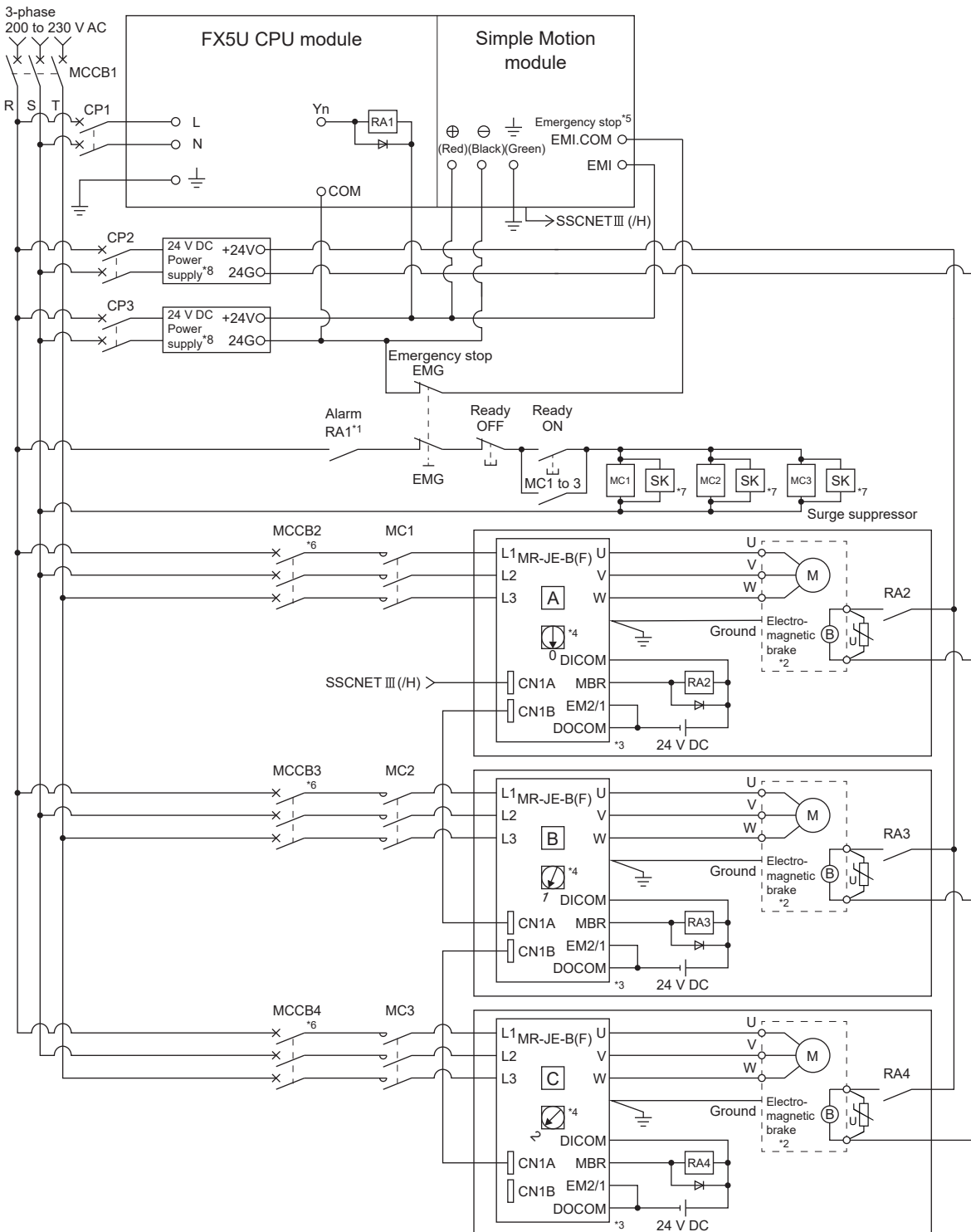

- \*1 Configure up the power supply circuit which switches off the electromagnetic contactor (MC) after detecting the alarm occurrence on the CPU module.
- \*2 It is also possible to use a full wave rectified power supply as the power supply for the electromagnetic brake.
- \*3 It is also possible to perform the forced stop using a forced stop terminal of the servo amplifier.
- \*4 Set the axis selection rotary switch of servo amplifier as follows to set the axis No. of servo amplifier.
  - Axis 1: 0, Axis 2: 1, Axis 3: 2, Axis 4: 3
- \*5 The status of forced stop input signal can be confirmed with "[Md.50] Forced stop input". Be sure that the forced stop 24 V DC power supply is not used with the electromagnetic brake of the motor or the electromagnetic valve power supply.
- \*6 Refer to the servo amplifier instruction manual for selection of the circuit breaker and electromagnetic contactor.
- \*7 The surge suppressor is recommended to be used for an AC relay or electromagnetic contactor (MC) near the servo amplifier. Refer to the servo amplifier instruction manual for selection of the surge suppressor.
- \*8 Wire the electromagnetic brake power supply and the control power supply using a separate power supply.

## Precautions

- Be sure to shut off power supply L1/L2/L3 at the time of exchange of servo amplifier. At this time, it is not possible to communicate between the servo amplifier and Simple Motion module. Therefore, be sure to exchange the servo amplifier after stopping the operating of machine beforehand.
- If the emergency stop signal of the Simple Motion module turns OFF when setting "[Pr.82] Forced stop valid/invalid selection" to "0: Valid (External input signal)", servo motor is stopped by dynamic brake. (The LED display of servo amplifier indicates "E7.1" (Controller forced stop input warning).)
- When the power supply of servo amplifier is shut off, it is not possible to communicate with the servo amplifier after that.

### Ex.

When the power supply L1/L2/L3 of the servo amplifier B in the above figure is shut off, it is also not possible to communicate with the servo amplifier C.

## Example when using the forced stop of the Simple Motion module and MR-JE-B(F)



- The hot line forced stop function is enabled at the MR-JE-B(F) factory-set. (Only MR-JE-B(F))
- This function is used to execute deceleration stop for all axes by outputting the hot line forced stop signal to all axes and generating "E7.1" (Controller forced stop input warning) at the alarm occurrence.
- This function can be disabled by the servo parameter (PA27).
- For using the MR-JE-B(F), configure up the power supply circuit which switches off the all axes electromagnetic contactor (MC) from the CPU module after detecting the alarm occurrence on the CPU module.

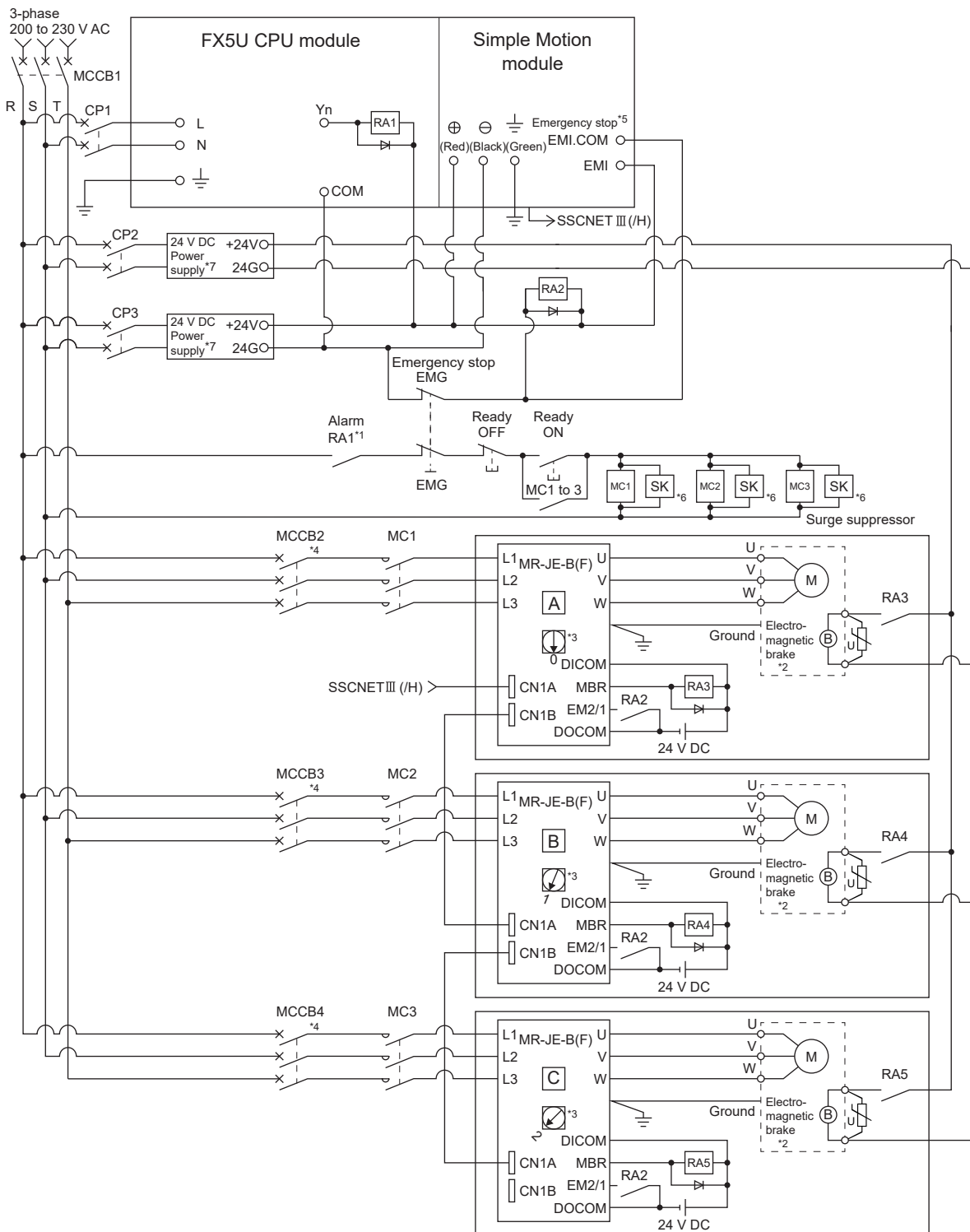

- \*1 Configure up the power supply circuit which switches off the electromagnetic contactor (MC) after detecting the alarm occurrence on the CPU module.
- \*2 It is also possible to use a full wave rectified power supply as the power supply for the electromagnetic brake.
- \*3 Set the axis selection rotary switch of servo amplifier as follows to set the axis No. of servo amplifier.
  - Axis 1: 0, Axis 2: 1, Axis 3: 2, Axis 4: 3
- \*4 Refer to the servo amplifier instruction manual for selection of the circuit breaker and electromagnetic contactor.
- \*5 The status of forced stop input signal can be confirmed with "[Md.50] Forced stop input". Be sure that the forced stop 24 V DC power supply is not used with the electromagnetic brake of the motor or the electromagnetic valve power supply.
- \*6 The surge suppressor is recommended to be used for an AC relay or electromagnetic contactor (MC) near the servo amplifier. Refer to the servo amplifier instruction manual for selection of the surge suppressor.
- \*7 Wire the electromagnetic brake power supply and the control power supply using a separate power supply.

## Precautions

- Be sure to shut off power supply L1/L2/L3 at the time of exchange of servo amplifier. At this time, it is not possible to communicate between the servo amplifier and Simple Motion module. Therefore, be sure to exchange the servo amplifier after stopping the operating of machine beforehand.
- The dynamic brake operates and servo motor occurs to the free run when EM1 (forced stop) of the servo amplifier is turned OFF. At the time, the display shows "E6.1" (Forced stop warning). During ordinary operation, do not use EM1 (forced stop) of the servo amplifier to alternate stop and run. The service life of the servo amplifier may be shortened.
- When the power supply of servo amplifier is shut off, it is not possible to communicate with the servo amplifier after that.

### Ex.

When the power supply L1/L2/L3 of the servo amplifier B in the above figure is shut off, it is also not possible to communicate with the servo amplifier C.

■ Example when using the forced stop of the Simple Motion module and MR-J4-B

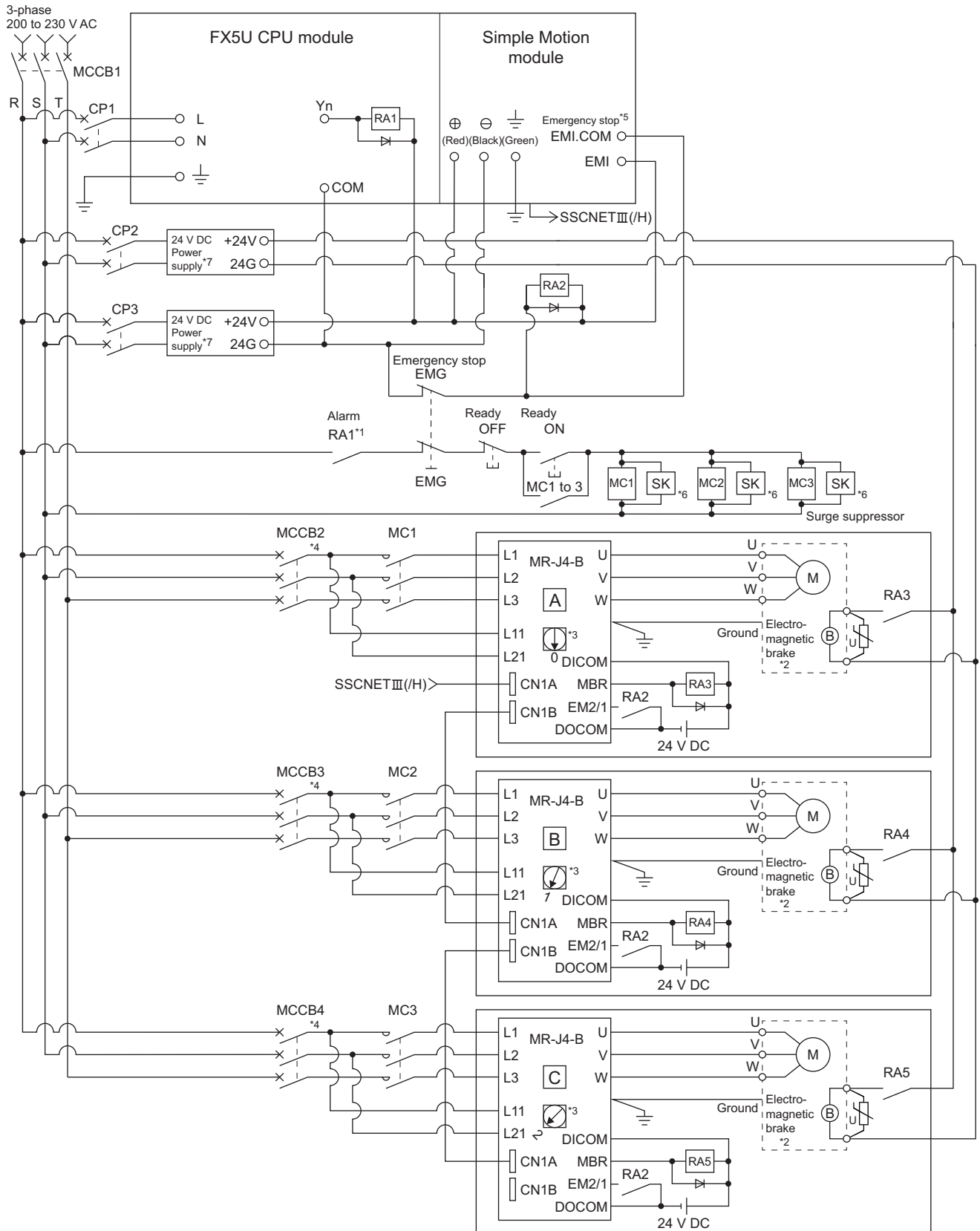

- \*1 Configure up the power supply circuit which switches off the electromagnetic contactor (MC) after detecting the alarm occurrence on the CPU module.
- \*2 It is also possible to use a full wave rectified power supply as the power supply for the electromagnetic brake.
- \*3 Set the axis selection rotary switch of servo amplifier as follows to set the axis No. of servo amplifier.  
● Axis 1: 0, Axis 2: 1, Axis 3: 2, Axis 4: 3
- \*4 Refer to the servo amplifier instruction manual for selection of the circuit breaker and electromagnetic contactor.
- \*5 The status of forced stop input signal can be confirmed with "[Md.50] Forced stop input". Be sure that the forced stop 24 V DC power supply is not used with the electromagnetic brake of the motor or the electromagnetic valve power supply.
- \*6 The surge suppressor is recommended to be used for an AC relay or electromagnetic contactor (MC) near the servo amplifier.  
Refer to the servo amplifier instruction manual for selection of the surge suppressor.
- \*7 Wire the electromagnetic brake power supply and the control power supply using a separate power supply.

## Precautions

- Be sure to shut off both of main circuit power supply L1/L2/L3 and control power supply L11/L21 after disconnection of SSCNET communication by the connect/disconnect function of SSCNET communication at the time of exchange of servo amplifier. At this time, it is not possible to communicate between the servo amplifier and Simple Motion module. Therefore, be sure to exchange the servo amplifier after stopping the operating of machine beforehand.
- The dynamic brake operates and servo motor occurs to the free run when EM1 (forced stop) of the servo amplifier is turned OFF. At the time, the display shows "E6.1" (Forced stop warning). During ordinary operation, do not use EM1 (forced stop) of the servo amplifier to alternate stop and run. The service life of the servo amplifier may be shortened.
- When the control power supply of servo amplifier is shut off, it is not possible to communicate with the servo amplifier after that.

### Ex.

When the control power supply L11/L21 of the servo amplifier B in the above figure is shut off, it is also not possible to communicate with the servo amplifier C.

If only a specific servo amplifier main circuit power supply is shut off, be sure to shut off the main circuit power supply L1/L2/L3, and do not shut off the control power supply L11/L21.

# External circuit design [FX5-SSC-G]

## Example when using the forced stop of the Motion module (For MR-J5-G)

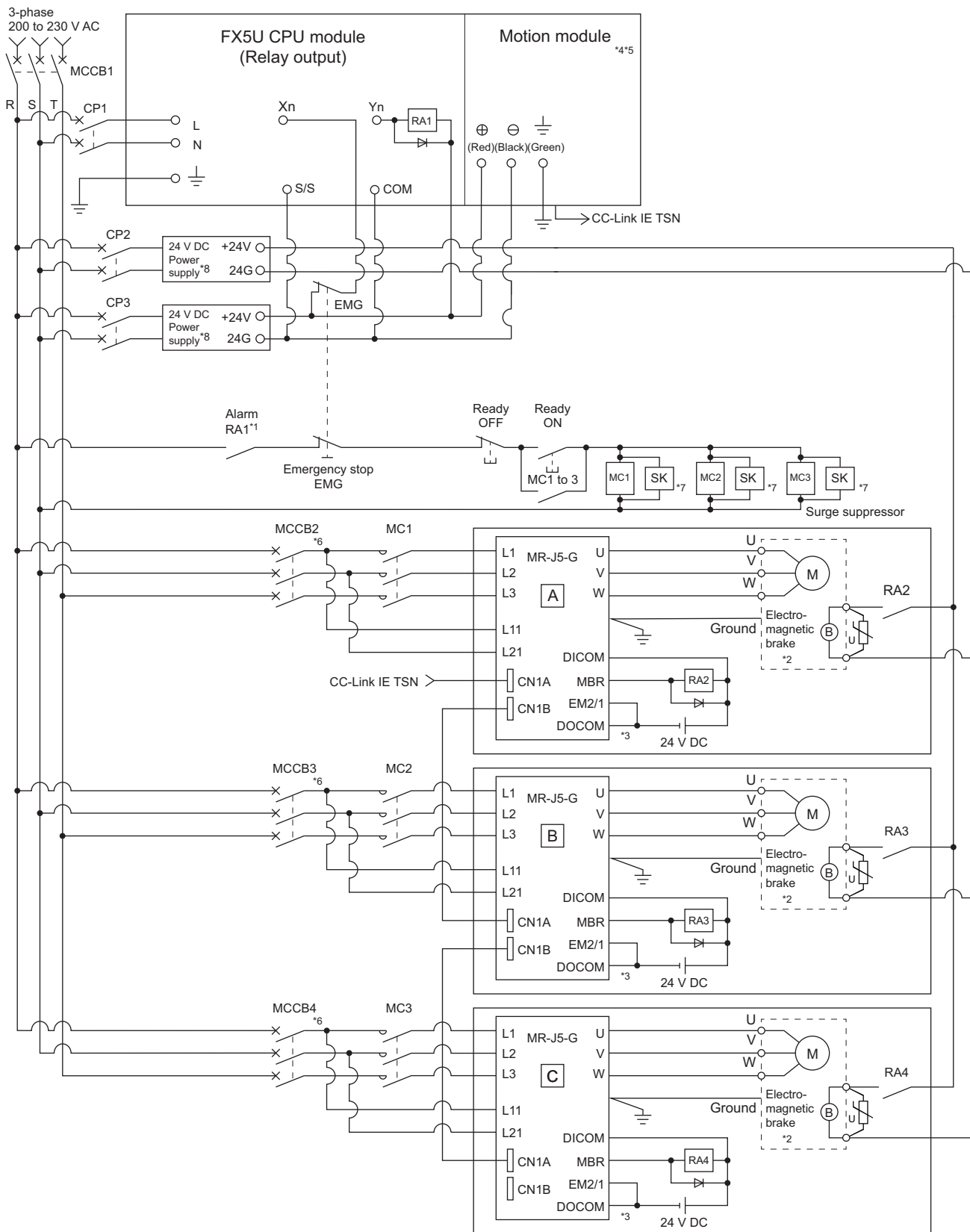

- \*1 Configure up the power supply circuit which switches off the electromagnetic contactor (MC) after detecting the alarm occurrence on the CPU module.
- \*2 It is also possible to use a full wave rectified power supply as the power supply for the electromagnetic brake.
- \*3 It is also possible to perform the forced stop using a forced stop terminal of the servo amplifier.
- \*4 It is also possible to perform the forced stop using the emergency stop function of the Motion module.  
For details, refer to "Functions to Limit the Control" in the following manual.  
  - 📖 MELSEC iQ-F FX5 Motion Module/Simple Motion Module User's Manual (Application)
- \*5 The status of forced stop input signal can be confirmed with "[Md.50] Forced stop input".
- \*6 Refer to the servo amplifier manual for selection of the circuit breaker and electromagnetic contactor.
- \*7 The surge suppressor is recommended to be used for an AC relay or electromagnetic contactor (MC) near the servo amplifier.  
Refer to the servo amplifier manual for selection of the surge suppressor.
- \*8 Wire the electromagnetic brake power supply and the control power supply using a separate power supply.

## Precautions

- Be sure to shut off both of main circuit power supply L1/L2/L3 and control power supply L11/L21 at the time of exchange of servo amplifier. At this time, it is not possible to communicate between the servo amplifier and Simple Motion module.  
Therefore, be sure to exchange the servo amplifier after stopping the operating of machine beforehand.
- If the emergency stop signal of the Motion module turns OFF when setting "[Pr.82] Forced stop valid/invalid selection" to "0: Valid (Buffer memory)", servo motor is stopped by dynamic brake.
- When the control power supply of servo amplifier is shut off, it is not possible to communicate with the servo amplifier after that.

### Ex.

When the control power supply L11/L21 of the servo amplifier B in the above figure is shut off, it is also not possible to communicate with the servo amplifier C.

If only a specific servo amplifier main circuit power supply is shut off, be sure to shut off the main circuit power supply L1/L2/L3, and do not shut off the control power supply L11/L21.

## ■ Example when using the forced stop of the Motion module (For MR-JET-G)

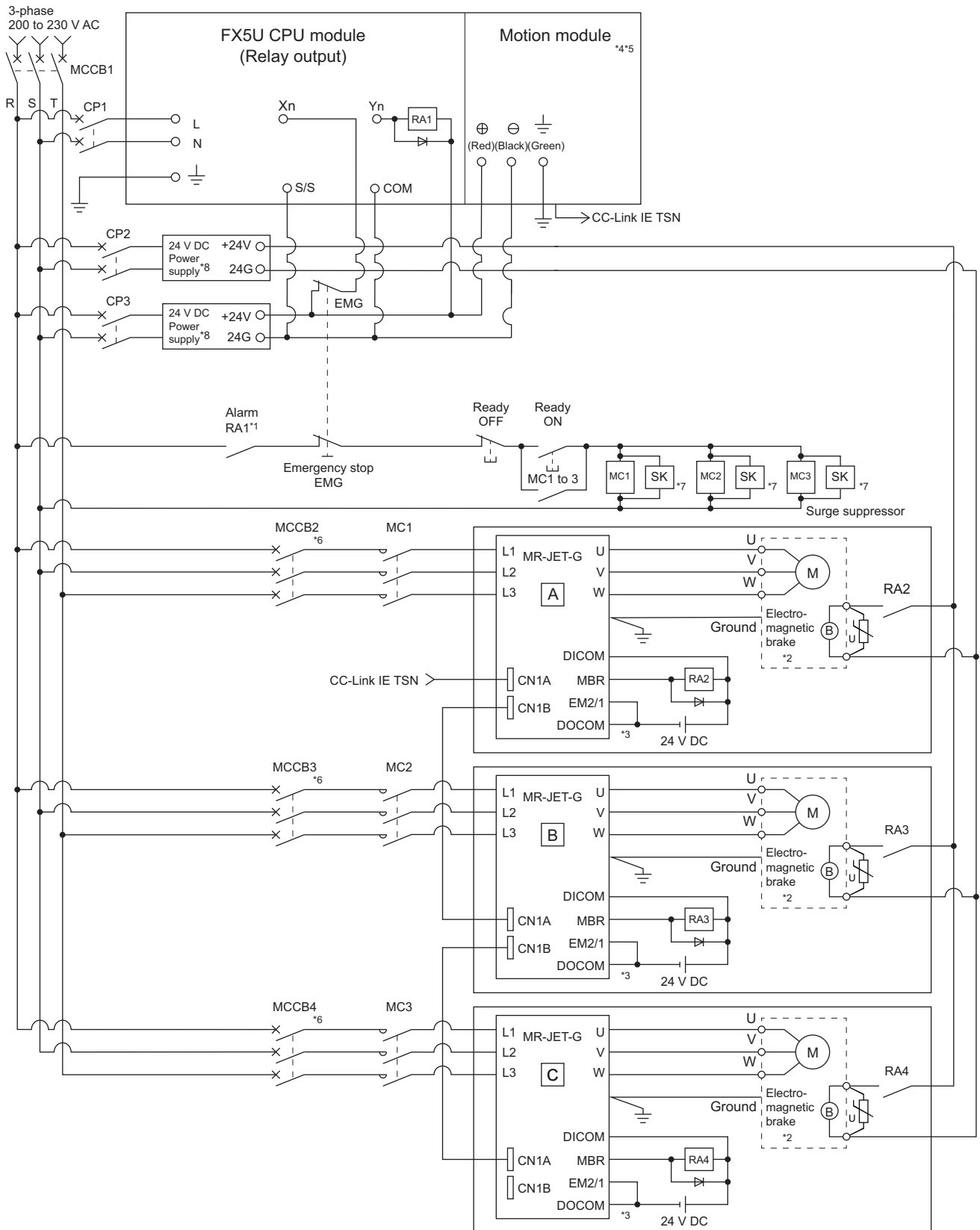

- \*1 Configure up the power supply circuit which switches off the electromagnetic contactor (MC) after detecting the alarm occurrence on the CPU module.
- \*2 It is also possible to use a full wave rectified power supply as the power supply for the electromagnetic brake.
- \*3 It is also possible to perform the forced stop using a forced stop terminal of the servo amplifier.
- \*4 It is also possible to perform the forced stop using the emergency stop function of the Motion module.  
For details, refer to "Functions to Limit the Control" in the following manual.  
📖 MELSEC iQ-F FX5 Motion Module/Simple Motion Module User's Manual (Application)
- \*5 The status of forced stop input signal can be confirmed with "[Md.50] Forced stop input".
- \*6 Refer to the servo amplifier instruction manual for selection of the circuit breaker and electromagnetic contactor.
- \*7 The surge suppressor is recommended to be used for an AC relay or electromagnetic contactor (MC) near the servo amplifier.  
Refer to the servo amplifier instruction manual for selection of the surge suppressor.
- \*8 Wire the electromagnetic brake power supply and the control power supply using a separate power supply.

## Precautions

- Be sure to shut off power supply L1/L2/L3 at the time of exchange of servo amplifier. At this time, it is not possible to communicate between the servo amplifier and Simple Motion module. Therefore, be sure to exchange the servo amplifier after stopping the operating of machine beforehand.
- If the emergency stop signal of the Motion module turns OFF when setting "[Pr.82] Forced stop valid/invalid selection" to "0: Valid (Buffer memory)", servo motor is stopped by dynamic brake.
- When the power supply of servo amplifier is shut off, it is not possible to communicate with the servo amplifier after that.

### Ex.

When the power supply L1/L2/L3 of the servo amplifier B in the above figure is shut off, it is also not possible to communicate with the servo amplifier C.

## ■ Example when using the forced stop of the Motion module and MR-J5-G

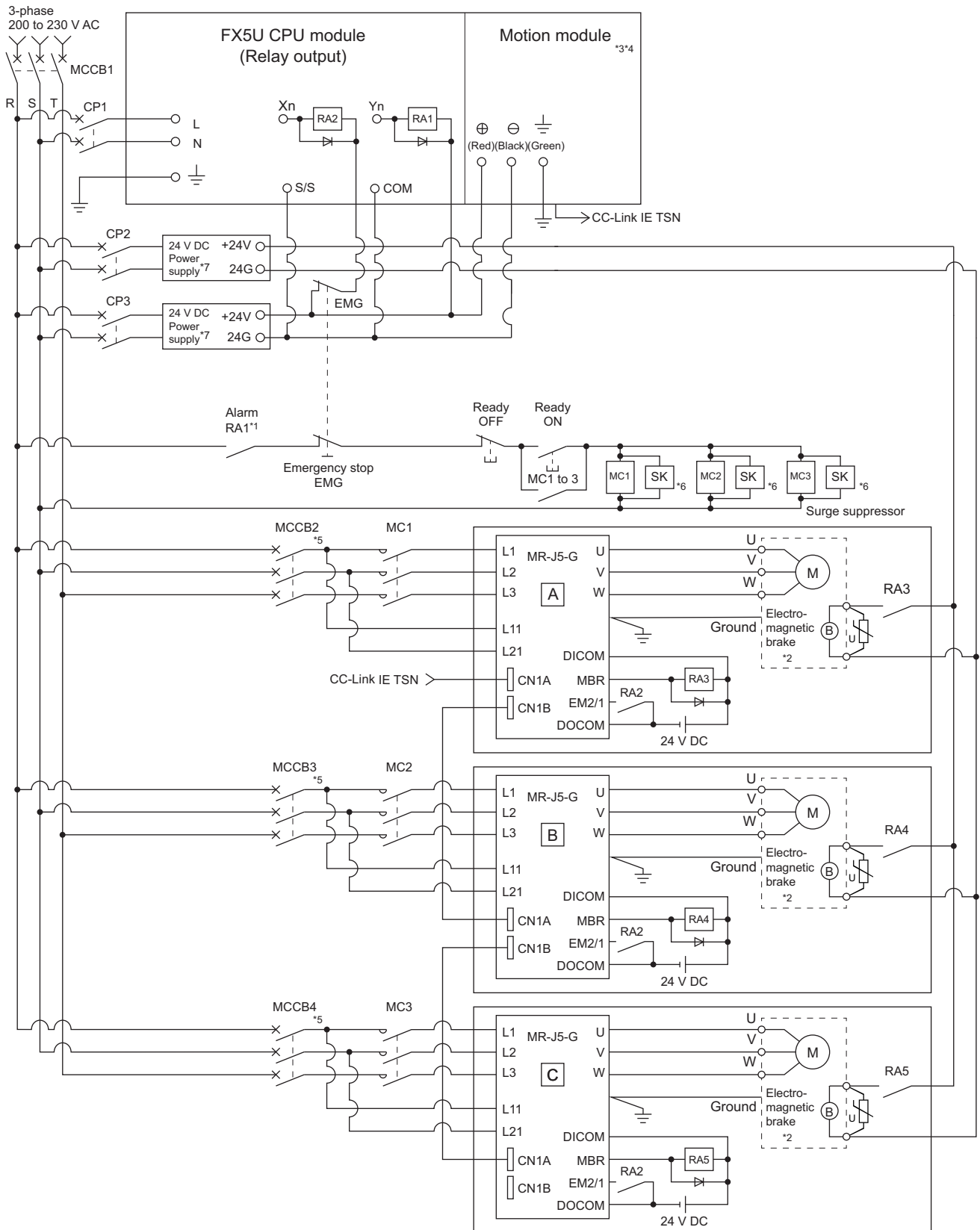

- \*1 Configure up the power supply circuit which switches off the electromagnetic contactor (MC) after detecting the alarm occurrence on the CPU module.
- \*2 It is also possible to use a full wave rectified power supply as the power supply for the electromagnetic brake.
- \*3 It is also possible to perform the forced stop using the emergency stop function of the Motion module.  
For details, refer to "Functions to Limit the Control" in the following manual.  
📖 MELSEC iQ-F FX5 Motion Module/Simple Motion Module User's Manual (Application)
- \*4 The status of forced stop input signal can be confirmed with "[Md.50] Forced stop input". Be sure that the forced stop 24 V DC power supply is not used with the electromagnetic brake of the motor or the electromagnetic valve power supply.
- \*5 Refer to the servo amplifier manual for selection of the circuit breaker and electromagnetic contactor.
- \*6 The surge suppressor is recommended to be used for an AC relay or electromagnetic contactor (MC) near the servo amplifier.  
Refer to the servo amplifier manual for selection of the surge suppressor.
- \*7 Wire the electromagnetic brake power supply and the control power supply using a separate power supply.

## Precautions

- Be sure to shut off both of main circuit power supply L1/L2/L3 and control power supply L11/L21 at the time of exchange of servo amplifier. At this time, it is not possible to communicate between the servo amplifier and Simple Motion module.  
Therefore, be sure to exchange the servo amplifier after stopping the operating of machine beforehand.
- The dynamic brake operates and servo motor occurs to the free run when EM1 (forced stop) of the servo amplifier is turned OFF. At the time, the display shows "0E6.1" (Forced stop warning). During ordinary operation, do not use EM1 (forced stop) of the servo amplifier to alternate stop and run. The service life of the servo amplifier may be shortened.
- When the control power supply of servo amplifier is shut off, it is not possible to communicate with the servo amplifier after that.

### Ex.

When the control power supply L11/L21 of the servo amplifier B in the above figure is shut off, it is also not possible to communicate with the servo amplifier C.

If only a specific servo amplifier main circuit power supply is shut off, be sure to shut off the main circuit power supply L1/L2/L3, and do not shut off the control power supply L11/L21.

## Example when using the forced stop of the Motion module and MR-JET-G

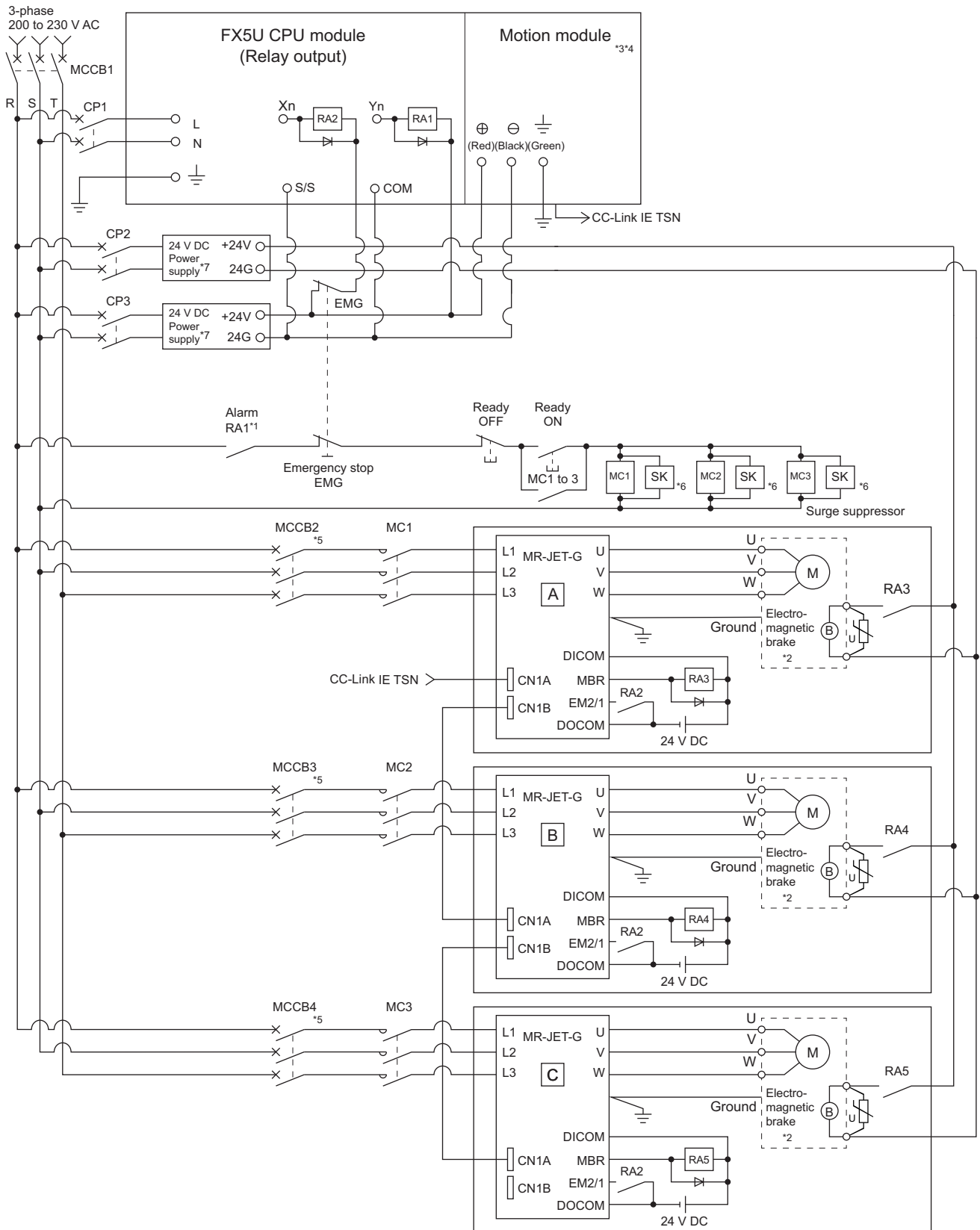

- \*1 Configure up the power supply circuit which switches off the electromagnetic contactor (MC) after detecting the alarm occurrence on the CPU module.
- \*2 It is also possible to use a full wave rectified power supply as the power supply for the electromagnetic brake.
- \*3 It is also possible to perform the forced stop using the emergency stop function of the Motion module.  
For details, refer to "Functions to Limit the Control" in the following manual.  
📖 MELSEC iQ-F FX5 Motion Module/Simple Motion Module User's Manual (Application)
- \*4 The status of forced stop input signal can be confirmed with "[Md.50] Forced stop input". Be sure that the forced stop 24 V DC power supply is not used with the electromagnetic brake of the motor or the electromagnetic valve power supply.
- \*5 Refer to the servo amplifier instruction manual for selection of the circuit breaker and electromagnetic contactor.
- \*6 The surge suppressor is recommended to be used for an AC relay or electromagnetic contactor (MC) near the servo amplifier.  
Refer to the servo amplifier instruction manual for selection of the surge suppressor.
- \*7 Wire the electromagnetic brake power supply and the control power supply using a separate power supply.

## Precautions

- Be sure to shut off power supply L1/L2/L3 at the time of exchange of servo amplifier. At this time, it is not possible to communicate between the servo amplifier and Simple Motion module. Therefore, be sure to exchange the servo amplifier after stopping the operating of machine beforehand.
- The dynamic brake operates and servo motor occurs to the free run when EM1 (forced stop) of the servo amplifier is turned OFF. At the time, the display shows "0E6.1" (Forced stop warning). During ordinary operation, do not use EM1 (forced stop) of the servo amplifier to alternate stop and run. The service life of the servo amplifier may be shortened.
- When the power supply of servo amplifier is shut off, it is not possible to communicate with the servo amplifier after that.

### Ex.

When the power supply L1/L2/L3 of the servo amplifier B in the above figure is shut off, it is also not possible to communicate with the servo amplifier C.

# 3 FUNCTION LIST

The functions that can be used are restricted depending on the version of the Simple Motion module/Motion module software and engineering tool. For details, refer to "Restrictions by the version" in the following manual.

📖 MELSEC iQ-F FX5 Motion Module/Simple Motion Module User's Manual (Application)

## 3.1 Control Functions

The Simple Motion module/Motion module has several functions. Refer to the following manual for details on each function.

📖 MELSEC iQ-F FX5 Motion Module/Simple Motion Module User's Manual (Application)

In this manual, the Simple Motion module/Motion module functions are categorized and explained as follows.

### Main functions

#### Home position return control

"Home position return control" is a function (Fast home position return) that established the start point for carrying out positioning control (Machine home position return), and carries out positioning toward that start point. This is used to return a workpiece, located at a position other than the home position when the power is turned ON or after positioning stop, to the home position. The "home position return control" is pre-registered in the Simple Motion module/Motion module as the "Positioning start data No. 9001 (Machine home position return)", and "Positioning start data No. 9002 (Fast home position return)".

#### Major positioning control

This control is carried out using the "Positioning data" stored in the Simple Motion module/Motion module. Positioning control, such as position control and speed control, is executed by setting the required items in this "positioning data" and starting that positioning data. An "operation pattern" can be set in this "positioning data", and with this whether to carry out control with continuous positioning data (ex.: positioning data No. 1, No. 2, No. 3, etc.) can be set.

#### High-level positioning control

This control executes the "positioning data" stored in the Simple Motion module/Motion module using the "block start data". Applied types of positioning control can be carried out as shown below.

- Random blocks, handling several continuing positioning data items as "blocks", can be executed in the designated order.
- "Condition judgment" can be added to position control and speed control.
- The operation of the positioning data that is set for multiple axes can be started simultaneously. (Command is output simultaneously to multiple servo amplifiers.)
- The designated positioning data can be executed repeatedly.

#### Manual control

The Simple Motion module/Motion module executes the random positioning operation by inputting a signal into the Simple Motion module/Motion module from an external device.

Use this manual control to move the workpiece to a random position (JOG operation), and to finely adjust the positioning (inching operation, manual pulse generator operation), etc.

#### Expansion control

The following controls other than the positioning control can be executed.

- Speed control and torque control not including position loop for the command to servo amplifier (Speed-torque control).
- Synchronous control that uses "advanced synchronous control parameter" to synchronize with the input axis using software instead of using a mechanical configuration consisting of a gear, shaft, change gear, and cam. (Advanced synchronous control).

The outline of the main functions for positioning control with the Simple Motion module/Motion module is described below.

Main functions		Details	
Home position return control	Machine home position return control	Mechanically establishes the positioning start point using a proximity dog, etc. In the data setting method, no axis movement occurs since the current position is set as the home position. (Positioning start No. 9001)	
	Fast home position return control	Positions a target to the home position address ([Md.21] Machine feed value) stored in the Simple Motion module/Motion module using machine home position return. (Positioning start No. 9002)	
Major positioning control	Position control	Linear control (1-axis linear control) (2-axis linear interpolation control) (3-axis linear interpolation control) (4-axis linear interpolation control)	Positions a target using a linear path to the address set in the positioning data or to the position designated with the movement amount.
		Fixed-feed control (1-axis fixed-feed control) (2-axis fixed-feed control) (3-axis fixed-feed control) (4-axis fixed-feed control)	Positions a target by the movement amount designated with the amount set in the positioning data. (With fixed-feed control, the "[Md.20] Command position value" is set to "0" when the control is started. With 2-, 3-, or 4-axis fixed-feed control, the fixed-feed is fed along a linear path obtained by interpolation.)
		2-axis circular interpolation control	Positions a target using an arc path to the address set in the positioning data, or to the position designated with the movement amount, sub point or center point.
	Speed control	Speed control (1-axis speed control) (2-axis speed control) (3-axis speed control) (4-axis speed control)	Continuously outputs the command corresponding to the command speed set in the positioning data.
		Speed-position switching control	First, carries out speed control, and then carries out position control (positioning with designated address or movement amount) by turning the "speed-position switching signal" ON.
	Position-speed switching control	First, carries out position control, and then carries out speed control (continuous output of the command corresponding to the designated command speed) by turning the "position-speed switching signal" ON.	
	Other control	Current value changing	Changes the command position value ([Md.20]) to the address set in the positioning data. The following two methods can be used. (The machine feed value ([Md.21]) cannot be changed.) • Current value changing using positioning data • Current value changing using current value changing start No. (No. 9003)
		NOP instruction	No execution control method. When NOP instruction is set, this instruction is not executed and the operation of the next data is started.
		JUMP instruction	Unconditionally or conditionally jumps to designated positioning data No.
		LOOP	Carries out loop control with repeated LOOP to LEND.
LEND		Returns to the beginning of the loop control with repeated LOOP to LEND.	
High-level positioning control	Block start (Normal start)	With one start, executes the positioning data in a random block with the set order.	
	Condition start	Carries out condition judgment set in the "condition data" for the designated positioning data, and then executes the "block start data". When the condition is established, the "block start data" is executed. When not established, that "block start data" is ignored, and the next point's "block start data" is executed.	
	Wait start	Carries out condition judgment set in the "condition data" for the designated positioning data, and then executes the "block start data". When the condition is established, the "block start data" is executed. When not established, stops the control until the condition is established. (Waits.)	
	Simultaneous start	Simultaneously executes the designated positioning data of the axis designated with the "condition data". (Outputs commands at the same timing.)	
	Repeated start (FOR loop)	Repeats the program from the block start data set with the "FOR loop" to the block start data set in "NEXT" for the designated number of times.	
	Repeated start (FOR condition)	Repeats the program from the block start data set with the "FOR condition" to the block start data set in "NEXT" until the conditions set in the "condition data" are established.	
Manual control	JOG operation	Outputs a command to servo amplifier while the JOG start signal is ON.	
	Inching operation	Outputs commands corresponding to minute movement amount by manual operation to servo amplifier. (Performs fine adjustment with the JOG start signal.)	
	Manual pulse generator operation	Outputs pulses commanded with the manual pulse generator to servo amplifier.	

Main functions		Details
Expansion control	Speed-torque control	Carries out the speed control or torque control that does not include the position loop for the command to servo amplifier by switching control mode.
	Advanced synchronous control	Carries out the synchronous control that synchronizes with the input axis by setting the system such as gear, shaft, change gear and cam to the "advanced synchronous control parameter".

In "major positioning control" ("high-level positioning control"), "Operation pattern" can be set to designate whether to continue executing positioning data. Outlines of the "operation patterns" are given below.

[Da.1] Operation pattern	Details
Independent positioning control (positioning complete)	When "independent positioning control" is set for the operation pattern of the started positioning data, only the designated positioning data will be executed, and then the positioning will end.
Continuous positioning control	When "continuous positioning control" is set for the operation pattern of the started positioning data, after the designated positioning data is executed, the program will stop once, and then the next following positioning data will be executed.
Continuous path control	When "continuous path control" is set for the operation pattern of the started positioning data, the designated positioning data will be executed, and then without decelerating, the next following positioning data will be executed.

# Sub functions

When the main functions are executed, this function compensates and limits controls, or adds functions.

The outline of the functions that assist positioning control using the Simple Motion module/Motion module is described below.

Sub function	Details	
Functions characteristic to machine home position return	Home position return retry function [FX5-SSC-S]	This function retries the home position return with the upper/lower limit switches during the machine home position return. This allows machine home position return to be carried out even if the axis is not returned to before the proximity dog with JOG operation, etc.
	Home position shift function [FX5-SSC-S]	After returning to the machine home position, this function compensates the position by the designated distance from the machine home position and sets that position as the home position address.
Functions that compensate control	Backlash compensation function	This function compensates the mechanical backlash amount. Feed commands equivalent to the set backlash amount are output each time the movement direction changes.
	Electronic gear function	By setting the movement amount per pulse, this function can freely change the machine movement amount per commanded pulse. When the movement amount per pulse is set, a flexible positioning system that matches the machine system can be structured.
	Near pass function *1	This function suppresses the machine vibration when the speed is changed during continuous path control in the interpolation control.
Functions that limit control	Speed limit function	If the command speed exceeds "[Pr.8] Speed limit value" during control, this function limits the commanded speed to within the "[Pr.8] Speed limit value" setting range.
	Torque limit function	If the torque generated by the servo motor exceeds "[Pr.17] Torque limit setting value" during control, this function limits the generated torque to within the "[Pr.17] Torque limit setting value" setting range.
	Software stroke limit function	If a command outside of the upper/lower limit stroke limit setting range, set in the parameters, is issued, this function will not execute positioning for that command.
	Hardware stroke limit function	This function carries out deceleration stop with the hardware stroke limit switch.
	Forced stop function	This function stops all axes of the servo amplifier with the forced stop signal.
Functions that change control details	Speed change function	This function changes the speed during positioning. Set the new speed in the speed change buffer memory ([Cd.14] New speed value), and change the speed with the speed change request ([Cd.15]).
	Override function	This function changes the speed by a designated percentage during positioning. This is executed using "[Cd.13] Positioning operation speed override".
	Acceleration/deceleration time change function	This function changes the acceleration/deceleration time during speed change.
	Torque change function	This function changes the "torque limit value" during control.
	Target position change function	This function changes the target position during positioning. Position and speed can be changed simultaneously.
Functions related to positioning start	Pre-reading start function	This function shortens the virtual start time.
Absolute position system		This function restores the absolute position of designated axis.
Functions related to positioning stop	Stop command processing for deceleration stop function	Function that selects a deceleration curve when a stop cause occurs during deceleration stop processing to speed 0.
	Continuous operation interrupt function	This function interrupts continuous operation. When this request is accepted, the operation stops when the execution of the current positioning data is completed.
	Step function	This function temporarily stops the operation to confirm the positioning operation during debugging, etc. The operation can be stopped at each "automatic deceleration" or "positioning data".
Other functions	Skip function	This function stops (decelerates to a stop) the positioning being executed when the skip signal is input, and carries out the next positioning.
	M code output function	This function issues a command for a sub work (clamp or drill stop, tool change, etc.) according to the code No. (0 to 65535) that can be set for each positioning data.
	Teaching function	This function stores the address positioned with manual control into the "[Da.6] Positioning address/movement amount" having the designated positioning data No. ([Cd.39]).
	Command in-position function	This function calculates the remaining distance for the Simple Motion module/Motion module to reach the positioning stop position. When the value is less than the set value, the "command in-position flag" is set to "1". When using another auxiliary work before ending the control, use this function as a trigger for the sub work.
	Acceleration/deceleration processing function	This function adjusts the acceleration/deceleration.

Sub function		Details
Other functions	Deceleration start flag function	Function that turns ON the flag when the constant speed status or acceleration status switches to the deceleration status during position control, whose operation pattern is "Positioning complete", to make the stop timing known.
	Speed control 10 times multiplier setting for degree axis function	This function executes the positioning control by the 10 times speed of the command speed and the speed limit value when the setting unit is "degree".
	Operation setting for incompleteness of home position return function	This function is provided to select whether positioning control is operated or not, when the home position return request flag is ON.
Servo ON/OFF	Servo ON/OFF	This function executes servo ON/OFF for the servo amplifier connected to the Simple Motion module/Motion module.
	Follow up function	This function monitors the motor rotation amount with the servo turned OFF, and reflects it on the command position value.

\*1 The near pass function is featured as standard and is valid only for setting continuous path control for position control. It cannot be set to be invalid with parameters.

# Common functions

Common control using the Simple Motion module/Motion module for "Parameter initialization function" or "Execution data backup function" can be carried out.

The outline of the functions executed as necessary is described below.

Common functions	Details
Parameter initialization function	This function returns the setting data stored in the buffer memory/internal memory and flash ROM/internal memory (nonvolatile) of Simple Motion module/Motion module to the default values. The following two methods can be used. <ul style="list-style-type: none"> <li>• Method using a program</li> <li>• Method using an engineering tool</li> </ul>
Execution data backup function	This function writes the execution data being used in the control into the flash ROM/internal memory (nonvolatile). The following two methods can be used. <ul style="list-style-type: none"> <li>• Method using a program</li> <li>• Method using an engineering tool</li> </ul>
External input signal select function	This function is used to select the following signals when using each external input signal of each axis (upper/lower stroke limit signal (FLS/RLS), proximity dog signal (DOG), and stop signal (STOP)). <ul style="list-style-type: none"> <li>• External input signal of the servo amplifier</li> <li>• External input signal via CPU (buffer memory)</li> <li>• Link device input signal [FX5-SSC-G]</li> </ul>
Link device external signal assignment function [FX5-SSC-G]	This function assigns link devices to external signals of the Simple Motion module.
History monitor function	This function monitors start history and current value history of all axes.
Amplifier-less operation function [FX5-SSC-S]	This function executes the positioning control of Simple Motion module without connecting to the servo amplifiers. It is used to debug the program at the start-up of the device or simulate the positioning operation.
Virtual servo amplifier function	This function executes the operation as the axis (virtual servo amplifier axis) that operates only command (instruction) virtually without servo amplifiers.
Driver communication function [FX5-SSC-S]	This function uses the "Master-slave operation function" of servo amplifier. The Simple Motion module controls the master axis and the slave axis is controlled by data communication between servo amplifiers (driver communication) without Simple Motion module.
Mark detection function	This function is used to latch any data at the input timing of the mark detection signal (DI).
Optional data monitor function	This function is used to store the data selected by user up to 4 data per axis to buffer memory and monitor them.
Event history function [FX5-SSC-G]	This function takes errors that occur on the Motion module and event information and collects them in the CPU module or saves them to the SD memory card. Storing the errors in the CPU allows the error history to be checked even after turning OFF the power or resetting.
Connect/disconnect function of SSCNET communication [FX5-SSC-S]	Temporarily connect/disconnect of SSCNET communication is executed during system's power supply ON. This function is used to exchange the servo amplifiers or SSCNET III cables.
Servo transient transmission function [FX5-SSC-G]	This function reads and writes objects of the device via transient transmission.
Firmware update function	This function is used to update firmware of the Simple Motion module/Motion module.
Hot line forced stop function [FX5-SSC-S]	This function is used to execute deceleration stop safety for other axes when the servo alarm occurs in the servo amplifier MR-JE-B(F).

## 3.2 Combination of Main Functions and Sub Functions

With positioning control using the Simple Motion module/Motion module, the main functions and sub functions can be combined and used as necessary. A list of the main function and sub function combinations is given below.

### Combination of main functions and operation patterns

○: Combination possible, △: Combination limited, ×: Combination not possible

Main functions		Combination with operation pattern <sup>*1</sup>	
Home position return control	Machine home position return control	×	
	Fast home position return control	×	
Major positioning control	Position control	1-axis linear control	○
		2-, 3-, or 4-axis linear interpolation control	○
		1-axis fixed-feed control	△ <sup>*2</sup>
		2-, 3-, or 4-axis fixed-feed control (interpolation)	△ <sup>*2</sup>
		2-axis circular interpolation control	○
	Speed control (1- to 4-axis)	△ <sup>*3</sup>	
	Speed-position switching control	△ <sup>*2</sup>	
	Position-speed switching control	△ <sup>*3</sup>	
	Other control	Current value changing	△ <sup>*2</sup>
		NOP instruction	×
		JUMP instruction	×
LOOP to LEND			
Manual control	JOG operation, inching operation	×	
	Manual pulse generator operation	×	
Expansion control	Speed-torque control	×	
	Advanced synchronous control (output axis)	×	

\*1 The operation pattern is one of the "positioning data" setting items.

\*2 Continuous path control cannot be set.

\*3 Only independent positioning control can be set.

## Combination of main functions and sub functions

○: Combination possible, △: Combination limited, ×: Combination not possible

Main functions		Functions that compensate control			
		Backlash compensation function	Electronic gear function	Near pass function	
Home position return control	Machine home position return control	○ [FX5-SSC-S] △*1 [FX5-SSC-G]	○ [FX5-SSC-S] △*1 [FX5-SSC-G]	△*2 [FX5-SSC-S] × [FX5-SSC-G]	
	Fast home position return control	○	○	△*2	
Major positioning control	Position control	1-axis linear control	○	○	
		2-, 3-, or 4-axis linear interpolation control	○	○	
		1-axis fixed-feed control	○	○	
		2-, 3-, or 4-axis fixed-feed control (interpolation)	○	○	
		2-axis circular interpolation control	○	○	
	Speed control (1- to 4-axis)	○	○		
	Speed-position switching control	○	○		
	Position-speed switching control				
	Other control	Current value changing	×	×	
		NOP instruction			
		JUMP instruction	×	×	
LOOP to LEND					
Manual control	JOG operation, inching operation	○	○	×	
	Manual pulse generator operation	○	○	×	
Expansion control	Speed-torque control	×	○	×	
	Advanced synchronous control (output axis)	○	○	×	

\*1 Availability of the function depends on the home position return specifications of drive units.

\*2 The near pass function is featured as standard and is valid only for setting continuous path control for position control.

◎: Always combine, ○: Combination possible, △: Combination limited, ×: Combination not possible

Main functions		Functions that limit control					
		Speed limit function	Torque limit function	Software stroke limit function	Hardware stroke limit function	Forced stop function	
Home position return control	Machine home position return control	○ [FX5-SSC-S] △*1 [FX5-SSC-G]	○ [FX5-SSC-S] △*1 [FX5-SSC-G]	× [FX5-SSC-S] △*1 [FX5-SSC-G]	◎ [FX5-SSC-S] △*1 [FX5-SSC-G]	○ [FX5-SSC-S] △*1 [FX5-SSC-G]	
	Fast home position return control	○	○	×	◎	○	
Major positioning control	Position control	1-axis linear control	○	○	○	◎	○
		2-, 3-, or 4-axis linear interpolation control	○	○	○	◎	○
		1-axis fixed-feed control	○	○	○	◎	○
		2-, 3-, or 4-axis fixed-feed control (interpolation)	○	○	○	◎	○
		2-axis circular interpolation control	○	○	○	◎	○
	Speed control (1- to 4-axis)	○	○	○	◎	○	
	Speed-position switching control	○	○	○	◎	○	
	Position-speed switching control						
	Other control	Current value changing	×	×	○ [FX5-SSC-S] × [FX5-SSC-G]	◎	○
			NOP instruction		×		
JUMP instruction		×	×	×	×	○	
LOOP to LEND							
Manual control	JOG operation, inching operation	○	○	○	◎	○	
	Manual pulse generator operation	× [FX5-SSC-S] ○ [FX5-SSC-G]	○	○	◎	○	
Expansion control	Speed-torque control	○	○	○	◎	○	
	Advanced synchronous control (output axis)	○	○	○	◎	○	

\*1 Availability of the function depends on the home position return specifications of drive units.

○: Combination possible, △: Combination limited, ×: Combination not possible

Main functions		Functions that change control details					
		Speed change function	Override function	Acceleration/ deceleration time change function	Torque change function	Target position change function	
Home position return control	Machine home position return control	△*1 [FX5-SSC-S] × [FX5-SSC-G]	△*1 [FX5-SSC-S] × [FX5-SSC-G]	△*1 [FX5-SSC-S] × [FX5-SSC-G]	○ [FX5-SSC-S] × [FX5-SSC-G]	×	
	Fast home position return control	○	○	○	○	×	
Major positioning control	Position control	1-axis linear control	○	○	○	○	△*2
		2-, 3-, or 4-axis linear interpolation control	○	○	○	○	×
		1-axis fixed-feed control	○	○	○	○	×
		2-, 3-, or 4-axis fixed-feed control (interpolation)	○	○	○	○	×
		2-axis circular interpolation control	○	○	○	○	×
	Speed control (1- to 4-axis)	○	○	○	○	×	
	Speed-position switching control	○	○	○	○	×	
	Position-speed switching control						
	Other control	Current value changing	×	×	×	×	×
		NOP instruction	×	×	×	×	×
		JUMP instruction					
LOOP to LEND							
Manual control	JOG operation, inching operation	△*3	△*3	△*3	○	×	
	Manual pulse generator operation	×	×	×	○	×	
Expansion control	Speed-torque control	×	×	×	○	×	
	Advanced synchronous control (output axis)	×	×	×	○	×	

\*1 Invalid during creep speed.

\*2 Invalid during Continuous path control.

\*3 Combination with the inching operation is not available. (Inching operation does not perform acceleration/deceleration processing.)

○: Combination possible, △: Combination limited, ×: Combination not possible

Main functions		Other functions					
		Step function	Skip function	M code output function	Teaching function	Command in-position function	
Home position return control	Machine home position return control	×	×	×	×	×	
	Fast home position return control	×	× <sup>*1</sup>	×	×	○	
Major positioning control	Position control	1-axis linear control	○	○	○	×	○
		2-, 3-, or 4-axis linear interpolation control	○	○	○	×	○
		1-axis fixed-feed control	○	○	○	×	○
		2-, 3-, or 4-axis fixed-feed control (interpolation)	○	○	○	×	○
		2-axis circular interpolation control	○	○	○	×	○
Major positioning control	Speed control (1- to 4-axis)	Speed control (1- to 4-axis)	×	×	○	×	×
		Speed-position switching control	○	○	○	×	○
		Position-speed switching control		×			
	Other control	Current value changing	○	○	△ <sup>*2</sup>	×	×
		NOP instruction	×	×	×		
		JUMP instruction	×	×	×		
LOOP to LEND							
Manual control	JOG operation, inching operation	×	×	×	○	×	
	Manual pulse generator operation	×	×	×	○	×	
Expansion control	Speed-torque control	×	×	×	×	×	
	Advanced synchronous control (output axis)	×	×	×	×	×	

\*1 [FX5-SSC-G]

Only independent positioning control can be set.

\*2 Change the current value using the positioning data. Disabled for a start of positioning start No.9003.

○: Combination possible, △: Combination limited, ×: Combination not possible

Main functions		Other functions						
		Acceleration/ deceleration processing function	Pre- reading start function	Acceleration deceleration processing function	Stop command processing for deceleration stop function	Speed control 10 times multiplier setting for degree axis function	Operation setting for incompleti on of home position return function	
Home position return control	Machine home position return control	○ [FX5-SSC-S] × [FX5-SSC-G]	×	×	○ [FX5-SSC-S] × [FX5-SSC-G]	○ [FX5-SSC-S] × [FX5-SSC-G]	×	
	Fast home position return control	○	×	×	○	○	×	
Major positioning control	Position control	1-axis linear control	○	○	○	○	○	
		2-, 3-, or 4-axis linear interpolation control	○	○	△ <sup>*1</sup>	○	○	
		1-axis fixed-feed control	○	○	○	○	○	
		2-, 3-, or 4-axis fixed-feed control (interpolation)	○	○	△ <sup>*1</sup>	○	○	
		2-axis circular interpolation control	○	○	×	○	×	
	Speed control (1- to 4-axis)	○	○	×	○	○		
	Speed-position switching control	○	○	△ <sup>*2</sup>	○	○		
	Position-speed switching control							
	Other control	Current value changing	×	×	×	×	×	△ <sup>*3</sup>
		NOP instruction						×
JUMP instruction		×	×	×	×	×	×	
LOOP to LEND								
Manual control	JOG operation, inching operation	△ <sup>*4</sup>	×	×	×	○	×	
	Manual pulse generator operation	×	×	×	×	△ <sup>*5</sup>	×	
Expansion control	Speed-torque control	△ <sup>*6</sup>	×	×	×	○	○	
	Advanced synchronous control (output axis)	△ <sup>*7</sup>	×	×	×	△ <sup>*7</sup>	○	

\*1 Valid for the reference axis only.

\*2 Valid for only the case where a deceleration start is made during position control.

\*3 Valid for a start of positioning start No.9003, but invalid for a start of positioning data (No. 1 to 600).

\*4 Combination with the inching operation is not available. (Inching operation does not perform acceleration/deceleration processing.)

\*5 Valid for "[Md.22] Speed command" and "[Md.28] Axis speed command".

\*6 Refer to "Speed-torque Control" in the following manual for acceleration/deceleration processing in the speed-torque control.

📖 MELSEC iQ-F FX5 Motion Module/Simple Motion Module User's Manual (Application)

\*7 For details, refer to "Output Axis Sub Functions" in the following manual.

📖 MELSEC iQ-F FX5 Motion Module/Simple Motion Module User's Manual (Advanced Synchronous Control)

## 3.3 Network Function List [FX5-SSC-G]

---

For CC-Link IE TSN functions, refer to "Function List" in the following manual.

 MELSEC iQ-F FX5 Motion Module User's Manual (CC-Link IE TSN)

# 4 PROCEDURES BEFORE OPERATIONS

## Settings and procedures before operation [FX5-SSC-S]

The following describes the procedures before operation of FX5-SSC-S.

### 1. Mounting the module

Mount the Simple Motion module to the CPU module.

For details, refer to the following.

📖 MELSEC iQ-F FX5S/FX5UJ/FX5U/FX5UC User's Manual (Hardware)

### 2. Wiring

Connect the Simple Motion module to external devices.

### 3. Adding the module

Add the FX5-SSC-S to the module map of the project using an engineering tool.

### 4. Module setting

Set values for the module setting using an engineering tool.

For details, refer to the following.

📖 GX Works3 Operating Manual

### 5. Auto refresh setting

Set values for the refresh settings using an engineering tool.

For details, refer to the following.

📖 GX Works3 Operating Manual

### 6. Checking connection

Check that the Simple Motion module is connected to external devices correctly.

### 7. Programming

Create programs.

For details, refer to "PROGRAMMING [FX5-SSC-S]" in the following manual.

📖 MELSEC iQ-F FX5 Motion Module/Simple Motion Module User's Manual (Application)

### 8. Test operation

Confirm that the created programs are able to execute properly.

## Settings and procedures before operation [FX5-SSC-G]

The following describes the procedures before operation of FX5-SSC-G.

For a setting example, refer to the following.

 Page 110 Setting Example for Motion Modules [FX5-SSC-G]

### 1. Mounting the module

Mount the Motion module.

### 2. Wiring

Connect the Motion module to external devices.

### 3. Adding the module

Add the FX5-SSC-G to the module map of the project using an engineering tool.

### 4. Network configuration

Set values for the network related settings in "Module Parameter (Network)" of the engineering tool.

- Set the communication cycle used for the network configuration settings.

Set the basic communication cycle according to the number of control axes and the network device configuration. Use the communication cycle as a reference for the cycle. For details, refer to "Processing Time" in the following manual.

 MELSEC iQ-F FX5 Motion Module User's Manual (CC-Link IE TSN)

- Set the device station in network configuration settings.

The slave stations that are to be controlled with the Motion module must be set to "Motion Control Station". When setting device stations to "Motion Control Station", set the communication cycle to the basic cycle.

For details, refer to "Basic Settings" in the following manual.

 MELSEC iQ-F FX5 Motion Module User's Manual (CC-Link IE TSN)

### 5. Module setting (Module Extended Parameter)

Set values for the settings related to axis control in "Module Extended Parameter" of the engineering tool.

For details, refer to "PARAMETER SETTINGS" in the following manual.

 MELSEC iQ-F FX5 Motion Module User's Manual (CC-Link IE TSN)

### 6. Refresh setting

Set values for the link refresh settings in "Basic Settings" of Module Parameter (Network).

For details, refer to "Basic Settings" in the following manual.

 MELSEC iQ-F FX5 Motion Module User's Manual (CC-Link IE TSN)

### 7. Programming

Create programs.

For details, refer to "PROGRAMMING [FX5-SSC-G]" in the following manual.

 MELSEC iQ-F FX5 Motion Module/Simple Motion Module User's Manual (Application)

### 8. Writing parameters

Write the set parameters and programs to the Motion module.

### 9. Network diagnostics

Use network diagnostics to check the cable connection status and whether the set parameters were transferred correctly.

For details, refer to "Checking the Network Status" in the following manual.

 MELSEC iQ-F FX5 Motion Module User's Manual (CC-Link IE TSN)

### 10. Device parameter setting

Set parameters for the drive units to be used.

Refer to the relevant drive unit manual for details.

MR-J5(W)-G:  MR-J5-G/MR-J5W-G User's Manual (Parameters)

### 11. Test operation

Confirm that the created programs are able to execute properly.

# 5 WIRING

## 5.1 Wiring [FX5-SSC-S]

### Precautions

The precautions for wiring the Simple Motion module are shown below. Execute the work following the precautions below.

#### Warning for wiring

##### **WARNING**

- Completely turn off the externally supplied power used in the system before installation or wiring. Not doing so could result in electric shock or damage to the product.

#### Caution for wiring

##### **CAUTION**

- Check the layout of the terminals and then properly route the wires to the module.
- The external input wiring connector must be crimped or pressured with the tool specified by the manufacturer, or must be correctly soldered. Insufficient connections may cause short circuit, fire, or malfunction.
- Be careful not to let foreign matter such as sawdust or wire chips get inside the module. These may cause fires, failure or malfunction.
- The top surface of the module is covered with protective films to prevent foreign objects such as cable off cuts from entering the module when wiring. Do not remove this film until the wiring is complete. Before operating the system, be sure to remove the film to provide adequate ventilation.
- Securely connect the connector for SSCNETIII cable to the bottom connector on the module.
- When removing the cable from the module, do not pull the cable. Hold the connector that is connected to the module. Pulling the cable that is still connected to the module may cause malfunction or damage to the module or cable.
- The external input/output signal cable and the communication cable should not be routed near or bundled with the main circuit cable, power cable and/or other such load - carrying cables other than those for the PLC. These cables should be separated by at least 100 mm (3.94 inch) or more. They can cause electrical interference, surges and inductance that can lead to mis-operation.
- The shielded cable for connecting Simple Motion module can be secured in place. If the shielded cable is not secured, unevenness or movement of the shielded cable or careless pulling on it could result in damage to the Simple Motion module, servo amplifier or shielded cable or defective cable connections could cause mis-operation of the unit.
- If the external input/output signal cable and the power line must be adjacently laid (less than 100 mm (3.94 inch)), use a shielded cable. Ground the shield of the cable securely to the control panel on the Simple Motion module side.
- Forcibly removal the SSCNETIII cable from the Simple Motion module will damage the Simple Motion module and SSCNETIII cables.
- After removal of the SSCNETIII cable, be sure to put a cap on the SSCNETIII connector. Otherwise, adhesion of dirt deteriorates in characteristic and it may cause malfunctions.
- Do not remove the SSCNETIII cable while turning on the power supply of Simple Motion module and servo amplifier. Do not see directly the light generated from SSCNETIII connector and the end of SSCNETIII cable. When the light gets into eye, may feel something wrong with eyes. (The light source of SSCNETIII cable complies with class1 defined in JISC6802 or IEC60825-1.)
- If a power such as a major shock, lateral pressure, haul, sudden bending or twist is added to the SSCNETIII cable, it distorts or breaks inside and optical transmission is not be available. Note that the short SSCNETIII cable can be twisted easily.
- Be sure to use the SSCNETIII cable within the range of operating temperature described in the manuals of each servo amplifier. Especially, as optical fiber for MR-J3BUS\_M and MR-J3BUS\_M-A are made of synthetic resin, it melts down if being left near the fire or high temperature. Therefore, do not make it touched the part which becomes high temperature, such as radiator or regenerative option of servo amplifier, or servo motor.
- When laying the SSCNETIII cable, be sure to secure the minimum cable bend radius or more.
- Put the SSCNETIII cable in the duct or fix the cable at the closest part to the Simple Motion module with bundle material in order to prevent SSCNETIII cable from putting its own weight on SSCNETIII connector. When laying cable, the optical cord should be given loose slack to avoid from becoming smaller than the minimum bend radius, and it should not be twisted. Also, fix and hold it in position with using cushioning such as sponge or rubber which does not contain plasticizing material. If adhesive tape for bundling the cable is used, fire resistant acetate cloth adhesive tape 570F (Teraoka Seisakusho Co., Ltd) is recommended.

## ⚠ CAUTION

- Migrating plasticizer is used for vinyl tape. Keep the MR-J3BUS\_M, and MR-J3BUS\_M-A cables away from vinyl tape because the optical characteristic may be affected. Generally, soft polyvinyl chloride (PVC), polyethylene resin (PE) and fluorine resin contain non-migrating plasticizer and they do not affect the optical characteristic of SSCNET III cable. However, some wire sheaths and cable ties, which contain migrating plasticizer (phthalate ester), may affect MR-J3BUS\_M and MR-J3BUS\_M-A cables (made of plastic). In addition, MR-J3BUS\_M-B cable (made of quartz glass) is not affected by plasticizer.

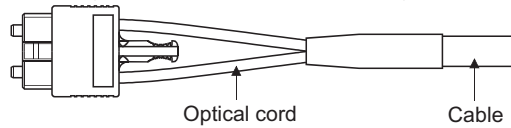

- : Normally, cable is not affected by plasticizer.
- △: Phthalate ester plasticizer such as DBP and DOP may affect optical characteristic of cable.

SSCNET III cable	Cord	Cable
MR-J3BUS_M	△	△
MR-J3BUS_M-A	△	△
MR-J3BUS_M-B	○	○

- If the adhesion of solvent and oil to the cord part of SSCNET III cable may lower the optical characteristic and machine characteristic. To use the cable in that environment, be sure to do the protection measures to the cord part.
- When keeping the Simple Motion module or servo amplifier, be sure to attach a cap to the connector part so that a dirt should not adhere to the end of SSCNET III connector.
- To protect a light device inside a connector from dust, a cap is attached to the SSCNET III connector for the SSCNET III cable. Therefore, do not remove a cap until just before connecting the SSCNET III cable. Also, when removing the SSCNET III cable, make sure to attach a cap.
- Keep the cap and the tube for protecting light cord end of SSCNET III cable in a plastic bag with a zipper included with the SSCNET III cable to prevent them from becoming dirty.
- When exchanging the Simple Motion module or servo amplifier, make sure to attach a cap to the SSCNET III connector. When asking repair of Simple Motion module or servo amplifier for some troubles, make also sure to attach a cap to the SSCNET III connector. When a cap is not attached, the light device may be damaged at the transit. In this case, exchange or repair of the light device is required.

## Precautions for wiring

- Use separate cables for connecting to the Simple Motion module and for the power cable that creates surge and inductance.
- The cable for connecting the Simple Motion module should be placed in the duct or secured in place by clamps. If the cable is not placed in the duct or secured by clamps, unevenness or movement of the cable or careless pulling on it could result in damage to the unit or cable or defective cable connections could cause mis-operation of the unit.
- If a duct is being used, separate the cables to connect the Simple Motion module from the power line duct, or use metal piping. Ground the pipes securely after metal piping.
- Use the twisted pair shielded cable (wire size 0.3 mm<sup>2</sup> or more). The shielded must be grounded on the Simple Motion module side.
- Use separate shielded cables for the external input signal, forced stop input, and manual pulse generator/incremental synchronous encoder input for connecting to the Simple Motion module. They can cause electrical interference, surges and inductance that can lead to mis-operation.
- When malfunctioning in environment with a lot of noise, the effects of noise may be reduced by the following measure. Please attach a ferrite core (Ex. TDK co., Ltd. ZCAT3035-1330 or similar) to the Simple Motion module side of the cable connected to the forced stop input signal, external command signal/switching signal, and manual pulse generator/incremental synchronous encoder input signal.
- For wiring, refer to the following manual and the manuals of each servo amplifier.

📖 MELSEC iQ-F FX5S/FX5UJ/FX5U/FX5UC User's Manual (Hardware)

## ■Wiring example of shielded cable

The following shows a wiring example for noise reduction when the connector (LD77MHIOCON) is used.

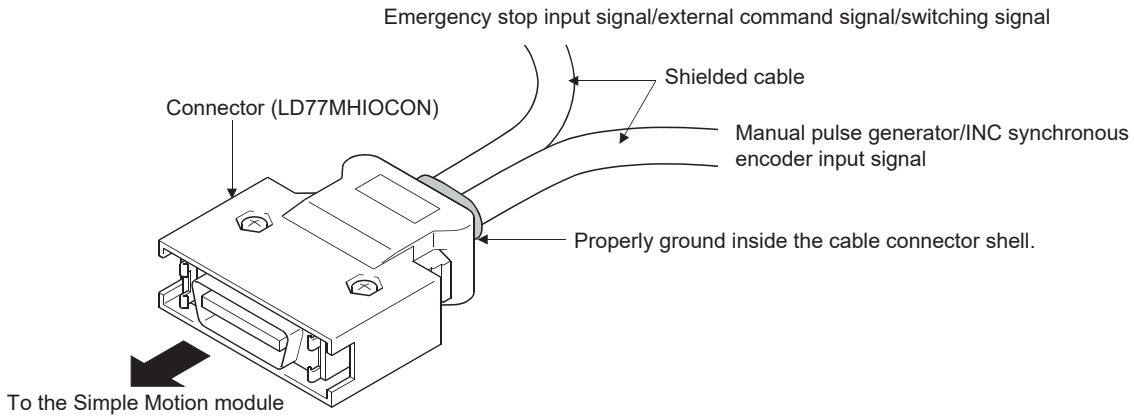

## ■Processing example of shielded cables

Connections of FG wire and each shielded cable

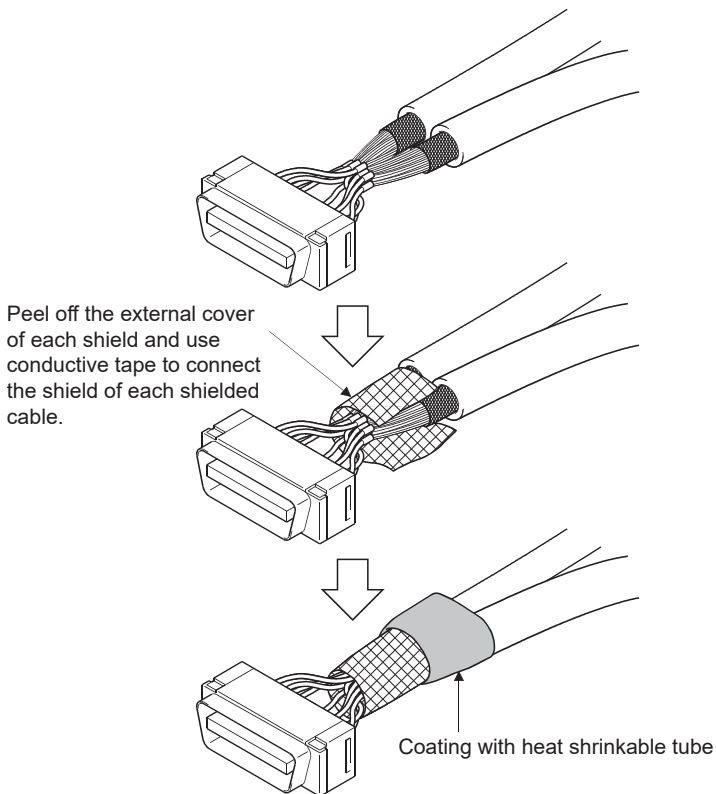

## ■Assembly of connector (LD77MHIOCON)

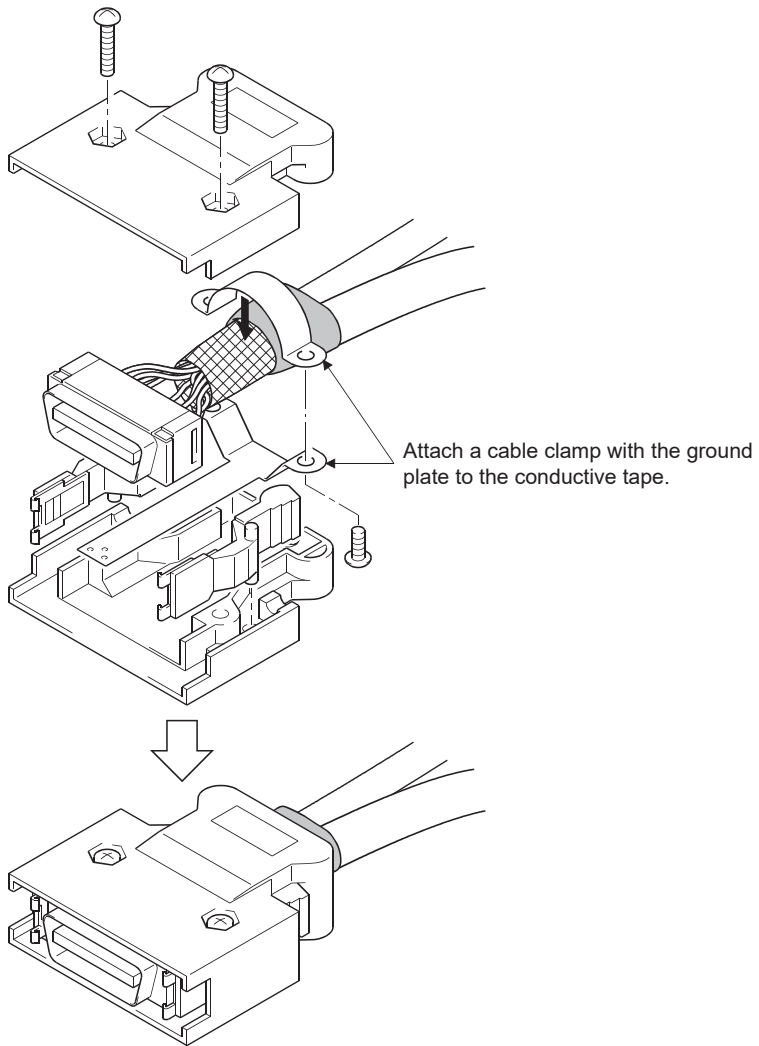

## Precautions for SSCNETIII cable wiring

SSCNETIII cable is made from optical fiber. If optical fiber is added a power such as a major shock, lateral pressure, haul, sudden bending or twist, its inside distorts or breaks, and optical transmission will not be available.

Especially, as optical fiber for MR-J3BUS\_M, MR-J3BUS\_M-A is made of synthetic resin, it melts down if left near a fire or an object with a high temperature. For this reason, keep the cable away from objects which can become hot, such as a radiator or regenerative option of servo amplifier and servo motor.

Be sure to use optical fiber within the range of operating temperature described in the manuals of each servo amplifier.

Read the described items of this section carefully and handle it with caution.

### ■Minimum bend radius

Make sure to lay the cable with greater radius than the minimum bend radius. Do not press the cable to edges of equipment or others. For SSCNETIII cable, the appropriate length should be selected with due consideration for the dimensions and arrangement of Simple Motion module or servo amplifier. When closing the door of control panel, make sure the SSCNETIII cable is not held down by the door and the cable bend does not become smaller than the minimum bend radius.

Model name of SSCNETIII cable	Minimum bend radius [mm] ([inch])
MR-J3BUS_M	25 (0.98)
MR-J3BUS_M-A	Enforced covering cord: 50 (1.97), Cord: 25 (0.98)
MR-J3BUS_M-B	Enforced covering cord: 50 (1.97), Cord: 30 (1.18)

### ■Tension

If tension is added on the SSCNETIII cable, the increase of transmission loss occurs because of external force which concentrates on the fixing part of SSCNETIII cable or the connecting part of SSCNETIII connector. At worst, the breakage of SSCNETIII cable or damage of SSCNETIII connector may occur. For cable laying, handle it with care without putting tension on the cables. (Refer to the manuals of each servo amplifier for the tension strength of SSCNETIII cable.)

### ■Lateral pressure

If lateral pressure is added on the SSCNETIII cable, the cable itself distorts, internal optical fiber gets stressed, and then transmission loss will increase. At worst, the breakage of SSCNETIII cable may occur. As the same condition also occurs at cable laying, do not tighten up SSCNETIII cable with a thing such as nylon band (TY-RAP).

Do not trample on it or tuck it down within the door of control box or others.

### ■Twisting

If the SSCNETIII cable is twisted, it will damage the cable in the same way as when local lateral pressure or bend is added. Consequently, transmission loss will increase, and damage to the SSCNETIII cable may occur.

### ■Disposal

When incinerating optical cables (cord) used for SSCNETIII cable, hydrogen fluoride gas or hydrogen chloride gas which is corrosive and harmful may be generated.

For disposal of SSCNETIII cable, request for specialized industrial waste disposal services that have incineration facilities for disposing hydrogen fluoride gas or hydrogen chloride gas.

## ■Wiring process of SSCNETⅢ cable

Put the SSCNET cable in the duct or fix the cable at the closest part to the Simple Motion module with bundle material in order to prevent SSCNET cable from putting its own weight on SSCNET connector. Leave the following space for wiring.

- Putting in the duct

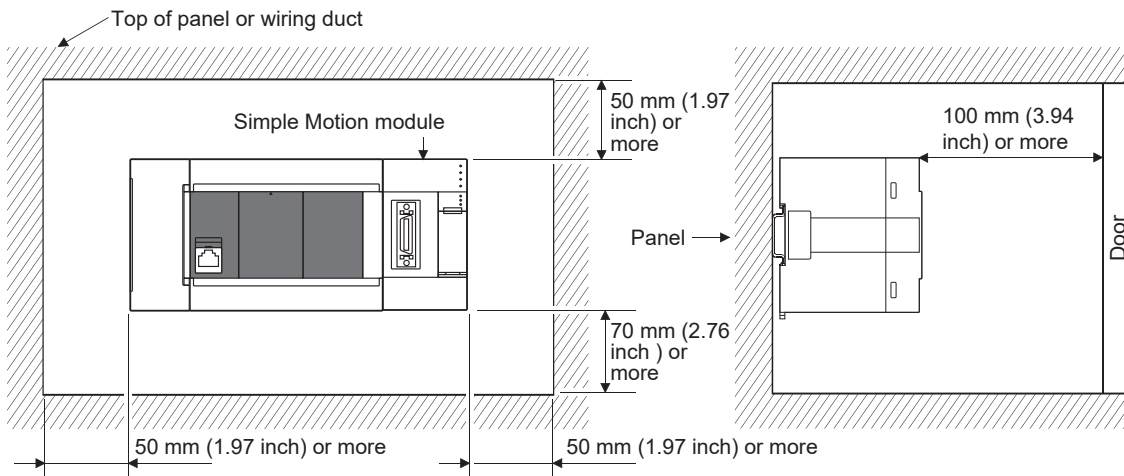

- Bundle fixing

Optical cord should be given loose slack to keep it from becoming smaller than the minimum bend radius, and it should not be twisted. When laying cable, fix and hold it in position with using cushioning such as sponge or rubber which does not contain plasticizing material.

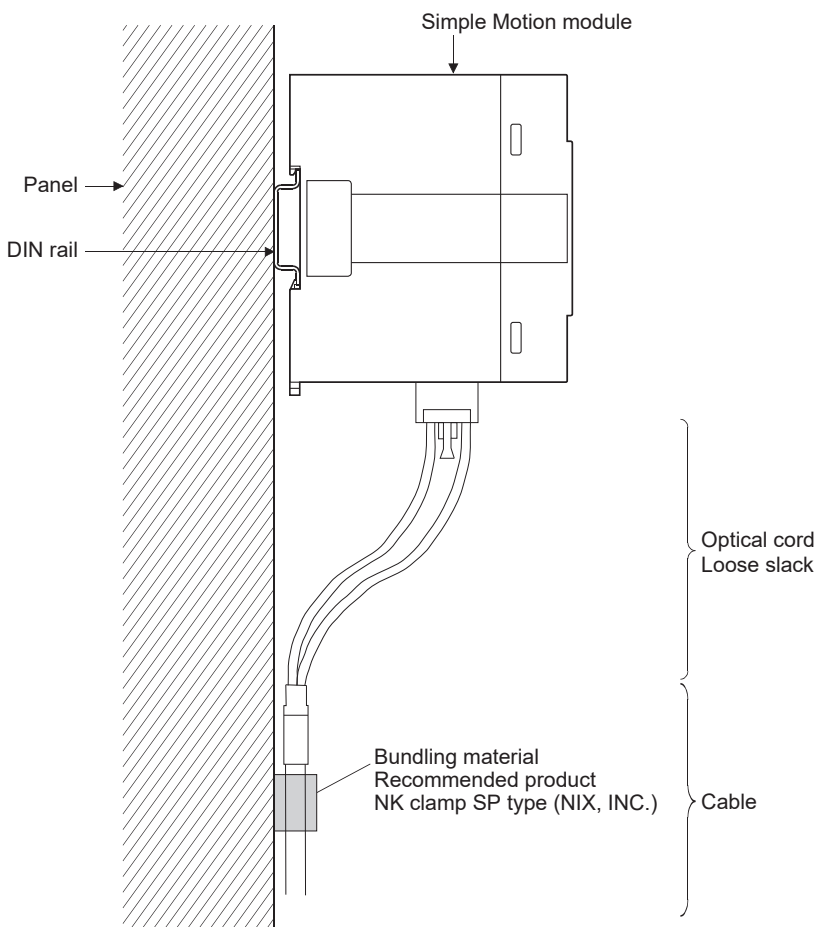

## 5.2 Wiring [FX5-SSC-G]

The following describes the wiring methods, wiring products, and precautions for wiring when using the FX5-SSC-G.

### Wiring for CC-Link IE TSN

#### Wiring methods

The following describes connection and disconnection of the Ethernet cable.

##### ■Connecting the cable

1. Turn OFF the power supply of the Motion module and the device being connected.
2. Push the Ethernet cable connector into the Motion module until it clicks. Pay attention to the connector's direction.
3. Lightly pull it to check that it is securely connected.
4. Turn ON the power of the Motion module and the external device.
5. Check whether the LINK LED of the port connected with an Ethernet cable is ON.\*1

\*1 The time between the Ethernet cable connection and the LINK LED turning on may vary. The LINK LED usually turns on in a few seconds. Note, however, that the time may be extended further if the link up processing is repeated depending on the status of the device on the line. If the LINK LED does not turn on, refer to "Troubleshooting using the LEDs" in the following manual and take corrective actions.

 MELSEC iQ-F FX5 Motion Module/Simple Motion Module User's Manual (Application)

##### ■Disconnecting the cable

1. Turn OFF the power supply of the Motion module.
2. Press the latch down and unplug the Ethernet cable.

#### Wiring products

The following describes the devices used for CC-Link IE TSN.

##### ■Ethernet cable

Use an Ethernet cable that meets the following standards.

Communication speed	Ethernet cable	Connector	Standard
1 Gbps	Category 5e or higher, straight cable (double-shielded, STP)	RJ45 connector	The following conditioning cables: <ul style="list-style-type: none"><li>• IEEE802.3 (100BASE-T)</li><li>• ANSI/TIA/EIA-568-B (Category 5e)</li></ul>
100 Mbps	Category 5 or higher, straight cable (double-shielded, STP)	RJ45 connector	The following conditioning cables: <ul style="list-style-type: none"><li>• IEEE802.3 (100BASE-TX)</li><li>• ANSI/TIA/EIA-568-B (Category 5)</li></ul>

Cables for CC-Link IE TSN are available from Mitsubishi Electric System & Service Co., Ltd. (Catalogs for cable are also available.)

In addition, the connector processing of cable length is available for your preference. Please consult your local Mitsubishi representative.

Communication speed	Type	Model (Manufacturer)
1 Gbps	Category 5e or higher, straight cable (double-shielded, STP)	SC-E5EW series (Mitsubishi Electric System & Service Co., Ltd.)

#### Point

A communication error may occur due to high-frequency noise from devices other than a programmable controller in a given connection environment. The following describes countermeasures to be taken on the Motion module side to avoid high-frequency noise influence.

- Use a double-shielded type cable.
- Do not bundle the cable with the main circuit or power cable or do not place it near those lines.
- Place the cable in a duct.

## Industrial switch

Use the following industrial switches.

Term	Description	CC-Link IE TSN class
Industrial switch (for CC-Link IE TSN Class B) <sup>*1</sup>	For the models and usage methods of the industrial switches, refer to the CC-Link Partner Association website (www.cc-link.org).	CC-Link IE TSN Class B device
Industrial switch (for CC-Link IE TSN Class A) <sup>*2</sup>		CC-Link IE TSN Class A device

\*1 The following industrial switch (for CC-Link IE TSN Class B) is recommended.

Type	Model (Manufacturer)	Reference
CC-Link IE TSN industrial managed switch	NZ2MHG-TSNT□ (Mitsubishi Electric Corporation)	 CC-Link IE TSN Industrial Managed Ethernet Switch User's Manual

\*2 When CC-Link IE TSN Class A devices supporting the CC-Link IE TSN Protocol version 2.0 are connected to an industrial switch (for CC-Link IE TSN Class A), set the VLAN function of the industrial switch (for CC-Link IE TSN Class A) to "Disabled". If the VLAN function is set to "Enabled", cyclic transmission cannot be performed with CC-Link IE TSN Class A devices that support CC-Link IE TSN Protocol version 2.0.

An industrial switch can be used for cascade connection.

When the industrial switch is used for cascade connection, check the specifications of the industrial switch used.

## Precautions

- Since there are different restrictions for system configurations using an industrial switch (for CC-Link IE TSN Class B) and system configurations using an industrial switch (for CC-Link IE TSN Class A), setting with an engineering tool is required. For details, refer to "SYSTEM CONFIGURATION" in the following manual.  
 MELSEC iQ-F Motion Module User's Manual (CC-Link IE TSN)
- Do not configure a ring topology when modules are connected to an industrial switch. Doing so, all stations will fail and data links cannot be performed.

# Precautions

Be sure to follow the precautions for wiring. Otherwise, some functions may not operate normally. (They may operate normally temporarily.)

- The bending radius of the Ethernet cable is limited. For details, check the specifications of the Ethernet cable to be used.
- Place the Ethernet cable in a duct or clamp it. If not, dangling cable may swing or inadvertently be pulled, resulting in damage to the module or cables or a malfunction due to poor contact.
- When installing a cable, do not touch the core of the cable-side or module-side connector, and protect it from dirt or dust. If oils from your hands, dirt or dust is attached to the core, it can increase transmission loss, arising a problem in a data link.
- Hold the connector part when connecting and disconnecting the Ethernet cable. Pulling the cable connected to the module may result in malfunction or damage to the module or cable.
- Check that the Ethernet cable is not disconnected or not shorted and there is no problem with the connector connection.
- Do not use Ethernet cables with broken latches. Doing so may cause the cable to be unplugged or malfunction.
- For connectors without Ethernet cables, attached caps should be mounted to prevent foreign matter such as dirt or dust.
- The maximum station-to-station distance of the Ethernet cable is 100 m (328.08 ft.). However, the length may be shorter depending on the operating environment of the cable. For details, contact the manufacturer of the cable used.
- In a line topology, do not connect a device station with no IP address setting or a device station that is not in the master station's network configuration between the master station and a device station or between device stations. A data link may not be performed between the master station and device stations with no IP address setting or device stations that are connected after the connection of a device station that is not in the master station's network configuration.

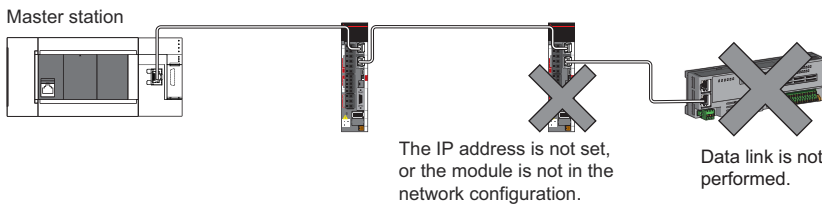

- Communication with the Ethernet-compatible device may not be performed depending on the specifications of the connected Ethernet-compatible device or industrial switch. If communications are not possible, reduce the communication data volume of the Ethernet-compatible device.

# 5.3 Power Supply Wiring

## Power supply connector

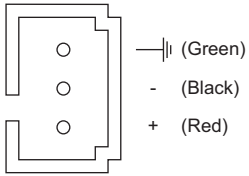

## Power supply wiring

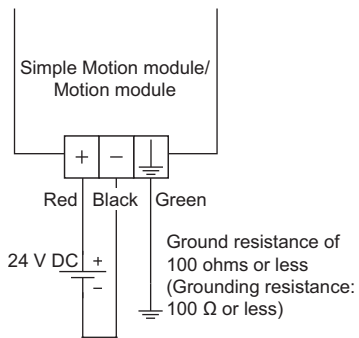

# 5.4 Grounding

Observe the following:

- Provide grounding with a ground resistance of 100Ω or less.
- Provide independent grounding when possible.
- If independent grounding cannot be provided, provide "shared grounding" as shown below.

Independent grounding (Best condition)

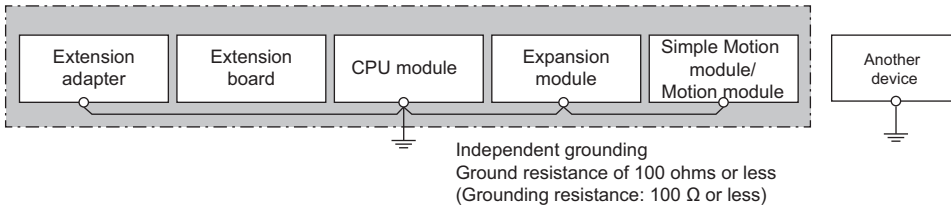

Shared grounding (Good condition)

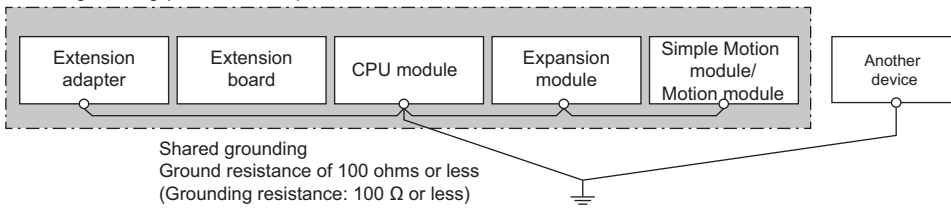

Common grounding (Not allowed)

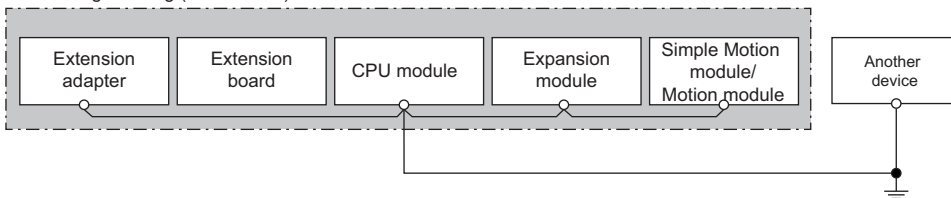

- Keep the distance between the grounding point and the programmable controller as close as possible to shorten the length of ground cable.

## 5.5 External Input Connection Connector [FX5-SSC-S]

### Signal layout for external input connection connector

The signal layout for the external input connection connector of Simple Motion module is shown below.

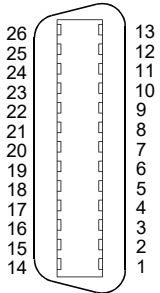
Pin layout (Front view of the module)	Pin No.	Signal name	Pin No.	Signal name		
	1	No connect <sup>*5</sup>	14	No connect <sup>*5</sup>		
	2	SG	Signal ground	15	SG	Signal ground
	3	HA <sup>*1*2*3</sup>	Manual pulse generator/ Incremental synchronous encoder A-phase/PULSE	16	HB <sup>*1*2*3</sup>	Manual pulse generator/ Incremental synchronous encoder B-phase/SIGN
	4	HAH <sup>*1*2*4</sup>		17	HBH <sup>*1*2*4</sup>	
	5	HAL <sup>*1*2*4</sup>		18	HBL <sup>*1*2*4</sup>	
	6	No connect <sup>*5</sup>		19	No connect <sup>*5</sup>	
	7			20		
	8			21		
	9			22		
	10	EMI	Forced stop input signal	23	EMI.COM	Forced stop input signal common
	11	DI1 <sup>*6</sup>	External command/ Switching signal	24	DI2 <sup>*6</sup>	External command/ Switching signal
	12	DI3 <sup>*6</sup>		25	DI4 <sup>*6</sup>	
	13	COM <sup>*7</sup>	Common (COM)	26	COM <sup>*7</sup>	Common (COM)

\*1 Input type from manual pulse generator/incremental synchronous encoder is switched in "[Pr.89] Manual pulse generator/Incremental synchronous encoder input type selection". (Only the value specified for axis 1 is valid).

0: Differential-output type

1: Voltage-output/open-collector type (Default value)

\*2 Set the signal input form in "[Pr.24] Manual pulse generator/Incremental synchronous encoder input selection".

\*3 Manual pulse generator/Incremental synchronous encoder input selection/open-collector type

Connect the A-phase/PULSE signal to HA, and the B-phase/SIGN signal to HB.

\*4 Manual pulse generator/Incremental synchronous encoder input selection in Differential-output type

Connect the A-phase/PULSE signal to HAH, and the A-phase/PULSE inverse signal to HAL.

Connect the B-phase/SIGN signal to HBH, and the B-phase/SIGN inverse signal to HBL.

\*5 Do not connect to any of the terminal explained as "No connect".

\*6 Set the external command signal [DI] in "[Pr.95] External command signal selection".

\*7 Common terminal for DI1 to DI4.

# List of input signal details

Signal name	Pin No.	Signal details		
Differential-output type	HAH (A+)	4	<p>(1) A-phase/B-phase</p> <ul style="list-style-type: none"> <li>Input the pulse signal from the manual pulse generator/incremental synchronous encoder A-phase and B-phase.</li> <li>If the A-phase leads the B-phase, the positioning address will increase at the rising and falling edges of each phase.</li> <li>If the B-phase leads the A-phase, the positioning address will decrease at the rising and falling edges of each phase.</li> </ul> <p>(a) Magnification by 4</p> <p>[When increased]</p> <p>[When decreased]</p> <p>(b) Magnification by 2</p> <p>[When increased]</p> <p>[When decreased]</p>	
	HAL (A-)	5		
	Manual pulse generator/ Incremental synchronous encoder B-phase/SIGN	HBH (B+)		17
		HBL (B-)		18
Voltage-output type/open-collector type	HA (A)	3	<p>(2) PULSE/SIGN</p> <p>Input the pulse signal for counting the increased/decreased pulse in the pulse input (PULSE). Input the signal for controlling forward run and reverse run in the direction sign (SIGN).</p> <p>1) "[Pr.151] Manual pulse generator/Incremental synchronous encoder input logic selection" is positive logic</p> <ul style="list-style-type: none"> <li>The motor will forward run when the direction sign is HIGH.</li> <li>The motor will reverse run when the direction sign is LOW.</li> </ul> <p>2) "[Pr.151] Manual pulse generator/Incremental synchronous encoder input logic selection" is negative logic</p> <ul style="list-style-type: none"> <li>The motor will forward run when the direction sign is LOW.</li> <li>The motor will reverse run when the direction sign is HIGH.</li> </ul>	
	HB (B)	16	<p>(c) Magnification by 1</p> <p>1) Positive logic</p> <p>[When increased]</p> <p>[When decreased]</p> <p>2) Negative logic</p> <p>[When increased]</p> <p>[When decreased]</p>	

Signal name		Pin No.	Signal details
External command signal/ Switching signal	(DI1)	11	<ul style="list-style-type: none"> <li>Input a control switching signal during speed-position or position-speed switching control.</li> <li>Use this signal as the input signal of positioning start, speed change request, skip request and mark detection from an external device. Set the function to use this signal in "[Pr.42] External command function selection". Set the signal in "[Pr.95] External command signal selection".</li> </ul>
	(DI2)	24	
	(DI3)	12	
	(DI4)	25	
Common (COM)		13 26	<ul style="list-style-type: none"> <li>Common for external command/switching signals.</li> </ul>
Forced stop input signal (EMI)		10	<ul style="list-style-type: none"> <li>This signal is input when batch forced stop is available for all axes of servo amplifier.</li> </ul>
Forced stop input signal common (EMI.COM)		23	EMI ON (Opened): Forced stop EMI OFF (24 V DC input): Forced stop release
Signal ground (SG)		2 15	The signal ground in the case of using manual pulse generator/INC synchronous encoder.

## Interface internal circuit

The outline diagrams of the internal circuits for the external device connection interface (for the Simple Motion module) are shown below.

### Interface between external command signals/switching signals

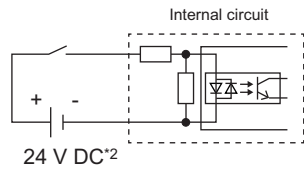
Input or Output	Signal name		Pin No.				Wiring example	Description
			1	2	3	4		
Input	External command signal/Switching signal	DI_* <sup>1</sup>	11	24	12	25	 <p>24 V DC<sup>2</sup></p>	External command signal/ Switching signal
		COM	13 26					

\*1 \_ = 1 to 4

\*2 As for the 24 V DC polarity, both "+" and "-" are possible.

### Interface with forced stop input signals

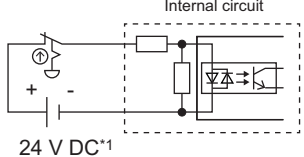
Input or Output	Signal name		Pin No.		Wiring example	Description
Input	Forced stop input	EMI	10		 <p>24 V DC<sup>1</sup></p>	Forced stop input signal
		EMI.COM	23			

\*1 As for the 24 V DC polarity, both "+" and "-" are possible.

## Manual pulse generator/Incremental synchronous encoder input

### Interface between manual pulse generator/incremental synchronous encoder (Differential-output type)

Input or Output	Signal name	Pin No.	Wiring example
Input <sup>*1,*2</sup>	Manual pulse generator, A-phase/PULSE	HAH (A+)	4
		HAL (A-)	5
	Manual pulse generator, B-phase/SIGN	HBH (B+)	17
		HBL (B-)	18
Signal ground	SG	2 15	

\*1 Set "0: Differential-output type" in "[Pr.89] Manual pulse generator/Incremental synchronous encoder input type selection" if the manual pulse generator/Incremental synchronous encoder of differential-output type is used.

The default value is "1: Voltage-output/open-collector type".

\*2 Set the signal input form in "[Pr.24] Manual pulse generator/Incremental synchronous encoder input selection".

### Interface between manual pulse generator/Incremental synchronous encoder (Voltage-output type/open-collector type)

Input or Output	Signal name	Pin No.	Wiring example
Input <sup>*1,*2</sup>	Manual pulse generator, A-phase/PULSE	HA (A)	3
	Manual pulse generator, B-phase/SIGN	HB (B)	16
Signal ground	SG	2 15	

\*1 Set "1: Voltage-output/open-collector type" in "[Pr.89] Manual pulse generator/Incremental synchronous encoder input type selection" if the manual pulse generator/Incremental synchronous encoder of voltage-output/open-collector type is used.

The default value is "1: Voltage-output/open-collector type".

\*2 Set the signal input form in "[Pr.24] Manual pulse generator/Incremental synchronous encoder input selection".

## Wiring example for manual pulse generator/incremental synchronous encoder

Wire the manual pulse generator/incremental synchronous encoder of differential output type and voltage output type/open-collector type as follows.

Switch the input type of FX5-SSC-S by "[Pr.89] Manual pulse generator/Incremental synchronous encoder input type selection".

Use the external 5 V power supply (5 V DC±5%) for the power supply of the manual pulse generator/incremental synchronous encoder.

Connect the 0 V (-) of the manual pulse generator/incremental synchronous encoder and the SG of FX5-SSC-S.

Select the external power supply with due consideration for the capacity of manual pulse generator/incremental synchronous encoder.

### Manual pulse generator/Incremental synchronous encoder of differential output type

Recommended wiring example

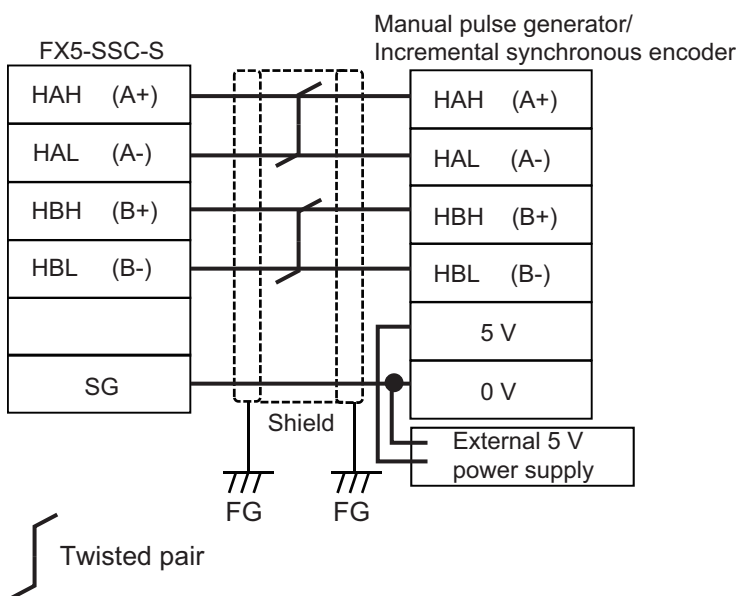

### Manual pulse generator/Incremental synchronous encoder of voltage output type/open-collector type

Recommended wiring example

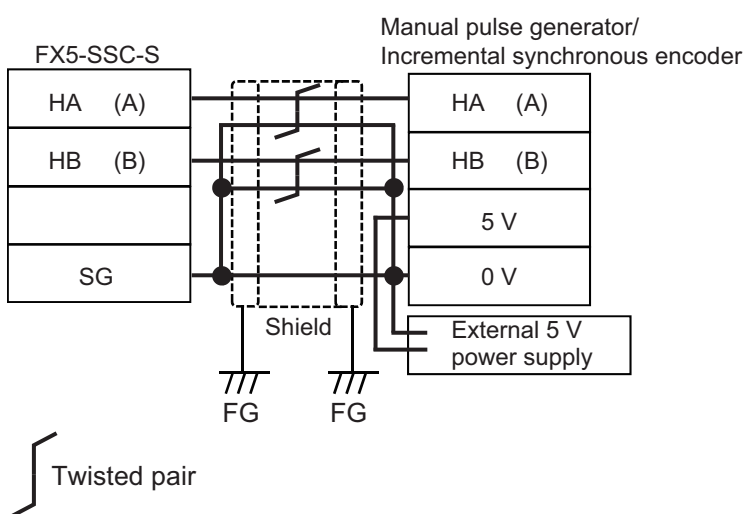

# APPENDICES

## Appendix 1 Component List [FX5-SSC-S]

The positioning system using the Simple Motion module is configured of the following devices.

No.	Part name	Type	Remarks
1	Simple Motion module	FX5-40SSC-S	
		FX5-80SSC-S	
2	Servo amplifier	—	—
3	SSCNETIII cable	—	Cables are needed for connecting the Simple Motion module with a servo amplifier, or between servo amplifiers. (☞ Page 77 Reference product)
4	External input signal cable	—	Cables are needed for connecting the Simple Motion module with an external device. (Prepare them referring to the manuals for the connected devices and information given in the following. ☞ Page 72 Signal layout for external input connection connector)

### Reference product

#### Connection cable

The cables for connecting between the Simple Motion module and servo amplifiers. Refer to the manuals of each servo amplifier for details.

For long distance cables over 50 m (164.04 ft.) and cables with an ultra-long bending life, refer to SSCNETIII cables manufactured by Mitsubishi Electric System & Service Co., Ltd. (☞ Page 78 SSCNETIII cables manufactured by Mitsubishi Electric System & Service Co., Ltd (SC-J3BUS\_M-C))

#### ■SSCNETIII cable

\_ = Cable length

(015: 0.15 m (0.49 ft.), 03: 0.3 m (0.98 ft.), 05: 0.5 m (1.64 ft.), 1: 1 m (3.28 ft.), 3: 3 m (9.84 ft.), 5: 5 m (16.40 ft.), 10: 10 m (32.81 ft.), 20: 20 m (65.62 ft.), 30: 30 m (98.43 ft.), 40: 40 m (131.23 ft.), 50: 50 m (164.04 ft.))

Model name		Cable length [m (ft.)]	Description
MR-J3BUS_M (Standard cord for inside panel)	MR-J3BUS015M	0.15 (0.49)	<ul style="list-style-type: none"> <li>Simple Motion module ↔ MR-J5(W)-B/MR-J4(W)-B/MR-JE-B(F)/MR-J3(W)-B</li> <li>MR-J5(W)-B/MR-J4(W)-B/MR-JE-B(F)/MR-J3(W)-B ↔ MR-J5(W)-B/MR-J4(W)-B/MR-JE-B(F)/MR-J3(W)-B</li> </ul>
	MR-J3BUS03M	0.3 (0.98)	
	MR-J3BUS05M	0.5 (1.64)	
	MR-J3BUS1M	1 (3.28)	
	MR-J3BUS3M	3 (9.84)	
MR-J3BUS_M-A (Standard cable for outside panel)	MR-J3BUS5M-A	5 (16.40)	
	MR-J3BUS10M-A	10 (32.81)	
	MR-J3BUS20M-A	20 (65.62)	
MR-J3BUS_M-B (Long distance cable)	MR-J3BUS30M-B	30 (98.43)	
	MR-J3BUS40M-B	40 (131.23)	
	MR-J3BUS50M-B	50 (164.04)	

A

## ■SSCNETⅢ cables manufactured by Mitsubishi Electric System & Service Co., Ltd (SC-J3BUS\_M-C)

Cables are available in lengths from 1 m (3.28 ft.) to 100 m (328.08 ft.) in increments of 1 m (3.28 ft.). A number indicating the cable length (1 to 100) is included in the "\_ " portion of the model name.

Model name	Cable length [m (ft.)]	Bending life	Description
SC-J3BUS_M-C	1 to 100 (3.28 to 328.08)	Ultra-long	Long distance cable

### Point

- For details of the SSCNETⅢ cables, consult your nearest Mitsubishi representative.
- Do not look directly at the light generated by the CN1A and CN1B connectors of the servo amplifier or the tip of the SSCNETⅢ cable. The light can cause discomfort if it enters the eyes.

## Connection connector

The connector for the external input wiring.

[External input wiring connector]

Part name	Specification
Applicable connector	LD77MHIOCON
Applicable wire size	AWG30 to 24 (0.05 to 0.2 mm <sup>2</sup> )*1

\*1 AWG24 (0.2 mm<sup>2</sup>) is recommended.

## Specifications of recommended manual pulse generator

Item	Specification
Model name	MR-HDP01
Ambient temperature	-10 to 60°C
Pulse resolution	25 pulses/rev (100 pulses/rev after magnification by 4)
Output method	Voltage-output, Output current Max. 20 mA
Power supply voltage	4.5 to 13.2 V DC
Current consumption	60 mA
Output level	"H" level: Power supply voltage *1 - 1 V or more (in no load) "L" level: 0.5 V or less (with maximum leading-in)
Life time	1000000 revolutions (at 200 r/min)
Permitted axial loads	Radial load: Max. 19.6 N Thrust load: Max. 9.8 N
Weight	0.4 [kg]
Number of max. revolution	Instantaneous Max. 600 r/min. normal 200 r/min
Pulse signal status	2 signals: A-phase, B-phase, 90° phase difference
Start friction torque	0.06 N•m (20°C)

\*1 Use a stabilized power supply of voltage 5 V DC ± 0.25 V.

## Manual pulse generator that the operation has been checked

Manufacturer	Model name
Nemicon Corporation*1	UFO-M2-0025-2Z1-B00E

\*1 Contact: <https://www.nemicon.co.jp/en/>

# External dimension drawing of manual pulse generator

MR-HDP01 (Manufactured by Mitsubishi Electric Corporation)

[Unit: mm (inch)]

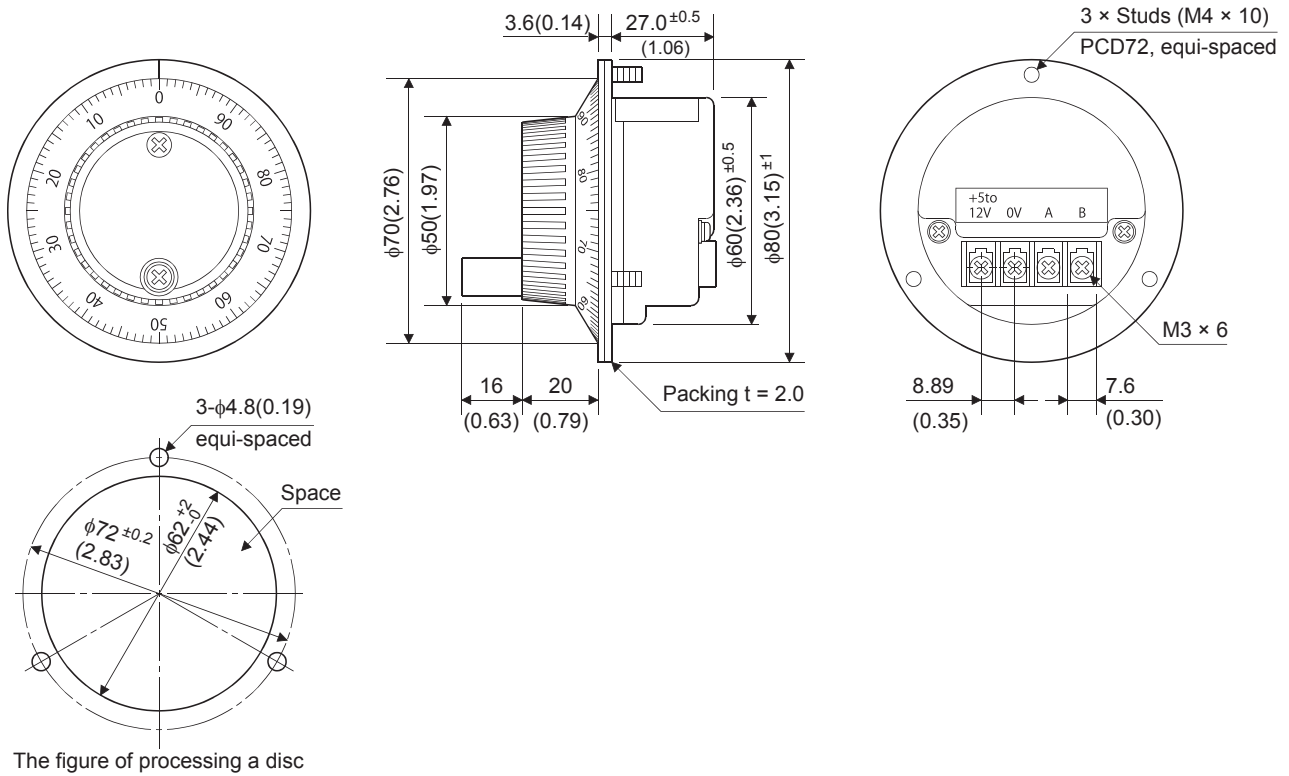

A

## Serial absolute synchronous encoder specifications

Item	Specifications
Model name	Q171ENC-W8*1
Ambient temperature	-5 to 55°C
Resolution	4194304 pulses/rev
Transmission method	Serial communications (Connected to MR-J4-B-RJ)
Direction of increasing addresses	CCW (viewed from end of shaft)
Protective construction	Dustproof/Waterproof (IP67: Except for the shaft-through portion.)
Permitted speed at power ON	3600 r/min
Permitted speed at power OFF*2	500 r/min
Permitted axial loads	Radial load: Up to 19.6 N, Thrust load: Up to 9.8 N
Runout at input shaft tip	0.02 mm (0.00079 inch) or less, (15 mm (0.59 inch) from tip)
Start friction torque	0.04 N•m (20°C)
Recommended coupling	Bellows coupling
Permitted angular acceleration	40000 rad/s <sup>2</sup>
Vibration resistance	5 G (50 to 200 Hz)
Shock resistance	50 G (11 ms or less)
Internal current consumption [A]	0.25
Mass [kg]	0.6
Connecting cable [m (ft.)]	Q170ENCCBL_M (_ = Cable length: 2 (6.56), 5 (16.40), 10 (32.81), 20 (65.62), 30 (98.43), 50 (164.04))
Communications method	Differential driver/receiver
Transmission distance	Up to 50 m (164.04 ft.)

\*1 If an "o-ring" is required, the user should purchase it separately.

\*2 If it exceeds a permitted speed at power OFF, a position displacement is generated.



The serial absolute synchronous encoder backs up the absolute position with the battery for back up of absolute position data of the servo amplifier (MR-J4-B-RJ) it is connected to.

## Specifications of serial absolute synchronous encoder input (CN2L) of servo amplifier

Item	Specifications
Applicable types	Q171ENC-W8
Applicable signal types	Differential-output type: (SN75C1168 or equivalent)
Transmission method	Serial communications
Synchronous method	Counter-clock-wise (viewed from end of shaft)
Communication speed	2.5 Mbps
Position detection method	Absolute (ABS) method
Resolution	4194304 pulses/rev (22 bit)
Number of modules	1/module (MR-J4-B-RJ)
External connector type	20 pin connector
Applicable connector for the external connection	MR-J3CN2 (Optional)
Connecting cable [m (ft.)]	Q170ENCCBL_M-A (_ = Cable length: 2 (6.56), 5 (16.40), 10 (32.81), 20 (65.62), 30 (98.43), 50 (164.04))
Cable length	Up to 50 m (164.04 ft.)
Back up the absolute position.	Depends on the battery (MR-BAT6V1SET).
Battery service life time (value in actual)	10000 [h] (When MR-BAT6V1SET is used while the device is turned OFF at the ambient temperature of 25°C)

## Serial absolute synchronous encoder cable

For the serial absolute synchronous encoder cables, please use our products. If the required length is not found in our products, the user should fabricate a cable.

### ■ Selection

The following table indicates the serial absolute synchronous encoder cables used with the serial absolute synchronous encoder. Connector sets (MR-J3CN2) are also available for your fabrication.

Cable model	Cable length [m (ft.)]
Q170ENCCBL_M-A	2 (6.56), 5 (16.40), 10 (32.81), 20 (65.62), 30 (98.43), 50 (164.04)

Use the following or equivalent twisted pair cables as the serial absolute synchronous encoder cables.

Connector sets type	Description
MR-J3CN2	Servo amplifier connector

Core size [mm <sup>2</sup> ]	Number of cores	Characteristics of one core			Finished OD [mm] <sup>*2</sup>
		Structure [Number of wires/mm]	Conductor resistance [Ω/km]	Insulating sheath OD d [mm] <sup>*1</sup>	
0.2	24 (12 pairs)	40/0.08	105 or less	0.88	9.0

\*1 d is as shown below.

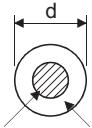

Conductor    Insulation sheath

\*2 Standard OD (Outside Diameter). Maximum OD is about 10% larger.

## CAUTION

- When fabricating the encoder cable, do not make an incorrect connection. An incorrect connection will cause runaway or an explosion.

A

## ■Q170ENCCBL\_M-A

- Model explanation

Type: Q170ENCCBL\_M - A

Symbol	Cable length [m (ft.)]
2	2 (6.56)
5	5 (16.40)
10	10 (32.81)
20	20 (65.62)
30	30 (98.43)
50	50 (164.04)

- Connection diagram

When fabricating a cable, use the recommended wire and connector set MR-J3CN2 for encoder cable given above, and make the cable as shown in the following connection diagram. Maximum cable length is 50 m (164.04 ft.).

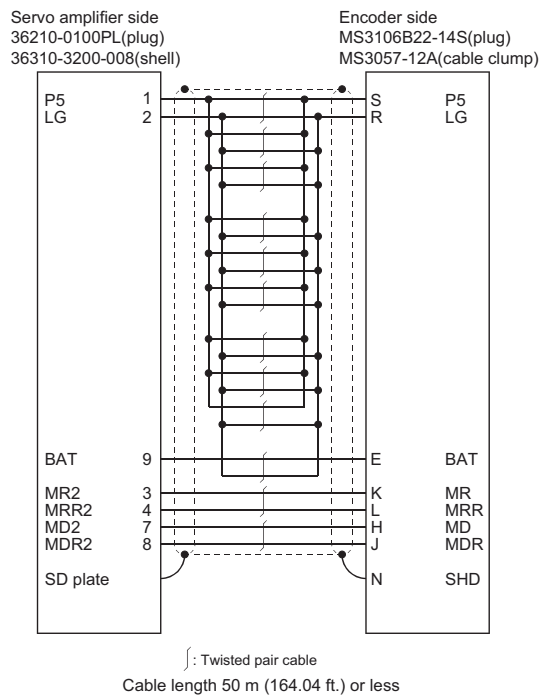
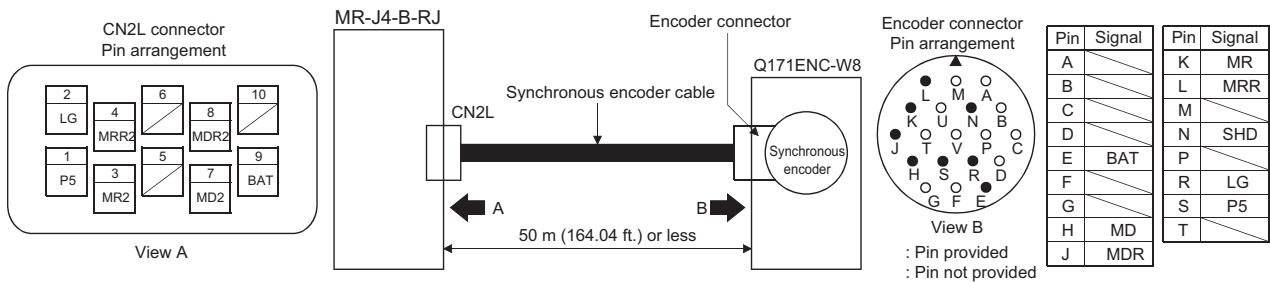

Layout twisted pair for signal to avoid contact.

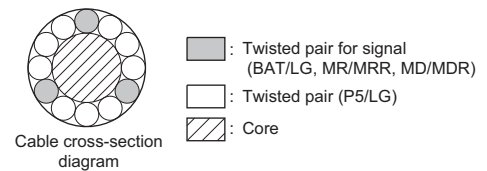

## External dimension drawing of serial absolute synchronous encoder

### Serial absolute synchronous encoder (Q171ENC-W8)

[Unit: mm (inch)]

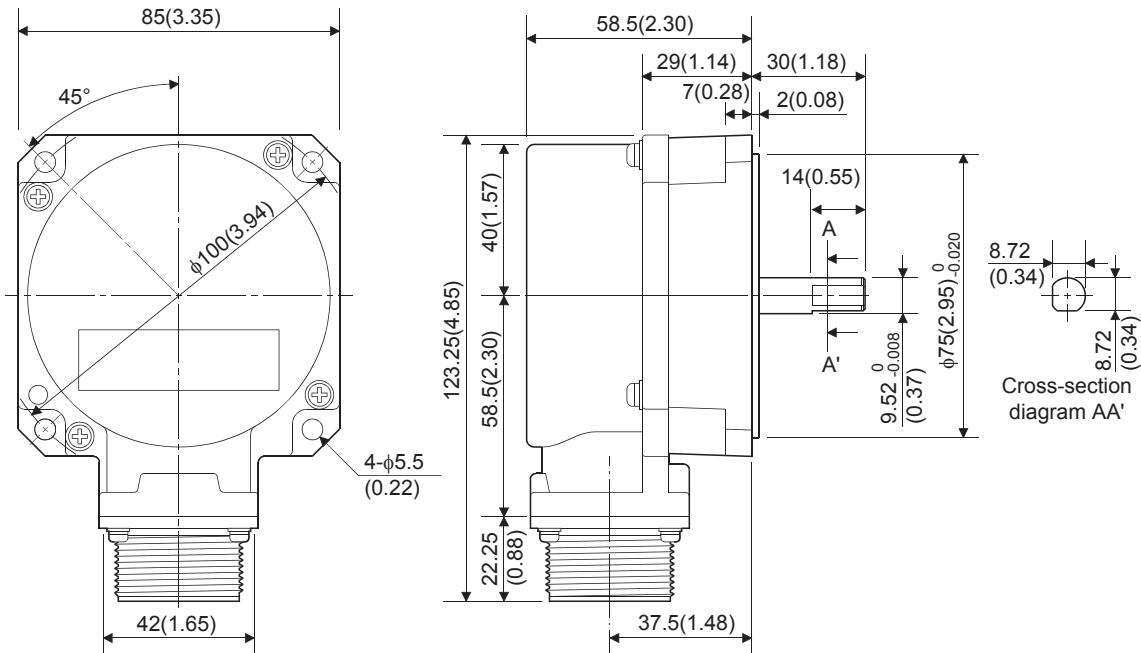

## Cable connector for serial absolute synchronous encoder

### Type (manufactured by 3M Japan Limited (SCR type))

Plug: 36210-0100PL

Shell: 36310-3200-008

[Unit: mm (inch)]

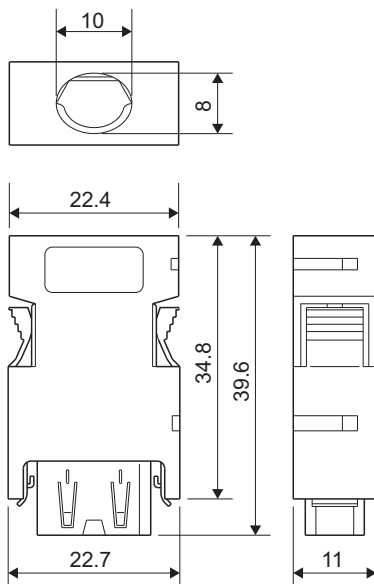

A

## Mounting of serial absolute synchronous encoder

This section describes precautions for handling the serial absolute synchronous encoder.

- If the serial absolute synchronous encoder is linked to a chain, a timing belt, or gears, the machine side rotary shaft should be supported by a separate bearing and connected to the serial absolute synchronous encoder through a bellows coupling. Ensure that excessive force (greater than the permitted shaft load) is not applied to the shaft of the serial absolute synchronous encoder.

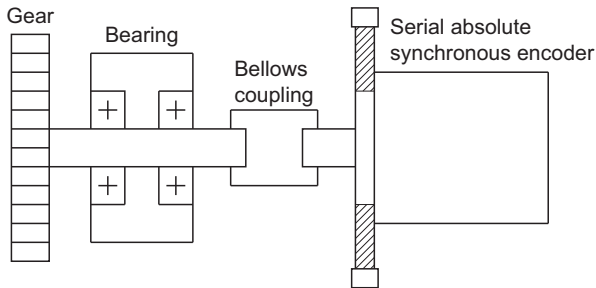

Item	Radial direction	Thrust direction
Permitted shaft load	Up to 19.6 N	Up to 9.8 N

- Excessive load applied to the shaft of the serial absolute synchronous encoder by large mounting errors in eccentricity or angle of deviation may impair encoder function or extremely shorten encoder life. Minimize loads applied to the shaft so that they remain within the permitted shaft load range.

### CAUTION

- The serial absolute synchronous encoder contains a glass disk and precision mechanism. Take care when handling it. Encoder function may be impaired if it is dropped or subjected to shocks or vibrations exceeding the prescribed limits.
- Do not connect the shaft of the serial absolute synchronous encoder directly to the machine side rotary shaft. The shaft should be supported by a separate bearing and mounted using a bellows coupling.
- Never hit the end of the serial absolute synchronous encoder shaft with a hammer or similar object when doing things such as connecting the bellows coupling to it. Excessive shock applied to the serial absolute synchronous encoder may damage it.
- The serial absolute synchronous encoder uses optical parts. Mount it in an atmosphere containing as little moisture, oil, and dust as possible.
- When mounting the serial absolute synchronous encoder to any place where it is exposed to water and/or oil, provide protection from oil and water, e.g. mount a cover. In addition, run the cable downward to prevent oil and/or water from travelling on the cable into the serial absolute synchronous encoder. When it is necessary to mount the serial absolute synchronous encoder vertically or obliquely, set up a trap on the cable.
- Use the serial absolute synchronous encoder within the specified temperature range (-5 to 55°C).
- Do not use rigid couplings. Doing so applies an excessive bending load to the axis, and may break the axis of the servo motor or cause deterioration of the bearings.

# Appendix 2 Component List [FX5-SSC-G]

The positioning system using the Motion module is configured of the following devices.

No.	Part name	Type	Remarks
1	Motion module	FX5-40SSC-G	FX5- <span style="border: 1px solid black; padding: 0 2px;">  </span> SSC-G G: Compatible with CC-Link IE TSN Number of controlled axes (40 = 4 axes, 80 = 8 axes)
		FX5-80SSC-G	
2	Drive unit	—	—
3	Device compatible with CC-Link IE TSN	—	—
4	Ethernet cable	—	Cables are needed for connecting the Motion module with a drive unit/device compatible with CC-Link IE TSN, or between drive units/devices compatible with CC-Link IE TSN. (☞ Page 67 Ethernet cable)
5	Industrial switch	—	Industrial switches are needed for connecting the Motion module, a drive unit, and other brand drive units in star topology. (☞ Page 68 Industrial switch)

## Operation-verified manual pulse generator

Manufacturer	Model name
Tokyo Sokuteikizai Co., Ltd.	RE46A2CO2B

When using a manual pulse generator with the FX5-SSC-G, connect the encoder with the input part of the CPU module or the extension high-speed pulse input/output module, then import the manual pulse generator data using the high-speed counter function of the CPU module.

For details of the high-speed counter function, refer to the following manual.

📖 MELSEC iQ-F FX5 User's Manual (Application)

For the wiring of the high-speed counter, refer to the following manuals.

📖 MELSEC iQ-F FX5S/FX5UJ/FX5U/FX5UC User's Manual (Hardware)

# Appendix 3 Connection with External Devices [FX5-SSC-S]

## Connector

Mounted onto an external input connection connector of the Simple Motion module and used for wiring an external device. The "external device connector" includes the following 3 types.

### Connector type

Type		Model name	
		Connector	Connector case
Soldering type (LD77MHIOCON)	One-touch lock style	10126-3000PE	10326-52F0-008
Soldering type* <sup>1</sup>	Screw tightening style	10126-3000PE	10326-52A0-008
Pressure-displacement type* <sup>1</sup>	One-touch lock style	10126-6000EL	10326-3210-000

\*<sup>1</sup> Make sure to purchase the connector which is sold separately since this is not an option.

### Specifications of the connector

Part name	Specification	
Applicable connector	Soldering type (One-touch lock style/Screw tightening style)	Pressure-displacement type (One-touch lock style)
Applicable wire size	AWG30 to AWG24 (0.05 to 0.2 mm <sup>2</sup> )	AWG28 (twisted, 0.08 mm <sup>2</sup> )

The external input wiring connector has not been prepared. The user should purchase it separately.

### ■Specialized tool

- Manual harness tool for pressure-displacement type (Manufactured by Sumitomo 3M Limited.)

Model name
10960 (Press body)
10962 (Fixture unit)
10963 (Fixture block)
10964-1 (Cable clamp (small) for 14 to 50 poles)

- Contact for the specialized tool

Sumitomo 3M Limited: <https://www.3m.com/>

# External input signal cable

The external input signal cable is not prepared as an option. The user should fabricate a cable.

## Connection diagram

Make the cable as shown in the following connection diagram.

### ■Differential-output type

Make the cable within 30 m (98.5 ft.).

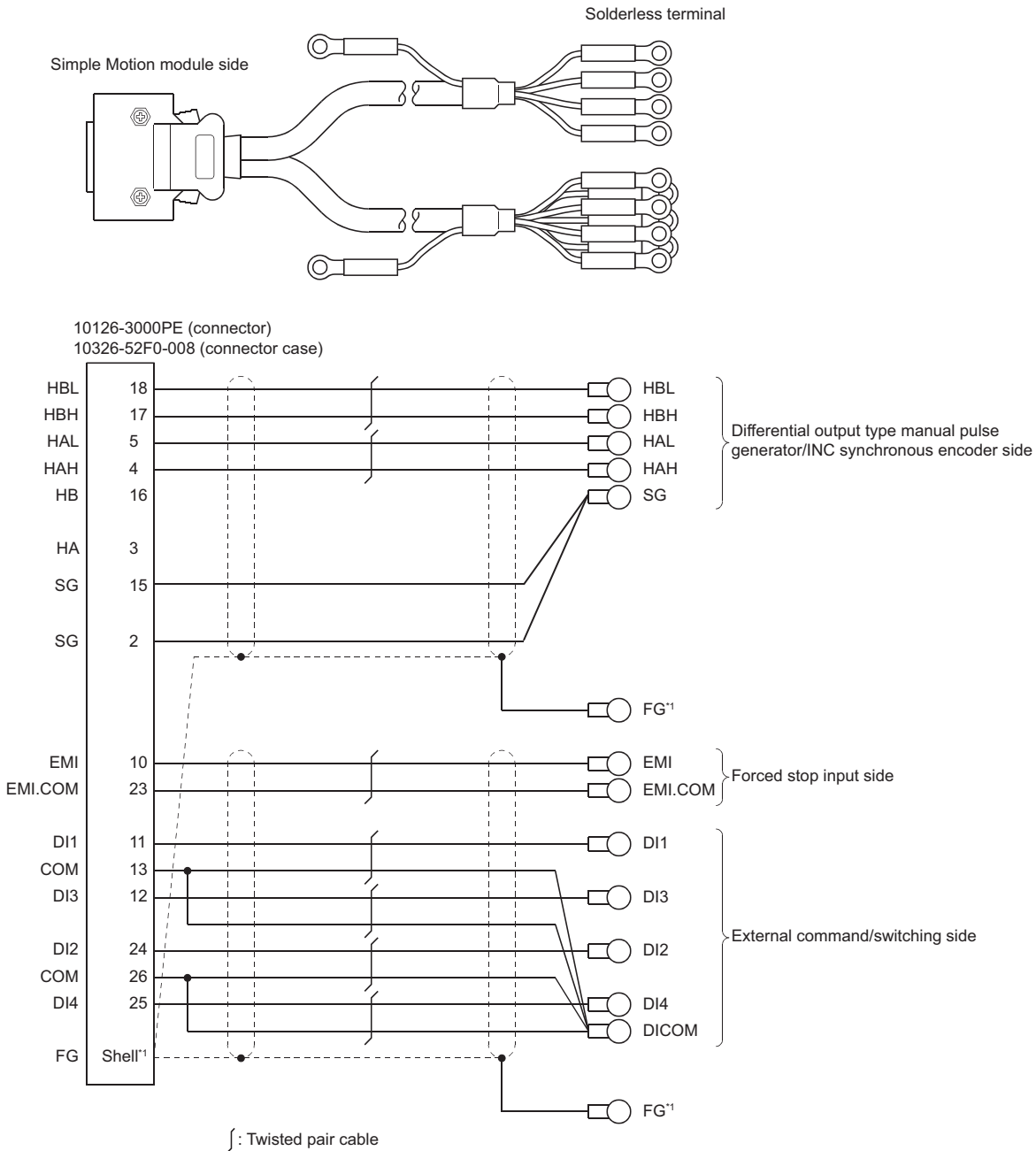

\*1 Make sure to perform shield treatment on the used equipment side. Also, connect it to the shell of connector side.



## ■ Voltage-output type/Open-collector type

Make the cable within 10 m (32.81 ft.).

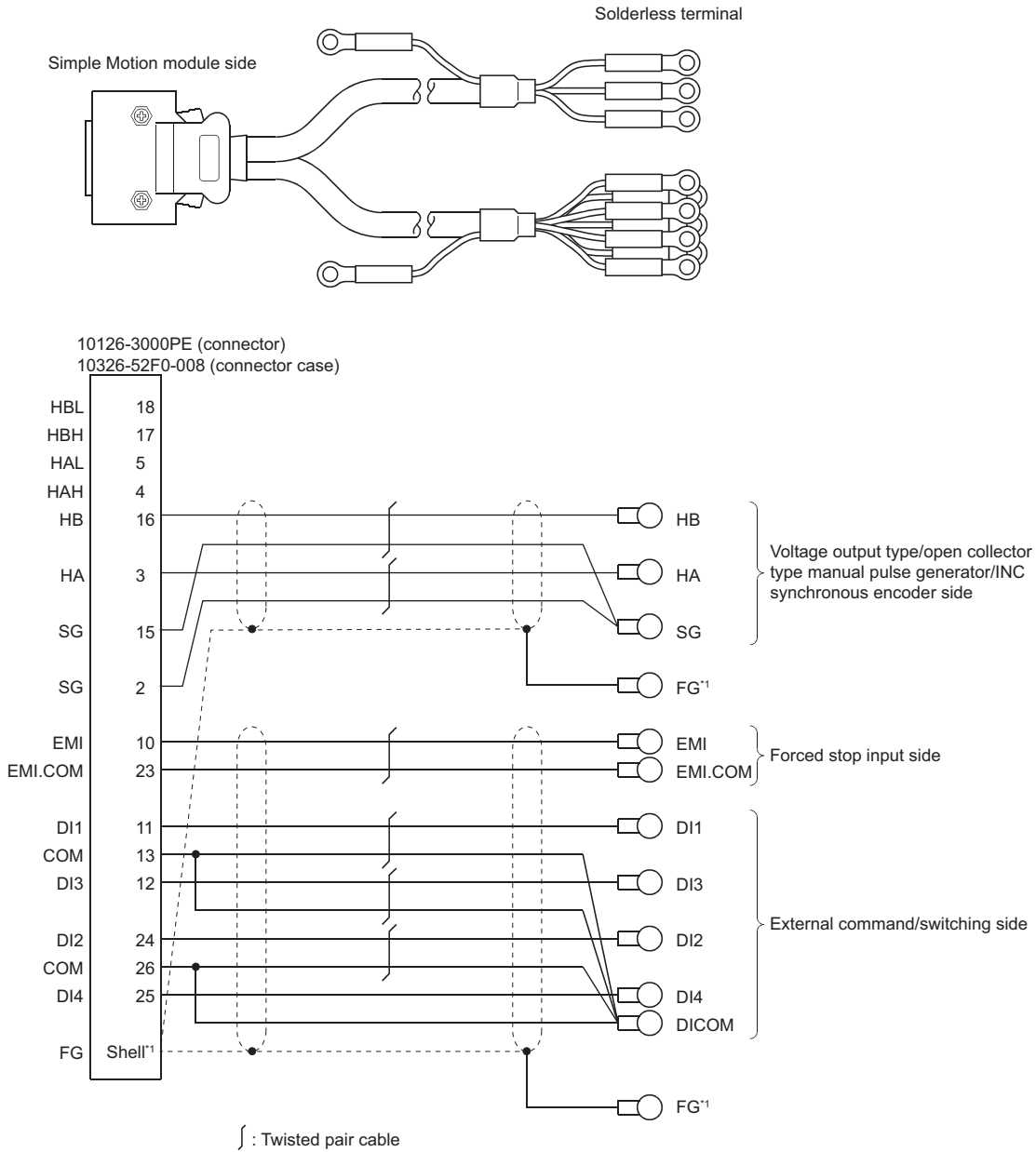

\*1 Make sure to perform shield treatment on the used equipment side. Also, connect it to the shell of connector side.

## ■Wire specifications

- The following table indicates the external input wiring connector cables. Select a cable according to your operating conditions.

Wire model	Core size	Number of cores	Characteristics of one core			Finish OD [mm] <sup>*2</sup>
			Structure [Number of wires/mm]	Conductor resistance [ $\Omega$ /km]	Insulating sheath OD d [mm] <sup>*1</sup>	
20276FACBL 7/0.18 mm×4P	AWG25 (0.16 mm <sup>2</sup> )	8 (4 pairs)	7/0.18TA	115	1.0	6.8
20276FACBL 7/0.18 mm×5P	AWG25 (0.16 mm <sup>2</sup> )	10 (5 pairs)	7/0.18TA	115	1.0	7.3

\*1 d is as shown below.

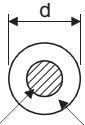

Conductor    Insulation sheath

\*2 Standard OD. Max. OD is about 10% larger.

## CAUTION

- When fabricating the cable, do not make an incorrect connection. An incorrect connection will cause runaway or an explosion.

# Appendix 4 How to Check the SERIAL No.

---

The SERIAL No. of the Simple Motion module/Motion module can be checked in the following method.

## Confirming the serial No. on the rating plate

The rating plate is situated on the side face of the Simple Motion module/Motion module. (☞ Page 21 PART NAMES)

# Appendix 5 External Dimensions

## FX5-40SSC-S

[Unit: mm (inch)]

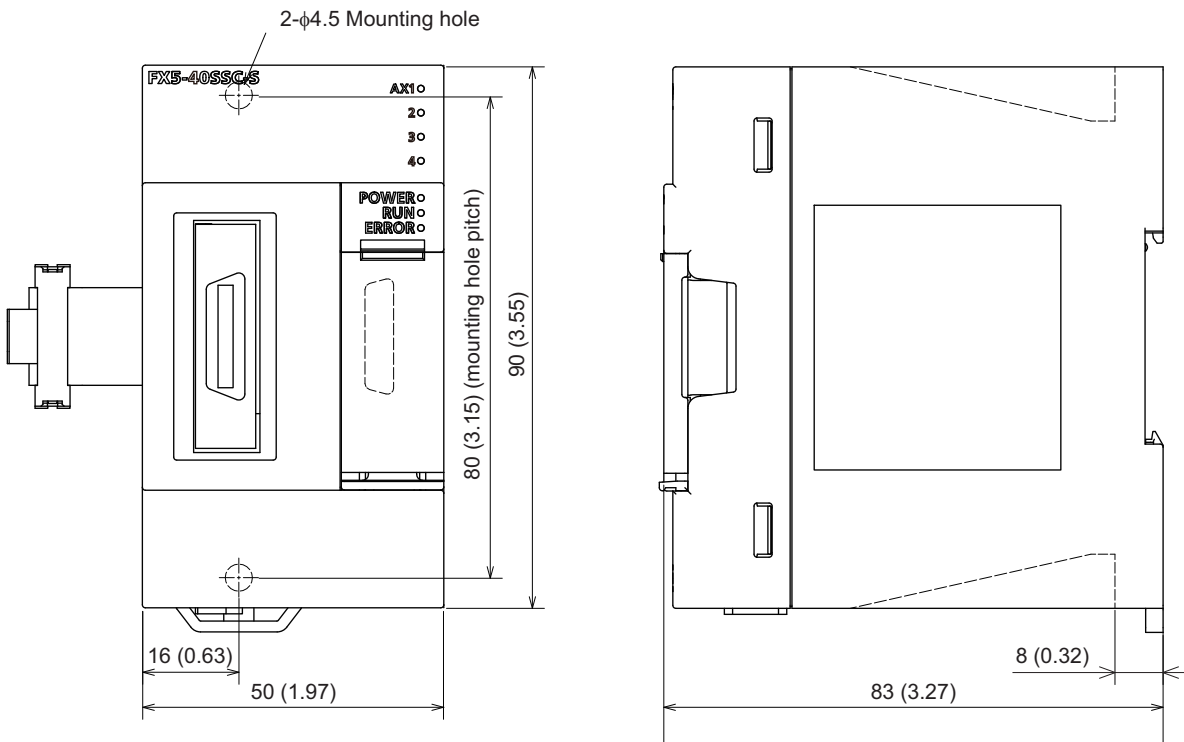

## FX5-80SSC-S

[Unit: mm (inch)]

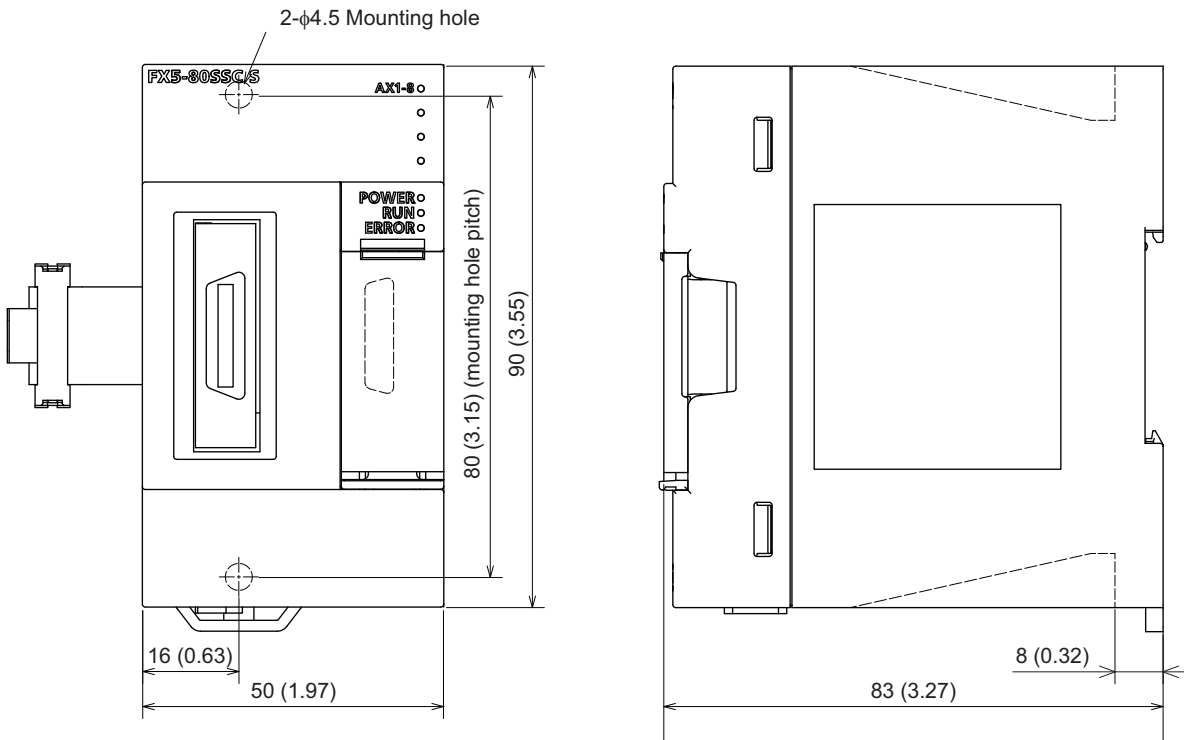

A

## FX5-40SSC-G

[Unit: mm (inch)]

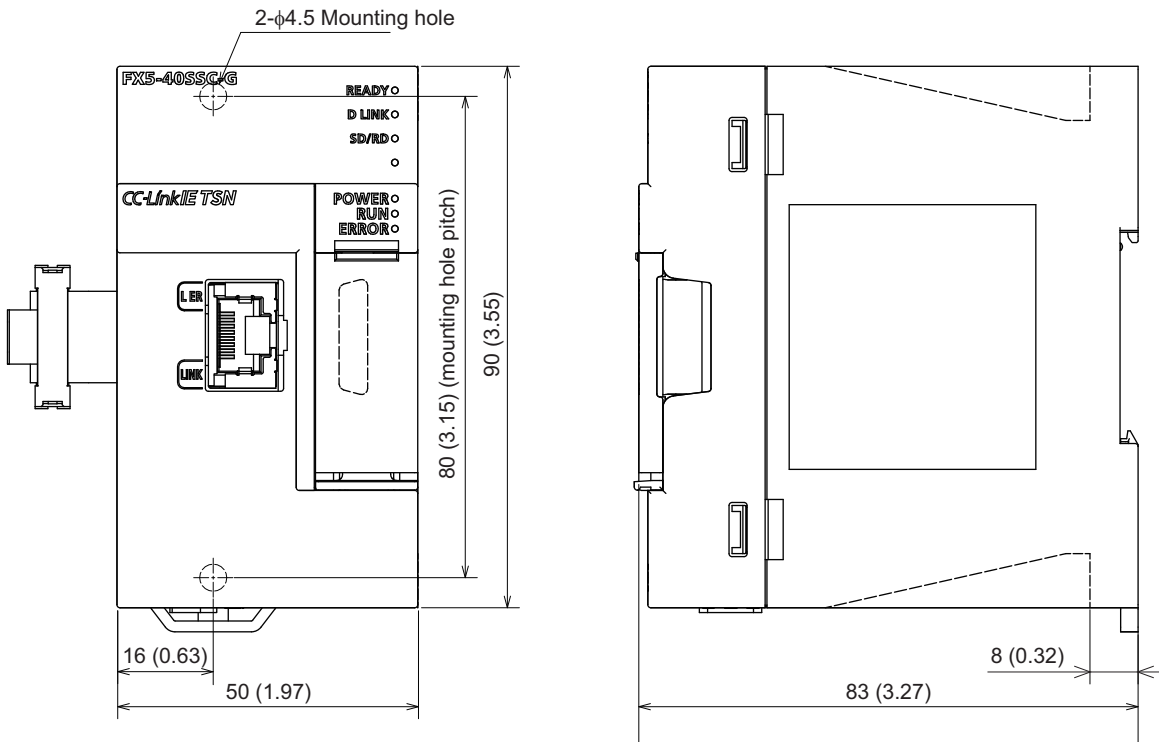

## FX5-80SSC-G

[Unit: mm (inch)]

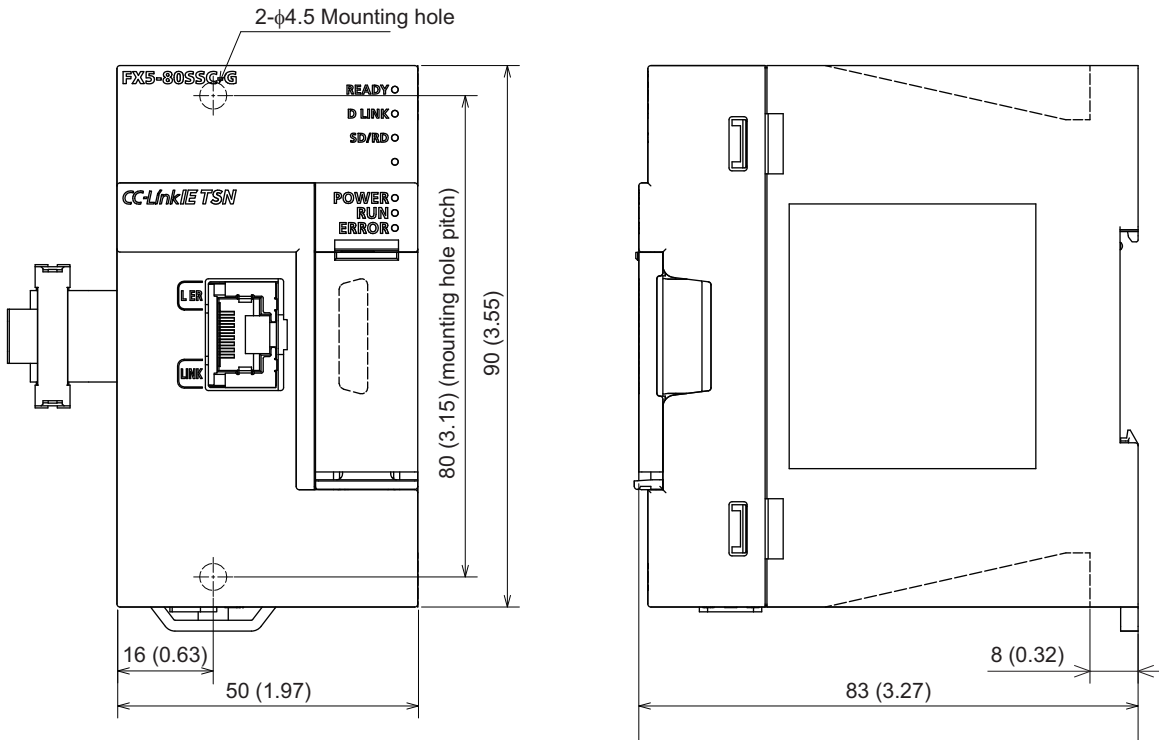

# Appendix 6 Standard Compliant Models

## Models compliant with UL and cUL standards

The FX5-SSC-S and FX5-SSC-G are compliant with the EU Directive (EMC Directive) and UL standards (UL, cUL).  
For models compliant with the UL Standards, please consult your local Mitsubishi representative. UL, cUL File Number: E95239

## EU Directive (CE marking) compliance

The entire machinery manufactured by using this product is not guaranteed to conform to the following directives.  
The manufacturer of the machinery must determine whether to declare conformity to the EMC Directive and the Low Voltage Directive (LVD).  
For details, consult Mitsubishi Electric separately.

## Measures to comply with the EMC Directive

The following product, when used in accordance with instructions given by the relevant document, shows conformity to the EU directive (2014/30/EU) for electromagnetic compatibility through direct testing (using the following specified standards) and design analysis (by creating a technical structure file).

### Product conformity item

Type: Programmable controller (open-type device)

Target products: FX5 manufactured in the following periods

Manufactured on and after October 1, 2014	FX5-40SSC-S
Manufactured on and after October 1, 2016	FX5-80SSC-S
Manufactured on and after January 1, 2021	FX5-40SSC-G, FX5-80SSC-G

Electromagnetic Compatibility (EMC) Directive	Remarks
EN 61131-2:2007 Programmable Controllers -Equipment requirements and tests	The product has been tested for all related items from the following. EMI • Radiated emission • Conducted emission EMS • Radiated electromagnetic field • Fast transient burst • Electrostatic discharge • High-energy surge • Voltage drops and interruptions • Conducted RF • Power frequency magnetic field [FX5-SSC-S]

A

## Precautions for compliance with the EU Directive

---

### Precautions when using the product

---

Attach a ferrite core to the power supply cable (on the Simple Motion module/Motion module side).

Attach the ferrite core with the cable wrapped around it two times at a location that is 200 mm or less from the Simple Motion module/Motion module side connector.

For the ferrite core, use a core that is equivalent to the following:

- Model: ZCAT3035-1330 manufactured by TDK Corporation

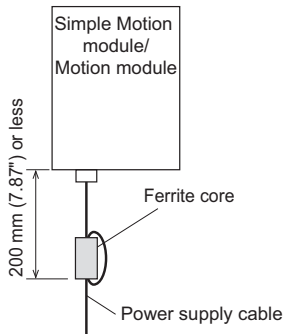

### Power source of 24 V DC power supply voltage

---

Supply power to the 24 V DC power supply voltage of the FX5-SSC-S/FX5-SSC-G from the AC/DC power supply installed in the same control panel.

### Compliance with UKCA marking

---

The requirements for compliance with UKCA marking are the same as that with EU directive (CE marking).

# Appendix 7 Open Source Software

---

The software of the Motion module includes the following open software.

- Distributed software as a free software in which copyright of a third-party exists.

Software which Mitsubishi Electric Corporation or a third-party hold copyright cannot be subjected to a distribution of the source cord.

Besides, please refrain inquiry as to the source cord of the open source.

## RapidJSON

RapidJSON distributed by MIT license is used on this product. Copyright notice and license notice of RapidJSON are included below.

Tencent is pleased to support the open source community by making RapidJSON available.

Copyright (C) 2015 THL A29 Limited, a Tencent company, and Milo Yip. All rights reserved.

If you have downloaded a copy of the RapidJSON binary from Tencent, please note that the RapidJSON binary is licensed under the MIT License.

If you have downloaded a copy of the RapidJSON source code from Tencent, please note that RapidJSON source code is licensed under the MIT License, except for the third-party components listed below which are subject to different license terms. Your integration of RapidJSON into your own projects may require compliance with the MIT License, as well as the other licenses applicable to the third-party components included within RapidJSON. To avoid the problematic JSON license in your own projects, it's sufficient to exclude the bin/jsonchecker/ directory, as it's the only code under the JSON license. A copy of the MIT License is included in this file.

Permission is hereby granted, free of charge, to any person obtaining a copy of this software and associated documentation files (the "Software"), to deal in the Software without restriction, including without limitation the rights to use, copy, modify, merge, publish, distribute, sublicense, and/or sell copies of the Software, and to permit persons to whom the Software is furnished to do so, subject to the following conditions:

The above copyright notice and this permission notice shall be included in all copies or substantial portions of the Software.

The Software shall be used for Good, not Evil.

THE SOFTWARE IS PROVIDED "AS IS", WITHOUT WARRANTY OF ANY KIND, EXPRESS OR IMPLIED, INCLUDING BUT NOT LIMITED TO THE WARRANTIES OF MERCHANTABILITY, FITNESS FOR A PARTICULAR PURPOSE AND NONINFRINGEMENT. IN NO EVENT SHALL THE AUTHORS OR COPYRIGHT HOLDERS BE LIABLE FOR ANY CLAIM, DAMAGES OR OTHER LIABILITY, WHETHER IN AN ACTION OF CONTRACT, TORT OR OTHERWISE, ARISING FROM, OUT OF OR IN CONNECTION WITH THE SOFTWARE OR THE USE OR OTHER DEALINGS IN THE SOFTWARE.

A

## msinttypes

msinttypes distributed by BSD license is used on this product. Copyright notice and license notice of msinttypes are included below.

The msinttypes r29

Copyright (c) 2006-2013 Alexander Chemeris

All rights reserved.

Redistribution and use in source and binary forms, with or without modification, are permitted provided that the following conditions are met:

- \* Redistributions of source code must retain the above copyright notice, this list of conditions and the following disclaimer.
- \* Redistributions in binary form must reproduce the above copyright notice, this list of conditions and the following disclaimer in the documentation and/or other materials provided with the distribution.
- \* Neither the name of copyright holder nor the names of its contributors may be used to endorse or promote products derived from this software without specific prior written permission.

THIS SOFTWARE IS PROVIDED BY THE REGENTS AND CONTRIBUTORS ``AS IS'' AND ANY EXPRESS OR IMPLIED WARRANTIES, INCLUDING, BUT NOT LIMITED TO, THE IMPLIED WARRANTIES OF MERCHANTABILITY AND FITNESS FOR A PARTICULAR PURPOSE ARE DISCLAIMED. IN NO EVENT SHALL THE REGENTS AND CONTRIBUTORS BE LIABLE FOR ANY DIRECT, INDIRECT, INCIDENTAL, SPECIAL, EXEMPLARY, OR CONSEQUENTIAL DAMAGES (INCLUDING, BUT NOT LIMITED TO, PROCUREMENT OF SUBSTITUTE GOODS OR SERVICES; LOSS OF USE, DATA, OR PROFITS; OR BUSINESS INTERRUPTION) HOWEVER CAUSED AND ON ANY THEORY OF LIABILITY, WHETHER IN CONTRACT, STRICT LIABILITY, OR TORT (INCLUDING NEGLIGENCE OR OTHERWISE) ARISING IN ANY WAY OUT OF THE USE OF THIS SOFTWARE, EVEN IF ADVISED OF THE POSSIBILITY OF SUCH DAMAGE.

## C++ B-tree

C++ B-tree distributed by Apache License, Version 2.0 is used on this product. For copyright notice and license notice of Apache License, Version 2.0, refer to the following.

<http://www.apache.org/licenses/LICENSE-2.0>

## MD5 Message-Digest Algorithm

MD5 Message-Digest Algorithm is used on this product. Copyright notice and license notice of MD5 Message-Digest Algorithm are included below.

Copyright (C) 1991-2, RSA Data Security, Inc. Created 1991. All rights reserved.

License to copy and use this software is granted provided that it is identified as the "RSA Data Security, Inc. MD5 Message-Digest Algorithm" in all material mentioning or referencing this software or this function.

License is also granted to make and use derivative works provided that such works are identified as "derived from the RSA Data Security, Inc. MD5 Message-Digest Algorithm" in all material mentioning or referencing the derived work.

RSA Data Security, Inc. makes no representations concerning either the merchantability of this software or the suitability of this software for any particular purpose. It is provided "as is" without express or implied warranty of any kind.

These notices must be retained in any copies of any part of this documentation and/or software.

# Appendix 8 Operation Examples

[FX5-SSC-S]

This chapter describes the programming procedure and the basic program of the Simple Motion module. When applying the program examples provided in this manual to an actual system, properly verify the applicability and reliability of the control on the system.

[FX5-SSC-G]

For the programming procedure and the basic program of the Motion module, refer to "PROGRAMMING [FX5-SSC-G]" in the following manual.

 MELSEC iQ-F FX5 Motion Module/Simple Motion Module User's Manual (Application)

## Operation example [FX5-SSC-S]

### Overall configuration

The program examples show the programs of the following operations.

- Machine home position return execution
- Execution of 1-axis linear control using axis 1
- JOG operation execution



The following table shows the overall configuration of the positioning control operation examples. Note that the programs in the list are the ones using the axis 1 only.

No.	Program name	Description
1	PLC READY signal ON program	Notifies the Simple Motion module that the CPU module is normal before the start of positioning control.
2	All axis servo ON program	Enables the servo amplifier to operate.
3	Positioning start No. setting program	Sets the positioning data that are executed with a positioning start program. The operation example is the case when the start No. is for machine home position return or the positioning data No.1 of the axis 1 is used.
4	Positioning start program	Starts the machine home position return or the positioning control using positioning data.
5	JOG operation setting program	Sets the JOG operation speed.
6	JOG operation execution program	Starts the JOG operation.

A

### Programming procedure

Take the following steps to create a program for the motion control:

1. Set the system structure setting and parameter setting of the Simple Motion module setting for the initial setting.  
 Page 98 System setting, Page 99 Parameters
2. Set the positioning data of the Simple Motion module setting.  
 Page 99 Positioning data
3. Program examples of each control

## System configuration

The following figure shows the system configuration used for the program examples in this section.

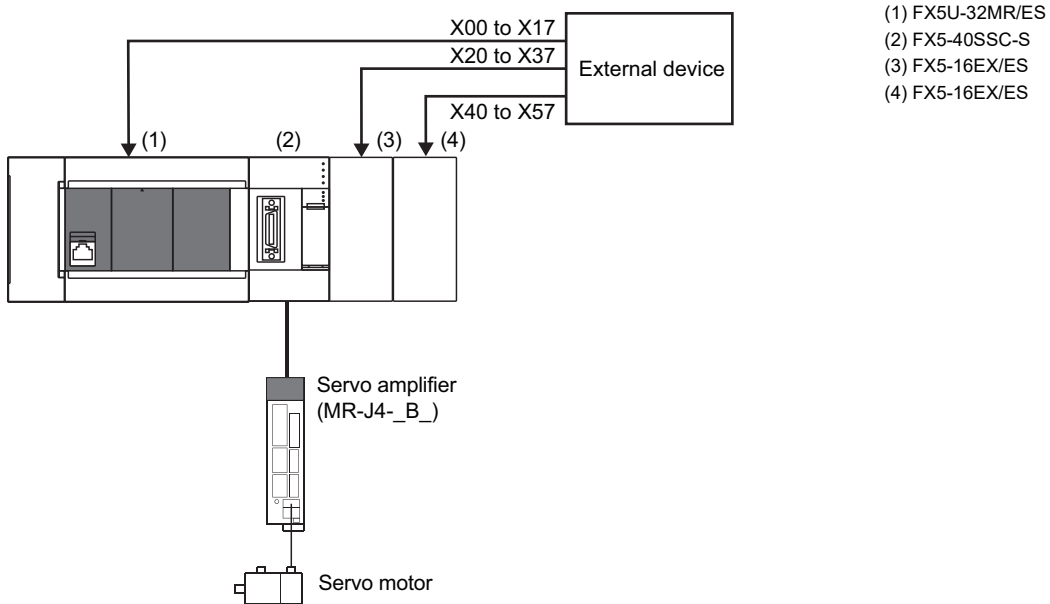

## Initial setting details

Set the system setting, parameters and positioning data using the engineering tool.

### System setting

The system setting is shown below.

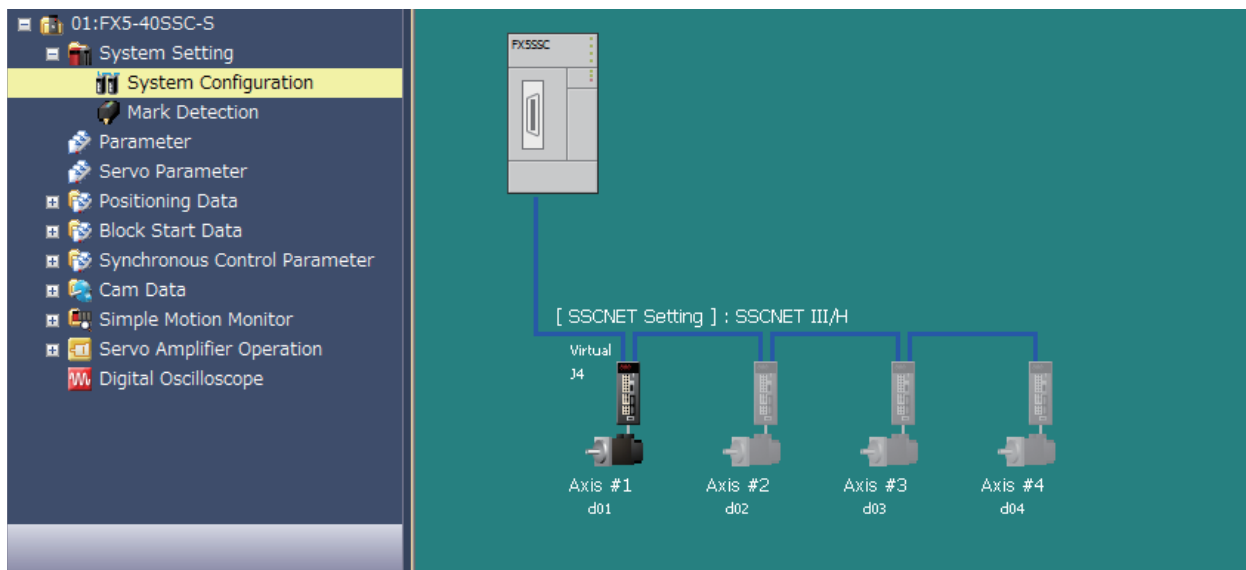

## ■Parameters

The following table lists parameters. Use the default values for the setting items not listed here or the setting items for the axes not described here.

Setting item		Setting value (Axis 1)
Common parameters	[Pr.82] Forced stop valid/invalid selection	1: Invalid
Basic parameters 1	[Pr.1] Unit setting	0: mm
	[Pr.2] Number of pulses per rotation (AP)	4194304 pulses
	[Pr.3] Movement amount per rotation (AL)	250000.0 μm
Detailed parameters 1	[Pr.22] Input signal logic selection: Lower limit	1: Positive logic
	[Pr.22] Input signal logic selection: Upper limit	1: Positive logic
	[Pr.116] FLS signal selection: input type	2(0002h): Buffer memory
	[Pr.117] RLS signal selection: input type	2(0002h): Buffer memory
	[Pr.118] DOG signal selection: input type	2(0002h): Buffer memory
Home position return basic parameters	[Pr.46] Home position return speed	50.00 mm/min
	[Pr.47] Creep speed	15.00 mm/min
	[Pr.48] Home position return retry	1: Retry home position return with limit switch

## ■Positioning data

The following table lists positioning data. Use the default values for the setting items not listed here or the setting items for the axes not described here.

Setting item (Axis 1 Positioning data)	Setting value (Positioning data No.1)	Setting value (Positioning data No.2)	Setting value (Positioning data No.3)
Operation pattern	0: Positioning complete		
Control method	01h: ABS Linear 1 1-axis linear control (ABS)	06h: FWD V/P Speed-position switching control (forward run)	08h: FWD P/V Position-speed switching control (forward run)
Axis to be interpolated	—		
Acceleration time No.	0: 1000		
Deceleration time No.	0: 1000		
Positioning address	-10000.0 μm	2500.0 μm	2000.0 μm
Arc address	—		
Command speed	20.00 mm/min	180.00 mm/min	180.00 mm/min
Dwell time	300 ms	0 ms	300 ms
M code	9843	0	0

## Program Examples Using Labels [FX5-SSC-S]

### List of labels to be used

The following table lists the labels used for the program examples in this section. I/O signals or buffer memory areas of the modules shown in the system configuration are described in the programs using the labels.

For details on the global labels, refer to "LABELS" in the following manual.

 MELSEC iQ-F FX5 Programming Manual (Program Design)

### ■Module label

The following table lists the module labels of the Simple Motion module used for the program examples in this section.

Device name	Device	Label name	Signal name
	Axis 1		
I/O signals	U1\G31500.0	FX5SSC_1.stSysMntr2_D.bReady_D	READY
	U1\G31500.1	FX5SSC_1.stSysMntr2_D.bSynchronizationFlag_D	Synchronization flag
	U1\G31501.0	FX5SSC_1.stSysMntr2_D.bnBusy_D[0]	Axis 1 BUSY signal
	U1\G5950.0	FX5SSC_1.stSysCtrl_D.bPLC_Ready_D	PLC READY
	U1\G5951.0	FX5SSC_1.stSysCtrl_D.bAllAxisServoOn_D	All axis servo ON
Buffer memory	U1\G2417.3	FX5SSC_1.stnAxMntr_D[0].uStatus_D.3	Axis 1 Home position return request flag
	U1\G2417.D	FX5SSC_1.stnAxMntr_D[0].uStatus_D.D	Axis 1 Error detection
	U1\G2417.F	FX5SSC_1.stnAxMntr_D[0].uStatus_D.F	Axis 1 Positioning complete
	U1\G4326	FX5SSC_1.stnAxCtrl1_D[0].udVP_NewMovementAmount_D	Axis 1 Speed-position switching control movement amount change register
	U1\G4328	FX5SSC_1.stnAxCtrl1_D[0].uEnableVP_Switching_D	Axis 1 Speed-position switching enable flag
	U1\G4330	FX5SSC_1.stnAxCtrl1_D[0].udPV_NewSpeed_D	Axis 1 Position-speed switching control speed change register
	U1\G4332	FX5SSC_1.stnAxCtrl1_D[0].uEnablePV_Switching_D	Axis 1 Position-speed switching enable flag

## Global label

The following table lists the global labels, which are created by a user if necessary, used for the program examples in this section. Set the following in the global label of the engineering tool.

- External input (command)

	Label Name	Data Type	Class	Assign (Device/Label)
1	bInputOPRStartReq	Bit	VAR_GLOBAL	X3
2	bInputFastOPRStartReq	Bit	VAR_GLOBAL	X4
3	bInputStartPositioningNoReq	Bit	VAR_GLOBAL	X5
4	bInputSpeedPositionSwitchingReq	Bit	VAR_GLOBAL	X6
5	bInputSpeedPositionSwitchingEnableReq	Bit	VAR_GLOBAL	X7
6	bInputSpeedPositionSwitchingDisableReq	Bit	VAR_GLOBAL	X10
7	bInputChangeSpeedPositionSwitchingMovementAmount	Bit	VAR_GLOBAL	X11
8	bInputStartAdvancedPositioningReq	Bit	VAR_GLOBAL	X12
9	bInputSetJogSpeedReq	Bit	VAR_GLOBAL	X15
10	bInputForwardJogStartReq	Bit	VAR_GLOBAL	X16
11	bInputReverseJogStartReq	Bit	VAR_GLOBAL	X17
12	bInputPositionSpeedSwitchingReq	Bit	VAR_GLOBAL	X40
13	bInputPositionSpeedSwitchingEnableReq	Bit	VAR_GLOBAL	X41
14	bInputPositionSpeedSwitchingDisableReq	Bit	VAR_GLOBAL	X42
15	bInputChangePositionSpeedSwitchingSpeedReq	Bit	VAR_GLOBAL	X43
16	bAllAxisServoOnReq	Bit	VAR_GLOBAL	X57

- Internal relays and data devices (Unused internal relays and data devices are automatically assigned and do not require setting.)

	Label Name	Data Type	Class	Assign (Device/Label)
1	bABRSTReq	Bit	VAR_GLOBAL	
2	bBasicParamSetComp	Bit	VAR_GLOBAL	
3	bDuringJogInchingOperation	Bit	VAR_GLOBAL	
4	bDuringMPGOperation	Bit	VAR_GLOBAL	
5	bFastOPRStartReq	Bit	VAR_GLOBAL	
6	bFastOPRStartReq_H	Bit	VAR_GLOBAL	
7	bInitializeParameterReq	Bit	VAR_GLOBAL	
8	bJOG_bENO	Bit	VAR_GLOBAL	
9	bJOG_bErr	Bit	VAR_GLOBAL	
10	bJOG_bOK	Bit	VAR_GLOBAL	
11	bOPRParamSetComp	Bit	VAR_GLOBAL	
12	bPositioningStartReq	Bit	VAR_GLOBAL	
13	bStartPositioning_bENO	Bit	VAR_GLOBAL	
14	bStartPositioning_bErr	Bit	VAR_GLOBAL	
15	bStartPositioning_bOK	Bit	VAR_GLOBAL	
16	bWriteFlashReq	Bit	VAR_GLOBAL	
17	udJogOperationSpeed	Double Word [Unsigned]/Bit String [32-bit]	VAR_GLOBAL	
18	udMovementAmount	Double Word [Unsigned]/Bit String [32-bit]	VAR_GLOBAL	
19	udSpeed	Double Word [Signed]	VAR_GLOBAL	
20	uInchingMovementAmount	Word [Unsigned]/Bit String [16-bit]	VAR_GLOBAL	
21	uJOG_uErrId	Word [Unsigned]/Bit String [16-bit]	VAR_GLOBAL	
22	uPositioningStartNo	Word [Unsigned]/Bit String [16-bit]	VAR_GLOBAL	
23	uStartPositioning_uErrId	Word [Unsigned]/Bit String [16-bit]	VAR_GLOBAL	



## Program example

The program examples use the module function blocks (FBs) and module labels displayed in "Module POU".

For details on module function blocks, refer to "Simple Motion Module FB/Motion Module FB" in the following manual.

MELSEC iQ-F FX5 Motion Module/Simple Motion Module Function Block Reference

### PLC READY signal ON program

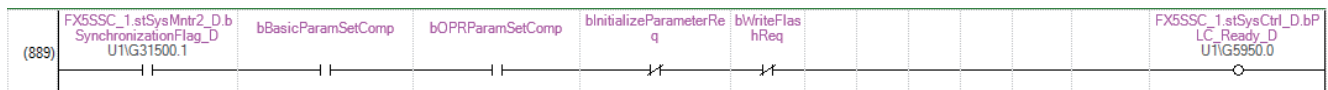

### All axis servo ON program

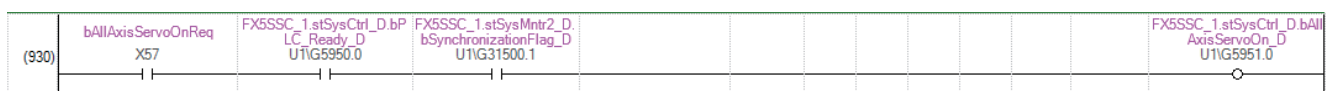



## Positioning start program



## JOG operation setting program

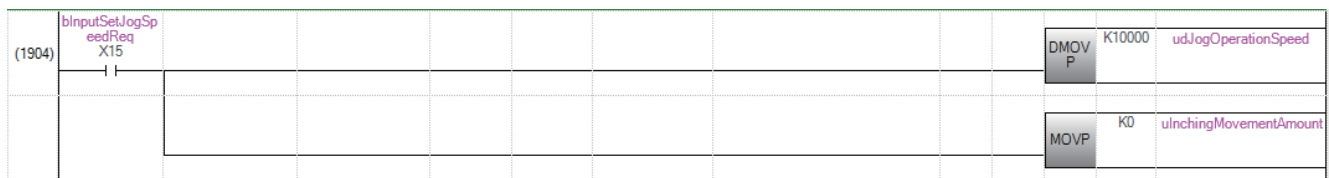

## JOG operation execution program

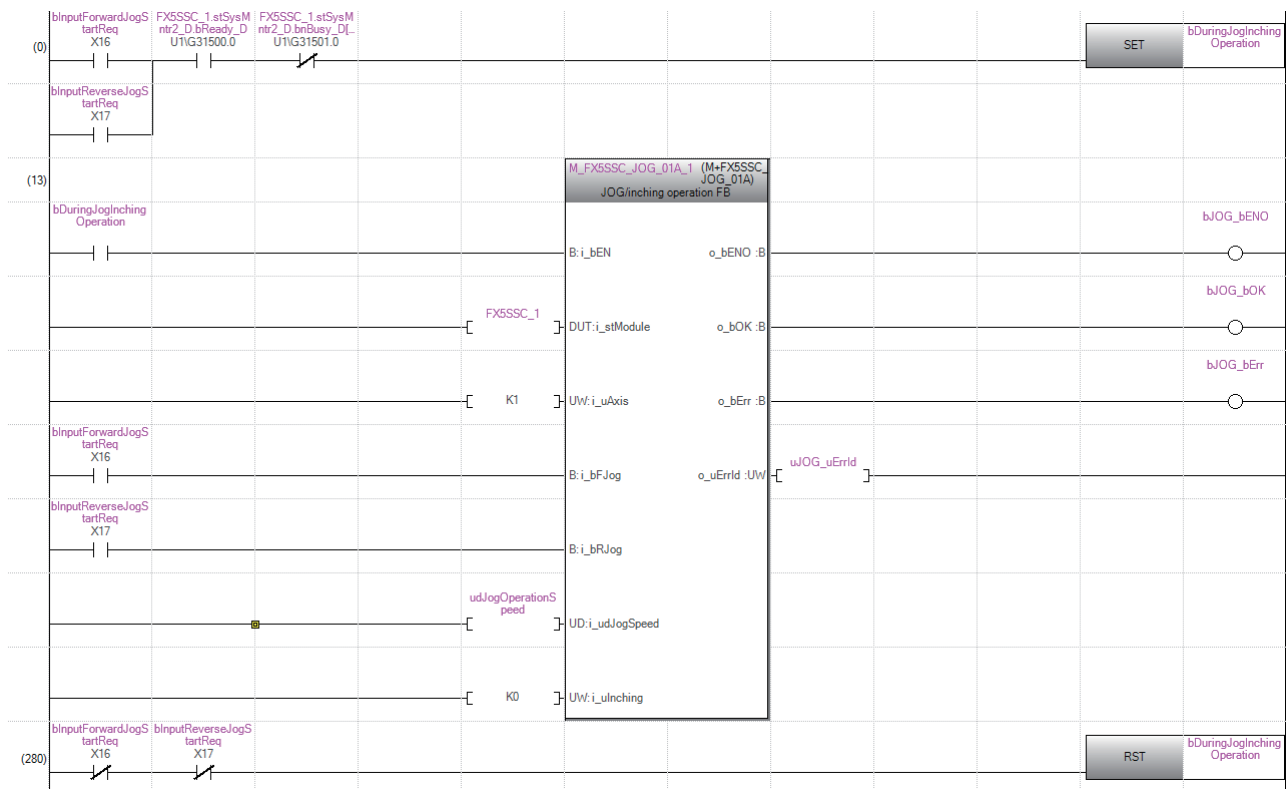

# Program Examples Using Buffer Memory [FX5-SSC-S]

## List of devices to be used

In the program examples, the devices to be used are assigned as follows.

In addition, change the module access device, external inputs, internal relays, data registers, and timers according to the system used.

### ■ Buffer memory address of Simple Motion module, external inputs, internal relay

Device name	Device				Application	Description at device ON
	Axis 1	Axis 2	Axis 3	Axis 4		
Buffer memory address of Simple Motion module	U1\G31500.0				READY signal	READY
	U1\G31500.1				Synchronization flag	Buffer memory accessible
	U1\G2417.C	—			M code ON signal	M code outputting
	U1\G2417.D				Error detection signal	Error detection
	U1\G31501.0				BUSY signal	BUSY (operating)
	U1\G2417.E				Start complete signal	Start completed
	U1\G5950				PLC READY signal	CPU module preparation completed
	U1\G5951			All axis servo ON signal	All axis servo ON signal	
	U1\G30101	—			Forward run JOG start signal	Starting forward run JOG
	U1\G30102				Reverse run JOG start signal	Starting reverse run JOG
	U1\G30104				Positioning start signal	Requesting start
	External input (command)	X3	—			Machine home position return command
X4				Fast home position return command	Commanding fast home position return	
X5				Positioning start command	Commanding positioning start	
X6				Speed-position switching operation command	Commanding speed-position switching operation	
X7				Speed-position switching enable command	Commanding speed-position switching enable	
X10				Speed-position switching prohibit command	Commanding speed-position switching prohibit	
X11				Movement amount change command	Commanding movement amount change	
X12				High-level positioning control start command	Commanding high-level positioning control start	
X15				JOG operation speed setting command	Commanding JOG operation speed setting	
X16				Forward run JOG/inching command	Commanding forward run JOG/inching operation	
X17				Reverse run JOG/inching command	Commanding reverse run JOG/inching operation	
X40				Position-speed switching operation command	Position-speed switching operation command	
X41				Position-speed switching enable command	Position-speed switching enable command	
X42				Position-speed switching prohibit command	Position-speed switching prohibit command	
X43				Speed change command	Speed change command	
X53				PLC READY signal ON	PLC READY signal ON	
X55				For Unit (degree)	For Unit (degree)	
X56				Positioning start signal command	Commanding positioning start	
X57				All axis servo ON command	All axis servo ON command	

Device name	Device				Application	Description at device ON
	Axis 1	Axis 2	Axis 3	Axis 4		
Internal relay	M3	—			Fast home position return command	Commanding fast home position return
	M4				Fast home position return command storage	Fast home position return command held
	M5				Positioning start command pulse	Positioning start commanded
	M6				Positioning start command storage	Positioning start command held
	M7				JOG/inching operation termination	JOG/inching operation termination
	M9				Manual pulse generator operating flag	Manual pulse generator operating flag
	M25				Parameter initialization command storage	Parameter initialization command held
	M27	Flash ROM write command storage	Flash ROM write command held			
	M50	—	Parameter setting complete device	Parameter setting completed		

### ■Data registers and timers

Device name	Device				Application	Storage details
	Axis 1	Axis 2	Axis 3	Axis 4		
Data register	D0	—			Home position return request flag	[Md.31] Status: b3
	D1				Speed (low-order 16 bits)	[Cd.25] Position-speed switching control speed change register
	D3				Movement amount (low-order 16 bits)	[Cd.23] Speed-position switching control movement amount change register
	D5				Inching movement amount	[Cd.16] Inching movement amount
	D6				JOG operation speed (low-order 16 bits)	[Cd.17] JOG speed
	D32				Start No.	—
	Code				U1\G2417	
U1\G4300				Positioning start No.	[Cd.3] Positioning start No.	
U1\G4301				Positioning starting point No.	[Cd.4] Positioning starting point No.	
U1\G4326				Speed-position switching control movement amount	[Cd.23] Speed-position switching control movement amount change register	
U1\G4328				Speed-position switching enable flag	[Cd.24] Speed-position switching enable flag	
U1\G4330				Position-speed switching control speed change	[Cd.25] Position-speed switching control speed change register	
U1\G4332				Position-speed switching enable flag	[Cd.26] Position-speed switching enable flag	



### Program example

#### ■PLC READY signal ON program

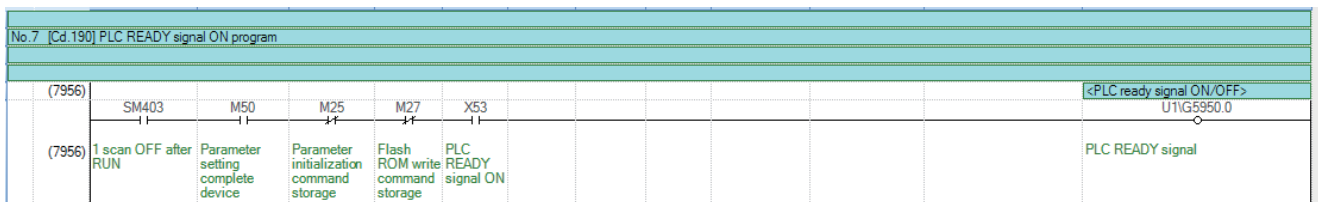

#### ■All axis servo ON program

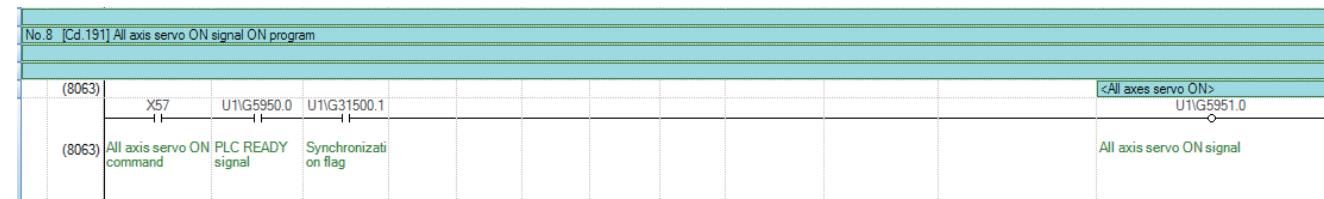

## ■ Positioning start No. setting program

No.9 Positioning start number setting program			
<b>(1) Machine HPR</b>			
(8159)	X3		<Writing Machine HPR (9001)>
(8159)	Machine HPR command	MOV P	K9001 Start number D32
<b>(2) Fast HPR</b>			
(8272)	X4		<Extracting HPR request flag ON/OFF>
(8272)	Fast HPR command	WAND P	U1\G2417 Status H8 D0 HPR request flag
			<Enabling fast HPR start>
		D0 HPR request flag = K0	SET M3 Fast HPR command
			<Writing fast HPR (9002)>
		MOV P	K9002 Start number D32
			<Holding the fast HPR command>
			SET M4 Fast HPR command storage
<b>(3) Positioning with positioning data No. 1</b>			
(8453)	X5		<Positioning data No. 1 setting>
(8453)	Positioning start command	MOV P	K1 Start number D32
<b>(4) Speed-position switching operation (Positioning data No. 2) (In the ABS mode, new movement amount write is not needed.)</b>			
(8513)	X6		<Positioning data No. 2 setting>
(8513)	Speed/position switching operation command	MOV P	K2 Start number D32
(8577)	X7		<Setting speed/position switching signal enable>
(8577)	Speed/position switching enable command	MOV P	K1 U1\G4328 Speed/position switching enable flag
(8641)	X10		<Setting speed/position switching signal prohibit>
(8641)	Speed/position switching prohibit command	MOV P	K0 U1\G4328 Speed/position switching enable flag
(8707)	X11		<Writing movement amount after change>
(8707)	Movement amount change command	DMOV P	D3 Movement amount (low-order 16 bits) U1\G4326 Speed/position switching control movement amount

(5) Position/speed switching operation (positioning data No. 3)						
(8772)	X40 ↓					<Positioning data No.3 setting>
(8772)	Position/speed switching operation command			MOV	K3	D32 Start number
(8831)	X41 ↓	X42 ↓				<Setting position/speed switching signal enable>
(8831)	Position/speed switching enable command	Position/speed switching prohibit command		MOV	K1	U1/G4332 Position/speed switching enable flag
(8897)	X41 ↓	X42 ↓				<Setting position/speed switching signal prohibit>
(8897)	Position/speed switching enable command	Position/speed switching prohibit command		MOV	K0	U1/G4332 Position/speed switching enable flag
(8965)	X43 ↓					<Writing speed after change>
(8965)	Speed change command			DMOV	D1 Speed (low-order 16 bits)	U1/G4330 Position/speed switching control speed change
(6) High-level positioning control						
	X12 ↓					<Writing block positioning (7000)>
(9007)	High-level positioning control start command			MOV	K7000	D32 Start number
						<Writing positioning start point number (1)>
				MOV	K1	U1/G4301 Positioning starting point No.
(7) Fast HPR command and fast HPR command storage OFF (Not required when fast HPR is not used)						
	X3 ↓					<Fast HPR command OFF>
(9127)	Machine HPR command			RST	M3	Fast HPR command
	X5 ↓					<Fast HPR command storage OFF>
	Positioning start command			RST	M4	Fast HPR command storage
	X6 ↓					
	Speed/position switching operation command					
	X40 ↓					
	Position/speed switching operation command					
	X12 ↓					
	High-level positioning control start command					
	M6 ↓					
	Positioning start command storage					



## ■ Positioning start program

No.10 Positioning start program										
(When fast HPR is not performed, contacts of M3 and M4 are not needed.)										
(When M code is not used, contacts of U0.G2417.C are not needed.)										
(When JOG/inching operation is not performed, contacts of M7 are not needed.)										
(When manual pulse generator operation is not performed, contacts of M9 is not needed.)										
(9228)	X56									<Pulse conversion of positioning start command>
(9228)	Positioning start signal command									PLS M5 Positioning start command pulse
<Holding the positioning start command>										
(9356)	Positioning start command pulse	Positioning start signal (axis 1)	Start complete signal (axis 1)	M code ON signal (axis 1)	JOG/inching operation flag	Manual pulse generator operating flag	Fast HPR command			SET M6 Positioning start command storage
							M3	M4		
							Fast HPR command	Fast HPR command storage		
<Positioning start No. setting>										
(9427)	Positioning start command storage									MOV P D32 Start number U1G4300 Positioning start No.
<Executing positioning start>										
										SET U1G30104.0 Positioning start signal (axis 1)
<Positioning start command storage OFF>										
										RST M6 Positioning start command storage
<Positioning start signal OFF>										
(9560)	Positioning start signal (axis 1)	Start complete signal (axis 1)	BUSY signal (axis 1)							RST U1G30104.0 Positioning start signal (axis 1)
		U1G2417.D								
		Error detection signal (axis 1)								

## ■JOG operation setting program

No.12 JOG operation setting program														
									<JOG operation speed (100.00 mm/min) setting>					
(9801)	X15 ↓								<table border="1"> <tr> <td>DMOVP</td> <td>K10000</td> <td>D6</td> <td>JOG operation speed (low-order 16 bits)</td> </tr> </table>	DMOVP	K10000	D6	JOG operation speed (low-order 16 bits)	
DMOVP	K10000	D6	JOG operation speed (low-order 16 bits)											
									<JOG operation speed (1200.000 degrees/min) setting>					
		X55 ↓	For unit (degree)						<table border="1"> <tr> <td>DMOVP</td> <td>K1200000</td> <td>D6</td> <td>JOG operation speed (low-order 16 bits)</td> </tr> </table>	DMOVP	K1200000	D6	JOG operation speed (low-order 16 bits)	
DMOVP	K1200000	D6	JOG operation speed (low-order 16 bits)											
									<Setting the inching movement amount to (0)>					
									<table border="1"> <tr> <td>MOV</td> <td>K0</td> <td>D5</td> <td>Inching movement amount</td> </tr> </table>	MOV	K0	D5	Inching movement amount	
MOV	K0	D5	Inching movement amount											
									<Writing JOG operation speed>					
									<table border="1"> <tr> <td>TOP</td> <td>H1</td> <td>K4317</td> <td>D5 Inching movement amount</td> <td>K3</td> </tr> </table>	TOP	H1	K4317	D5 Inching movement amount	K3
TOP	H1	K4317	D5 Inching movement amount	K3										

## ■JOG operation execution program

No.14 JOG operation/inching operation execution program												
									<JOG/inching operation flag ON>			
(10240)	X16 ↓	U1G31500.0 READY signal	U1G31501.0 BUSY signal (axis 1)						<table border="1"> <tr> <td>SET</td> <td>M7</td> <td>JOG/inching operation flag</td> </tr> </table>	SET	M7	JOG/inching operation flag
SET	M7	JOG/inching operation flag										
	X17 ↓											
(10363)									<JOG/inching operation end>			
(10363)	X16 ↓	X17 ↓							<table border="1"> <tr> <td>RST</td> <td>M7</td> <td>JOG/inching operation flag</td> </tr> </table>	RST	M7	JOG/inching operation flag
RST	M7	JOG/inching operation flag										
(10402)									<Executing forward run JOG/inching operation>			
(10402)	X16 ↓	M7 ↓	U1G30102.0 Reverse run JOG start signal (axis 1)						<table border="1"> <tr> <td>U1G30101.0</td> <td>Forward run JOG start signal (axis 1)</td> </tr> </table>	U1G30101.0	Forward run JOG start signal (axis 1)	
U1G30101.0	Forward run JOG start signal (axis 1)											
(10465)									<Executing reverse run JOG/inching operation>			
(10465)	X17 ↓	M7 ↓	U1G30101.0 Forward run JOG start signal (axis 1)						<table border="1"> <tr> <td>U1G30102.0</td> <td>Reverse run JOG start signal (axis 1)</td> </tr> </table>	U1G30102.0	Reverse run JOG start signal (axis 1)	
U1G30102.0	Reverse run JOG start signal (axis 1)											



# Appendix 9 Setting Example for Motion Modules [FX5-SSC-G]

This section describes the setting procedure all the way up to servo ON when combining the Motion module and servo amplifier MR-J5(W)-G.

The construction method of the program is the same as for the Simple Motion module.

## Preparation

### ■Preparing the module/engineering tool and checking the version

Category		Model	Compatible version
Module	CPU module	FX5U FX5UC	Version 1.230 or later
	Motion module	FX5-40SSC-G FX5-80SSC-G	No restriction
	Servo amplifier	MR-J5(W)-G	Version B2 or later
Engineering tool	PLC software package	GX Works3	Version 1.072A or later
	Servo set-up software	MR Configurator2	Version 1.120A or later <sup>*1</sup>

\*1 MR Configurator2 version 1.120A is not included in GX Works3 version 1.072A. For details, contact your local sales representative.

### ■System configuration

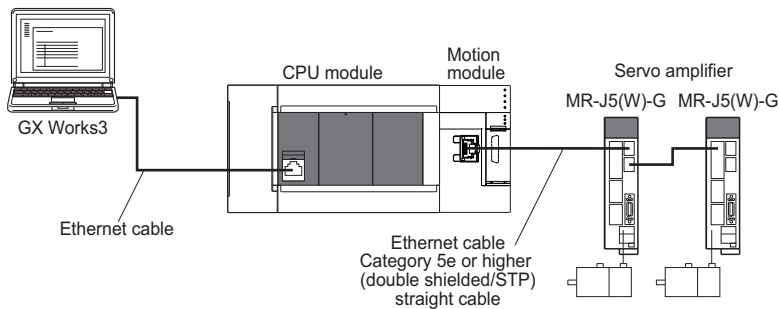

## Project creation

- Starting GX Works3.
  - Start GX Works3.
- Creating a new project.
  - Create a new project.

[Project] ⇒ [New]

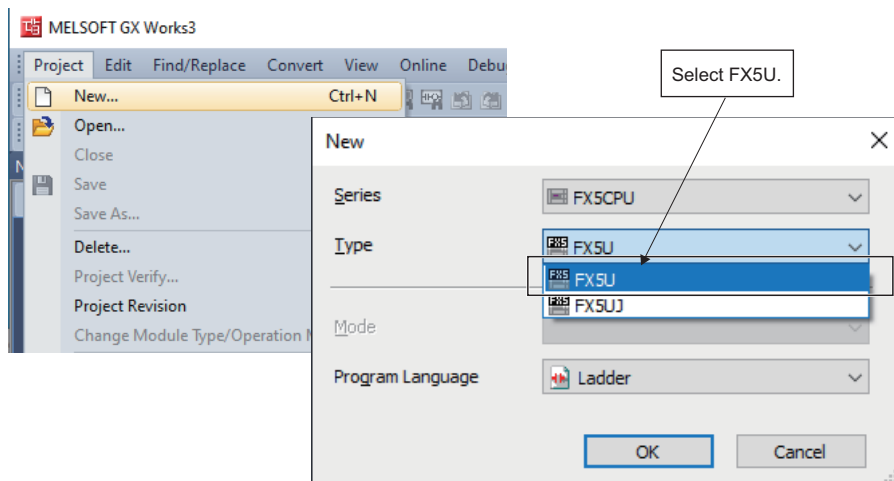

\*The Motion module cannot be used with FX5UJ.

## System configuration setting

### ■ Adding a module

- In the Element Selection window of the module configuration, select the Motion module to be used and drag and drop it.

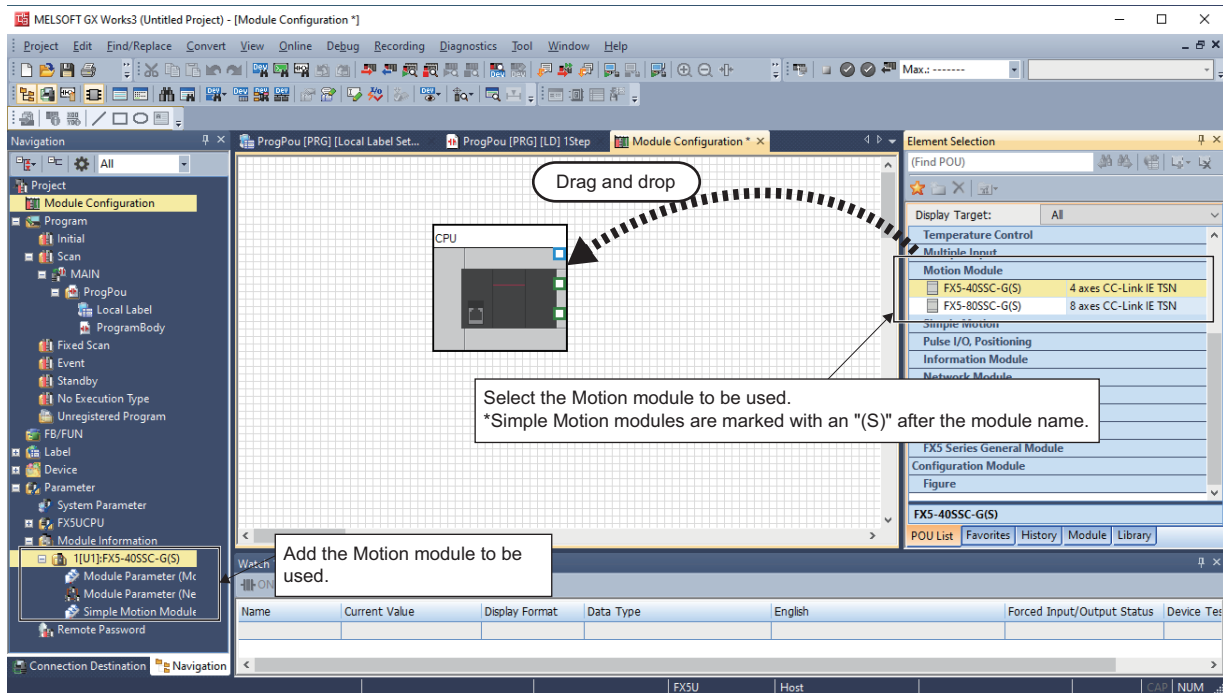

### ■ Network parameter setting

- Open the parameter setting screen and set the servo amplifier to be used and the servo parameters.

Double click Navigation window ⇒ "Parameter" ⇒ "Module Information" ⇒ Target module ⇒ "Module Parameter (Network)"

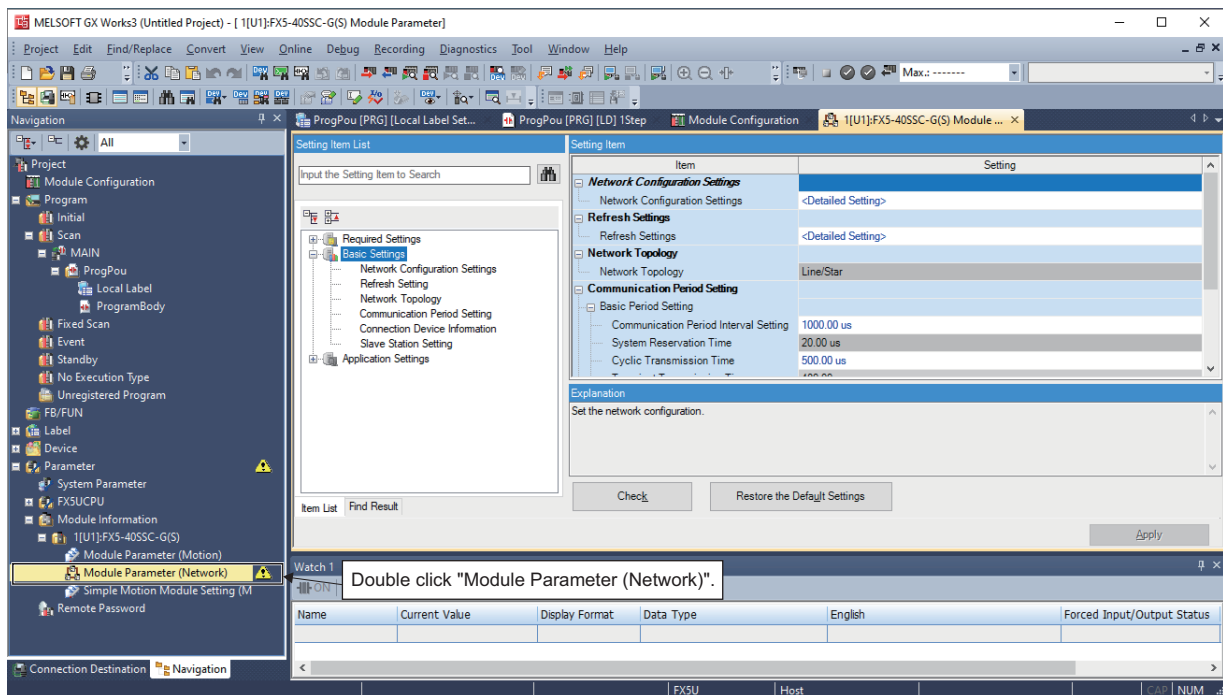

A



## ■PDO mapping setting

- When using a Motion module, PDO mapping setting is not required as the PDO mapping is fixed to the external signal of the servo amplifier.

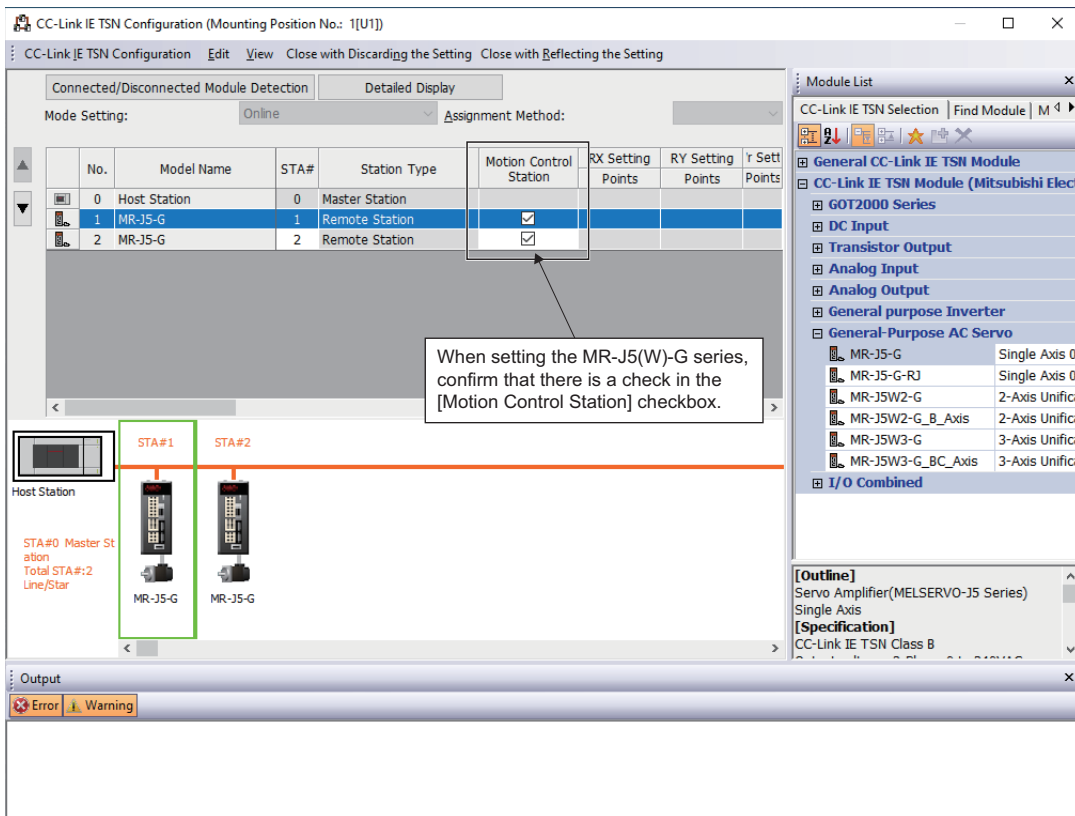

## ■Servo parameter setting

- Set the servo parameters. For the setting details, refer to the following.  
 ➔ Page 114 Servo parameter setting value when using MR-J5(W)-G

🖱️ Double click the servo amplifier icon or <Detail Setting> in "Parameter Automatic Setting"

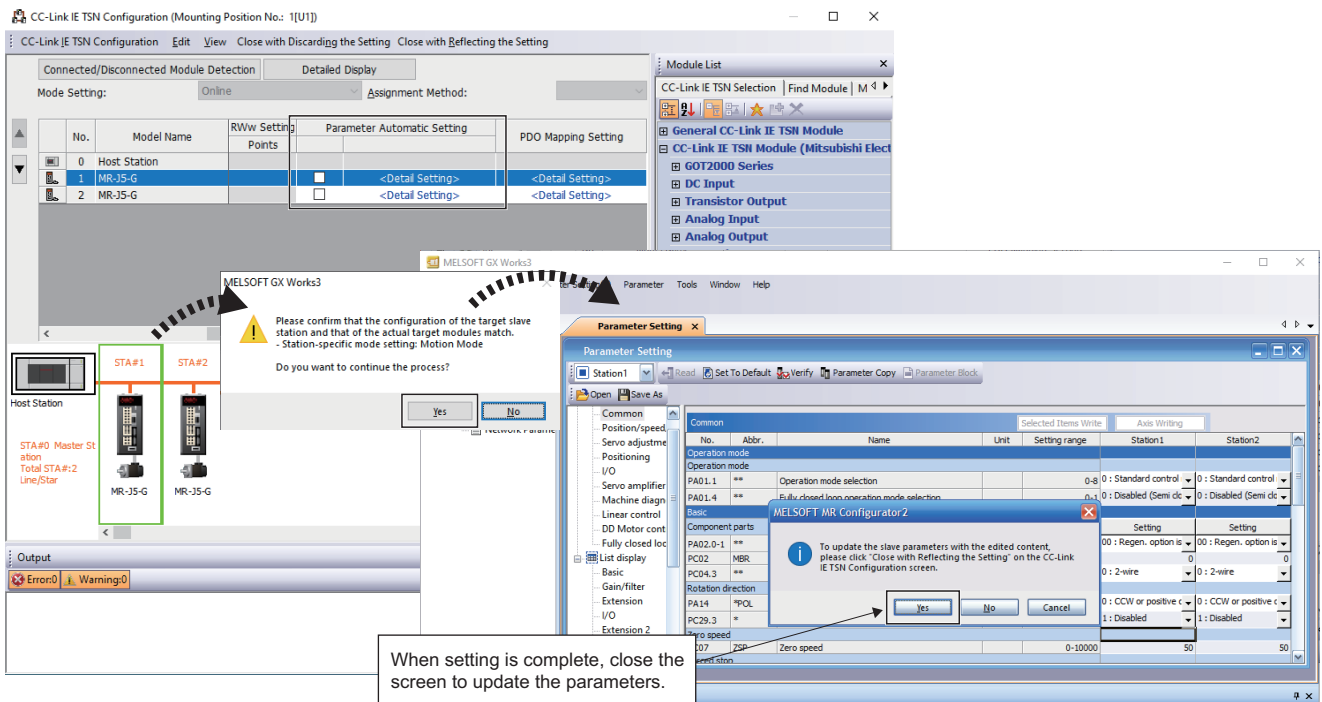

## ■ Servo parameter setting value when using MR-J5(W)-G

Set the parameters of MR-J5(W)-G as shown below when executing motion control with MR-J5(W)-G. When the parameters are not set as shown below, the error "Servo parameter invalid" (error code: 1DC8H) occurs and the values will be rewritten from the Motion module.

When an error occurs, reset said error after resetting the Motion module or MR-J5(W)-G.

No.	Name	Default value	Setting value
PA06	Electronic gear numerator <sup>*1</sup>	1	<ul style="list-style-type: none"> <li>When using the rotary servo motor HK-KT series: 16</li> <li>Other (when not using the rotary servo motor HK-KT series): 1</li> </ul>
PA07	Electronic gear denominator <sup>*1</sup>	1	1
PC79.0	DI status read selection <sup>*1</sup>	0h	Eh bit1: Returns the on/off state of DI1 pin. bit2: Returns the on/off state of DI2 pin. bit3: Returns the on/off state of DI3 pin.
PD41.2	Limit switch enabled status selection <sup>*1</sup>	0h	1h (only enabled in homing mode)
PD41.3	Sensor input method selection <sup>*1</sup>	0h	1h (Input from controller (C_FLS/C_RLS/C_DOG))
PD60	DI pin polarity selection <sup>*1</sup>	0h	0h bit0: DI pin polarity selection 1 (ON with 24 V input) bit1: DI pin polarity selection 2 (ON with 24 V input) bit2: DI pin polarity selection 3 (ON with 24 V input)
PT01.1	Speed/acceleration/deceleration unit selection <sup>*2</sup>	0h	0h
PT08	Homing position data <sup>*1</sup>	0	0h
PT15	Software position limit +	0	0
PT17	Software position limit -	0	0
PT29.0	Device input polarity 1 <sup>*1</sup>	0h	1h: Dog detection with on

\*1 The parameter is enabled after resetting the Motion module or MR-J5(W)-G.

\*2 The parameter is enabled after resetting the MR-J5(W)-G.

## ■ Reflecting the network configuration setting

Place a check in the checkbox in "Parameter Automatic Setting".

## ■Applying the operation cycle setting and module parameters

The operation cycle is set in "Communication Period Interval Setting" of "Communication Period Setting".

Click [Apply] to apply the settings in Module Parameters (Network).

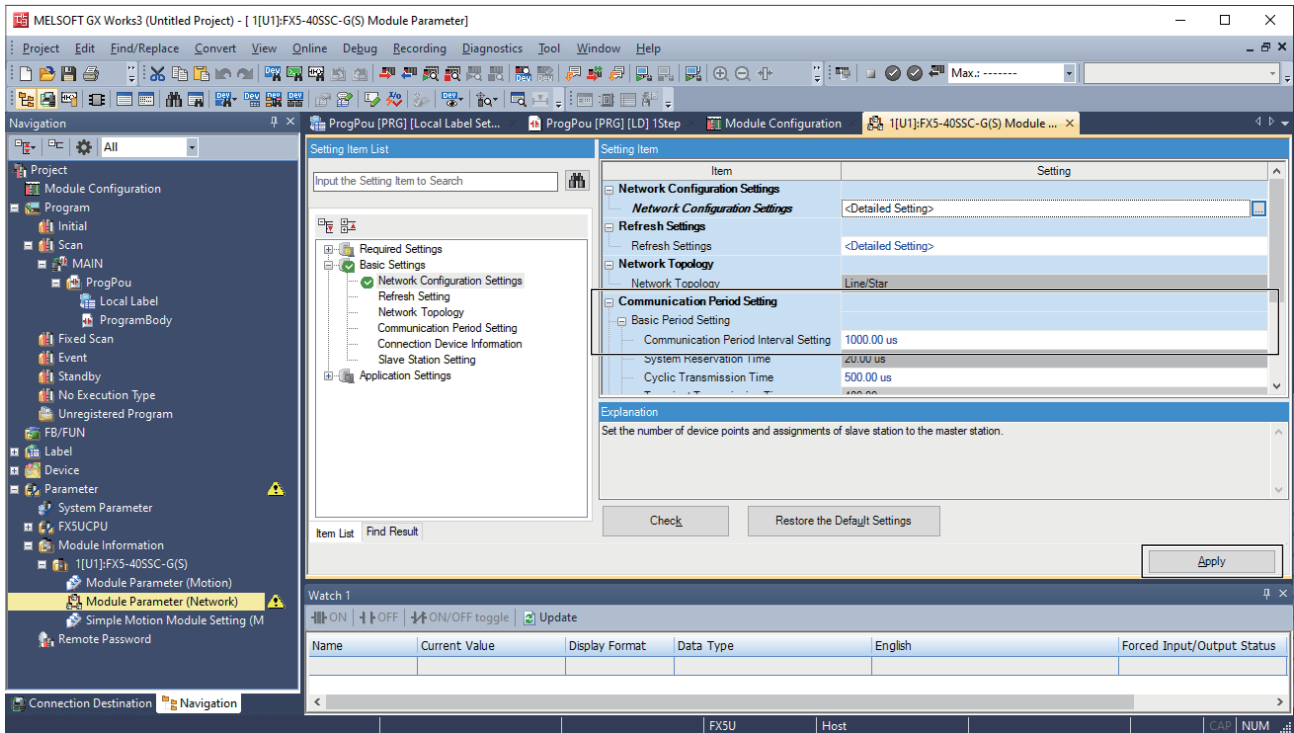

## Simple Motion Module Setting

### ■Starting the Simple Motion Module Setting

Start the Simple Motion Module Setting screen.

🖱️ Double click Navigation window ⇒ "Parameter" ⇒ "Module Information" ⇒ Target module ⇒ "Simple Motion Module Setting (Module Extended Parameter)"

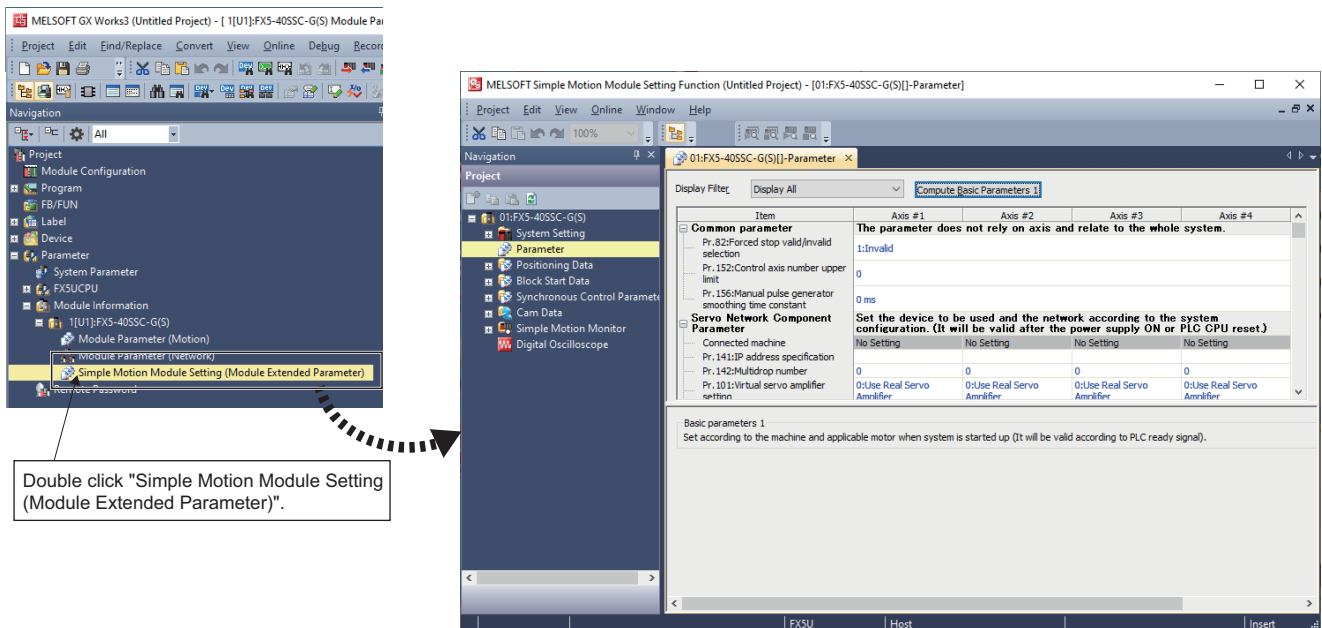

Double click "Simple Motion Module Setting (Module Extended Parameter)".



## ■Setting the axis

Set the servo network configuration parameters "[Pr.141] IP address specification" and "[Pr.142] Multidrop number".

In general, set parameters related to the servo amplifier on the GX Works3 side in the same way as for FX5-SSC-S.

The IP address set in the CC-Link IE TSN configuration can be selected (same as for Motion Control Setting).

Displays the servo amplifier corresponding to the IP address.

Item	Axis #1	Axis #2
Pr.152:Control axis number upper limit	0	0
Pr.156:Manual pulse generator setting	0 ms	0 ms
<b>Servo Network Component Parameter</b>		
Set the device to be used and the network according to the machine and applicable motor when system is started up (It will be valid after the power supply ON or PLC CPU reset).		
Connected machine	MR-J5-G	MR-J5-G
Pr.141:IP address specification	192.168.3.1	192.168.3.1
Pr.142:Multidrop number	0	0
<b>Basic parameters 1</b>		
Set according to the machine and applicable motor when system is started up (It will be valid after the power supply ON or PLC CPU reset).		
Pr.1:Unit setting	0:mm	0:mm
Pr.2:Number of pulses per rotation	4194304 pulse	4194304 pulse
Pr.3:Movement amount per rotation	2000.0 μm	2000.0 μm
Pr.4:Unit magnification	1:x1 Times	1:x1 Times
Pr.7:Bias speed at start	0.00 mm/min	0.00 mm/min

## ■Setting the electronic gear

- When using a rotary MR-J5(W)-G motor, set the resolution of the electronic gear to the MR-J4(W)-B motor resolution (22 bit, or 4194304 pulse) instead of 26 bit (67108864 pulse).

The Motion module automatically overwrites the electronic gear of the servo amplifier parameters. For details, refer to the following.

☞ Page 114 Servo parameter setting value when using MR-J5(W)-G

Item	Axis #1	Axis #2
Pr.152:Control axis number upper limit	0	0
Pr.156:Manual pulse generator sm...	0 ms	0 ms
<b>Servo Network Component Par...</b>		
Set the device to be used and the network according to the machine and applicable motor when system is started up (It will be valid after the power supply ON or PLC CPU reset).		
Connected machine	MR-J5-G	MR-J5-G
Pr.141:IP address specification	192.168.3.1	192.168.3.1
Pr.142:Multidrop number	0	0
Pr.101:Virtual servo amplifier setting	0:Use Real Servo Am...	0:Use Real Servo Am...
Pr.140:Driver command discard de...	1:Detection Valid	1:Detection Valid
<b>Basic parameters 1</b>		
Set according to the machine and applicable motor when system is started up (It will be valid after the power supply ON or PLC CPU reset).		
Pr.1:Unit setting	0:mm	0:mm
Pr.2:Number of pulses per rotation	4194304 pulse	4194304 pulse
Pr.3:Movement amount per rotation	2000.0 μm	2000.0 μm
Pr.4:Unit magnification	1:x1 Times	1:x1 Times
Pr.7:Bias speed at start	0.00 mm/min	0.00 mm/min

Connected machine  
Axes can be set with Module Parameter (Network).  
Please set the CC IE TSN Configuration by selecting Module Parameter (Network) - Basic Settings

- The basic position information per rotation for the servo amplifier is 26 bit (67108864 pulse).

MELSOFT MR Configurator2 New project

Project View Display All(2) Parameter Safety Postlogging-data Monitor Diagnosis Test Mode Adjustment Tools Window Help

Project New project

System Setting

- Axis1:MR-JS-G(-)
- Parameter
- Network Para
- Safety Param
- Point Table
- Axis2:MR-JS-G(-)
- Parameter
- Network Para
- Safety Param

Servo Assistant

Assistant List

Servo Startup Procedure

step1 Servo Amp Servo Motor

step2 Machine

Step 1: Amplifier Setting

Amplifier Setting

Step 2: Test Run

Test Run

Step 3: Servo Adjustments

Servo Adjustments

Maintenance of the Servo Amplifier Parts

Maintenance

If a Problem Occurs

Troubleshooting

Alarm Display Display All

No.	Item	Unit	Axis1	Axis2
1	Cumulative feedback pulses	pulse	63679	23465
2	Servo motor speed	r/min, m	0	0
3	Droop pulse	pulse	-1	2
4	Cumulative cmd. pulses	pulse	-270	139
5	Command pulse frequency	kpulse/s	0	0
6	Regenerative load ratio	%	0	0
7	Effective load ratio	%	0	0
8	Peak load ratio	%	0	0
9	Torque/Instantaneous torque	%	0	0
10	Within one-revolution position	pulse	17613714	40666003
11	ABS counter	rev	-16005	-153
12	Load inertia moment ratio	times	0.62	2.76
13	Bus voltage	V	286	287
14	Load side encoder cumulative F/B pulses	pulse	0	0
15	Load side droop pulses	pulse	0	0
16	Load side encoder information 1		17613714	40666003
17	Load side encoder information 2		-16005	-153
18	Servo motor thermistor temperature	°C	9999	9999
19	Cumulative feedback pulses (Motor unit)	pulse	63679	23465
20	Electrical angle	pulse	17613651	40665964
21	Servo motor/load side position difference	pulse	0	0
22	Servo motor/load side speed difference	r/min	0	0
23	Internal temperature of encoder	°C	39	39
24	Settling time	ms	0	0
25	Oscillation detection frequency	Hz	0	0
26	Number of tough drive operations	times	0	0
27	Unit power consumption	W	12	12
28	Unit total power consumption	Wh	1	1

Expansion parameters	Set according to the system configurat...	
Pr.91:Optional data monitor : Data type setting 1	H2B12:Load Side Encoder Information ...	H2B12:Load Side Encoder Information ...
Pr.91:Optional data monitor : Data type expansion setting 1	H0020	H0020
Pr.92:Optional data monitor : Data type setting 2	0:No Setting	0:No Setting
Pr.92:Optional data monitor : Data type expansion setting 2	H0000	H0000

When "Load Side Encoder Information" is retrieved in the optional data monitor.

01-FX5-SSC-G(S) - Axis Monitor

Axis Monitor Monitor Type: Axis(Output Axis) Font Size: 9pt

(\* Please check the Event History function of GX Works3 for the Error History/Warning History.

	Axis #1	Axis #2
Md.20:Feed current value	16 pulse	8 pulse
Md.21:Machine feed value	16 pulse	8 pulse
Md.22:Axis error No.	-	-
Md.24:Axis warning No.	-	-
Md.26:Axis operation status	Waiting	Waiting
Md.28:Axis feed speed	0 pulse/s	0 pulse/s
Md.44:Positioning data No. being executed	-	-
Md.47:Positioning data being executed : Operation pattern	Positioning Complete	Positioning Complete
Md.47:Positioning data being executed : Control method	-	-
Md.47:Positioning data being executed : Acceleration time No.	0:1000	0:1000
Md.47:Positioning data being executed : Deceleration time No.	0:1000	0:1000
Md.47:Positioning data being executed : Axis to be interpolated	-	-
Md.47:Positioning data being executed : Hic code	-	-
Md.102:Deviation counter	0 pulse	-3 pulse
Md.103:Motor rotation speed	-0.67 r/min	0.07 r/min
Md.104:Motor current value	0.1 %	0.1 %
Md.108:Servo status 1 : Servo alarm	OFF	OFF
Md.108:Servo status 1 : Servo warning	OFF	OFF
Pr.91:Optional data monitor output 1	17838575	40765718
Pr.92:Optional data monitor output 2	-	-

## Program

The Motion module performs control with the buffer memory instead of using the XY signal for the PLC READY, servo ON command, and start command. In addition, the I/O No. starts from 1. In the program below, PLC READY of Start I/O No. 1 Motion module is turned ON and the servo ON of the axis used can be executed.

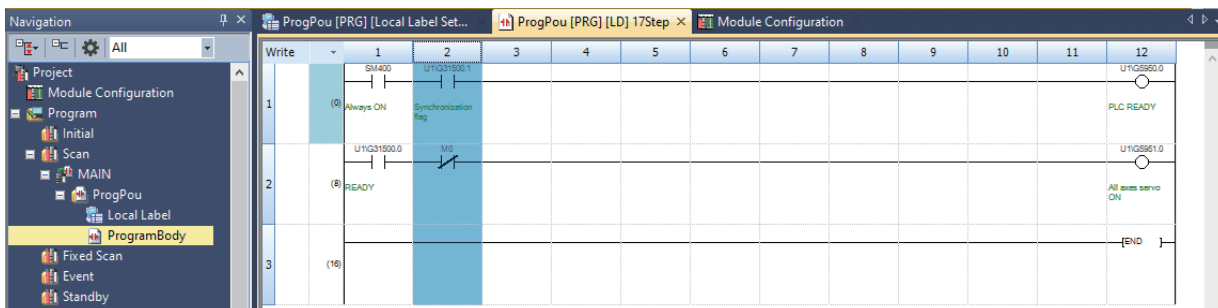

A

## Writing/reading of data

Data, including data set in the Simple Motion Module Setting, is written/read from GX Works3.

However, the initial writing/reading of Simple Motion Module Setting data should be performed after first writing module parameters set with the Motion module to the CPU module.

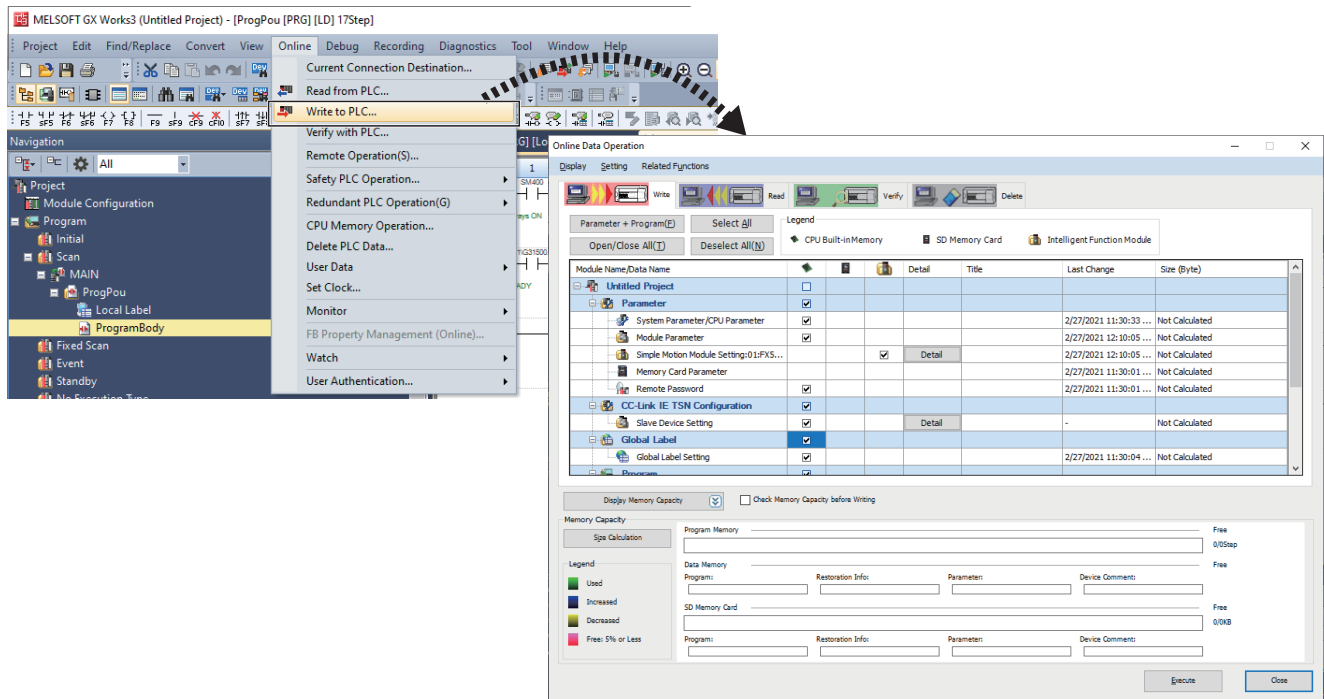

## Precautions

- When using an HK-KT motor as a serial ABS synchronous encoder while said motor is connected to the MR-J5-B-RJ, the resolution becomes 67108864 (pulse/rev). As such, it is necessary to adjust "[Pr.322] Synchronous encoder axis unit conversion: Numerator" and "[Pr.323] Synchronous encoder axis unit conversion: Denominator" when processing cannot be changed with the Q171ENC-W8.

Unit conversion	
Pr.322:Numerator	1 pulse
Pr.323:Denominator	16 pulse

- To perform mark detection for an axis performing dog method home position return, etc. with the input signal of the servo amplifier, it is necessary to either perform mark detection using the DOG signal of an axis not performing home position return, or use the home position return DOG signal via the buffer memory.
- When the error "Servo parameter invalid" (error code: 1DC8H) occurs, the error state is cleared when the Motion module is restarted or the servo amplifier is turned OFF and ON. To reflect changes made to parameters in a project, reopen the servo parameter setting screen and apply the servo parameters to the project by directly reading said parameters from the servo amplifier via "Read".

For the FX5CPU, "Automatic update of saved parameters" is not supported by parameter automatic saving setting of the device stations. Note that the servo parameters are not changed even if device settings are read from the CPU module.

Initial value	Setting range	Setting method	Ver.
00003000h		Each axis	Refer to the relevant detail No.

- Turning off the power supply of the servo amplifier while changing servo parameters to the recommended setting may cause the servo parameters to become corrupted. Turn off the power supply of the servo amplifier after confirming that the Motion module is on one of the following states.

- The error "Servo parameter invalid" (error code: 1DC8H) occurs
- "[Md.190] Controller position value restoration request" is "1: Complete INC restoration" or "2: Complete ABS restoration"



# INDEX

---

## A

---

Absolute position system . . . . .	49
Acceleration/deceleration processing function . . .	49
Acceleration/deceleration time change function . .	49
Amplifier-less operation function . . . . .	51
Applicable wire size . . . . .	26

## B

---

Backlash compensation function . . . . .	49
Block start (Normal start) . . . . .	47

## C

---

Combination of Main Functions and Sub Functions . . . . .	52
Command in-position function . . . . .	49
Common (COM) . . . . .	74
Common functions . . . . .	51
Component List . . . . .	77
Condition start . . . . .	47
Connect/disconnect function of SSCNET communication . . . . .	51
Connection with External Devices . . . . .	86
Continuous operation interrupt function . . . . .	49
Continuous path control . . . . .	48
Continuous positioning control . . . . .	48
Current value changing . . . . .	47

## D

---

Deceleration start flag function . . . . .	50
Driver communication function . . . . .	51

## E

---

Electronic gear function . . . . .	49
Event history function . . . . .	51
Execution data backup function . . . . .	51
Expansion control . . . . .	46
External Dimensions . . . . .	91
External input signal select function . . . . .	51
External input wiring connector . . . . .	26

## F

---

Fast home position return control . . . . .	47
Firmware update function . . . . .	51
Fixed-feed control . . . . .	47
Follow up function . . . . .	50
Forced stop function . . . . .	49
Forced stop input signal (EMI) . . . . .	74
Forced stop input signal common (EMI.COM) . . .	74

## H

---

Hardware stroke limit function . . . . .	49
High-level positioning control . . . . .	46
History monitor function . . . . .	51
Home position return control . . . . .	46
Home position return retry function . . . . .	49

Home position shift function . . . . .	49
Hot line forced stop function . . . . .	51

## I

---

Inching operation . . . . .	47
Independent positioning control (positioning complete) . . . . .	48
internal circuit . . . . .	74

## J

---

JOG operation . . . . .	47
JUMP instruction . . . . .	47

## L

---

LEND . . . . .	47
Linear control . . . . .	47
Link device external signal assignment function . .	51
LOOP . . . . .	47

## M

---

M code output function . . . . .	49
Machine home position return control . . . . .	47
Major positioning control . . . . .	46
Manual control . . . . .	46
Manual pulse generator operation . . . . .	47
Manual pulse generator/Incremental synchronous encoder A-phase/PULSE . . . . .	73
Manual pulse generator/Incremental synchronous encoder B-phase/SIGN . . . . .	73
Mark detection function . . . . .	51
Mass . . . . .	26

## N

---

Near pass function . . . . .	49
NOP instruction . . . . .	47
Number of controlled axes . . . . .	25
Number of occupied I/O points . . . . .	26

## O

---

Operation Examples . . . . .	97
Operation setting for incompleteness of home position return function . . . . .	50
Optional data monitor function . . . . .	51
Override function . . . . .	49

## P

---

Parameter initialization function . . . . .	51
Performance Specifications . . . . .	25
Position-speed switching control . . . . .	47
Pre-reading start function . . . . .	49

## R

---

Repeated start (FOR condition) . . . . .	47
--	----

Repeated start (FOR loop) . . . . . 47

## S

---

Servo transient transmission function . . . . . 51  
Signal ground (SG) . . . . . 74  
Simultaneous start . . . . . 47  
Skip function . . . . . 49  
Software stroke limit function . . . . . 49  
Speed change function . . . . . 49  
Speed control 10 times multiplier setting for degree  
axis function . . . . . 50  
Speed limit function . . . . . 49  
Speed-position switching control . . . . . 47  
Speed-torque control . . . . . 48  
Step function . . . . . 49  
Stop command processing for deceleration stop  
function . . . . . 49  
Sub functions . . . . . 49  
Synchronous control . . . . . 48

## T

---

Target position change function . . . . . 49  
Teaching function . . . . . 49  
Torque change function . . . . . 49  
Torque limit function . . . . . 49

## V

---

Virtual servo amplifier function . . . . . 51

## W

---

Wait start . . . . . 47



# REVISIONS

\*The manual number is given on the bottom left of the back cover.

Revision date	*Manual number	Description
November 2014	IB(NA)-0300251ENG-A	First edition
January 2015	IB(NA)-0300251ENG-B	<ul style="list-style-type: none"> <li>■ Added or modified parts</li> </ul> SAFETY PRECAUTIONS, RELEVANT MANUALS, TERMS, Section 2.5, 3.1, 3.4, Chapter 4, Section 5.1, 5.2, Chapter 6, Appendix 2
August 2015	IB(NA)-0300251ENG-C	<ul style="list-style-type: none"> <li>■ Added functions</li> <li>Command generation axis</li> <li>■ Added or modified parts</li> </ul> Section 1.1, 2.3, 3.2, Chapter 6
October 2016	IB(NA)-0300251ENG-D	<ul style="list-style-type: none"> <li>■ Added models</li> <li>FX5-80SSC-S</li> <li>■ Added functions</li> <li>Inverter FR-A800 series, Stepping motor driver AlphaStep/5-phase manufactured by ORIENTAL MOTOR Co., Ltd., Servo driver VCI series/VPH series manufactured by CKD NIKKI DENSO CO., LTD., IAI electric actuator controller manufactured by IAI Corporation</li> <li>■ Added or modified parts</li> </ul> SAFETY PRECAUTIONS, INTRODUCTION, TERMS, PERIPHERALS, Chapter 1, Section 1.1, Chapter 2, Section 2.3, 2.4, 2.5, 3.1, Chapter 4, Section 5.1, 5.2, Chapter 6, Section 6.1, 6.2, Appendix 1, 2, 3, 4, WARRANTY
March 2021	IB(NA)-0300251ENG-E	<ul style="list-style-type: none"> <li>■ Added models</li> <li>FX5-40SSC-G, FX5-80SSC-G</li> <li>■ Added or modified parts</li> </ul> WHEN USING A SWITCHING HUB WITH CC-LINK IE TSN, SAFETY PRECAUTIONS, INTRODUCTION, RELEVANT MANUALS, TERMS, PERIPHERALS, Chapter 1, Section 1.1, Chapter 2, Section 2.1, 2.2, 2.3, 2.4, 2.5, Chapter 3, Section 3.1, 3.2, 3.3, Chapter 4, Section 5.1, 5.2, 5.3, 5.4, 5.5, Appendix 1, 2, 3, 4, 5, 6, 7, 8, 9, WARRANTY, TRADEMARKS
March 2021	IB(NA)-0300251ENG-F	<ul style="list-style-type: none"> <li>■ Added or modified parts</li> </ul> Section 2.5
December 2021	IB(NA)-0300251ENG-G	<ul style="list-style-type: none"> <li>■ Added or modified parts</li> </ul> SAFETY PRECAUTIONS, RELEVANT MANUALS, TERMS, PERIPHERALS, Chapter 1, Section 2.4, 2.5, Section 3.2, Chapter 4, Section 5.2, 5.5, Appendix 1, 4, 5, 6, 9
July 2022	IB(NA)-0300251ENG-H	<ul style="list-style-type: none"> <li>■ Added or modified parts</li> </ul> SAFETY PRECAUTIONS, RELEVANT MANUALS, TERMS, GENERIC TERMS AND ABBREVIATIONS, PERIPHERALS, Section 3.1, Chapter 4, Section 5.1, 5.2, Appendix 1, 2, 3, 6, 7, 9, INDEX
November 2023	IB(NA)-0300251ENG-J	<ul style="list-style-type: none"> <li>■ Added or modified parts</li> </ul> SAFETY PRECAUTIONS, RELEVANT MANUALS, TERMS, GENERIC TERMS AND ABBREVIATIONS, Section 1.1, 2.2, 2.5, Chapter 3, Section 3.1, 3.2, 5.2, 5.4, Appendix 3, 6, 9, INFORMATION AND SERVICES, TRADEMARKS
July 2024	IB(NA)-0300251ENG-K	<ul style="list-style-type: none"> <li>■ Added or modified parts</li> </ul> SAFETY PRECAUTIONS, TERMS, GENERIC TERMS AND ABBREVIATIONS, Section 2.5, 3.1, Appendix 9
November 2024	IB(NA)-0300251ENG-L	<ul style="list-style-type: none"> <li>■ Added or modified parts</li> </ul> SAFETY PRECAUTIONS, RELEVANT MANUALS, TERMS, GENERIC TERMS AND ABBREVIATIONS, Section 3.1, 5.2, TRADEMARKS
February 2026	IB(NA)-0300251ENG-M	<ul style="list-style-type: none"> <li>■ Added or modified parts</li> </ul> SAFETY PRECAUTIONS, TERMS, GENERIC TERMS AND ABBREVIATIONS, PERIPHERALS, Chapter 1, Section 3.1, Appendix 1

Japanese manual number: IB-0300250-K

This manual confers no industrial property rights or any rights of any other kind, nor does it confer any patent licenses. Mitsubishi Electric Corporation cannot be held responsible for any problems involving industrial property rights which may occur as a result of using the contents noted in this manual.

©2014 MITSUBISHI ELECTRIC CORPORATION

# WARRANTY

Please confirm the following product warranty details before using this product.

## 1. Gratis Warranty Term and Gratis Warranty Range

If any faults or defects (hereinafter "Failure") found to be the responsibility of Mitsubishi occurs during use of the product within the gratis warranty term, the product shall be repaired at no cost via the sales representative or Mitsubishi Service Company. However, if repairs are required onsite at domestic or overseas location, expenses to send an engineer will be solely at the customer's discretion. Mitsubishi shall not be held responsible for any re-commissioning, maintenance, or testing on-site that involves replacement of the failed module.

### [Gratis Warranty Term]

For terms of warranty, please contact your original place of purchase.

### [Gratis Warranty Range]

- (1) The range shall be limited to normal use within the usage state, usage methods and usage environment, etc., which follow the conditions and precautions, etc., given in the instruction manual, user's manual and caution labels on the product.
- (2) Even within the gratis warranty term, repairs shall be charged for in the following cases.
  1. Failure occurring from inappropriate storage or handling, carelessness or negligence by the user. Failure caused by the user's hardware or software design.
  2. Failure caused by unapproved modifications, etc., to the product by the user.
  3. When the Mitsubishi product is assembled into a user's device, Failure that could have been avoided if functions or structures, judged as necessary in the legal safety measures the user's device is subject to or as necessary by industry standards, had been provided.
  4. Failure that could have been avoided if consumable parts (battery, backlight, fuse, etc.) designated in the instruction manual had been correctly serviced or replaced.
  5. Relay failure or output contact failure caused by usage beyond the specified life of contact (cycles).
  6. Failure caused by external irresistible forces such as fires or abnormal voltages, and failure caused by force majeure such as earthquakes, lightning, wind and water damage.
  7. Failure caused by reasons unpredictable by scientific technology standards at time of shipment from Mitsubishi.
  8. Any other failure found not to be the responsibility of Mitsubishi or that admitted not to be so by the user.

## 2. Onerous repair term after discontinuation of production

- (1) Mitsubishi shall accept onerous product repairs for seven (7) years after production of the product is discontinued.  
Discontinuation of production shall be notified with Mitsubishi Technical Bulletins, etc.
- (2) Product supply (including repair parts) is not available after production is discontinued.

## 3. Overseas service

Overseas, repairs shall be accepted by Mitsubishi's local overseas FA Center. Note that the repair conditions at each FA Center may differ.

## 4. Exclusion of loss in opportunity and secondary loss from warranty liability

Regardless of the gratis warranty term, Mitsubishi shall not be liable for compensation to:

- (1) Damages caused by any cause found not to be the responsibility of Mitsubishi.
- (2) Loss in opportunity, lost profits incurred to the user by Failures of Mitsubishi products.
- (3) Special damages and secondary damages whether foreseeable or not, compensation for accidents, and compensation for damages to products other than Mitsubishi products.
- (4) Replacement by the user, maintenance of on-site equipment, start-up test run and other tasks.

## 5. Changes in product specifications

The specifications given in the catalogs, manuals or technical documents are subject to change without prior notice.

## 6. Product application

- (1) In using the Mitsubishi MELSEC programmable controller, the usage conditions shall be that the application will not lead to a major accident even if any problem or fault should occur in the programmable controller device, and that backup and fail-safe functions are systematically provided outside of the device for any problem or fault.
- (2) The Mitsubishi programmable controller has been designed and manufactured for applications in general industries, etc. Thus, applications in which the public could be affected such as in nuclear power plants and other power plants operated by respective power companies, and applications in which a special quality assurance system is required, such as for railway companies or public service purposes shall be excluded from the programmable controller applications.  
In addition, applications in which human life or property that could be greatly affected, such as in aircraft, medical applications, incineration and fuel devices, manned transportation, equipment for recreation and amusement, and safety devices, shall also be excluded from the programmable controller range of applications. However, in certain cases, some applications may be possible, providing the user consults their local Mitsubishi representative outlining the special requirements of the project, and providing that all parties concerned agree to the special circumstances, solely at the user's discretion.
- (3) Mitsubishi shall have no responsibility or liability for any problems involving programmable controller trouble and system trouble caused by DoS attacks, unauthorized access, computer viruses, and other cyberattacks.

# INFORMATION AND SERVICES

---

For further information and services, please contact your local Mitsubishi Electric sales office or representative.  
Visit our website to find our locations worldwide.

MITSUBISHI ELECTRIC Factory Automation Global Website

Locations Worldwide

[www.MitsubishiElectric.com/fa/about-us/overseas/](http://www.MitsubishiElectric.com/fa/about-us/overseas/)

# TRADEMARKS

---

CANopen<sup>®</sup> is registered Community Trademarks of CAN in Automation e.V.

Microsoft and Windows are trademarks of the Microsoft group of companies.

The company names, system names and product names mentioned in this manual are either registered trademarks or trademarks of their respective companies.

In some cases, trademark symbols such as <sup>™</sup> or <sup>®</sup> are not specified in this manual.



TRANSLATION OF THE ORIGINAL INSTRUCTIONS

IB(NA)-0300251ENG-M(2602)MEE

MODEL: FX5SSC-U-S-E

MODEL CODE: 1XB018

## **MITSUBISHI ELECTRIC CORPORATION**

HEAD OFFICE: TOKYO BLDG., 2-7-3, MARUNOUCHI, CHIYODA-KU, TOKYO 100-8310, JAPAN  
NAGOYA WORKS: 1-14, YADA-MINAMI 5-CHOME, HIGASHI-KU, NAGOYA 461-8670, JAPAN

When exported from Japan, this manual does not require application to the  
Ministry of Economy, Trade and Industry for service transaction permission.

Specifications subject to change without notice.