

Mitsubishi Programmable Controller

Digital-Analog Converter Module type AJ65VBTCU-68DAVN User's Manual

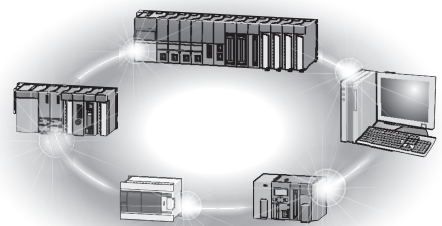

• SAFETY PRECAUTIONS •

(Read these precautions before using this product.)

Before using this product, please read this manual and the relevant manuals introduced in this manual carefully and pay full attention to safety to handle the product correctly.

The precautions given in this manual are concerned with this product. Refer to the user's manual of the CPU module to use for a description of the programmable controller system safety precautions.

In this manual, the safety precautions are classified into two levels: "⚠ WARNING" and "⚠ CAUTION".



Indicates that incorrect handling may cause hazardous conditions, resulting in death or severe injury.



Indicates that incorrect handling may cause hazardous conditions, resulting in minor or moderate injury or property damage.

Under some circumstances, failure to observe the precautions given under "⚠ CAUTION" may lead to serious consequences.

Observe the precautions of both levels because they are important for personal and system safety. Make sure that the end users read this manual and then keep the manual in a safe place for future reference.

[Design Precautions]

⚠ WARNING

- Install a safety circuit external to the programmable controller that keeps the entire system safe even when there are problems with the external power supply or the programmable controller. Otherwise, trouble could result from erroneous output or erroneous operation.
 - (1) The status of analog output changes depending on the setting of various functions that control the analog output. Take sufficient caution when setting for those functions. For details of analog output status, refer to Section 3.4.1 "Combinations of various functions"
 - (2) Normal output may not be obtained due to malfunctions of output elements or the internal circuits. So build an external monitoring circuit that will monitor any single outputs that could cause serious trouble.

⚠ CAUTION

- Do not bunch the control wires or communication cables with the main circuit or power wires, or install them close to each other. They should be installed 100mm (3.94inch) or more from each other. Not doing so could result in noise that would cause erroneous operation.
- At power ON/OFF, voltage or current may instantaneously be output from the output terminal of this module. In such case, wait until the analog output becomes stable to start controlling the external device.

[Installation Precautions]

CAUTION

- Use the programmable controller in an environment that meets the general specifications in the detailed manual.
Failure to do so may result in electric shock, fire, malfunction, or damage to or deterioration of the product.
- Securely fix the module with a DIN rail or CC-Link connector type metal installation fitting.
Not doing so can cause a drop or malfunction.
- Do not directly touch any conductive part of the module.
Doing so can cause malfunction or failure of the module.

[Wiring Precautions]

CAUTION

- Shut off the external power supply for the system in all phases before wiring.
Failure to do so may result in damage to the product.
- Individually ground the FG terminal of the programmable controller with a ground resistance of 100Ω or less.
Failure to do so may result in malfunction.
- Check the rated voltage and pin layout before wiring to the module, and connect the cables correctly.
Connecting a power supply with a different voltage rating or incorrect wiring may cause a fire or failure.
- Do not insert the one-touch connector plug for I/O of the one-touch connector type/connector type compact remote I/O unit into the one-touch connector for analog I/O accidentally.
Doing so can cause the module to be damaged.
- Prevent foreign matter such as dust or wire chips from entering the module.
Such foreign matter can cause a fire, failure, or malfunction.
- Attach an unwired connector plug to an unused one-touch connector for power supply and FG.
Not doing so can cause a failure or malfunction.
- Place the cables in a duct or clamp them.
If not, dangling cable may swing or inadvertently be pulled, resulting in damage to the module or cables or malfunction due to poor contact.
- Do not install the control lines or communication cables together with the main circuit lines or power cables.
Failure to do so may result in malfunction due to noise.
- When disconnecting the cable from the module, do not pull the cable by the cable part.
Loosen the screws of connector before disconnecting the cable.
Failure to do so may result in damage to the module or cable or malfunction due to poor contact.
- Smoke and fire may occur when an overcurrent flows intermittently for a long period of time. To avoid this, configure a safety circuit, such as an external fuse, to protect the product.

[Starting and Maintenance Precautions]

CAUTION

- Do not touch any pin while power is on. Doing so will cause malfunction.
- Shut off the external power supply for the system in all phases before cleaning the module.
Failure to do so may cause the module to fail or malfunction.
- Do not disassemble or modify the modules.
Doing so may cause failure, malfunction, injury, or a fire.
- Do not drop or apply strong shock to the module. Doing so may damage the module.
- Shut off the external power supply for the system in all phases before mounting or removing the module to or from the panel.
Failure to do so may cause the module to fail or malfunction.
- After the first use of the product, do not mount/remove the terminal block to/from the module more than 50 times. (IEC 61131-2 compliant)
- Before handling the module, touch a grounded metal object to discharge the static electricity from the human body.
Failure to do so may cause the module to fail or malfunction.

[Disposal Precautions]

CAUTION

- When disposing of this product, treat it as industrial waste.

• CONDITIONS OF USE FOR THE PRODUCT •

- (1) Mitsubishi programmable controller ("the PRODUCT") shall be used in conditions;
 - i) where any problem, fault or failure occurring in the PRODUCT, if any, shall not lead to any major or serious accident; and
 - ii) where the backup and fail-safe function are systematically or automatically provided outside of the PRODUCT for the case of any problem, fault or failure occurring in the PRODUCT.

- (2) The PRODUCT has been designed and manufactured for the purpose of being used in general industries.

MITSUBISHI SHALL HAVE NO RESPONSIBILITY OR LIABILITY (INCLUDING, BUT NOT LIMITED TO ANY AND ALL RESPONSIBILITY OR LIABILITY BASED ON CONTRACT, WARRANTY, TORT, PRODUCT LIABILITY) FOR ANY INJURY OR DEATH TO PERSONS OR LOSS OR DAMAGE TO PROPERTY CAUSED BY the PRODUCT THAT ARE OPERATED OR USED IN APPLICATION NOT INTENDED OR EXCLUDED BY INSTRUCTIONS, PRECAUTIONS, OR WARNING CONTAINED IN MITSUBISHI'S USER, INSTRUCTION AND/OR SAFETY MANUALS, TECHNICAL BULLETINS AND GUIDELINES FOR the PRODUCT.

("Prohibited Application")

Prohibited Applications include, but not limited to, the use of the PRODUCT in;

- Nuclear Power Plants and any other power plants operated by Power companies, and/or any other cases in which the public could be affected if any problem or fault occurs in the PRODUCT.
- Railway companies or Public service purposes, and/or any other cases in which establishment of a special quality assurance system is required by the Purchaser or End User.
- Aircraft or Aerospace, Medical applications, Train equipment, transport equipment such as Elevator and Escalator, Incineration and Fuel devices, Vehicles, Manned transportation, Equipment for Recreation and Amusement, and Safety devices, handling of Nuclear or Hazardous Materials or Chemicals, Mining and Drilling, and/or other applications where there is a significant risk of injury to the public or property.

Notwithstanding the above, restrictions Mitsubishi may in its sole discretion, authorize use of the PRODUCT in one or more of the Prohibited Applications, provided that the usage of the PRODUCT is limited only for the specific applications agreed to by Mitsubishi and provided further that no special quality assurance or fail-safe, redundant or other safety features which exceed the general specifications of the PRODUCTS are required. For details, please contact the Mitsubishi representative in your region.

REVISIONS

* The manual number is given on the bottom left of the back cover.

| Print Date | * Manual Number | Revision |
|------------|-------------------|--|
| Apr., 2003 | SH (NA)-080402E-A | First Printing |
| Sep., 2004 | SH (NA)-080402E-B | <p>Addition</p> <p>Section 4.8.3, 4.10.1 to 4.10.3</p> <p>Correction</p> <p>SAFETY PRECAUTIONS, About Manuals, Section 1.2, 2.4, 3.2, 3.6.6, 4.8.2</p> |
| Jul., 2005 | SH (NA)-080402E-C | <p>Correction</p> <p>SAFETY PRECAUTIONS</p> |
| Dec., 2006 | SH (NA)-080402E-D | <p>Correction</p> <p>Section 4.3, Appendix 2</p> |
| Dec., 2010 | SH (NA)-080402E-E | <p>Addition</p> <p>CONDITIONS OF USE THE PRODUCT, 4.10.1</p> <p>Correction</p> <p>SAFETY PRECAUTIONS, Related Manuals, About the Generic Terms and Abbreviations, Section 1, Chapter 1.2, 2.2, 2.4, 3.1 to 3.4, 3.4.1, 3.5.2, 3.6.1, 3.6.2, 3.6.4, 4.2, 4.4, 4.8.2, 4.9.1, 4.9.2, 4.10.3, 4.10.4, 4.11, 5.2.1, 5.2.2, 5.2.5, 5.3.1, 5.4.1, 6.1, 6.2</p> <p>Renumbering</p> <p>Section 4.10.1 to 4.10.3 → 4.10.2 to 4.10.4</p> |
| Jun., 2012 | SH (NA)-080402E-F | <p>Correction</p> <p>ABOUT MANUALS, COMPLIANCE WITH EMC AND LOW VOLTAGE DIRECTIVES, Section 2.4, 3.1, 3.2, 4.8.1, 4.8.2, 5.2.2, 5.2.5</p> |
| | | |

Japanese Manual Version SH-080397-F

This manual confers no industrial property rights or any rights of any other kind, nor does it confer any patent licenses. Mitsubishi Electric Corporation cannot be held responsible for any problems involving industrial property rights which may occur as a result of using the contents noted in this manual.

© 2003 MITSUBISHI ELECTRIC CORPORATION

INTRODUCTION

Thank you for purchasing the MELSEC-A series programmable controllers.
Before using this product, please read this manual carefully and develop familiarity with the functions and performance of the MELSEC-A series programmable controller to handle the product correctly.
Make sure that the end users read this manual.

CONTENTS

| | |
|--|----------------------|
| SAFETY PRECAUTIONS..... | A- 1 |
| CONITIONS OF USE THE PRODUCT..... | A- 4 |
| REVISIONS..... | A- 5 |
| INTRODUCTION..... | A- 6 |
| ABOUT MANUALS..... | A- 8 |
| COMPLIANCE WITH EMC AND LOW VOLTAGE DIRECTIVES..... | A- 8 |
| ABOUT THE GENERIC TERMS AND ABBREVIATIONS..... | A- 9 |
| PRODUCT COMPONENTS..... | A-10 |
| 1. OVERVIEW | 1- 1 to 1- 3 |
| 1.1 CC-Link Compatible Functions..... | 1- 1 |
| 1.2 Features..... | 1- 2 |
| 2. SYSTEM CONFIGURATION | 2- 1 to 2- 6 |
| 2.1 Overall Configuration..... | 2- 1 |
| 2.2 Applicable System..... | 2- 3 |
| 2.3 Precautions for System Configuration..... | 2- 4 |
| 2.4 Parts Sold Separately..... | 2- 5 |
| 3. SPECIFICATION | 3- 1 to 3- 19 |
| 3.1 General Specification..... | 3- 1 |
| 3.2 Performance Specification..... | 3- 2 |
| 3.3 I/O Conversion Characteristics..... | 3- 3 |
| 3.3.1 Voltage output characteristics..... | 3- 4 |
| 3.3.2 Relationship between offset/gain setting and analog output value..... | 3- 5 |
| 3.3.3 Accuracy..... | 3- 5 |
| 3.3.4 Conversion speed..... | 3- 6 |
| 3.4 Function..... | 3- 7 |
| 3.4.1 Combinations of various functions..... | 3- 8 |
| 3.5 Remote I/O Signals..... | 3- 9 |
| 3.5.1 Remote I/O signal list..... | 3- 9 |
| 3.5.2 Functions of the remote I/O signals..... | 3-12 |
| 3.6 Remote Register..... | 3-14 |
| 3.6.1 Allocation of the remote register..... | 3-14 |
| 3.6.2 CH. <input type="checkbox"/> digital value setting (Addresses RWwm+0H to RWwm+7H)..... | 3-16 |
| 3.6.3 Analog output enable/disable setting (Address RWwm+8H)..... | 3-16 |
| 3.6.4 CH. <input type="checkbox"/> output range setting (Address RWwm+9H, RWwm+AH)..... | 3-17 |
| 3.6.5 HOLD/CLEAR setting (Address RWwm+BH)..... | 3-17 |
| 3.6.6 CH. <input type="checkbox"/> check code (Addresses RWrn+0H to RWrn+7H)..... | 3-18 |
| 3.6.7 Error code (Address RWm+8H)..... | 3-18 |

| | |
|--|-----------------------------|
| 4. SETUP AND PREPARATION BEFORE OPERATION | 4- 1 to 4- 25 |
| 4.1 Pre-Operation Procedure..... | 4- 1 |
| 4.2 Precautions When Handling | 4- 1 |
| 4.3 Name of Each Part..... | 4- 3 |
| 4.4 Concept of Mode Select Switch Setting (Selection of Remote Device Station Compatible Version)... | 4- 6 |
| 4.5 Offset/Gain Setting..... | 4- 8 |
| 4.6 Section Number Setting..... | 4-10 |
| 4.7 Facing Direction of the Module Installation | 4-10 |
| 4.8 Data Link Cable Wiring | 4-11 |
| 4.8.1 Connection of the CC-Link dedicated cables | 4-12 |
| 4.8.2 How to connect connectors | 4-13 |
| 4.9 Wiring..... | 4-14 |
| 4.9.1 Wiring precautions..... | 4-14 |
| 4.9.2 Wiring of module with external equipment | 4-15 |
| 4.10 How to Wire the One-Touch Connector Plug | 4-16 |
| 4.10.1 Precautions for the transition wiring of the one-touch connector for power supply and FG..... | 4-16 |
| 4.10.2 Wiring procedures for the one-touch connector | 4-18 |
| 4.10.3 Wiring procedures for the one-touch connector for communication | 4-21 |
| 4.10.4 Wiring procedures for the one-touch connector for power supply and FG | 4-23 |
| 4.11 Maintenance and Inspection..... | 4-25 |
| 5. PROGRAMMING | 5- 1 to 5- 33 |
| 5.1 Programming Procedure..... | 5- 1 |
| 5.2 When Remote Net Ver. 1 Mode Is Used..... | 5- 2 |
| 5.2.1 Conditions of Program Example | 5- 2 |
| 5.2.2 Program Example for Use of the QCPU (Q mode)..... | 5- 4 |
| 5.2.3 Program Example for Use of the QnACPU | 5-10 |
| 5.2.4 Program Example for Use of the ACP/QCPU (A mode) (dedicated instructions)..... | 5-12 |
| 5.2.5 Program Example for Use of the ACP/QCPU (A mode) (FROM/TO instructions) | 5-15 |
| 5.3 When Remote Net Ver. 2 Mode Is Used..... | 5-17 |
| 5.3.1 Conditions of program examples | 5-17 |
| 5.3.2 Setting of parameters and initialization procedure registration..... | 5-20 |
| 5.3.3 Program example | 5-23 |
| 5.4 When Remote Net Additional Mode Is Used | 5-25 |
| 5.4.1 Conditions of program examples | 5-25 |
| 5.4.2 Setting of parameters and initialization procedure registration..... | 5-28 |
| 5.4.3 Program example | 5-31 |
| 6. TROUBLESHOOTING | 6- 1 to 6- 5 |
| 6.1 Error Code List | 6- 1 |
| 6.2 Using the LED Indications to Check Errors..... | 6- 2 |
| 6.3 Troubleshooting for the Case where the "ERR." LED of the Master Station Flickers | 6- 4 |
| APPENDICES | APPX - 1 to APPX - 3 |
| Appendix 1 Comparison, Differences and Compatibility between New and Conventional Models | APPX- 1 |
| Appendix 2 External dimension diagram..... | APPX - 3 |
| INDEX | INDEX- 1 to INDEX- 2 |

ABOUT MANUALS

The following manuals are also related to this product.

Order each manual as needed, referring to the following list.

Relevant manuals

| Manual name | Manual number (model code) |
|--|-------------------------------|
| CC-Link System Master/Local Module Type AJ61BT11/A1SJ61BT11 User's Manual System configuration, performance specifications, functions, handling, wiring, and troubleshooting of the AJ61BT11 and A1SJ61BT11 (Sold separately) | IB-66721 (13J872) |
| CC-Link System Master/Local Module Type AJ61QBT11/A1SJ61QBT11 User's Manual System configuration, performance specifications, functions, handling, wiring, and troubleshooting of the AJ61QBT11 and A1SJ61QBT11 (Sold separately) | IB-66722 (13J873) |
| MELSEC-Q CC-Link System Master/Local Module User's Manual System configuration, performance specifications, functions, handling, wiring, and troubleshooting of the QJ61BT11N (Sold separately) | SH-080394E (13JR64) |
| Type AnSHCPU/AnACPU/AnUCPU/QCPU-A (A Mode) Programming Manual (Dedicated Instructions) Explains the instructions extended for the AnSHCPU/AnACPU/AnUCPU/QCPU-A (A Mode). (Sold separately) | IB-66251 (13J742) |
| MELSEC-L CC-Link System Master/Local Module User's Manual Settings, specifications, handling, data communication methods, and troubleshooting of the built-in CC-Link function of the CPU module or the CC-Link system master/local module (Sold separately) | SH-080895ENG (13JZ41) |

COMPLIANCE WITH EMC AND LOW VOLTAGE DIRECTIVES

(1) Method of ensuring compliance

To ensure that Mitsubishi programmable controllers maintain EMC and Low Voltage Directives when incorporated into other machinery or equipment, certain measures may be necessary. Please refer to one of the following manuals.

- User's manual for the CPU module or head module used
- Safety Guidelines

(This manual is included with the CPU module, base unit, or head module.)

The CE mark on the side of the programmable controller indicates compliance with EMC, Low Voltage, and Machinery Directives.

(2) Additional measures

To ensure that this product maintains EMC and Low Voltage Directives, please refer to one of the manuals listed under (1).

ABOUT THE GENERIC TERMS AND ABBREVIATIONS

Unless otherwise specified, the following generic terms and abbreviations are used in this manual to describe Type AJ65VBTCU-68DAVN analog-digital converter module.

| Generic Term/Abbreviation | Description |
|----------------------------|---|
| GX Developer | Product name of the software package for the MELSEC programmable Controllers. |
| GX Works2 | |
| ACPU | Generic term for A0J2HCPU, A1SCPU, A1SCPUC24-R2, A1SHCPU, A1SJCPU, A1SJCPU-S3, A1SJHCPU, A1NCP, A2NCP, A2NCP-S1, A3NCP, A2SCPU, A2SHCPU, A2ACPU, A2ACPU-S1, A3ACPU, A2UCPU, A2UCPU-S1, A2USCPU, A2USCHPU-S1, A2USHCPU-S1, A3UCPU and A4UCPU |
| QnACPU | Generic term for Q2ACPU, Q2ACPU-S1, Q2ASCPU, Q2ASCPU-S1, Q2ASHCPU, Q2ASHCPU-S1, Q3ACPU, Q4ACPU and Q4ARCPU |
| QCPU (A mode) | Generic term for Q02CPU-A, Q02HCPU-A and Q06HCPU-A |
| QCPU (Q mode) | Generic term for Q00JCPU, Q00CPU, Q01CPU, Q02CPU, Q02HCPU, Q06HCPU, Q12HCPU, Q25HCPU, Q02PHCPU, Q06PHCPU, Q12PHCPU, Q25PHCPU, Q12PRHCPU, Q25PRHCPU, Q00UJCPU, Q00UCPU, Q01UCPU, Q02UCPU, Q03UDCPU, Q04UDHCPU, Q06UDHCPU, Q10UDHCPU, Q13UDHCPU, Q20UDHCPU, Q26UDHCPU, Q03UDECPU, Q04UDEHCPU, Q06UDEHCPU, Q10UDEHCPU, Q13UDEHCPU, Q20UDEHCPU, Q26UDEHCPU, Q50UDEHCPU and Q100UDEHCPU. |
| LCPU | Generic term for L02CPU, L26CPU-BT |
| Master station | Station that controls the data link system. One master station is required for each system. |
| Local station | Station having a programmable controller CPU and the ability to communicate with the master and other local stations. |
| Remote I/O station | Remote station that handles bit unit data only. (Performs input and output with external devices.) (AJ65BTB1-16D, AJ65SBTB1-16D) |
| Remote device station | Remote station that handles bit unit and word unit data only. (Performs input and output with external devices, and analog data exchange.) |
| Remote station | Generic term for remote I/O station and remote device station. (Controlled by the master station) |
| Intelligent device station | Station that can perform transient transmission, such as the AJ65BT-R2N (including local stations). |
| Master module | Generic term for modules that can be used as the master station. |
| SB | Link special relay (for CC-Link) Bit unit information that indicates the module operating status and data link status of the master station/local station. (Expressed as SB for convenience) |
| SW | Link special register (for CC-Link) 16 bit unit information that indicates the module operating status and data link status of the master station/local station. (Expressed as SW for convenience) |
| RX | Remote input (for CC-Link) Information entered in bit units from the remote station to the master station. (Expressed as RX for convenience) |
| RY | Remote output (for CC-Link) Information output in bit units from the master station to the remote station. (Expressed as RY for convenience) |
| RWw | Remote register (Write area for CC-Link) Information output in 16-bit units from the master station to the remote device station. (Expressed as RWw for convenience) |
| RWr | Remote register (Read area for CC-Link) Information entered in 16-bit units from the remote device station to the master station. (Expressed as RWr for convenience) |

PRODUCT COMPONENTS

This product consists of the following.

| Product Name | Quantity |
|--|----------|
| Type AJ65VBTCU-68DAVN digital-analog converter module | 1 |
| Type AJ65VBTCU-68DAVN digital-analog converter module user's manual (hardware) | 1 |

1 OVERVIEW

1

This user's manual explains the specifications, handling, programming methods and others of Type AJ65VBTCU-68DAVN digital-analog converter module (hereafter abbreviated to the "AJ65VBTCU-68DAVN") which is used as a remote device station of a CC-Link system.

The AJ65VBTCU-68DAVN is a module designed to convert digital values (16-bit signed BIN data) from outside the programmable controller into analog values (voltages or currents).

This module is a voltage output-dedicated model.

For the explanation of this product, the conventional AJ65VBTCU-68DAV digital-analog converter module (hereafter abbreviated to the "AJ65VBTCU-68DAV") is also described in some parts of this manual.

1.1 CC-Link Compatible Functions

This product supports the following CC-Link functions.

- Cyclic transmission
- Expanded cyclic transmission
- Interstation cable length lessening

1.2 Features

This section gives the features of the AJ65VBTCU-68DAVN.

(1) High accuracy

This module performs D/A conversion at the accuracy of $\pm 0.3\%$ relative to the maximum value of the analog output value at the operating ambient temperature of 0 to 55°C, or at $\pm 0.2\%$ relative to the maximum value of the analog output value at the operating ambient temperature of $25\pm 5^\circ\text{C}$.

(2) Output range selectable per channel

You can choose the analog output range per channel to change the I/O conversion characteristics.

(3) High resolution of $1/\pm 4000$

By changing the output range, you can choose and set the resolution to either $1/4000$ or $1/\pm 4000$ (when the -10 to +10V range or user range setting 1 is selected) to provide high-resolution analog values.

(4) Setting of analog output hold or clear at STOP of programmable controller CPU

You can specify whether to hold or clear the analog value which is being output from each channel of the unit when the programmable controller CPU has entered the STOP mode or the AJ65VBTCU-68DAV has stopped D/A conversion due to error occurrence.

(5) Sharply reducible wiring man-hours

Wiring man-hours can be reduced sharply by adopting individual wire insulation displacement termination type one-touch connectors (no need for soldering, shield peeling and screwing) to connect the communication and power supply cables.

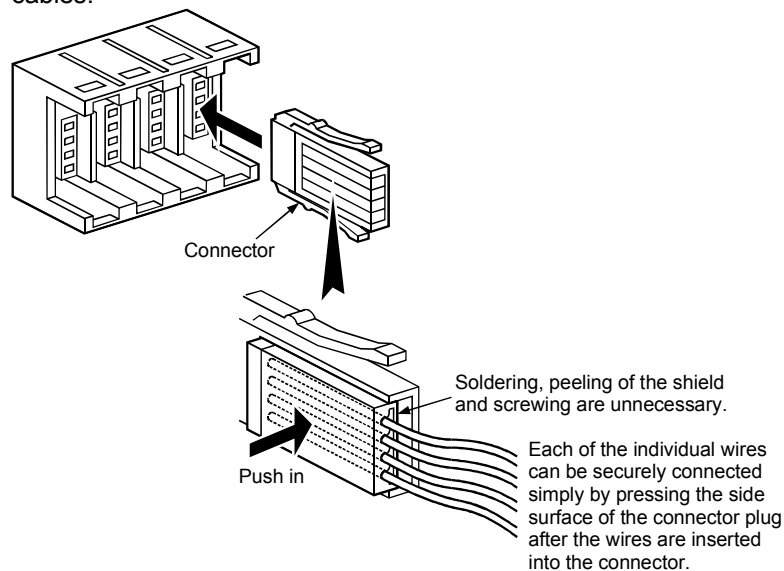

(6) Significant improvement of wiring performance

The above one-touch connectors for IN and OUT sides are plugged individually, greatly improving the performance of jumper wiring especially in an enclosure. (Mixed jumper wiring of the power supply cables with the I/O modules is not allowed.)

(7) Replacement of module without stopping CC-Link system

The use of the online connectors (for communication, for power supply) allows the module to be changed without the CC-Link system being stopped.

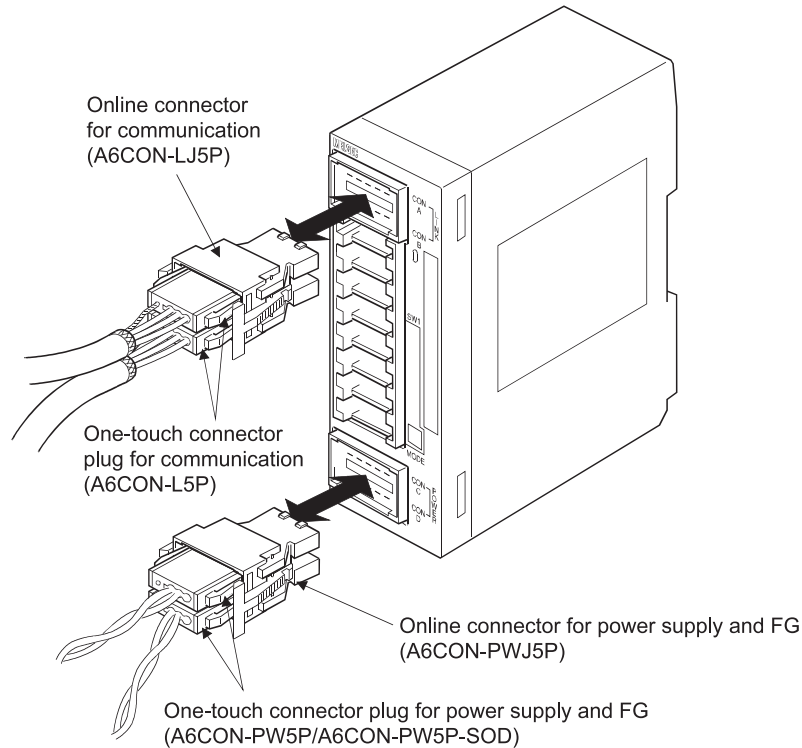

(8) Improved wiring workability

The connectors and setting switches are all front-mounted. This enables connections to be made only by front wiring, improving wiring workability. It also allows setting to be made after installation to an enclosure.

(9) Compatibility with conventional modules

Complete compatibility with the conventional AJ65VBTCU-68DAV module has been achieved in the ver. 1 remote device station setting. (Refer to Section 4.4.)

(10) Selection of optimum mode for system

The optimum mode can be selected according to the system. (Refer to Section 4.4.)

| Mode | Outline |
|----------------------------|--|
| Remote net ver. 2 mode | Select this mode when configuring a new system. The number of connected remote device stations can be increased to up to 42 in combination with the applicable master module. |
| Remote net additional mode | This module can be newly added to the existing system in combination with the applicable master module. |
| Remote net ver. 1 mode | Complete compatibility mode of the conventional remote net mode. Select this mode when system expansion is not necessary or when this module replaces the conventional one as a maintenance product. |

2 SYSTEM CONFIGURATION

This chapter describes the system configuration for use of the AJ65VBTCU-68DAVN.

2.1 Overall Configuration

The overall configuration for use of the AJ65VBTCU-68DAVN is shown below.

(1) Remote net ver. 1 mode

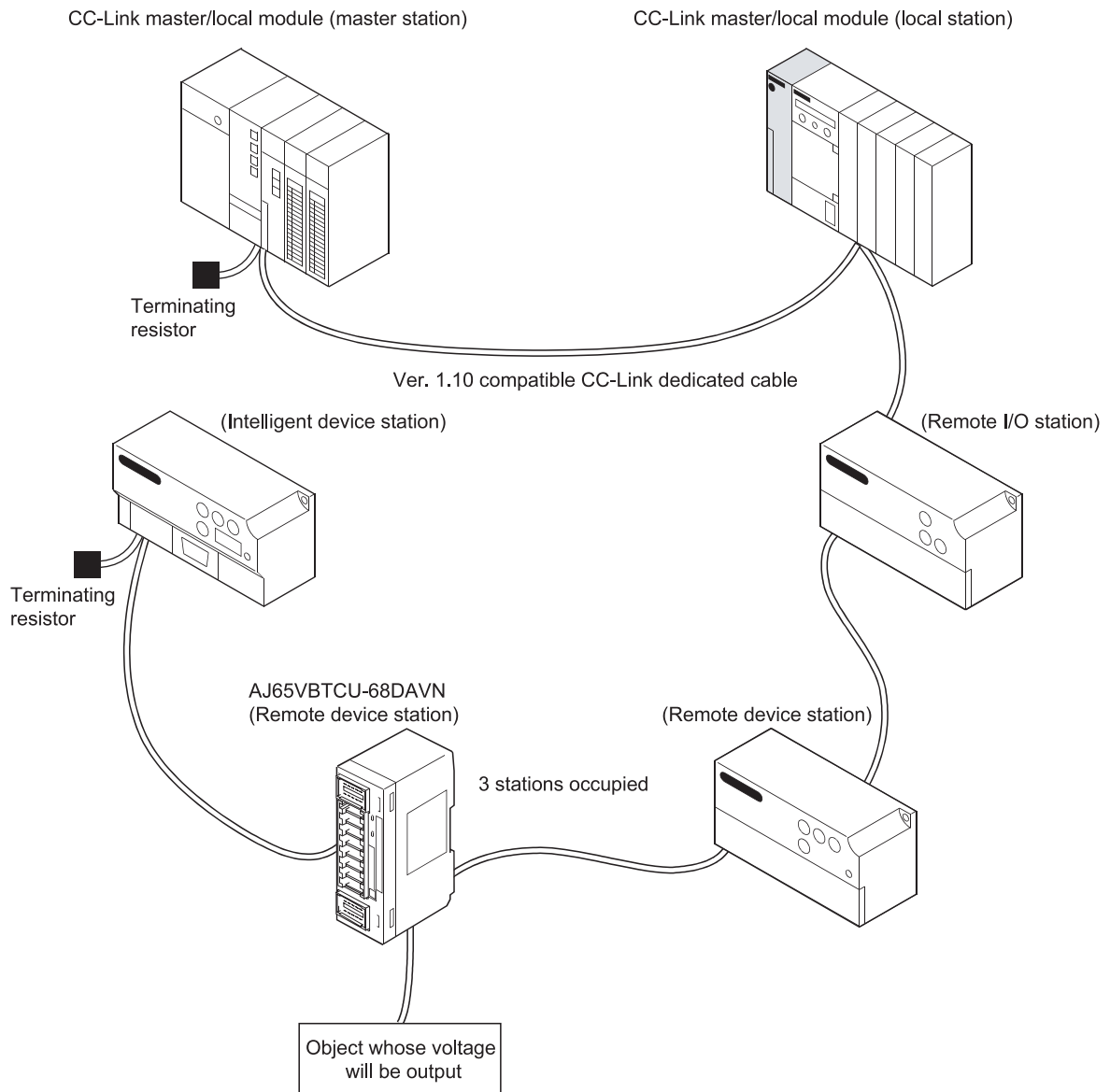

(2) Remote net ver. 2 mode, remote net additional mode

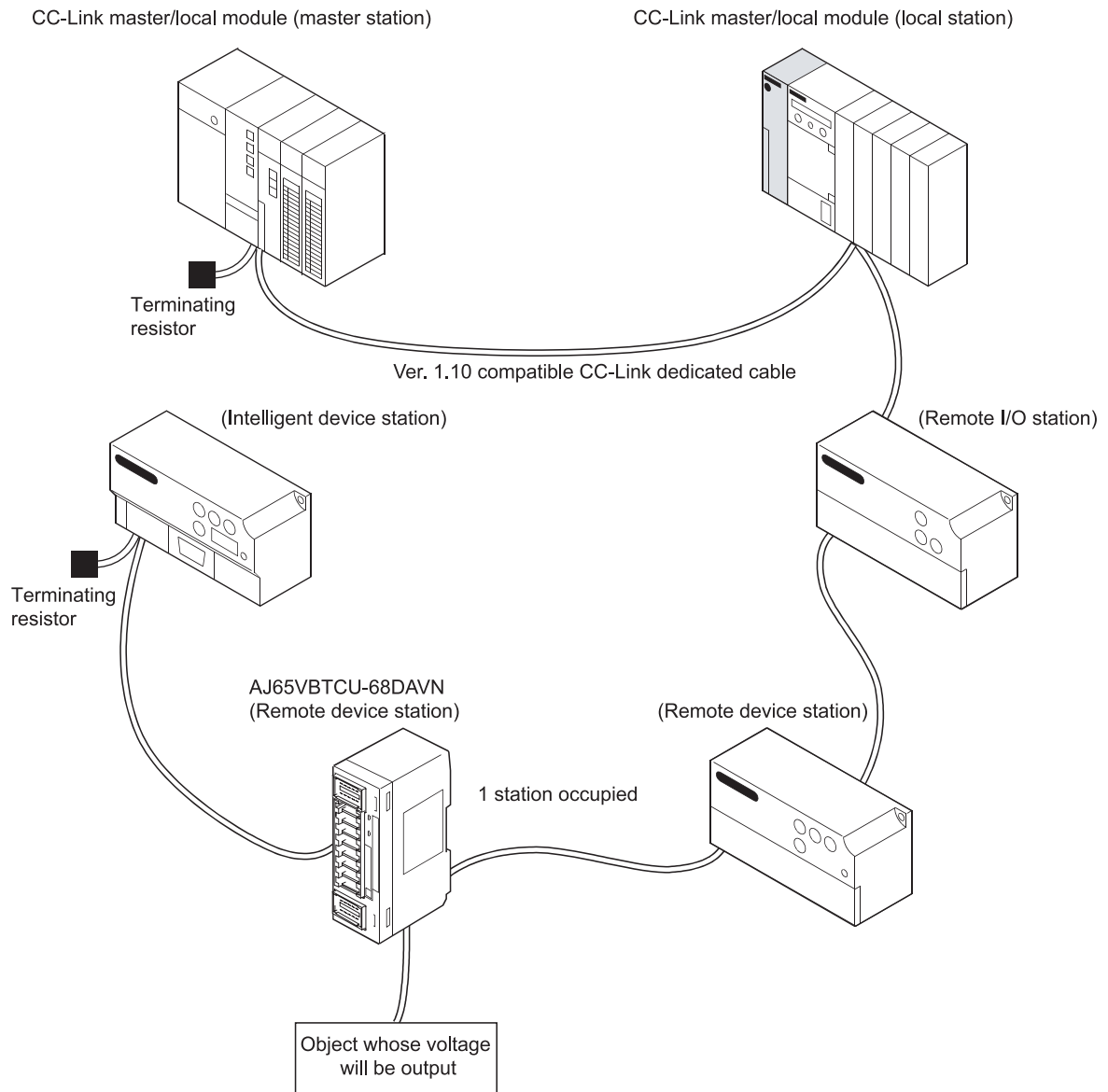

2.2 Applicable System

This section explains the applicable system.

(1) Applicable master modules

For available master modules, visit the CC-Link Partner Association (CLPA) website at:
<http://www.cc-link.org/>

REMARK

Check the specifications of the master module before use.

(2) Applicable combinations

The following table indicates usability according to the combinations of the master modules, the mode setting and station information (station type) of the GX Developer network parameters, and the mode select switch setting of the module.

○: Usable, ×: Unusable

| Master Module | GX Developer Network Parameter Setting | | Model Select Switch Setting * ¹ of AJ65VBTCU-68DAN | |
|--|--|------------------------------------|--|--|
| | Mode setting | Station information (station type) | Ver. 1 remote device station (Ver. 1 compatible slave station) | Ver. 2 remote device station (Ver. 2 compatible slave station) |
| QJ61BT11 AJ61BT11 A1SJ61BT11 AJ61QBT11 A1SJ61QBT11 | Remote net ver. 1 mode | Remote device station | ○ | × |
| | Remote net ver. 2 mode | Ver. 1 remote device station | × | × |
| | | Ver. 2 remote device station | | |
| | Remote net additional mode | Ver. 1 remote device station | × | × |
| Ver. 2 remote device station | | | | |
| QJ61BT11N L26CPU-BT LJ61BT11 | Remote net ver. 1 mode | Remote device station | ○ | × |
| | Remote net ver. 2 mode | Ver. 1 remote device station | ○ | × |
| | | Ver. 2 remote device station | × | ○ |
| | Remote net additional mode | Ver. 1 remote device station | ○ * ² | × |
| Ver. 2 remote device station | | × | ○ * ³ | |

*1 For details, refer to Section 4.3 and Section 4.4.

*2 When there is a station number used as the ver. 2 remote device station in the existing system, set the station number of the ver. 1 remote device station to be added before that station.

*3 Set the station number of the ver. 2 remote device station to be added after the station numbers used in the existing system.

| POINT |
|---|
| <p>For use in the remote net ver. 2 mode or remote net additional mode, the master module of QJ61BT11N and the peripheral software package of GX Developer Version 8.03D or later are required.</p> <p>For more information on the applicable modules (CPU modules, network modules) and applicable software packages, refer to the CC-Link System Master/Local Module User's Manual (Details) QJ61BT11N.</p> |

(3) Restrictions on use of CC-Link dedicated instructions (RLPA, RRPA)

The CC-Link dedicated instructions may not be used depending on the programmable controller CPU and master module used.

For details of the restrictions, refer to the A series master module user's manual, and the Programming Manual type AnSHCPU/AnACPU/AnUCPU/QCPU-A (A mode) (Dedicated Instructions).

This module does not allow the use of the dedicated instructions other than RLPA and RRPA.

Refer to Section 5.5 for a program example using the dedicated instructions (RLPA, RRPA).

2.3 Precautions for System Configuration

Before powering off or changing this module, stop the control of the mating equipment.

2.4 Parts Sold Separately

The plugs for AJ65VBTCU-68DAVN are sold separately.
Please purchase them as necessary.

| | Mitsubishi model name | Part model name (manufacturer) | Specifications | | | Color of the cover |
|--|-----------------------|--------------------------------|---|---------------------------------|-----------------------|--------------------|
| | | | Applicable cable core size | Applicable cable outer diameter | Maximum rated current | |
| Plug for one-touch connector * 1, * 4 | A6CON-P214 | 33104-6000FL * 5 | 0.14 to 0.2 mm ² (26 to 24 AWG) | φ 1.0 to 1.4 mm | 2 A * 7 | Transparent |
| | A6CON-P220 | 33104-6100FL * 5 | | φ 1.4 to 2.0 mm | | Yellow |
| | A6CON-P514 | 33104-6200FL * 5 | 0.3 to 0.5 mm ² (22 to 20 AWG) | φ 1.0 to 1.4 mm | 3 A * 7 | Red |
| | A6CON-P520 | 33104-6300FL * 5 | | φ 1.4 to 2.0 mm | | Blue |
| One-touch connector plug for communication * 2, * 4 | A6CON-L5P | 35505-6000-BOM GF * 5 | communication line 0.5 mm ² (20 AWG) | φ 2.2 to 3.0 mm | | Red |
| | | | shielded cable (drain wire) 0.5 mm ² (20 AWG) | | | |
| One-touch connector for power supply and FG * 2, * 4, * 6 | A6CON-PW5P | 35505-6080-A00 GF * 5 | 0.75 mm ² (0.66 to 0.98 mm ²) (18 AWG) wire diameter 0.16 mm or more Outer insulation layer material PVC (Heat-resistant vinyl) | φ 2.2 to 3.0 mm | 7 A * 7 | Gray |
| | A6CON-PW5P-SOD | 35505-6180-A00 GF * 5 | | φ 2.0 to 2.3 mm | | Blue |
| Online connector for communication * 3 | A6CON-LJ5P | 35720-L200-B00 AK * 5 | — | — | — | — |
| Online connector for power supply and FG * 3 | A6CON-PWJ5P | 35720-L200-A00 AK * 5 | — | — | — | — |
| One-touch connector plug with terminating resistor (1 piece) | A6CON-TR11 | — | With terminating resistor (110 Ω) | | — | — |
| | A6CON-TR11N | | With terminating resistor (110 Ω) (built-in type) | | | |

- *1 Mitsubishi's A6CON-P□□□ includes 20 plugs.
- *2 Mitsubishi's A6CON-□5P includes 10 plugs.
- *3 Mitsubishi's A6CON-□J5P includes 5 plugs.
- *4 Once insulation-displaced, the one-touch connector plugs cannot be reused.
- *5 Sumitomo 3M Co., Ltd.
- *6 Confirm the outer sheath diameter of the applicable cable and select the connector.
- *7 Keep the current within the allowable range of the connected cable.

REMARK

The following table indicates the connectors of this module with which the above plugs/connectors are compatible.

| Connector of This Module | Compatible Optional Parts |
|---|--|
| One-touch connector for communication | <ul style="list-style-type: none">• One-touch connector plug for communication• Online connector for communication• One-touch connector plug with terminating resistor |
| One-touch connector for power supply and FG | <ul style="list-style-type: none">• One-touch connector plug for power supply and FG• Online connector for power supply and FG |
| One-touch connector for analog I/O | <ul style="list-style-type: none">• Plug for one-touch connector |

3 SPECIFICATION

This chapter provides the specifications of the AJ65VBTCU-68DAVN.

3.1 General Specification

Table 3.1 indicates the general specifications of the AJ65VBTCU-68DAVN.

Table 3.1 General specification

| Item | Specification | | | | | |
|-----------------------------|---|--------------------------------|----------------------------------|----------------------------|----------------------------|---------------------|
| Usage ambient temperature | 0 to 55°C | | | | | |
| Storage ambient temperature | -20 to 75°C | | | | | |
| Usage ambient humidity | 10 to 90%RH, no condensation | | | | | |
| Storage ambient humidity | | | | | | |
| Vibration durability | Conforming to JIS B 3502, IEC 61131-2 | | Frequency | Constant acceleration | Half amplitude | Number of sweeps |
| | | | For intermittent vibration | 5 to 8.4Hz 8.4 to 150Hz | — 9.8m/s ² | |
| | | For continuous vibration | 5 to 8.4Hz 8.4 to 150Hz | — 4.9m/s ² | 1.75mm (0.069inch) — | — |
| | | | | | | |
| Shock durability | Conforming to JIS B 3502, IEC61131-2 (147m/s ² , 3 times each in 3 directions) | | | | | |
| Usage environment | No corrosive gas | | | | | |
| Usage height *3 | 0 to 2000m | | | | | |
| Installation area | Within the control board | | | | | |
| Over-voltage category *1 | II or less | | | | | |
| Pollution level *2 | Less than 2 | | | | | |

*1 This indicates the section of the power supply to which the equipment is assumed to be connected between the public electrical power distribution network and the machinery within premises.
Category II applies to equipment for which electrical power is supplied from fixed facilities.
The surge voltage withstand level for up to the rated voltage of 300V is 2500V.

*2 This index indicates the degree to which conductive material is generated in terms of the environment in which the equipment is used.
Pollution level 2 is when only non-conductive pollution occurs. A temporary conductivity caused by condensing must be expected occasionally.

*3 Do not use or store the programmable controller under pressure higher than the atmospheric pressure of altitude 0m. Doing so may cause malfunction. When using the programmable controller under pressure, please consult your local Mitsubishi representative.

3.2 Performance Specification

Table 3.2 indicates the performance specifications of the AJ65VBTCU-68DAVN.

Table 3.2 Performance Specifications

| Item | AJ65VBTCU-68DAVN | | | | |
|--|--|---|-------------------------------|---|-----------------|
| Protection class | IP1XB | | | | |
| Digital input | 16-bit signed binary (-4096 to 4095) | | | | |
| Analog output | -10 to 10VDC (external load resistance: 2kΩ to 1MΩ) | | | | |
| I/O characteristics, maximum resolution, accuracy *1 (accuracy relative to maximum value of analog output value) | Digital Input Value | Analog Output Range | Accuracy | | Max. Resolution |
| | | | Ambient temperature 0 to 55°C | Ambient temperature 25±5°C | |
| | -4000 to 4000 | -10 to 10V | ±0.3% (±30mV) | ±0.2% (±20mV) | 2.5mV |
| | | User range setting 1 (-10 to 10V) | | | |
| 0 to 4000 | 0 to 5V | ±0.3% (±15mV) | ±0.2% (±10mV) | 1.25mV | |
| | 1 to 5V | | | 1.0mV | |
| | | User range setting 2 (0 to 5V) | | | |
| Maximum conversion speed | 1ms/channel | | | | |
| Output short-circuit protection | Provided | | | | |
| Absolute maximum output | ±12V | | | | |
| Number of analog output points | 8 channels/module | | | | |
| CC-Link station type | Remote device station (Ver.1 remote device station, Ver.2 remote device station) | | | | |
| Number of occupied stations | When a Ver.2 remote device station (Ver.2-compatible slave station) is set: 1 station (RX/RX: 32 points for each, RWr/RWw: 16 points for each, expanded cyclic setting: Quadruple) | | | | |
| Communication cable | Ver. 1.10 compatible CC-Link dedicated cable FANC-110SBH, FA-CBL200PSBH, CS-110 | | | | |
| Insulation | Insulated area | Insulation method | Dielectric withstand voltage | Insulation resistance | |
| | Across communication system terminals and all analog output terminals | Photocoupler | 500V AC for 1 minute | 5MΩ or higher, measured with 500V DC insulation resistance tester | |
| | Across power supply system terminals and all analog output terminals | Transformer | | | |
| | Between channels | Non-insulation | - | - | |
| Noise durability | By noise simulator of 500Vp-p noise voltage, 1μs noise width and 25 to 60Hz noise frequency | | | | |
| External wiring system | One-touch connector for communication [Transmission circuit] (5 pins pressure welding type, the plug for the connector is sold separately) One-touch connector for power supply and FG [Unit power supply and FG] (5 pins pressure welding type, the plug for the connector is sold separately) One-touch connector for analog I/O (4 pins pressure welding type, the plug for the connector is sold separately) <Sold separately> Online connector for communication : A6CON-LJ5P Online connector for power supply : A6CON-PWJ5P | | | | |
| Applicable wire size | One-touch connector for communication | Communication line : Ver. 1.10 compatible CC-Link dedicated cable 0.5mm ² (20AWG) [φ2.2 to 3.0], shielded wire 0.5mm ² (20AWG) | | | |
| | One-touch connector for power supply and FG | 0.66 to 0.98 mm ² (18AWG) [φ2.2 to 3.0] Wire diameter 0.16 mm or more | | | |
| | One-touch connector for analog I/O | φ1.0 to 1.4 (A6CON-P214), φ1.4 to 2.0 (A6CON-P220) [Applicable cable : 0.14 to 0.2 mm ²] φ1.0 to 1.4 (A6CON-P514), φ1.4 to 2.0 (A6CON-P520) [Applicable cable : 0.3 to 0.5 mm ²] | | | |
| Applicable DIN rail | TH35-7.5Fe, TH35-7.5Al (conforming to JIS C 2812) | | | | |
| | CC-Link connector type metal installation fitting : A6PLT-J65V1 | | | | |

| | |
|-----------------------|--|
| Item | AJ65VBTCU-68DAVN |
| External supply power | 24V DC (20.4V DC to 26.4V DC, ripple factor within 5%) |
| | Inrush current : 4.3A, within 1.2ms |
| | Current consumption 0.15A (When 24VDC) |
| Weight | 0.16kg |

*1 For the details of the I/O conversion characteristic, refer to Section 3.3.

3.3 I/O Conversion Characteristics

An I/O conversion characteristic indicates an inclination of a straight line which connects an offset value and a gain value at the time when a digital value set from the programmable controller CPU is converted into an analog value (voltage or current output).

The offset value is an analog value (voltage) output when the digital value set from the programmable controller CPU is 0.

The gain value is an analog value (voltage) output when the digital value set from the programmable controller CPU is 4000.

3.3.1 Voltage output characteristics

The voltage output characteristic graph is shown below.

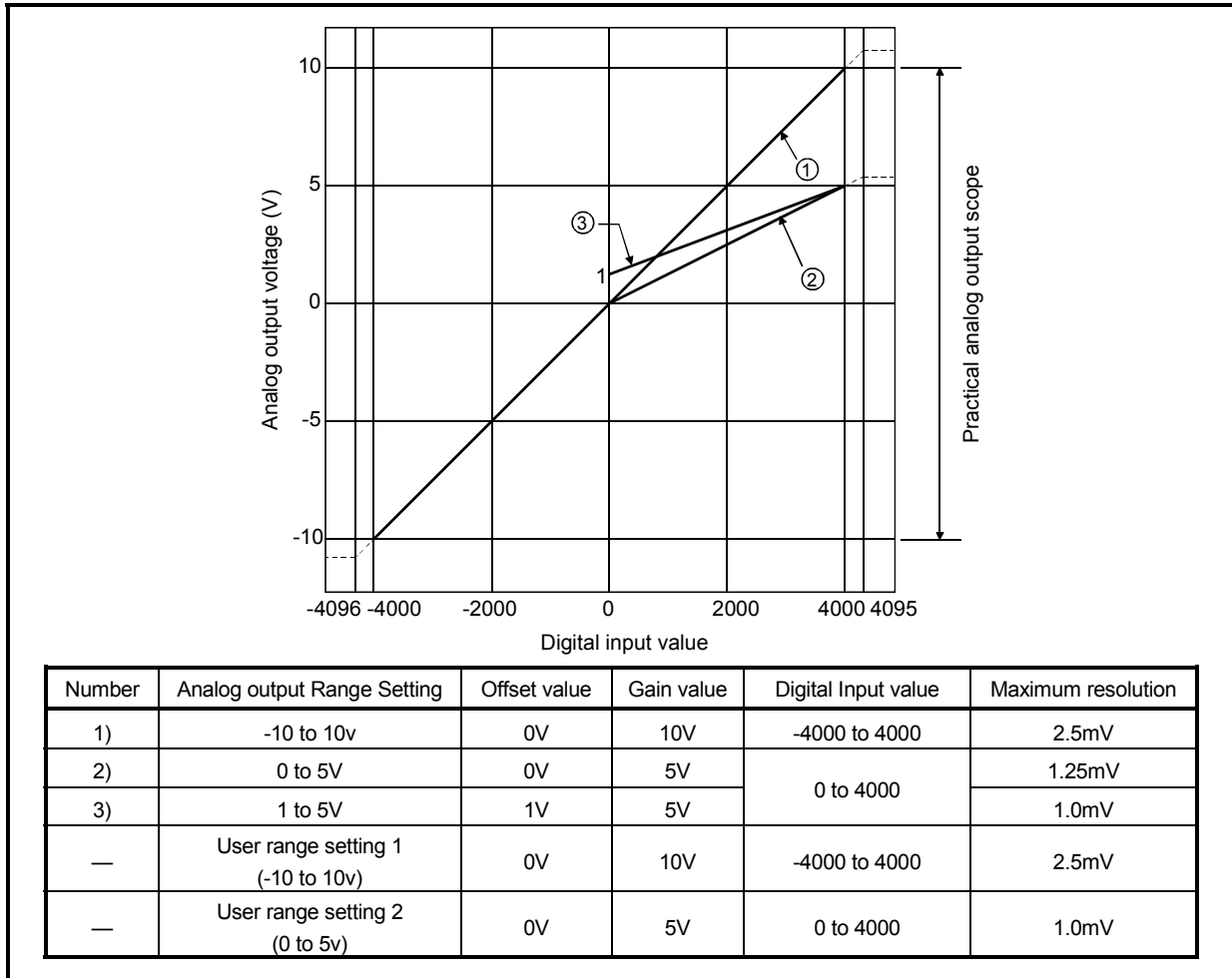

Fig. 3.1 Voltage Output Characteristic

| POINT |
|--|
| <p>(1) Within the digital input and analog output scopes of each output range, the maximum resolution and accuracy are within the performance specification range. Outside those scopes, however, they may not fall within the performance specification range. (Avoid using the dotted line part in Fig. 3.1.)</p> <p>(2) Set the offset and gain values of the user range setting within the range satisfying the following conditions.</p> <p>(a) Setting range when user range setting 1 is selected: -10 to 10V</p> <p>(b) Setting range when user range setting 2 is selected: 0 to 5V</p> <p>(c) (Gain value) > (Offset value)</p> <p>If you attempt to make setting outside the setting range of (a) or (b), the "RUN" LED flickers at 0.5s intervals. Set the values within the setting range.</p> <p>If you attempt to make setting outside the setting range of (c), the "RUN" LED flickers at 0.5s intervals. Make setting again.</p> |

3.3.2 Relationship between offset/gain setting and analog output value

How to calculate the analog output value:

The resolution of AJ65VBTCU-68DAVN can be set arbitrarily by modifying the setting of the offset value and gain value.

How to calculate the analog value resolution and the analog output value for a given digital input value when the settings of the offset value and gain value are changed is shown next.

(1) Resolution

Find the resolution with the following expression.

$$(\text{Analog resolution}) = \frac{(\text{Gain value}) - (\text{Offset value})}{4000}$$

(2) Analog output value

Find the analog output value with the following expression.

$$(\text{Analog output}) = (\text{Analog resolution}) \times (\text{Digital input value}) + (\text{Offset value})$$

3.3.3 Accuracy

Accuracy is relative to the maximum value of the analog output value.

If you change the offset/gain setting or output range to change the output characteristic, accuracy does not change and is held within the range indicated in the performance specifications.

(1) Accuracy of voltage output

For voltage output, the maximum value of the analog output value changes with the range.

For example, accuracy is relative to 5V when the 0 to 5V range is selected.

Analog output is provided at the accuracy of within $\pm 0.2\%$ ($\pm 10\text{mV}$) when the operating ambient temperature is $25\pm 5^\circ\text{C}$, or within $\pm 0.3\%$ ($\pm 15\text{mV}$) when the operating ambient temperature is 0 to 55°C .

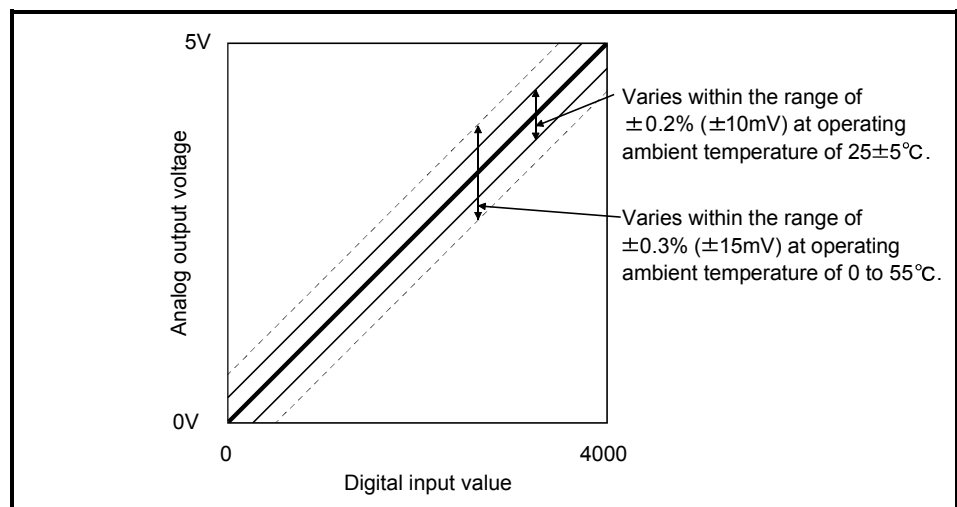

Fig. 3.2 Voltage Output Accuracy (When 0 to 5V Range Is Selected)

3.3.4 Conversion speed

Conversion speed indicates time required to read the digital output value written to the buffer memory, perform D/A conversion, and then output the specified analog value.

Conversion speed per channel of the AJ65VBTCU-68DAVN is 1ms.

Due to the data link processing time of the CC-Link system, there is a transmission delay until the D/A conversion value is read actually.

For the data link processing time, refer to the user's manual of the master module used.

Example1) Ver. 1 remote device station (ver. 1 compatible slave station) setting
Data link processing time taken in the asynchronous mode when the
master module is the QJ61BT11 (normal value)

[Calculation expression]

$SM + LS \times 1 + \text{remote device station processing time}$

SM: Scan time of master station sequence program

LS : Link scan time

Remote device station processing time: (Number of channels used + 1 *)

× 1ms

*: Internal processing time of AJ65VBTCU-68DAVN

Example 2) Ver. 2 remote device station (ver. 2 compatible slave station) setting
Data link processing time taken in the asynchronous mode when the
master module is the QJ61BT11N (normal value)

[Calculation expression]

(a) In the case of the remote input (RX), remote register (RW_r)

$SM + LS \times 1 \times m + \text{remote device station processing time}$

(b) In the case of the remote output (RY), remote register (RW_w)

$SM + LS \times 1 \times (m + 1) + \text{remote device station processing time}$

SM: Scan time of master station sequence program

LS : Link scan time

M : Constant *1

Remote device station processing time: (Number of channels used + 1 *2)

× 1ms

*1: Expanded cyclic setting is quadruple in this module, m = 7.

*2: Internal processing time of AJ65VBTCU-68DAVN

3.4 Function

Table 3.3 lists the functions of the AJ65VBTCU-68DAVN.

Table 3.3 AJ65VBTCU-68DAVN Function List

| Item | Description | Refer to | | | | | | | | | | | | |
|--|---|---------------|-----------|------------|----|---------|----|---------|----|-----------------------------------|----|--------------------------------|----|---------------|
| D/A output enable/disable function | Specify whether the D/A conversion value is output or the offset value is output per channel. Note that the conversion speed is constant independently of the output enable/disable setting. | Section 3.5.2 | | | | | | | | | | | | |
| D/A conversion enable/disable function | Specify whether D/A conversion is enabled or disabled per channel. The sampling cycle can be shortened by setting the unused channel to D/A conversion disable. | Section 3.6.3 | | | | | | | | | | | | |
| Output range changing function | <p>You can set the analog output range per channel to change the I/O conversion characteristics.</p> <p>Select the output range setting from among the following 5 types.</p> <table border="1" data-bbox="453 824 1198 1032"> <thead> <tr> <th data-bbox="453 824 826 855">Output Range</th> <th data-bbox="826 824 1198 855">Set Value</th> </tr> </thead> <tbody> <tr> <td data-bbox="453 855 826 887">-10 to 10V</td> <td data-bbox="826 855 1198 887">0H</td> </tr> <tr> <td data-bbox="453 887 826 918">0 to 5V</td> <td data-bbox="826 887 1198 918">1H</td> </tr> <tr> <td data-bbox="453 918 826 949">1 to 5V</td> <td data-bbox="826 918 1198 949">2H</td> </tr> <tr> <td data-bbox="453 949 826 981">User range setting 1 (-10 to 10V)</td> <td data-bbox="826 949 1198 981">3H</td> </tr> <tr> <td data-bbox="453 981 826 1012">User range setting 2 (0 to 5V)</td> <td data-bbox="826 981 1198 1012">4H</td> </tr> </tbody> </table> | Output Range | Set Value | -10 to 10V | 0H | 0 to 5V | 1H | 1 to 5V | 2H | User range setting 1 (-10 to 10V) | 3H | User range setting 2 (0 to 5V) | 4H | Section 3.6.4 |
| Output Range | Set Value | | | | | | | | | | | | | |
| -10 to 10V | 0H | | | | | | | | | | | | | |
| 0 to 5V | 1H | | | | | | | | | | | | | |
| 1 to 5V | 2H | | | | | | | | | | | | | |
| User range setting 1 (-10 to 10V) | 3H | | | | | | | | | | | | | |
| User range setting 2 (0 to 5V) | 4H | | | | | | | | | | | | | |
| Function to specify hold or clear of the analog output when the programmable controller CPU is in the STOP status (HOLD/CLEAR setting) | Specify per channel whether to hold or clear (output the offset value) the analog value which is being output from each channel when the programmable controller CPU has entered the STOP status or the AJ65VBTCU-68DAVN has stopped D/A conversion due to error occurrence. | Section 3.6.5 | | | | | | | | | | | | |
| Offset/gain setting | You can make offset/gain setting per channel without potentiometers to change the I/O conversion characteristics freely. | Section 4.4 | | | | | | | | | | | | |

3.4.1 Combinations of various functions

You can set the analog output as indicated in Table 3.4 by combining the Analog output enable/disable setting (RWwm+8), CH. analog output enable/disable flag (RYn0 to RYn7) and HOLD/CLEAR setting (RWwm+B).

Make setting according to your system application.

Table 3.4 Analog output status combination list

| Setting combination Execution status | Analog output enable/disable setting (RWwm+8) | Enable | | | Prohibit |
|---|---|---|--------------|----------------|-------------------|
| | CH. <input type="checkbox"/> analog output enable/disable flag (RYn0 to RYn7) | Enable (ON) | | Prohibit (OFF) | Enable or disable |
| | HOLD/CLEAR setting (RWwm+B) | HOLD | CLEAR | HOLD or CLEAR | HOLD or CLEAR |
| Analog output status when the programmable controller CPU is in the RUN status | | Output of the analog value after D/A conversion from the digital value specified by the programmable controller CPU | | Offset value | 0V |
| Analog output status when the programmable controller CPU is in the STOP status | | Analog value before the programmable controller CPU stop is retained | Offset value | Offset value | 0V |
| Analog output status at programmable controller CPU stop error | | Analog value before the programmable controller CPU stop is retained | Offset value | Offset value | 0V |
| Analog output status at occurrence of AJ65VBTCU-68DAV digital value setting error | | Output of the maximum or minimum analog value | | Offset value | 0V |
| Analog output status when the "L RUN" LED turns off/"L.ERR" LED turns on | | The analog value before the "L RUN" LED turns off is retained. | Offset value | Offset value | 0V |
| Analog output status when the "L ERR." LED flickers | | Output of the analog value after D/A conversion from the digital value specified by the programmable controller CPU | | Offset value | 0V |
| Analog output status in initial processing completion status after power-reset | | Output of the analog value after D/A conversion from the digital value specified by the programmable controller CPU | | Offset value | 0V |
| Analog output status at occurrence of AJ65VBTCU-68DAVN output range setting error | | 0V | 0V | 0V | 0V |
| Analog output status at occurrence of AJ65VBTCU-68DAVN watchdog timer error | | 0V | 0V | 0V | 0V |

POINT

When the QnACPU is used, using "Y" as the remote output (RY) refresh device of the automatic refresh parameter may not hold the analog value even for the HOLD setting.

For the HOLD setting, use "M" or "B" as the remote output (RY) refresh device.

3.5 Remote I/O Signals

This section describes the assignment and functions of the remote I/O signals.

3.5.1 Remote I/O signal list

Remote inputs (RX) mean the input signals from the AJ65VBTCU-68DAVN to the master module, and remote outputs (RY) mean the output signals from the master module to the AJ65VBTCU-68DAVN.

In communications with the master station, the AJ65VBTCU-68DAVN uses 32 points of the remote inputs (RX) and 32 points of the remote outputs (RY).

The number of stations occupied by this module differs between ver. 1 remote device station (ver. 1 compatible slave station) setting and ver. 2 remote device station (ver. 2 compatible slave station) setting.

3 stations are occupied in the case of ver. 1 remote device station (ver. 1 compatible slave station) setting. The latter 64 points are not used.

1 station is occupied in the case of ver. 2 remote device station (ver. 2 compatible slave station) setting. Expanded cyclic setting is fixed to quadruple and the latter 32 points are not used.

(1) Remote I/O signal list for ver. 1 remote device station (ver. 1 compatible slave station) setting

Table 3.5 indicates the assignment and names of the remote I/O signals for ver. 1 remote device station (ver. 1 compatible slave station) setting.

Table 3.5 Remote I/O Signal List for Ver. 1 Remote Device Station
(Ver. 1 Compatible Slave Station) Setting

| Signal Direction: AJ65VBTCU-68DAVN → Master Module | | Signal Direction: Master Module → AJ65VBTCU-68DAVN | |
|--|--------------------------------------|--|--|
| Remote input (RX) | Name | Remote output (RY) | Name |
| RXn0 to RXnB | Reserved | RYn0 | CH.1 analog output enable/disable flag |
| | | RYn1 | CH.2 analog output enable/disable flag |
| | | RYn2 | CH.3 analog output enable/disable flag |
| | | RYn3 | CH.4 analog output enable/disable flag |
| | | RYn4 | CH.5 analog output enable/disable flag |
| | | RYn5 | CH.6 analog output enable/disable flag |
| | | RYn6 | CH.7 analog output enable/disable flag |
| | | RYn7 | CH.8 analog output enable/disable flag |
| RXnC | E ² PROM write error flag | RYn8 to RY (n+1) 7 | Reserved |
| RXnD to RX (n+1) 7 | Reserved | | |
| RX (n+1) 8 | Initial data processing request flag | RY (n+1) 8 | Initial data processing complete flag |
| RX (n+1) 9 | Initial data setting complete flag | RY (n+1) 9 | Initial data setting request flag |
| RX (n+1) A | Error status flag | RY (n+1) A | Error reset request flag |
| RX (n+1) B | Remote READY | RY (n+1) B to RY (n+5) F | Reserved |
| RX (n+1) C to RX (n+5) F | Reserved | | |

POINT

The reserved devices given in Table 3.5 are used by the system and cannot be used by the user.

If the user has used (turned on/off) any of them, we cannot guarantee the functions of the AJ65VBTCU-68DAVN.

(2) Remote I/O signal list for ver. 2 remote device station (ver. 2 compatible slave station) setting

Table 3.6 indicates the assignment and names of the remote I/O signals for ver. 2 remote device station (ver. 2 compatible slave station) setting.

Table 3.6 Remote I/O Signal List for Ver. 2 Remote Device Station (Ver. 2 Compatible Slave Station) Setting

| Signal Direction: AJ65VBTCU-68DAVN → Master Module | | Signal Direction: Master Module → AJ65VBTCU-68DAVN | |
|--|--------------------------------------|--|--|
| Remote input (RX) | Name | Remote output (RY) | Name |
| RXn0 to RXnB | Reserved | RYn0 | CH.1 analog output enable/disable flag |
| | | RYn1 | CH.2 analog output enable/disable flag |
| | | RYn2 | CH.3 analog output enable/disable flag |
| | | RYn3 | CH.4 analog output enable/disable flag |
| | | RYn4 | CH.5 analog output enable/disable flag |
| | | RYn5 | CH.6 analog output enable/disable flag |
| | | RYn6 | CH.7 analog output enable/disable flag |
| | | RYn7 | CH.8 analog output enable/disable flag |
| RXnC | E ² PROM write error flag | RYn8 to RY (n+1) 7 | Reserved |
| RXnD to RX (n+1) 7 | Reserved | | |
| RX (n+1) 8 | Initial data processing request flag | RY (n+1) 8 | Initial data processing complete flag |
| RX (n+1) 9 | Initial data setting complete flag | RY (n+1) 9 | Initial data setting request flag |
| RX (n+1) A | Error status flag | RY (n+1) A | Error reset request flag |
| RX (n+1) B | Remote READY | RY (n+1) B to RY (n+3) F | Reserved |
| RX (n+1) C to RX (n+3) F | Reserved | | |

POINT

The reserved devices given in Table 3.6 are used by the system and cannot be used by the user.

If the user has used (turned on/off) any of them, we cannot guarantee the functions of the AJ65VBTCU-68DAVN.

3.5.2 Functions of the remote I/O signals

Table 3.6 explains the functions of the remote I/O signals of the AJ65VBTCU-68DAVN.

Table 3.7 Remote I/O Signal Details (1/2)

| Device No. | Signal Name | Description |
|------------|--------------------------------------|--|
| RXnC | E ² PROM write error flag | Turns on the number of E ² PROM write times exceeds its limit (1000,000 times per channel). If this flag has turned on, this module itself has failed (hardware fault) and therefore this flag cannot be reset (turned off) by the error reset request flag. At occurrence of this error, power on the AJ65VBTCU-68DAVN again. If this flag turns on after the power is switched on again, it is a hardware fault. Contact your nearest Mitsubishi representative. |
| RX (n+1) 8 | Initial data processing request flag | <p>After power-on, the initial data processing request flag is turned on by the AJ65VBTCU-68DAVN to request the initial data to be set.</p> <p>Also, after the initial data processing is complete (initial data processing complete flag RY (n+1) 8 ON), the flag is turned off.</p> <p> RX(n+1)8 Initial data processing request flag RY(n+1)8 Initial data processing completion flag RX(n+1)9 Initial data setting completion flag RY(n+1)9 Initial data setting request flag RX(n+1)B Remote ready </p> <p> ← : Performed by sequence program ← : Performed by AJ65VBTCU-68DAVN </p> |
| RX (n+1) 9 | Initial data setting complete flag | When the initial data setting request (RY (n+1) 9 ON) is made, the flag turns on after the initial data setting completion is done. Also, after the initial data setting is complete, the initial setting complete flag turns off when the initial data setting request flag turns off. |
| RX (n+1) A | Error status flag | <p>Turns on at occurrence of the output range setting error, digital value setting error or E²PROM write error (RXnC).</p> <p>Does not turn on at occurrence of the watchdog timer error. (The "RUN" LED goes off.)</p> <p> RX(n+1)A Error status flag RY(n+1)A Error reset request flag RWn+8 Error code RWn to RWn+7 CH. □ check code </p> <p> ← : Performed by sequence program ← : Performed by AJ65VBTCU-68DAVN </p> |
| RX (n+1) B | Remote READY | Turns on when initial data setting is completed after power-on or at termination of the test mode. (Used for interlocking read/write from/to the master module.) |

n: Address allocated to the master module by station number setting.

Table 3.7 Remote I/O Signal Details (2/2)

| Device No. | Signal Name | Description |
|--------------------|---|--|
| RYn0 to RYn7 | CH. <input type="checkbox"/> analog output enable/disable flag | D/A conversion value output enable flag for channel 1 to 8. Turn on this flag to enable the D/A conversion value of the corresponding channel to be output. Turn off when you want to disable the output of the D/A conversion value. Processed on the leading edge of ON/OFF. |
| RY (n+1) 8 | Initial data processing complete flag | Turns on after initial data processing completion when initial data processing is requested after power-on or test mode operation. |
| RY (n+1) 9 | Initial data setting request flag | Turns on at the time of initial data setting or changing. |
| RY (n+1) A | Error reset request flag | Turning on this flag resets (turns off) the error status flag (RX(n+1)A) and also clears (to 0000H) the error code (RWm+8) and CH. <input type="checkbox"/> check code (RWm to RWm+7) in the remote register. However, since the E ² PROM write error flag (RXnC) cannot be reset, the error status flag remains on, too. |

n: Address allocated to the master module by station number setting.

3.6 Remote Register

The AJ65VBTCU-68DAVN has a remote register for data communication with the master module. The remote register allocation and data structures are described below.

3.6.1 Allocation of the remote register

The number of data of the AJ65VBTCU-68DAVN differs between ver. 1 remote device station (ver. 1 compatible slave station) setting and ver. 2 remote device station (ver. 2 compatible slave station) setting.

(1) Remote register assignment for ver. 1 remote device station (ver. 1 compatible slave station) setting

Table 3.8 indicates the remote register assignment for ver. 1 remote device station (ver. 1 compatible slave station) setting.

Table 3.8 Remote Register Assignment for Ver. 1 Remote Device Station
(Ver. 1 Compatible Slave Station) Setting

| Transfer Direction | Address | Description | Default Value | Refer to |
|--------------------|---------|--------------------------------------|---------------|---------------|
| Master → Remote | RWwm+0H | CH. 1 digital value setting | 0 | Section 3.6.2 |
| | RWwm+1H | CH. 2 digital value setting | 0 | |
| | RWwm+2H | CH. 3 digital value setting | 0 | |
| | RWwm+3H | CH. 4 digital value setting | 0 | |
| | RWwm+4H | CH. 5 digital value setting | 0 | |
| | RWwm+5H | CH. 6 digital value setting | 0 | |
| | RWwm+6H | CH. 7 digital value setting | 0 | |
| | RWwm+7H | CH. 8 digital value setting | 0 | |
| | RWwm+8H | Analog output enable/disable setting | 0 | Section 3.6.3 |
| | RWwm+9H | CH. 1 to 4 output range setting | 0 | Section 3.6.4 |
| | RWwm+AH | CH. 5 to 8 output range setting | 0 | |
| | RWwm+BH | HOLD/CLEAR setting | 0 | Section 3.6.5 |
| Remote → Master | RWrn+0H | CH. 1 check code | 0 | Section 3.6.5 |
| | RWrn+1H | CH. 2 check code | 0 | |
| | RWrn+2H | CH. 3 check code | 0 | |
| | RWrn+3H | CH. 4 check code | 0 | |
| | RWrn+4H | CH. 5 check code | 0 | |
| | RWrn+5H | CH. 6 check code | 0 | |
| | RWrn+6H | CH. 7 check code | 0 | |
| | RWrn+7H | CH. 8 check code | 0 | |
| | RWrn+8H | Error code | 0 | Section 3.6.7 |
| | | RWrn+9H to RWrn+BH | Reserved | 0 |

m, n: The address set for the master station in the station number setting.

POINT

Do not execute read or write to the remote register that is not allowed to use. When a read or write is executed, the functions of the AJ65VBTCU-68DAVN is not guaranteed.

(2) Remote register assignment for ver. 2 remote device station (ver. 2 compatible slave station) setting

Table 3.9 indicates the remote register assignment for ver. 2 remote device station (ver. 2 compatible slave station) setting.

Table 3.9 Remote Register Assignment for Ver. 2 Remote Device Station (Ver. 2 Compatible Slave Station) Setting

| Transfer Direction | Address | Description | Default Value | Refer to |
|--------------------|---------|--------------------------------------|---------------|---------------|
| Master → Remote | RWwm+0H | CH. 1 digital value setting | 0 | Section 3.6.2 |
| | RWwm+1H | CH. 2 digital value setting | 0 | |
| | RWwm+2H | CH. 3 digital value setting | 0 | |
| | RWwm+3H | CH. 4 digital value setting | 0 | |
| | RWwm+4H | CH. 5 digital value setting | 0 | |
| | RWwm+5H | CH. 6 digital value setting | 0 | |
| | RWwm+6H | CH. 7 digital value setting | 0 | |
| | RWwm+7H | CH. 8 digital value setting | 0 | |
| | RWwm+8H | Analog output enable/disable setting | 0 | Section 3.6.3 |
| | RWwm+9H | CH. 1 to 4 output range setting | 0 | Section 3.6.4 |
| | RWwm+AH | CH. 5 to 8 output range setting | 0 | |
| | RWwm+BH | HOLD/CLEAR setting | 0 | Section 3.6.5 |
| | | RWwm+CH to RWwm+FH | Reserved | 0 |
| Remote → Master | RWrm+0H | CH. 1 check code | 0 | Section 3.6.5 |
| | RWrm+1H | CH. 2 check code | 0 | |
| | RWrm+2H | CH. 3 check code | 0 | |
| | RWrm+3H | CH. 4 check code | 0 | |
| | RWrm+4H | CH. 5 check code | 0 | |
| | RWrm+5H | CH. 6 check code | 0 | |
| | RWrm+6H | CH. 7 check code | 0 | |
| | RWrm+7H | CH. 8 check code | 0 | |
| | RWrm+8H | Error code | 0 | Section 3.6.7 |
| | | RWrm+9H to RWrm+FH | Reserved | 0 |

m, n: The address set for the master station in the station number setting.

| |
|--|
| POINT |
| Do not execute read or write to the remote register that is not allowed to use. When a read or write is executed, the functions of the AJ65VBTCU-68DAVN is not guaranteed. |

3.6.2 CH. □ digital value setting (Addresses RWwm+0H to RWwm+7H)

- (1) This area is used to write the digital value for the D/A conversion from the programmable controller CPU.
- (2) The digital value at all channels become “0” in the following conditions:
 - (a) After the power is turned on, when the remote READY (RX(n+1)B) is turned on.
- (3) The digital value that may be set is a 16-bit signed binary within the setting range which matches the output range setting.
 If a value beyond the range of the digital value resolution is set, the data in Table 3.8 is applied for the D/A conversion.
 In addition, the checking code is stored in the check code storage area (addresses RWm+0H to RWm+7H).

Table 3.8 Available setting range of the digital value

| Output Range | Available setting range | Digital value for the D/A conversion when the value beyond the range is set |
|--|---|---|
| -10 to 10V User range setting 1 | -4096 to 4095 (Practical scope: -4000 to 4000) | 4096 or more: 4095 -4097 or less: -4096 |
| 0 to 5V 1 to 5V User range setting 2 | -96 to 4095 (Practical scope: 0 to 4000) | 4096 or more: 4095 -97 or less: -96 |

3.6.3 Analog output enable/disable setting (Address RWwm+8H)

- (1) Set whether D/A conversion is enabled or disabled per channel.
- (2) Operation is performed according to the setting made for the leading edges of initial data setting request flag (RY(n+9)).
- (3) The default setting is conversion enable for all channels.

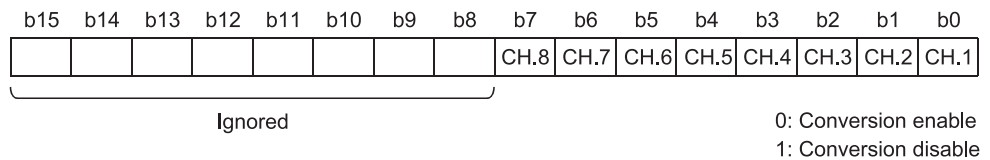

3.6.4 CH. \square output range setting (Address RWwm+9H, RWwm+AH)

- (1) Set the analog output range per channel.
- (2) Operation is performed according to the setting made for the leading edges of initial data setting request flag (RY(n+9)).
- (3) The default settings are -10 to 10V for all channels.

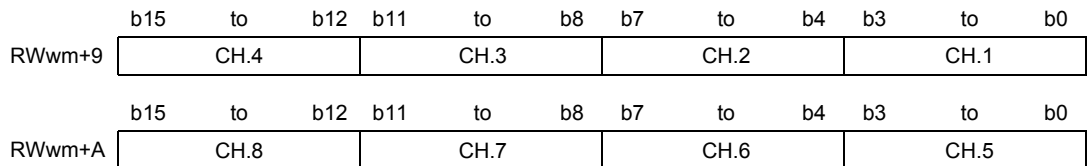

| Output range | Setting value |
|-----------------------------------|---------------|
| -10 to 10V | 0H |
| 0 to 5V | 1H |
| 1 to 5V | 2H |
| User range setting 1 (-10 to 10V) | 3H |
| User range setting 2 (0 to 5V) | 4H |

POINT

If the set value is outside the setting range, error "20 \square *" occurs, the "RUN" LED flickers at intervals of 0.1s, and all channels do not make D/A conversion.

* \square indicates the channel No. where the error occurred.

3.6.5 HOLD/CLEAR setting (Address RWwm+BH)

- (1) Set HOLD/CLEAR to each channel.
- (2) Operation is performed according to the setting made for the leading edges of initial data setting request flag (RY(n+9)).
- (3) The default settings are CLERA for all channels.

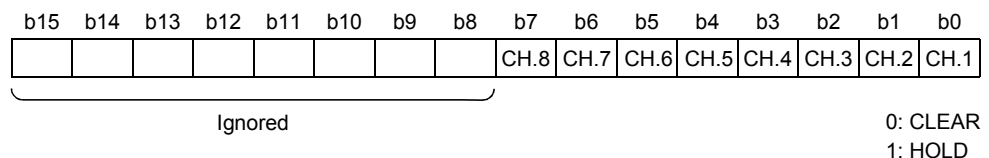

3.6.6 CH. check code (Addresses RWrn+0H to RWrn+7H)

- (1) This area is used to check if the digital value is within or out of the setting range. One of the following checking codes is stored when the digital value lower or higher than the setting range is set.

| Check code | Description |
|------------|--|
| 000FH | A digital value which exceeds the setting range was set. |
| 00F0H | A digital value which is below the setting range was set. |
| 00FFH | The digital value less than the setting range and the digital value more than the setting range were set before the error reset request. For example, the 00FFH check code is stored if a digital value exceeding the valid range is written, and then, without the check code being reset, a digital value that falls short of the valid range is written. |

- (2) The check code once stored is not reset even if the set value is set to within the valid setting allowed range.
- (3) The storage area or the check code is reset by turning on the error reset request flag (RY (n+1)A).

3.6.7 Error code (Address RWrn+8H)

If an error occurs (the RUN LED flickers) when data is written to the AJ65VBTCU-68DAVN, the corresponding error code is stored into the remote register (address RWrn+8H) of the AJ65VBTCU-68DAVN.

Refer to Section 6.1 for details of the error codes.

4 SETUP AND PREPARATION BEFORE OPERATION

4.1 Pre-Operation Procedure

This section explains the preparatory procedure for operating the AJ65VBTCU-68DAVN.

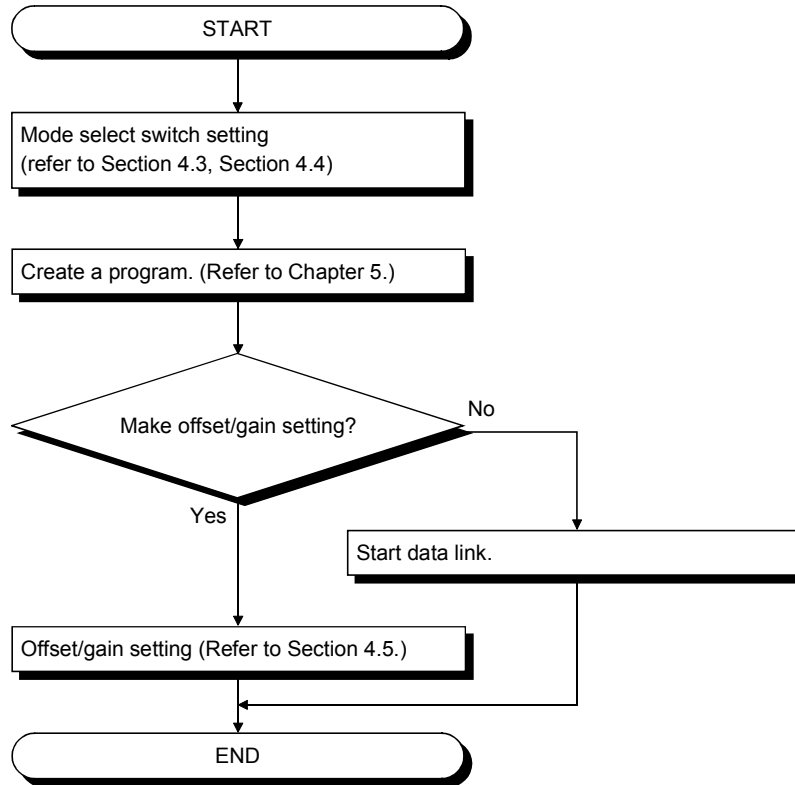

4.2 Precautions When Handling

The precautions when handling the AJ65VBTCU-68DAVN are described below:

CAUTION

- Do not touch any terminal while power is on. Doing so may cause malfunction.
- Prevent foreign matter such as dust or wire chips from entering the module. Such foreign matter can cause a fire, failure, or malfunction.
- Do not disassemble or modify the modules. Doing so may cause failure, malfunction, injury, or a fire.
- Do not directly touch any conductive part of the module. Doing so can cause malfunction or failure of the module.
- Do not drop or apply strong shock to the module. Doing so may damage the module.
- Tighten the terminal screw within the specified torque range. Undertightening can cause short circuit or malfunction. Overtightening can damage the screw and/or module, resulting in drop, short circuit, or malfunction.

 CAUTION

- When disposing of this product, treat it as industrial waste.
- Use the programmable controller in an environment that meets the general specifications in this manual.
Failure to do so may result in electric shock, fire, malfunction, or damage to or deterioration of the product.
- Securely fix the module with a DIN rail or mounting screws. Tighten the screws within the specified torque range.
Undertightening can cause drop of the screw, short circuit or malfunction.
Overtightening can damage the screw and/or module, resulting in drop, short circuit, or malfunction.
- Shut off the external power supply for the system in all phases before mounting or removing the module to or from the panel.
Failure to do so may cause the module to fail or malfunction.
- Before handling the module, touch a grounded metal object to discharge the static electricity from the human body.
Failure to do so may cause the module to fail or malfunction.

- (1) When using the DIN rail adapter, install the DIN rail by making sure of the following:
 - (a) Applicable DIN rail models (conforming to the JIS C 2812)
TH35-7.5Fe
TH35-7.5Al
 - (b) DIN rail installation screw interval
When installing the DIN rail, tighten the screws with less than 200mm (7.87 inch) pitches.
- (2) As the CC-Link connector type metal installation fitting, use the narrow-width type (width 41)-dedicated fitting.
 - (a) CC-Link connector type metal installation fitting model
A6PLT-J65V1
- (3) Refer to the Master Module user's manual for the name, specification, and manufacturers of supported cables for the use with AJ65VBTCU-68DAVN.

4.3 Name of Each Part

The name of each part in the AJ65VBTCU-68DAVN is shown.

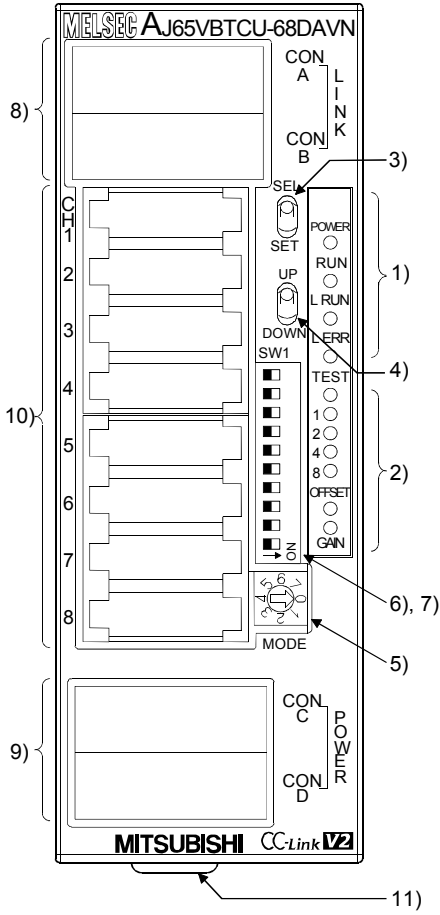

[Pin layout and signals name]

| Pin arrangement | Pin No. | Signal name |
|------------------|---------|-------------|
| CONA CONB | 1 | DA |
| | 2 | DB |
| | 3 | DG |
| | 4 | NC |
| | 5 | SLD |
| CON1 | 1 | CH1 V+ |
| | 2 | NC |
| | 3 | CH1 COM |
| | 4 | NC |
| CON2 | 1 | CH2 V+ |
| | 2 | NC |
| | 3 | CH2 COM |
| | 4 | NC |
| CON3 | 1 | CH3 V+ |
| | 2 | NC |
| | 3 | CH3 COM |
| | 4 | NC |
| CON4 | 1 | CH4 V+ |
| | 2 | NC |
| | 3 | CH4 COM |
| | 4 | NC |
| CON5 | 1 | CH5 V+ |
| | 2 | NC |
| | 3 | CH5 COM |
| | 4 | NC |
| CON6 | 1 | CH6 V+ |
| | 2 | NC |
| | 3 | CH6 COM |
| | 4 | NC |
| CON7 | 1 | CH7 V+ |
| | 2 | NC |
| | 3 | CH7 COM |
| | 4 | NC |
| CON8 | 1 | CH8 V+ |
| | 2 | NC |
| | 3 | CH8 COM |
| | 4 | NC |
| CONC COND | 1 | FG |
| | 2 | +24V(UNIT) |
| | 3 | 24G(UNIT) |
| | 4 | NC |
| | 5 | NC |

A module view from the top

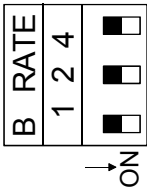
| Number | Name and appearance | Description | | | | | | | | | | | | | | | | | | | | | | | | | | | | | | | | | | |
|--|--|---|--|------------------|--------------------|--|--|--|--|---|------------------------|---|-----|-----|-----|---------|---|-----|-----|----|---------|---|-----|----|-----|---------|---|-----|----|----|---------|---|----|-----|-----|--------|
| 1) | Operation status display LED | POWER | ON : Power supply on OFF : Power supply off | | | | | | | | | | | | | | | | | | | | | | | | | | | | | | | | | |
| | | RUN | <p>Normal mode</p> <p>On : Normal operation Flashing : 0.1s intervals : Output range setting error, mode select switch setting error. This module is used as the Ver.2 remote device station (Ver.2 compatible slave station) when the network parameter mode is set to remote network Ver.1 mode. 0.5s intervals : Average value setting (count) time error. Mode select switch setting is changed after power-on. Off : 24VDC power supply shutoff or watchdog timer error occurred.</p> | | | | | | | | | | | | | | | | | | | | | | | | | | | | | | | | | |
| | | Test mode | <p>On : Indicate that the SELECT/SET switch is in the SET position. Flashing : 0.1s intervals : Mode select switch setting error. 0.5s intervals : An attempt was made to make setting outside the setting range at the time of offset/gain setting. Off : Indicates that the SELECT/SET switch is in the SELECT or center position.</p> | | | | | | | | | | | | | | | | | | | | | | | | | | | | | | | | | |
| | | L RUN | <p>On : Normal communication Off : Communication cutoff (time expiration error)</p> | | | | | | | | | | | | | | | | | | | | | | | | | | | | | | | | | |
| | | L ERR. | <p>On : Indicates that transmission speed setting or station number setting is outside the range. Flicker at fixed intervals : Indicates that transmission speed setting or station number setting was changed from that at power-on. Flicker at unfixed intervals : Indicates that you forgot fitting the terminating resistor or the module or CC-Link dedicated cable is affected by noise. Off : Indicates normal communications.</p> | | | | | | | | | | | | | | | | | | | | | | | | | | | | | | | | | |
| 2) | Offset/gain adjusting LEDs | TEST CH <input type="checkbox"/> | Normal mode : Normally OFF. | | | | | | | | | | | | | | | | | | | | | | | | | | | | | | | | | |
| | | OFFSET GAIN | Test mode : TEST : ON The OFFSET/GAIN/ CH <input type="checkbox"/> LEDs lit change every time the SELECT/SET switch is moved to SELECT. (Refer to section 4.5) | | | | | | | | | | | | | | | | | | | | | | | | | | | | | | | | | |
| 3) | SELECT/SET switch | Used to make offset/gain setting in the test mode. | | | | | | | | | | | | | | | | | | | | | | | | | | | | | | | | | | |
| 4) | UP/DOWN switch | Used to adjust the offset value and gain value of the channel specified by the SELECT/SET switch. | | | | | | | | | | | | | | | | | | | | | | | | | | | | | | | | | | |
| 5) | Mode select switch (Factory-set to "0") | <p>The switch to be used for selecting the mode among Ver. <input type="checkbox"/> remote device station (Ver. <input type="checkbox"/> -compatible slave station)/Normal mode/Test mode</p> <table border="1" data-bbox="427 1317 1417 1563"> <thead> <tr> <th colspan="2">AJ65VBTCU-68DAVN</th> </tr> </thead> <tbody> <tr> <td>Ver.1 remote device station (Ver.1-compatible slave station)</td> <td>0: Normal mode 1: Test mode (User range setting 1) 2: Test mode (User range setting 2)</td> </tr> <tr> <td>Ver.2 remote device station (Ver.2-compatible slave station)</td> <td>3: Normal mode 4: Test mode (User range setting 1) 5: Test mode (User range setting 2)</td> </tr> <tr> <td>-</td> <td>6 to 7: Use prohibited</td> </tr> </tbody> </table> | | AJ65VBTCU-68DAVN | | Ver.1 remote device station (Ver.1-compatible slave station) | 0: Normal mode 1: Test mode (User range setting 1) 2: Test mode (User range setting 2) | Ver.2 remote device station (Ver.2-compatible slave station) | 3: Normal mode 4: Test mode (User range setting 1) 5: Test mode (User range setting 2) | - | 6 to 7: Use prohibited | | | | | | | | | | | | | | | | | | | | | | | | | |
| AJ65VBTCU-68DAVN | | | | | | | | | | | | | | | | | | | | | | | | | | | | | | | | | | | | |
| Ver.1 remote device station (Ver.1-compatible slave station) | 0: Normal mode 1: Test mode (User range setting 1) 2: Test mode (User range setting 2) | | | | | | | | | | | | | | | | | | | | | | | | | | | | | | | | | | | |
| Ver.2 remote device station (Ver.2-compatible slave station) | 3: Normal mode 4: Test mode (User range setting 1) 5: Test mode (User range setting 2) | | | | | | | | | | | | | | | | | | | | | | | | | | | | | | | | | | | |
| - | 6 to 7: Use prohibited | | | | | | | | | | | | | | | | | | | | | | | | | | | | | | | | | | | |
| 6) | <p>Transmission speed setting switches</p>  | <table border="1" data-bbox="427 1585 1417 1841"> <thead> <tr> <th rowspan="2">Set Value</th> <th colspan="3">Setting Switches</th> <th rowspan="2">Transmission Speed</th> </tr> <tr> <th>4</th> <th>2</th> <th>1</th> </tr> </thead> <tbody> <tr> <td>0</td> <td>OFF</td> <td>OFF</td> <td>OFF</td> <td>156kbps</td> </tr> <tr> <td>1</td> <td>OFF</td> <td>OFF</td> <td>ON</td> <td>625kbps</td> </tr> <tr> <td>2</td> <td>OFF</td> <td>ON</td> <td>OFF</td> <td>2.5Mbps</td> </tr> <tr> <td>3</td> <td>OFF</td> <td>ON</td> <td>ON</td> <td>5.0Mbps</td> </tr> <tr> <td>4</td> <td>ON</td> <td>OFF</td> <td>OFF</td> <td>10Mbps</td> </tr> </tbody> </table> <p>Always set the transmission speed within the above range. The switches are all factory-set to OFF. Making any other setting than the above will result in an error flickering the "L ERR." LED. Confirm the transmission speed setting switch numbers on the seal located on the side face of the connector for analog I/O.</p> | | Set Value | Setting Switches | | | Transmission Speed | 4 | 2 | 1 | 0 | OFF | OFF | OFF | 156kbps | 1 | OFF | OFF | ON | 625kbps | 2 | OFF | ON | OFF | 2.5Mbps | 3 | OFF | ON | ON | 5.0Mbps | 4 | ON | OFF | OFF | 10Mbps |
| Set Value | Setting Switches | | | | Transmission Speed | | | | | | | | | | | | | | | | | | | | | | | | | | | | | | | |
| | 4 | 2 | 1 | | | | | | | | | | | | | | | | | | | | | | | | | | | | | | | | | |
| 0 | OFF | OFF | OFF | 156kbps | | | | | | | | | | | | | | | | | | | | | | | | | | | | | | | | |
| 1 | OFF | OFF | ON | 625kbps | | | | | | | | | | | | | | | | | | | | | | | | | | | | | | | | |
| 2 | OFF | ON | OFF | 2.5Mbps | | | | | | | | | | | | | | | | | | | | | | | | | | | | | | | | |
| 3 | OFF | ON | ON | 5.0Mbps | | | | | | | | | | | | | | | | | | | | | | | | | | | | | | | | |
| 4 | ON | OFF | OFF | 10Mbps | | | | | | | | | | | | | | | | | | | | | | | | | | | | | | | | |

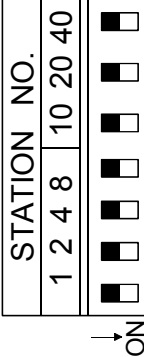
| Number | Name and appearance | Description | | | | | | | | | | | | | | | | | | | | | | | | | | | | | | | | | | | | | | | | | | | | | | | | | | | | | | | | | | | | | | | | | | | | | | | | | | | | | | | | | | | | | | | | | | | | | | | | | | | | | | | | | | | | | | |
|----------------|--|---|----------------|-------|-----|-----|-------|--|--|--|----|----|----|---|---|---|---|---|-----|-----|-----|-----|-----|-----|----|---|-----|-----|-----|-----|-----|----|-----|---|-----|-----|-----|-----|-----|----|----|---|-----|-----|-----|-----|----|-----|-----|---|---|---|---|---|---|---|---|----|-----|-----|----|-----|-----|-----|-----|----|-----|-----|----|-----|-----|-----|----|---|---|---|---|---|---|---|---|----|----|----|-----|-----|----|-----|-----|----------------|------|--|--|-------|--|--|--|----|----|----|---|---|---|---|----|-----|----|----|-----|-----|----|-----|
| 7) | <p>Station number setting switches</p>  | <p>Use the switches in STATION NO. "10", "20" and "40" to set the tens of the station number. Use the switches in STATION NO. "1", "2", "4" and "8" to set the units of the station number. The switches are all factory-set to OFF. Always set the station number within the range 1 to 64. You cannot set the same station number to two or more stations. Setting any other number than 1 to 64 will result in an error, flickering the "L ERR." LED.</p> <table border="1" data-bbox="437 562 1425 958"> <thead> <tr> <th rowspan="2">Station Number</th> <th colspan="3">Tens</th> <th colspan="4">Units</th> </tr> <tr> <th>40</th> <th>20</th> <th>10</th> <th>8</th> <th>4</th> <th>2</th> <th>1</th> </tr> </thead> <tbody> <tr> <td>1</td> <td>OFF</td> <td>OFF</td> <td>OFF</td> <td>OFF</td> <td>OFF</td> <td>OFF</td> <td>ON</td> </tr> <tr> <td>2</td> <td>OFF</td> <td>OFF</td> <td>OFF</td> <td>OFF</td> <td>OFF</td> <td>ON</td> <td>OFF</td> </tr> <tr> <td>3</td> <td>OFF</td> <td>OFF</td> <td>OFF</td> <td>OFF</td> <td>OFF</td> <td>ON</td> <td>ON</td> </tr> <tr> <td>4</td> <td>OFF</td> <td>OFF</td> <td>OFF</td> <td>OFF</td> <td>ON</td> <td>OFF</td> <td>OFF</td> </tr> <tr> <td>:</td> <td>:</td> <td>:</td> <td>:</td> <td>:</td> <td>:</td> <td>:</td> <td>:</td> </tr> <tr> <td>10</td> <td>OFF</td> <td>OFF</td> <td>ON</td> <td>OFF</td> <td>OFF</td> <td>OFF</td> <td>OFF</td> </tr> <tr> <td>11</td> <td>OFF</td> <td>OFF</td> <td>ON</td> <td>OFF</td> <td>OFF</td> <td>OFF</td> <td>ON</td> </tr> <tr> <td>:</td> <td>:</td> <td>:</td> <td>:</td> <td>:</td> <td>:</td> <td>:</td> <td>:</td> </tr> <tr> <td>64</td> <td>ON</td> <td>ON</td> <td>OFF</td> <td>OFF</td> <td>ON</td> <td>OFF</td> <td>OFF</td> </tr> </tbody> </table> <p>(Example) To set the station number to "32", set the switches as indicated below.</p> <table border="1" data-bbox="515 1032 1425 1137"> <thead> <tr> <th rowspan="2">Station Number</th> <th colspan="3">Tens</th> <th colspan="4">Units</th> </tr> <tr> <th>40</th> <th>20</th> <th>10</th> <th>8</th> <th>4</th> <th>2</th> <th>1</th> </tr> </thead> <tbody> <tr> <td>32</td> <td>OFF</td> <td>ON</td> <td>ON</td> <td>OFF</td> <td>OFF</td> <td>ON</td> <td>OFF</td> </tr> </tbody> </table> <p>Confirm the station number setting switch numbers on the seal located on the side face of the connector for analog I/O.</p> | Station Number | Tens | | | Units | | | | 40 | 20 | 10 | 8 | 4 | 2 | 1 | 1 | OFF | OFF | OFF | OFF | OFF | OFF | ON | 2 | OFF | OFF | OFF | OFF | OFF | ON | OFF | 3 | OFF | OFF | OFF | OFF | OFF | ON | ON | 4 | OFF | OFF | OFF | OFF | ON | OFF | OFF | : | : | : | : | : | : | : | : | 10 | OFF | OFF | ON | OFF | OFF | OFF | OFF | 11 | OFF | OFF | ON | OFF | OFF | OFF | ON | : | : | : | : | : | : | : | : | 64 | ON | ON | OFF | OFF | ON | OFF | OFF | Station Number | Tens | | | Units | | | | 40 | 20 | 10 | 8 | 4 | 2 | 1 | 32 | OFF | ON | ON | OFF | OFF | ON | OFF |
| Station Number | Tens | | | Units | | | | | | | | | | | | | | | | | | | | | | | | | | | | | | | | | | | | | | | | | | | | | | | | | | | | | | | | | | | | | | | | | | | | | | | | | | | | | | | | | | | | | | | | | | | | | | | | | | | | | | | | | | | | |
| | 40 | 20 | 10 | 8 | 4 | 2 | 1 | | | | | | | | | | | | | | | | | | | | | | | | | | | | | | | | | | | | | | | | | | | | | | | | | | | | | | | | | | | | | | | | | | | | | | | | | | | | | | | | | | | | | | | | | | | | | | | | | | | | | | | | | |
| 1 | OFF | OFF | OFF | OFF | OFF | OFF | ON | | | | | | | | | | | | | | | | | | | | | | | | | | | | | | | | | | | | | | | | | | | | | | | | | | | | | | | | | | | | | | | | | | | | | | | | | | | | | | | | | | | | | | | | | | | | | | | | | | | | | | | | | |
| 2 | OFF | OFF | OFF | OFF | OFF | ON | OFF | | | | | | | | | | | | | | | | | | | | | | | | | | | | | | | | | | | | | | | | | | | | | | | | | | | | | | | | | | | | | | | | | | | | | | | | | | | | | | | | | | | | | | | | | | | | | | | | | | | | | | | | | |
| 3 | OFF | OFF | OFF | OFF | OFF | ON | ON | | | | | | | | | | | | | | | | | | | | | | | | | | | | | | | | | | | | | | | | | | | | | | | | | | | | | | | | | | | | | | | | | | | | | | | | | | | | | | | | | | | | | | | | | | | | | | | | | | | | | | | | | |
| 4 | OFF | OFF | OFF | OFF | ON | OFF | OFF | | | | | | | | | | | | | | | | | | | | | | | | | | | | | | | | | | | | | | | | | | | | | | | | | | | | | | | | | | | | | | | | | | | | | | | | | | | | | | | | | | | | | | | | | | | | | | | | | | | | | | | | | |
| : | : | : | : | : | : | : | : | | | | | | | | | | | | | | | | | | | | | | | | | | | | | | | | | | | | | | | | | | | | | | | | | | | | | | | | | | | | | | | | | | | | | | | | | | | | | | | | | | | | | | | | | | | | | | | | | | | | | | | | | |
| 10 | OFF | OFF | ON | OFF | OFF | OFF | OFF | | | | | | | | | | | | | | | | | | | | | | | | | | | | | | | | | | | | | | | | | | | | | | | | | | | | | | | | | | | | | | | | | | | | | | | | | | | | | | | | | | | | | | | | | | | | | | | | | | | | | | | | | |
| 11 | OFF | OFF | ON | OFF | OFF | OFF | ON | | | | | | | | | | | | | | | | | | | | | | | | | | | | | | | | | | | | | | | | | | | | | | | | | | | | | | | | | | | | | | | | | | | | | | | | | | | | | | | | | | | | | | | | | | | | | | | | | | | | | | | | | |
| : | : | : | : | : | : | : | : | | | | | | | | | | | | | | | | | | | | | | | | | | | | | | | | | | | | | | | | | | | | | | | | | | | | | | | | | | | | | | | | | | | | | | | | | | | | | | | | | | | | | | | | | | | | | | | | | | | | | | | | | |
| 64 | ON | ON | OFF | OFF | ON | OFF | OFF | | | | | | | | | | | | | | | | | | | | | | | | | | | | | | | | | | | | | | | | | | | | | | | | | | | | | | | | | | | | | | | | | | | | | | | | | | | | | | | | | | | | | | | | | | | | | | | | | | | | | | | | | |
| Station Number | Tens | | | Units | | | | | | | | | | | | | | | | | | | | | | | | | | | | | | | | | | | | | | | | | | | | | | | | | | | | | | | | | | | | | | | | | | | | | | | | | | | | | | | | | | | | | | | | | | | | | | | | | | | | | | | | | | | | |
| | 40 | 20 | 10 | 8 | 4 | 2 | 1 | | | | | | | | | | | | | | | | | | | | | | | | | | | | | | | | | | | | | | | | | | | | | | | | | | | | | | | | | | | | | | | | | | | | | | | | | | | | | | | | | | | | | | | | | | | | | | | | | | | | | | | | | |
| 32 | OFF | ON | ON | OFF | OFF | ON | OFF | | | | | | | | | | | | | | | | | | | | | | | | | | | | | | | | | | | | | | | | | | | | | | | | | | | | | | | | | | | | | | | | | | | | | | | | | | | | | | | | | | | | | | | | | | | | | | | | | | | | | | | | | |
| 8) | One-touch connector for communication | A one-touch connector for connection of the communication line When carrying out wiring, connect two optional one-touch connector plugs for communication at top and bottom. | | | | | | | | | | | | | | | | | | | | | | | | | | | | | | | | | | | | | | | | | | | | | | | | | | | | | | | | | | | | | | | | | | | | | | | | | | | | | | | | | | | | | | | | | | | | | | | | | | | | | | | | | | | | | | |
| 9) | One-touch connector for power supply and FG | A one-touch connector for connection of the module power supply line and FG When carrying out jumper wiring, connect two optional one-touch connector plugs for power supply and FG at top and bottom. | | | | | | | | | | | | | | | | | | | | | | | | | | | | | | | | | | | | | | | | | | | | | | | | | | | | | | | | | | | | | | | | | | | | | | | | | | | | | | | | | | | | | | | | | | | | | | | | | | | | | | | | | | | | | | |
| 10) | One-touch connector for analog I/O | One-touch connector for analog I/O Connect a one-touch connector plug when wiring. | | | | | | | | | | | | | | | | | | | | | | | | | | | | | | | | | | | | | | | | | | | | | | | | | | | | | | | | | | | | | | | | | | | | | | | | | | | | | | | | | | | | | | | | | | | | | | | | | | | | | | | | | | | | | | |
| 11) | DIN rail hook | Used to mount the module to the DIN rail. | | | | | | | | | | | | | | | | | | | | | | | | | | | | | | | | | | | | | | | | | | | | | | | | | | | | | | | | | | | | | | | | | | | | | | | | | | | | | | | | | | | | | | | | | | | | | | | | | | | | | | | | | | | | | | |

| |
|---|
| POINT |
| After power-on, do not change the mode select switch setting. If you change it midway during operation, the setting at power-on is valid. |

4.4 Concept of Mode Select Switch Setting (Selection of Remote Device Station Compatible Version)

The AJ65VBTCU-68DAVN must be handled after setting of the remote device station version according to the configuration of the used CC-Link system.

There are the following remote device stations.

- Ver. 1 remote device station (Ver. 1 compatible slave station)
- Ver. 2 remote device station (Ver. 2 compatible slave station)

Set the remote device station version with the "mode select switch" of the AJ65VBTCU-68DAVN. Refer to Section 4.3 for details of the mode select switch. In addition, "mode setting" and "station information (station type)" in the network parameters of GX Developer must be set simultaneously. For details, refer to (2) in this section and Chapter 5 Programming.

(1) Basic concept

Use the following as a guideline in setting the remote device station version and mode select switch.

| Mode Select Switch Setting | Guideline for Selection |
|--|---|
| Ver. 1 remote device station (Ver. 1 compatible slave station) Number of occupied stations: 3 stations | In the case of the system where the maximum number of connected stations of the master station, including the AJ65VBTCU-68DAVN that occupies 3 stations, does not exceed 64 stations. |
| Ver. 2 remote device station (Ver. 2 compatible slave station) Number of occupied stations: 1 station | In the case of the system where the maximum number of connected stations of the master station, including the AJ65VBTCU-68DAVN that occupies 3 stations, exceeds 64 stations. (However, configure a system where the maximum number of connected stations of the master station, including the AJ65VBTCU-68DAVN that occupies 1 station, will not exceed 64 stations.) |

| POINT |
|---|
| In the case of the system where the maximum number of connected stations of the master station, including the AJ65VBTCU-68DAVN that occupies 3 stations, does not exceed 64 stations, set and use the ver. 1 remote device station (ver. 1 compatible slave station). It is not particularly necessary to set and use the ver. 2 remote device station (ver. 2 compatible slave station). |

(2) Applicable combinations and setting concepts

The following table indicates usability according to the combinations of the master modules, the mode setting and station information (station type) of the GX Developer network parameters, and the mode select switch setting of the module. Refer to the following table and make selection.

○: Usable, ×: Unusable

| Master Module | GX Developer Network Parameter Setting | | Model Select Switch Setting of AJ65VBTCU-68DAVN | |
|--|--|------------------------------------|--|--|
| | Mode setting | Station information (station type) | Ver. 1 remote device station (Ver. 1 compatible slave station) | Ver. 2 remote device station (Ver. 2 compatible slave station) |
| QJ61BT11 AJ61BT11 A1SJ61BT11 AJ61QBT11 A1SJ61QBT11 | Remote net ver. 1 mode | Remote device station | ○ Concept A | × |
| | Remote net ver. 2 mode | Ver. 1 remote device station | × | × |
| | | Ver. 2 remote device station | | |
| Remote net additional mode | Ver. 1 remote device station Ver. 2 remote device station | | | |
| QJ61BT11N L26CPU-BT LJ61BT11 | Remote net ver. 1 mode | Remote device station | ○ Concept B | × |
| | Remote net ver. 2 mode | Ver. 1 remote device station | ○ Concept C | × |
| | | Ver. 2 remote device station | × | ○ Concept D |
| | Remote net additional mode | Ver. 1 remote device station | ○ Concept E | × |
| Ver. 2 remote device station | | × | ○ Concept F | |

| Setting Concept | Outline |
|-----------------|---|
| Concept A | Select this concept when system expansion is not necessary. Select this concept when the module replaces the conventional one as a maintenance product. |
| Concept B | Select this concept when system expansion is not necessary. Select this concept when the module replaces the conventional one as a maintenance product. |
| Concept C | Select this concept when configuring a new system. The ver. 1 compatible slave station and ver. 2 compatible slave station can be mixed. The ver. 1 remote device station occupies 3 stations. |
| Concept D | Select this concept when configuring a new system. The ver. 1 compatible slave station and ver. 2 compatible slave station can be mixed. The ver. 2 remote device station occupies 1 station, and can connect more devices. Refer to Chapter 5 Programming. |
| Concept E | This concept allows this module to be newly added to the existing system. When there is a station number used as the ver. 2 remote device station in the existing system, set the station number of the ver. 1 remote device station to be added before that station. The ver. 1 remote device station occupies 3 stations. |
| Concept F | This concept allows this module to be newly added to the existing system. Set the station number of the ver. 2 remote device station to be added after the station numbers used in the existing system. The ver. 2 remote device station occupies 1 station, and can connect more devices. Refer to Chapter 5 Programming. |

| POINT |
|--|
| For use in the remote net ver. 2 mode or remote net additional mode, the master module of QJ61BT11N and the peripheral software package of GX Developer Version 8.03D or later are required. For more information on the applicable modules (CPU modules, network modules) and applicable software packages, refer to the CC-Link System Master/Local Module User's Manual (Details) QJ61BT11N. |

4.5 Offset/Gain Setting

When changing the I/O conversion characteristics, follow the procedure below.

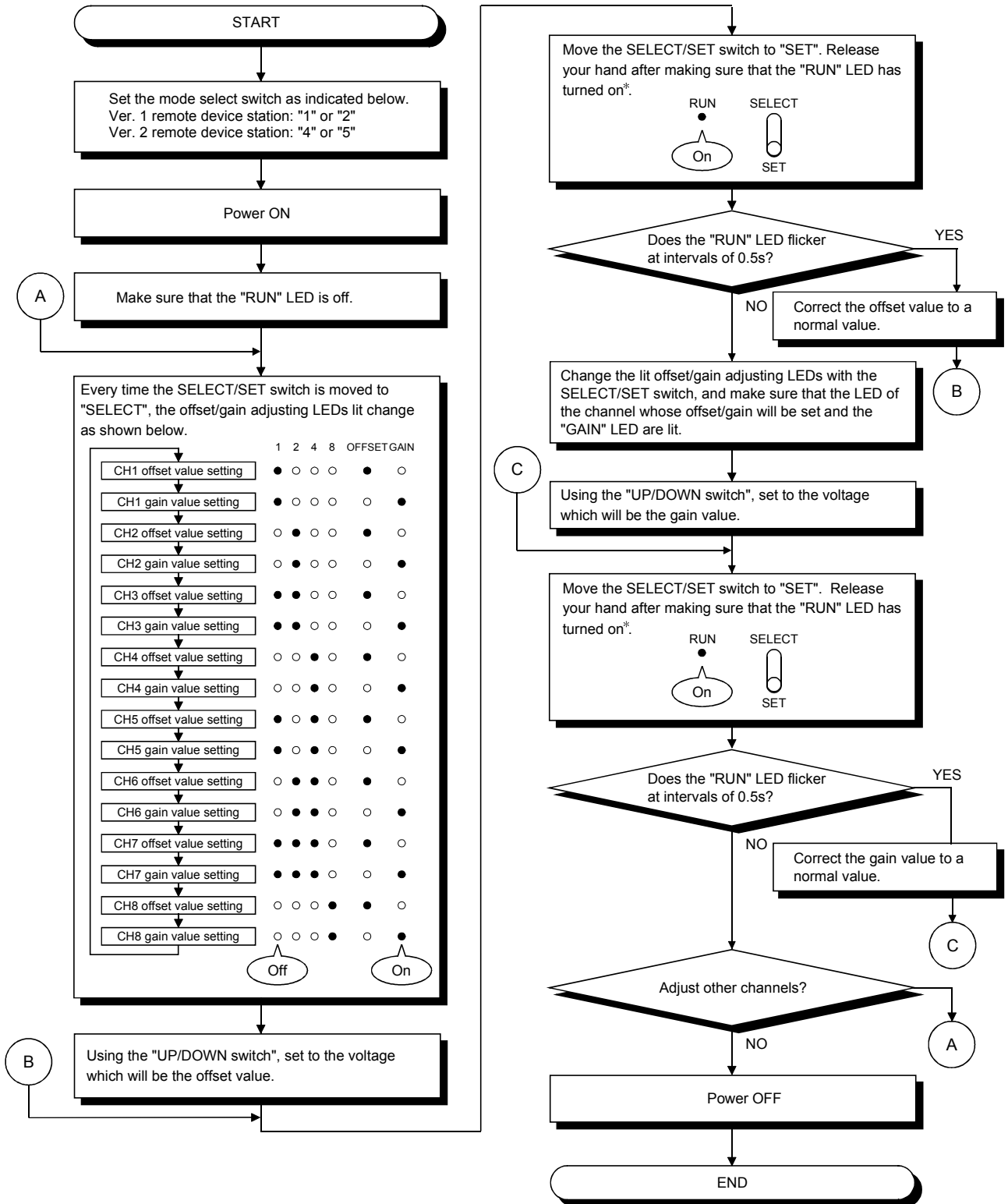

| POINT |
|--|
| <p>(1) Set the offset and gain values in the actual usage state.</p> <p>(2) The offset and gain values are stored on E²PROM in the AJ65VBTCU-68DAVN and are not cleared at power-off.</p> <p>(3) Make offset/gain setting within the range indicated in POINT of Section 3.3.1 and Section 3.3.2. If setting is made outside this range, the maximum resolution/accuracy may not fall within the performance specifications range.</p> <p>(4) When making offset/gain setting (in the test mode), set any of the following test modes with the mode select switch.</p> <p style="padding-left: 40px;">AJ65VBTCU-68DAVN (Ver. 1 remote device station): 1, 2</p> <p style="padding-left: 40px;">AJ65VBTCU-68DAVN (Ver. 2 remote device station): 4, 5</p> <p>The user range settings 1 selected with the mode select switch set to 1 and 4 are the same. The setting of the user range setting 1 can be changed by setting the mode select switch to either 1 or 4. This also applies to the user range settings 2 selected with the mode select switch set to 2 and 5.</p> <p>If the switch has been set to any unusable number, an error occurs and the "RUN" LED flickers at intervals of 0.1s.</p> |

4.6 Section Number Setting

The station number setting of the AJ65VBTCU-68DAVN determines the buffer memory addresses of the master module where the remote I/O signals and read/write data are stored.

For details, refer to the user's manual of the master module used.

4.7 Facing Direction of the Module Installation

The AJ65VBTCU-68DAVN module may be installed in any of six orientations using a DIN rail or CC-Link connector type fitting.
(There are no restrictions on the facing directions.)

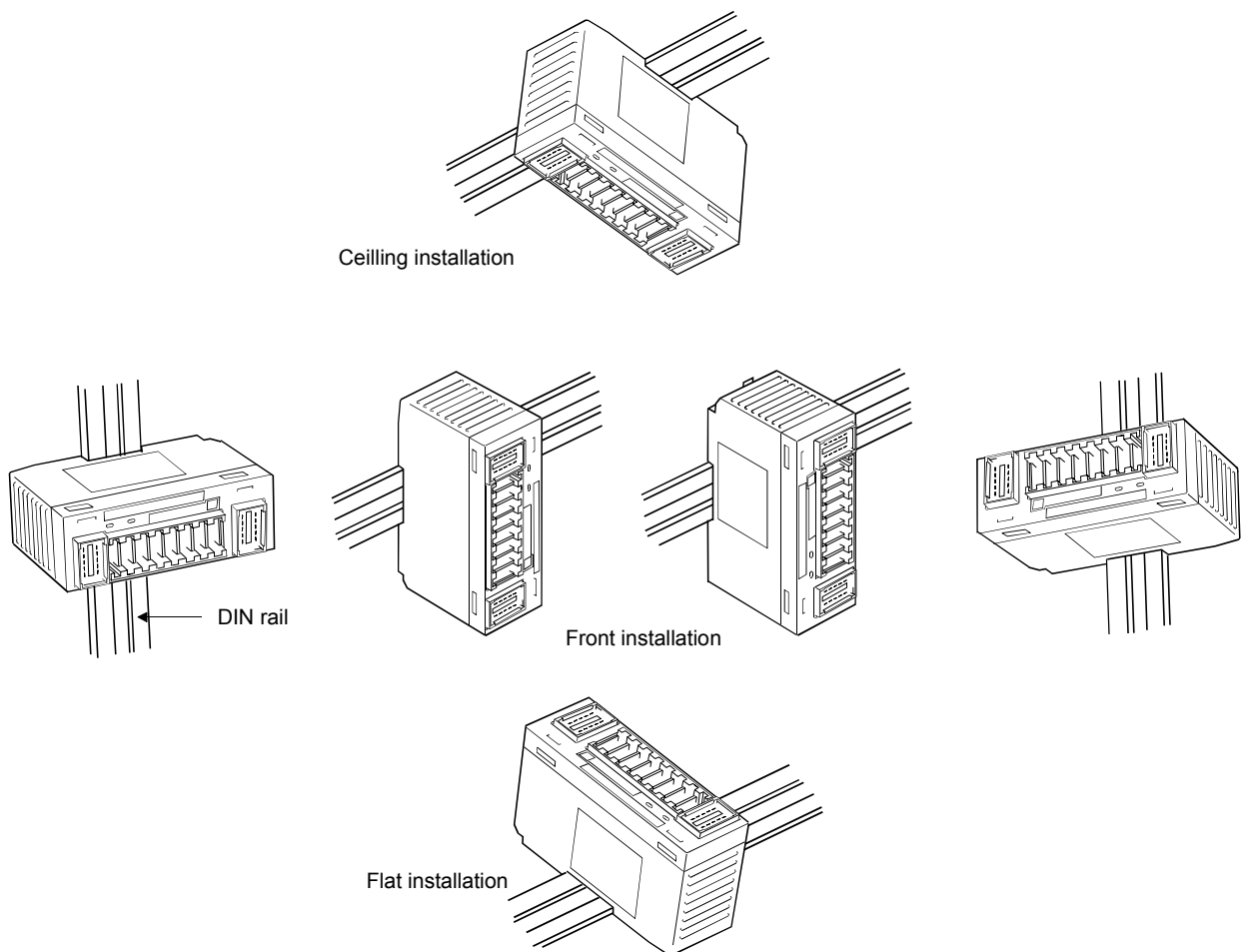

4.8 Data Link Cable Wiring

This section explains the wiring of the CC-Link dedicated cable used for connection of the AJ65VBTCU-68DAVN and master module.

4.8.1 Connection of the CC-Link dedicated cables

Connect the CC-Link dedicated cable between the AJ65VBTCU-68DAVN and master module as shown below.

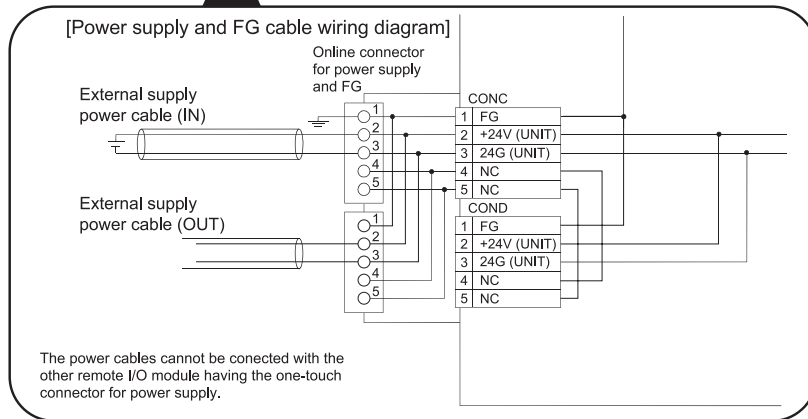
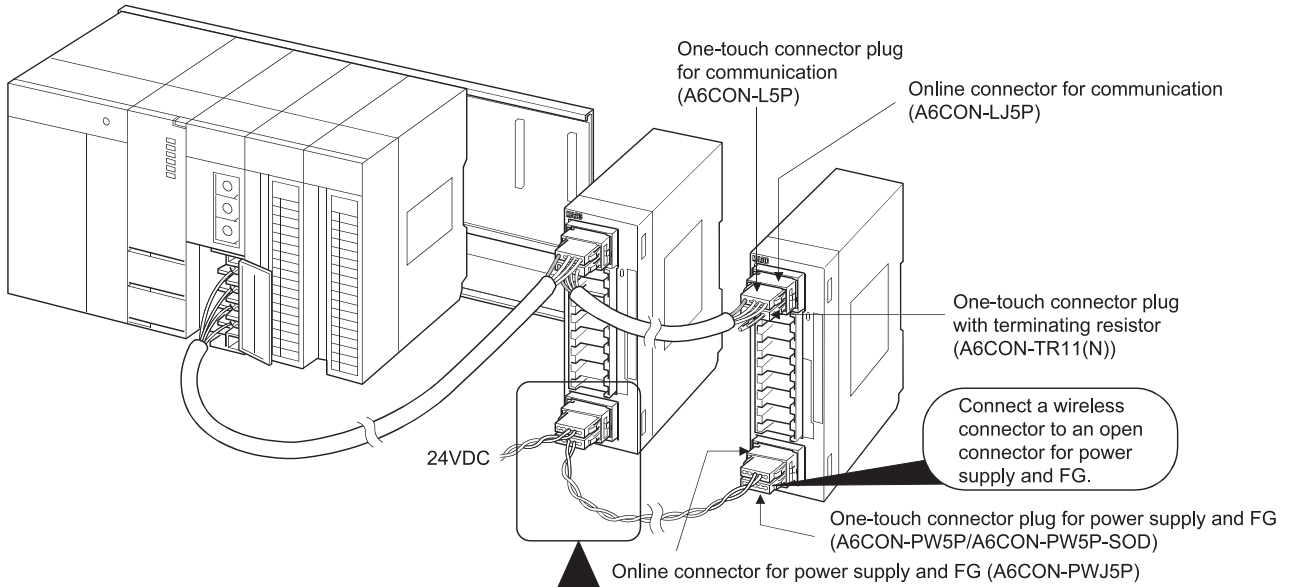

[CC-Link dedicated cable wiring diagram]

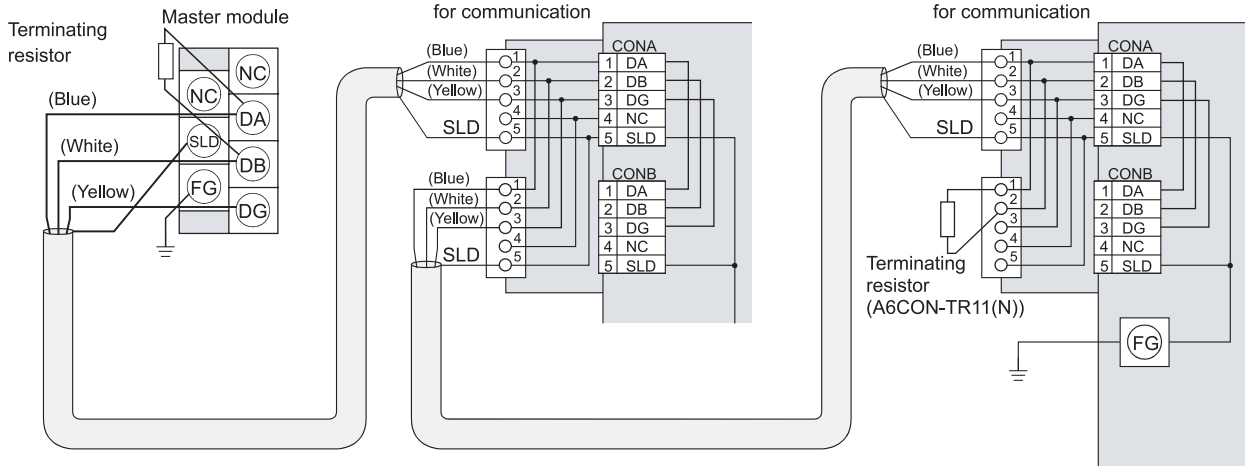

Ver.1.10 Compatible CC-Link dedicated cable (FANC-110SBH,CS-110,FA-CBL200PSBH)

POINT

- On this unit, use the Ver. 1.10-compatible CC-Link dedicated cable (FANC-110SBH, CS-110, FA-CBL200PSBH).
You cannot use the Ver. 1.10-compatible CC-Link dedicated cables of other than the above types, CC-Link dedicated cables and CC-Link dedicated, high-performance cables.
- The shield cable of the CC-Link dedicated cable should be connected to "SLD" in each module, and both ends should be grounded through "FG".
SLD and FG are connected inside the module.

4.8.2 How to connect connectors

The following shows how to connect the one-touch connectors and online connectors.

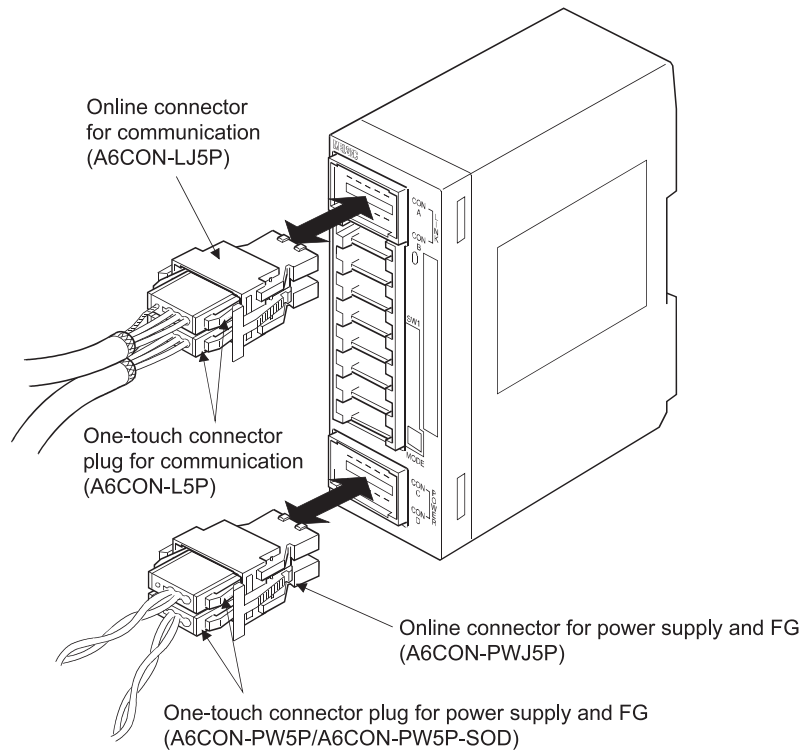
**POINT**

For how to connect/disconnect the online connectors, refer to the manuals included with the connectors.

4.9 Wiring

This section provides the instructions for wiring the AJ65VBTCU-68DAVN and its wiring with external equipment.

4.9.1 Wiring precautions

To obtain maximum performance from the functions of AJ65VBTCU-68DAVN and improve the system reliability, an external wiring with high durability against noise is required.

The precautions when performing external wiring are as follows:

- (1) Use separate cables for the AC and AJ65VBTCU-68DAVN external output signals, in order not to be affected by the AC side surge or conductivity.
- (2) Do not bundle or place with load carrying wires other than the main circuit line, high voltage line or programmable controller. Noises, surges, or conductivity may affect the system.
- (3) Place a one-point grounding on the programmable controller side for the shielded line or shielded cable.
- (4) Smoke and fire may occur when an overcurrent flows intermittently for a long period of time. To avoid this, configure a safety circuit, such as an external fuse, to protect the product.

4.9.2 Wiring of module with external equipment

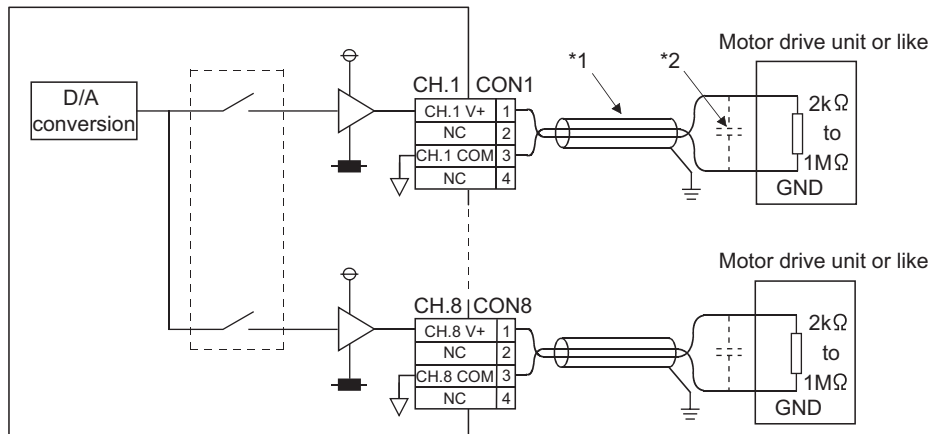

*1 Use a two-core twist shielded line for the wiring.

*2 If noise or ripples occur in the external wiring, connect a 0.1 to 0.47 μ F capacitor (25V or higher voltage-resistant product) to the input terminals of the external device.

| |
|--------------|
| POINT |
|--------------|

- | |
|---|
| <ul style="list-style-type: none"> • D/A conversion needs to be powered on 30 minutes prior to operation for compliance to the specification (accuracy). • Do not insert the one-touch connector plug for I/O of the one-touch connector type/connector type compact remote I/O unit into the one-touch connector for analog I/O accidentally. Doing so can cause the module to be damaged. |
|---|

4.10 How to Wire the One-Touch Connector Plug

This section describes the way to wire the one-touch connector plug. Refer to section 2.4 for more information on the types and specifications of the one-touch connector plugs which conform to the AJ65VBTCU-68DAVN.

4.10.1 Precautions for the transition wiring of the one-touch connector for power supply and FG

When the power supply is connected in the transition wiring with the one-touch connector for power supply and FG, a current flows in the inside of the module. At the transition wiring, the maximum rated current must be lower than the following values. Smoke and fire may occur when an overcurrent at the rated value or higher flows intermittently for a long period of time. To avoid this, configure a safety circuit, such as an external fuse, to protect the product.

Depending on the operation characteristics of the fuse etc., a current which exceeds considerably the rating may flow. Therefore, in order to avoid the damage on the module, make a selection with enough safety allowance, considering the following maximum rated current.

| No. | Power supply port name | Power supply port | Maximum rated current |
|-----|--------------------------|---|-----------------------|
| 1) | Module power supply (IN) | One-touch connector for power supply and FG (CONC-2, 3 pin) | 7A*1 |

| No. | Power supplied by the power supply port | Description of the power supplies | Maximum consumption current |
|-----|---|--|---|
| 2) | Module power supply (IN) | Power supply for operating the CC-Link module | Refer to the external power supply consumption current values in the module specifications. |
| 3) | Module power supply (OUT) | Power which supplies the module and external devices connected in the module transition wiring | According to the connected module and external device. |

*1 Configure 1) so that 2) + 3) is lower than the maximum rated current (7A).

System example

Digital-analog converter module (example: AJ65VBTCU-68DAVN)

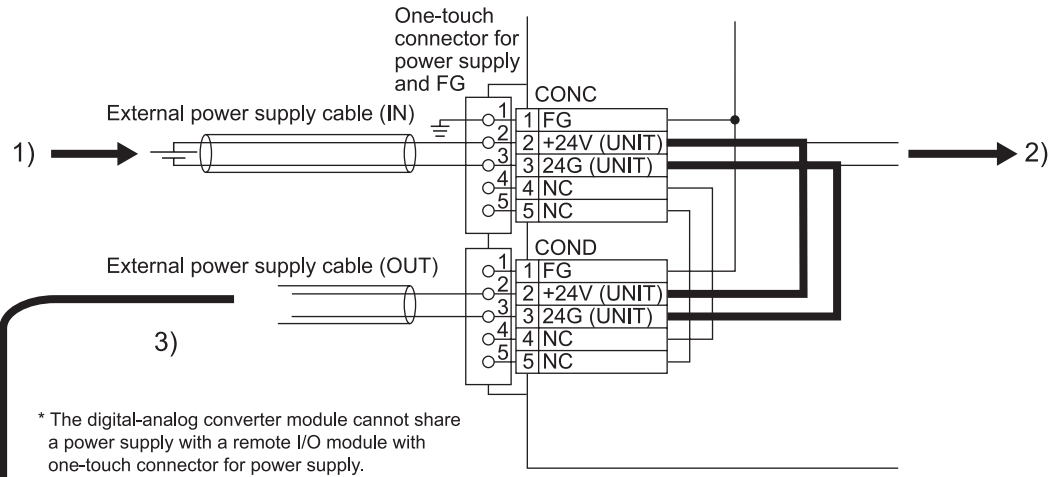

Digital-analog converter module (example: AJ65VBTCU-68DAVN)

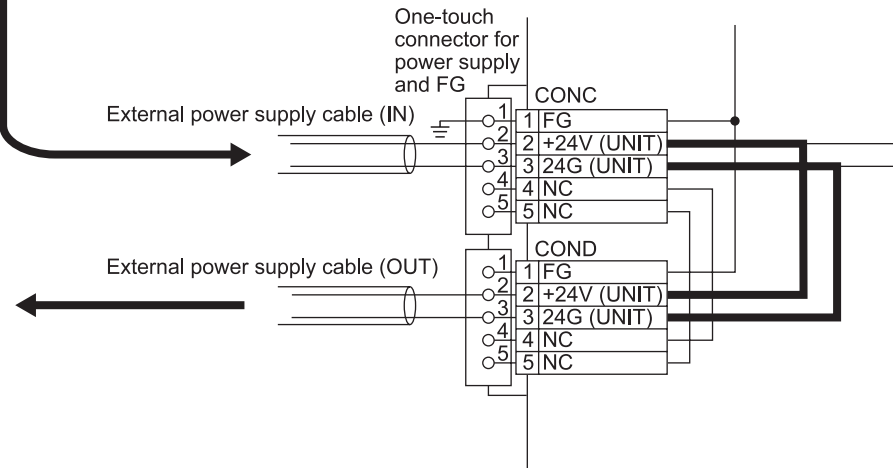

4.10.2 Wiring procedures for the one-touch connector

The following are the wiring procedures for the one-touch connector.

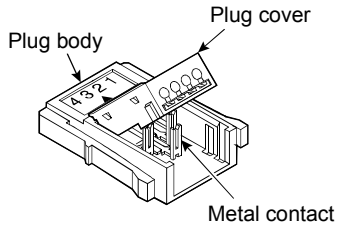

- 1) Check the connector.
Check that the plug cover is attached to the plug body.

Note: Do not push the plug cover into the plug body.
Once pressed, the plug cannot be used any more.

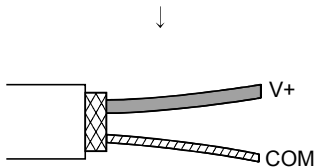

- 2) Processing for analog output cable
Strip the cable 3cm or more, cut the outer sheath and then the shielded wires to the proper length.
If the electric wire lengths are not even, trim their ends with a nipper to the same length so as to insert them neatly into a connector.

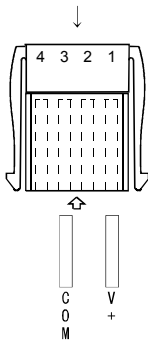

- 3) Insert the cable.
Lift the end of the plug cover and insert the cable until it almost reaches the plug body (within 1mm from the other end of the plug cover).
Insufficient cable insertion may cause improper press fitting.

Note: When inserting the cable, prevent the cable from sticking out from the plug cover end.

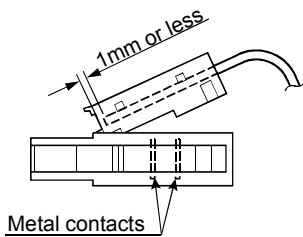

(To the next page)

(From the previous page)

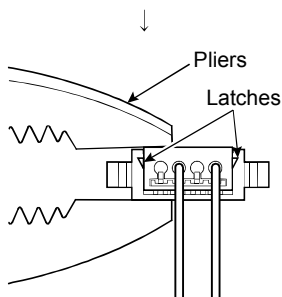
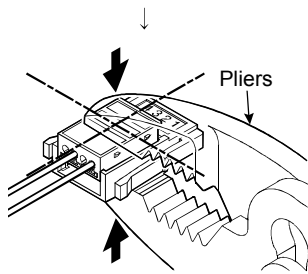
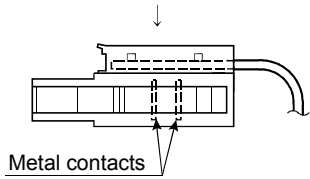

[Correct example]

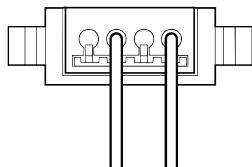

[Wrong example]

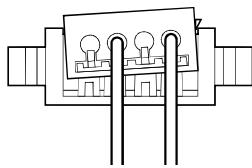

(To the next page)

- 4) Set the plug cover.

After inserting the cable, put down the plug cover so that its face is horizontal to the plug surface, allowing the metal contacts to be fitted into the plug cover.

- 5) Press the center part of the plug cover.

Using pliers, press the center part of the plug cover vertically and strongly.

For the one-touch connectors, use adjustable pliers so that their jaws can be widely opened.

- 6) Press both ends of the plug cover

After pressing the center part of the plug cover, press both ends of the plug cover where latches are located.

Verify that the latches engage with the plug body.

- 7) Check the press-fit condition (viewing from the wiring side).

Viewing from the wiring side, check that the plug surface is flush with the plug cover.

Do not allow the plug cover to protrude from the plug surface.

Note: The condition where the plug cover is tilted or protrudes from the plug surface as shown in [Wrong example] is an improper press-fit condition.

Press the plug cover firmly with pliers until it looks like [Correct example] condition illustrated on the left.

(From the previous page)



[Correct example]

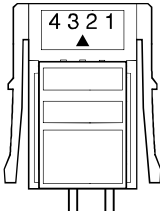

[Wrong example]

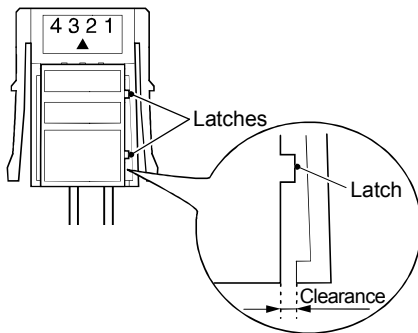

(Wiring completed)

- 8) Check the press-fit condition (viewing from the top).
Viewing from the top, check that there is no clearance between the plug body and plug cover.

Note: Clearance may occur between the plug body and plug cover when the latches do not engage securely as shown in [Wrong example].

Press the plug cover firmly with pliers until it looks like [Correct example] condition illustrated on the left.

4.10.3 Wiring procedures for the one-touch connector for communication

This section provides the wiring procedures of the one-touch connector for communication.

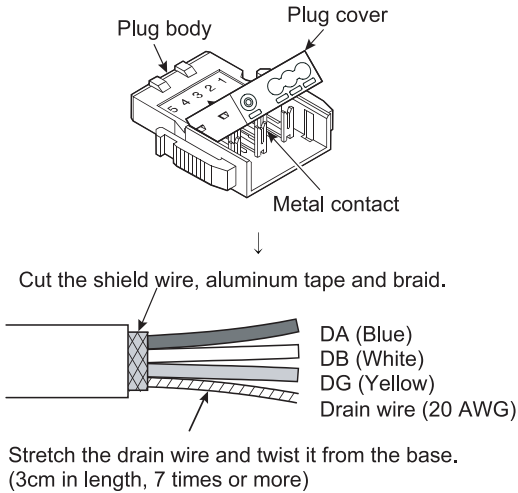

- 1) Check the connector.
Check that the plug cover is attached to the plug body.
- Note: Do not push the plug cover into the plug body.
Once pressed, the plug cannot be used any more.

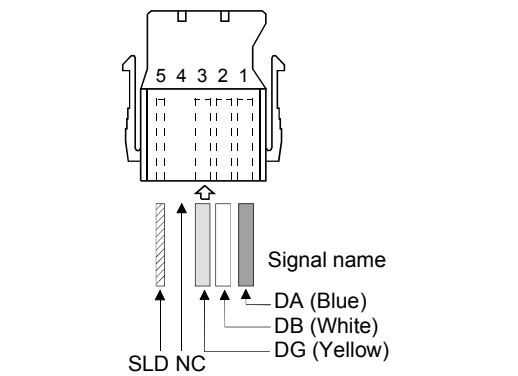

- 2) Processing for communication cable
Strip the cable 3cm or more and perform the processing indicated at left.
If the electric wire lengths are not even, trim their ends with a nipper to the same length so as to insert them neatly into a connector.
- 3) Insert the cable.
Lift the end of the plug cover and insert the cable until it reaches the other end of the cover.
Insufficient cable insertion may cause improper press fitting.

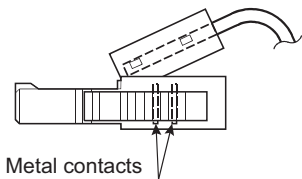

- 4) Set the plug cover.
After inserting the cable, put down the plug cover so that its face is horizontal to the plug surface, allowing the metal contacts to be fitted into the plug cover.

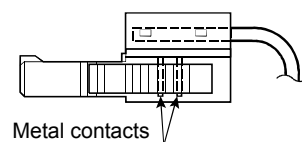

- 5) Press the center part of the plug cover.
Using pliers, press the center part of the plug cover vertically and strongly.

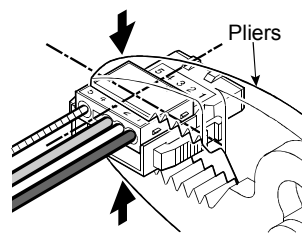

(To the next page)

(From the previous page)

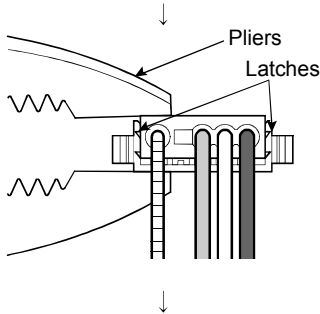

[Correct example]

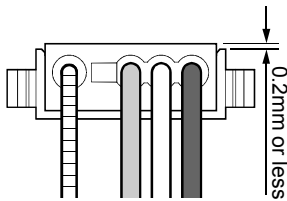

[Wrong example]

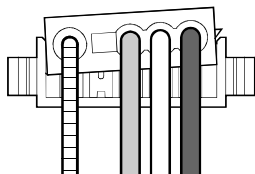

[Correct example]

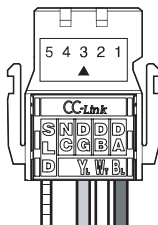

[Wrong example]

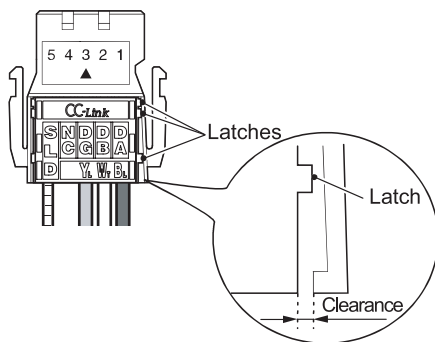

(Wiring completed)

- 6) Press both ends of the plug cover
After pressing the center part of the plug cover, press both ends of the plug cover where latches are located. Verify that the latches engage with the plug body.

- 7) Check the press-fit condition (viewing from the wiring side).
Viewing from the wiring side, check that the plug surface is flush with the plug cover. The difference between the plug cover and the plug surface must be 0.2mm or less.

Note: The condition where the plug cover is tilted as shown in [Wrong example] or protrudes from the plug surface 0.2mm or more is an improper press-fit condition. Press the plug cover securely with pliers until it looks like [Correct example] condition illustrated on the left.

- 8) Check the press-fit condition (viewing from the top).
Viewing from the top, check that there is no clearance between the plug body and plug cover.

Note: Clearance may occur between the plug body and plug cover when the latches do not engage securely as shown in [Wrong example]. Press the plug cover firmly with pliers until it looks like [Correct example] condition illustrated on the left.

4.10.4 Wiring procedures for the one-touch connector for power supply and FG

The following are the wiring procedures for the one-touch connector used for power supply and FG.

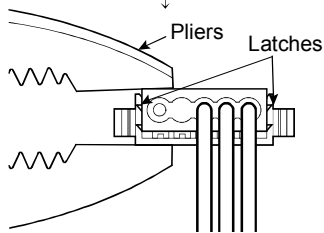
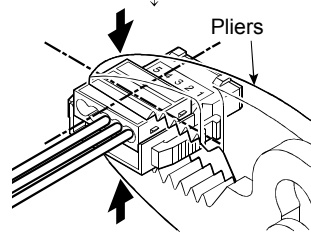
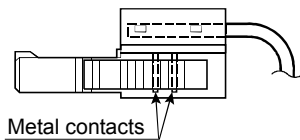
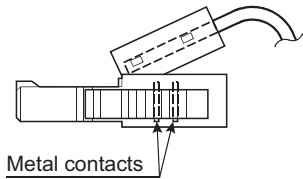
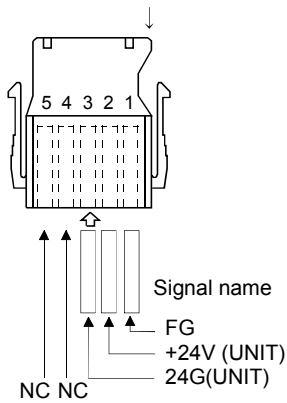
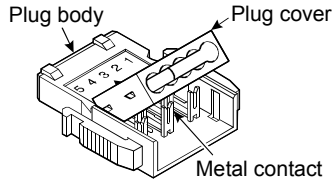

(To the next page)

- 1) Check the connector.
Check that the plug cover is attached to the plug body.

Note: Do not push the plug cover into the plug body.
Once pressed, the plug cannot be used any more.

- 2) Insert the cable.
Lift the end of the plug cover and insert the cable until it reaches the other end of the cover.
Insufficient cable insertion may cause improper press fitting.

- 3) Set the plug cover.
After inserting the cable, put down the plug cover so that its face is horizontal to the plug surface, allowing the metal contacts to be fitted into the plug cover.

- 4) Press the center part of the plug cover.
Using pliers, press the center part of the plug cover vertically and strongly.

For the one-touch connector for power supply and FG, use adjustable pliers so that their jaws can be widely opened.

- 5) Press both ends of the plug cover
After pressing the center part of the plug cover, press both ends of the plug cover where latches are located.
Verify that the latches engage with the plug body.

(From the previous page)

[Correct example]

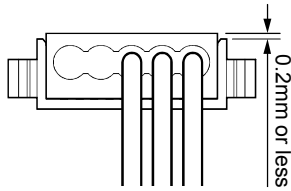

[Wrong example]

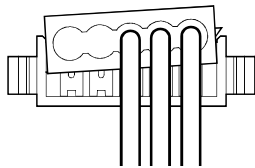

- 6) Check the press-fit condition (viewing from the wiring side).
Viewing from the wiring side, check that the plug surface is flush with the plug cover.
Set the plug cover so that it protrudes 0.2mm or less from the plug surface.

Note: The condition where the plug cover is tilted or protrudes 0.2mm or more from the plug surface as shown in [Wrong example] is an improper press-fit condition.
Press the plug cover firmly with pliers until it looks like [Correct example] condition illustrated on the left.

[Correct example]

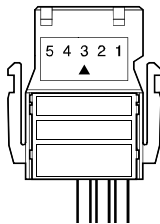

[Wrong example]

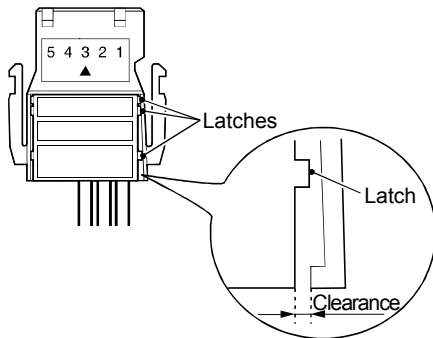

- 7) Check the press-fit condition (viewing from the top).
Viewing from the top, check that there is no clearance between the plug body and plug cover.

Note: Clearance may occur between the plug body and plug cover when the latches do not engage securely as shown in [Wrong example].
Press the plug cover firmly with pliers until it looks like [Correct example] condition illustrated on the left.

(Wiring completed)

*1 When using a cabtyre cable:

Strip the cable 2cm or more.

If the electric wire lengths are not even, trim their ends with a nipper to the same length so as to insert them neatly into a connector.

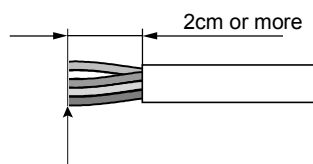

Trim the wire ends to the same length

4.11 Maintenance and Inspection

There are no special inspection items for the AJ65VBTCU-68DAVN module, but follow the inspections items describes in the programmable controller CPU User's Manual so that the system can always be used in the best condition.

5 PROGRAMMING

The programming procedure, basic read/write programs, and program examples for the AJ65VBTCU-68DAVN are described.

When utilizing the program example introduced in this chapter for an actual system, fully verify that there are no problems in controllability in the target system.

Refer to the user's manual of the master module used for the master module, to Section 3.6 for the remote registers, and to the AnSHCPU/AnACPU/AnUCPU/QCPU (A mode) Programming Manual (Dedicated Instructions) for details of the dedicated instructions.

5.1 Programming Procedure

Create programs for executing the digital-analog conversion of the AJ65VBTCU-68DAVN in the following procedure.

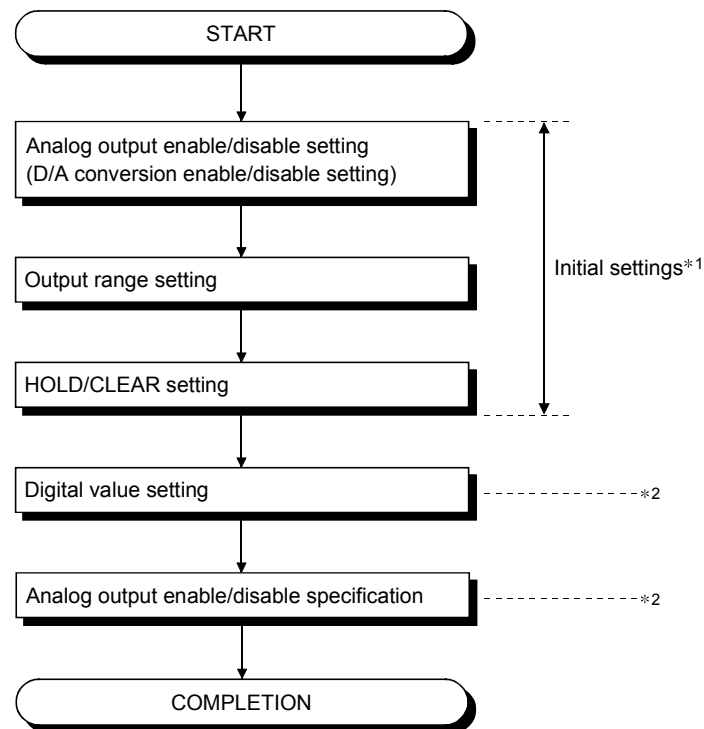

*1 When using the QCPU (Q mode), you can use the remote device station initialization procedure registration function to make settings. When using the ACPU, QCPU (A mode) or QnACPU, use the sequence program to make settings.

*2 The remote device station initialization procedure registration function cannot be used to make settings.
Use the sequence program to make settings.

5.2 When Remote Net Ver. 1 Mode Is Used

5.2.1 Conditions of Program Example

The program examples in this section are created under the following conditions.

(1) System configuration

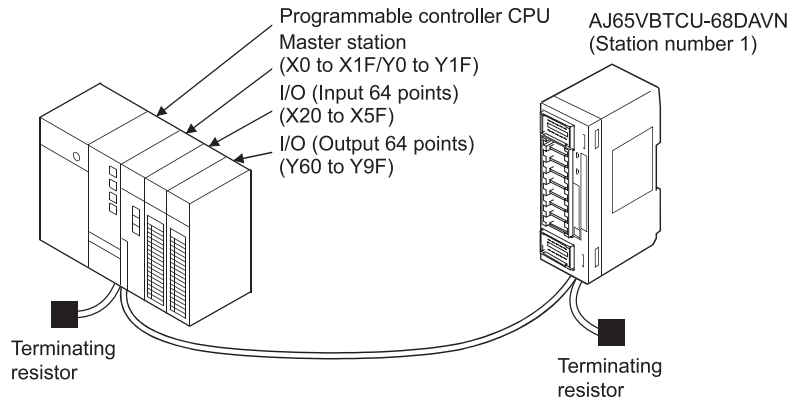

(2) Relationships between programmable controller CPU, master module and AJ65VBTCU-68DAVN

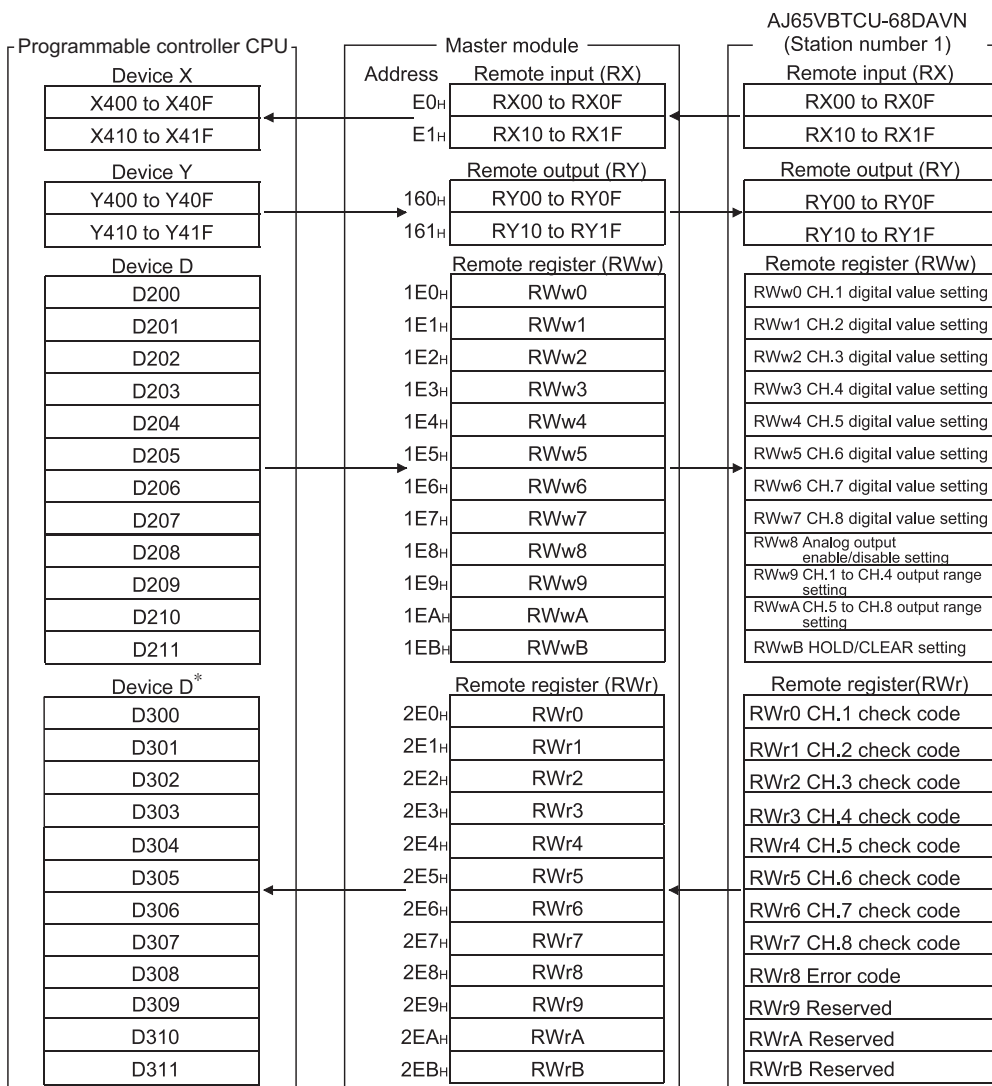

* In the program example (refer to Section 5.2.4) that uses the RRPA instruction (automatic refresh parameter setting) with the ACPU/QCPU (A mode), RWr0 to RWr8 are assigned to D456 to D464.

POINT

Some CPU modules may not accept the devices used in the program example in this chapter. For the setting ranges of the devices, refer to the user's manual of the CPU module used. For the A1SCPU, for example, devices X100, Y100 and later are unusable. Use such devices as B and M.

(3) Initial settings

| Setting Item | Settings |
|---|---|
| Analog output enable/disable setting (RWw2) | Channels 1, 2: enable |
| CH. 1 to CH. 4 output range setting (RWw9) | Channel 1: 0 to 5V Channel 2: user range setting 1 |
| HOLD/CLEAR setting (RWwB) | Channels 1, 2: CLEAR |

(4) Other settings

| Setting Item | Settings |
|---|----------|
| CH.1 digital value (RWw0) | 500 |
| CH.2 digital value (RWw1) | 1000 |
| CH.1 analog output enable/disable frag (RY00) | Enable |
| CH.2 analog output enable/disable frag (RY01) | Enable |

5.2.2 Program Example for Use of the QCPU (Q mode)

The program examples in this section are created under the following conditions. GX Developer is used to set the network and automatic refresh parameters. Using the remote device station initialization procedure registration function facilitates initial settings.

- (1) Parameter setting
 - (a) Network parameter setting

| | |
|---|----------------------------|
| 1 | |
| Start I/O No. | 0000 |
| Operational setting Operational settings | |
| Type | Master station ▼ |
| Master station data link type | PLC parameter auto start ▼ |
| Mode | Remote net(Ver.1 mode) ▼ |
| All connect count | 1 |
| Remote input(RX) | |
| Remote output(RY) | |
| Remote register(RW/r) | |
| Remote register(RW/w) | |
| Ver.2 Remote input(RX) | |
| Ver.2 Remote output(RY) | |
| Ver.2 Remote register(RW/r) | |
| Ver.2 Remote register(RW/w) | |
| Special relay(SB) | |
| Special register(SW) | |
| Retry count | 3 |
| Automatic reconnection station count | 1 |
| Stand by master station No. | |
| PLC down select | Stop ▼ |
| Scan mode setting | Asynchronous ▼ |
| Delay information setting | 0 |
| Station information setting Station information | |
| Remote device station initial setting Initial settings | |
| Interrupt setting Interrupt settings | |

| Station No. | Station type | Expanded cyclic setting | Exclusive station count | Remote station points | Reserve/invalid station select | Intelligent buffer select(word) ▲ | | |
|-------------|-------------------------|-------------------------|-------------------------|-----------------------|--------------------------------|-----------------------------------|---------|-----------|
| | | | | | | Send | Receive | Automatic |
| 1/1 | Remote device station ▼ | single ▼ | Exclusive station 3 ▼ | 96 points ▼ | No setting ▼ | | | |

- (b) Automatic refresh parameter setting

| | |
|---|----------------------------|
| 1 | |
| Start I/O No. | 0000 |
| Operational setting Operational settings | |
| Type | Master station ▼ |
| Master station data link type | PLC parameter auto start ▼ |
| Mode | Remote net(Ver.1 mode) ▼ |
| All connect count | 1 |
| Remote input(RX) | X400 |
| Remote output(RY) | Y400 |
| Remote register(RW/r) | D300 |
| Remote register(RW/w) | D200 |
| Ver.2 Remote input(RX) | |
| Ver.2 Remote output(RY) | |
| Ver.2 Remote register(RW/r) | |
| Ver.2 Remote register(RW/w) | |
| Special relay(SB) | SB0 |
| Special register(SW) | SW0 |
| Retry count | 3 |
| Automatic reconnection station count | 1 |
| Stand by master station No. | |
| PLC down select | Stop ▼ |
| Scan mode setting | Asynchronous ▼ |
| Delay information setting | 0 |
| Station information setting Station information | |
| Remote device station initial setting Initial settings | |
| Interrupt setting Interrupt settings | |

(2) Initial setting by remote device station initialization procedure registration

(a) Setting the target station number

Set the station number to which initial setting will be made.
Set the target station number to "1".

| Remote device station initial setting: Target station number setting: Module 1 | | | | | | | |
|--|--------------------|------------------------------|------------------|----|--------------------|------------------------------|------------------|
| | Target station No. | No. of registered procedures | | | Target station No. | No. of registered procedures | |
| | 1 | 1 | Regist procedure | 9 | | | Regist procedure |
| | 2 | | Regist procedure | 10 | | | Regist procedure |

(b) Setting the procedure registration

When the initial data processing request flag (RX18) turns on and the remote device station initialization procedure registration (SB0D) is set, the following data are registered to the AJ65VBTCU-68DAVN.

| Procedure Execution Condition | Execution |
|---|---|
| Initial data processing request flag (RX18) turns on | Analog output enable/disable setting: channels 1, 2: enable (RWw8 :00FC _H) |
| | CH.1 to CH.4 output range setting : channel 1: 0 to 5V : channel 2: user range setting 1 (RWw9: 0031 _H) |
| | HOLD/CLEAR setting: channels 1, 2: CLEAR (RWwB: 0 _H) |
| | Initial data processing completion flag (RY18) is turned on. |
| | Initial data setting request flag (RY19) is turned on. |
| Initial data processing request flag (RX18) turns off | Initial data processing completion flag (RY18) is turned off. |
| Initial data setting completion flag (RX19) turns on | Initial data setting request flag (RY19) is turned off. |

(c) Setting results

The setting results are shown below.

| Remote device station initial setting: Procedure registration module 1: Target station 1 | | | | | | | | | |
|--|-----------------------|-----------------------|--------|---------|----------------------|---------------|------------|--|--|
| Input format: <input type="text" value="HEX"/> | | | | | | | | | |
| Execute Flag | Operational condition | Executorial condition | | | Details of execution | | | | |
| | | Condition | Device | Execute | Write Device | Device Number | Write Data | | |
| Execute | Set new | RX | 18 | ON | RWw | 08 | 00FC | | |
| Execute | Same as prev.set | RX | 18 | ON | RWw | 09 | 0031 | | |
| Execute | Same as prev.set | RX | 18 | ON | RWw | 0B | 0000 | | |
| Execute | Same as prev.set | RX | 18 | ON | RY | 18 | ON | | |
| Execute | Same as prev.set | RX | 18 | ON | RY | 19 | ON | | |
| Execute | Set new | RX | 18 | OFF | RY | 18 | OFF | | |
| Execute | Set new | RX | 19 | ON | RY | 19 | OFF | | |

POINT

- (1) If the remote device station initialization procedure registration directive (SB000D) is turned off after the initial processing, all RY signals that were turned on within the initial procedure registration turn off. Hence, turn on the "CH. □ analog output enable/disable flag (RYn0 to RYn7)" in the sequence program.
- (2) When the initial setting (analog output enable/disable setting (RWwm+8), CH. □ output range setting (RWwm+9, RWwm+A) or HOLD/CLEAR setting (RWwm+B) has been changed, the remote device station initialization procedure registration function cannot be used.
Change the initial setting in the sequence program.
- (3) For the case where the remote device station initialization procedure registration function is not used but a sequence program is used to make setting, refer to the user's manual of the used master module.

(3) Program example

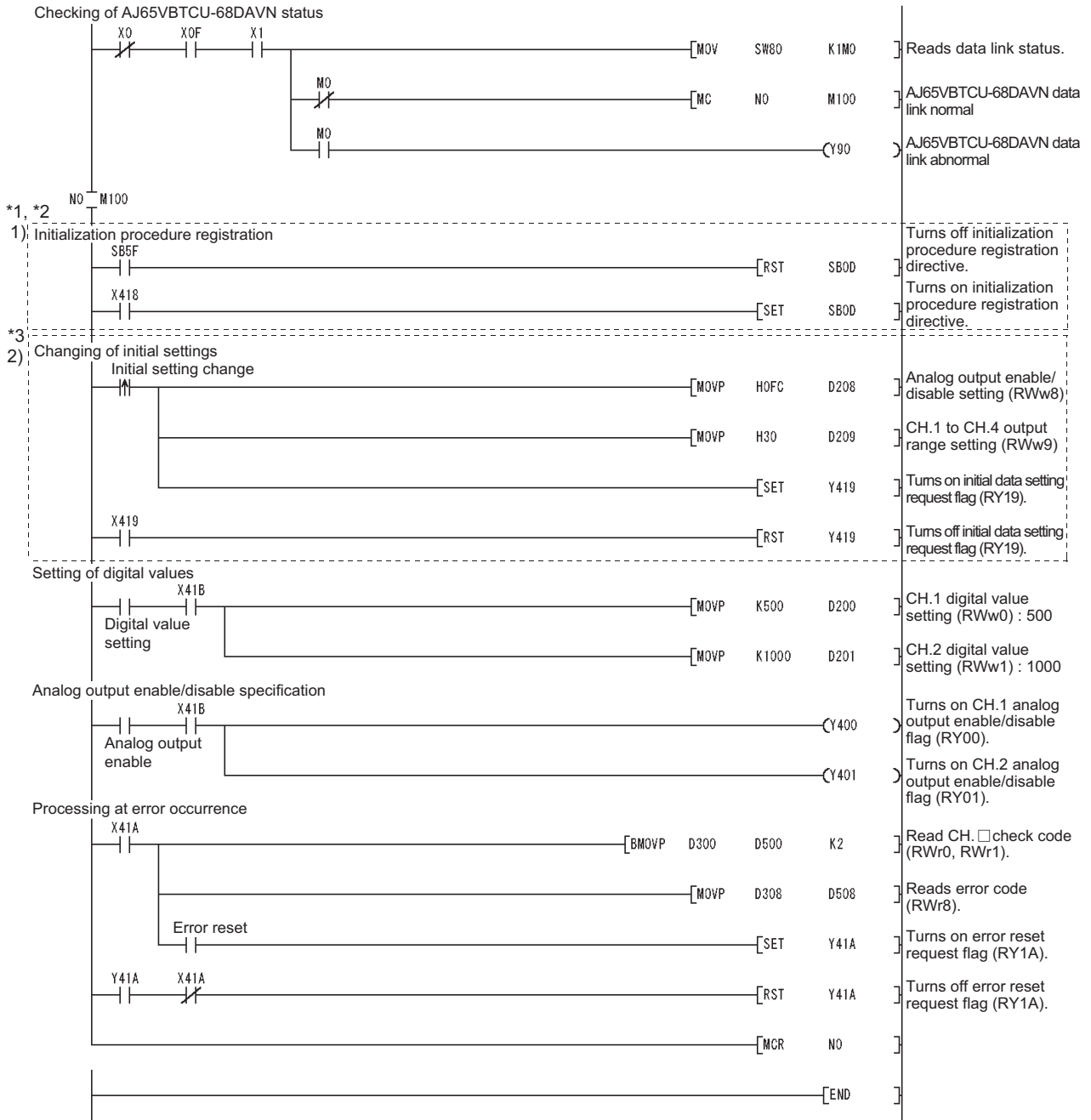

*1 When making remote device station initialization procedure registration to multiple stations, correct the program within the dotted line 1) as shown below.

[System configuration]

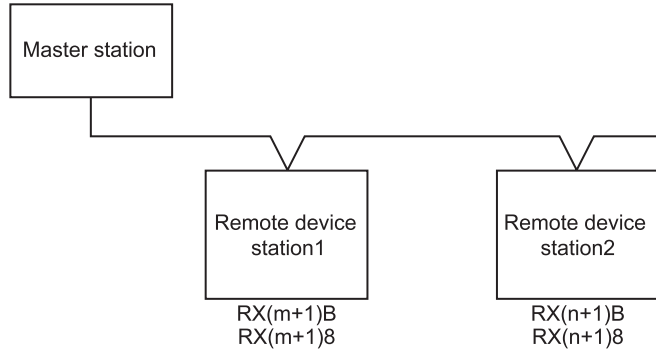

[Corrected program]

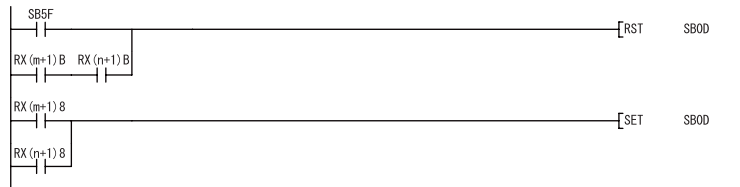

- RX(m+1)B and RX(n+1)B are remote READY.
- RX(m+1)8 and RX(n+1)8 are initial data processing request flags.

Insert the remote READY and initial data processing request flags for all the stations, to which the remote device station initialization procedure registration has been made, into the program.

[Usage in combination with other remote device stations]

- (1) Depending on the remote device stations to be used, the program enclosed by the dotted line 1) has two programming patterns as shown in the above and the below figures. (To check which pattern can be used, refer to the manual for the remote device to be used.)

[System configuration]

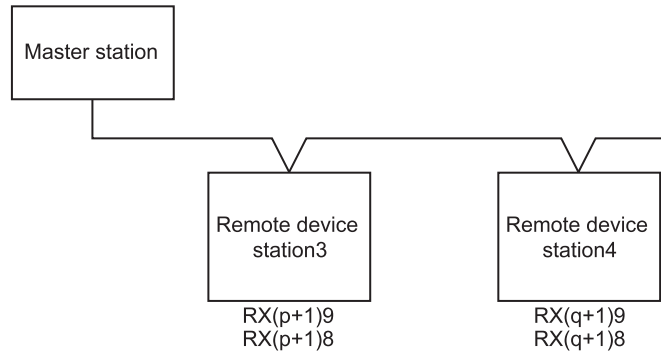

[Corrected program]

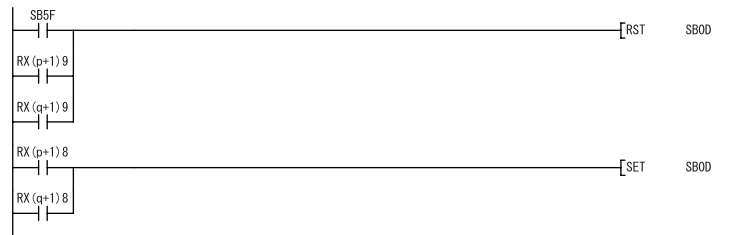

- RX(p+1)9 and RX(q+1)9 are initial data setting completion flags.
- RX(p+1)8 and RX(q+1)8 are initial data processing request flags.

- (2) When using the program enclosed by the dotted line 1) in combination with other remote device stations, correct the program as shown below.

[System configuration]

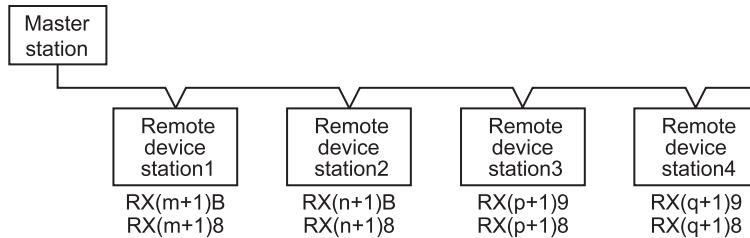

[Corrected program]

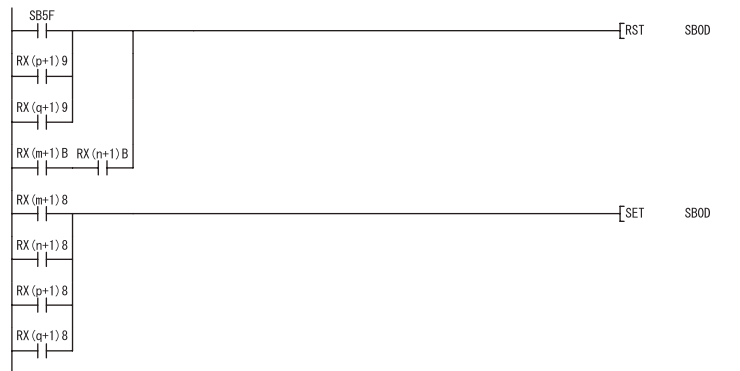

Note that the master module can register the initialization procedure of only the specified station out of the multiple remote device stations.
 The master module supporting this function is the QJ61BT11N which serial No's first 5 digits is 08032 or later.
 For details, refer to the CC-Link System Master/Local Module User's Manual.

- *2 Before the communication program is executed with remote device stations, the program enclosed by the dotted line 1) enables the initial setting by using the SB0D (remote device station initialization procedure registration instruction) and SB5F (completion status of remote device station initialization procedure). Initialization processing can't be made only by the parameter setting of GX Developer.
- *3 The program enclosed by the dotted line 2) is necessary only when the initial settings are changed.

5.2.3 Program Example for Use of the QnACPU

GX Developer is used to set the network and automatic refresh parameters.

- (1) Parameter setting
 - (a) Network parameter setting

| | |
|--------------------------------------|---------------------|
| Start I/O No. | 1 |
| Type | Master station |
| All connect count | 1 |
| Remote input(RX) | |
| Remote output(RY) | |
| Remote register(RW/r) | |
| Remote register(RW/w) | |
| Special relay(SB) | |
| Special register(SW) | |
| Retry count | 3 |
| Automatic reconnection station count | 1 |
| Wait master station No. | 0 |
| PLC down select | Stop |
| Scan mode setting | Asynchronously |
| Delay information setting | 0 |
| Station information setting | Station information |

| StationNo. | Station type | Exclusive station count | Reserve/invalid station select | Intelligent buffer select(word) | | |
|------------|-----------------------|-------------------------|--------------------------------|---------------------------------|---------|-----------|
| | | | | Send | Receive | Automatic |
| 1/1 | Remote device station | Exclusive station 3 | No setting | | | |

- (b) Automatic refresh parameter setting

| | |
|--------------------------------------|---------------------|
| Start I/O No. | 1 |
| Type | Master station |
| All connect count | 1 |
| Remote input(RX) | X400 |
| Remote output(RY) | Y400 |
| Remote register(RW/r) | D300 |
| Remote register(RW/w) | D200 |
| Special relay(SB) | B0 |
| Special register(SW) | w0 |
| Retry count | 3 |
| Automatic reconnection station count | 1 |
| Wait master station No. | 0 |
| PLC down select | Stop |
| Scan mode setting | Asynchronously |
| Delay information setting | 0 |
| Station information setting | Station information |

POINT

When the QnACPU is used, using "Y" as the remote output (RY) refresh device of the automatic refresh parameter may not hold the analog value even for the HOLD setting.

For the HOLD setting, use "M" or "B" as the remote output (RY) refresh device.

(2) Program example

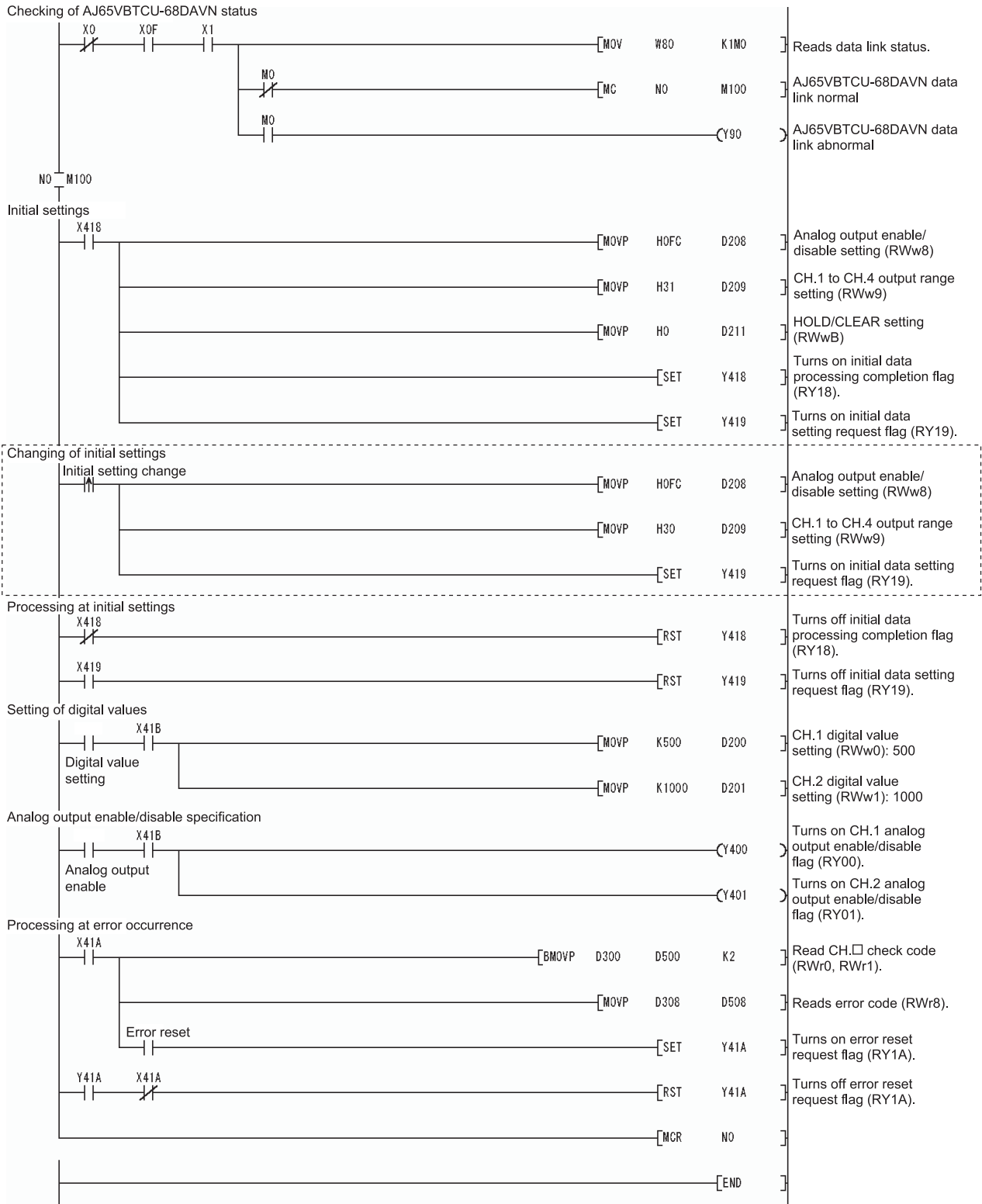

* The program enclosed by the dotted line is necessary only when the initial settings are changed.

5.2.4 Program Example for Use of the ACPU/QCPU (A mode) (dedicated instructions)

A sequence program is used to set the network and automatic refresh parameters.

(1) Program example

Setting of network parameters using RLPA dedicated instruction

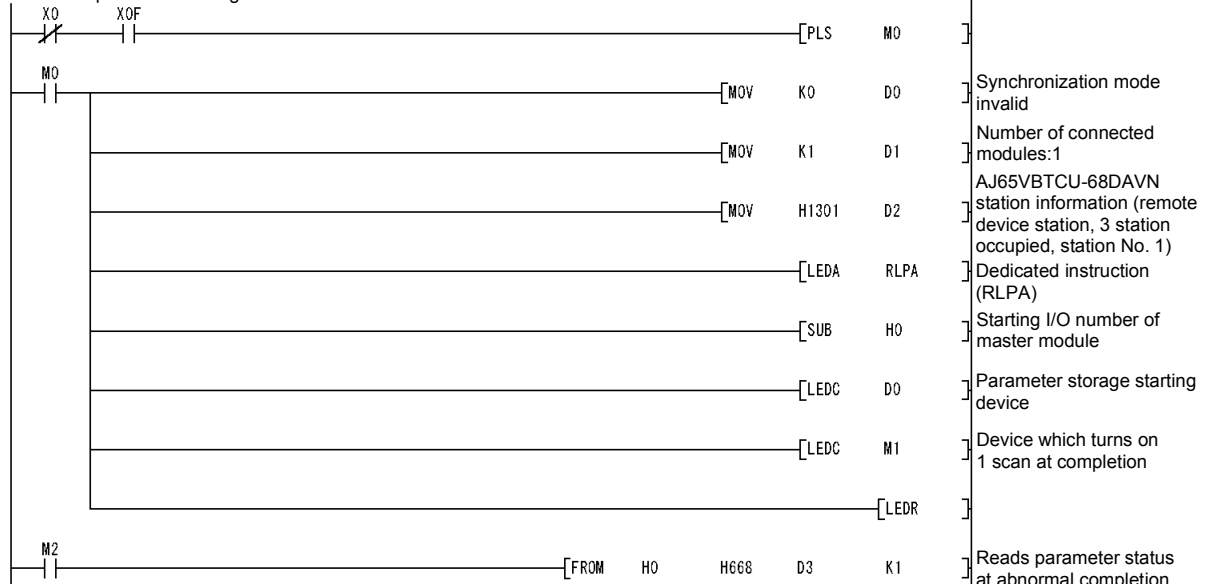

Setting of automatic refresh parameters using RRPA dedicated instruction

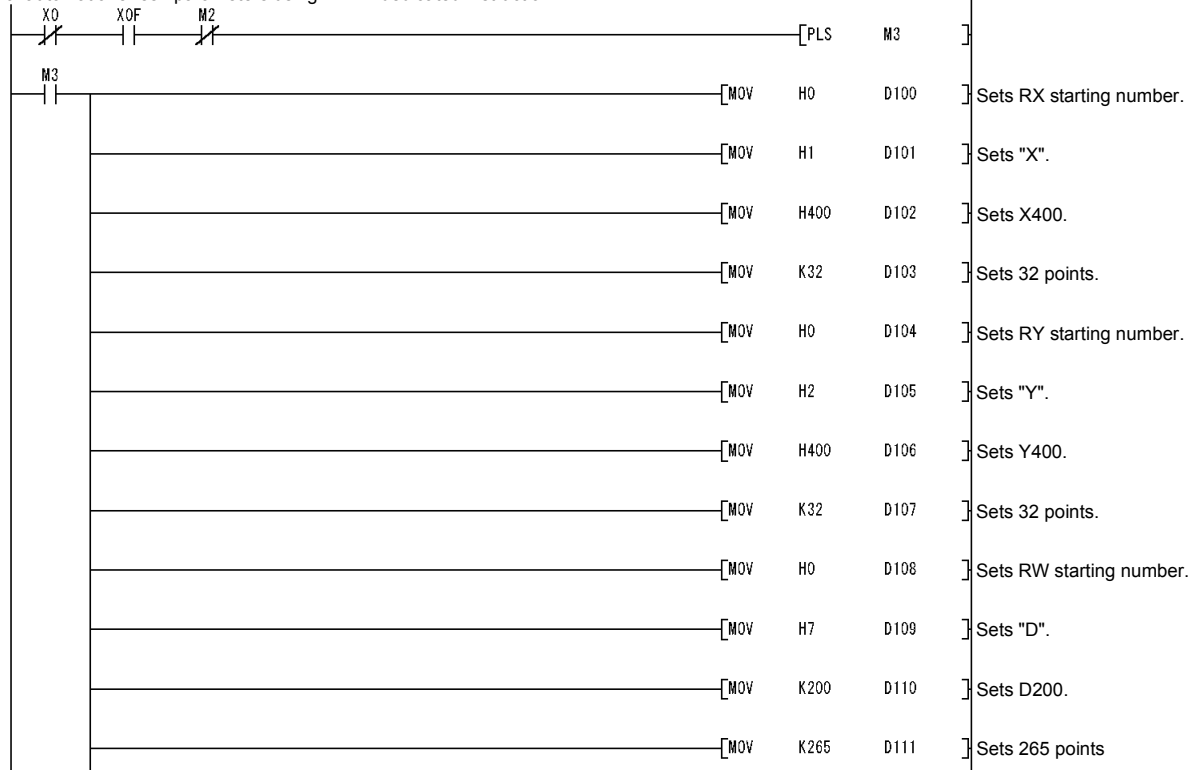

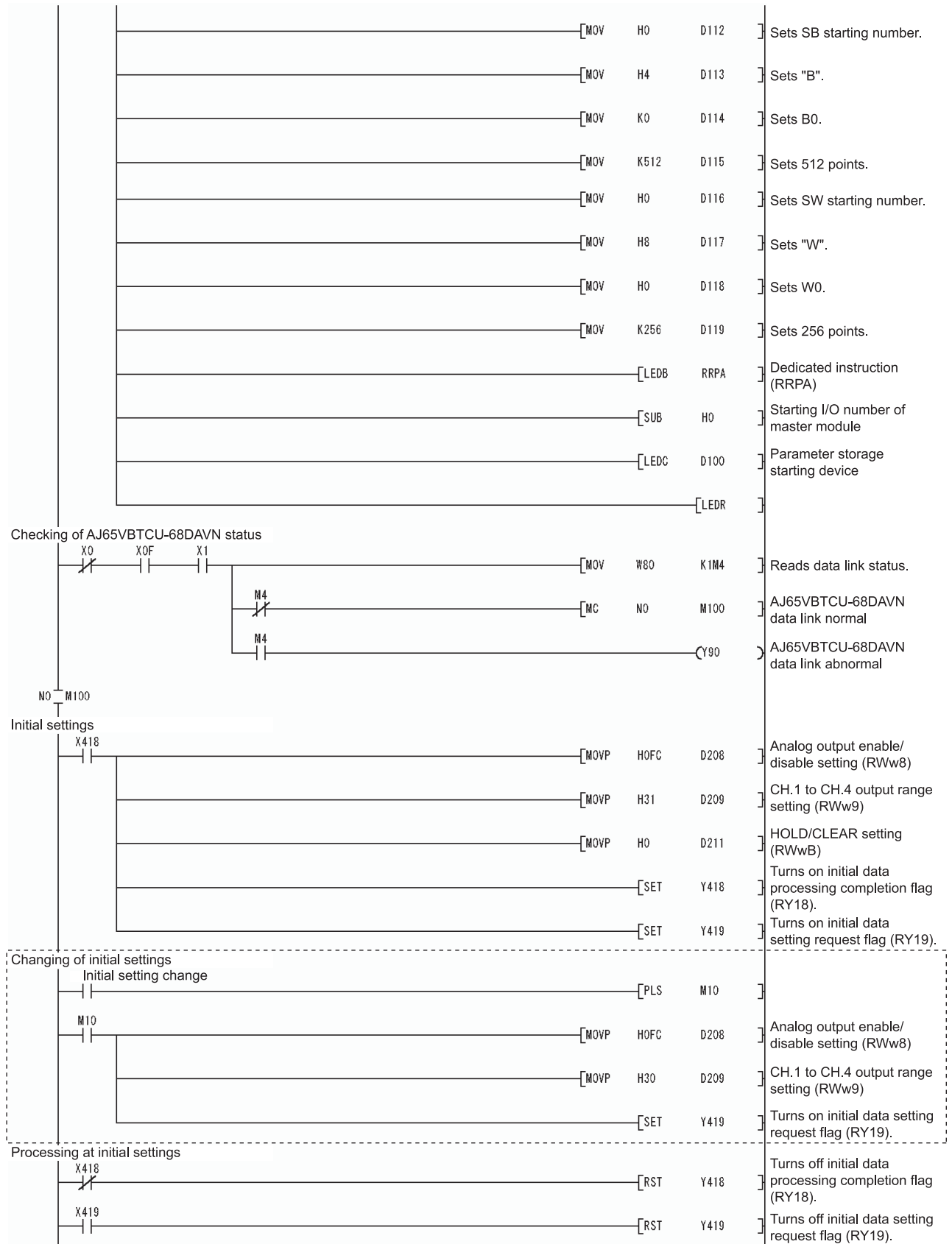

* The program enclosed by the dotted line is necessary only when the initial settings are changed.

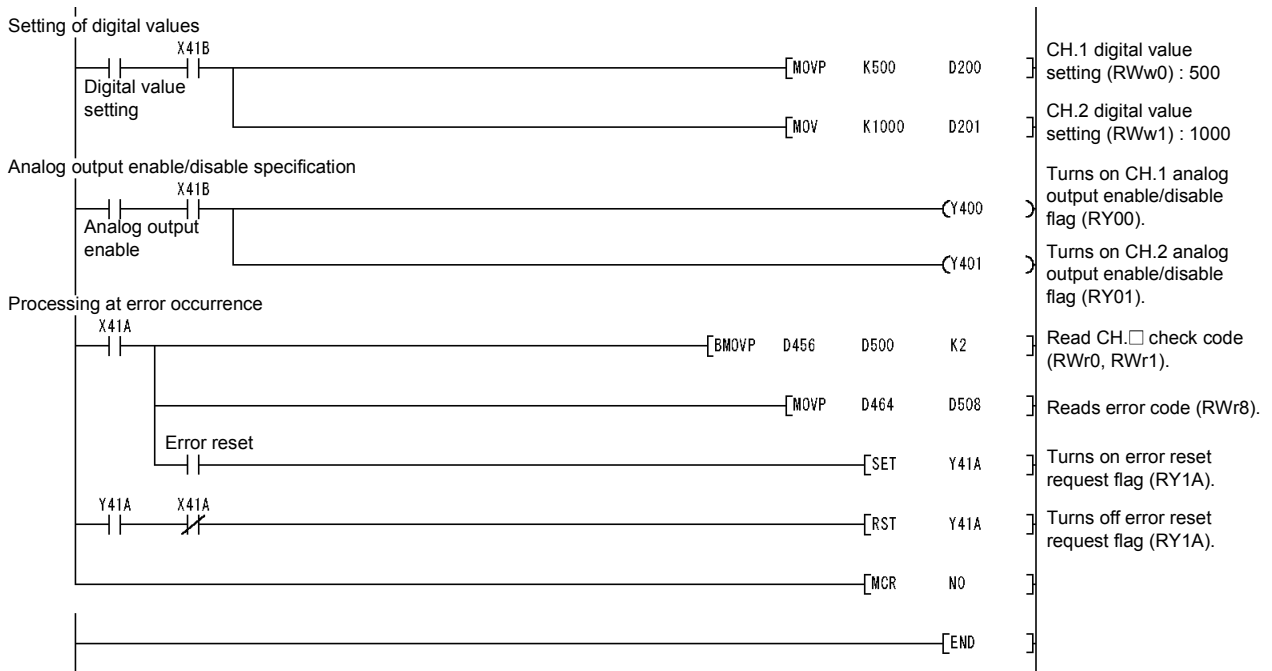

5.2.5 Program Example for Use of the ACPUCPU/QCPU (A mode) (FROM/TO instructions)

A sequence program is used to set the network parameters.

(1) Program example

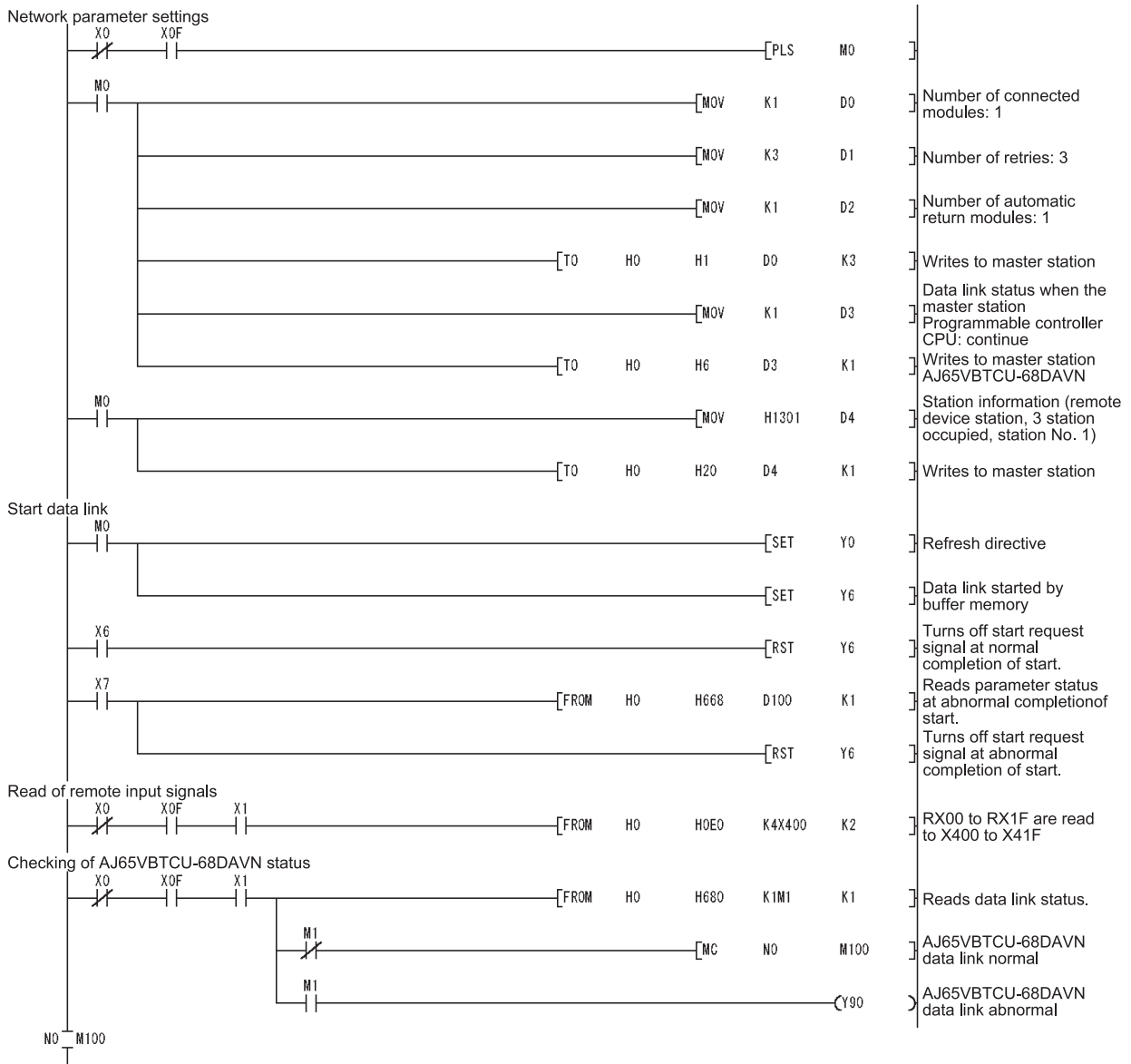

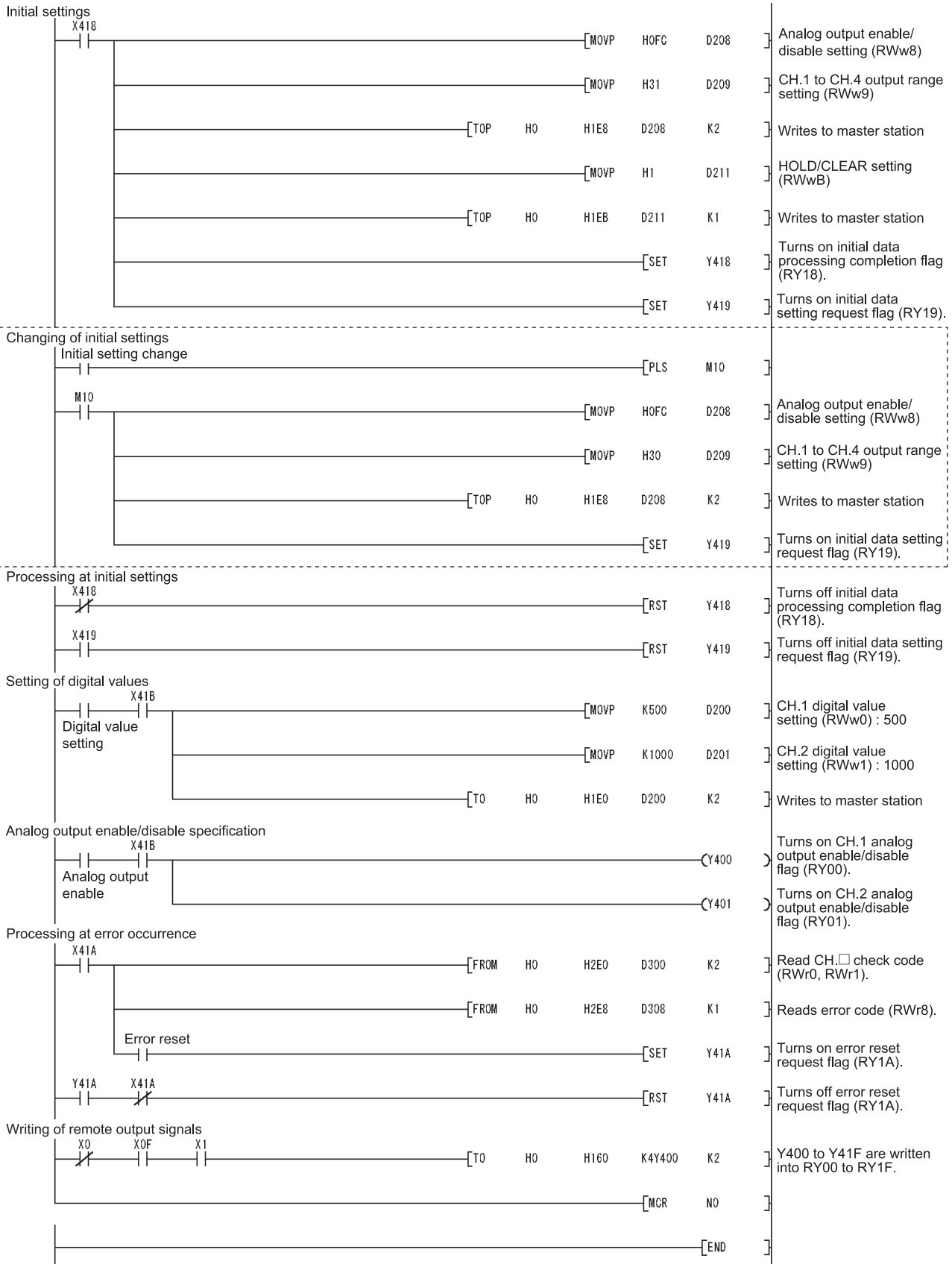

* The program enclosed by the dotted line is necessary only when the initial settings are changed.

5.3 When Remote Net Ver. 2 Mode Is Used

5.3.1 Conditions of program examples

The program examples in this section are created under the following conditions.

(1) System configuration

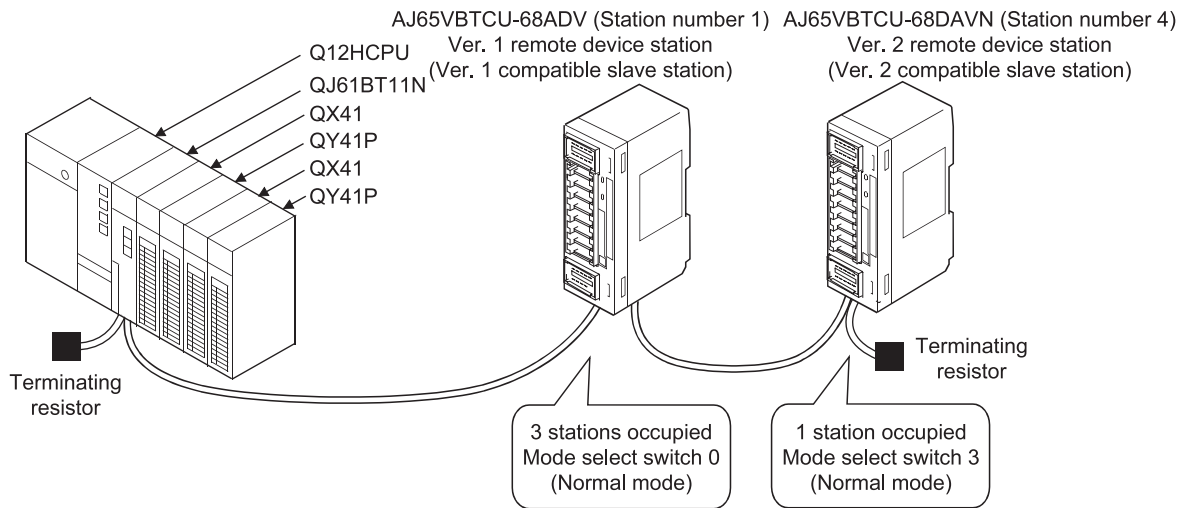

(2) Relationships between programmable controller CPU, AJ65VBTCU-68ADV and AJ65VBTCU-68DAVN

[Remote input (RX), remote output (RY)]

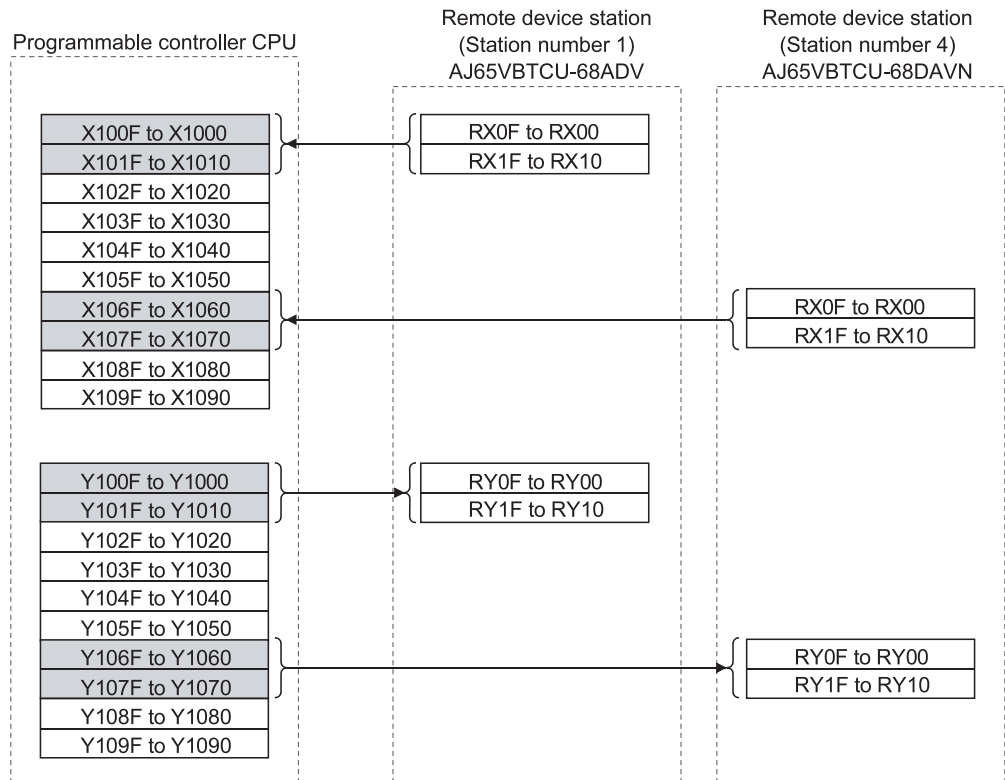

[Remote registers (RWw, RWr)]

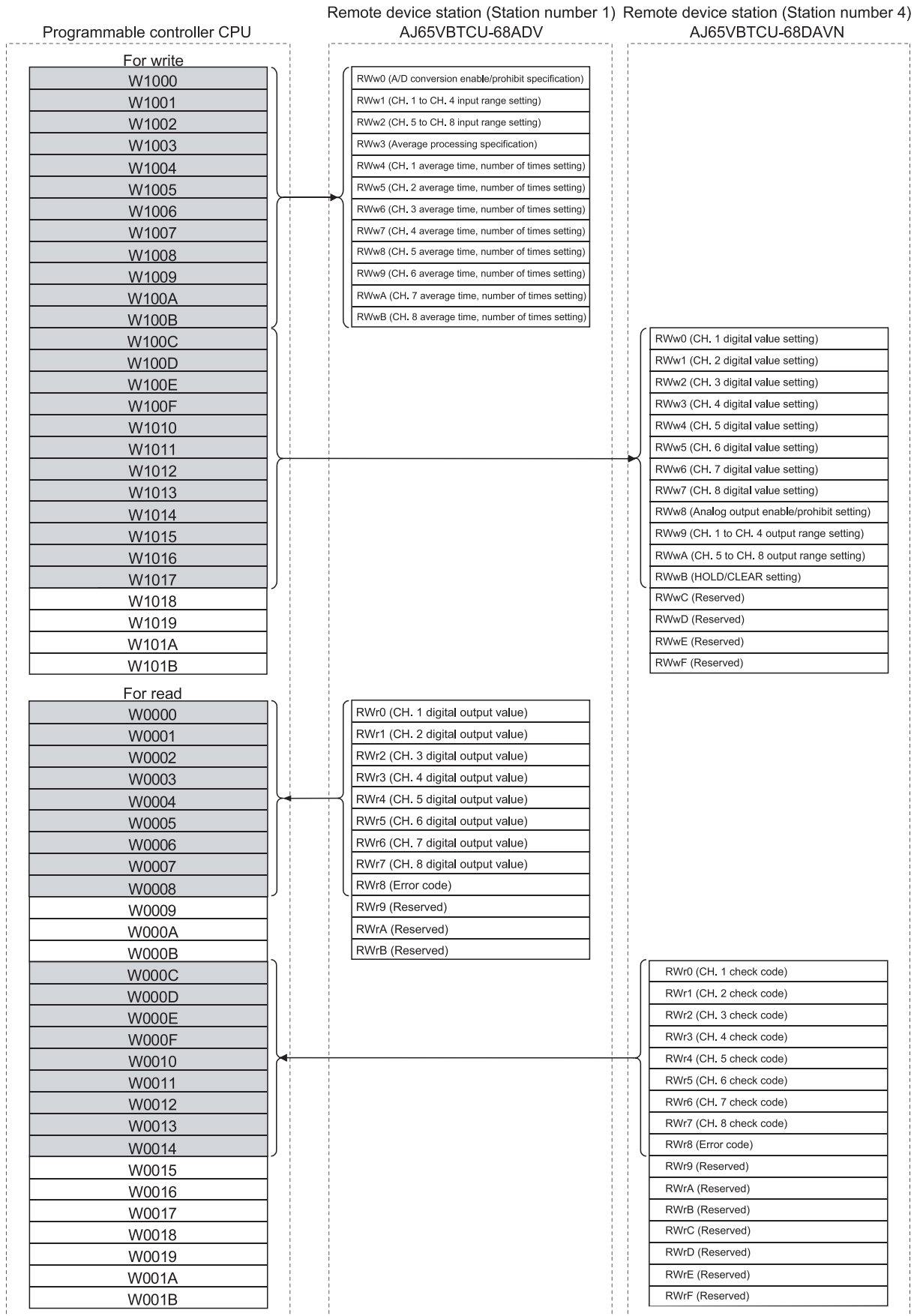

(3) Initial settings

| Remote Device Station | Setting Item | Settings |
|-----------------------|---|--|
| AJ65VBTCU-68ADV | A/D conversion enable/prohibit specification (RWw0) | A/D conversion enable channel: Channel 1, 2 |
| | CH. 1 to CH. 4 input range setting (RWw1) | Channel 1: 0 to 5V Channel 2: User range setting 1 |
| | Average processing specification (RWw3) | Channel 1: Sampling processing Channel 2: Average processing, number of times averaging |
| | CH. 2 average time, number of times setting (RWw5) | Number of average processing times of channel 2: 16 times |
| AJ65VBTCU-68DAVN | Analog output enable/disable setting (RWw8) | Channels 1, 2: enable |
| | CH. 1 to CH. 4 output range setting (RWw9) | Channel 1: 0 to 5V Channel 2: user range setting 1 |
| | HOLD/CLEAR setting (RWwB) | Channels 1, 2: CLEAR |

(4) Other settings

| Remote Device Station | Setting Item | Settings |
|-----------------------|---|----------|
| AJ65VBTCU-68DAVN | CH. 1 digital value (RWw0) | 500 |
| | CH. 2 digital value (RWw1) | 1000 |
| | CH. 1 analog output enable/prohibit flag (RY00) | Enable |
| | CH. 2 analog output enable/prohibit flag (RY01) | Enable |

POINT

When using the AJ65VBTCU-68DAVN as the ver. 2 remote device station in the normal mode, set the mode select switch to "3".

5.3.2 Setting of parameters and initialization procedure registration

The network parameters and automatic refresh parameters are set using GX Developer.

Use of the remote device station initialization procedure registration function makes initial setting easy.

(1) Parameter setting

(a) Network parameter setting

| | |
|---------------------------------------|--------------------------|
| 1 | |
| Start I/O No | 0000 |
| Operational setting | Operational settings |
| Type | Master station |
| Master station data link type | PLC parameter auto start |
| Mode | Remote net(Ver.2 mode) |
| All connect count | 2 |
| Remote input(RX) | |
| Remote output(RY) | |
| Remote register(RW/r) | |
| Remote register(RW/w) | |
| Ver.2 Remote input(RX) | |
| Ver.2 Remote output(RY) | |
| Ver.2 Remote register(RW/r) | |
| Ver.2 Remote register(RW/w) | |
| Special relay(SB) | |
| Special register(SW) | |
| Retry count | 3 |
| Automatic reconnection station count | 1 |
| Stand by master station No. | |
| PLC down select | Stop |
| Scan mode setting | Asynchronous |
| Delay information setting | 0 |
| Station information setting | Station information |
| Remote device station initial setting | Initial settings |
| Interrupt setting | Interrupt settings |

| Station No. | Station type | Expanded cyclic setting | Exclusive station count | Remote station points | Reserve/invalid station select | Intelligent buffer select(word) |
|-------------|-----------------------------|-------------------------|-------------------------|-----------------------|--------------------------------|---------------------------------|
| 1/1 | Ver.1 Remote device station | single | Exclusive station 3 | 96 points | No setting | Send Receive Automatic |
| 2/4 | Ver.2 Remote device station | quadruple | Exclusive station 1 | 64 points | No setting | |

(b) Automatic refresh parameter setting

| | |
|---------------------------------------|--------------------------|
| 1 | |
| Start I/O No | 0000 |
| Operational setting | Operational settings |
| Type | Master station |
| Master station data link type | PLC parameter auto start |
| Mode | Remote net(Ver.2 mode) |
| All connect count | 2 |
| Remote input(RX) | X1000 |
| Remote output(RY) | Y1000 |
| Remote register(RW/r) | w0 |
| Remote register(RW/w) | w1000 |
| Ver.2 Remote input(RX) | |
| Ver.2 Remote output(RY) | |
| Ver.2 Remote register(RW/r) | |
| Ver.2 Remote register(RW/w) | |
| Special relay(SB) | SB0 |
| Special register(SW) | SW0 |
| Retry count | 3 |
| Automatic reconnection station count | 1 |
| Stand by master station No. | |
| PLC down select | Stop |
| Scan mode setting | Asynchronous |
| Delay information setting | 0 |
| Station information setting | Station information |
| Remote device station initial setting | Initial settings |
| Interrupt setting | Interrupt settings |

POINT

When setting X, Y, B, W, SD and SW as refresh devices, make setting so that their device numbers do not overlap the device numbers used on the other networks, etc.

(2) Initial setting by remote device station initialization procedure registration function

(a) Setting of target station numbers

Set the station numbers to which initial setting will be made.

Set the target station numbers to "1" and "4".

| | Target station No. | No. of registered procedures | | Target station No. | No. of registered procedures | |
|---|--------------------|------------------------------|------------------|--------------------|------------------------------|------------------|
| 1 | 1 | 0 | Regist procedure | 9 | | Regist procedure |
| 2 | 4 | 0 | Regist procedure | 10 | | Regist procedure |
| 3 | | | Regist procedure | 11 | | Regist procedure |

(b) Selection of procedure registration (part 1)

Make setting for the AJ65VBTCU-68ADV.

Click Procedure registration of target station number "1".

(c) Setting of procedure registration (part 1)

Set the conditions and execution for the AJ65VBTCU-68ADV.

When the initial data processing request flag (RX18) turns ON and Remote device station initialization procedure registration (SB0D) is set, the following data are registered to the AJ65VBTCU-68ADV.

| Procedure Execution Condition in AJ65VBTCU-68ADV | Execution Data |
|---|---|
| Initial data processing request flag (RX18) turns ON | A/D conversion enable/prohibit specification: Channel 1, 2: Enable (RWw0: 0003 _H) |
| | CH. 1 to CH. 4 input range setting : Channel 1: 0 to 5V : Channel 2: User range setting 1 (RWw1: 31 _H) |
| | Average processing specification : Channel 1: Sampling processing : Channel 2: Average processing, number of times averaging (RWw3: 200 _H) |
| | CH. 2 average time, number of times setting: Channel 2: 16 times (RWw5: 10 _H) |
| | Initial data processing completion flag (RY18) is turned ON. Initial data setting request flag (RY19) is turned ON. |
| Initial data processing request flag (RX18) turns OFF | Initial data processing completion flag (RY18) is turned OFF. |
| Initial data setting completion flag (RX19) turns ON | Initial data setting request flag (RY19) is turned OFF. |

(d) Setting result (part 1)

The following indicates the setting result of the AJ65VBTCU-68ADV.

Remote device station initial setting: Procedure registration module 1: Target station 1

Input format:

| Execute Flag | Operational condition | Executorial condition | | | Details of execution | | |
|--------------|-----------------------|-----------------------|---------------|-------------------|----------------------|---------------|------------|
| | | Condition Device | Device Number | Execute Condition | Write Device | Device Number | Write Data |
| Execute | Set new | RX | 18 | ON | RWw | 00 | 0003 |
| Execute | Same as prev.set | RX | 18 | ON | RWw | 01 | 0031 |
| Execute | Same as prev.set | RX | 18 | ON | RWw | 03 | 0200 |
| Execute | Same as prev.set | RX | 18 | ON | RWw | 05 | 0010 |
| Execute | Same as prev.set | RX | 18 | ON | RY | 18 | ON |
| Execute | Same as prev.set | RX | 18 | ON | RY | 19 | ON |
| Execute | Set new | RX | 18 | OFF | RY | 18 | OFF |
| Execute | Set new | RX | 19 | ON | RY | 19 | OFF |

- (e) Selection of procedure registration (part 2)
Make setting for the AJ65VBTCU-68DAVN.
Click Procedure registration of target station number "4".

- (f) Setting of procedure registration (part 2)
Set the conditions and execution for the AJ65VBTCU-68DAVN.

When the initial data processing request flag (RX18) turns ON and Remote device station initialization procedure registration (SB0D) is set, the following data are registered to the AJ65VBTCU-68DAVN.

| Procedure Execution Condition in AJ65VBTCU-68DAVN | Execution Data |
|---|--|
| Initial data processing request flag (RX18) turns ON | Analog output enable/prohibit setting: Channel 1, 2: Enable (RWw8: 00FC _H) |
| | CH. 1 to CH. 4 input range setting : Channel 1: 0 to 5V : Channel 2: User range setting 1 (RWw9: 0031 _H) |
| | HOLD/CLEAR setting: Channel 1, 2: CLEAR (RWwB: 0 _H) |
| | Initial data processing completion flag (RY18) is turned ON. Initial data setting request flag (RY19) is turned ON. |
| Initial data processing request flag (RX18) turns OFF | Initial data processing completion flag (RY18) is turned OFF. |
| Initial data setting completion flag (RX19) turns ON | Initial data setting request flag (RY19) is turned OFF. |

- (g) Setting result (part 2)
The following indicates the setting result of the AJ65VBTCU-68DAVN.

Remote device station initial setting: Procedure registration module 1: Target station 4

Input format:

| Execute Flag | Operational condition | Executorial condition | | | Details of execution | | |
|--------------|-----------------------|-----------------------|---------------|-------------------|----------------------|---------------|------------|
| | | Condition Device | Device Number | Execute Condition | Write Device | Device Number | Write Data |
| Execute | Set new | RX | 18 | ON | RWw | 08 | 00FC |
| Execute | Same as prev.set | RX | 18 | ON | RWw | 09 | 0031 |
| Execute | Same as prev.set | RX | 18 | ON | RWw | 0B | 0000 |
| Execute | Same as prev.set | RX | 18 | ON | RY | 18 | ON |
| Execute | Same as prev.set | RX | 18 | ON | RY | 19 | ON |
| Execute | Set new | RX | 18 | OFF | RY | 18 | OFF |
| Execute | Set new | RX | 19 | ON | RY | 19 | OFF |

| |
|---|
| POINT |
| <p>(1) If the remote device station initialization procedure registration command (SB000D) is turned OFF after initial processing, all RY signals that turned ON in the initial procedure registration turn OFF. Hence, turn ON "CH. □ analog output enable/prohibit flag (RYn0 to RYn7)" in the sequence program.</p> <p>(2) When the initial setting (analog output enable/prohibit setting (RWwn+8), CH. □ output range setting (RWwn+9, RWwn+A), HOLD/CLEAR setting (RWw+B)), the remote device station initialization procedure registration function cannot be used. Change the initial setting in the sequence program.</p> <p>(3) When the remote device station initialization procedure registration function is not used but a sequence program is used to make setting, refer to the user's manual of the used master module.</p> |

5.3.3 Program example

Confirmation of AJ65VBTCU-68ADV, AJ65VBTCU-68DAVN status

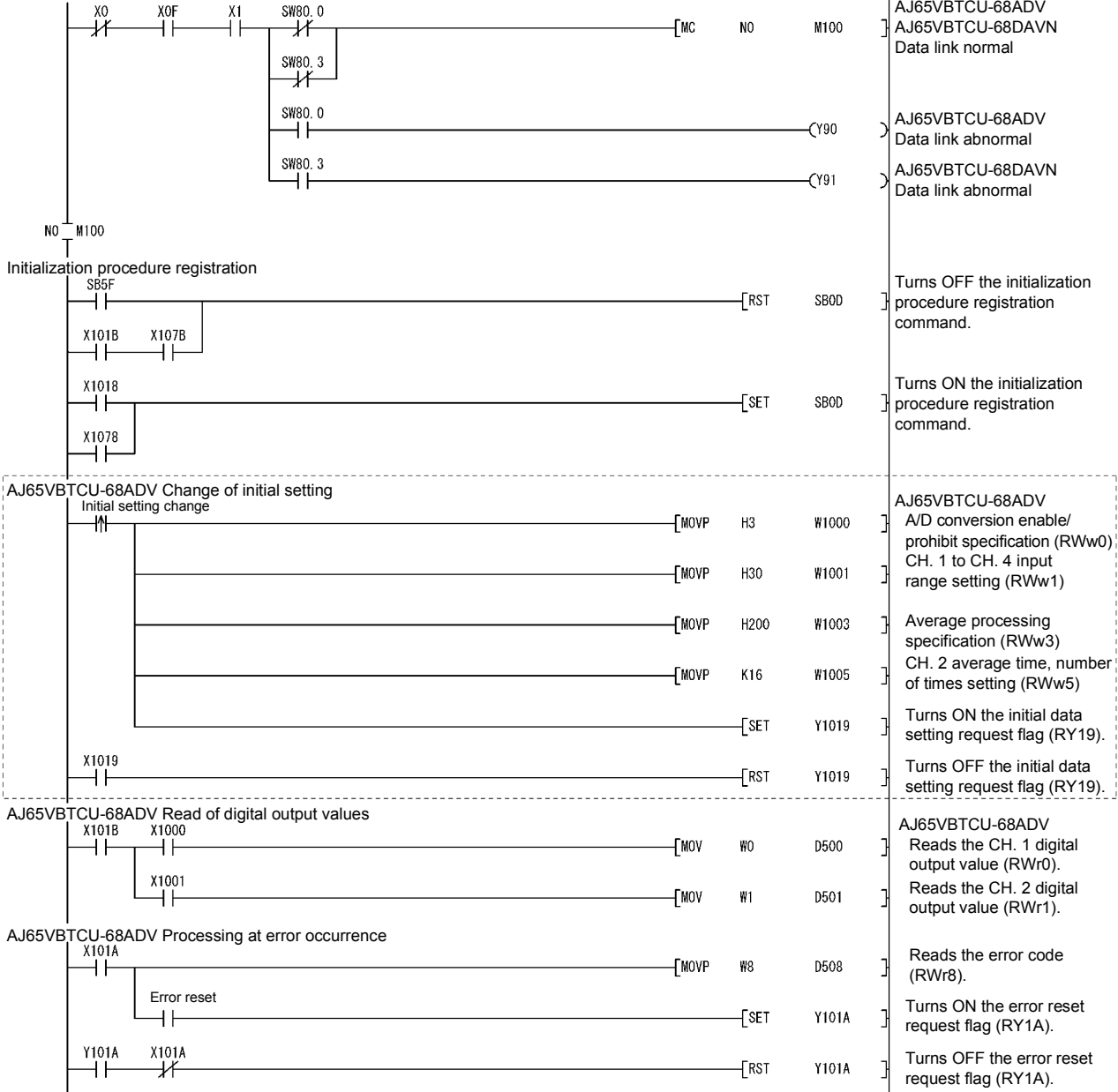

* The program part enclosed by the dotted line is required only when the initial setting is changed.

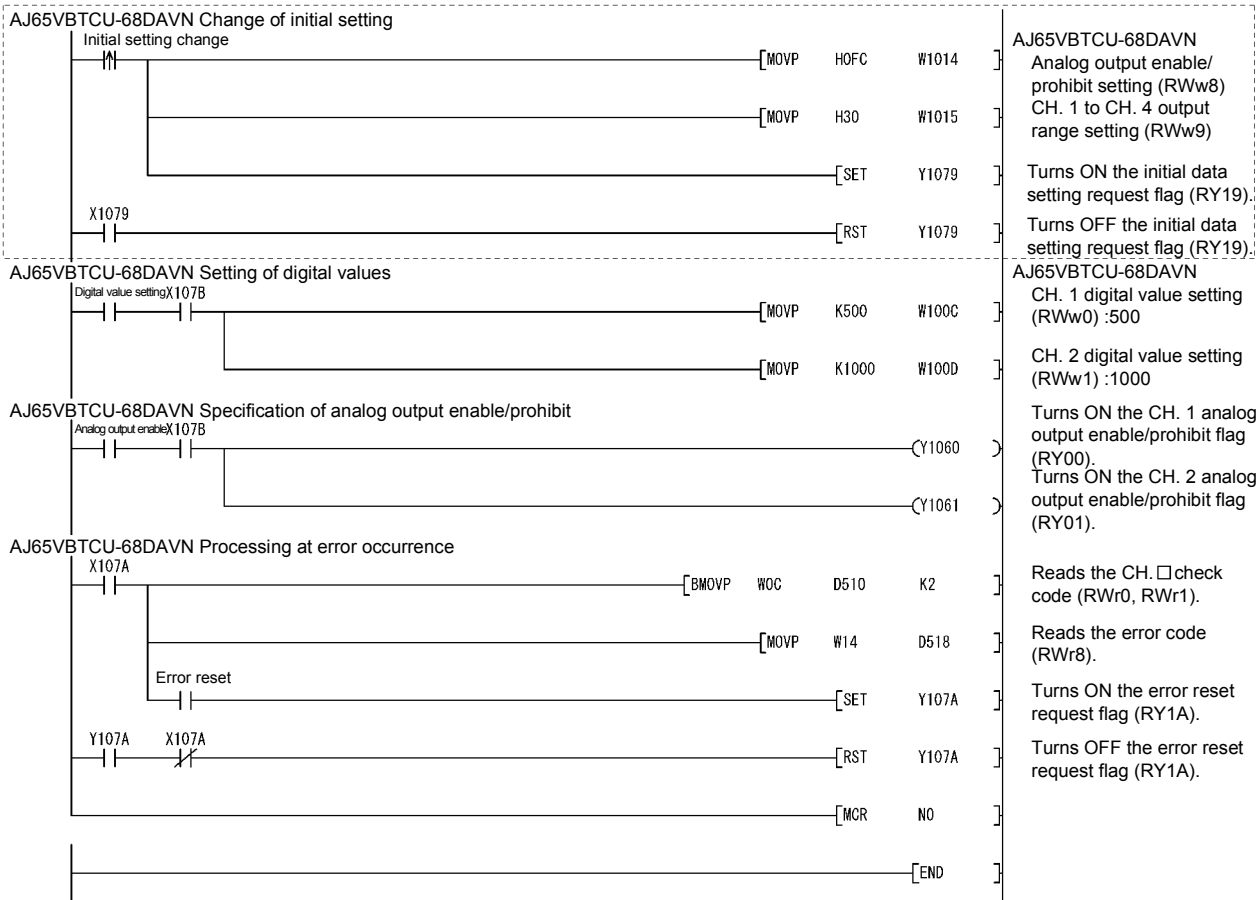

* The program part enclosed by the dotted line is required only when the initial setting is changed.

5.4 When Remote Net Additional Mode Is Used

5.4.1 Conditions of program examples

The program examples in this section are created under the following conditions.

(1) System configuration

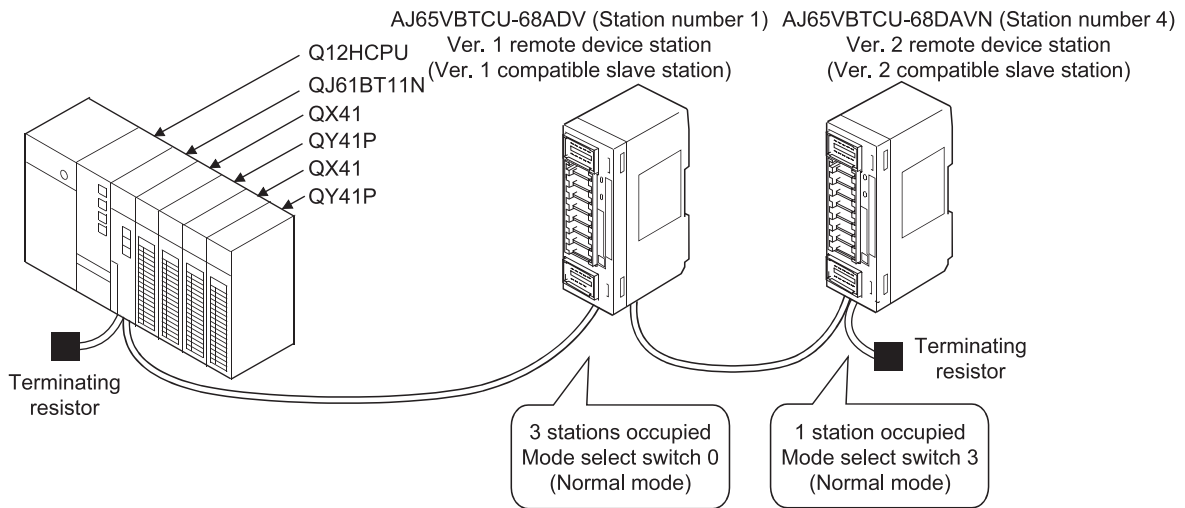

(2) Relationships between programmable controller CPU, AJ65VBTCU-68ADV and AJ65VBTCU-68DAVN

[Remote input (RX), remote output (RY)]

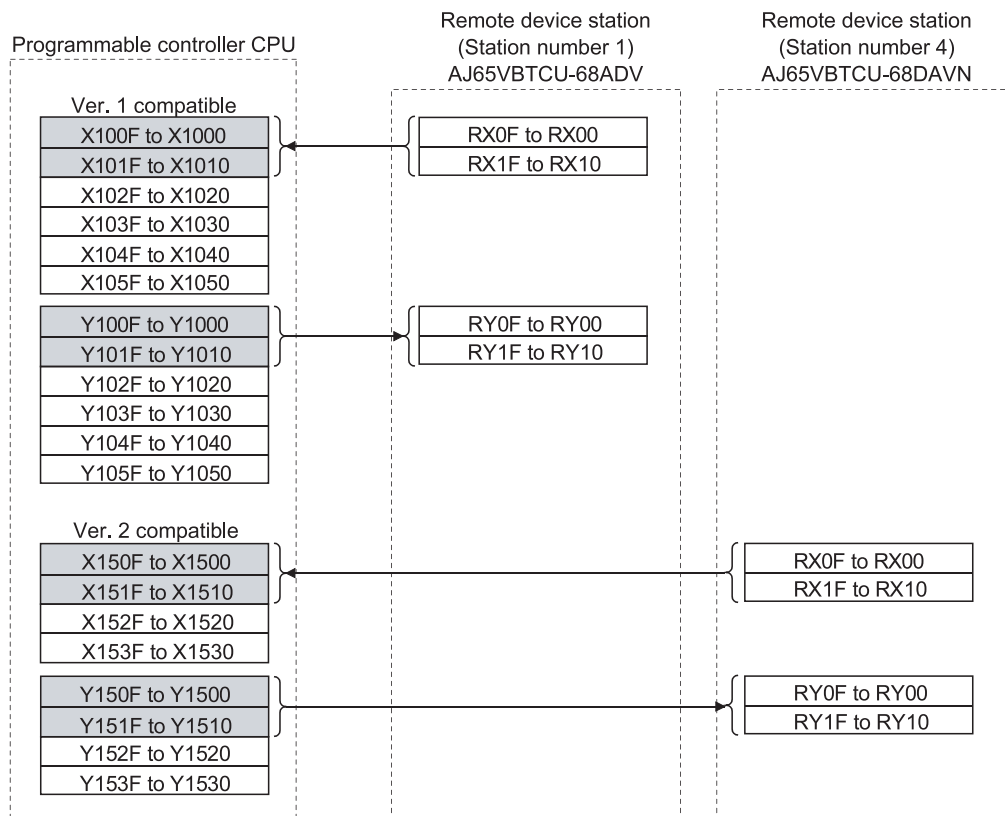

[Remote registers (RWw, RWr)]

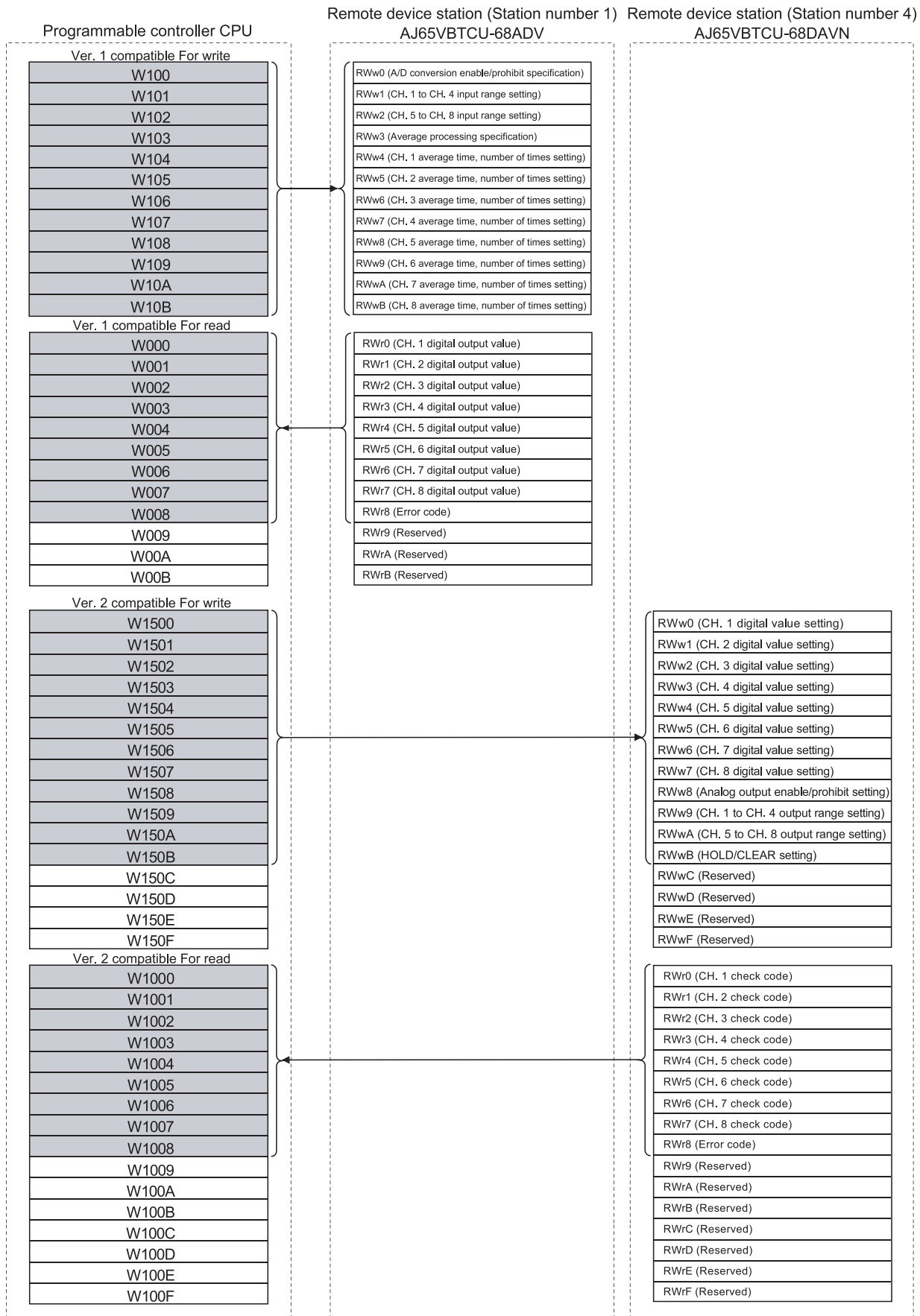

(3) Initial settings

| Remote Device Station | Setting Item | Settings |
|-----------------------|---|--|
| AJ65VBTCU-68ADV | A/D conversion enable/prohibit specification (RWw0) | A/D conversion enable channel: Channel 1, 2 |
| | CH. 1 to CH. 4 input range setting (RWw1) | Channel 1: 0 to 5V Channel 2: User range setting 1 |
| | Average processing specification (RWw3) | Channel 1: Sampling processing Channel 2: Average processing, number of times averaging |
| | CH. 2 average time, number of times setting (RWw5) | Number of average processing times of channel 2: 16 times |
| AJ65VBTCU-68DAVN | Analog output enable/prohibit setting (RWw8) | Channel 1, 2: Enable |
| | CH. 1 to CH. 4 output range setting (RWw9) | Channel 1: 0 to 5V Channel 2: User range setting 1 |
| | HOLD/CLEAR setting (RWwB) | Channel 1, 2: CLEAR |

(4) Other settings

| Remote Device Station | Setting Item | Settings |
|-----------------------|---|----------|
| AJ65VBTCU-68DAVN | CH. 1 digital value (RWw0) | 500 |
| | CH. 2 digital value (RWw1) | 1000 |
| | CH. 1 analog output enable/prohibit flag (RY00) | Enable |
| | CH. 2 analog output enable/prohibit flag (RY01) | Enable |

POINT

When using the AJ65VBTCU-68DAVN as the ver. 2 remote device station in the normal mode, set the mode select switch to "3".

5.4.2 Setting of parameters and initialization procedure registration

The network parameters and automatic refresh parameters are set using GX Developer.

Use of the remote device station initialization procedure registration function makes initial setting easy.

(1) Parameter setting

(a) Network parameter setting

| | |
|---------------------------------------|-----------------------------|
| 1 | |
| Start I/O No | 0000 |
| Operational setting | Operational settings |
| Type | Master station |
| Master station data link type | PLC parameter auto start |
| Mode | Remote net(Additional mode) |
| All connect count | 2 |
| Remote input(RX) | |
| Remote output(RY) | |
| Remote register(RW/r) | |
| Remote register(RW/w) | |
| Ver.2 Remote input(RX) | |
| Ver.2 Remote output(RY) | |
| Ver.2 Remote register(RW/r) | |
| Ver.2 Remote register(RW/w) | |
| Special relay(SB) | |
| Special register(SW) | |
| Retry count | 3 |
| Automatic reconnection station count | 1 |
| Stand by master station No. | |
| PLC down select | Stop |
| Scan mode setting | Asynchronous |
| Delay information setting | 0 |
| Station information setting | Station information |
| Remote device station initial setting | Initial settings |
| Interrupt setting | Interrupt settings |

| Station No. | Station type | Expanded cyclic setting | Exclusive station count | Remote station points | Reserve/invalid station select | Intelligent buffer select(word) | | |
|-------------|-----------------------------|-------------------------|-------------------------|-----------------------|--------------------------------|---------------------------------|---------|-----------|
| | | | | | | Send | Receive | Automatic |
| 1/1 | Ver.1 Remote device station | single | Exclusive station 3 | 96 points | No setting | | | |
| 2/4 | Ver.2 Remote device station | quadruple | Exclusive station 1 | 64 points | No setting | | | |

(b) Automatic refresh parameter setting

| | |
|---------------------------------------|-----------------------------|
| 1 | |
| Start I/O No | 0000 |
| Operational setting | Operational settings |
| Type | Master station |
| Master station data link type | PLC parameter auto start |
| Mode | Remote net(Additional mode) |
| All connect count | 2 |
| Remote input(RX) | X1000 |
| Remote output(RY) | Y1000 |
| Remote register(RW/r) | w0 |
| Remote register(RW/w) | w100 |
| Ver.2 Remote input(RX) | X1500 |
| Ver.2 Remote output(RY) | Y1500 |
| Ver.2 Remote register(RW/r) | w1000 |
| Ver.2 Remote register(RW/w) | w1500 |
| Special relay(SB) | SB0 |
| Special register(SW) | SW0 |
| Retry count | 3 |
| Automatic reconnection station count | 1 |
| Stand by master station No. | |
| PLC down select | Stop |
| Scan mode setting | Asynchronous |
| Delay information setting | 0 |
| Station information setting | Station information |
| Remote device station initial setting | Initial settings |
| Interrupt setting | Interrupt settings |

POINT

When setting X, Y, B, W, SD and SW as refresh devices, make setting so that their device numbers do not overlap the device numbers used on the other networks, etc.

(2) Initial setting by remote device station initialization procedure registration function

(a) Setting of target station numbers

Set the station numbers to which initial setting will be made.

Set the target station numbers to "1" and "4".

| | Target station No. | No. of registered procedures | | Target station No. | No. of registered procedures | |
|---|--------------------|------------------------------|------------------|--------------------|------------------------------|------------------|
| 1 | 1 | 0 | Regist procedure | 9 | | Regist procedure |
| 2 | 4 | 0 | Regist procedure | 10 | | Regist procedure |
| 3 | | | Regist procedure | 11 | | Regist procedure |

(b) Selection of procedure registration (part 1)

Make setting for the AJ65VBTCU-68ADV.

Click Procedure registration of target station number "1".

(c) Setting of procedure registration (part 1)

Set the conditions and execution for the AJ65VBTCU-68ADV.

When the initial data processing request flag (RX18) turns ON and Remote device station initialization procedure registration (SB0D) is set, the following data are registered to the AJ65VBTCU-68ADV.

| Procedure Execution Condition in AJ65VBTCU-68ADV | Execution Data |
|---|---|
| Initial data processing request flag (RX18) turns ON | A/D conversion enable/prohibit specification: Channel 1, 2: Enable (RWw0: 0003 _H) |
| | CH. 1 to CH. 4 input range setting: Channel 1: 0 to 5V : Channel 2: User range setting 1 (RWw1: 31 _H) |
| | Average processing specification : Channel 1: Sampling processing : Channel 2: Average processing, number of times averaging (RWw3: 200 _H) |
| | CH. 2 average time, number of times setting: Channel 2: 16 times (RWw5: 10 _H) |
| | Initial data processing completion flag (RY18) is turned ON. |
| Initial data processing request flag (RX18) turns OFF | Initial data processing completion flag (RY18) is turned OFF. |
| Initial data setting completion flag (RX19) turns ON | Initial data setting request flag (RY19) is turned OFF. |

(d) Setting result (part 1)

The following indicates the setting result of the AJ65VBTCU-68ADV.

Remote device station initial setting: Procedure registration module 1: Target station 1

Input format:

| Execute Flag | Operational condition | Executorial condition | | | Details of execution | | |
|--------------|-----------------------|-----------------------|---------------|-------------------|----------------------|---------------|------------|
| | | Condition Device | Device Number | Execute Condition | Write Device | Device Number | Write Data |
| Execute | Set new | RX | 18 | ON | RWw | 00 | 0003 |
| Execute | Same as prev.set | RX | 18 | ON | RWw | 01 | 0031 |
| Execute | Same as prev.set | RX | 18 | ON | RWw | 03 | 0200 |
| Execute | Same as prev.set | RX | 18 | ON | RWw | 05 | 0010 |
| Execute | Same as prev.set | RX | 18 | ON | RY | 18 | ON |
| Execute | Same as prev.set | RX | 18 | ON | RY | 19 | ON |
| Execute | Set new | RX | 18 | OFF | RY | 18 | OFF |
| Execute | Set new | RX | 19 | ON | RY | 19 | OFF |

- (e) Selection of procedure registration (part 2)
Make setting for the AJ65VBTCU-68DAVN.
Click Procedure registration of target station number "4".

- (f) Setting of procedure registration (part 2)
Set the conditions and execution for the AJ65VBTCU-68DAVN.

When the initial data processing request flag (RX18) turns ON and Remote device station initialization procedure registration (SB0D) is set, the following data are registered to the AJ65VBTCU-68DAVN.

| Procedure Execution Condition in AJ65VBTCU-68DAVN | Execution Data |
|---|--|
| Initial data processing request flag (RX18) turns ON | Analog output enable/prohibit setting: Channel 1, 2: Enable (RWw8: 00FC _H) |
| | CH. 1 to CH. 4 input range setting : Channel 1: 0 to 5V : Channel 2: User range setting 1 (RWw9: 0031 _H) |
| | HOLD/CLEAR setting: Channel 1, 2: CLEAR (RWwB: 0 _H) |
| | Initial data processing completion flag (RY18) is turned ON. Initial data setting request flag (RY19) is turned ON. |
| Initial data processing request flag (RX18) turns OFF | Initial data processing completion flag (RY18) is turned OFF. |
| Initial data setting completion flag (RX19) turns ON | Initial data setting request flag (RY19) is turned OFF. |

- (g) Setting result (part 2)
The following indicates the setting result of the AJ65VBTCU-68DAVN.

Remote device station initial setting: Procedure registration module 1: Target station 4

Input format:

| Execute Flag | Operational condition | Executorial condition | | | Details of execution | | |
|--------------|-----------------------|-----------------------|---------------|-------------------|----------------------|---------------|------------|
| | | Condition Device | Device Number | Execute Condition | Write Device | Device Number | Write Data |
| Execute | Set new | RX | 18 | ON | RWw | 08 | 00FC |
| Execute | Same as prev.set | RX | 18 | ON | RWw | 09 | 0031 |
| Execute | Same as prev.set | RX | 18 | ON | RWw | 0B | 0000 |
| Execute | Same as prev.set | RX | 18 | ON | RY | 18 | ON |
| Execute | Same as prev.set | RX | 18 | ON | RY | 19 | ON |
| Execute | Set new | RX | 18 | OFF | RY | 18 | OFF |
| Execute | Set new | RX | 19 | ON | RY | 19 | OFF |

| |
|---|
| POINT |
| <p>(1) If the remote device station initialization procedure registration command (SB000D) is turned OFF after initial processing, all RY signals that turned ON in the initial procedure registration turn OFF. Hence, turn ON "CH. <input type="checkbox"/> analog output enable/prohibit flag (RYn0 to RYn7)" in the sequence program.</p> <p>(2) When the initial setting (analog output enable/prohibit setting (RWwn+8), CH. <input type="checkbox"/> output range setting (RWwn+9, RWwn+A), HOLD/CLEAR setting (RWw+B)), the remote device station initialization procedure registration function cannot be used. Change the initial setting in the sequence program.</p> <p>(3) When the remote device station initialization procedure registration function is not used but a sequence program is used to make setting, refer to the user's manual of the used master module.</p> |

5.4.3 Program example

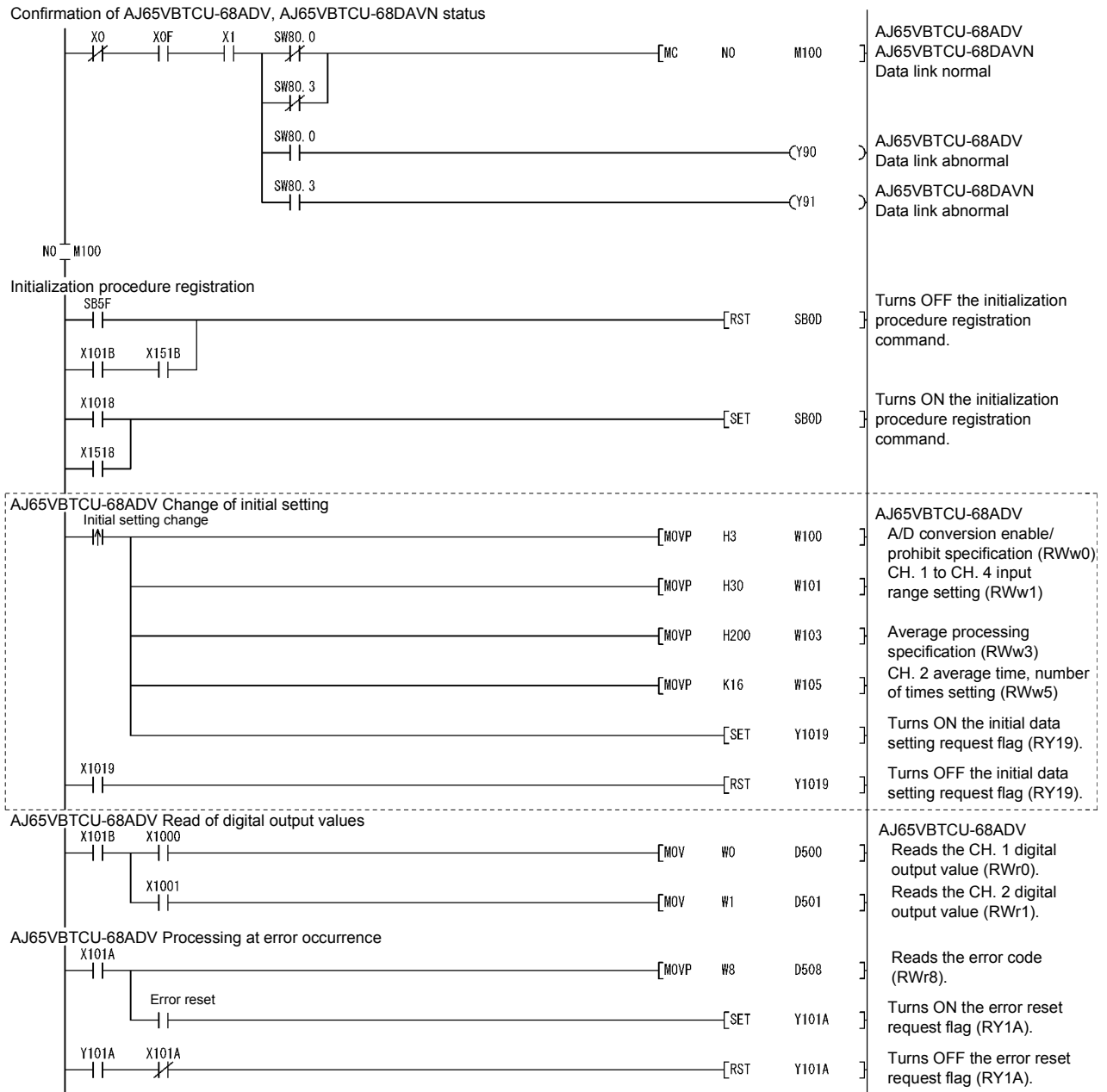

* The program part enclosed by the dotted line is required only when the initial setting is changed.

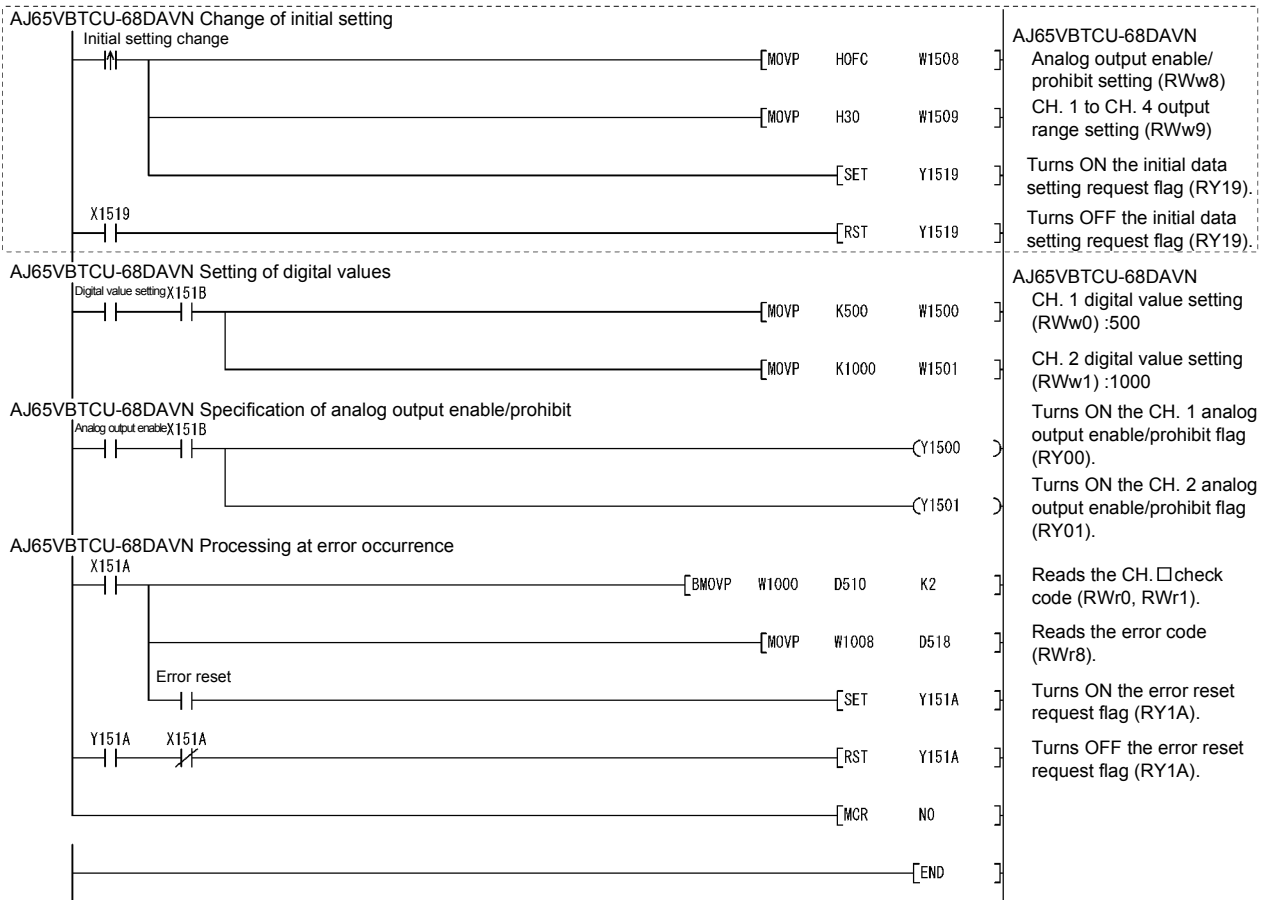

* The program part enclosed by the dotted line is required only when the initial setting is changed.

6 TROUBLESHOOTING

The details of the errors which may occur when using the AJ65VBTCU-68DAVN and troubleshooting are described.

6.1 Error Code List

When the data is written from the programmable controller CPU to the master module, and an error occurs (AJ65VBTCU-68DAVN "RUN" LED flashes), the error code is stored to the AJ65VBTCU-68DAVN remote register RWrn+8.

Table 6.1 Error Code List (Errors Detected by AJ65VBTCU-68DAVN)

| Error Code (Hexadecimal). | Cause | Corrective Action |
|------------------------------|--|---|
| 11 □ | The set digital value is outside the setting range. | Correct the digital value to within the setting range. |
| 20 □ | The output range setting is outside the setting range. | Correct the output range setting to within the setting range. |

The □ indicates the channel number where the error occurred.

- (1) For the digital value setting error, the "RUN" LED flickers at intervals of 0.5s and D/A conversion is performed using the upper or lower limit value.
For the output range setting error, the "RUN" LED flickers at intervals of 0.1s and D/A conversion is not performed on all channels.
- (2) When multiple errors occurred, the error code of the first error is stored, but the other errors are not stored.
- (3) The error code reset is performed by turning on the error reset request flag (RY (n+1) A).

6.2 Using the LED Indications to Check Errors

This section explains how to check errors using the LED indications of the AJ65VBTCU-68DAVN.

Refer to the programmable controller CPU and master module user's manual for issues regarding the programmable controller CPU and master module.

(1) When the AJ65VBTCU-68DAVN "POWER" LED is off

| Check Item | Corrective Action |
|--|--|
| Is 24VDC power on? | Check the external power supply. |
| Is the voltage of the 24VDC power supply within the specified value? | Set the voltage value to within the range 20.4 to 26.4V. |

(2) When the AJ65VBTCU-68DAVN "RUN" LED flickers

| Check item | | Corrective action |
|---|---|--|
| Is the LED flickering at 0.1s intervals in the normal mode? | When used as the ver. 1 remote device station (ver. 1 compatible slave station) | <ol style="list-style-type: none"> 1. Check that the mode select switch is not set to other than 0. (When the module is used as the ver. 1 remote device station, set the mode select switch to "0".) 2. Check the error code (RWm+8) to confirm the channel where the output range setting error occurred. 3. Correct the sequence program or GX Developer setting. |
| | When used as the ver. 2 remote device station (ver. 2 compatible slave station) | <ol style="list-style-type: none"> 1. Check that the mode select switch is not set to other than 3. (When the module is used as the ver. 2 remote device station, set the mode select switch to "3".) 2. Check the error code (RWm+8) to confirm the channel where the output range setting error occurred. 3. Correct the sequence program or GX Developer setting. |
| Is the LED flickering at 0.5s intervals in the normal mode? | | <ol style="list-style-type: none"> 1. Check that the mode select switch has not been moved from the position at power-on. (When the switch is returned to the original setting, the flickering LED is lit.) 2. Using the error code (RWm+8), check the channel at which the digital value setting error has occurred. 3. Check the check code (RWm to RWm+7) of the channel at which the error has occurred. 4. Make correction to the sequence program. |
| Is the LED flickering at 0.1s intervals in the test mode? | | Check that the mode select switch is not outside the setting range. |
| Is the LED flickering at 0.5s intervals in the test mode? | | Change the offset/gain adjustment to within the available setting range. |

(3) When the AJ65VBTCU-68DAVN "RUN" LED is off

| Check item | Corrective action |
|--|---|
| Is an attempt made to perform operation in the normal mode with the mode select switch set in the test mode? | Switch power on again after setting the mode select switch to the normal mode. |
| Has the watchdog timer error occurred? | Using the link special registers (SW0084 to SW0087) of the master module, check the watchdog timer error and power on the AJ65VBTCU-68DAVN again. If the "RUN" LED is not lit after power is switched on again, the possible cause is a hardware fault. Contact your nearest Mitsubishi representative. |

(4) When the AJ65VBTCU-68DAVN "L RUN" LED is off

Communications are broken.

For details, refer to troubleshooting in the user's manual of the master module used.

(5) When the AJ65VBTCU-68DAVN "L ERR." LED flickers at fixed intervals

| Check item | Corrective action |
|--|---|
| Has the station number or transmission speed setting switch position been changed during normal operation? | After correcting the setting switch setting, switch power on again. |
| Is the station number or transmission speed setting switch faulty? | If the "L ERR." LED has begun flickering though switch setting change was not made during operation, the possible cause is a hardware fault. Contact your nearest Mitsubishi representative. |

(6) When the AJ65VBTCU-68DAVN "L ERR." LED flickers at unfixed intervals

| Check item | Corrective action |
|---|--|
| Have you forgotten fitting the terminating resistor? | Check whether the terminating resistor is fitted. If it is not connected, connect it and switch power on again. |
| Is the module or CC-Link dedicated cable affected by noise? | Earth both ends of the shield wire of the CC-Link dedicated cable to the protective earth conductor via SLD and FG of the corresponding module. Earth the FG terminal of the module without fail. When carrying out wiring in piping, earth the pipe without fail. |

(7) When the AJ65VBTCU-68DAVN "L ERR." LED is on

| Check item | Corrective action |
|--|--|
| Are the station number and transmission speed correct? | Set the correct station number and transmission speed. |

6.3 Troubleshooting for the Case where the "ERR." LED of the Master Station Flickers

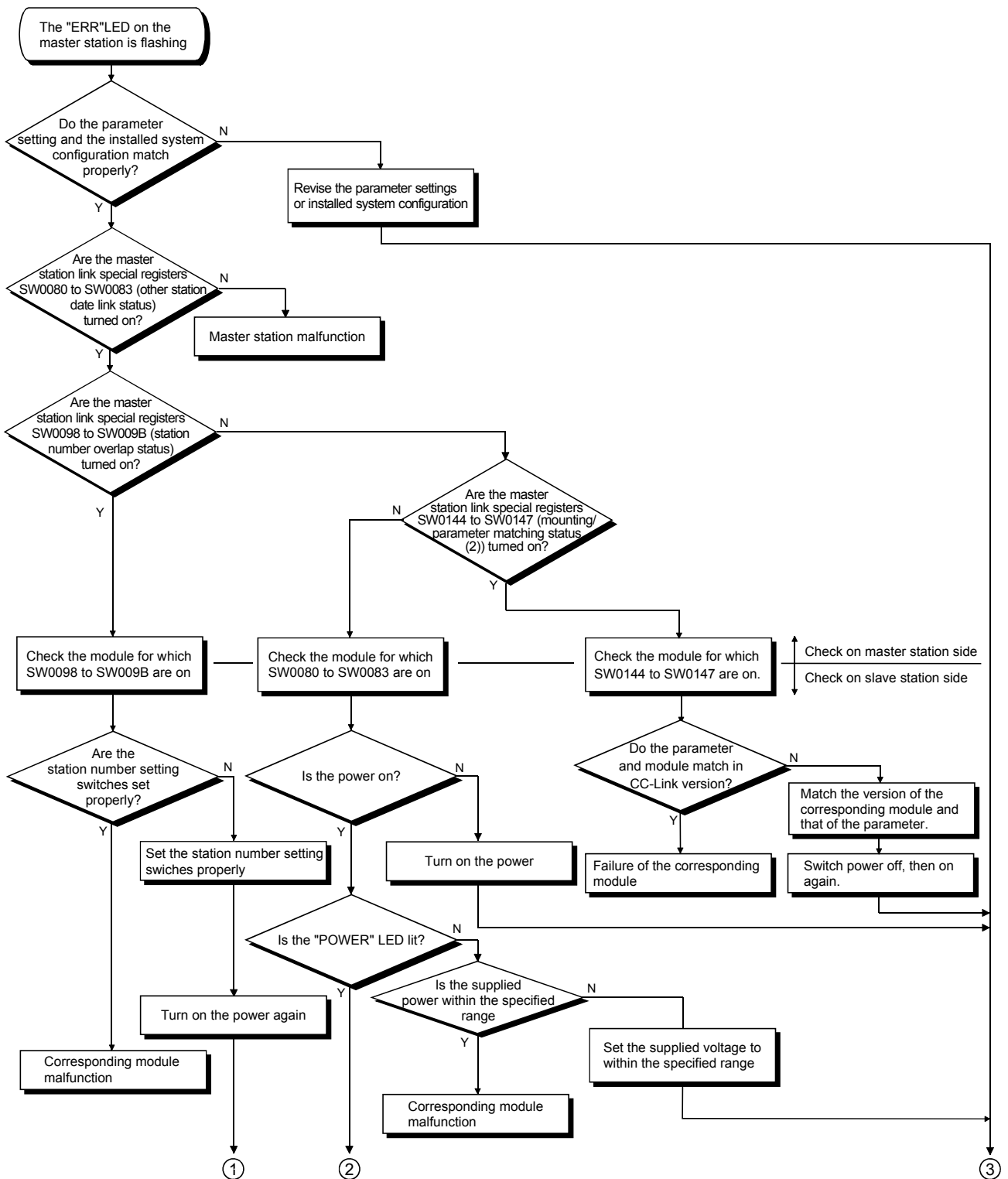

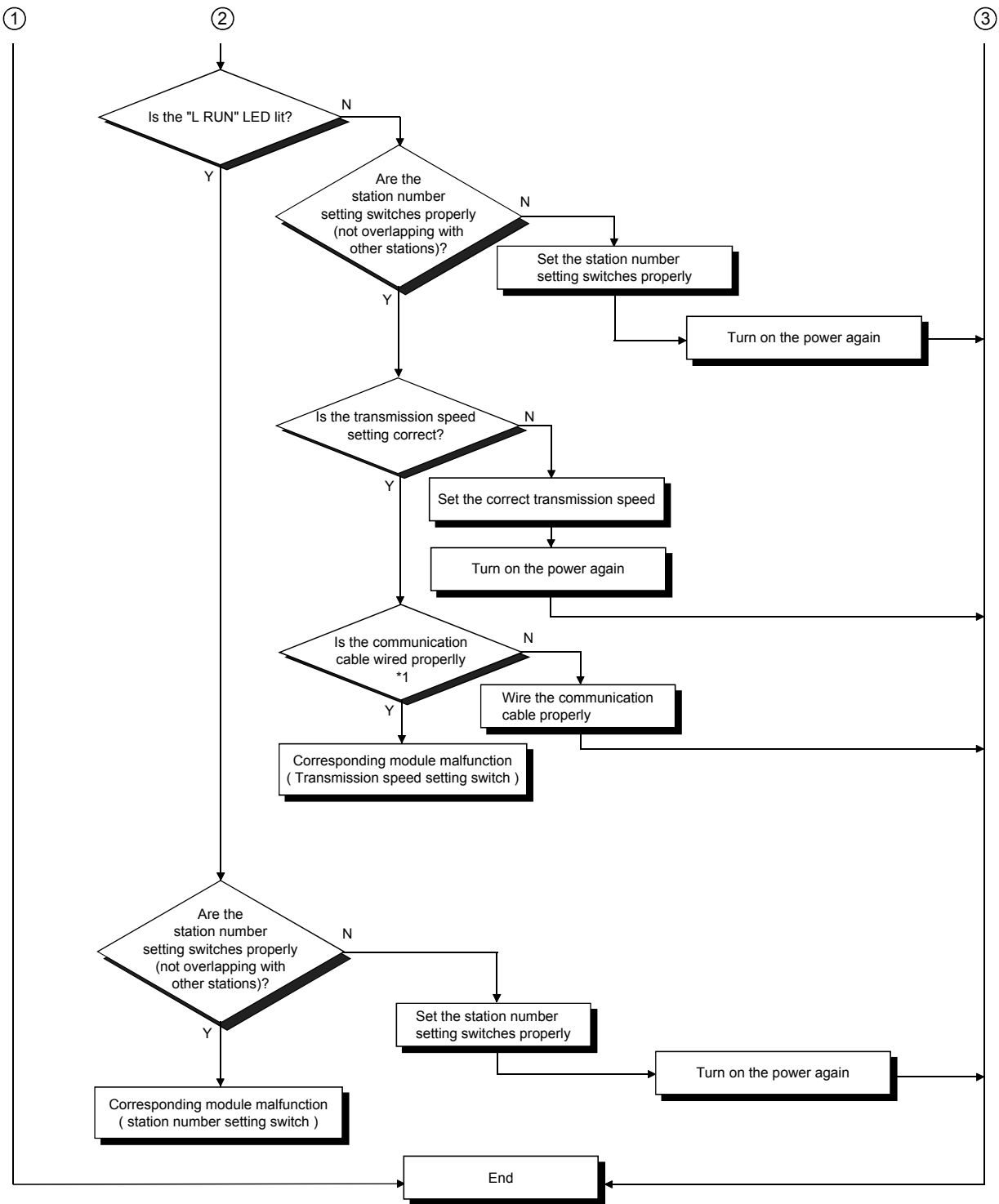

*1Check for a short, reversed connection, wire breakage, terminal resistor, FG connection, overall distance and station-to-station distance.

APPENDICES

Appendix 1 Comparison, Differences and Compatibility between New and Conventional Models

(1) Comparison between AJ65VBTCU-68DAV and AJ65VBTCU-68DAVN

The following table indicates the comparison between the AJ65VBTCU-68DAV and AJ65VBTCU-68DAVN.

Comparison between AJ65VBTCU-68DAV and AJ65VBTCU-68DAVN

| Item | AJ65VBTCU-68DAV | | AJ65VBTCU-68DAVN | |
|---|--|---|---|--|
| System compatibility (Station type, mode) | Ver. 1 remote device station (ver. 1 compatible slave station) or remote device station | | <ul style="list-style-type: none"> • Ver. 1 remote device station (ver. 1 compatible slave station) or remote device station • Ver. 2 remote device station (ver. 2 compatible slave station) | |
| | Remote net ver. 1 mode or remote net mode | | <ul style="list-style-type: none"> • Remote net ver. 1 mode or remote net mode • Remote net ver. 2 mode • Remote net additional mode | |
| Number of occupied stations | 3 stations (RX/Ry 32 points each, RWr/RWw 12 points each) | | Ver. 1 remote device station (ver. 1 compatible slave station) setting: 3 stations (RX/Ry 32 points each, RWr/RWw 12 points each) Ver. 2 remote device station (ver. 2 compatible slave station) setting: 1 station (RX/Ry 32 points each, RWr/RWw 16 points each) | |
| Operation status indicator LED/RUN LED | Normal mode | On : During normal operation Flicker : 0.1s intervals Input range setting error, mode select switch setting error 0.5s intervals Digital value setting error Off : 24VDC power off or watchdog timer error | Normal mode | On : During normal operation Flicker : 0.1s intervals Input range setting error, mode select switch setting error, or when this module is set as the ver. 2 remote device station (ver. 2 compatible slave station) and used with the remote net ver. 1 mode selected in the mode setting of the network parameter. 0.5s intervals Digital value setting error, or when the mode select switch setting is changed after power-on. Off : 24VDC power off or watchdog timer error |
| Mode select switch (factory setting "0") | AJ65VBTCU-68DAV | | AJ65VBTCU-68DAVN | |
| | 0: Normal mode 1: Test mode (user range setting 1) 2: Test mode (user range setting 2) 3 to 7: Reserved | | Ver. 1 remote device station (Ver. 1 compatible slave station) | 0: Normal mode 1: Test mode (user range setting 1) 2: Test mode (user range setting 2) |
| | | | Ver. 2 remote device station (Ver. 2 compatible slave station) | 3: Normal mode 4: Test mode (user range setting 1) 5: Test mode (user range setting 2) |
| | | | – | 6 to 7: Reserved |
| | | | | |



(2) Differences between AJ65VBTCU-68DAV and AJ65VBTCU-68DAVN

The AJ65VBTCU-68DAVN can be handled according to the system. (Refer to Section 4.4 for details.)

For the AJ65VBTCU-68DAV, the number of stations occupied by the module was 3 stations.

For the AJ65VBTCU-68DAVN, the number of stations occupied by the module can be handled as 1 station by setting the mode select switch of the module to the ver. 2 remote device station.

Further, for the AJ65VBTCU-68DAVN, the number of stations occupied by the module can also be handled as 3 stations, like the AJ65VBTCU-68DAV, by setting the mode select switch of the module to the ver. 1 remote device station.

In the system where the maximum number of connected stations of the master station exceeds 64 stations when the number of stations occupied by the AJ65VBTCU-68DAVN is handled as 3 stations, use of the AJ65VBTCU-68DAVN in the above setting can increase the number of connected remote device stations.

(3) Compatibility between AJ65VBTCU-68DAV and AJ65VBTCU-68DAVN

There is compatibility when the AJ65VBTCU-68DAVN is used as the ver. 1 remote device station in the existing system. (Refer to Section 4.4 for details.)

When the AJ65VBTCU-68DAV is replaced by the AJ65VBTCU-68DAVN in the existing system, the replacement can be made without the programs being modified since the remote I/O signals, remote registers, etc. are the same.

Set the mode select switch of the module to the ver. 1 remote device station and use the same station number.

| |
|---|
| POINT |
| To handle the AJ65VBTCU-68DAVN according to the system, the mode select switch of the module must be set, and at the same time, "mode setting" and "station information (station type)" in the network parameters of GX Developer must also be set. |
| Set the network parameters of GX Developer according to the system. |

Appendix 2 External dimension diagram

The outline dimension drawing of the AJ65VBTCU-68DAVN is shown below.

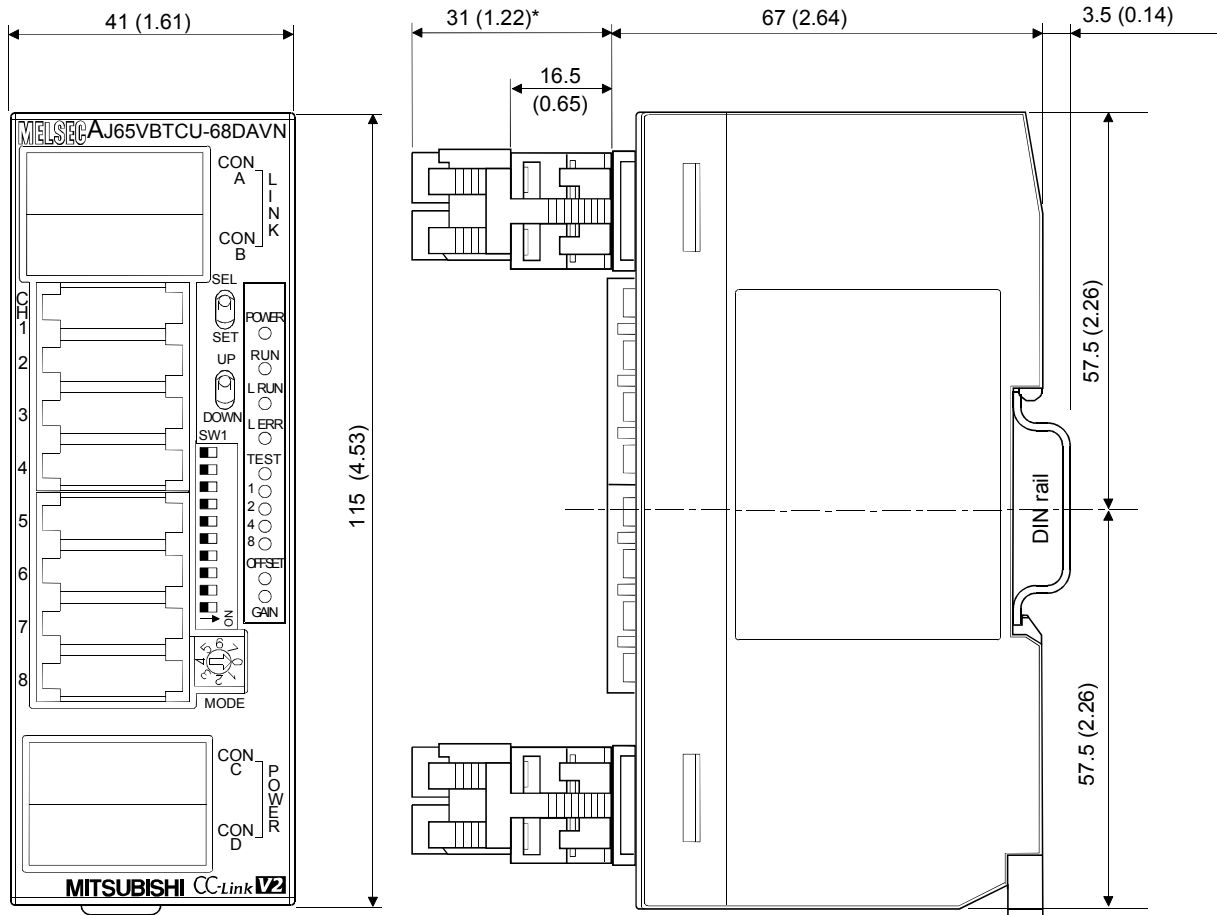

*:This section should be 14.5mm (0.57inch) when an online connector is not installed.

Unit : mm (inch)

INDEX

[A]

- Absolute maximum output 3-2
- Accuracy 3-2,3-5
- Allocation of the remote register 3-14
- Analog output 3-2
- Analog output enable/disable flag 3-13
- Analog output enable/disable setting 3-16
- Analog output status combination list 3-8
- Analog output value 3-5
- Applicable master module 2-3

[C]

- CC-Link dedicated cable 4-11,4-12
- CC-Link dedicated instruction 2-4
- Check code 3-18
- Comparison, differences and compatibility
between new and conventional models
..... APPX-1
- Conversion speed 3-6
- Current consumption 3-3
- Cyclic transmission 1-1

[D]

- D/A conversion enable/disable function 3-7
- D/A output enable/disable function 3-7
- Data link cable wiring 4-11
- Digital input 3-2
- Digital value setting 3-16
- DIN rail 3-2,4-2,4-5

[E]

- E²PROM write error flag 3-12
- Error code 3-18,6-1
- Error reset request flag 3-13
- Error status flag 3-12
- Expanded cyclic transmission 1-1
- External dimension diagram APPX-3
- External supply power 3-3

[F]

- Facing direction of the module installation ... 4-10
- Function list 3-7
- Function to specify hold or clear of the analog
output when the programmable controller CPU is
in the STOP status (HOLD/CLEAR setting) ... 3-7

[G]

- Gain value 3-3
- General specification 3-1

[H]

- HOLD/CLEAR setting 3-17

[I]

- I/O conversion characteristic 3-3
- Initial data processing complete flag 3-13
- Initial data processing request flag 3-12
- Initial data setting complete flag 3-12
- Initial data setting request flag 3-13

[M]

- Maintenance and inspection 4-25
- Maximum resolution 3-2
- Mode select switch 4-4
- Mode setting 2-3,4-6,4-7

[N]

- Name of each part 4-3
- Number of analog output points 3-2
- Number of occupied stations 3-2

[O]

- Offset value 3-3
- Offset/gain adjusting LED 4-4
- Offset/gain setting 4-8
- One-touch connector for analog I/O 4-5
- One-touch connector for communication 4-5
- One-touch connector for power supply and FG
..... 3-2
- Operation status display LED 4-4
- Output range changing function 3-7
- Output range setting 3-17
- Output short-circuit protection 3-2

[P]

- Performance specification 3-2
- Pre-Operation procedure 4-1
- Precautions when handling 4-1
- Program example for use of the ACPU/QCPU
(A mode)(dedicated instructions) 5-12

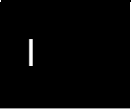

Program example for use of the ACPU/QCPU
(A mode)(FROM/TO instructions)..... 5-15
Program example for use of the QCPU(Q mode)
(when remote net ver. 1 mode is used)..... 5-1
Program example for use of the QnACPU ... 5-10
Programming procedure 5-1

[R]

Remote device station..... 2-3,3-2
Remote I/O signal list 3-9
Remote net additional mode
..... 1-3,2-2,2-3,4-7,5-25
Remote net ver. 1 mode 1-3,2-1,2-3,4-7,5-2
Remote net ver. 2 mode 1-3,2-2,2-4,4-7,5-17
Remote READY 3-12
Resolution..... 3-5

[S]

SELECT/SET switch 4-4
Station information2-3,4-6,4-7
Station number setting 4-10
Station number setting switch..... 4-5

[T]

Transmission speed setting switch..... 4-4
Troubleshooting..... 6-1
Troubleshooting for the case where the
"ERR." LED of the master station flickers 6-4

[U]

UP/DOWN switch..... 4-4
User range setting 3-4,4-4

[V]

Ver. 1 remote device station
.....2-3,3-2,3-9,4-4,4-6,4-8
Ver. 2 remote device station
.....2-3,3-2,3-9,4-4,4-6,4-8
Voltage output characteristic..... 3-4

[W]

Weight..... 3-3
Wiring..... 4-14
Wiring of module with external equipment ... 4-15

WARRANTY

Please confirm the following product warranty details before using this product.

1. Gratis Warranty Term and Gratis Warranty Range

If any faults or defects (hereinafter "Failure") found to be the responsibility of Mitsubishi occurs during use of the product within the gratis warranty term, the product shall be repaired at no cost via the sales representative or Mitsubishi Service Company.

However, if repairs are required onsite at domestic or overseas location, expenses to send an engineer will be solely at the customer's discretion. Mitsubishi shall not be held responsible for any re-commissioning, maintenance, or testing on-site that involves replacement of the failed module.

[Gratis Warranty Term]

The gratis warranty term of the product shall be for one year after the date of purchase or delivery to a designated place.

Note that after manufacture and shipment from Mitsubishi, the maximum distribution period shall be six (6) months, and the longest gratis warranty term after manufacturing shall be eighteen (18) months. The gratis warranty term of repair parts shall not exceed the gratis warranty term before repairs.

[Gratis Warranty Range]

- (1) The range shall be limited to normal use within the usage state, usage methods and usage environment, etc., which follow the conditions and precautions, etc., given in the instruction manual, user's manual and caution labels on the product.
- (2) Even within the gratis warranty term, repairs shall be charged for in the following cases.
 1. Failure occurring from inappropriate storage or handling, carelessness or negligence by the user. Failure caused by the user's hardware or software design.
 2. Failure caused by unapproved modifications, etc., to the product by the user.
 3. When the Mitsubishi product is assembled into a user's device, Failure that could have been avoided if functions or structures, judged as necessary in the legal safety measures the user's device is subject to or as necessary by industry standards, had been provided.
 4. Failure that could have been avoided if consumable parts (battery, backlight, fuse, etc.) designated in the instruction manual had been correctly serviced or replaced.
 5. Failure caused by external irresistible forces such as fires or abnormal voltages, and Failure caused by force majeure such as earthquakes, lightning, wind and water damage.
 6. Failure caused by reasons unpredictable by scientific technology standards at time of shipment from Mitsubishi.
 7. Any other failure found not to be the responsibility of Mitsubishi or that admitted not to be so by the user.

2. Onerous repair term after discontinuation of production

- (1) Mitsubishi shall accept onerous product repairs for seven (7) years after production of the product is discontinued. Discontinuation of production shall be notified with Mitsubishi Technical Bulletins, etc.
- (2) Product supply (including repair parts) is not available after production is discontinued.

3. Overseas service

Overseas, repairs shall be accepted by Mitsubishi's local overseas FA Center. Note that the repair conditions at each FA Center may differ.

4. Exclusion of loss in opportunity and secondary loss from warranty liability

Regardless of the gratis warranty term, Mitsubishi shall not be liable for compensation of damages caused by any cause found not to be the responsibility of Mitsubishi, loss in opportunity, lost profits incurred to the user by Failures of Mitsubishi products, special damages and secondary damages whether foreseeable or not, compensation for accidents, and compensation for damages to products other than Mitsubishi products, replacement by the user, maintenance of on-site equipment, start-up test run and other tasks.

5. Changes in product specifications

The specifications given in the catalogs, manuals or technical documents are subject to change without prior notice.

SH(NA)-080402E-F(1206)MEE

MODEL: AJ65V-68DAN-U-SY-E

MODEL CODE: 13JR66

MITSUBISHI ELECTRIC CORPORATION

HEAD OFFICE : TOKYO BUILDING, 2-7-3 MARUNOUCHI, CHIYODA-KU, TOKYO 100-8310, JAPAN
NAGOYA WORKS : 1-14, YADA-MINAMI 5-CHOME, HIGASHI-KU, NAGOYA, JAPAN

When exported from Japan, this manual does not require application to the
Ministry of Economy, Trade and Industry for service transaction permission.

Specifications subject to change without notice.