



**MITSUBISHI
ELECTRIC**

CC-Link System Optical Repeater Module

User's Manual

**AJ65SBT-RPS
AJ65SBT-RPG**

Thank you for buying the programmable controller MELSEC-A series.

Prior to use, please read this manual thoroughly and familiarize yourself with the product



MODEL	AJ65SBT-RPS/RPG-U
MODEL CODE	13JQ85
IB(NA)-0800089-N(1612)MEE	

● SAFETY PRECAUTIONS ●

(Read these precautions before using this product.)

Before using this product, please read this manual and the relevant manuals carefully and pay full attention to safety to handle the product correctly.

In this manual, the safety precautions are classified into two levels:

"⚠ WARNING" and "⚠ CAUTION".



Indicates that incorrect handling may cause hazardous conditions, resulting in death or severe injury.



Indicates that incorrect handling may cause hazardous conditions, resulting in minor or moderate injury or property damage.

Under some circumstances, failure to observe the precautions given under "⚠ CAUTION" may lead to serious consequences.

Observe the precautions of both levels because they are important for personal and system safety.

Make sure that the end users read this manual and then keep the manual in a safe place for future reference.

[Design Precautions]

WARNING

- Input/output could be switched on or off when a problem occurs in the repeater module.
So build an external monitoring circuit that will monitor any input/output signals that could cause a serious accident.

CAUTION

- Use the programmable controller in the environment that meets the general specifications contained in this Manual.
Using the programmable controller outside the range of the general specifications may result in electric shock, fire or malfunction, or may damage or degrade the module.
- Do not have control cables and communication cables bundled with or placed near by the main circuit and/or power cables. It may cause malfunction due to noise interference. Wire those cables at least 100mm(3.94 inch) away from the main circuit and/or power cables.

[Installation Precautions]

CAUTION

- Do not directly touch the module's conductive parts or electronic components.
Doing so may cause malfunctions or failure of the module.
- Tighten the module securely using DIN rail or installation screws within the specified torque range.
Loose terminal screws may cause falling, short circuit or erroneous operation.
If the terminal screws are too tight, it may cause falling or short circuit due to damage of the screws.

[Wiring Precautions]

WARNING

- Be sure to shut off all phases of the external power supply used by the system before installation or wiring. If the power is not disconnected at all phases an electric shock or product damage may result.

CAUTION

- Ground the FG terminal to the protective ground conductor dedicated to the programmable controller. Failure to do so will result in electric shock or malfunction.
- Be sure to tighten any unused terminal screws within a tightening torque range (0.42 to 0.50N·m). Failure to do so may cause a short circuit due to contact with a solderless terminal.
- Use applicable solderless terminals and tighten them with the specified torque. If any solderless spade terminal is used, it may be disconnected when the terminal screw comes loose, resulting in failure.
- Perform correct wiring for the module according to the product's rated voltage and terminal arrangement. Connecting to a power supply different from the rating or mis-wiring may cause fire and/or trouble.
- Fix terminal screws securely with the specified torque.
Loose terminal screws may cause short circuit or malfunction.
If the terminal screws are too tight, it may cause falling, short circuit or erroneous operation due to damage of the screws or module.
- Make sure foreign objects do not get inside the module, such as dirt and wire chips.
It may cause fire, trouble or malfunction.
- Be sure to fix the cables that are connected to the module in place, either by running them through a duct or by using clamps.
If the cables are not fixed in one of these ways, dispersion, movement, or careless pulling of the cables may cause damage to the module or cables, or malfunction due to cable contact faults.

[Wiring Precautions]

CAUTION

- When removing the cable from the module, do not pull the cable. When removing the cable with a connector, hold the connector on the side that is connected to the module.
When removing the cable connected to the terminal block, first loosen the screws on the part that is connected to the terminal block.
Pulling the cable that is still connected to the module may cause malfunction or damage to the module or cable.

[Startup and Maintenance Precautions]

WARNING

- Do not touch terminals when the power is on.
It may cause an electric shock or malfunction.

CAUTION

- Never try to disassemble or modify module.
It may cause trouble, malfunction, injury or fire.
- Do not drop or apply any strong impact to the module.
Doing so may damage the module.
- Be sure to shut off all phases of the external power supply used by the system before cleaning or retightening the terminal screws. If you do not switch off the external power supply, it will cause trouble or malfunction of the module.
- Be sure to fix the wires or cables by ducts or clamps when connecting them to the module.
Failure to do so may cause damage of the module or the cables due to accidental pull or unintentional shifting of the cables, or malfunctions due to poor contact of the cable.
- Do not install the control lines together with the communication cables, or bring them close to each other.
Failure to do so may cause malfunctions due to noise.
- Do not install/remove the terminal block more than 50 times after the first use of the product. (IEC 61131-2 compliant)
- Before handling the module, always touch grounded metal, etc. to discharge static electricity from the human body.
Failure to do so can cause the module to fail or malfunction.

[Disposal Precautions]

 **CAUTION**

- When disposing of this product, treat it as industrial waste.

● PRÉCAUTIONS DE SÉCURITÉ ●

(Lire ces précautions avant toute utilisation du produit.)

Avant d'utiliser ce produit, lire attentivement ce manuel ainsi que les manuels auxquels il renvoie, et toujours considérer la sécurité comme de la plus haute importance en manipulant le produit correctement.

Dans ce manuel, les précautions de sécurité sont classées en deux niveaux, à savoir : "⚠️ AVERTISSEMENT" et "⚠️ ATTENTION"

⚠️ AVERTISSEMENT

Attire l'attention sur le fait qu'une négligence peut créer une situation de danger avec risque de mort ou de blessures graves.

⚠️ ATTENTION

Attire l'attention sur le fait qu'une négligence peut créer une situation de danger avec risque de blessures légères ou de gravité moyennes ou risque de dégâts matériels.

Dans certaines circonstances, le non-respect d'une précaution de sécurité introduite sous le titre "⚠️ ATTENTION" peut avoir des conséquences graves. Les précautions de ces deux niveaux doivent être observées dans leur intégralité car elles ont trait à la sécurité des personnes et aussi du système. Veiller à ce que les utilisateurs finaux lisent ce manuel qui doit être conservé soigneusement à portée de main pour s'y référer autant que de besoin.

[Précautions lors de la conception]

AVERTISSEMENT

- *Les entrées/sorties peuvent se trouver activées ou désactivées par l'apparition d'un problème dans le module répéteur. On doit donc constituer un circuit de surveillance externe pour le suivi des signaux d'entrée/sortie qui pourraient être à l'origine d'accidents ou d'incidents graves.*

ATTENTION

- *Utiliser l'automate programmable dans un environnement en conformité avec les spécifications générales que présente ce manuel. L'utilisation de l'automate programmable hors des conditions prévues dans les spécifications générales peut être à l'origine d'un choc électrique, d'un départ de feu ou d'un dysfonctionnement, ou peut endommager ou détériorer l'appareil.*
- *Ne pas grouper ni placer à proximité les câbles de commande ou câbles de communication avec les câbles des circuits principaux et/ou d'alimentation. Cela pourrait produire des interférences à l'origine de dysfonctionnements. Installer ces câbles à une distance d'au moins 100mm (3,94 pouces) des câbles des circuits principaux et/ou d'alimentation.*

[Précautions d'installation]

ATTENTION

- *Éviter tout contact direct avec les parties conductrices ou les composants électroniques du module. Cela pourrait entraîner des dysfonctionnements ou une panne du module.*
- *Serrer le module fermement avec un rail DIN ou avec des vis de fixation serrées dans les limites du couple de serrage prescrit. Des vis de bornes desserrées peuvent tomber et être à l'origine de courts-circuits ou d'un fonctionnement erratique. Un serrage excessif des vis de borne risque de les endommager ces vis dont la chute risque de provoquer un court-circuit.*

[Précautions de câblage]

AVERTISSEMENT

- Avant installation ou câblage, toujours vérifier que les alimentations externes utilisées par le système ont été coupées sur toutes les phases. Si l'alimentation n'est pas déconnectée sur toutes les phases, il y a risque d'électrocution et d'endommagement du produit.

ATTENTION

- Mettre à la masse la borne FG pour le conducteur de mise à la terre protecteur dédié au contrôleur programmable. Faute de quoi, il y a risque d'électrocution ou de dysfonctionnement.
- Toujours serrer les vis des bornes inutilisées dans les limites du couple de serrage prescrit (0,42 à 0,50N•m). Faute de quoi, il y a risque de court-circuit par contact avec une borne sans soudure.
- Utiliser des bornes sans soudure de type approprié en les serrant dans les limites du couple de serrage prescrit. Une borne sans soudure dont la vis se desserre peut être une source de mauvais contact avec risque de panne.
- Effectuer le câblage du module correctement, en respectant la tension nominale et l'affectation des bornes du produit. Le raccordement à une source d'alimentation électrique différente de celle prescrite ou une erreur de câblage peut être à l'origine d'un départ de feu et/ou d'un dysfonctionnement.
- Bien serrer les vis de borne au couple de serrage prescrit.
Des vis de bornes desserrées peuvent être à l'origine de courts-circuits ou de dysfonctionnements.
Un serrage excessif peut endommager le module ou les vis qui risquent de tomber et de provoquer un court-circuit ou un fonctionnement erratique.
- Veiller à ce qu'aucun objet ou impureté, débris de fil ou autres, ne pénètre dans le module.
Cela peut être à l'origine d'un départ de feu, d'une panne ou d'un dysfonctionnement.
- Veiller à installer correctement les câbles connectés au module, soit en les faisant passer dans un conduit soit en utilisant des colliers de fixation.
Si les câbles ne sont pas fixés d'une façon ou d'une autre, la dispersion ou le déplacement des câbles ou une traction exercée par inadvertance sur un câble pourrait endommager le module ou les câbles et créer un mauvais contact à l'origine de dysfonctionnements.

[Précautions de câblage]

ATTENTION

- *Pour enlever un câble du module, ne pas tirer sur le câble proprement dit.
Pour enlever un câble muni de connecteurs, le saisir par le connecteur du côté du module.
Pour enlever un câble raccordé au bornier, commencer par desserrer les vis du point de fixation sur le bornier.
Tirer sur un câble encore raccordé au module peut endommager le câble ou le module et être à l'origine d'un dysfonctionnement.*

[Précautions de démarrage et de maintenance]

AVERTISSEMENT

- *Ne pas toucher aux bornes quand l'appareil est sous tension.
Cela pourrait être à l'origine d'une électrocution ou d'un dysfonctionnement.*

ATTENTION

- *Ne jamais tenter de démonter ou modifier le module.
Il y aurait risque de panne, dysfonctionnement, blessure ou départ de feu.*
- *Ne pas faire tomber le module, ni le soumettre à de forts chocs.
Cela risquerait d'endommager le module.*
- *Ne pas oublier de couper toutes les phases de l'alimentation externe utilisée par le système avant le nettoyage ou le resserrage des vis de bornes.
Négliger de couper l'alimentation externe peut être à l'origine d'une panne ou d'un dysfonctionnement du module.*
- *Tout câble ou fil raccordé au module doit être maintenu en place par un conduit ou des colliers de fixation.
Faute de quoi, il y a risque d'endommagement du module ou des câbles par ballonnement ou effort de traction exercé accidentellement sur les câbles, tout mauvais contact d'un câble pouvant être à l'origine de dysfonctionnement.*
- *Ne pas installer les lignes de commandes avec les câbles de communication et ne pas les placer à proximité les uns des autres.
Faute de quoi, les bruits parasites produiront des dysfonctionnements.*
- *Après la mise en service du produit, le nombre maximum admissible d'opérations de pose/retrait de la plaque à bornes est de 50 (selon IEC 61131-2).*
- *Avant de manipuler le module, toujours se décharger de la charge électrostatique dont le corps est porteur en touchant un objet métallique mis à la terre.
Faute de quoi, il y a risque de panne ou de dysfonctionnement du module.*

[Précaution de mise au rebut]

ATTENTION

- *Lors de sa mise au rebut, ce produit doit être traité comme un déchet industriel.*

● CONDITIONS OF USE FOR THE PRODUCT ●

- (1) Mitsubishi programmable controller ("the PRODUCT") shall be used in conditions;
- i) where any problem, fault or failure occurring in the PRODUCT, if any, shall not lead to any major or serious accident; and
 - ii) where the backup and fail-safe function are systematically or automatically provided outside of the PRODUCT for the case of any problem, fault or failure occurring in the PRODUCT.
- (2) The PRODUCT has been designed and manufactured for the purpose of being used in general industries.
MITSUBISHI SHALL HAVE NO RESPONSIBILITY OR LIABILITY (INCLUDING, BUT NOT LIMITED TO ANY AND ALL RESPONSIBILITY OR LIABILITY BASED ON CONTRACT, WARRANTY, TORT, PRODUCT LIABILITY) FOR ANY INJURY OR DEATH TO PERSONS OR LOSS OR DAMAGE TO PROPERTY CAUSED BY the PRODUCT THAT ARE OPERATED OR USED IN APPLICATION NOT INTENDED OR EXCLUDED BY INSTRUCTIONS, PRECAUTIONS, OR WARNING CONTAINED IN MITSUBISHI'S USER, INSTRUCTION AND/OR SAFETY MANUALS, TECHNICAL BULLETINS AND GUIDELINES FOR the PRODUCT.

("Prohibited Application")

Prohibited Applications include, but not limited to, the use of the PRODUCT in;

- Nuclear Power Plants and any other power plants operated by Power companies, and/or any other cases in which the public could be affected if any problem or fault occurs in the PRODUCT.
- Railway companies or Public service purposes, and/or any other cases in which establishment of a special quality assurance system is required by the Purchaser or End User.
- Aircraft or Aerospace, Medical applications, Train equipment, transport equipment such as Elevator and Escalator, Incineration and Fuel devices, Vehicles, Manned transportation, Equipment for Recreation and Amusement, and Safety devices, handling of Nuclear or Hazardous Materials or Chemicals, Mining and Drilling, and/or other applications where there is a significant risk of injury to the public or property.

Notwithstanding the above, restrictions Mitsubishi may in its sole discretion, authorize use of the PRODUCT in one or more of the Prohibited Applications, provided that the usage of the PRODUCT is limited only for the specific applications agreed to by Mitsubishi and provided further that no special quality assurance or fail-safe, redundant or other safety features which exceed the general specifications of the PRODUCTS are required. For details, please contact the Mitsubishi representative in your region.

REVISIONS

* The manual number is given on the bottom right of the top cover.

Print Date	* Manual Number	Revision
Nov., 1999	IB (NA)-0800089-A	First edition
Jun., 2000	IB (NA)-0800089-B	<u>Correction</u> Section 2.2(5)
Jan., 2001	IB (NA)-0800089-C	<u>Correction</u> Section 3.3.2(3)
Mar., 2005	IB (NA)-0800089-D	<u>Addition</u> Conformation to the EMC Directive and Low Voltage Instruction <u>Correction</u> SAFETY PRECAUTIONS, About the Manuals, Abbreviated names, generic names and terms, Chapter 1, Section 1.1, 2.1, 2.3, 3.1, 3.2, 3.3.1, 3.3.2, 3.4, 4.1, 4.2.1, 4.2.2, 4.3, 4.4, 4.7, 4.8, Chapter 5, Chapter 6
Mar., 2006	IB (NA)-0800089-E	<u>Correction</u> REVISIONS, Conformation to the EMC Directive and Low Voltage Instruction, Section 2.2, 2.3
Sep., 2006	IB (NA)-0800089-F	<u>Correction</u> SAFETY PRECAUTIONS
Dec., 2006	IB (NA)-0800089-G	<u>Correction</u> About the Manuals, Abbreviated names, generic name and terms, Section 2.3, 3.2, 3.3.1, 4.2.1
Jul., 2007	IB (NA)-0800089-H	<u>Correction</u> Section 4.3, Chapter 6
Jun., 2008	IB (NA)-0800089-I	<u>Correction</u> Compliance with the EMC Directive and the Low Voltage Directive, Chapter 1, Section 2.3, Section 3.2, 3.3.1, 3.4
Sep., 2009	IB (NA)-0800089-J	<u>Correction</u> SAFETY PRECAUTIONS , Section 2.3, 3.1, 3.2, 3.3.2, 4.2.1

* The manual number is given on the bottom right of the top cover.

Print Date	* Manual Number	Revision
Dec., 2011	IB (NA)-0800089-K	<p>[Addition] SAFETY PRECAUTIONS(Chinese), CONDITIONS OF USE FOR THE PRODUCT</p> <p>[Correction] SAFETY PRECAUTIONS, About the Manuals, COMPLIANCE WITH EMC AND LOW VOLTAGE DIRECTIVES, Section 3.1, 4.2.1, 4.7</p>
Apr., 2012	IB (NA)-0800089-L	<p>[Correction] Section 3.2</p>
Nov., 2014	IB (NA)-0800089-M	<p>[Addition] Section 2.3</p> <p>[Correction] Related Manual, ABBREVIATED NAMES, GENERIC NAMES AND TERMS, Section 2.4, 3.2, 3.3.1, 4.3, Chapter 6,</p> <p>[Change] from Section 2.3 to Section 2.4</p>
Dec., 2016	IB (NA)-0800089-N	<p>[Addition] SAFETY PRECAUTIONS (French)</p> <p>[Correction] Section 3.1, 4.3, Chapter 6</p>

This manual confers no industrial property rights or any rights of any other kind, nor does it confer any patent licenses. Mitsubishi Electric Corporation cannot be held responsible for any problems involving industrial property rights which may occur as a result of using the contents noted in this manual.

CONTENTS

1. OVERVIEW	20
1.1 Features.....	20
2. SYSTEM CONFIGURATION	22
2.1 Total configuration	22
2.2 Checking hardware versions.....	23
2.3 Checking serial number	23
2.4 Cautions on system configuration.....	24
3. SPECIFICATIONS	32
3.1 General specifications.....	32
3.2 Performance specifications.....	34
3.3 Specifications of connection cables	36
3.3.1 CC-Link dedicated cable	36
3.3.2 Optical fiber cable specifications	36
3.4 Max. transmission distance.....	38
4. PROCEDURE UP TO START OF DATA LINK	39
4.1 Procedure up to start of data link	39
4.2 Mounting and installation	40
4.2.1 Cautions on handling.....	40
4.2.2 Installation environment	41
4.3 Names and settings of parts	42
4.4 Check of module state (Hardware test)	45
4.5 Setting of switches	46
4.6 Installation and removal of protective cover.....	47
4.7 Connection of module through cable	48
4.8 Check for state of connection (Line test)	50
5. TROUBLESHOOTING	52
6. EXTERNAL DIMENSIONS.....	57

ABOUT THE MANUALS

The following manuals are related to this product.
Referring to this list, please request the necessary manuals.

Related Manual

Manual name	Manual Number (Model code)
MELSEC iQ-R CC-Link System Master/Local Module User's Manual (Startup)	SH-081269ENG 13JX10
MELSEC iQ-R CC-Link System Master/Local Module User's Manual (Application)	SH-081270ENG 13JX19
MELSEC-Q CC-Link System Master/Local Module User's Manual	SH-080394E (13JR64)
MELSEC-L CC-Link System Master/Local Module User's Manual	SH-080895ENG 13JZ41
CC-Link System Master/Local Module Type AJ61QBT11/A1SJ61QBT11 User's Manual	IB-66722 (13J873)
CC-Link System Master/Local Module Type AJ61BT11/A1SJ61BT11 User's Manual	IB-66721 (13J872)
CC-Link System Repeater (T-junction) Module User's Manual AJ65SBT-RPT	IB-0800078 (13JQ81)
CC-Link System Space Optical Repeater Module User's Manual AJ65BT-RPI-10A/AJ65BT-RPI-10B	IB-0800090 (13JQ86)
CC-Link System Low Profile Waterproof Type Repeater Hub Module User's Manual AJ65FBTA-RPH	IB-0800288 (13JP55)
CC-Link System Spring Clamp Terminal Block Type Repeater Hub Module User's Manual AJ65BTS-RPH	IB-0800346 (13JP97)

COMPLIANCE WITH EMC AND LOW VOLTAGE DIRECTIVES

(1) Method of ensuring compliance

To ensure that Mitsubishi programmable controllers maintain EMC and Low Voltage Directives when incorporated into other machinery or equipment, certain measures may be necessary.

Please refer to one of the following manuals.

- User's manual for the CPU module or head module used
- Safety Guidelines (this manual is included with the CPU module, base unit, or head module)

The CE mark on the side of the programmable controller indicates compliance with EMC and Low Voltage Directives.

(2) Additional measures

To ensure that this product maintains EMC and Low Voltage Directives, please refer to one of the manuals listed under (1).

ABBREVIATED NAMES, GENERIC NAMES AND TERMS

Abbreviated names, generic names and terms	Description
AJ65SBT-RPS/RPG	Abbreviation of AJ65SBT-RPS/AJ65SBT-RPG type CC-Link system optical repeater module.
AJ65SBT-RPT	Abbreviation of AJ65SBT-RPT type CC-Link system repeater (T-junction) module.
AJ65FBTA-RPH	Abbreviation of AJ65FBTA-RPH type CC-Link system low profile waterproof type repeater hub module.
AJ65BTS-RPH	Abbreviation of AJ65BTS-RPH type CC-Link system spring clamp terminal block type repeater module.
AJ65BT-RPI-10A/10B	Abbreviation of AJ65BT-RPI-10A/AJ65BT-RPI-10B type CC-Link system space optical repeater module.
Engineering tool	Generic name of GX Developer, GX Works2, and GX Works3
Master station	A station that controls the entire system. This station can perform cyclic transmission and transient transmission with all stations. Only one master station can be used in a system.
Local station	A station that performs cyclic transmission and transient transmission with the master station and other local stations.
Remote I/O station	A station that exchanges I/O signals (bit data) with the master station by cyclic transmission. This station cannot perform transient transmission.
Remote device station	A station that exchanges I/O signals (bit data) and I/O data (word data) with the master station by cyclic transmission. This station cannot perform transient transmission.
Remote station	Generic name of a remote I/O station and a remote device station
Intelligent device station	A station that exchanges I/O signals (bit data) and I/O data (word data) with another station by cyclic transmission. This station responds to a transient transmission request from another station and also issues a transient transmission request to another station.
Master module	Generic name of modules that can serve as a master station
Local module	Generic name of modules that can serve as a local station
Remote module	Modules that can serve as a remote I/O station, remote device station, and intelligent device station. Generic name of AJ65BTB□□□□□, AJ65BTC□□□□, AJ65BT-64AD, AJ65BT-64DAV, and AJ65BT-64DAI
Segment	System between terminating resistor connected to each other through cross-over cables. The conventional CC-Link system can be said to be configured with one segment (See Section 2.1.).
Repeater	Module for expanding the CC-Link system by connecting the segments to each other.
Transient transmission	A function of communication with another station, which is used when requested by a dedicated instruction or an engineering tool
Cyclic transmission	A function by which data are periodically exchanged among stations on the same system using link devices

PRODUCT STRUCTURE

The product structure of AJ65SBT-RPS/RPG is given in the table below.

Part name	Quantity
AJ65SBT-RPS/RPG module	1
Terminating resistor 110 Ω 1/2W (Brown, Brown, Brown)	1
Terminating resistor 130 Ω 1/2W (Brown, Orange, Brown)	1

1. OVERVIEW

This User's Manual describes the specifications, part names, settings and others of the AJ65SBT-RPS type CC-Link system optical repeater module (for SI/H-PCF/Broad-band H-PCF/QSI optical fiber cables) and the AJ65SBT-RPG type CC-Link system optical repeater module (for GI optical fiber cables) used in the CC-Link system.

1.1 Features

The AJ65SBT-RPS/RPG module is used to increase the flexibility of laying the cables of the CC-Link system.

Using two the same product of AJ65SBT-RPS/RPG enables a transmission distance increase and T-junction wiring using optical fiber cables in all CC-Link systems.

In addition, using optical fiber cables facilitates avoiding the noise trouble of the transmission path, improving system stability.

(1) Extended transmission distance in CC-Link system

Use of this module increases the transmission distance of the CC-Link system.

In addition, use of multiple modules enables the transmission distance to be increased up to 3 stages (up to 2 stages when the AJ65SBT-RPGs are used).

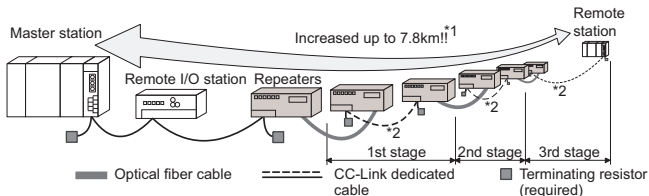

*1 The maximum transmission distance on the assumption that the transmission speed setting is 156kbps in a system only the AJ65SBT-RPSs are used as repeaters.

*2 Though not shown here, the other remote stations can be connected between the repeaters.

(2) Enabled T-junction wiring in CC-Link system

Arrangement of these modules between the CC-Link system modules enables the CC-Link system to be wired in the form of T-junction.

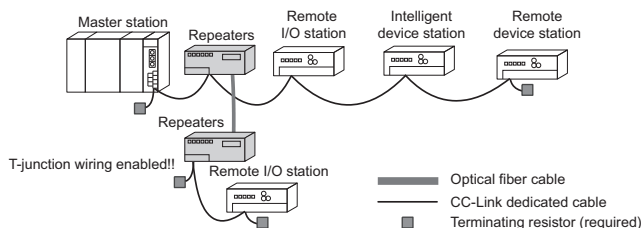

(3) Noise-resistant stable system

Optical fiber cables used for junction and extension make it easy to avoid trouble caused by noise, improving system stability.

(4) Mountable to control panel with either screws or DIN rail

This module can be mounted onto the control panel with either screws or DIN rail.

(5) Compact module size

The module size has been reduced to the same one as that of AJ65SBTC4-16 □ / AJ65SBTC1-32 □ type small remote I/O module.

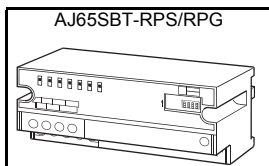

Item	Size
Height	50 mm (1.97 inch)
Width	118 mm (4.65 inch)
Depth	40 mm (1.58 inch)

2. SYSTEM CONFIGURATION

2.1 Total configuration

The total configuration employed when the AJ65SBT-RPS/RPG module is used is as shown below.

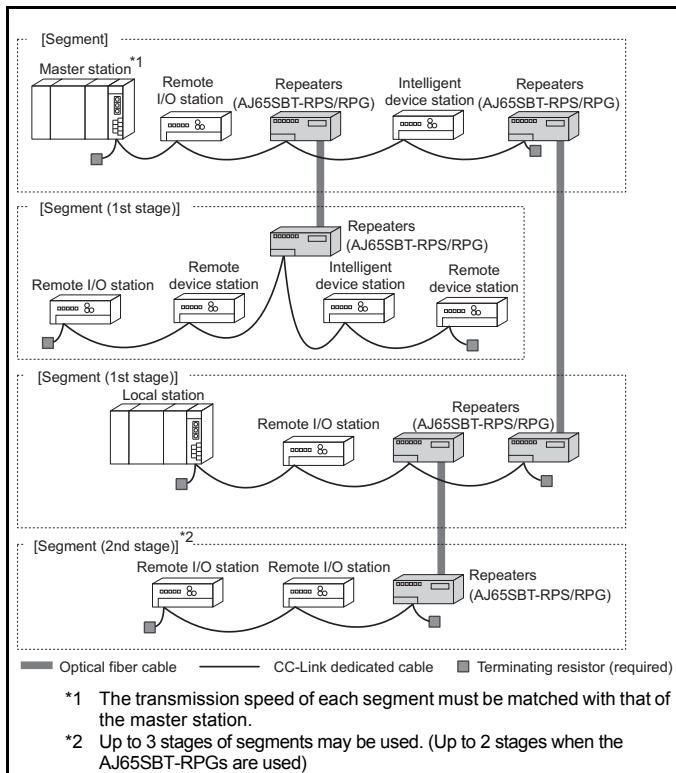

2.2 Checking hardware versions

The hardware versions of the AJ65SBT-RPS/RPG can be checked on the DATE section on the rating plate, which is situated on the side on the module.

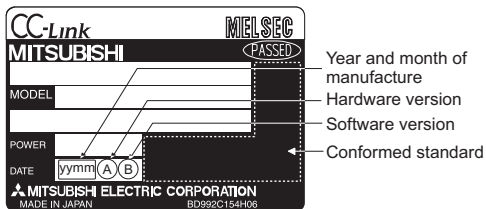

2.3 Checking serial number

The serial number of the AJ65SBT-RPS/RPG can be checked on the SERIAL section on the rating plate.

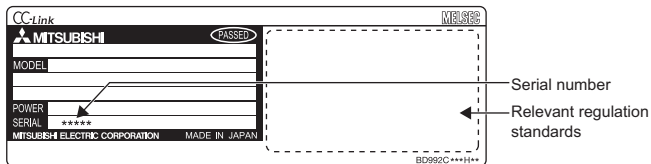

2.4 Cautions on system configuration

(1) Conditions of usable master module

When the AJ61BT11, A1SJ61BT11, AJ61QBT11 and A1SJ61QBT11 modules are used, those of the functional version B or later must be employed. Use the master module bearing the version 9707 B or later in the DATE column of the rating plate as shown in the figure below.

When the RJ61BT11, QJ61BT11N, QJ61BT11, LJ61BT11 module is used, any module can be used irrespective of the version.

(a) Rating plate of AJ61BT11 or AJ61QBT11

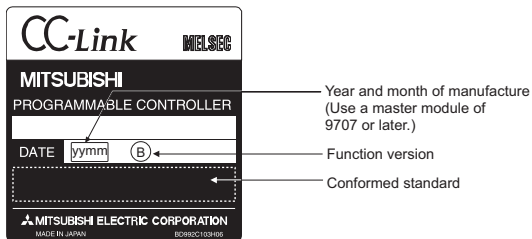

(b) Rating plate of A1SJ61BT11 or A1SJ61QBT11

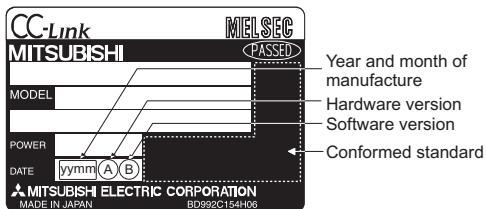

- (2) Max. number of modules connected to configure CC-Link system
Up to 64 modules of repeaters can be connected in one segment.
In the CC-Link system where repeaters are used, also the number of remote stations capable of being controlled by one master station is the same as in the other systems.
For details, refer to the User's Manual of the applicable master module.
- (3) Combination of optical repeater modules and optical fiber cable used
Use the optical repeater modules and fiber-optic cable in the following combination.

Module	Optical fiber Cable
AJ65SBT-RPS	SI type optical fiber cable (max. extension distance of cable: 500m (1639.34ft.))
	H-PCF/Broad-band H-PCF/QSI type optical fiber cable (max. extension distance of cable: 1000m (3278.69ft))
AJ65SBT-RPG	G1 type optical fiber cable (max. extension distance of cable: 2000m (6557.38ft.))

Example: Combination for use of AJ65SBT-RPG

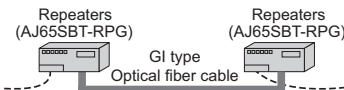

- (4) Max. number of stages connected to configure segment
 Use of the AJ65SBT-RPS enables communication between the master station and a remote station located up to three segments away from the master station segment, and use of the AJ65SBT-RPG enables communication between the master station and a remote station located up to two segments away from the master station segment.
 If the system includes both the AJ65SBT-RPS and AJ65SBT-RPG, however, up to two stages can be placed.

[System using only AJ65SBT-RPSs]

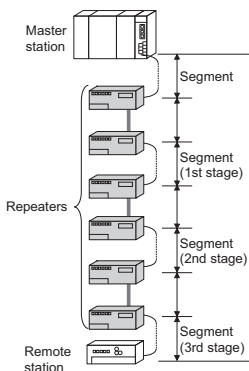

[System using AJ65SBT-RPGs only, or including both AJ65SBT-RPS and AJ65SBT-RPG]

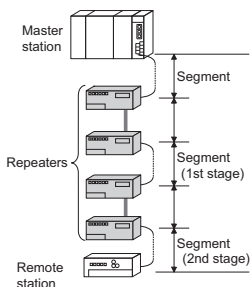

- (5) Instructions for using different models of repeaters in combination
 Note that when combining the repeaters of different models, there are the following restrictions on the number of connectable repeaters and the number of connected stages.

Combination pattern	Max. number of repeaters						Max. number of stages
	AJ65BTS-RPH	AJ65FBT A-RPH	AJ65SBT-RPH	AJ65SBT-RPS	AJ65SBT-RPG	AJ65BT-RPI-10A/10B	
1)	1	—	2	—	—	—	3
	—	1	2	—	—	—	
2)	1	—	—	2(1 set)	—	—	2
	1	—	—	—	2(1 set)	—	
	—	1	—	2(1 set)	—	—	
	—	1	—	—	2(1 set)	—	
3)	1	—	—	—	—	2(1 set)	
	—	1	—	—	—	2(1 set)	
4)	—	—	2	4(2 set)	—	—	4
5)	—	—	2	—	2(1 set)	—	3
6)	—	—	2	—	—	2(1 set)	
7)	—	—	—	2(1 set)	2(1 set)	—	2
8)	—	—	—	2(1 set)	—	2(1 set)	
	—	—	—	—	2(1 set)	2(1 set)	
9)	1	1	—	—	—	—	

POINT

- For the CC-Link system, up to 2 repeater types can be used in combination. Using 3 models or more is not allowed.
- When repeaters are connected in the same segment by link wiring, up to 64 modules can be connected.

For details, refer to the user's manual of the master module used.

Ex.) A CC-Link system with combination pattern 7) is built

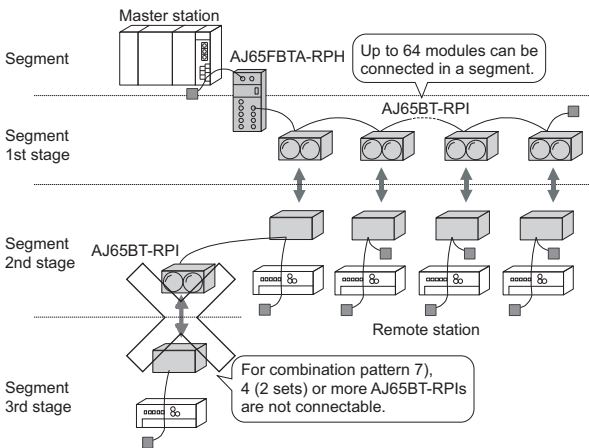

(a) Combination pattern 1)

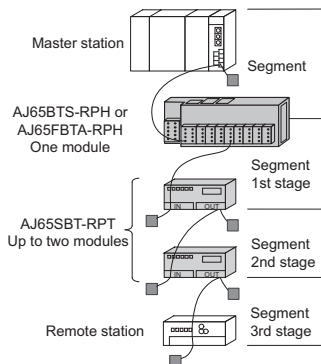

(b) Combination pattern 2)

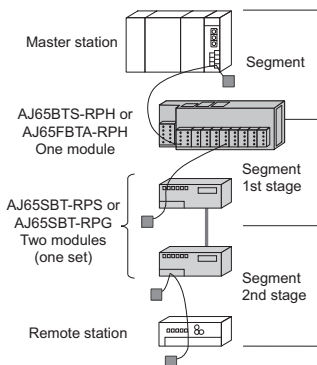

(c) Combination pattern 3)

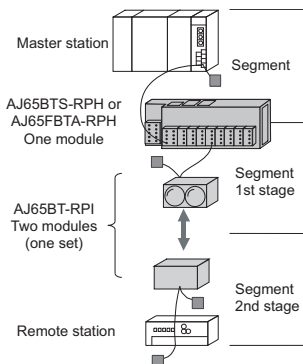

(d) Combination pattern 4)

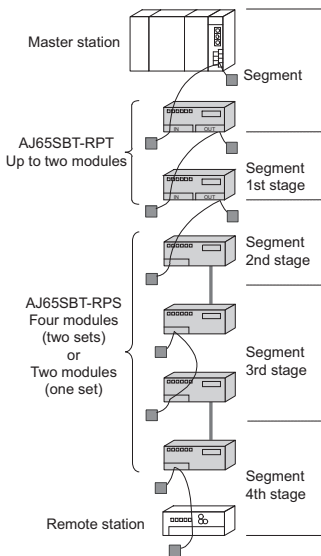

(e) Combination pattern 5)

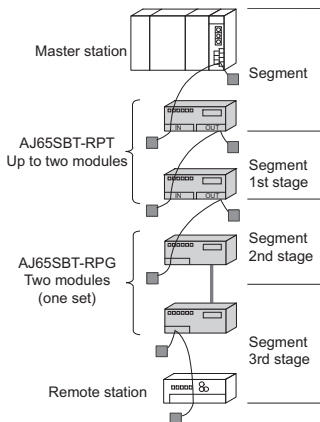

(g) Combination pattern 7)

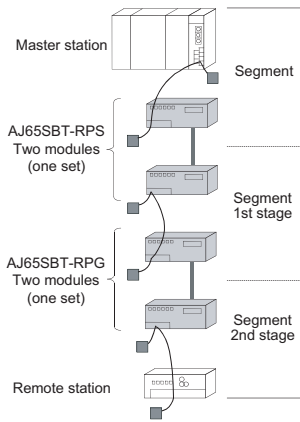

(f) Combination pattern 6)

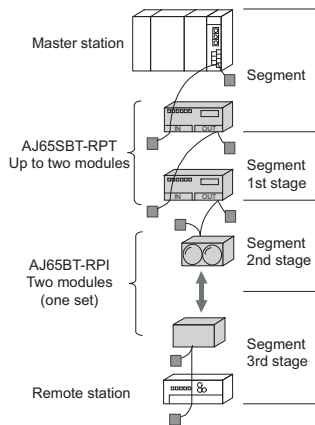

(h) Combination pattern 8)

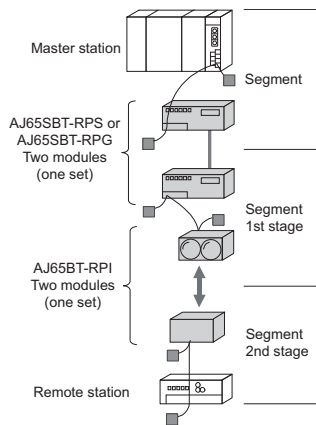

(i) Combination pattern 9)

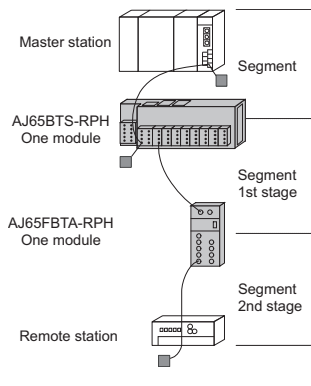

3. SPECIFICATIONS

3.1 General specifications

The general specifications of the AJ65SBT-RPS/RPG are shown below.

Item	Specifications					
Operating ambient temperature <i>Température ambiante de fonctionnement</i>	0 to 55 °C 0 à 55 °C					
Storage ambient temperature	-20 to 75 °C					
Operating ambient humidity	10 to 90%RH, non-condensing					
Storage ambient humidity						
Vibration resistance	Compliant with JIS B 3502 and IEC 61131-2		Frequency	Constant acceleration	Half amplitude	Sweep Count
		Under intermittent vibration	5 to 8.4 Hz	—	3.5 mm	10 times each in X, Y, Z directions
			8.4 to 150Hz	9.8 m/s ²	—	
		Under continuous vibration	5 to 8.4 Hz	—	1.75 mm	—
8.4 to 150Hz	4.9 m/s ²		—			
Shock resistance	Compliant with JIS B 3502 and IEC 61131-2 (147 m/s ² , 3 times each in 3 directions X, Y, Z)					
Operating atmosphere	No corrosive gases					
Operating altitude *3	0 to 2000m					
Installation location	Inside a control panel *4					
Overvoltage category *1	II or less					
Pollution degree *2	2 or less					

- *1 This indicates the section of the power supply to which the equipment is assumed to be connected between the public electrical power distribution network and the machinery within premises.
Category II applies to equipment for which electrical power is supplied from fixed facilities. The surge voltage withstand level for up to the rated voltage of 300V is 2500V.
- *2 This index indicates the degree to which conductive material is generated in terms of the environment in which the equipment is used.
Pollution level 2 is when only non-conductive pollution occurs. A temporary conductivity caused by condensing must be expected occasionally.
- *3 Do not use or store the programmable controller under pressure higher than the atmospheric pressure of altitude 0m. Doing so may cause malfunction. When using the programmable controller under pressure, please consult your local Mitsubishi Electric representative.
- *4 It can also be used in an environment other than on the control panel if the conditions such as usage ambient temperature and humidity are satisfied.

3.2 Performance specifications

The performance specifications of the AJ65SBT-RPS/RPG are shown below.

Item			Specifications	
			AJ65SBT-RPS	AJ65SBT-RPG
Common specifications	Power supply	Voltage	20.4 to 26.4 VDC	
		Current	60.0mA (at TYP. 24VDC)	
	Noise immunity		Simulator noise of 500Vp-p, obtained by a noise simulator of 1μs noise width and 25 to 60Hz noise frequency	
	Dielectric withstand voltage		500VAC for 1 minute between all DC external terminals and ground	
	Insulation resistance		10MΩ or higher, measured with a 500VDC insulation resistance tester	
	Weight		0.2kg	
	External connection	Communication area, module power supply	7-point 2-piece terminal block [transmission circuit, module power supply, FG] M3 × 5.2 Tightening torque: 0.59 to 0.88N·m Applicable solderless terminals: 2 max.	
Applicable solderless terminals		<ul style="list-style-type: none"> • RAV1.25-3 (conforming to JIS C 2805) [Applicable wire size :0.3 to 1.25mm²] • V2-MS3, RAP2-3SL, TGV2-3N [Applicable wire size: 1.25 to 2.0mm²] 		
CC-Link communication specifications	Transmission speed		Selectable from among 156kbps, 625kbps, 2.5Mbps, 5Mbps and 10Mbps	
	Max. number of stages connected to configure segment	AJ65SBT-RPS only (Refer to Section 2.4 (4))		3 stages
		AJ65SBT-RPG only (Refer to Section 2.4 (4))		2 stages
		<ul style="list-style-type: none"> • Combination of AJ65SBT-RPS and AJ65SBT-RPG • Combination of AJ65SBT-RPG/AJ65SBT-RPS and one of AJ65FBTA-RPH, AJ65BTS-RPH, or AJ65BT-RPI. (Refer to Section 2.4 (5)) 		2 stages
		Combination of AJ65SBT-RPS and AJ65SBT-RPT (Refer to Section 2.4 (5))		4 stages
		Combination of AJ65SBT-RPG and AJ65SBT-RPT (Refer to Section 2.4 (5))		3 stages
	Max. transmission distance of each segment		Varies according to transmission speed. (Refer to Section 3.4)	
	Max. number of modules connected		64 (Refer to Section 2.4 (2) for the conditions for the number of modules connected)	
Number of stations occupied		0 (none)		
Settable station number		No station numbers		

Item		Specifications	
		AJ65SBT-RPS	AJ65SBT-RPG
Optical communication specifications	Max. transmission distance of optical fiber cable between repeaters	SI optical fiber cable: 500m H-PCF/ Broadband H-PCF/ QSI optical fiber cable: 1000m	GI optical fiber cable: 2000m

3.3 Specifications of connection cables

3.3.1 CC-Link dedicated cable

Use the CC-Link dedicated cable for the CC-Link system. If a cable other than the CC-Link dedicated cable is used, the performance of the CC-Link system cannot be guaranteed.

For the specifications of the CC-Link dedicated cables or any other inquiries, visit the following site:

CC-Link Partner Association website: www.cc-link.org

Remark

For details, refer to the CC-Link cable wiring manual issued by the CC-Link Partner Association.

3.3.2 Optical fiber cable specifications

For details of the AJ65FBTA-RPH, AJSBT-RPT and/or AJ65BT-RPI-10A/-10B, refer to the respective user's manual. Confirm the details of the optical fiber specifications by the cable that is being used.

The optical fiber cables and connectors are dedicated parts. Optical fiber cable with connectors are sold by Mitsubishi System Service. (A catalogue of optical fiber cables is available.)

Mitsubishi System Service can also provide installation. Contact your nearest representative for details.

Item	SI (Multi-particulate glass)	H-PCF (Plastic-clad)	Broad band H-PCF (Plastic-clad)	QSI (Quartz glass)	GI-50/125 (Quartz glass)
Max. transmission distance	500 m	1 km	1 km	1 km	2 km
Transmission loss	12 dB/km	6 dB/km	5 dB/km	5.5 dB/km	3 dB/km
Core diameter	200 μ m	200 μ m	200 μ m	185 μ m	50 μ m
Clad diameter	220 μ m	250 μ m	250 μ m	230 μ m	125 μ m
Primary membrane	250 μ m	—	—	250 μ m	—
Applicable connector	F06/F08 or equivalent (JIS C 5975/5977 conformance)				

Remark

Prepare the following types of optical fiber cables.

A type: Cable for connection inside control panel.

B type: Cable for connections between outside control panels.

C type: Cable for outdoor connections.

D type: Cable for outdoor connections that have been reinforced.

There are special cables available for moveable applications and resistance to heat. Contact your Mitsubishi System Service for details.

3.4 Max. transmission distance

[System using only AJ65SBT-RPSs]

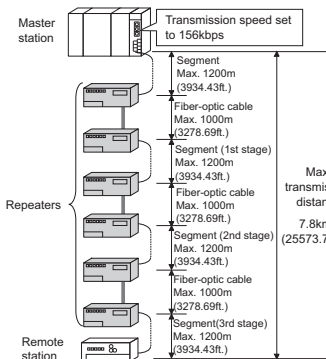

[System using AJ65SBT-RPGs only, or including both AJ65SBT-RPS and AJ65SBT-RPG]

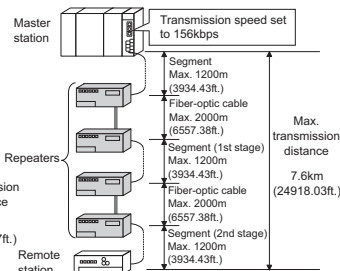

*When H-PCF/Broad-band H-PCF/QSI type optical fiber cables are used

Conditions	Description
Transmission speed	<p>The maximum transmission distance in each segment is the same as that in normal CC-Link system (system configured with one segment only).</p> <p>The maximum transmission distance in each segment varies according to the transmission speed.</p> <p>For details, refer to the User's Manual of the applicable master module.</p> <p>(The length of the cables between repeater stations is treated in the same manner as in the remote I/O station.)</p>
Max. number of stages connected to configure segment	<p>When one connection stage is added, the maximum transmission distance is added by an amount equivalent to one segment.</p>

4. PROCEDURE UP TO START OF DATA LINK

4.1 Procedure up to start of data link

The procedure ranging from the installation of the AJ65SBT-RPS/RPG module to the start of data link is described below.

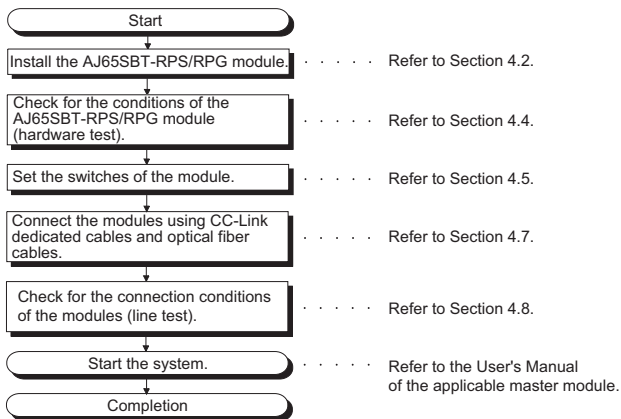

POINT

The procedure described here is for the AJ65SBT-RPS/RPG module only. In order for you to understand the procedure of the entire CC-Link system, refer to the User's Manual of the applicable master module.

4.2 Mounting and installation

4.2.1 Cautions on handling

Cautions on handling the AJ65SBT-RPS/RPG module are described below.

- (1) Tighten screws (such as a module fixing screw) within the tightening torque range specified in the table below.
Do not over-tighten these screws. The screws and module case may be damaged.

Screw location	Specified torque range
Module fixing screw (M4 thread with finished circular flat washer)	0.78 to 1.08 N · m
Terminal block screw (M3 thread) <i>Vis de plaque à bornes (filetage M3)</i>	0.59 to 0.88 N · m <i>0,59 à 0,88 N · m</i>
Terminal block mounting screw (M3.5 thread)	0.68 to 0.98 N · m

- (2) A protective film is attached on the module's surface for the purpose of scratch prevention during transportation.
Prior to use, be sure to remove it.
- (3) When a DIN rail is used, install it taking care with the following.
 - (a) Applicable DIN rail type (conforming to IEC 60715)
TH35-7.5Fe
TH35-7.5A1
 - (b) Intervals of DIN rail mounting screws
Mount the DIN rail by fixing it with mounting screws at intervals of 200 mm (7.87inch) or shorter.
- (4) To install the AJ65SBT-RPS/RPG module on the DIN rail, press, by the finger, the DIN rail hook located on the underside of the module at the centerline until you hear it clicks.

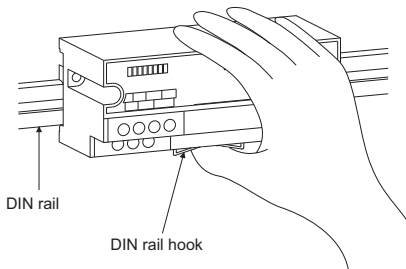

- (5) When installing the AJ65SBT-RPS/RPG module on the control panel, to improve the ventilation and facilitate the replacement of the module, provide a distance of 60 mm (2.36inch) or longer between the upper and lower surfaces of the module and the structural members or parts.
- (6) Install the AJ65SBT-RPS/RPG module on a flat smooth surface. If there are irregularities on the installation surface, undue force may be applied to the printed circuit boards, and the boards may be damaged.
- (7) Depending on the grounding condition of the system, a high-frequency noise may occur between the systems. When these systems are connected through CC-Link dedicated cables, a communication error may occur by the mixing of noise into the repeaters.

If the high-frequency noise occurs between the systems connected through the cables of 10 m (32.79ft.) or shorter, take the measure which uses CC-Link cables of 10 m (32.79ft.) or longer between the systems.

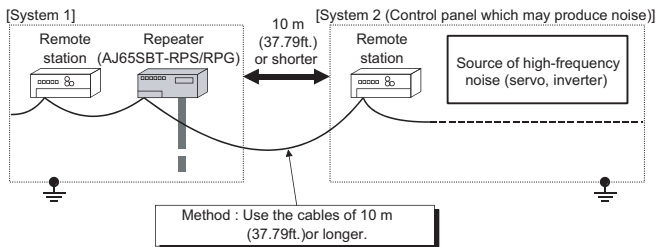

4.2.2 Installation environment

For the installation environment, refer to section 3.1.

4.3 Names and settings of parts

The names of parts of the AJ65SBT-RPS/RPG module, indication statuses of LEDs, and settings of switches are described below. The following shows the AJ65SBT-RPS. The LED indications and switch settings are the same as those for the AJ65SBT-RPG.

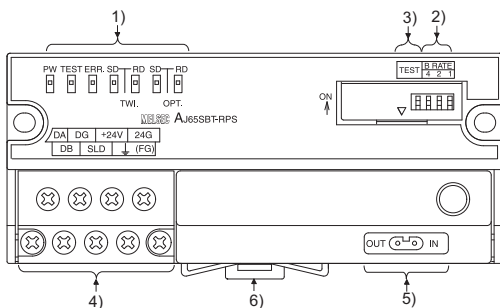

No.	Name	Application				
1)	Power LED	Check for the module condition by observing the state of lighting of the LED.				
		LED Name	Application			
			For hardware test	For normal operation		
		PW	Goes on: At power-on. Goes off: At power-off.			
		TEST	Goes on: Hardware test is under operation. Goes off: Communication is under operation.			
		ERR.	Goes on: Hardware is faulty. Switch set value is faulty. Flashes: Switch set value was changed during operation. Goes off: Normal	Goes on: Communication is faulty. Switch set value is faulty. Flashes: Switch set value was changed during operation. Goes off: Communication is normal.		
		SD1	Flashes: Circuit is normal. Goes off: Circuit is faulty.	Goes on: Data is being transmitted to CC-Link side. Goes off: Data is not transmitted to CC-Link side.		
		RD1	Flashes: CC-Link side circuit is normal. Goes off: Optical communication side circuit is faulty.	Goes on: Data is being received from CC-Link side. Goes off: Data is not received from CC-Link side.		
		SD2	Flashes: Circuit is normal. Goes off: Circuit is faulty.	Goes on: Data is being transmitted to optical communication side. Goes off: Data is not transmitted to optical communication side.		
		RD2	Flashes: CC-Link side circuit is normal. Goes off: Optical communication side circuit is faulty.	Goes on: Data is being received from optical communication side. Goes off: Data is not received from optical communication side.		
2)	Transmission speed setting switch	Set the transmission speed of the module (set to 0 at the time of delivery).				
		Setting value	Setting switch status			Transmission speed
			4	2	1	
		0	OFF	OFF	OFF	156kbps
		1	OFF	OFF	ON	625kbps
		2	OFF	ON	OFF	2.5Mbps
		3	OFF	ON	ON	5Mbps
4	ON	OFF	OFF	10Mbps		
5 to 7	Cannot be set. If set to 5 to 7, the ERR. LED is turned on and data are not transferred.					

No.	Name	Application	
3)	Test switch	Set the operating condition of the module (set to OFF at the time of delivery).	
		State of switch	Operating state
		ON	Hardware test
		OFF	Normal operation
4)	Terminal block	Terminal block for connecting the power supply and CC-Link dedicated cables.	
5)	Optical interface	Terminal block for connecting the CC-Link dedicated cable on the side where the master station is not located.	
6)	Hook for DIN rail	Hook for installing the module on the DIN rail. To install the module, press the DIN rail hook at the centerline until you hear it click.	

POINT

The setting of the test switch is made valid when the module power is turned from OFF to ON. If the setting is changed with the module power ON, perform the above operation again.

4.4 Check of module state (Hardware test)

Check that the module operates normally using the module proper. Ensure to perform this check before configuring the system. A hardware test requires the following type of testing optical cable. Obtain this optional testing optical cable from your nearest Mitsubishi representative.

Item	Type	Description	Remarks
Testing optical cable	AN-CCLT	Optical cable for loopback self-test for CC-Link system optical repeater module (0.5m (1.64ft.))	Optional

Perform the test in accordance with the steps shown below.

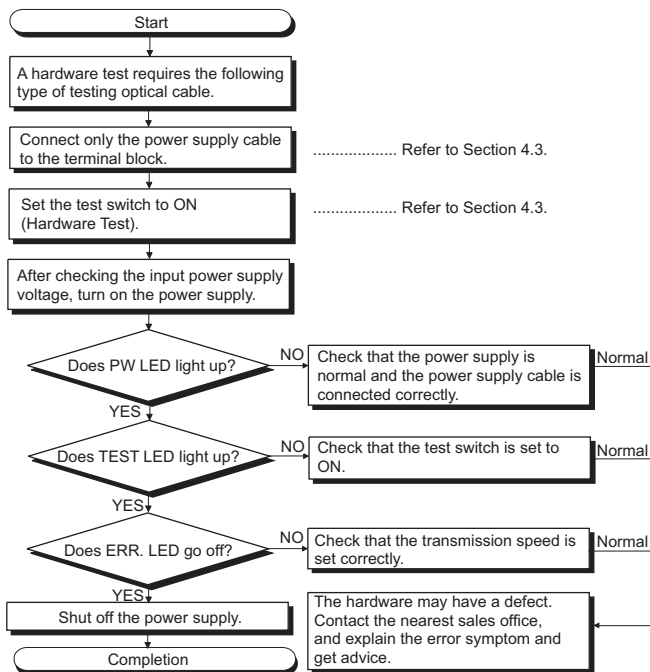

4.5 Setting of switches

The setting of the switches on the AJ65SBT-RPS/RPG module is described below.

(1) Test switch

This switch is used to set the operating condition of the AJ65SBT-RPS/RPG module.

In normal operation, set it to OFF.

For detail of the setting, refer to Section 4.3.

POINT

The setting of the test switch is made valid when the module power is turned from OFF to ON.
--

If the setting is changed with the module power ON, perform the above operation again.
--

(2) Transmission speed setting switch

This switch is used to set the transmission speed of the AJ65SBT-RPS/RPG module.

For detail of the setting, refer to Section 4.3.

POINT

- | |
|---|
| <ul style="list-style-type: none">• Set to the same state of setting as set in the master station.• The setting of the transmission speed setting switches is made valid when the module power is turned from OFF to ON. |
|---|

If the setting is changed with the module power ON, perform the above operation again.
--

4.6 Installation and removal of protective cover

A protective cover can be installed on the front surface of the AJ65SBT-RPS/RPG module to prevent foreign matter from entering the terminal blocks.

The protective cover applicable to the AJ65SBT-RPS/RPG module is specified below.

Procure it as necessary.

Item	Type	Description	Remarks
Protective cover	A6CVR-8	Cover for prevention of entry of foreign matter into terminal blocks (sold in batches of 10).	Optional

To dismount and mount the protective cover on and from the AJ65SBT-RPS/RPG module, follow the steps below.

(1) Mounting

With the upper section of the protective cover hooked to the upper end section of the module, press the lower section of the cover until you hear it click.

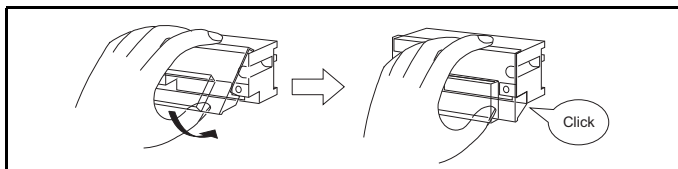

(2) Dismounting

With the finger applied to the lower section of the protective cover, raise the cover upward.

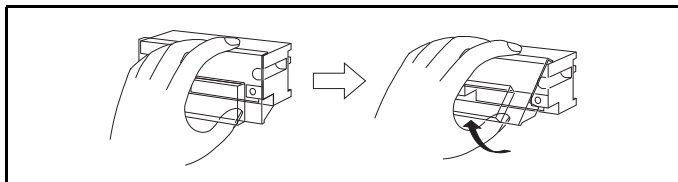

4.7 Connection of module through cable

Raccordement du câble de traversée de module

The method of connecting the AJ65SBT-RPS/RPG module to the CC-Link system through the cable is shown below.

La méthode de connexion d'un module AJ65SBT-RPS/RPG à un système CC-Link par câbles est représentée schématiquement ci-après.

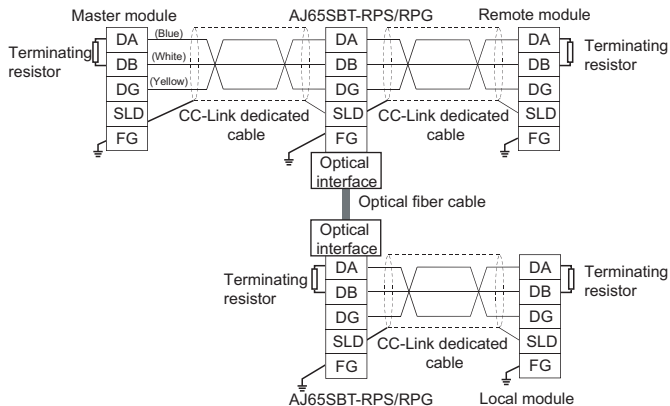

English	French
Master module	Module maître
Remote module	Module distant
Terminating resistor	Résistance d'extrémité
Blue	bleu
White	blanc
Yellow	jaune
CC-Link dedicated cable	Câble dédié pour CC-Link
Optical interface	Interface optique
Optical fiber cable	Câble à fibre optique
Local module	Module local

Important

In each segment, ensure to use the same type of CC-Link dedicated cables. If different types of cables are used, normal data transmission will not be assured.

Sur chaque segment, s'assurer qu'on utilise des câbles dédiés CC-Link du même type.

Si les câbles utilisés sont de types différents, la transmission normale des données ne peut être garantie.

POINT

- Ensure to connect the terminating resistor to both end modules of each segment.
In addition, connect them between DA and.
(The terminating resistor are furnished with the module.)
- The terminating resistor vary according to the type of cables in use.
For detail, refer to the User's Manual of the applicable master module.
- Connect the shielded wire of the CC-Link dedicated cable to "SLD" of each module, and ground both ends of the shielded wire via "FG".
The SLD and FG are connected within the module.
- *Ne pas oublier de raccorder les résistances terminales aux deux modules d'extrémité sur chaque tronçon.*
De plus, établir la connexion entre DA et.
(La résistance terminale est fournie avec le module.)
- *La résistance terminale à utiliser dépend du type des câbles.*
Pour le détail, voir le Manuel de l'utilisateur du module maître concerné.
- *Raccorder le fil de blindage de blindage du câble dédié CC-Link sur "SLD" de chaque module, et mettre à la terre les deux extrémités via "FG".*
SLD et FG sont connectés à l'intérieur du module.

4.8 Check for state of connection (Line test)

Connect all modules including the AJ65SBT-RPS/RPG module through the CC-Link dedicated cable. Then, check that the CC-Link system is in the state capable of performing a data link normally.

Because whether or not a master station can establish a data link with a particular slave station can be checked by the connection status check (circuit test), an error module can be identified.

For the connection status check (circuit test), perform the circuit test 1 of the master module. If an error is detected, perform the circuit test 2 of the master module.

For the details of circuit tests 1 and 2, refer to the user's manual of the master module used.

Perform the test following the steps on the next page.

POINT
Perform the circuit test 2 of the master module by selecting the target stations as described in (1) to (3) below. (1) In the segment including the master module, select slave stations in order from the nearest to the master module to the farthest. (2) In the segment (1st stage), select slave stations in order from the nearest to the AJ65SBT-RPS/RPG to the farthest. (3) In the segment (2nd stage), select slave stations in order from the nearest to the AJ65SBT-RPS/RPG to the farthest.

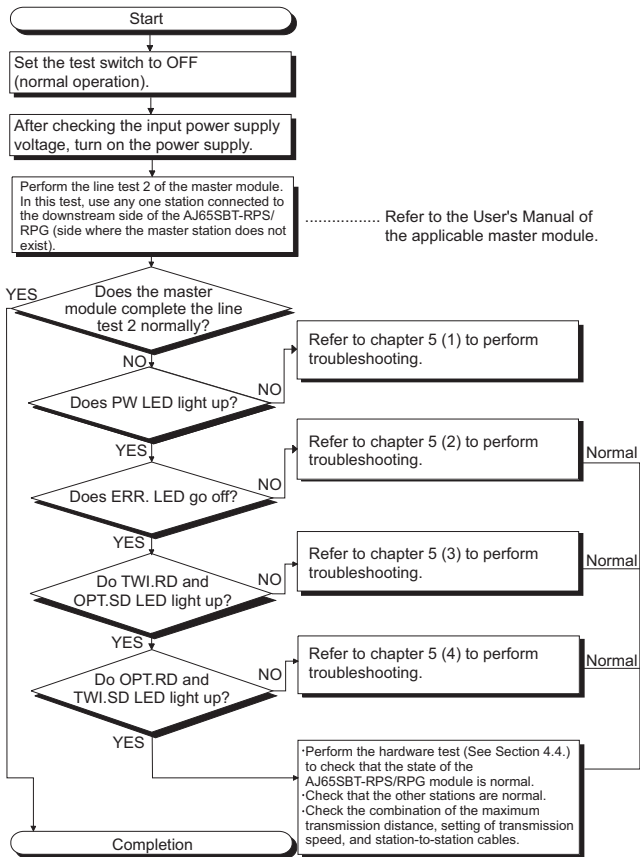

5. TROUBLESHOOTING

This section describes the measures when a trouble occurred in the AJ65SBT-RPS/RPG.

Perform the troubleshooting indicated in the reference section.

This chapter (3), (4) are based on Fig. 5.1.

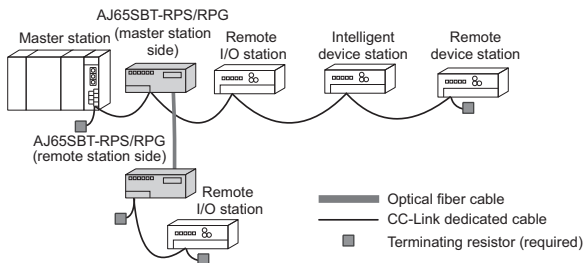
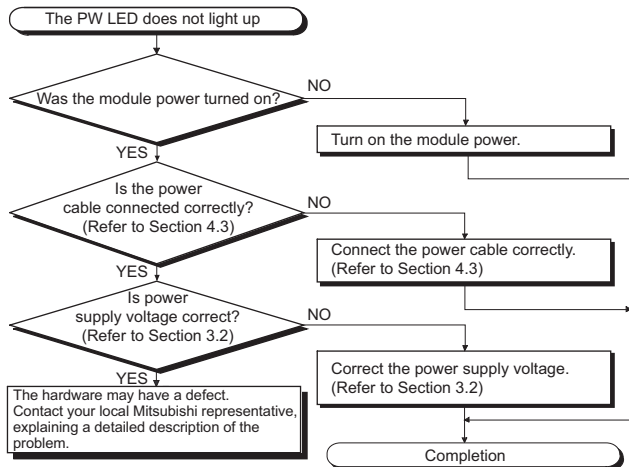

Figure 5.1

No. *1	Problem	Reference section
1	The PW LED is not lit while the module power is ON.	(1) in this chapter
2	The ERR. LED lighted up or blinked.	(2) in this chapter
3	The TWI.RD or OPT.SD LED on the master station side is not lit during data link.	(3) in this chapter
4	The OPT.RD or TWI.SD LED on the master station side is not lit during data link.	(4) in this chapter

*1 If more than one problem occurred simultaneously, perform the troubleshooting in order of the item numbers.

- (1) The PW LED is not lit while the module power is ON
Troubleshooting is shown below for the case that the PW LED is not lit while the module power is ON.



- (2) The ERR. LED lights up or blinks
Troubleshooting is shown below for the case that the ERR. LED lights up or blinks.

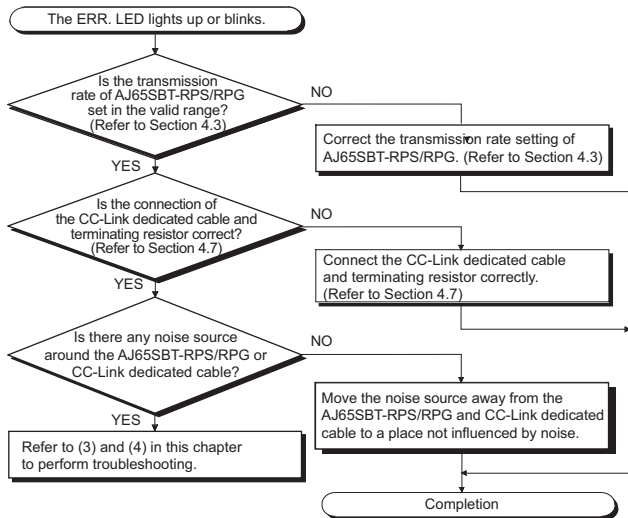

- (3) The TWI.RD or OPT.SD LED on the master station side is not lit during data link

The following shows the troubleshooting process for the case where the TWI.RD or OPT.SD LED on the master station side is not lit during data link.

The descriptions are based on Fig. 5.1.

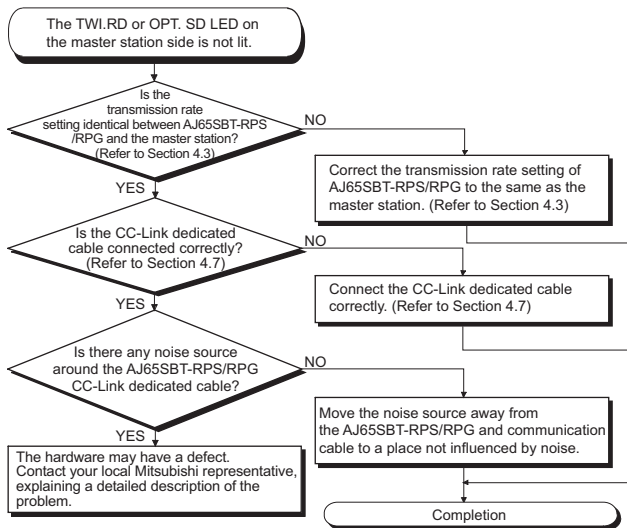

- (4) The OPT.RD or TWI.SD LED on the master station side is not lit during data link

The following shows the troubleshooting process for the case where the OPT.RD or TWI.SD LED on the master station side is not lit during data link.

The descriptions are based on Fig. 5.1.

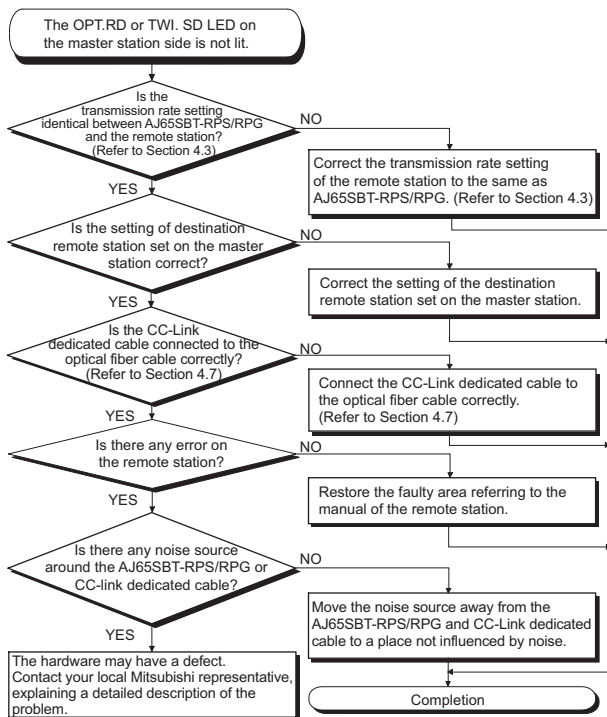

- (2) The hardware version is C or earlier, or the serial number (first five digits) is "16031" or earlier.
 The following is the AJ65SBT-RPS. The same dimensions apply to the AJ65SBT-RPG.

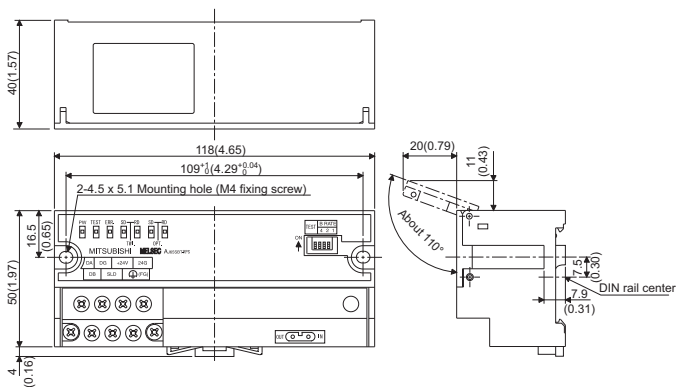

Unit:mm (inch)

WARRANTY

Mitsubishi will not be held liable for damage caused by factors found not to be the cause of Mitsubishi; machine damage or lost profits caused by faults in the Mitsubishi products; damage, secondary damage, accident compensation caused by special factors unpredictable by Mitsubishi; damages to products other than Mitsubishi products; and to other duties.

Country/ Region	Sales office/ Tel	Country/ Region	Sales office/ Tel
USA	MITSUBISHI ELECTRIC AUTOMATION, INC. 500 Corporate Woods Parkway, Vernon Hills, IL 60061, U.S.A. Tel : +1-847-478-2100	Turkey	MITSUBISHI ELECTRIC TURKEY A.Ş. Ümraniye Branch Serifali Mahallesi Nutuk Sokak No.5, TR-34775 Ümraniye/Istanbul, Turkey Tel : +90-216-526-3990
Mexico	MITSUBISHI ELECTRIC AUTOMATION, INC. Mexico Branch Mariano Escobedo #69, Col. Zona Industrial, Tlalneapantla Edo. Mexico, C.P.54030 Tel : +52-55-3067-7500	UAE	MITSUBISHI ELECTRIC EUROPE B.V. Dubai Branch Dubai Silicon Oasis, P.O.BOX 341241, Dubai, U.A.E. Tel : +971-4-3724716
Brazil	MITSUBISHI ELECTRIC DO BRASIL COMÉRCIO E SERVIÇOS LTDA. Avenida Adelino Cardana, 293, 21 andar, Bethaville, Barueri SP, Brazil Tel : +55-11-4689-3000	South Africa	ADROIT TECHNOLOGIES 20 Waterford Office Park, 189 Witkoppen Road, Fourways, South Africa Tel : +27-11-658-8100
Germany	MITSUBISHI ELECTRIC EUROPE B.V. German Branch Mitsubishi-Electric-Platz 1, 40882 Ratingen, Germany Tel : +49-2102-486-0	China	MITSUBISHI ELECTRIC AUTOMATION (CHINA) LTD No.1386 Honggiao Road, Mitsubishi Electric Automation Center, Shanghai, China Tel : +86-21-2322-3030
UK	MITSUBISHI ELECTRIC EUROPE B.V. UK Branch Travellers Lane, Hatfield, Hertfordshire, AL10 8XB, U.K. Tel : +44-1707-28-8780	Taiwan	SETSUYO ENTERPRISE CO., LTD. 6F, No.105, Wugong 3rd Road, Wugu District, New Taipei City 24889, Taiwan Tel : +886-2-2299-2499
Ireland	MITSUBISHI ELECTRIC EUROPE B.V. Irish Branch Westgate Business Park, Ballymount, Dublin 24, Ireland Tel : +353-1-4198800	Korea	MITSUBISHI ELECTRIC AUTOMATION KOREA CO., LTD. 7F-9F, Gangseo Hangang Xi-tower A, 401, Yangcheon-ro, Gangseo-Gu, Seoul 07528, Korea Tel : +82-2-3660-9530
Italy	MITSUBISHI ELECTRIC EUROPE B.V. Italian Branch Centro Direzionale Colleoni-Palazzo Sirio Viale Colleoni 7, 20864 Agrate Brianza(Milano) Italy Tel : +39-039-60531	Singapore	MITSUBISHI ELECTRIC ASIA PTE. LTD. 307, Alexandra Road, Mitsubishi Electric Building, Singapore 159943 Tel : +65-6473-2308
Spain	MITSUBISHI ELECTRIC EUROPE, B.V. Spanish Branch Carretera de Rubí, 76-80-Appdo. 420, 08190 Sant Cugat del Vallés (Barcelona), Spain Tel : +34-935-65-3131	Thailand	MITSUBISHI ELECTRIC FACTORY AUTOMATION (THAILAND) CO., LTD. 12th Floor, SV City Building, Office Tower 1, No. 896/19 and 20 Rama 3 Road, Kwaeng Bangpangpang, Khet Yannawa, Bangkok 10120, Thailand Tel : +66-2682-6522
France	MITSUBISHI ELECTRIC EUROPE B.V. French Branch 25, Boulevard des Bouvets, 92741 Nanterre Cedex, France Tel : +33-1-55-68-55-68	Vietnam	MITSUBISHI ELECTRIC VIETNAM COMPANY LIMITED Hanoi Branch 6th Floor, Detech Tower, 8 Ton That Thuyet Street, My Dinh 2 Ward, Nam Tu Liem District, Hanoi, Vietnam Tel : +84-4-3937-8075
Czech Republic	MITSUBISHI ELECTRIC EUROPE B.V. Czech Branch Avenir Business Park, Radlicka 751/113e, 158 00 Praha5, Czech Republic Tel : +420-251-551-470	Indonesia	PT. MITSUBISHI ELECTRIC INDONESIA Gedung Jaya 11th Floor, J.L. MH. Thamrin No.12, Jakarta Pusat 10340, Indonesia Tel : +62-21-3192-6461
Poland	MITSUBISHI ELECTRIC EUROPE B.V. Polish Branch ul. Krakowska 50, 32-083 Balice, Poland Tel : +48-12-347-65-00	India	MITSUBISHI ELECTRIC INDIA PVT. LTD. Pune Branch Emerald House, EL-3, J Block, M.I.D.C., Bhosari, Pune-411026, Maharashtra, India Tel : +91-20-2710-2000
Sweden	MITSUBISHI ELECTRIC EUROPE B.V. (Scandinavia) Fjellvägen 8, SE-22736 Lund, Sweden Tel : +46-8-625-10-00	Australia	MITSUBISHI ELECTRIC AUSTRALIA PTY. LTD. 348 Victoria Road, P.O. Box 11, Rydalmere, N.S.W 2116, Australia Tel : +61-2-9684-7777
Russia	MITSUBISHI ELECTRIC (RUSSIA) LLC St. Petersburg Branch Piskarevsky pr. 2, bld 2, lit "Sch", BC "Benua", office 720, 195027 St. Petersburg, Russia Tel : +7-812-633-3497		

MITSUBISHI ELECTRIC CORPORATION

HEAD OFFICE : TOKYO BUILDING, 2-7-3 MARUNOUCHI, CHIYODA-KU, TOKYO 100-8310, JAPAN
NAGOYA WORKS : 1-14, YADA-MINAMI 5-CHOME, HIGASHI-KU, NAGOYA, JAPAN

When exported from Japan, this manual does not require application to the Ministry of Economy,
Trade and Industry for service transaction permission.

Specifications subject to change without notice.