

## Programmable Controller

# CC-Link IE Field Network Waterproof Remote IO-Link Module User's Manual

---

-NZ2GF12A-60IOLH8

**Powered by**

**BALLUFF**

This product was jointly developed and manufactured by Mitsubishi Electric and Balluff GmbH.

\* Note that the warranty on this product differs from that on other programmable controller products.  
(Refer to "WARRANTY" in this manual.)



# COPYRIGHT

This document is protected by the law of copyright, whereby all rights established therein remain with the company Mitsubishi Electric Corporation. Reproduction of this document or parts of this document is only permissible within the limits of the legal determination of Copyright Law. Alteration or abridgement of the document is not permitted without the explicit written approval of the company Mitsubishi Electric Corporation.

## PRECAUTIONS REGARDING WARRANTY AND SPECIFICATIONS

The NZ2GF12A-60IOLH8 was jointly developed and manufactured by Mitsubishi Electric and Balluff GmbH. Note that warranty information and specifications are different from those of other MELSEC products.

- Warranty

Item	NZ2GF12A-60IOLH8	Other programmable controller products (example: MELSEC iQ-R series)
Repair and analysis	n/a <sup>*1</sup>	7 years after production discontinuation

\*1 Please note that repairs and failure analysis are refused due to the structure of this product. Therefore, free replacement is arranged for the failure of our responsibility during the warranty period.

- General specifications

Item	NZ2GF12A-60IOLH8	Other programmable controller products (example: MELSEC iQ-R series)
Operating ambient temperature	0 to 55°C (0 to 40°C for UL listed)	0 to 55°C (0 to 60°C when using an extended temperature range base unit)
Equipment class	Class III	Class I

# SAFETY PRECAUTIONS

---

(Read these precautions before using this product.)

Before using this product, please read this manual and the relevant manuals carefully and pay full attention to safety to handle the product correctly.

The precautions given in this manual are concerned with this product only. For the safety precautions of the programmable controller system, refer to the user's manual for the CPU module used.

In this manual, the safety precautions are classified into two levels: "⚠️ WARNING" and "⚠️ CAUTION".

---

## **WARNING**

Indicates that incorrect handling may cause hazardous conditions, resulting in death or severe injury.

---

## **CAUTION**

Indicates that incorrect handling may cause hazardous conditions, resulting in minor or moderate injury or property damage.

---

Under some circumstances, failure to observe the precautions given under "⚠️ CAUTION" may lead to serious consequences.

Observe the precautions of both levels because they are important for personal and system safety.

Make sure that the end users read this manual and then keep the manual in a safe place for future reference.

## [Design Precautions]

---

### **WARNING**

- When a communication failure occurs in the network, data in the master/local module are held. Check Data link status (each station) (SW00B0 to SW00B7) and configure an interlock circuit in the program to ensure that the entire system will operate safely.
  - When the module is disconnected due to a communication failure in the network or the CPU module is in the STOP status, all outputs are held or turned off according to the parameter setting. Configure an interlock circuit in the program to ensure that the entire system will always operate safely even in such a case. Failure to do so may result in an accident due to an incorrect output or malfunction.
  - Outputs may remain on or off due to a failure of the module. Configure an external circuit for monitoring output signals that could cause a serious accident.
  - Do not use any "use prohibited" signals as a remote I/O signal since they are used by the system. Do not write any data to the "use prohibited" areas in the remote register. If these operations are performed, an accident may occur due to an incorrect output or malfunction.
- 

## [Design Precautions]

---

### **CAUTION**

- Do not install the control lines or communication cables together with the main circuit lines or power cables. Keep a distance of 100mm or more between them. Failure to do so may result in malfunction due to noise.
  - During control of an inductive load such as a lamp, heater, or solenoid valve, a large current (approximately ten times greater than normal) may flow when the output is turned from off to on. Therefore, use a module that has a sufficient current rating.
-

## [Security Precautions]

---

### **WARNING**

- To maintain the security (confidentiality, integrity, and availability) of the programmable controller and the system against unauthorized access, denial-of-service (DoS) attacks, computer viruses, and other cyberattacks from external devices via the network, take appropriate measures such as firewalls, virtual private networks (VPNs), and antivirus solutions.
- 

## [Installation Precautions]

---

### **WARNING**

- Shut off the load power supply (all phases) used in the system before mounting or removing a module. Failure to do so may result in electric shock or cause the module to fail or malfunction.
- 

## [Installation Precautions]

---

### **CAUTION**

- Use the module in an environment that meets the general specifications in this manual. Failure to do so may result in electric shock, fire, malfunction, or damage to or deterioration of the product.
  - Do not directly touch any conductive parts and electronic components of the module. Doing so can cause malfunction or failure of the module.
  - Securely fix the module with mounting screws. Otherwise, the module will be greatly affected by vibration, causing failure of the module.
  - Securely connect the cable connectors. Poor contact may cause malfunction.
  - After the first use of the product, do not mount/remove the connector more than 50 times (IEC 61131-2 compliant). Exceeding the limit may cause malfunction.
- 

## [Wiring Precautions]

---

### **WARNING**

- Shut off the load power supply (all phases) used in the system before wiring. Failure to do so may result in electric shock or cause the module to fail or malfunction.
  - In an output circuit, when a load current exceeding the rated current or an overcurrent caused by a load short-circuit flows for a long time, it may cause smoke and fire. To prevent this, configure an external safety circuit, such as a fuse.
-

## [Wiring Precautions]

---

### CAUTION

- Always ground the module using the included FG screw and FG strap. Failure to do so may result in electric shock or malfunction.
  - Check the rated voltage and terminal layout before wiring to the module, and connect the cables correctly. Connecting a power supply with a different voltage rating or incorrect wiring may cause fire or failure.
  - Tighten the waterproof plugs, waterproof caps, and module mounting screws within the specified torque range. Undertightening can cause short circuit, fire, or malfunction. Overtightening can damage the waterproof plug, waterproof cap, and module mounting screw, resulting in short circuit or malfunction.
- 

## [Wiring Precautions]

---

### CAUTION

- The product specifications are satisfied only when all of waterproof plugs and waterproof caps are installed with the recommended connectable devices and all screws are tightened with an appropriate torque.
  - Prevent foreign matter such as dust or wire chips from entering the module. Such foreign matter can cause a fire, failure, or malfunction.
  - Clamp the cables connected to the module. If not, dangling cable may swing or inadvertently be pulled, resulting in damage to the module or cables or malfunction due to poor contact.
  - Do not install the control lines or communication cables together with the main circuit lines or power cables. Keep a distance of 100mm or more between them. Failure to do so may result in malfunction due to noise.
  - When disconnecting the cable from the module, do not pull the cable by the cable part. For the cable with connector, hold the connector part of the cable. Pulling the cable connected to the module may result in malfunction or damage to the module or cable.
  - Wiring and replacement of a module must be performed by qualified maintenance personnel with knowledge of protection against electric shock. For wiring methods, refer to "INSTALLATION AND WIRING" in this manual.
  - Consider fully the operating environment and input response time of CQ and Q terminals because the module may take in noise as input when it is used in SIO mode (digital input).
-

## [Startup and Maintenance Precautions]

---

### **WARNING**

- Do not touch any connector while power is on. Doing so will cause electric shock or malfunction.
  - Shut off the load power supply (all phases) used in the system before cleaning the module or retightening screws or connector screws. Failure to do so may cause the module to fail or malfunction.
- 

## [Startup and Maintenance Precautions]

---

### **CAUTION**

- Do not disassemble or modify the modules. Doing so may cause failure, malfunction, injury, or a fire.
  - Do not drop or apply strong shock to the module. Doing so may damage the module.
  - Shut off the load power supply (all phases) used in the system before mounting or removing a module. Failure to do so may result in electric shock or cause the module to fail or malfunction.
  - After the first use of the product, do not mount/remove the connector more than 50 times (IEC 61131-2 compliant). Exceeding the limit may cause malfunction.
  - Before handling the module or connection cables, touch a conducting object such as a grounded metal to discharge the static electricity from the human body. Failure to do so may cause the module to fail or malfunction.
  - Startup and maintenance of a control panel must be performed by qualified maintenance personnel with knowledge of protection against electric shock. Lock the control panel so that only qualified maintenance personnel can operate it.
- 

## [Disposal Precautions]

---

### **CAUTION**

- When disposing of this product, treat it as industrial waste.
-

# CONDITIONS OF USE FOR THE PRODUCT

---

- (1) MELSEC programmable controller ("the PRODUCT") shall be used in conditions;
- i) where any problem, fault or failure occurring in the PRODUCT, if any, shall not lead to any major or serious accident; and
  - ii) where the backup and fail-safe function are systematically or automatically provided outside of the PRODUCT for the case of any problem, fault or failure occurring in the PRODUCT.
- (2) The PRODUCT has been designed and manufactured for the purpose of being used in general industries. MITSUBISHI ELECTRIC SHALL HAVE NO RESPONSIBILITY OR LIABILITY (INCLUDING, BUT NOT LIMITED TO ANY AND ALL RESPONSIBILITY OR LIABILITY BASED ON CONTRACT, WARRANTY, TORT, PRODUCT LIABILITY) FOR ANY INJURY OR DEATH TO PERSONS OR LOSS OR DAMAGE TO PROPERTY CAUSED BY the PRODUCT THAT ARE OPERATED OR USED IN APPLICATION NOT INTENDED OR EXCLUDED BY INSTRUCTIONS, PRECAUTIONS, OR WARNING CONTAINED IN MITSUBISHI ELECTRIC USER'S, INSTRUCTION AND/OR SAFETY MANUALS, TECHNICAL BULLETINS AND GUIDELINES FOR the PRODUCT.
- ("Prohibited Application")
- Prohibited Applications include, but not limited to, the use of the PRODUCT in;
- Nuclear Power Plants and any other power plants operated by Power companies, and/or any other cases in which the public could be affected if any problem or fault occurs in the PRODUCT.
  - Railway companies or Public service purposes, and/or any other cases in which establishment of a special quality assurance system is required by the Purchaser or End User.
  - Aircraft or Aerospace, Medical applications, Train equipment, transport equipment such as Elevator and Escalator, Incineration and Fuel devices, Vehicles, Manned transportation, Equipment for Recreation and Amusement, and Safety devices, handling of Nuclear or Hazardous Materials or Chemicals, Mining and Drilling, and/or other applications where there is a significant risk of injury to the public or property.
- Notwithstanding the above restrictions, Mitsubishi Electric may in its sole discretion, authorize use of the PRODUCT in one or more of the Prohibited Applications, provided that the usage of the PRODUCT is limited only for the specific applications agreed to by Mitsubishi Electric and provided further that no special quality assurance or fail-safe, redundant or other safety features which exceed the general specifications of the PRODUCTS are required. For details, please contact the Mitsubishi Electric representative in your region.
- (3) Mitsubishi Electric shall have no responsibility or liability for any problems involving programmable controller trouble and system trouble caused by DoS attacks, unauthorized access, computer viruses, and other cyberattacks.



# INTRODUCTION

---

Thank you for purchasing the CC-Link IE Field Network waterproof remote IO-Link module (hereafter abbreviated as IO-Link module).

This manual describes the procedures, system configuration, parameter settings, functions, and troubleshooting of the IO-Link module.

Before using this product, please read this manual and the relevant manuals carefully and develop familiarity with the functions and performance of the IO-Link module to handle the product correctly.

When applying the program examples provided in this manual to an actual system, ensure the applicability and confirm that it will not cause system control problems.

Please make sure that the end users read this manual.

## Relevant product

---

NZ2GF12A-60IOLH8



Unless otherwise specified, this manual describes the program examples in which the remote I/O signals and remote registers are assigned for an IO-Link module as follows.

- Remote input signal: RX0 to RX4F
- Remote output signal: RY0 to RY4F
- Remote register: RWr0 to RWr83, RWw0 to RWw83

For the assignment of remote I/O signals and remote registers, refer to the following.

User's manual for the master/local module used

---

# CONTENTS

COPYRIGHT .....	1
PRECAUTIONS REGARDING WARRANTY AND SPECIFICATIONS .....	1
SAFETY PRECAUTIONS .....	2
CONDITIONS OF USE FOR THE PRODUCT .....	6
INTRODUCTION .....	7
RELEVANT MANUALS .....	11
TERMS .....	12
<b>CHAPTER 1 PART NAMES</b> .....	<b>14</b>
<b>CHAPTER 2 SPECIFICATIONS</b> .....	<b>20</b>
2.1 General Specifications .....	20
2.2 Performance Specifications .....	21
2.3 Function List .....	25
<b>CHAPTER 3 PROCEDURES BEFORE OPERATION</b> .....	<b>27</b>
<b>CHAPTER 4 SYSTEM CONFIGURATION</b> .....	<b>29</b>
4.1 Applicable Systems .....	29
4.2 Recommended Connectable Device List .....	31
<b>CHAPTER 5 INSTALLATION AND WIRING</b> .....	<b>33</b>
5.1 Installation Environment and Installation Position .....	33
Installation environment .....	33
Installation position .....	34
Installation direction .....	35
5.2 Installation .....	36
Fixing the IO-Link module .....	36
5.3 Wiring the Power Cable .....	37
5.4 Wiring of Ethernet Cable .....	38
5.5 Wiring the IO-Link Cable .....	41
5.6 Attaching Waterproof Caps .....	43
5.7 Precautions .....	44
<b>CHAPTER 6 Parameter Setting</b> .....	<b>45</b>
6.1 CC-Link IE Field Network Parameter Setting .....	45
Setting via the engineering tool .....	45
6.2 IO-Link Module Parameter Setting .....	47
Setting via the engineering tool .....	47
Setting via a program .....	50
6.3 Changing the IO-Link Module Parameters .....	51
Setting via the engineering tool .....	51
Setting via a program .....	56
6.4 IO-Link Device Parameter Setting .....	57
Setting procedure when FDC and CommDTM are used .....	57
Conversion procedure of IODD .....	59
Creation procedure of FDC project .....	60
Procedure for adding M_CommDTM-IOLink .....	61

Procedure for configuring communication setting with M_CommDTM-IOLink .....	61
Parameter writing procedure to IO-Link device .....	62
<b>CHAPTER 7 FUNCTIONS</b>	<b>63</b>
<b>7.1 IO-Link Master Functions</b> .....	<b>63</b>
IO-Link cyclic transmission function .....	63
IO-Link transient communication function .....	65
IO-Link device setting automatic upload/download function .....	66
IO-Link device validation function .....	69
Disconnection detection function .....	72
Swap function .....	73
<b>7.2 SIO Mode Function</b> .....	<b>75</b>
SIO input function .....	75
SIO output function .....	76
Number of SIO output ON times integration function .....	77
<b>7.3 Power Supply Monitoring Function</b> .....	<b>78</b>
<b>7.4 Short-Circuit Detection Function</b> .....	<b>79</b>
<b>7.5 Initial Operation Setting Function</b> .....	<b>80</b>
<b>7.6 CC-Link IE Field Network Communication Function</b> .....	<b>82</b>
Cyclic transmission .....	82
Transient transmission .....	83
Output HOLD/CLEAR setting function .....	93
CC-Link IE Field Network diagnostics .....	95
<b>CHAPTER 8 MODULE FUNCTION BLOCKS</b>	<b>97</b>
<b>CHAPTER 9 PROGRAMMING</b>	<b>99</b>
<b>9.1 Precautions for Programming</b> .....	<b>99</b>
<b>9.2 Program Example of Setting Parameters Using a Dedicated Instruction</b> .....	<b>101</b>
<b>9.3 Example of Program to Communicate with an IO-Link Device</b> .....	<b>109</b>
<b>CHAPTER 10 MAINTENANCE AND INSPECTION</b>	<b>115</b>
<b>CHAPTER 11 TROUBLESHOOTING</b>	<b>117</b>
<b>11.1 Checking the LEDs</b> .....	<b>117</b>
<b>11.2 Unit Test</b> .....	<b>120</b>
<b>11.3 Checking the Status of IO-Link Devices</b> .....	<b>121</b>
<b>11.4 Troubleshooting for Each Phenomenon</b> .....	<b>122</b>
<b>11.5 Checking for the Error Codes and the Warning Codes</b> .....	<b>124</b>
<b>11.6 List of Error Codes and the Warning Codes</b> .....	<b>126</b>
List of Error Codes and the Warning Codes .....	126
Error Code List (Communication Error) .....	128
<b>APPENDICES</b>	<b>129</b>
<b>Appendix 1 Remote I/O Signals</b> .....	<b>129</b>
List of remote I/O signals .....	129
Details of remote input signals .....	131
Details of remote output signals .....	135
<b>Appendix 2 Remote Registers</b> .....	<b>138</b>
List of remote register .....	138

Details of Remote Registers .....	140
<b>Appendix 3 Processing Time .....</b>	<b>145</b>
<b>Appendix 4 EMC and Low Voltage Directives .....</b>	<b>146</b>
Measures to comply with the EMC Directive .....	146
Requirements to compliance with the Low Voltage Directive .....	149
<b>Appendix 5 How to Check the Version .....</b>	<b>150</b>
<b>Appendix 6 External Dimensions .....</b>	<b>151</b>
<b>Appendix 7 Additional or Changed Functions .....</b>	<b>152</b>
Additional functions .....	152
<b>Appendix 8 WEEE Directive .....</b>	<b>153</b>
Disposal precautions .....	153
Exportation precautions .....	153
 <b>INDEX</b> .....	 <b>154</b>
<hr/>	
REVISIONS .....	156
WARRANTY .....	157
TRADEMARKS .....	158

# RELEVANT MANUALS

Manual name [manual number]	Description	Available form
CC-Link IE Field Network Waterproof Remote IO-Link Module User's Manual [SH-081761ENG] (this manual)	Part names, specifications, procedures before operation, system configuration, installation, wiring, parameter settings, functions, programming, and troubleshooting of the IO-Link module	Print book e-Manual PDF

## Point

e-Manual refers to the Mitsubishi FA electronic book manuals that can be browsed using a dedicated tool.



e-Manual has the following features:

- Required information can be cross-searched in multiple manuals.
- Other manuals can be accessed from the links in the manual.
- The hardware specifications of each part can be found from the product figures.
- Pages that users often browse can be bookmarked.
- Sample programs can be copied to an engineering tool.

# TERMS

Unless otherwise specified, this manual uses the following terms.

Term	Description
CC-Link IE Field Network	A high-speed and large-capacity open field network that is based on Ethernet (1000BASE-T)
CommDTM (Communication DTM)	A software module used to configure the communication setting required for communications between a personal computer and field devices via the IO-Link master.
CPU module	A generic term for the MELSEC iQ-R series CPU module, MELSEC-Q series CPU module, and MELSEC-L series CPU module
Cyclic transmission	A function by which data are periodically exchanged among stations on the same network using link devices (RX, RY, RWw, and RWr)
Data link	A generic term for cyclic transmission and transient transmission
Dedicated instruction	An instruction that simplifies programming for using functions of intelligent function modules
Device DTM	A software module used to configure the parameter settings of field devices or monitor field devices.
Disconnection	A process of stopping data link if a data link error occurs
DTM (Device Type Manager)	A software module used to configure the communication settings, set parameters of field devices, or monitor field devices when an FDT frame application is used.
DTM catalog	By registering the M_CommDTM-IOLink, the communication settings are automatically configured, and the list of available DTMs is displayed.
Engineering tool	Another term for the software package for the MELSEC programmable controllers
FDC	An abbreviation for the MELSOFT FieldDeviceConfigurator
FDT (Field Device Tool)	Software standard specifications for management, maintenance, adjustment, and development of field devices
FDT frame application	A generic term for applications to use a DTM. An FDT frame application complies with the FDT/DTM open standard
Global label	A label that is valid for all the program data when multiple program data are created in the project. The global label has two types: a module specific label (module label), which is generated automatically by GX Works3, and an optional label, which can be created for any specified device.
Intelligent device station	A station that exchanges I/O signals (bit data) and I/O data (word data) with another station by cyclic transmission. This station can perform transient transmission as well. This station responds to a transient transmission request from another station and also issues a transient transmission request to another station.
IO-Link device	An external device that supports IO-Link
IO-Link module	An abbreviation for the CC-Link IE Field Network waterproof remote IO-Link module
IODD (IO-Link Device Description)	This description consists of the XML file containing the IO-Link device information and the image file in the png format. This description is supplied from a manufacturer of an IO-Link device.
IODD DTM Configurator	A software program that operates the IODD file (device description file of IO-Link) as the Device DTM.
ISDU	Data read from or written to parameters of IO-Link devices
Label	A label that represents a device in a given character string
Link device	A device (RX, RY, RWr, or RWw) in a module on CC-Link IE Field Network
Link special register (SW)	Word data that indicates the operating status and data link status of a module on CC-Link IE Field Network
Link special relay (SB)	Bit data that indicates the operating status and data link status of a module on CC-Link IE Field Network
Local station	A station that performs cyclic transmission and transient transmission with the master station and other local stations. The station is controlled by programs in the CPU module or other equivalent modules on the station.
M_CommDTM-IOLink	CommDTM that supports communications with the IO-Link device via the IO-Link module.
Master station	A station that controls the entire network. This station can perform cyclic transmission and transient transmission with all stations. Only one master station can be used in a network.
Master/local module	An abbreviation for the CC-Link IE Field Network master/local module
MELSOFT FieldDeviceConfigurator	Configuration Tool, which is developed by Mitsubishi Electric Corporation. MELSOFT FieldDeviceConfigurator complies with the FDT/DTM open standard and is used for parameter settings, maintenance, and adjustment of field devices as an FDT frame application.
Module label	A label that represents one of memory areas (I/O signals and buffer memory areas) specific to each module in a given character string. For the module used, GX Works3 automatically generates this label, which can be used as a global label.
Remote device station	A station that exchanges I/O signals (bit data) and I/O data (word data) with another station by cyclic transmission. This station responds to a transient transmission request from another station.
Remote I/O station	A station that exchanges I/O signals (bit data) with the master station by cyclic transmission
Remote input (RX)	Bit data input from a slave station to the master station (For some areas in a local station, data are input in the opposite direction.)  User's manual for the master/local module used

Term	Description
Remote output (RY)	Bit data output from the master station to a slave station (For some areas in a local station, data are output in the opposite direction.)  User's manual for the master/local module used
Remote register (RWr)	Word data input from a slave station to the master station (For some areas in a local station, data are input in the opposite direction.)  User's manual for the master/local module used
Remote register (RWw)	Word data output from the master station to a slave station (For some areas in a local station, data are output in the opposite direction.)  User's manual for the master/local module used
Reserved station	A station reserved for future use. This station is not actually connected, but counted as a connected station
RIRD	A generic term for J.RIRD, JP.RIRD, G.RIRD, and GP.RIRD
RIWT	A generic term for J.RIWT, JP.RIWT, G.RIWT, and GP.RIWT
Sink	A direction of a current. The current flows from the outside to an input terminal or output terminal. (Japan/North America)
Slave station	A generic term for stations other than a master station: local station, remote I/O station, remote device station, and intelligent device station
Source	A direction of a current. The current flows from an input terminal or output terminal to the outside. (Europe)
Transient transmission	A function of communication with another station, which is used when requested by a dedicated instruction or an engineering tool

# 1 PART NAMES

## Part names of the IO-Link module

This section describes part names of the IO-Link module.

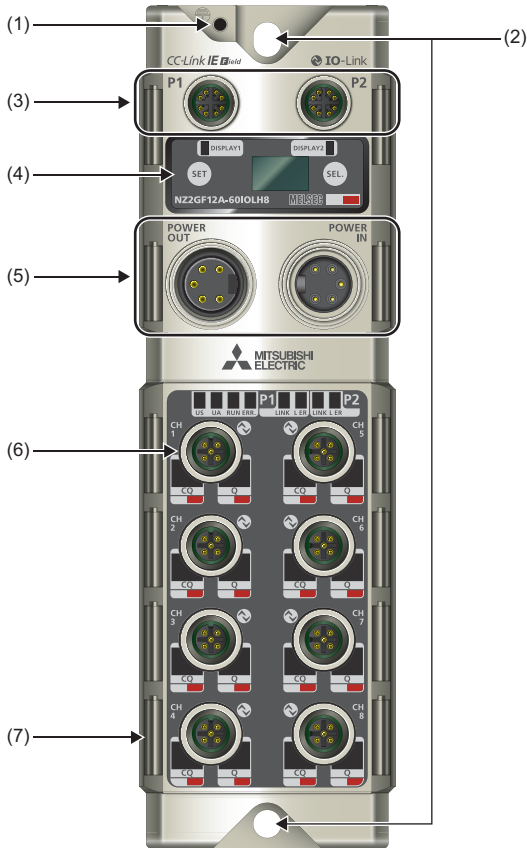

No.	Name	Application	
(1)	FG screw hole	A hole for an FG screw For the tightening torque of FG screws, refer to the following. ☞ Page 36 Installation	
(2)	Module fixing hole	This hole is used to fix the IO-Link module with a module mounting screw. For the tightening torque of module mounting screws, refer to the following. ☞ Page 36 Installation	
(3)	Communication connectors	P1	PORT1 connector for CC-Link IE Field Network Connect an Ethernet cable. (☞ Page 38 Wiring of Ethernet Cable)
		P2	PORT2 connector for CC-Link IE Field Network Connect an Ethernet cable. (☞ Page 38 Wiring of Ethernet Cable)
(4)	Display part	Displays the IO-Link module station number, errors, and other information. Use the [SET] and [SEL.] buttons for operations. (☞ Page 17 Operation specifications of the display part)	
(5)	Power supply connectors	Connectors for the module/sensor power supply (US) (24VDC) and actuator power supply (UA) (24VDC).	
(6)	IO-Link connectors	Connectors for IO-Link communication	
(7)	Signal label fixing part	A ditch to fix supplied signal labels.	



## LED names of the IO-Link module

This section describes the LEDs of the IO-Link module.

1

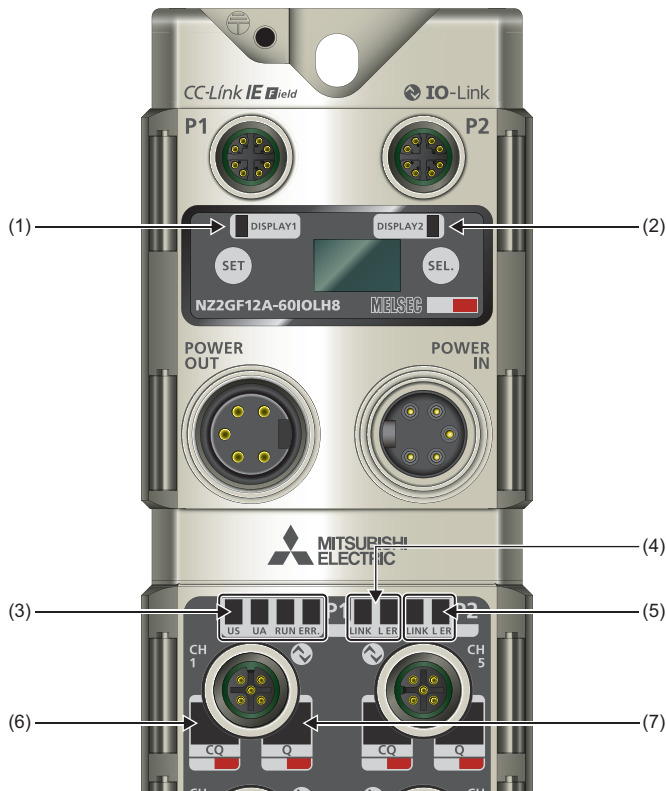

No.	Name	Description
(1)	DISPLAY1 LED	This LED turns on/off when the remote output signal turns on/off.
(2)	DISPLAY2 LED	<p>DISPLAY1 LED and DISPLAY2 LED work in the same way.</p> <p>For example, use a relevant remote output signal in a program so that the sequence processing can be checked via the LED.</p> <p>The LED also shows the result of a unit test.</p> <p>■Remote output signal</p> <p>Green: Display LED1 and LED2 (RY20) are off, and Display LED1 and LED2 (RY21) are on.</p> <p>Red: Display LED1 and LED2 (RY20) are on, and Display LED1 and LED2 (RY21) are off.</p> <p>Orange: Display LED1 and LED2 (RY20) are on, and Display LED1 and LED2 (RY21) are on.</p> <p>Red (flashing): A major error has occurred.</p> <p>Off: Display LED1 and LED2 (RY20) are off, and Display LED1 and LED2 (RY21) are off.</p> <p>■Unit test</p> <p>Green: The unit test result is normal.</p> <p>Red: The unit test result is abnormal.</p>
(3)	US LED	<p>Indicates the voltage status of the module/sensor power supply.</p> <p>Green: The module/sensor power supply has no voltage error.</p> <p>Red: The module/sensor power supply has a voltage error (18VDC or less).</p> <p>Off: The module/sensor power supply is off or has a voltage error (11VDC or less).</p>
	UA LED	<p>Indicates the voltage status of the actuator power supply.</p> <p>Green: The actuator power supply has no voltage error.</p> <p>Red (flashing): The actuator power supply has a voltage error (18VDC or less).</p> <p>Red: The actuator power supply is off or has a voltage error (11VDC or less).</p>
	RUN LED	<p>Indicates the operating status of the IO-Link module.</p> <p>On: Operating normally.</p> <p>Off: A module error has occurred.</p>
	ERR. LED	<p>Indicates the error status of the IO-Link module.</p> <p>On: A module error has occurred.</p> <p>Off: Operating normally.</p>

No.	Name	Description
(4)	LINK LED(P1)	Indicates the link status of the PORT1 connector. On: Linkup in progress Off: Linkdown in progress
	L ER LED(P1)	Indicates the port status of the PORT1 connector. Green: The IO-Link module received normal data. Green (flashing): The network is configured in ring topology without using the loopback function. Red: The IO-Link module received abnormal data. Off: Linkdown in progress
(5)	LINK LED(P2)	Indicates the link status of the PORT2 connector. On: Linkup in progress Off: Linkdown in progress
	L ER LED(P2)	Indicates the port status of the PORT2 connector. Green: The IO-Link module received normal data. Green (flashing): The network is configured in ring topology without using the loopback function. Red: The IO-Link module received abnormal data. Off: Linkdown in progress
(6)	CQ LED	Indicates the operating status of the CQ terminal of each channel. ■In IO-Link mode Green: Operating normally with IO-Link enabled. Green (flashing every 0.5s): Communication is stopped with IO-Link enabled. Green (flashing every 0.3s): Uploading IO-Link device parameters to the data storage, or downloading IO-Link device parameters from the data storage Red (flashing): An error is occurring due to any of the following reasons. <ul style="list-style-type: none"> <li>• The IO-Link device validation setting is enabled, and an IO-Link device is not compatible or identifiable.</li> <li>• The data storage configuration is enabled, and an incompatible IO-Link device is connected.</li> <li>• The configured process data size is smaller than that of the connected IO-Link devices.</li> <li>• The module/sensor power supply (US) voltage is 13V or less.</li> </ul> Off: IO-Link is disabled. ■In SIO mode Orange: I/O is on. Off: I/O is off. Red: An I/O setting error has occurred (short-circuit detection). Red (flashing): An error has occurred (short-circuit detection). <sup>*1</sup>
(7)	Q LED	Indicates the operating status of the Q terminal of each channel. Orange: I/O is on. Off: I/O is off. Red: An I/O setting error has occurred (short-circuit detection). Red (flashing): An error has occurred (short-circuit detection). <sup>*1</sup>

\*1 If both the CQ LED and Q LED flash, a short-circuit has occurred between the L+ and L- terminals.



The US LED, UA LED, LINK LED (P1), L ER LED (P1), LINK LED (P2), and L ER LED (P2) may turn on when the module is powered on. This behavior does not indicate an error.

## Operation specifications of the display part

The display part is used to check information or directly set the station number and network number of the IO-Link module without having to use engineering tools.

When an error occurs, error information is displayed to help users to troubleshoot the module.

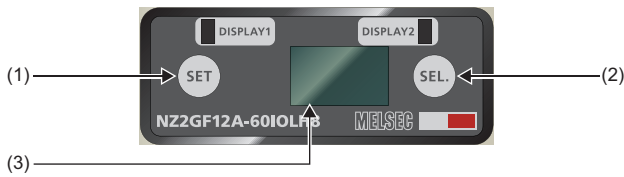

No.	Name	Description
(1)	[SET] button	Used to change the main menu and determine changes of various settings. Press and hold it to activate the Edit mode. In the edit mode, display lock (RY22) can be used to lock any operation. In the locked state, a key icon is displayed on the LCD screen.
(2)	[SEL.] button	Used to change the display for network configuration and module information, and move the cursor between digits of a value.
(3)	LCD screen	Displays information of the IO-Link module. The standby screen (IO-Link module station number) will appear if there is no operation for 10 seconds.

### ■Display at startup

Information is displayed in the following order when the module is powered on.

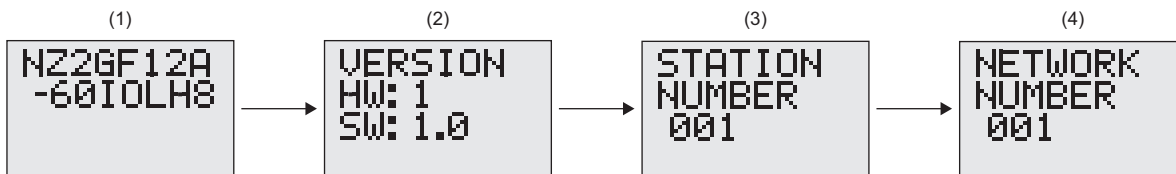

- (1) The model name is displayed.
- (2) The hardware and firmware versions are displayed.
- (3) The station number is displayed.
- (4) The network number is displayed.

### ■Main menu

Window transition of the main menu is as follows. Use the [SET] button to change the main menu.

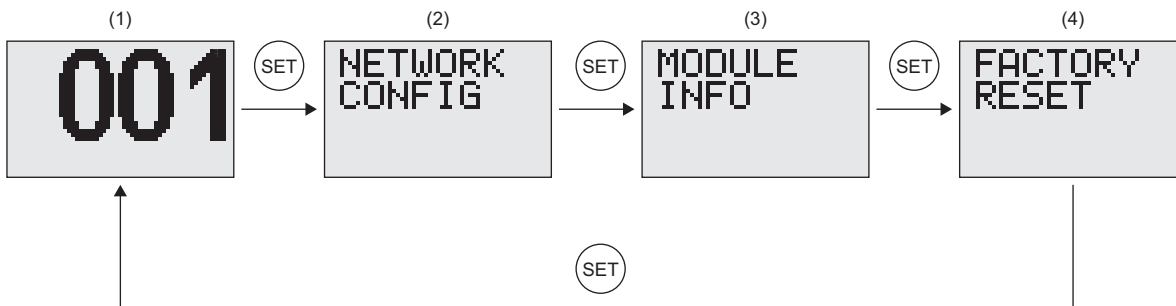

- (1) Standby screen: Displays the station number of the IO-Link module.
- (2) Network configuration window: Used to configure the network.
- (3) Module information window: Used to read information such as errors.
- (4) Initialization window: Used to reset the settings to the factory default values.

## ■ Network configuration

Window transition of the network settings window is as follows. Use the [SEL.] button to change the window.

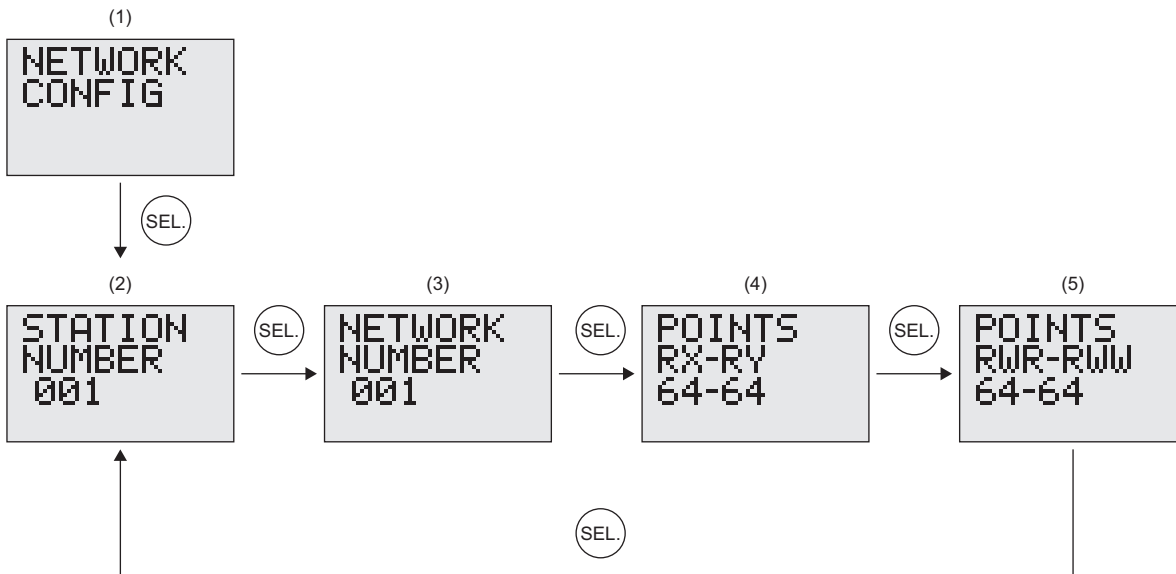

- (1) Press the [SEL.] button on the network configuration window of the main menu
- (2) The station number is displayed.
- (3) The network number is displayed.
- (4) The number of RX/Ry points used is displayed.
- (5) The number of RWR/RWw points used is displayed.

The station number and network number can be changed by pressing and holding the [SET] button on the relevant window.

### Operating procedure

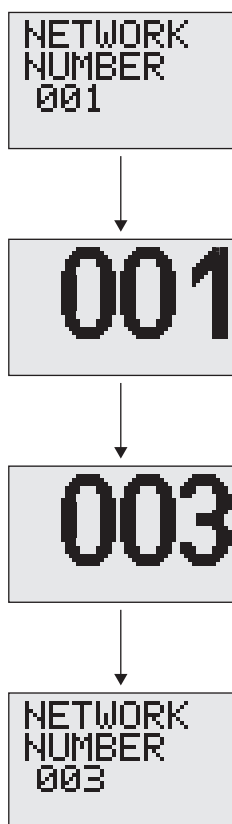

1. Press the [SEL.] button on the network configuration window to display the station number or network number window.
2. Press and hold the [SET] button to enter the edit mode.
3. Press the [SEL.] button to increment the value by one. (Pressing the [SEL.] button at 9 would reset the value to 0.) The cursor to change the digit starts at the far left by default, and pressing the [SET] button changes the cursor location.
4. Press the [SET] button with the cursor located at the far right to save the value and exit the edit mode. At this time, the backlight will flash and ≠ will be displayed on the LCD screen. The changed value will be applied when the IO-Link module is restarted.

## ■Module information

Window transition of the module information is as follows. Use the [SEL.] button to change the display of module information.

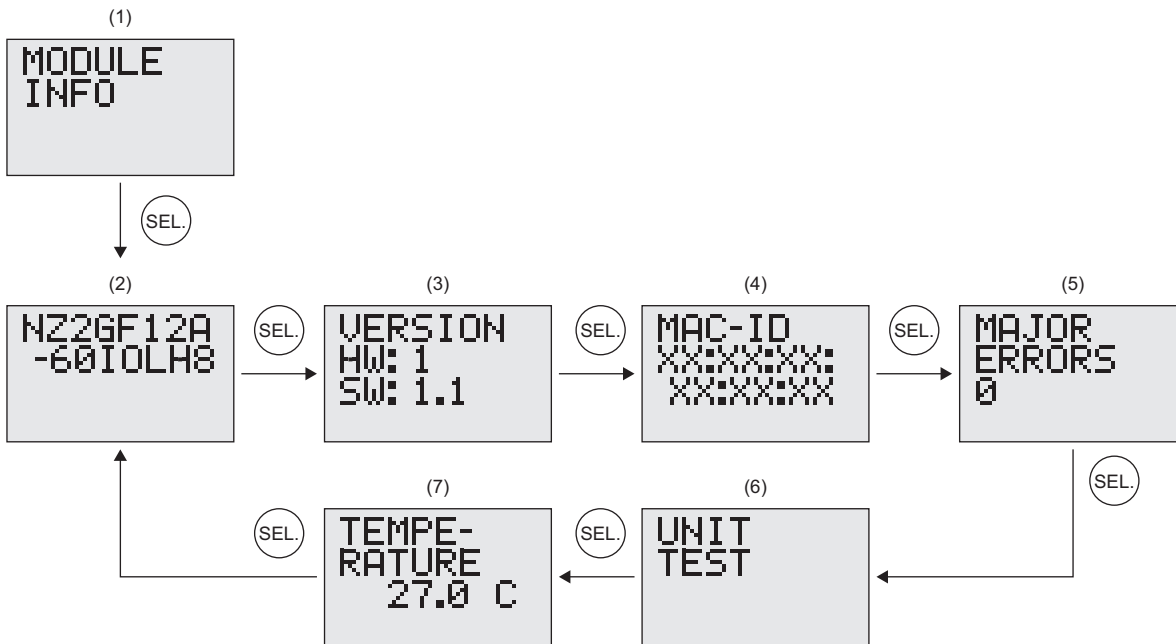

(1) Press the [SEL.] button on the module information window of the main menu.

(2) The model name is displayed.

(3) The hardware and firmware versions are displayed.

(4) The MAC address is displayed.

(5) Major errors can be checked. (☞ Page 125 Checking on the display part)

(6) A unit test can be performed. (☞ Page 120 Unit Test)

(7) The temperature of the IO-Link module is displayed.

## ■Initialization of setting values

Settings such as the station number and network number can be reset to the factory default values.

### Operating procedure

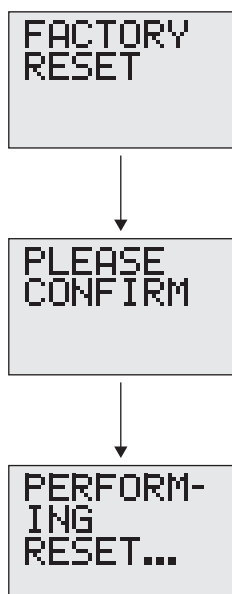

1. Press and hold the [SET] button on the factory reset window to move to the confirmation window.
2. Press the [SET] button again to initialize the settings. To move back to the previous window, press [SEL.] button before pressing the [SET] button.
3. The IO-Link module will automatically restart when the initialization is complete.

# 2 SPECIFICATIONS

This chapter describes the specifications of the IO-Link module.

## 2.1 General Specifications

Item	Specifications					
Operating ambient temperature	0 to 55°C (0 to 40°C for UL listed)					
Storage ambient temperature	-25 to 75°C					
Operating ambient humidity	Conforming to IP67*1					
Storage ambient humidity	5 to 95%RH, non-condensing					
Vibration resistance	Compliant with JIS B 3502 and IEC 61131-2	Under intermittent vibration	Frequency	Constant acceleration	Half amplitude	Number of sweeps
			5 to 8.4Hz	—	3.5mm	X, Y, Z 10 times each in X, Y, and Z directions
		8.4 to 150Hz	9.8m/s <sup>2</sup>	—		
		Under continuous vibration	5 to 8.4Hz	—	1.75mm	—
8.4 to 150Hz	4.9m/s <sup>2</sup>	—				
Shock resistance	Compliant with JIS B 3502 and IEC 61131-2 (147m/s <sup>2</sup> , 3 times each in X, Y, and Z directions)					
Operating atmosphere	No corrosive gases					
Operating altitude*2	0 to 2000m					
Installation location	Inside/outside a control panel					
Overvoltage category*3	II or less					
Pollution degree*4	2 or less					
Equipment class	Class III					

\*1 The product specifications are satisfied only when all of waterproof plugs and waterproof caps are installed with the recommended connectable devices and all screws are tightened with an appropriate torque.

\*2 Do not use or store the IO-Link module under pressure higher than the atmospheric pressure of altitude 0m. Doing so may cause malfunction. When using the IO-Link module under pressure, please consult your local Mitsubishi representative.

\*3 This indicates the section of the power supply to which the equipment is assumed to be connected between the public electrical power distribution network and the machinery within premises.

Category II applies to equipment for which electrical power is supplied from fixed facilities. The surge voltage withstand level for the equipment with the rated voltage of 300V or less is 2500V.

\*4 This index indicates the degree to which conductive material is generated in terms of the environment in which the equipment is used. Pollution degree 2 is when only non-conductive pollution occurs. A temporary conductivity caused by condensing must be expected occasionally.

### Point

To use the IO-Link module complying with the EMC Directive, refer to "EMC and Low Voltage Directives" in this manual. (☞ Page 146 EMC and Low Voltage Directives)

## 2.2 Performance Specifications

### NZ2GF12A-60IOLH8 IO-Link module

Item		NZ2GF12A-60IOLH8
Module type	CC-Link IE Field Network	Intelligent device station
	IO-Link	IO-Link master
Isolation method		Non-isolation
Protection degree		IP67
Wiring method for common		1 common
Surge suppressor		Zener diode
Fuse		Module: Not available Channel: Available
Protection function	Overload protection function	Overcurrent is detectable on the CQ, Q, and L+ terminals on each channel.
External interface	Module power supply part	7/8" waterproof connector, 5 pins, male/female
	I/O part	M12 waterproof connector, 5 pins, female, A-code
	Communication part	M12 waterproof connector, 8 pins, female, X-code
Channel setting		The following 3 modes are available. <ul style="list-style-type: none"> <li>• IO-Link mode</li> <li>• SIO mode (digital input) (default)</li> <li>• SIO mode (digital output)</li> </ul>
IO-Link mode	Supported protocol	v1.12
	Number of channels	8 channels max.
	Max. load current (CQ)	500mA/channel, 9A/common
	Max. load current (L+)	1.3A/channel, 9A/common
	Transmission speed	<ul style="list-style-type: none"> <li>• 4.8kbaud (COM1)</li> <li>• 38.4kbaud (COM2)</li> <li>• 230.4kbaud (COM3)</li> </ul> Determined by the IO-Link device connected.
SIO mode (CQ) (digital input)	Number of points	8 points max.
	Input type	Negative common (source type)
	Rated input current	IEC 61131-2 Type3
	Input resistance	IEC 61131-2 Type3
	ON voltage/ON current	11VDC or more/15mA or more
	OFF voltage/OFF current	5.0VDC or less/1.5mA or less
	Input response time (OFF→ON)	0.1ms or less (excluding the internal processing time)
Input response time (ON→OFF)	0.1ms or less (excluding the internal processing time)	
SIO mode (CQ) (digital output)	Number of points	8 points max.
	Output type	Source type
	Max. load current	2A/point, 9A/common
	Max. inrush current	17A (25°C, 150μs or less)
	Leakage current at OFF	5μA or less
	Max. voltage drop at ON	0.85VDC, 2.0A
	Output response time (OFF→ON)	80μs or less
Output response time (ON→OFF)	150μs or less	

Item		NZ2GF12A-60IOLH8
SIO mode (Q) (digital input)	Number of points	8 points max.
	Input type	Negative common (source type)
	Rated input current	5mA TYP. (for 24VDC)
	Input resistance	4.8kΩ
	ON voltage/ON current	15VDC or more/3.5mA or more
	OFF voltage/OFF current	3.0VDC or less/0.5mA or less
	Input response time (OFF→ON)	1.9ms
	Input response time (ON→OFF)	1.9ms
SIO mode (Q) (digital output)	Number of points	8 points max.
	Output type	Source type
	Max. load current	2A/point, 9A/common
	Max. inrush current	17A (25°C, 150μs or less)
	Leakage current at OFF	5μA or less
	Max. voltage drop at ON	0.85VDC, 2.0A
	Output response time (OFF→ON)	80μs or less
	Output response time (ON→OFF)	105μs or less
Communication cable		An Ethernet cable that meets the 1000BASE-T standard: Category 5e or higher (double shielded, STP), straight cable
IO-Link cable	Cable type	Unshielded
	Cable length	20m max.
	Cable diameter	Core 0.5 to 1.5mm <sup>2</sup>
Module/sensor power supply	Voltage	24VDC (ripple rate: 1% or less) (Allowable voltage range: 20.4 to 28.8VDC) (20.4 to 26.4VDC for UL listed)
	Current* <sup>1</sup>	300mA or less (24VDC, no load) 9.3A or less (24VDC, max. load)
Output power supply	Voltage	24VDC (ripple rate: 1% or less) (Allowable voltage range: 20.4 to 28.8VDC) (20.4 to 26.4VDC for UL listed)
	Current* <sup>1</sup>	9.3A or less (24VDC, max. load)
Weight		0.685kg

\*1 Ensure that the total current capacity of the module/sensor power supply and the output power supply does not exceed 9.3A.  
Ensure that the total current capacity does not exceed 9.3A if transition wiring is used to supply power to multiple modules.  
Ensure that the current capacity of the power supply connector (for module/sensor power supply + actuator power supply) of the first IO-Link module connected to the power supplier does not exceed 9.3A.

### Point

The processing time of the intelligent device station (input) is the time period for internal processing of the intelligent device station (input). The value of the processing time of the intelligent device station (input) is used in the calculation for the delay time of the cyclic transmission from the intelligent device station (input) to the master station (RX/RWr). Calculate the processing time of the intelligent device station (input) by the following formula.

- The processing time of the intelligent device station (input) = The input response time + The internal processing time (0.2ms)

For the delay time of the cyclic transmission from the intelligent device station (input) to the master station (RX/RWr), refer to the following.

 User's manual for the master/local module used



## External connection

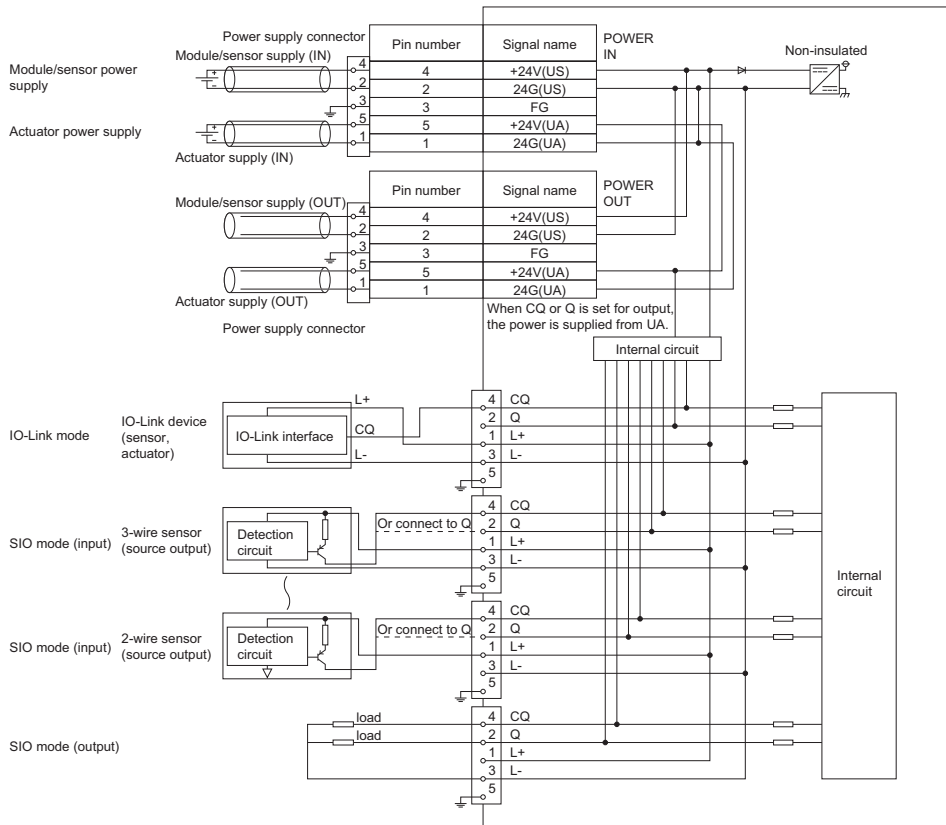

## Power supply connectors

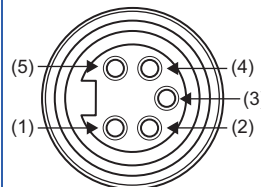
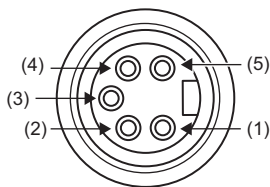

Pin number	Signal name	Pin number	Signal name
POWER OUT	(1) 24G(UA)	POWER IN	(1) 24G(UA)
	(2) 24G(US)		(2) 24G(US)
	(3) FG		(3) FG
	(4) +24V(US)		(4) +24V(US)
	(5) +24V(UA)		(5) +24V(UA)

## IO-Link connectors

[CH1 to CH4]

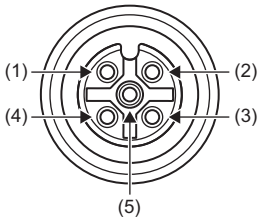

[CH5 to CH8]

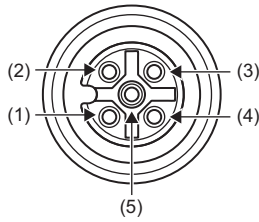

Pin number	Signal name	Pin number	Signal name
CH1	(1) L+	CH5	(1) L+
	(2) Q		(2) Q
	(3) L-		(3) L-
	(4) CQ		(4) CQ
	(5) FG		(5) FG
CH2	(1) L+	CH6	(1) L+
	(2) Q		(2) Q
	(3) L-		(3) L-
	(4) CQ		(4) CQ
	(5) FG		(5) FG
CH3	(1) L+	CH7	(1) L+
	(2) Q		(2) Q
	(3) L-		(3) L-
	(4) CQ		(4) CQ
	(5) FG		(5) FG
CH4	(1) L+	CH8	(1) L+
	(2) Q		(2) Q
	(3) L-		(3) L-
	(4) CQ		(4) CQ
	(5) FG		(5) FG

## Derating chart (input and output)

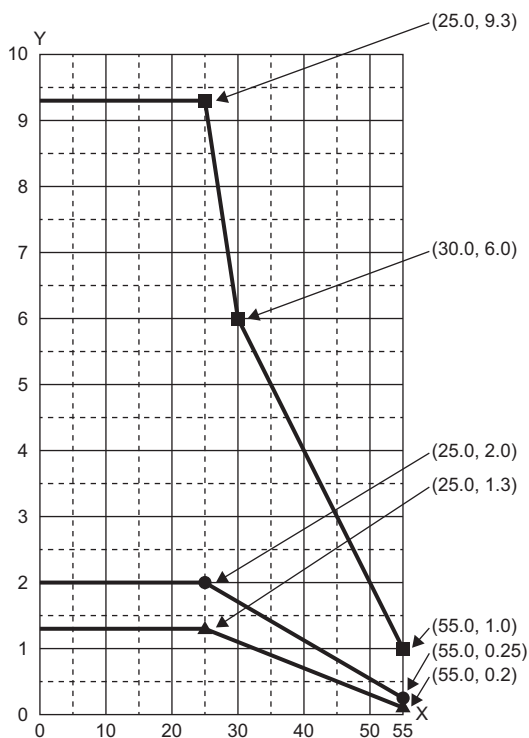

X: Ambient temperature (°C)

Y: Allowable current (A)

●: Allowable current per point on the CQ and Q terminals

▲: Allowable current per channel on the L+ terminal

■: Allowable current per common (UA+US)

## 2.3 Function List

This section lists the functions of IO-Link modules.

### IO-Link master functions

Item	Description	Reference
IO-Link cyclic transmission function	Communicates process data periodically with the IO-Link device connected to each channel.	Page 63 IO-Link cyclic transmission function
IO-Link transient communication function	Reads/writes parameters at any timing from/to the IO-Link device connected to each channel.	Page 65 IO-Link transient communication function
IO-Link device setting automatic upload/download function	Saves the parameter setting of the IO-Link device connected to each channel in the IO-Link module, and as necessary, overwrites the parameter setting of the IO-Link devices. Use this function to inherit parameter setting of an IO-Link device when replacing it.	Page 66 IO-Link device setting automatic upload/download function
IO-Link device validation function	This function validates compatibility and identity of the IO-Link device connected to each channel. An error occurs if an IO-Link device is not compatible or identifiable.	Page 69 IO-Link device validation function
Disconnection detection function	Detects disconnection if communication with an IO-Link device is lost in IO-Link mode.	Page 72 Disconnection detection function
Swap function	Swaps the upper and lower bytes of data sent and received between the IO-Link module and the IO-Link device connected to each channel.	Page 73 Swap function

### SIO mode function

Item	Description	Reference
SIO input function	The ON/OFF status of inputs is notified to Remote input (RX) of the CC-Link IE Field Network.	Page 75 SIO input function
SIO output function	The ON/OFF status of outputs is controlled with Remote output (RY) of the CC-Link IE Field Network master station.	Page 76 SIO output function
Number of SIO output ON times integration function	Counts the number of SIO output ON times of each channel.	Page 77 Number of SIO output ON times integration function

### CC-Link IE Field Network communication function

Item	Description	Reference
Cyclic transmission	Periodically exchanges data among stations on the network using link devices. An IO-Link module operates as an intelligent device station on the CC-Link IE Field Network.	Page 82 Cyclic transmission
Transient transmission	Reads or writes data on the IO-Link module in line with a dedicated instruction from the master station.	Page 83 Transient transmission
Output HOLD/CLEAR setting function	This function sets the handling of the last output data when the IO-Link module is disconnected from data link or when the CPU module is in the STOP state, RESET state, or ERROR STOP state.	Page 93 Output HOLD/CLEAR setting function
CC-Link IE Field Network diagnostics	This function allows the presence or absence of a network error to be checked by accessing the engineering tool connected to the CPU module.	Page 95 CC-Link IE Field Network diagnostics

## RAS

Item	Description	Reference
Power supply monitoring function	Checks the module/sensor power supply (US) voltage and the actuator power supply (UA) voltage, and notifies of the status when voltage drops.	Page 78 Power Supply Monitoring Function
Short-circuit detection function	Detects a short-circuit in each channel to prevent overcurrent or an excessive temperature rise.	Page 79 Short-Circuit Detection Function

## Others

Item	Description	Reference
Initial operation setting function	Sets whether the initial processing using the program is necessary or not when the data link is established.	Page 80 Initial Operation Setting Function

# 3 PROCEDURES BEFORE OPERATION

---

This chapter describes the procedures before operation.

## 1. Installation

Mount the IO-Link module. (☞ Page 33 INSTALLATION AND WIRING)

## 2. Wiring

Wire a power supply, an Ethernet cable, and an external device to the IO-Link module. (☞ Page 33 INSTALLATION AND WIRING)

## 3. Station number setting

Power on the IO-Link module and set the station number. (☞ Page 18 Network configuration)

## 4. CC-Link IE Field Network parameter setting

Connect an engineering tool to the CC-Link IE Field Network master station and configure the CC-Link IE Field Network parameters. (☞ Page 45 CC-Link IE Field Network Parameter Setting)

## 5. IO-Link module parameter setting

Use an engineering tool to configure the IO-Link module parameters. (☞ Page 47 IO-Link Module Parameter Setting)

## 6. Programming

Create a program. (☞ Page 99 PROGRAMMING)

### Point

---

To replace the IO-Link module, follow the procedure described below.

- Turn off the IO-Link module power supply and remove the IO-Link module.
  - Prepare a new IO-Link module and perform the above procedure for wiring, parameter setting, and programming. (The network parameters of the CC-Link IE Field Network master station do not need to be set again.)
  - After checking the operation, restart the control.
-

# MEMO

---

# 4 SYSTEM CONFIGURATION

This chapter describes system configuration using an IO-Link module.

For CC-Link IE Field Network configuration, refer to the following.

 User's manual for the master/local module used

## 4.1 Applicable Systems

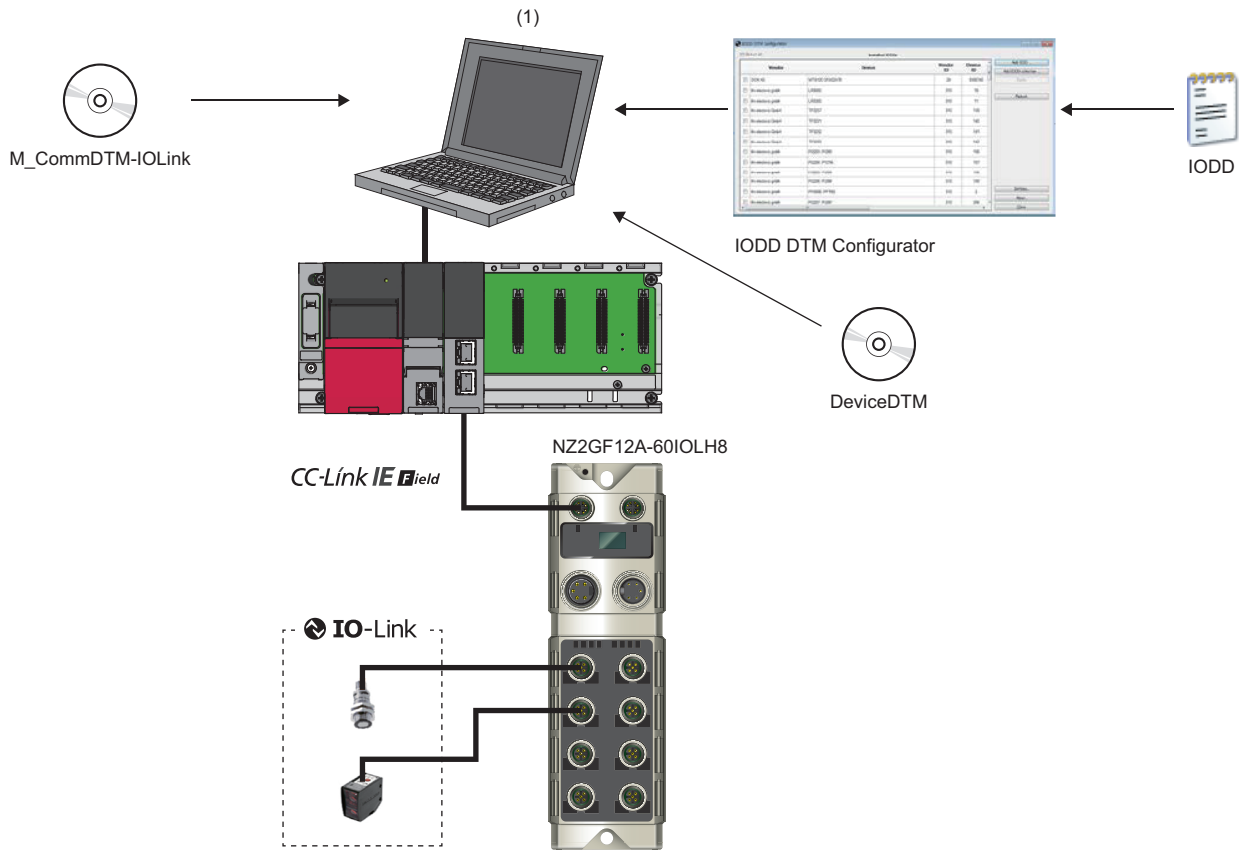

(1) Personal computer (engineering tool/FDC)

### Applicable master station

When using an IO-Link module, use the following products as a master station.

Model*1	First five digits of serial number
RJ71GF11-T2	No restriction
RJ71EN71	
R04ENCPU, R08ENCPU, R16ENCPU, R32ENCPU, R120ENCPU	
QJ71GF11-T2	
LJ71GF11-T2	

\*1 Simple motion modules and interface boards compatible with the CC-Link IE Field Network cannot be used. Information on "Applicable master station" described above is the ones at the point when this manual was issued. For latest information, please visit the website of CC-Link Partner Association. [www.cc-link.org](http://www.cc-link.org)

### Ethernet cable

Use a general-purpose Ethernet cable compliant with 1000BASE-T.

Consider the operating environment when selecting available cables that satisfy the product specifications.

## IO-Link cable

For details on IO-Link cables, refer to the following.

 Page 31 Recommended Connectable Device List

## Available software

The following software is available for settings and diagnostics of the IO-Link module. ( Manuals of each software)

Product name	Function and application
GX Works2	Software for system design, programming, debugging, and maintenance of the programmable controller.
GX Works3	
MELSOFT Navigator	Integrated application of GX Works2 and GX Works3.
FDC	Application for DTM. Only IO-Link modules of which firmware version is 2.0.2 or later are supported.
M_CommDTM-IOLink	
IODD DTM Configurator	

When the latest software is required, please consult your local Mitsubishi representative.

## Applicable profile

To use the parameter setting function of an IO-Link module, the profile is required.

The profile is a setting file that stores information required for the start-up, operation, and maintenance of devices supporting the CC-Link family.

A module is added to "Module List" of "CC IE Field Configuration" window by profile registration to an engineering tool. For the profile registration, refer to the operating manual for the engineering tool used.

## Applicable devices

IO-Link devices and I/O devices incompatible with IO-Link can be connected in combination.

The IO-Link mode and SIO mode can be set separately on the channels of the IO-Link module.

### ■IO-Link mode

If the channels are set in the IO-Link mode, a maximum of eight IO-Link devices can be connected.

IO-Link communication is performed via the CQ terminal of the IO-Link connector.

### ■SIO mode (digital input, digital output)

If the channels are set in the SIO mode, a maximum of 16 signals are available. Each signal can be separately configured for input/output.

Input/output is performed via the CQ and Q terminals of the IO-Link connector.

Both the input type and output type are negative common (source type).

### Point

- To change the operation mode, use the Channel n (CQ/Q) I/O switching command (RY10 to RY1F) and the Channel n mode switching command (RY30 to RY37). ( Page 136 Channel n (CQ/Q) I/O switching command (RY10 to RY1F), Page 137 Channel n mode switching command (RY30 to RY37))
- To use I/O devices not compatible with IO-Link, use the SIO mode.



## 4.2 Recommended Connectable Device List

This section describes devices that can be connected to the IO-Link module.

□ of a model name indicates a numerical value representing the length of each cable.

For details on connectable devices, refer to the Balluff GmbH homepage.

www.balluff.com

### Power Cable

The following table lists the power cables connectable to the power supply connectors.

Model	Connector type	Connector shape	Connection cable diameter
BCC A315-A315-30-335-PX05A5-□ (□ indicates 020, 050, or 100.)	7/8" (male (5 pins)) / 7/8" (female (5 pins))	Straight/straight	φ8.5 to 8.9mm
BCC A315-A325-30-335-PX05A5-□ (□ indicates 020, 050, or 100.)		Angle/straight	
BCC A325-A315-30-335-PX05A5-□ (□ indicates 020, 050, or 100.)		Straight/angle	
BCC A325-A325-30-335-PX05A5-□ (□ indicates 020, 050, or 100.)		Angle/angle	
BCC A315-0000-10-063-PX05A5-□ (□ indicates 020, 050, or 100.)	7/8" (female (5 pins)) (One end connector cable)	Straight	
BCC A325-0000-10-063-PX05A5-□ (□ indicates 020, 050, or 100.)		Angle	

### IO-Link cable

The following table lists the IO-Link cables connectable to the IO-Link connectors.

Model	Connector type	Connector shape	Connection cable diameter
BCC M415-M413-3A-300-PX0334-□ (□ indicates 020, 030, or 050.)	M12 (male (3 pins))/M12 (female (3 pins))	Straight/straight	φ4.1 to 4.5mm
BCC M415-M423-3A-300-PX0334-□ (□ indicates 020, 030, or 050.)		Angle/straight	
BCC M425-M413-3A-300-PX0334-□ (□ indicates 020, 030, or 050.)		Straight/angle	
BCC M425-M423-3A-300-PX0334-□ (□ indicates 020, 030, or 050.)		Angle/angle	
BCC M415-M414-3A-304-PX0434-□ (□ indicates 020, 030, or 050.)	M12 (male (4 pins))/M12 (female (4 pins))	Straight/straight	φ4.5 to 4.9mm
BCC M415-M424-3A-304-PX0434-□ (□ indicates 020, 030, or 050.)		Angle/straight	
BCC M425-M414-3A-304-PX0434-□ (□ indicates 020, 030, or 050.)		Straight/angle	
BCC M425-M424-3A-304-PX0434-□ (□ indicates 020, 030, or 050.)		Angle/angle	
BCC M415-M415-3A-313-PX0534-□ (□ indicates 020, 030, or 050.)	M12 (male (5 pins))/M12 (female (5 pins))	Straight/straight	φ4.8 to 5.2mm
BCC M425-M415-3A-313-PX0534-□ (□ indicates 020, 030, or 050.)		Straight/angle	

## Y-branch connector for I/O

The following table lists applicable Y-branch connectors for I/O.

Model	Connector type	Connector shape	Connection cable diameter
BCC M415-M415-M415-U0003-000	M12 (male (5 pins))/M12 (female (5 pins))/ M12 (female (5 pins))	A code	—

## Waterproof cap

The following table lists applicable waterproof caps.

Model	Connector type	Connector shape	Connection cable diameter
BKS-12-CS-01	M12 (for communication connectors and IO-Link connectors)	—	—
BAM CS-XA-002-M12-A			
BKS-7/8-CS-00-A	7/8" (for connectors for power supply)		
BKS-7/8-CS-00-I			

## Torque wrench

The following table lists the torque wrenches used to connect the Ethernet cable, power cable, and IO-Link cable.

Model	Type	Connector shape	Connection cable diameter
BAM TO-CC-001-M4-0,6/12,0	M12 (for communication connectors and IO-Link connectors)	—	—
BAM TO-CC-001-A3-1,5/24,0	7/8" (for connectors for power supply)		

# 5 INSTALLATION AND WIRING

This chapter describes the installation and wiring of the IO-Link module.

## 5.1 Installation Environment and Installation Position

### Installation environment

#### Installation location

Do not install the IO-Link module to the place under the following condition.

For UL listed products, ensure that the ambient temperature and input voltage satisfy the specifications.

- Ambient temperature is outside the range of 0 to 55°C (0 to 40°C for UL listed products);
- IP67 is not satisfied;
- Condensation occurs due to rapid temperature change;
- Corrosive gas or combustible gas is present;
- Conductive powder such as dust and iron powder, oil mist, salinity, or organic solvent is filled;
- The IO-Link module is exposed to direct sunlight;
- A strong electric field or strong magnetic field is generated; and
- The IO-Link module is subject to vibration and shock.

#### Installation surface

Install the IO-Link module on the flat surface. When the installation surface is uneven, excessive force is applied to the IO-Link module and may cause a defect.

## Installation position

The IO-Link module can be installed without restricting the clearance between the side surface of the module and any structure or part if ventilation and interference measures are sufficient and no load is applied to waterproof connectors.

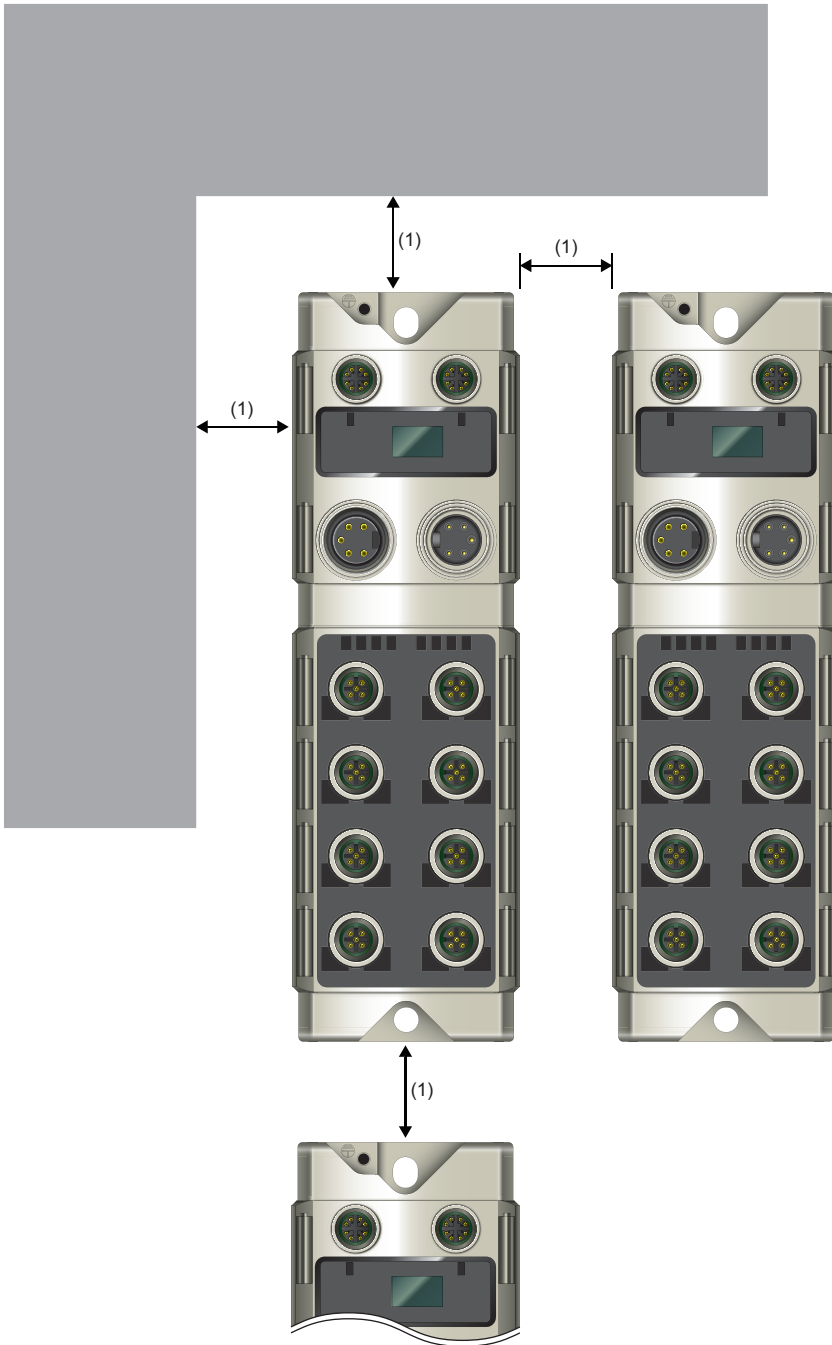

(1) No restrictions

# Installation direction

The IO-Link module can be installed in six directions.  
Fix the module with screws.

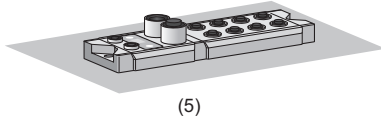
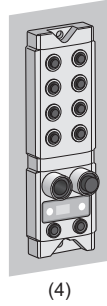
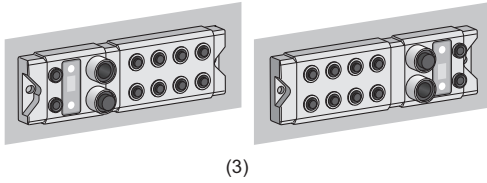
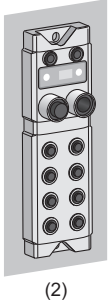
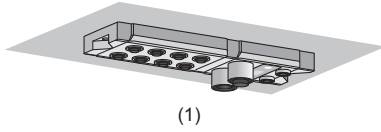

- (1) Downward installation
- (2) Vertical installation
- (3) Horizontal installation
- (4) Vertical installation (upside down)
- (5) Upward installation

## 5.2 Installation

---

### Fixing the IO-Link module

---

When fixing the IO-Link module, tighten all the two screws in the module fixing holes.

Otherwise, the module will be greatly affected by vibration, causing failure of the module.

When installing the module, tighten screws within the following torque range.

Screw type	Tightening torque range
Module mounting screw (M6 screw)	4.90 to 5.20N·m
FG screw (M4 screw)	1.02 to 1.38N·m

---

#### Point

- Do not put oil on the screw. Failure to do so may damage the screw.
  - Tighten the screw with an applicable screwdriver. Tightening it with an inapplicable screwdriver may damage the screw.
-

## 5.3 Wiring the Power Cable

When wiring the power supply, wire the POWER IN terminal and the power supply connector of the IO-Link module. While ensuring that the direction of the power cable connector is correct, insert it into the IO-Link module, and tighten the power cable screw.

### Point

- Attach waterproof caps to connector not used.
- The product specifications are satisfied only when all of waterproof plugs are installed with the recommended connectable devices and all screws are tightened with an appropriate torque. (☞ Page 31 Recommended Connectable Device List)

### Transition wiring of the power supply

When installing multiple IO-Link modules, the power can be supplied to the modules through transition wiring. For transition wiring, connect wires between the POWER OUT terminal of the IO-Link module that will be the power supplier and the POWER IN terminal of another IO-Link module that will be a power supply destination.

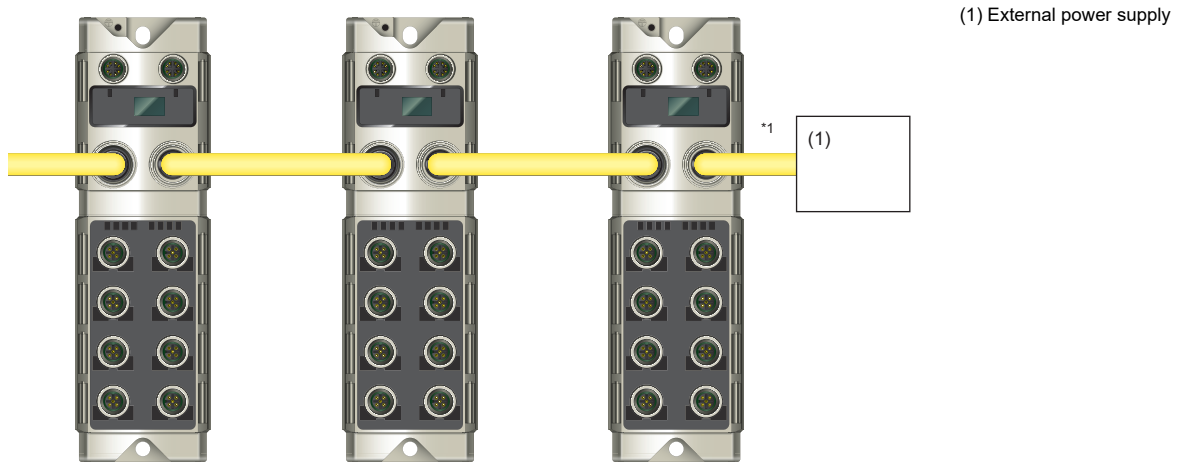

\*1 The largest current flows from the power supplier to the power supply connector of the first IO-Link module. Ensure that the current capacity of the power supply connector (for module/sensor power supply + actuator power supply) of the first IO-Link module does not exceed 9.3A.

### Point

For transition wiring, check the current consumption of each of wired IO-Link modules. For the current consumption of an IO-Link module, refer to the following. (☞ Page 21 Performance Specifications)

### Tightening torque

When connecting the power cable, tighten the waterproof plug to the following torque.

Screw type	Tightening torque
Power supply connector (7/8")	1.50N·m

## 5.4 Wiring of Ethernet Cable

This section describes wiring of Ethernet cable.

### Connecting the Ethernet cable

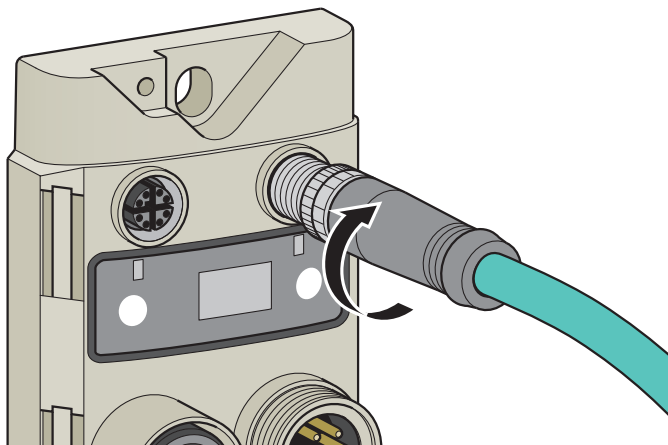
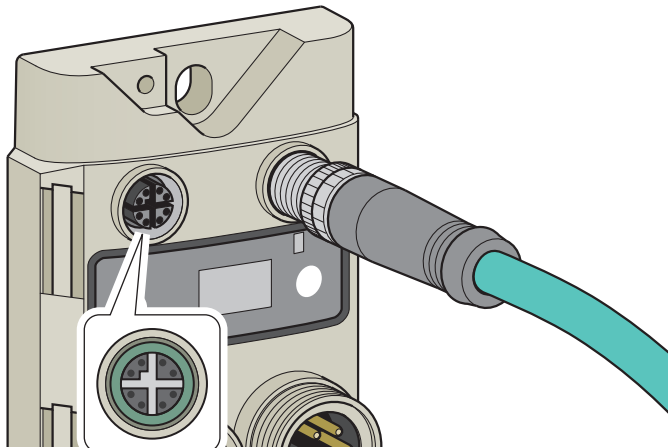

1. Power off the power supplies of the IO-Link module and the external device.
2. Insert an Ethernet cable connector into the IO-Link module. Pay attention to the connector's direction.

3. Tighten the waterproof plug of the Ethernet cable using a torque wrench. (☞ Page 40 Tightening torque)

4. Power on the power supply of the IO-Link module.
5. Power on the external device.
6. Check that the LINK LED of the port into which the Ethernet cable is connected is on.\*<sup>1</sup>

\*<sup>1</sup> The time taken for the LINK LED to turn on after connection of the cable may vary. The LINK LED normally turns on in a few second. However, if link-up processing is repeated due to a condition of a device on the line, the longer time may be required. If the LINK LED does not turn on, refer to the following and take a corrective action.

☞ Page 117 When the LINK LED is off



- Attach waterproof caps to connector not used.
- The product specifications are satisfied only when all of waterproof plugs are installed with the recommended connectable devices and all screws are tightened with an appropriate torque.
- Communication connectors P1 and P2 need not to be distinguished. When only one connector is used in star topology, either P1 or P2 can be connected.
- When two connectors are used in line topology or ring topology, an Ethernet cable can be connected to the connectors in any combination. For example, the cable can be connected between P1s and between P1 and P2.

[Connection between P1s and between P2s]

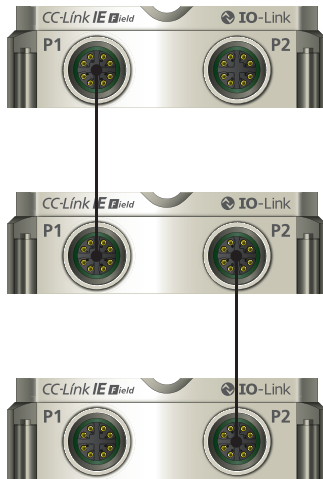

[Connection between P1 and P2]

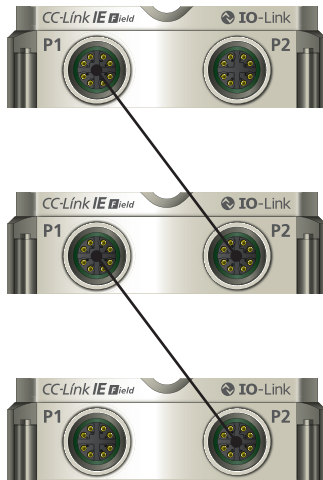

## Disconnecting the Ethernet cable

1. Power off the power supplies of the IO-Link module and the external device.
2. Loosen the waterproof plug of the Ethernet cable and remove the Ethernet cable.

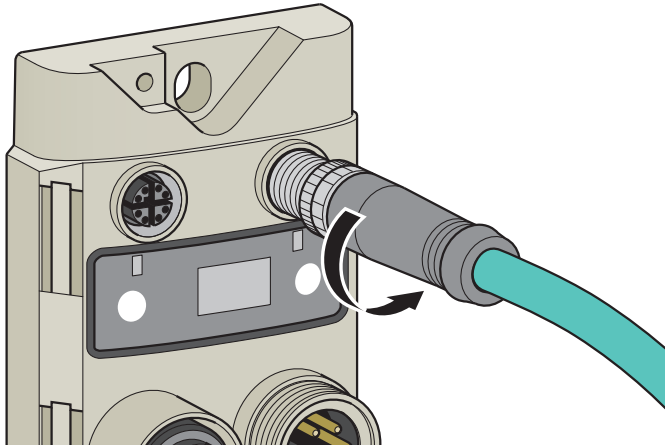

## Tightening torque

When connecting the Ethernet cable, tighten the waterproof plug to the following torque.

Screw type	Tightening torque
Communication connector (M12)	0.60N·m

## 5.5 Wiring the IO-Link Cable

This section describes wiring of IO-Link cable.

### Connecting the IO-Link cable

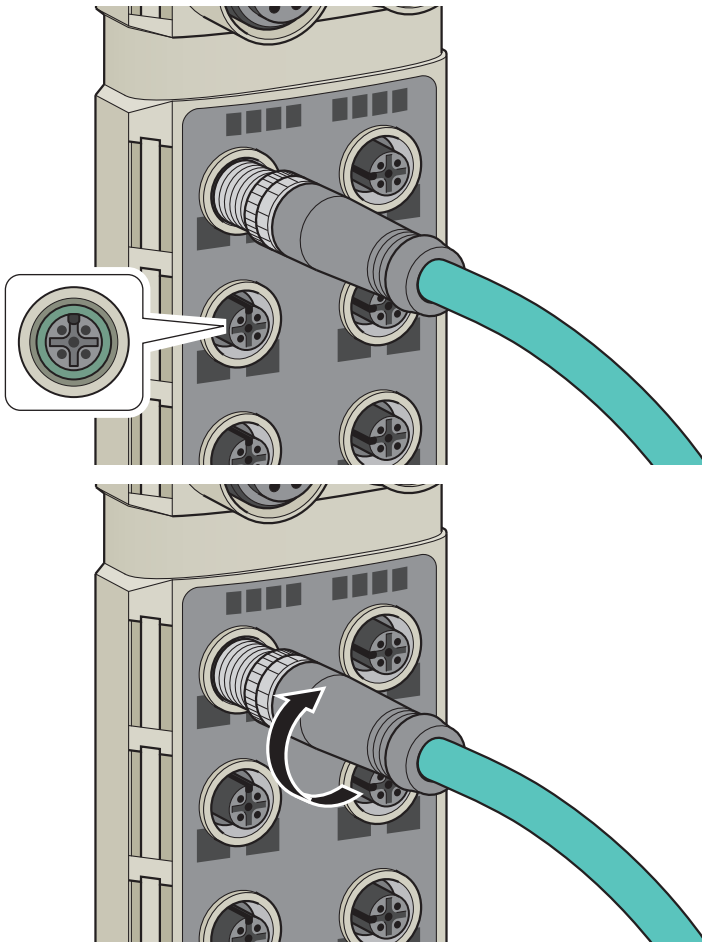

1. Power off the power supply of the IO-Link module.
2. Insert an IO-Link cable connector into the IO-Link module. Pay attention to the connector's direction.
3. Tighten the waterproof plug of the IO-Link cable using a torque wrench. (☞ Page 42 Tightening torque)
4. Power on the power supply of the IO-Link module.
5. Check that the CQ LED and Q LED of the channel to which the IO-Link cable is connected are in normal state. (☞ Page 15 LED names of the IO-Link module)

5

#### Point

- Attach waterproof caps to connector not used.
- The product specifications are satisfied only when all of waterproof plugs are installed with the recommended connectable devices and all screws are tightened with an appropriate torque. (☞ Page 31 Recommended Connectable Device List)

## Disconnecting the IO-Link cable

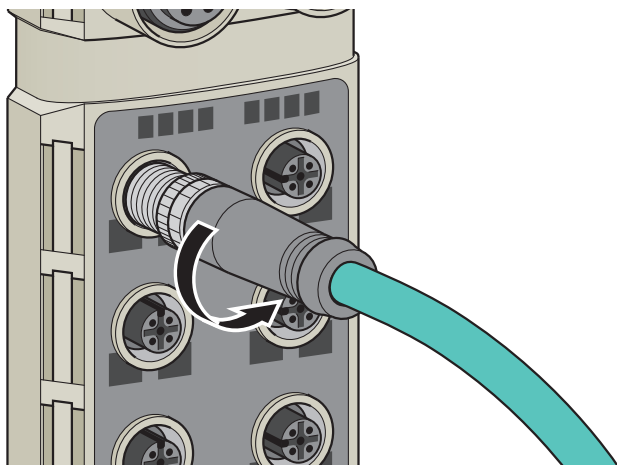

1. Power off the power supply of the IO-Link module.
2. Loosen the waterproof plug of the IO-Link cable and remove the IO-Link cable.

## Tightening torque

When connecting the IO-Link cable, tighten the waterproof plug to the following torque.

Screw type	Tightening torque
IO-Link connector (M12)	0.60N·m

## 5.6 Attaching Waterproof Caps

Tighten the waterproof caps within the following torque range.

Screw type	Tightening torque range
Waterproof cap (M12)	0.30 to 0.34N·m
Waterproof cap (7/8")	

### Point

The product specifications are satisfied only when all of waterproof caps are installed with the recommended connectable devices and all screws are tightened with an appropriate torque. (  Page 31 Recommended Connectable Device List)

# 5.7 Precautions

This section describes precautions for wiring the power cable, Ethernet cable, and IO-Link cable.

## Operating environment

Consider fully the operating environment and input response time of CQ and Q terminals because the module may take in noise as input when it is used in SIO mode (digital input).

## Laying cables

- Do not touch the core of the connector, and protect it from dirt and dust. If any oil from your hand, or any dirt or dust sticks to the core, it can increase transmission loss, causing data link to fail.
- For cables to be used, check the following.
  - Is any Ethernet cable disconnected?
  - Does any Ethernet cable short?
  - Are the connectors securely connected?

## Damage to cables

- Do not use a cable with a damaged screw part. Otherwise, the cable may be disconnected or malfunction may result.

## Connecting and disconnecting a cable

- Ensure that the direction of the cable is correct, and then connect the cable. Pulling the cable connected to the module may result in damage to the module or cable or malfunction due to poor contact.
- Use a torque wrench to connect or disconnect the cable with an appropriate torque.

## Unused connectors

- To prevent dust and water from entering the module, attach waterproof caps.

## Maximum cable distance

- The maximum station-to-station distance of Ethernet cables is 100m. However, the distance may be shorter depending on the operating environment of the cable. For details, contact the manufacturer of the cables used.
- The maximum distance of IO-Link cables is 20m. However, the distance may be shorter depending on the operating environment of the cable. For details, contact the manufacturer of the cables used.
- The maximum power cable distance needs to be determined in consideration of the operating voltage of the IO-Link module because voltage drop occurs due to the current flowing in the cable.

## Cable bending radius

- There are restrictions on the cable bending radius. Check the bending radius in the specifications of the cables used.

# 6 Parameter Setting

This chapter describes the procedure for setting parameters of the IO-Link module.

## 6.1 CC-Link IE Field Network Parameter Setting

### Setting via the engineering tool

Set the parameter of the IO-Link module with the network parameter written to the CPU module of the CC-Link IE Field Network master station. For details on setting the CC-Link IE Field Network master station, refer to the following.

📖 User's manual for the master/local module used

#### Setting procedure

1. Open the "CC IE Field Configuration" window.

For the master/local module RJ71GF11-T2

🔗 [Navigation window] ⇒ [Parameter] ⇒ [Module Information] ⇒ [RJ71GF11-T2] ⇒ [Module Parameter] ⇒ [Basic Settings] ⇒ [Network Configuration Settings]

2. Select an IO-Link module from "Module List", and drag and drop it to the list of stations or the network map.

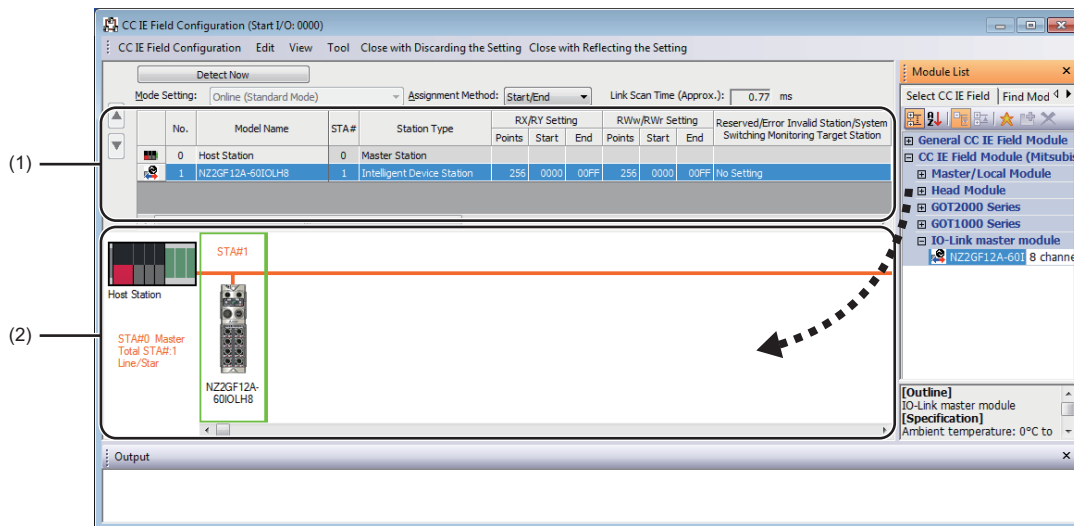

(1) List of stations

(2) Network map

3. Configure the IO-Link module settings.

Item	Description
STA#	Set the station number of a slave station to be connected to the network. The station number need not be a serial number. (Must not be overlapped.)
Station Type	Set "Intelligent Device Station".
RX/Ry Setting	Set RX and RY assignment. For IO-Link modules, set 80 points or more.
RWw/RW <sub>r</sub> Setting	Set RWw and RW <sub>r</sub> assignment in units of four points. For IO-Link modules, this setting should be determined by the functions used. <ul style="list-style-type: none"> <li>• IO-Link mode: 4 to 132 points (IO-Link module main: 4 points, process data: 0 to 128 points)<sup>*1</sup></li> <li>• SIO mode: 4 points</li> </ul>
Reserved/Error Invalid Station/System Switching Monitoring Target Station	Use this to set the slave station as an error invalid station or a switching monitoring target station.

\*1 Note that necessary points vary depending on the connected IO-Link device. For details, refer to the manual of the IO-Link device.

The points of "RWw/RWr Setting" can be increased/decreased in increments of four points. Decreasing the points of "RWw/RWr Setting" shortens the link refresh time when some remote register areas are not used.

**4.** Close the "CC IE Field Configuration" window.

 [CC IE Field Configuration] ⇒ [Close with Reflecting the Setting]

## Precautions

### ■Precautions before parameter settings

For the precautions before parameter settings, refer to the following.

 GX Works3 Operating Manual

 GX Works2 Version 1 Operating Manual (Common)

### ■Precautions for parameter settings

- When using the IO-Link module, always enable the station-based block data assurance. When it is disabled, correct operation of the IO-Link module cannot be guaranteed. For details on the block data assurance per station, refer to the following: User's manual for the master/local module used.

Setting Item	Item	Setting
	<b>Supplementary Cyclic Settings</b>	
	System Switching Monitoring Time	2000 ms
	Link Scan Mode	Sequence Scan Asynchronous
	Constant Link Scan Time	0 ms
	<b>Station-based Block Data Assurance</b>	Enable
	<b>IO Maintenance Settings</b>	
	Output Hold/Clear Setting during CPU STOP	Hold
	Data Link Error Station Setting	Clear
	Output Mode upon CPU Error	Clear

- Do not set the parameter using the CCPASET instruction in the master station. Correct operation of the IO-Link module cannot be guaranteed because the module operates with the station-based block data assurance disabled when the CCPASET instruction is executed. (The CCPASET instruction is intended to configure parameters for a master/local module. For details on the CCPASET instruction, refer to the user's manual for the master/local module used.)



# 6.2 IO-Link Module Parameter Setting

## Setting via the engineering tool

This section describes the procedure for setting parameters of IO-Link module via the engineering tool.

### Setting procedure

1. Open the "CC IE Field Configuration" window.

For the master/local module RJ71GF11-T2

[Navigation window] ⇒ [Parameter] ⇒ [Module Information] ⇒ [RJ71GF11-T2] ⇒ [Module Parameter] ⇒ [Basic Settings] ⇒ [Network Configuration Settings]

2. Open the "Parameter Processing of Slave Station" window.

From the list of stations, select an IO-Link module ⇒ [CC IE Field Configuration] ⇒ [Online] ⇒ [Parameter Processing of Slave Station].

3. Set "Method selection" to "Parameter Write".

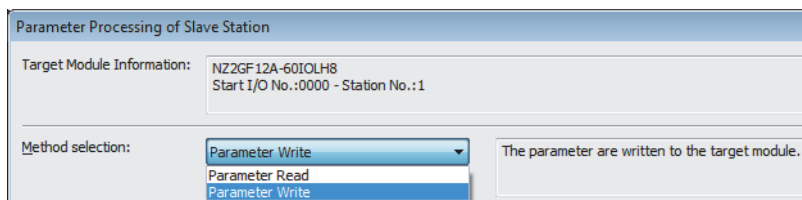

4. Double-click the item to change the setting, and input the setting value.

- Items to input from the pull-down list

Double-click the item to set, to display the pull-down list. Select the item.

- Items to input from the text box

Double-click the item to set, and input the setting value.

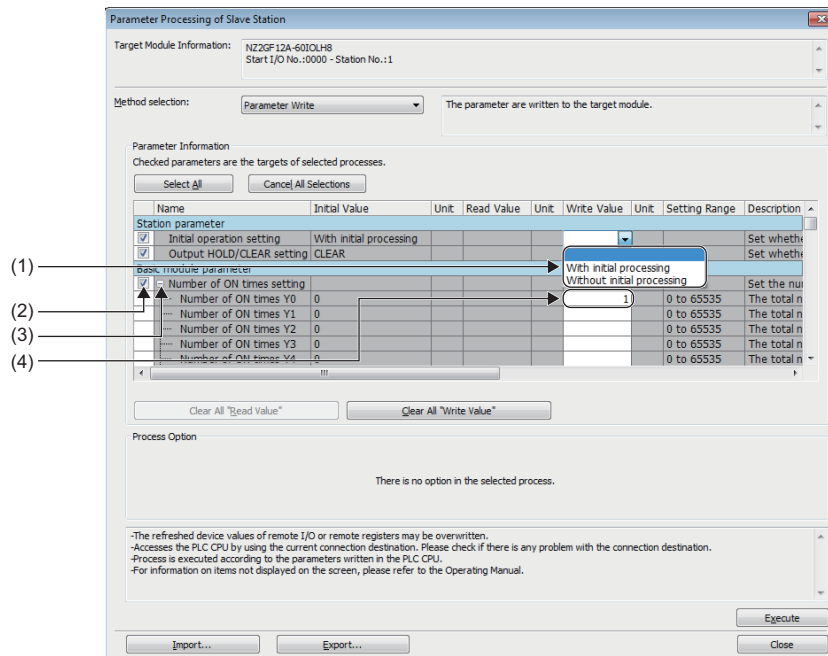

(1) Items to input from the drop-down list

(2) Checkbox

(3) The list cannot be collapsed.

(4) Items to input from the text box

The following table lists the items to configure.

Setting item		Reference
Station parameter	Initial operation setting	Page 80 Initial Operation Setting Function
	Output HOLD/CLEAR setting	Page 93 Output HOLD/CLEAR setting function
Basic module parameter	Number of ON times setting	Page 77 Number of SIO output ON times integration function
	Pin configuration setting	Page 63 IO-Link cyclic transmission function Page 75 SIO input function Page 76 SIO output function
IO-Link parameter (Channel 1 to channel 8 setting)	Process data size	Page 63 IO-Link cyclic transmission function
	Swap setting	Page 73 Swap function
	Data storage configuration	Page 66 IO-Link device setting automatic upload/download function
	Validation setting	Page 69 IO-Link device validation function
	Vendor ID	
	Device ID	

5. Click the [Execute] button and the following window is displayed.

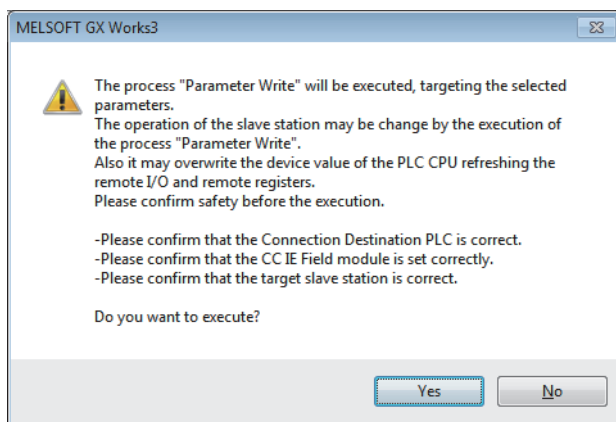

6. Click the [Yes] button.

7. The parameters are written to the IO-Link module.

8. Select [Close with Reflecting the Setting] to exit the network configuration setting.

### Point

- Select parameters to be set.
- Set all the items for the selected parameters. If any blank exists, the parameters cannot be written to the IO-Link module.
- To read the parameter from the IO-Link module, set "Method selection" to "Parameter Read" and click the [Execute] button.

## Precautions

### ■Precautions for writing parameters

Parameters of the IO-Link module are written to the flash memory and retained even after the IO-Link module is powered off.

Parameters are written at the following timing.

- When Operation condition setting request flag (RWw0.b9) turns off and on
- Immediately after the engineering tool parameters are written

Note that parameters can be written even when its data is invalid, but an error occurs when the write is complete.

# Setting via a program

---

Use a dedicated instruction to set parameters.

## Setting procedure

**1.** Use an RIWT instruction to set parameters.

For details on parameters and the procedure for setting parameters, refer to the following.

☞ Page 83 Data that can be read and written in transient transmission

☞ Page 101 Program Example of Setting Parameters Using a Dedicated Instruction

**2.** Turn on Initial processing completion flag (RWw0.b8).

**3.** Check that the Initial processing request flag (RWr0.b8) is turned off and there is no initial processing request. After the check, turn off Initial processing completion flag (RWw0.b8).

**4.** Check that Remote READY (RWr0.b11) is turned on.

## 6.3 Changing the IO-Link Module Parameters

This section describes the procedure for changing the parameter.

The precautions for changing the parameter are the same as those in the following section.

☞ Page 46 Precautions

### Setting via the engineering tool

#### Changing the network configuration

When changing the network configuration diverting the created project, set the parameter in the following procedure.

1. Power off the module.
2. Connect the modules again according to the desired network configuration.
3. Power on the module.
4. Open the "CC IE Field Configuration" window.

For the master/local module RJ71GF11-T2

☞ [Navigation window] ⇒ [Parameter] ⇒ [Module Information] ⇒ [RJ71GF11-T2] ⇒ [Module Parameter] ⇒ [Basic Settings] ⇒ [Network Configuration Settings]

5. Drag and drop a module to set the IO-Link module. Input a numerical value to set the station number of the station. Change the value as necessary.

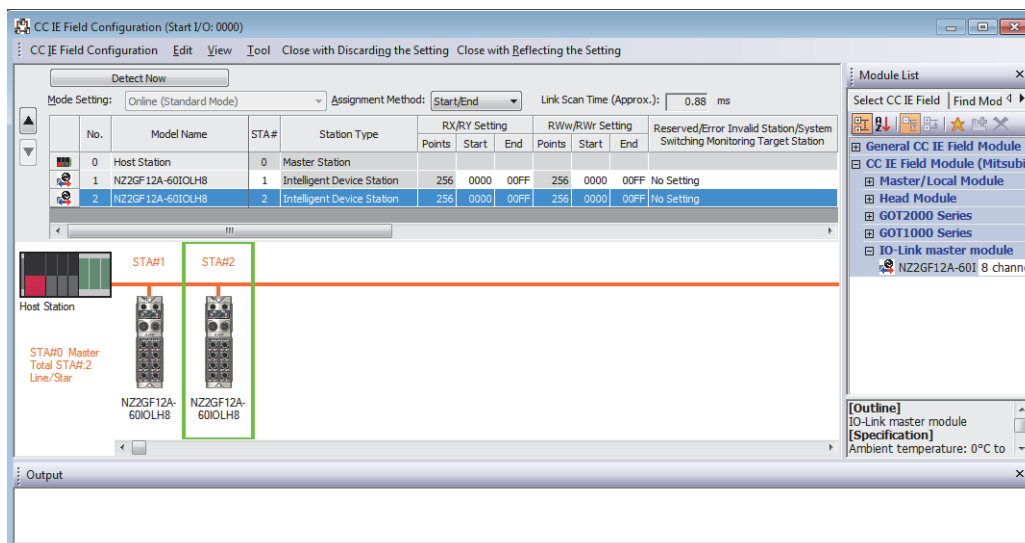

6. Open the "Parameter Processing of Slave Station" window.

From the list of stations, select an IO-Link module ⇒ [CC IE Field Configuration] ⇒ [Online] ⇒ [Parameter Processing of Slave Station].

7. Set "Method selection" to "Parameter Read".

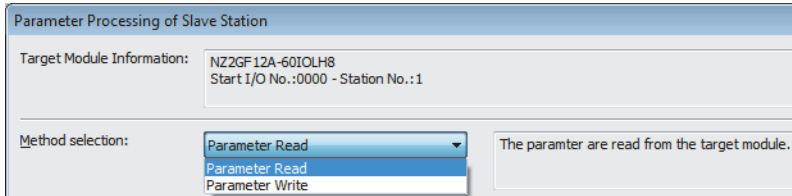

8. Click the [Execute] button and the following window is displayed.

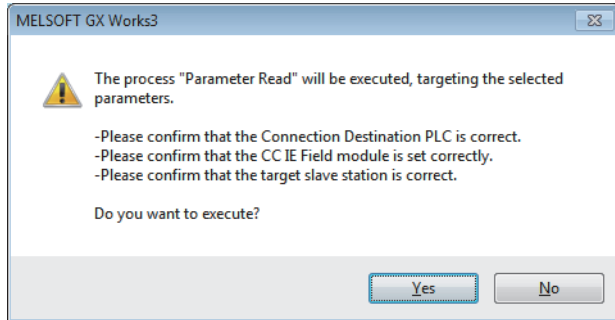

9. Click the [Yes] button.

10. The parameters are read from the IO-Link module.

Name	Initial Value	Unit	Read Value	Unit	Write Value	Unit	Setting Range	Description
<b>Station parameter</b>								
<input checked="" type="checkbox"/> Initial operation setting	With initial...		With initial processing					Set whether
<input checked="" type="checkbox"/> Output HOLD/CLEAR setting	CLEAR		CLEAR					Set whether
<b>Basic module parameter</b>								
<input checked="" type="checkbox"/> Number of ON times setting								Set the num
Number of ON times Y0	0		0				0 to 65535	The total nu
Number of ON times Y1	0		0				0 to 65535	The total nu
Number of ON times Y2	0		0				0 to 65535	The total nu
Number of ON times Y3	0		0				0 to 65535	The total nu
Number of ON times Y4	0		0				0 to 65535	The total nu

11. Set "Method selection" to "Parameter Write".

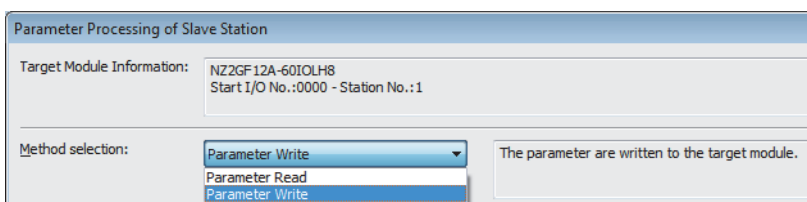

12. Set "Write Value". The following are the procedure.

- Click the title cell of "Read Value" to select all the items and copy them.
- Click the title cell of "Write Value" to select all the items and paste the copy.
- Select the items to be changed, and set new values.

Name	Initial Value	Unit	Read Value	Unit	Write Value	Unit	Setting Range	Descr
<b>Station parameter</b>								
<input checked="" type="checkbox"/> Initial operation setting	With initial...		With initial processing		With initial processing			Set
<input checked="" type="checkbox"/> Output HOLD/CLEAR setting	CLEAR		CLEAR		CLEAR			Set
<b>Basic module parameter</b>								
<input checked="" type="checkbox"/> Number of ON times setting								Set
Number of ON times Y0	0		0		0		0 to 65535	The
Number of ON times Y1	0		0		0		0 to 65535	The
Number of ON times Y2	0		0		0		0 to 65535	The
Number of ON times Y3	0		0		0		0 to 65535	The
Number of ON times Y4	0		0		0		0 to 65535	The

13. Click the [Execute] button and the following window is displayed.

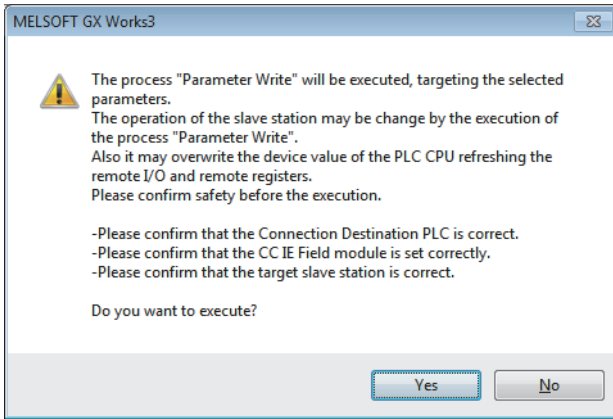

14. Click the [Yes] button.

15. The parameter is written to the I/O module. Click the [Close] button.

16. Close the "CC IE Field Configuration" window.

[CC IE Field Configuration] ⇒ [Close with Reflecting the Setting]

17. Set the refresh parameter. Change the value as necessary.

[Navigation window] ⇒ [Parameter] ⇒ [Module Information] ⇒ [RJ71GF11-T2] ⇒ [Module Parameter] ⇒ [Basic Settings] ⇒ [Refresh Settings]

No.	Link Side					CPU Side				
	Device Name	Points	Start	End		Target	Device Name	Points	Start	End
-	SB	512	00000	001FF	↔	Specif	SB	512	00000	001FF
-	Sw	512	00000	001FF	↔	Specif	Sw	512	00000	001FF
1	RX	256	00100	001FF	↔	Specif	X	256	00100	001FF
2	RY	256	00100	001FF	↔	Specif	Y	256	00100	001FF
3	RWr	256	00100	001FF	↔	Specif	W	256	00100	001FF
4	Rww	256	00100	001FF	↔	Specif	W	256	00500	005FF

18. Click the [Apply] button.

19. Write the set parameters to the CPU module of the master station and reset the CPU module.

20. Change the status of the CPU module of the master station to RUN.

The network configuration setting is now completed.

## Changing the parameter without changing the network configuration

To change only the created module parameter of the slave station without changing the network configuration, set the parameter in the following procedure.

1. Open the "CC IE Field Configuration" window.

For the master/local module RJ71GF11-T2

[Navigation window] ⇒ [Parameter] ⇒ [Module Information] ⇒ [RJ71GF11-T2] ⇒ [Module Parameter] ⇒ [Basic Settings] ⇒ [Network Configuration Settings]

2. Open the "Parameter Processing of Slave Station" window.

From the list of stations, select an IO-Link module ⇒ [CC IE Field Configuration] ⇒ [Online] ⇒ [Parameter Processing of Slave Station].

3. Set "Method selection" to "Parameter Read".

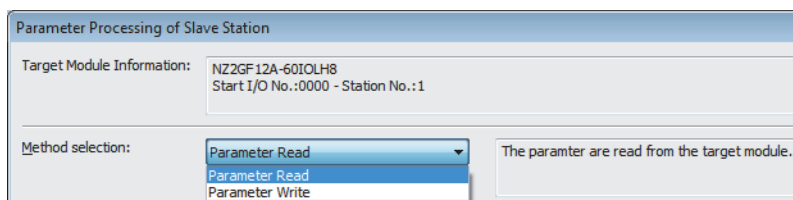

4. Click the [Execute] button and the following window is displayed.

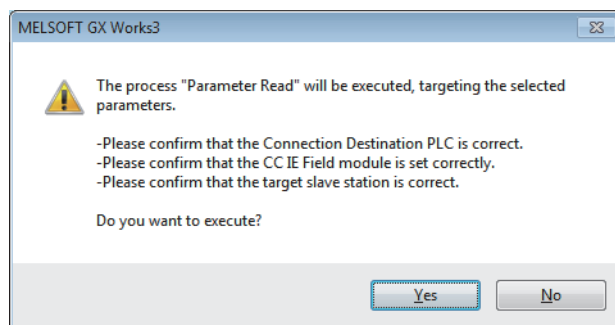

5. Click the [Yes] button.

6. The parameters are read from the IO-Link module.

Name	Initial Value	Unit	Read Value	Unit	Write Value	Unit	Setting Range	Description
<b>Station parameter</b>								
<input checked="" type="checkbox"/> Initial operation setting	With initial...		With initial processing					Set whether
<input checked="" type="checkbox"/> Output HOLD/CLEAR setting	CLEAR		CLEAR					Set whether
<b>Basic module parameter</b>								
<input checked="" type="checkbox"/> Number of ON times setting								Set the num
Number of ON times Y0	0		0				0 to 65535	The total nu
Number of ON times Y1	0		0				0 to 65535	The total nu
Number of ON times Y2	0		0				0 to 65535	The total nu
Number of ON times Y3	0		0				0 to 65535	The total nu
Number of ON times Y4	0		0				0 to 65535	The total nu

7. Set "Method selection" to "Parameter Write".

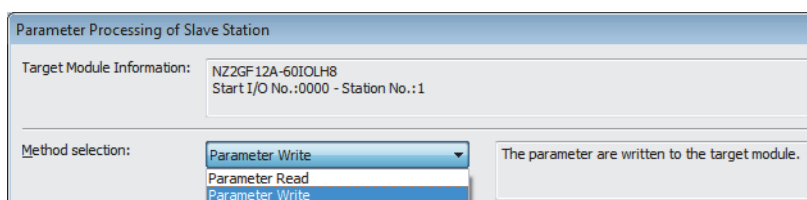



8. Set "Write Value". The following are the procedure.

- Click the title cell of "Read Value" to select all the items and copy them.
- Click the title cell of "Write Value" to select all the items and paste the copy.
- Select the items to be changed, and set new values.

Name	Initial Value	Unit	Read Value	Unit	Write Value	Unit	Setting Range	Desc
<b>Station parameter</b>								
<input checked="" type="checkbox"/>	Initial operation setting	With initial...	With initial processing		With initial processing			Set
<input checked="" type="checkbox"/>	Output HOLD/CLEAR setting	CLEAR	CLEAR		CLEAR			Set
<b>Basic module parameter</b>								
<input checked="" type="checkbox"/>	Number of ON times setting							Set
	Number of ON times Y0	0	0		0		0 to 65535	The
	Number of ON times Y1	0	0		0		0 to 65535	The
	Number of ON times Y2	0	0		0		0 to 65535	The
	Number of ON times Y3	0	0		0		0 to 65535	The
	Number of ON times Y4	0	0		0		0 to 65535	The

9. Click the [Execute] button and the following window is displayed.

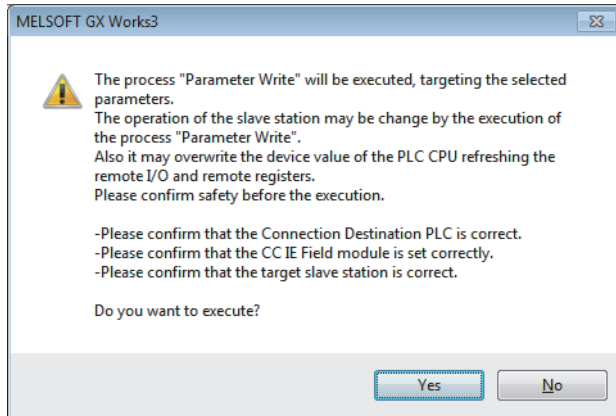

10. Click the [Yes] button.

11. The parameter is written to the I/O module.

The module parameter setting of the slave station is completed.

## Setting via a program

---

This section describes the procedure for changing the parameter.

### Changing the network configuration

1. Power on and off the module.
2. Connect the modules again according to the desired network configuration.
3. Power on the module.
4. Perform the following steps 1 to 3.

☞ Page 50 Setting via a program

### Changing the parameters without changing the network configuration

1. Use an RIWT instruction to set parameters to change.

For details on parameters and the procedure for setting parameters, refer to the following.

☞ Page 83 Data that can be read and written in transient transmission

☞ Page 101 Program Example of Setting Parameters Using a Dedicated Instruction

2. Turn on Initial processing completion flag (RWw0.b8).
3. Check that the Initial processing request flag (RWr0.b8) is turned off and there is no initial processing request. After the check, turn off Initial processing completion flag (RWw0.b8).
4. Check that Remote READY (RWr0.b11) is turned on.

## 6.4 IO-Link Device Parameter Setting

Using CommDTM for IO-Link master module in FDT, IO-Link device parameters can be read or written and data can be monitored via the IO-Link module. In addition, multiple IO-Link devices can be managed from one place. IODD can be converted to Device DTM using IODD DTM Configurator. IODD is supplied from the sensor manufacturer.

### Setting procedure when FDC and CommDTM are used

The following describes how to set the IO-Link device parameter.

#### Setting procedure

1. Install IODD using the installer supplied from the manufacturer of the sensor. Convert IODD supplied from the sensor manufacturer to Device DTM using IODD DTM Configurator. When Device DTM is supplied from the sensor manufacturer, this operation is not necessary.

☞ Page 59 Conversion procedure of IODD

2. When GX Works3 is used, double-click the IO-Link module in the network map in GX Works3 after installing Device DTM. When GX Works2 is used, start FDC directly.

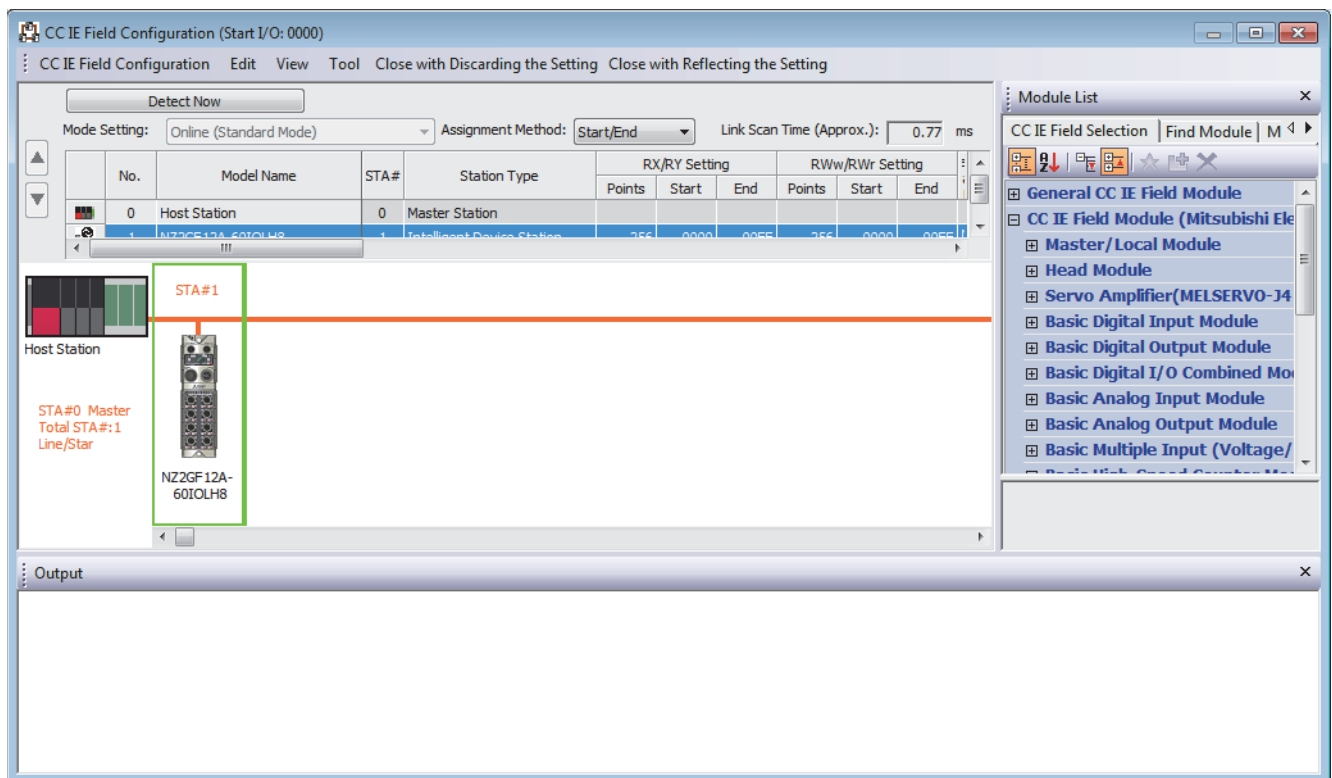

3. Register M\_CommDTM-IOLink and Device DTM to the DTM catalog of FDC. This registration is necessary only for the first startup. It will not be necessary for the next and subsequent startups.

4. Click the [Update] button to start the update of the DTM catalog.

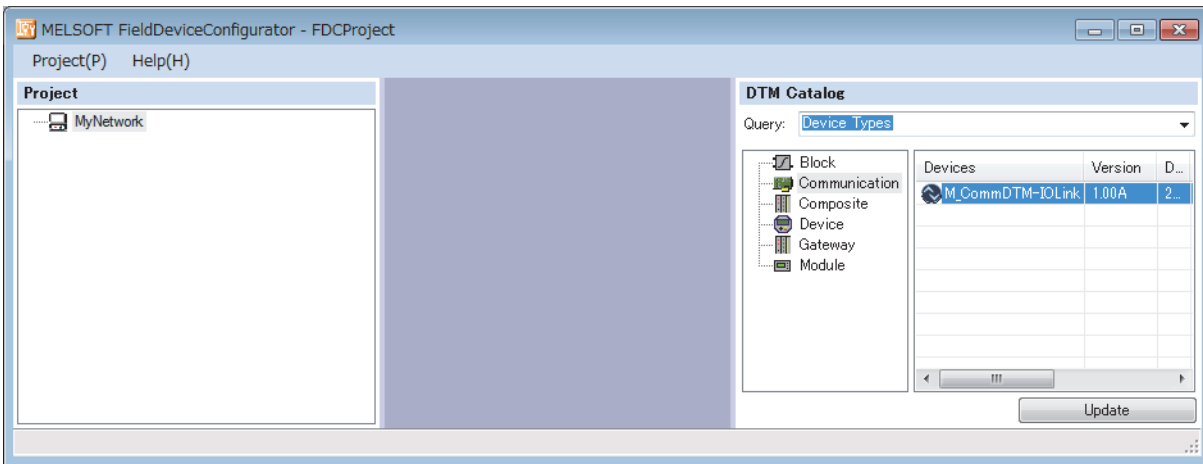

5. Create an FDC project.

☞ Page 60 Creation procedure of FDC project

6. Add M\_CommDTM-IOLink to the created FDC project.

Import the communication setting of M\_CommDTM-IOLink to GX Works3.

☞ Page 61 Procedure for adding M\_CommDTM-IOLink

☞ Page 61 Procedure for configuring communication setting with M\_CommDTM-IOLink

7. The connected IO-Link device is automatically detected.

☞ [M\_CommDTM-IOLink] ⇒ Right-click ⇒ [Detect Now] ⇒ [Execute to All Channels] or [Execute to Selected Channels]

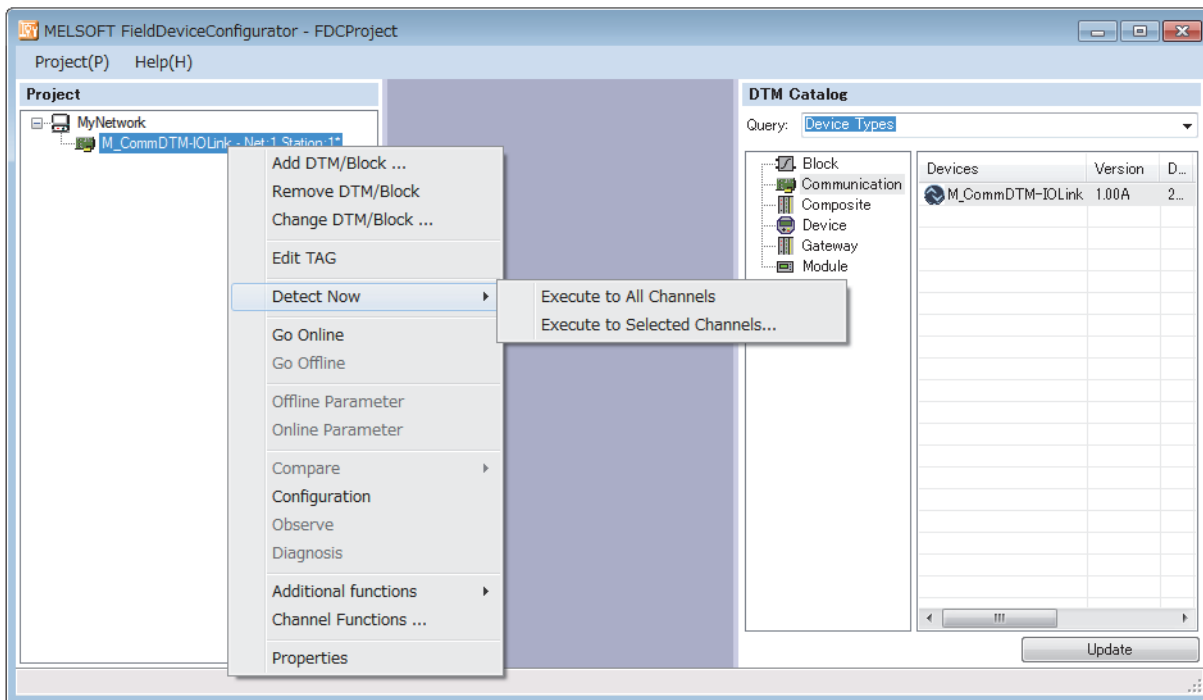

8. IO-Link device is detected.

9. Write the parameter of the connected IO-Link device.

☞ Page 62 Parameter writing procedure to IO-Link device

# Conversion procedure of IODD

The following describes how to convert IODD.

## Conversion procedure

1. Store IODD to the hard disk on the personal computer.
2. Start IODD DTM Configurator. Device DTM already converted to IODD is listed on the window. (If no Device DTM already converted to IODD has been added, the list is blank.)

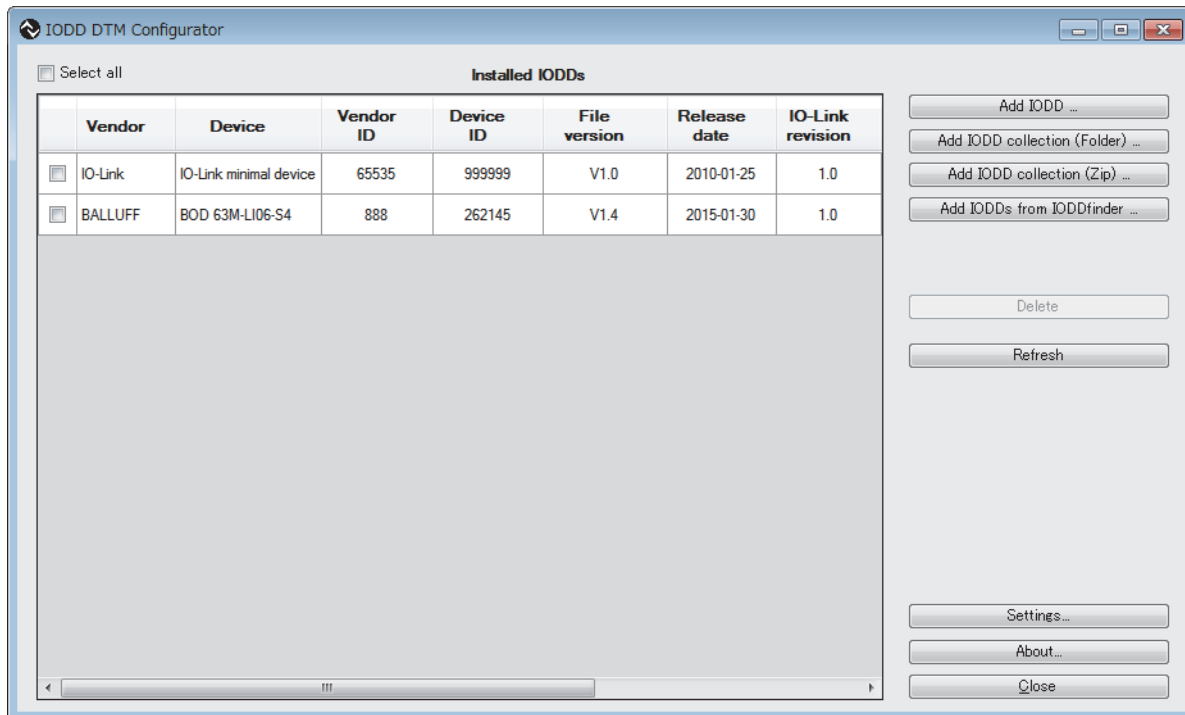

3. Click the [Add IODD ...] button.
4. Select the XML file of IODD to be read, and click the [Open] button.

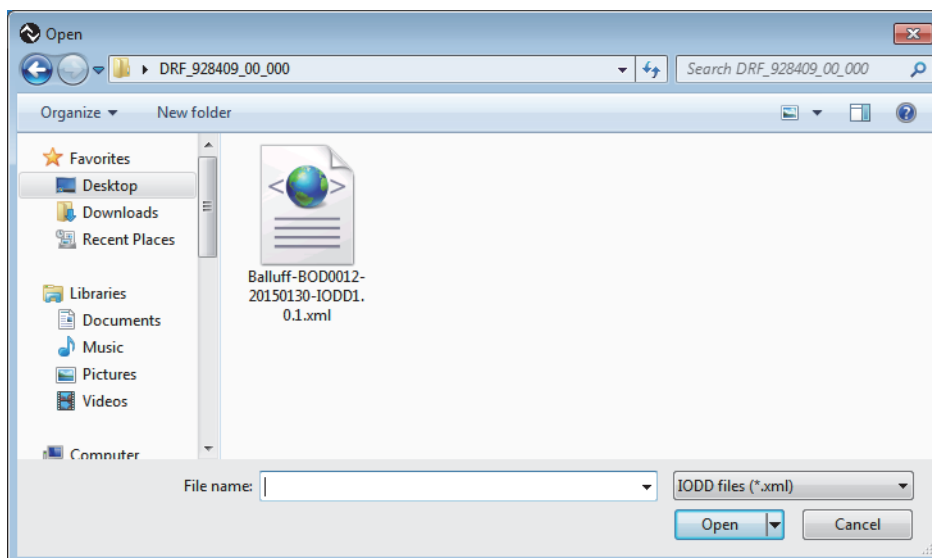

5. Check that IODD is added properly, and click the [Close] button. IODD will be converted to Device DTM.

# Creation procedure of FDC project

---

The following describes how to create an FDC project.

## Creation procedure

1. Open the "New Project" window from the menu.

 [Project] ⇒ [New Project]

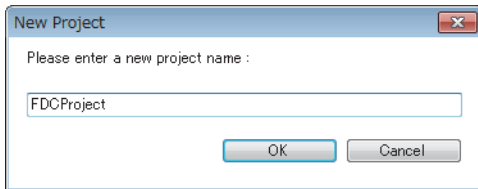

2. Enter the FDC project name, and click the [OK] button.

# Procedure for adding M\_CommDTM-IOLink

The following describes how to add M\_CommDTM-IOLink.

## Addition procedure

1. Select M\_CommDTM-IOLink from the DTM catalog, and click the [OK] button.

🖱️ FDC project tree ⇒ [MyNetwork] ⇒ Right-click ⇒ [Add DTM]

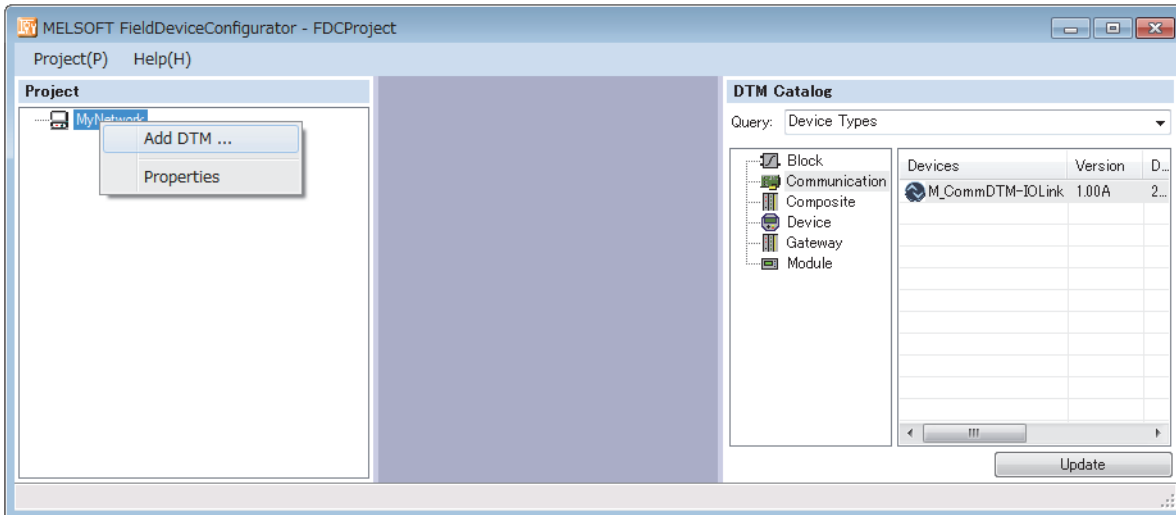

2. M\_CommDTM-IOLink is added to the FDC project.

# Procedure for configuring communication setting with M\_CommDTM-IOLink

The following describes how to import the communication setting of M\_CommDTM-IOLink from GX Works3.

## Communication setting procedure

1. Import the communication setting of M\_CommDTM-IOLink from the connection destination specification and the network configuration setting information of GX Works3. Double-click M\_CommDTM-IOLink to display the FDC project.
2. Click the [Import] button.
3. The network configuration setting information of GX Works3 is imported, and the communication setting is updated. Click the [OK] button to determine the setting.

## Precautions

The import function can be used only when FDC is started from GX Works3. When FDC is started directly, the import function is disabled, and therefore the communication setting needs to be configured from FDC separately.

# Parameter writing procedure to IO-Link device

The following describes how to write parameters to the IO-Link device.

## Writing procedure

1. Make the online connection between the personal computer and the IO-link device.  
FDC project tree ⇒ [M\_CommDTM-IOLink] ⇒ Right-click ⇒ [Go Online]
2. Configure the parameter setting of the IO-Link device. Right-click on the Device DTM node of the control target, and select [Configuration] in the context menu displayed by right-clicking to start the Device DTM setting window.
3. Configure the setting according to the usage in the displayed Device DTM setting window. For setting details of Device DTM supplied from the sensor manufacturer, refer to the manual supplied from the manufacturer.

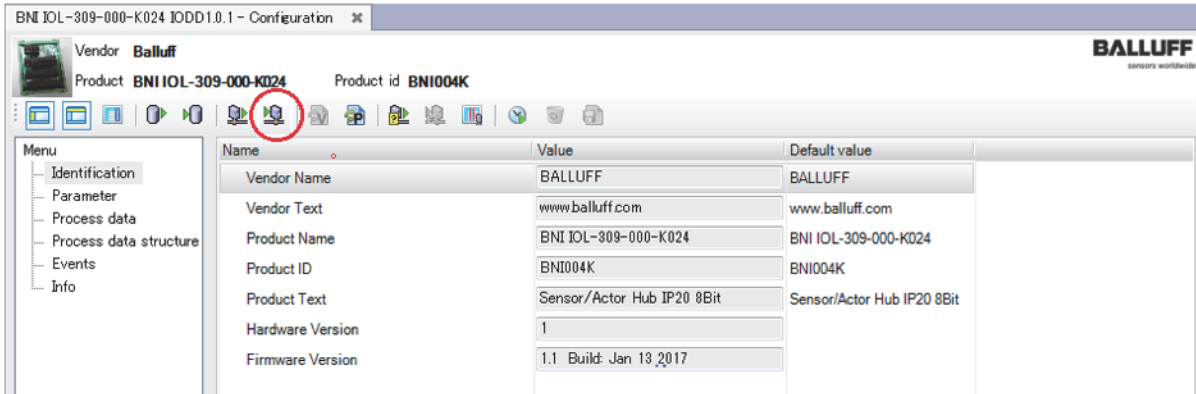

4. Write the parameter set for the IO-Link device. Click the icon to write the Device DTM setting to the connected IO-Link device.



# 7 FUNCTIONS

This chapter describes the details of the functions available in the IO-Link module, and the setting procedures for those functions.

For details on remote I/O signals and remote registers, refer to the following.

☞ Page 131 Details of remote input signals

☞ Page 140 Details of Remote Registers

## 7.1 IO-Link Master Functions

### IO-Link cyclic transmission function

This function communicates process data periodically with the IO-Link device connected to each channel.

Use this function to retrieve information from and control the IO-Link device in real time. A maximum of 32 bytes process data can be communicated. The data size and structure vary depending on the connected IO-Link module.

Because the default setting of each channel is SIO mode input, enable the IO-Link mode corresponding to the remote output signal (RY) channel in initial processing to perform IO-Link communication.

To apply the IO-Link mode enabled during operation, turn on Operation condition setting request flag (RWw0.b9).

#### Input/output process data area

The IO-Link module reads and writes process data from/to the IO-Link device connected to each channel via the remote register (RWr/RWw).

#### Setting procedure

1. Open the "CC IE Field Configuration" window.

For the master/local module RJ71GF11-T2

☞ [Navigation window] ⇒ [Parameter] ⇒ [Module Information] ⇒ [RJ71GF11-T2] ⇒ [Module Parameter] ⇒ [Basic Settings] ⇒ [Network Configuration Settings]

2. Open the "Parameter Processing of Slave Station" window.

☞ From the list of stations, select an IO-Link module ⇒ [CC IE Field Configuration] ⇒ [Online] ⇒ [Parameter Processing of Slave Station].

3. Set "Method selection" to "Parameter Write".

4. For each channel of "Pin configuration setting", set "Write Value" as follows.

- CQ: "IOL"
- Q: "INPUT" or "OUTPUT"

Name	Initial Value	Unit	Read Value	Unit	Write Value	Unit	Setting Range	Description
☑ Pin configuration setting								Set the pin con
Configuration Port 1 CQ								The configurati
Configuration Port 1 Q								The configurati
Configuration Port 2 CQ								The configurati
Configuration Port 2 Q								The configurati
Configuration Port 3 CQ								The configurati
Configuration Port 3 Q								The configurati
Configuration Port 4 CQ								The configurati
Configuration Port 4 Q								The configurati
Configuration Port 5 CQ								The configurati

5. For each channel, set "Write Value" of "Process data size".

Name	Initial Value	Unit	Read Value	Unit	Write Value	Unit	Setting Range	Description
<b>IO-Link parameter</b>								
<input checked="" type="checkbox"/> Channel 0 configuration setting								Set IO-Link chann
Process data size	1 word							Set process data s
Swap setting	Disable							Disable or enable v
Data storage setting	Disable							Disable or enable c
Validation setting	Disable							Set to disable, cor
Validation Vendor ID	0x0000	hex		hex		hex		Set vendor ID if va
Validation Device ID	0x00000000	hex		hex		hex		Set device ID if va
Serial Number Character 3-0	0x00000000	hex		hex		hex		Set Serial number
Serial Number Character 7-4	0x00000000	hex		hex		hex		Set Serial number

Clear All "Read Value"      Clear All "Write Value"

Process Option

There is no option in the selected pr

Item	Setting range
Process data size <sup>*1</sup>	<ul style="list-style-type: none"> <li>• 0 word</li> <li>• 1 word</li> <li>• 2 words</li> <li>• 3 words</li> <li>• 4 words</li> <li>• 5 words</li> <li>• 6 words</li> <li>• 7 words</li> <li>• 8 words</li> <li>• 9 words</li> <li>• 10 words</li> <li>• 11 words</li> <li>• 12 words</li> <li>• 13 words</li> <li>• 14 words</li> <li>• 15 words</li> <li>• 16 words</li> </ul>

\*1 For the process data size, specify the number of words not less than the process data size of the IO-Link device used. (If the IO-Link device controls 3-byte process data, set the process data size to two words (4 bytes) or more.)

## IO-Link transient communication function

---

This function reads/writes the IO-Link module and IO-Link device parameters at any timing from/to the IO-Link device connected to each channel.

This function uses a program to read and write parameters.

For details on data to read and write, refer to the following.

 Page 83 Data that can be read and written in transient transmission

# IO-Link device setting automatic upload/download function

This function saves the parameter setting of the IO-Link device connected to each channel in the IO-Link module, and as necessary, overwrites the parameter setting of the IO-Link devices.

Use this function to inherit parameter setting of an IO-Link device when replacing it.

The CQ LED flashes in green during uploading or downloading.

On the parameter setting window of the engineering tool or via a program, enable/disable automatic download of IO-Link device parameters and automatic upload of directly modified IO-Link device parameters for each channel.

For details on setting parameters via a program, refer to the following.

 Page 88 Data storage configuration

## Description

The following table lists the IO-Link device conditions, and relevant settings and operations.

IO-Link module condition	Setting details		Operation after executing the function
	Download setting	Upload setting	
No parameter setting data	Disabled	Disabled	No processing
		Enabled	Upload
	Enabled	Disabled	Upload <sup>*2</sup>
		Enabled	Upload
With parameter setting data <sup>*1</sup>	Disabled	Disabled	No processing
		Enabled	Upload
	Enabled	Disabled	Download
		Enabled	Download <sup>*3</sup>

\*1 No processing is performed if the parameter setting data in the connected IO-Link device is not compatible with the parameter setting data in the IO-Link module.

\*2 When the IO-Link module has no parameter setting data, parameter setting data will be uploaded even when the upload setting is disabled.

\*3 Depending on the IO-Link device setting, the upload operation may take precedence even when the download setting is enabled. ( Page 68 Precautions)

## Setting procedure

**1.** Open the "CC IE Field Configuration" window.

For the master/local module RJ71GF11-T2

 [Navigation window] ⇒ [Parameter] ⇒ [Module Information] ⇒ [RJ71GF11-T2] ⇒ [Module Parameter] ⇒ [Basic Settings] ⇒ [Network Configuration Settings]

**2.** Open the "Parameter Processing of Slave Station" window.

 From the list of stations, select an IO-Link module ⇒ [CC IE Field Configuration] ⇒ [Online] ⇒ [Parameter Processing of Slave Station].

**3.** Set "Method selection" to "Parameter Write".

4. For each channel, set "Write Value" of "Data storage setting".

Name	Initial Value	Unit	Read Value	Unit	Write Value	Unit	Setting Range	Description
<b>IO-Link parameter</b>								
<input checked="" type="checkbox"/> Channel 0 configuration setting								Set IO-Link chann
Process data size	1 word							Set process data s
Swap setting	Disable							Disable or enable v
Data storage setting	Disable							Disable or enable c
Validation setting	Disable							Set to disable, cor
Validation Vendor ID	0x0000	hex		hex	Disable			Set vendor ID if v
Validation Device ID	0x00000000	hex		hex	Upload			Set device ID if va
Serial Number Character 3-0	0x00000000	hex		hex	Download			Set Serial number
Serial Number Character 7-4	0x00000000	hex		hex	Upload/Download			Set Serial number
					Clear			

Item	Setting range
Data storage setting	<ul style="list-style-type: none"> <li>• Disable</li> <li>• Upload</li> <li>• Download</li> <li>• Upload/Download</li> <li>• Clear</li> </ul>

## Precautions

If the following ISDU data is written using the RIWT instruction of the program, upload to the IO-Link device is executed even if the IO-Link module has parameter setting data.

To upload data without using the RIWT instruction, set "Data storage setting" to "Clear" to delete the parameter setting data in the IO-Link module.

To enable the IO-Link device setting automatic upload/download function, set the device validation setting to "Compatible" or "Identical".

[Upload setting of the IO-Link device (ISDU data write)]

Item	Description <sup>*1</sup>
Access code	30H
Attribute code	05H
Address code	00H to 07H (each channel number)
Data size	6 bytes
Data	<ul style="list-style-type: none"><li>• Index: 0002H</li><li>• Subindex: 00H</li><li>• Control data: 80H</li><li>• Request data: 05H</li></ul>

\*1 For details on the settings, refer to the IO-Link specifications (IO-Link Interface and System Specification V1.1.2). ([www.io-link.com/](http://www.io-link.com/))

# IO-Link device validation function

This function validates compatibility and identity of the IO-Link device connected to each channel.

This function can be used to recognize connection with unintended IO-Link devices when replacing IO-Link devices. Check that the connected IO-Link device is an intended one, and review the connection or disable the IO-Link device validation setting to validate the IO-Link device after replacement.

The CQ LED indicates the result of IO-Link device validation. (☞ Page 117 Checking the LEDs)

## Description

The following table lists validation types and items to be validated.

○: Validated, ×: Not validated

Validation type	Validated item		
	Vendor ID	IO-Link device ID	Serial number
Disabled	×	×	×
Compatible	○	○	×
Identical	○	○	○

For this function, set the validation type for each channel on the parameter setting window of the engineering tool or via a program.

For confirmation of data to be read/written in transient communication (access code: 21H), set the validation type to either of the above to validate the device.

To apply changes of settings made in processing other than the initial processing and parameter setting on an engineering tool, turn on Operation condition setting request flag (RWw0.b9).

For details on setting parameters via a program, refer to the following.

☞ Page 87 Device validation

### Point

To use the IO-Link device validation function with "Initial operation setting" being set to "Without initial processing", set "Initial operation setting" to "Without initial processing" again after the device validation setting.

If not, the correct value is not stored.

For details on the initial operation setting, refer to the following.

☞ Page 80 Initial Operation Setting Function

☞ Page 84 Initial operation setting

## Preparation

When performing compatibility validation and identity validation, confirm the vendor ID, device ID, and serial number of the IO-Link device.

The following describes the procedure for confirming the vendor ID, device ID, and serial number of the IO-Link device.

**1.** Display the "Command Execution of Slave Station" window.

☞ From the list of stations, select an IO-Link module ⇒ [CC IE Field Configuration] ⇒ [Online] ⇒ [Command Execution of Slave Station].

**2.** Check the firmware version of the IO-Link module, and set "Method selection".

For the firmware version 2.0: "Detecting a device for V2.0"

For the firmware version 2.0.2 or later: "Detecting a device for V2.0.2 or later"

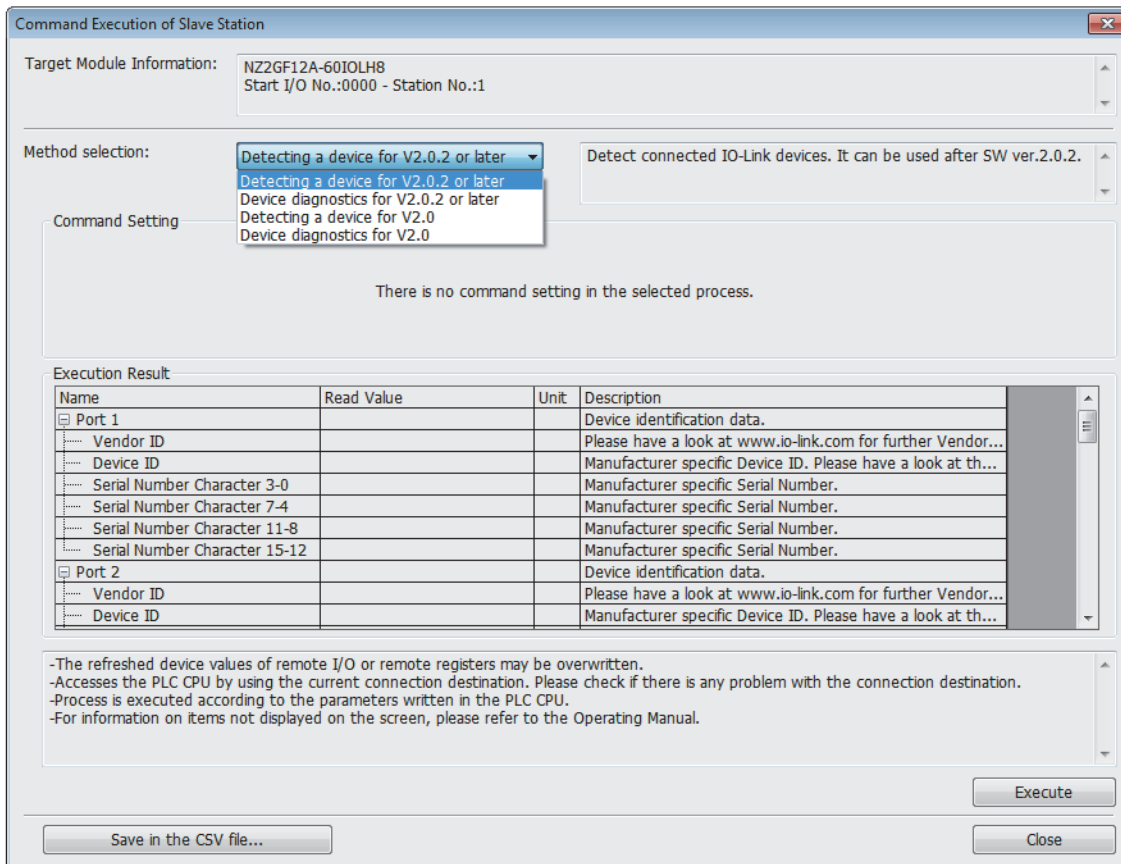

**3.** Click the "Execute" button.

## Setting procedure

**1.** Open the "CC IE Field Configuration" window.

For the master/local module RJ71GF11-T2

[Navigation window] ⇒ [Parameter] ⇒ [Module Information] ⇒ [RJ71GF11-T2] ⇒ [Module Parameter] ⇒ [Basic Settings] ⇒ [Network Configuration Settings]

**2.** Open the "Parameter Processing of Slave Station" window.

From the list of stations, select an IO-Link module ⇒ [CC IE Field Configuration] ⇒ [Online] ⇒ [Parameter Processing of Slave Station].

**3.** Set "Method selection" to "Parameter Write".



4. For each channel, set "Write Value" of "Validation setting".

Name	Initial Value	Unit	Read Value	Unit	Write Value	Unit	Setting Range	Description
<b>IO-Link parameter</b>								
<input checked="" type="checkbox"/> Channel 0 configuration setting								Set IO-Link chann
Process data size	1 word							Set process data s
Swap setting	Disable							Disable or enable v
Data storage setting	Disable							Disable or enable c
Validation setting	Disable							Set to disable, cor
Validation Vendor ID	0x0000	hex		hex		hex		Set vendor ID if va
Validation Device ID	0x00000000	hex		hex	Disable	hex		Set device ID if va
Serial Number Character 3-0	0x00000000	hex		hex	Compatible	hex		Set Serial number
Serial Number Character 7-4	0x00000000	hex		hex	Identical	hex		Set Serial number

Item	Setting range
Device validation setting	<ul style="list-style-type: none"> <li>• Disabled</li> <li>• Compatible</li> <li>• Identical</li> </ul>
Vendor ID	0000H to FFFFH <sup>*1,2</sup>
Device ID	00000000H to FFFFFFFFH <sup>*1,2</sup>
Serial number 1-4	00000000H to FFFFFFFFH <sup>*2</sup>
Serial number 5-8	00000000H to FFFFFFFFH <sup>*2</sup>
Serial number 9-12	00000000H to FFFFFFFFH <sup>*2</sup>
Serial number 13-16	00000000H to FFFFFFFFH <sup>*2</sup>

\*1 When the "Validation setting" is set to "Compatible", enter the vendor ID and device ID of the IO-Link device.

\*2 When the "Validation setting" is set to "Identical", enter the vendor ID, device ID, and serial number of the IO-Link device.

## Precautions

The following lists the availability of the combinations of the data storage setting and the device validation setting.

○: Available, ×: Not available

Data storage setting	Device validation setting		
	Disabled	Compatible	Identical
Disabled	○	○	○
Upload	× <sup>*1</sup>	○	○
Download	× <sup>*1</sup>	○	○
Upload/Download	× <sup>*1</sup>	○	○
Clear	○	○	○

\*1 When the settings are configured in an unavailable combination, operation of the IO-Link module may become unstable.

When the data storage setting is set to "Upload" or "Download", set the device validation setting to "Compatible" or "Identical".

## Disconnection detection function

---

This function detects disconnection if communication with an IO-Link device is lost in IO-Link mode.

Channel n communication start flag (RX30 to RX37) turns off if disconnection is detected.

For details, refer to the following.

 Page 134 Channel n communication start flag (RX30 to RX37)

### Setting procedure

---

This function is always enabled and parameter setting is not required.

# Swap function

This function swaps the upper and lower bytes of data sent and received between the IO-Link module and the IO-Link device connected to each channel.

With this function, there is no need to program an operation to swap the upper and lower bytes when using an IO-Link device that handles the upper and lower bytes in reverse.

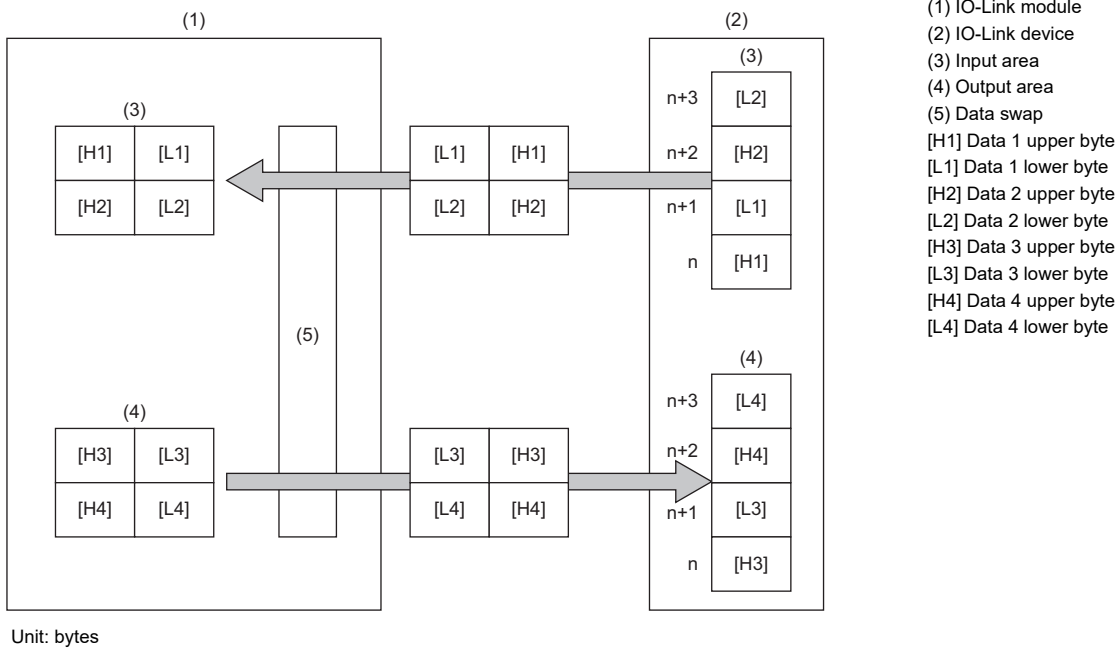

## Description

Enable or disable data swap for each channel using the parameter setting window of the engineering tool or via a program. Enable this function by enabling the seventh bit of the corresponding channel of the process data size (access code: 20H) of the data to be read or written in transient communication. (☞ Page 86 Process data size)

To apply the data swap setting changed in processing other than the initial processing, turn on Operation condition setting request flag (RWw0.b9).

For details on setting parameters via a program, refer to the following.

☞ Page 86 Process data size

## Setting procedure

1. Open the "CC IE Field Configuration" window.  
 For the master/local module RJ71GF11-T2  
 ☞ [Navigation window] ⇒ [Parameter] ⇒ [Module Information] ⇒ [RJ71GF11-T2] ⇒ [Module Parameter] ⇒ [Basic Settings] ⇒ [Network Configuration Settings]
2. Open the "Parameter Processing of Slave Station" window.  
 ☞ From the list of stations, select an IO-Link module ⇒ [CC IE Field Configuration] ⇒ [Online] ⇒ [Parameter Processing of Slave Station].
3. Set "Method selection" to "Parameter Write".

4. For each channel, set "Write Value" of "Swap setting".

Name	Initial Value	Unit	Read Value	Unit	Write Value	Unit	Setting Range	Description
<b>IO-Link parameter</b>								
<input checked="" type="checkbox"/> Channel 0 configuration setting								Set IO-Link chann
Process data size	1 word							Set process data s
Swap setting	Disable							Disable or enable v
Data storage setting	Disable							Disable or enable c
Validation setting	Disable							Set to disable, cor
Validation Vendor ID	0x0000	hex		hex		hex		Set vendor ID if v
Validation Device ID	0x00000000	hex		hex		hex		Set device ID if va
Serial Number Character 3-0	0x00000000	hex		hex		hex		Set Serial number
Serial Number Character 7-4	0x00000000	hex		hex		hex		Set Serial number

Item	Setting range
Swap setting	<ul style="list-style-type: none"> <li>• Disabled</li> <li>• Enabled</li> </ul>

## Precautions

Execute this function before operating external devices because the function should be enabled prior to communication.

# 7.2 SIO Mode Function

Channels 1 to 8 of the IO-Link module can be used for the IO-Link mode as well as the SIO mode where a maximum of 16 signals can be used.

For each channel, set either the IO-Link mode or SIO mode.

The default setting of each channel is the SIO mode input, but can be changed to the SIO mode input.

In the SIO mode, each channel works as the source type, therefore it cannot be used as the sink type.



For the operation of the IO-Link module that is disconnected from CC-Link IE Field Network during the SIO mode, refer to the following.

☞ Page 93 Output HOLD/CLEAR setting function

## SIO input function

The ON/OFF status (X signal) of inputs is notified to Remote input (RX) of the CC-Link IE Field Network.

To operate the SIO mode for inputs, turn off Channel n (CQ/Q) I/O switching command (RY10 to RY1F) in the initial processing.

To apply the I/O switching setting changed in processing other than the initial processing and parameter setting on an engineering tool, turn on Operation condition setting request flag (RWw0.b9).

### Setting procedure

1. Open the "CC IE Field Configuration" window.

For the master/local module RJ71GF11-T2

☞ [Navigation window] ⇒ [Parameter] ⇒ [Module Information] ⇒ [RJ71GF11-T2] ⇒ [Module Parameter] ⇒ [Basic Settings] ⇒ [Network Configuration Settings]

2. Open the "Parameter Processing of Slave Station" window.

☞ From the list of stations, select an IO-Link module ⇒ [CC IE Field Configuration] ⇒ [Online] ⇒ [Parameter Processing of Slave Station].

3. Set "Method selection" to "Parameter Write".

4. For each channel, set "Write Value" of "Pin configuration setting" to "INPUT".

Name	Initial Value	Unit	Read Value	Unit	Write Value	Unit	Setting Range	Description
<input checked="" type="checkbox"/> Pin configuration setting								Set the pin con
Configuration Port 1 CQ								The configurati
Configuration Port 1 Q								The configurati
Configuration Port 2 CQ								The configurati
Configuration Port 2 Q								The configurati
Configuration Port 3 CQ								The configurati
Configuration Port 3 Q								The configurati
Configuration Port 4 CQ								The configurati
Configuration Port 4 Q								The configurati
Configuration Port 5 CQ								The configurati

# SIO output function

The ON/OFF status (Y signal) of outputs is controlled with Remote output (RY) of the CC-Link IE Field Network.

To operate the SIO mode for outputs, turn on Channel n (CQ/Q) I/O switching command (RY10 to RY1F) in the initial processing.

To apply the I/O switching setting changed in processing other than the initial processing and parameter setting on an engineering tool, turn on Operation condition setting request flag (RWw0.b9).

## Setting procedure

1. Open the "CC IE Field Configuration" window.

For the master/local module RJ71GF11-T2

[Navigation window] ⇒ [Parameter] ⇒ [Module Information] ⇒ [RJ71GF11-T2] ⇒ [Module Parameter] ⇒ [Basic Settings] ⇒ [Network Configuration Settings]

2. Open the "Parameter Processing of Slave Station" window.

From the list of stations, select an IO-Link module ⇒ [CC IE Field Configuration] ⇒ [Online] ⇒ [Parameter Processing of Slave Station].

3. Set "Method selection" to "Parameter Write".

4. For each channel, set "Write Value" of "Pin configuration setting" to "OUTPUT".

Name	Initial Value	Unit	Read Value	Unit	Write Value	Unit	Setting Range	Description
Pin configuration setting								Set the pin con
Configuration Port 1 CQ								The configurati
Configuration Port 1 Q								The configurati
Configuration Port 2 CQ								The configurati
Configuration Port 2 Q								The configurati
Configuration Port 3 CQ								The configurati
Configuration Port 3 Q								The configurati
Configuration Port 4 CQ								The configurati
Configuration Port 4 Q								The configurati
Configuration Port 5 CQ								The configurati

# Number of SIO output ON times integration function

This function counts the number of SIO output ON times of each channel. (Range: 0 to 65535)

## Description

This function holds the integration value even if the IO-Link device is replaced, but it clears the integration value if the IO-Link module is powered off.

The integration value is reset to 0 to restart counting when it exceeds 65535.

### ■Reading the integration value

The integration value can be read from the parameter setting window of the engineering tool or the program.

For details on reading the integration value via a program, refer to the following.

Page 86 Number of ON times

### ■Resetting the integration value

The integration value can be reset by writing 0 from the parameter setting window of the engineering tool or the program.

## Setting procedure

1. Open the "CC IE Field Configuration" window.

For the master/local module RJ71GF11-T2

[Navigation window] ⇒ [Parameter] ⇒ [Module Information] ⇒ [RJ71GF11-T2] ⇒ [Module Parameter] ⇒ [Basic Settings] ⇒ [Network Configuration Settings]

2. Open the "Parameter Processing of Slave Station" window.

From the list of stations, select an IO-Link module ⇒ [CC IE Field Configuration] ⇒ [Online] ⇒ [Parameter Processing of Slave Station].

3. Set "Method selection" to "Parameter Write".

4. Set "Write Value" of "Number of ON times setting".

Name	Initial Value	Unit	Read Value	Unit	Write Value	Unit	Setting Range	Description
Basic module parameter								
<input checked="" type="checkbox"/> Number of ON times setting								Set the number o
Number of ON times Y0	0						0 to 65535	The total number
Number of ON times Y1	0						0 to 65535	The total number
Number of ON times Y2	0						0 to 65535	The total number
Number of ON times Y3	0						0 to 65535	The total number
Number of ON times Y4	0						0 to 65535	The total number
Number of ON times Y5	0						0 to 65535	The total number
Number of ON times Y6	0						0 to 65535	The total number
Number of ON times Y7	0						0 to 65535	The total number

Item	Setting range
Number of ON times Y0 to Number of ON times YF	0 to 65535

## Precautions

When the ON time and the OFF time of the output signal are less than 10ms, the IO-Link module cannot recognize the output change and the number of ON times may not be counted.

## 7.3 Power Supply Monitoring Function

This function checks the module/sensor power supply (US) voltage and the actuator power supply (UA) voltage, and notifies of the status when voltage drops.

The module/sensor power supply voltage must be normal to check the actuator power supply voltage properly.

### Description

If the module/sensor power supply voltage and actuator power supply voltage drop, the status can be checked with the remote input signal (RX) and the LED indication.

Type	Detection condition	Remote input signal	LED indication
Module/sensor power supply (US)	18V or less	The US voltage drop flag (18V or lower) (RX28) is ON.	The US LED is on in red.
Actuator power supply (UA)	18V or less	The UA voltage drop flag (18V or lower) (RX29) is ON.	The UA LED flashes in red.
	11V or less	The UA voltage drop flag (11V or lower) (RX2A) is ON.	The UA LED is on in red.

For details on the remote input signal (RX), refer to the following.

☞ Page 134 US voltage drop flag (18V or lower) (RX28)

☞ Page 134 UA voltage drop flag (18V or lower) (RX29)

☞ Page 134 UA voltage drop flag (11V or lower) (RX2A)

### Setting procedure

This function is always enabled and parameter setting is not required.



## 7.4 Short-Circuit Detection Function

This function detects a short-circuit in each channel to prevent overcurrent or an excessive temperature rise.

### Description

If the IO-Link module detects a short-circuit, the module performs the current limiter operation (that imposes a limit on the output current to a constant value and keeps the output).

If the load current becomes equal to the overcurrent detection value or lower, the module returns to normal operation.

#### ■ Judgment value for short-circuit detection

A short-circuit is detected per channel if the following conditions are met.

- L+ terminal: A short-circuit is detected if the output current is 1.6A or more.
- CQ and Q terminals: A short-circuit is detected if the output current is 3A or more.

#### ■ Notification of a detected short-circuit

If a short-circuit is detected, Channel n (CQ/Q) short-circuit detection flag (RX10 to RX1F) and Channel n (L+) short-circuit detection flag (RX20 to RX27) turn on.

For details on the remote input signal (RX), refer to the following.

☞ Page 132 Channel n (CQ/Q) short-circuit detection flag (RX10 to RX1F)

☞ Page 133 Channel n (L+) short-circuit detection flag (RX20 to RX27)

### Setting procedure

This function is always enabled and parameter setting is not required.

# 7.5 Initial Operation Setting Function

This function sets whether the initial processing using the program is necessary or not when the data link is established. The function enables the IO-Link module to operate (enabling the update of external I/O) with the program for initial processing not being set.

## Operation of the initial operation setting function

The operation of the initial operation setting function varies depending on the setting value of "Initial operation setting". When setting parameters using Initial processing request flag (RWr0.b8) as an interlock as shown in the program example, set "Initial operation setting" to "With initial processing".

For program examples of initial processing, refer to the following.

☞ Page 105 Program example

### ■When "With initial processing" is set

When the data link is established, Initial processing request flag (RWr0.b8) turns on.

When Initial processing completion flag (RwW0.b8) is turned on, Initial processing request flag (RWr0.b8) turns off and Remote READY (RWr0.b11) turns on.

The IO-Link module functions cannot be used until initial processing is completed.

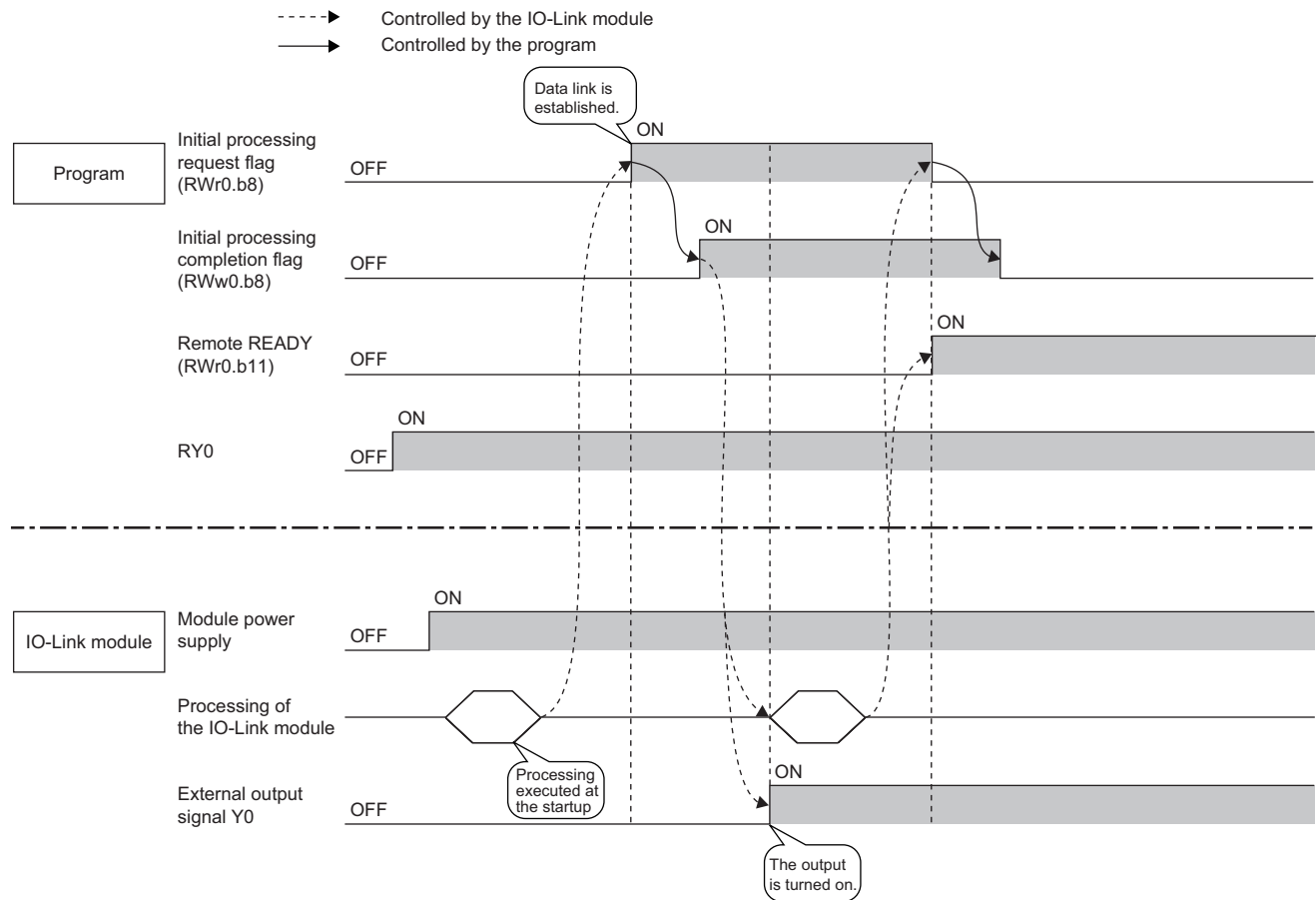

**When "Without initial processing" is set**

- When the data link is established, Remote READY (RWr0.b11) turns on.
- At the data link establishment, the functions of the IO-Link module become enabled.

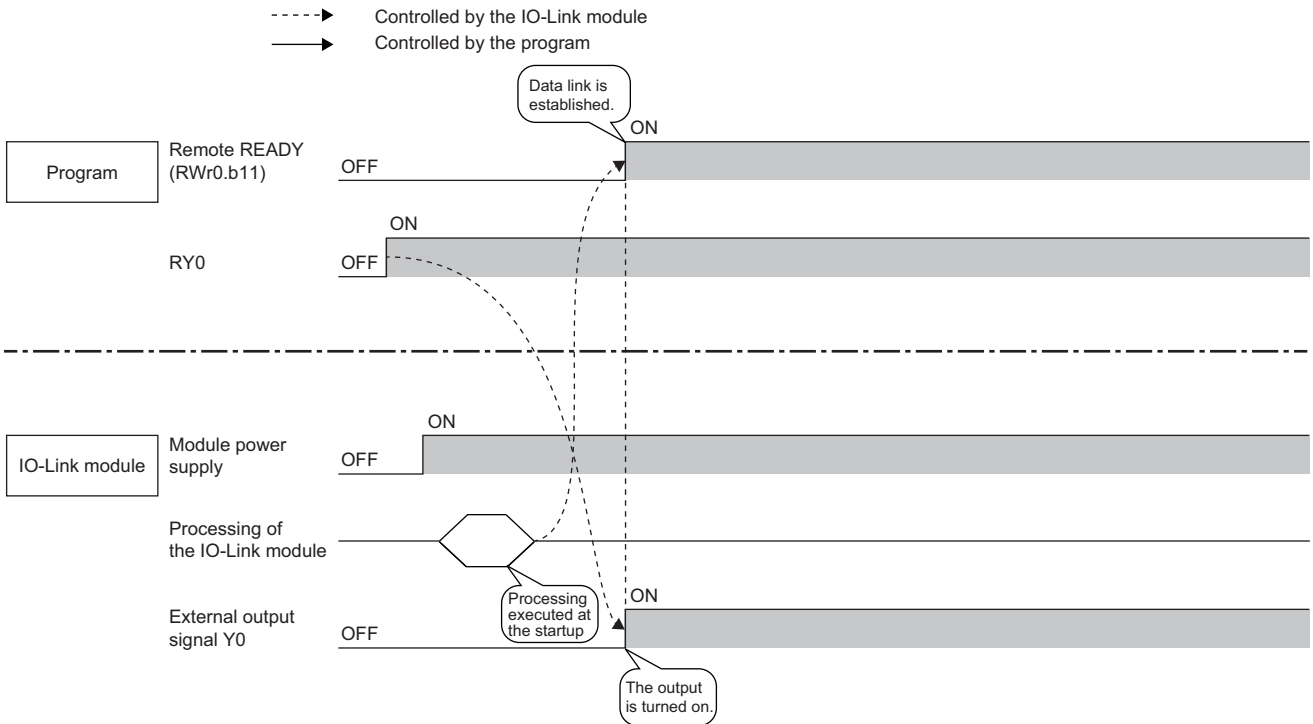

**Setting procedure**

1. Open the "CC IE Field Configuration" window.

For the master/local module RJ71GF11-T2

[Navigation window] ⇒ [Parameter] ⇒ [Module Information] ⇒ [RJ71GF11-T2] ⇒ [Module Parameter] ⇒ [Basic Settings] ⇒ [Network Configuration Settings]

2. Open the "Parameter Processing of Slave Station" window.

From the list of stations, select an IO-Link module ⇒ [CC IE Field Configuration] ⇒ [Online] ⇒ [Parameter Processing of Slave Station].

3. Set "Method selection" to "Parameter Write".

4. Set "Write Value" of "Initial operation setting".

Name	Initial Value	Unit	Read Value	Unit	Write Value	Unit	Setting Range	Description
<b>Station parameter</b>								
<input checked="" type="checkbox"/> Initial operation setting	With initial...							Set whether the
<input checked="" type="checkbox"/> Output HOLD/CLEAR setting	CLEAR							Set whether to h
<b>Basic module parameter</b>								
<input checked="" type="checkbox"/> Number of ON times setting								Set the number o
Number of ON times Y0	0						0 to 65535	The total number
Number of ON times Y1	0						0 to 65535	The total number
Number of ON times Y2	0						0 to 65535	The total number
Number of ON times Y3	0						0 to 65535	The total number
Number of ON times Y4	0						0 to 65535	The total number

Item	Setting range
Initial operation setting	<ul style="list-style-type: none"> <li>• With initial processing</li> <li>• Without initial processing</li> </ul>

# 7.6 CC-Link IE Field Network Communication Function

## Cyclic transmission

This function periodically exchanges data among stations on the network using link devices.

An IO-Link module operates as an intelligent device station on the CC-Link IE Field Network.

The status of the master station link devices (RY, RWw) is output to the IO-Link module external devices, and the status of input from the IO-Link module external devices are stored in the master station link devices (RX, RWr).

The following table lists applications of link devices used for the IO-Link module.

Link device	Application	Reference
RX, RY	Configures the settings such as the input and output values in IO-Link mode and SIO mode.	Page 129 Remote I/O Signals
RWw, RWr	Sets the initial processing, reads error codes, reads/writes IO-Link module process data.	Page 138 Remote Registers

For details on the CC-Link IE Field Network cyclic transmission, refer to the following.

 User's manual for the master/local module used

## Transient transmission

This function reads or writes data on the IO-Link module in line with a dedicated instruction from the master station. The IO-Link module uses the RIRD instruction or RIWT instruction to perform transient transmission.

### Data that can be read and written in transient transmission

The following table lists the IO-Link module data that can be read and written in transient transmission on the CC-Link IE Field Network.

Specify the access code, attribute code, and address code via the control data of the RIRD instruction or RIWT instruction. For details, refer to the following.

 User's manual for the master/local module used

 MELSEC iQ-R Programming Manual (Module Dedicated Instructions)

Data name	Access code	Attribute code	Address code <sup>*1</sup>	Description	Readable/Writable	Reference
IO-Link module identification data	10H	05H	10H to 17H	Read IO-Link module identification data.	Read	Page 84 IO-Link module identification data
Initial operation setting	11H	05H	00H	Enable/disable the initial processing when starting the IO-Link module.	Read/Write	Page 84 Initial operation setting
Output HOLD/CLEAR setting	12H	05H	00H	Configure the HOLD/CLEAR setting of the output value for cases where a communication error occurs.	Read/Write	Page 85 Output HOLD/CLEAR setting
Number of ON times	13H	05H	00H to 07H	Read the output ON times (count) in SIO mode.	Read/Write	Page 86 Number of ON times
Process data size	20H	05H	00H	Configure the swap setting and process data size for each channel.	Read/Write	Page 86 Process data size
Device validation	21H	05H	00H to 07H	Validates compatibility and identity of the IO-Link devices connected to the IO-Link module.	Read/Write	Page 87 Device validation
Data storage configuration	22H	05H	00H	Configure the data storage setting for each channel.	Read/Write	Page 88 Data storage configuration
Data storage content	24H	05H	00H to 07H	Read parameters in the data storage of each channel.	Read	Page 89 Data storage content
ISDU	30H	05H	00H to 07H	Read/write the IO-Link device parameters.	Read/Write	Page 92 ISDU
Event data	31H	05H	00H to 07H	Read event data that has occurred on the IO-Link devices.	Read	Page 92 Event data

\*1 The address code indicates the storage location of each data to be read or written.

## ■IO-Link module identification data

Read IO-Link module identification data.

Item	Description				
Access code	10H				
Attribute code	05H				
Address code	10H	11H	12H	13H	14H
Data size	1 to 56 bytes	1 to 56 bytes	1 to 56 bytes	1 to 56 bytes	1 to 56 bytes
Data*1	Manufacturer name	Manufacturer text	Product name	Product ID	Product text

\*1 Values are stored in alphanumeric ASCII code.

**Ex.**

The following table shows the identification data of the NZ2GF12A-60IOLH8 IO-Link module.

Address code	Stored value	Data size
10H	MITSUBISHI ELECTRIC CORPORATION	31 bytes
11H	<a href="http://www.MitsubishiElectric.co.jp/fa/">http://www.MitsubishiElectric.co.jp/fa/</a>	39 bytes
12H	NZ2GF12A-60IOLH8	16 bytes
13H	105	3 bytes
14H	IO-Link master module	21 bytes

**Point**

IO-Link module identification data is not writable. An error occurs in the RIWT instruction if the write is attempted.

## ■Initial operation setting

Enable/disable the initial processing when starting the IO-Link module.

- With initial processing: Initial processing request flag (RWr0.b8) is turned off and on at power-on and initial processing is executed. When the initial processing is complete, the IO-Link module starts operation.
- Without initial processing: Initial processing is not executed at power-on, and the IO-Link module starts operation with the default settings.

Item	Description
Access code	11H
Attribute code	05H
Address code	00H
Data size	2 bytes
Data	<ul style="list-style-type: none"> <li>• 0000H: With initial processing</li> <li>• 0001H: Without initial processing</li> </ul> (Default: 0000H)

For details on the initial operation setting, refer to the following.

☞ Page 140 Initial processing request flag (RWr0.b8)

## ■Output HOLD/CLEAR setting

Configure the HOLD/CLEAR setting of the output value. If a communication error occurs, the output is held or cleared.

During IO-Link mode

- HOLD: The output process data remains valid even after a communication error occurs.
- CLEAR: The output process data immediately before occurrence of a communication error becomes invalid.\*1

\*1 The operation of the IO-Link device when the output process data is invalid varies depending on the IO-Link device connected. For details, refer to the manual of the IO-Link device.

During SIO mode

- HOLD: Holds each output status even if a communication error occurs.
- CLEAR: Clears each of previous output status if a communication error occurs.

Item	Description
Access code	12H
Attribute code	05H
Address code	00H
Data size	2 bytes
Data	<ul style="list-style-type: none"><li>• 0000H: CLEAR</li><li>• 0001H: HOLD</li></ul> (Default: 0000H)

For details on the output HOLD/CLEAR setting, refer to the following.

 Page 93 Output HOLD/CLEAR setting function

## ■Number of ON times

Read the output ON times (count) in SIO mode.

To reset the integration value, write 0000H.

Item	Description
Access code	13H
Attribute code	05H
Address code	00H to 07H (corresponding to channel numbers 1 to 8)
Data size	4 bytes
Data	<ul style="list-style-type: none"> <li>• First and second bytes: The output ON times integration value of the CQ terminal (0 to 65535) (Default: 0000H)</li> <li>• Third and fourth bytes: The output ON times integration value of the Q terminal (0 to 65535) (Default: 0000H)</li> </ul>

The output ON times integration value is reset to 0 to restart counting when it exceeds 65535.

For details on the output ON times integration value, refer to the following.

☞ Page 77 Number of SIO output ON times integration function

### Ex.

When the output ON times integration value is read from the device connected to channel 1 when the Q terminal of the output port is turned on five times, 0005H is stored in the third and fourth bytes.

## ■Process data size

Configure the swap setting and process data size for each channel.

For the process data size, specify the number of words not less than the process data size of the IO-Link device used. (If the IO-Link device controls 3-byte process data, set the process data size to two words (4 bytes) or more.)

Item	Description
Access code	20H
Attribute code	05H
Address code	00H
Data size	8 bytes
Data	<ul style="list-style-type: none"> <li>• First byte: The swap setting and process data size of the IO-Link module channel 1 (Default: 01H)</li> <li>• Second byte: The swap setting and process data size of the IO-Link module channel 2 (Default: 01H)</li> <li>• Third byte: The swap setting and process data size of the IO-Link module channel 3 (Default: 01H)</li> <li>• Fourth byte: The swap setting and process data size of the IO-Link module channel 4 (Default: 01H)</li> <li>• Fifth byte: The swap setting and process data size of the IO-Link module channel 5 (Default: 01H)</li> <li>• Sixth byte: The swap setting and process data size of the IO-Link module channel 6 (Default: 01H)</li> <li>• Seventh byte: The swap setting and process data size of the IO-Link module channel 7 (Default: 01H)</li> <li>• Eighth byte: The swap setting and process data size of the IO-Link module channel 8 (Default: 01H)</li> </ul>

The following table shows the swap setting and process data size of each channel.

Data configuration	Description
b0 to b4	Process data size (1 to 16) (Unit: words)
B5, b6	Use prohibited (fixed to 0)
b7	Swap setting (0: Disabled, 1: Enabled)

- Process data size: Specify the number of words for the process data size.
- Swap setting: Enable/disable the swap function.

For details on the swap function, refer to the following.

☞ Page 73 Swap function



## ■ Device validation

Validates compatibility and identity of the IO-Link devices connected to the IO-Link module.

Specify any of the following for the validation type in the first byte. Information of the connected IO-Link device is stored in the third and subsequent bytes.

- 00H: Disabled
- 01H: Compatibility validation
- 02H: Identity validation

Item	Description
Access code	21H
Attribute code	05H
Address code	00H to 07H (corresponding to channel numbers 1 to 8)
Data size	24 bytes
Data* <sup>1</sup>	<ul style="list-style-type: none"><li>• First byte: Validation type (Default: 00H)</li><li>• Second byte: Use prohibited (fixed to 0)</li><li>• Third byte: Vendor ID (upper) (Default: 00H)<sup>*2</sup></li><li>• Fourth byte: Vendor ID (lower) (Default: 00H)<sup>*2</sup></li><li>• Fifth byte: Device ID (upper) (Default: 00H)<sup>*2</sup></li><li>• Sixth byte: Device ID (Default: 00H)<sup>*2</sup></li><li>• Seventh byte: Device ID (lower) (Default: 00H)<sup>*2</sup></li><li>• Eighth byte: Use prohibited (fixed to 0)</li><li>• 9th to 24th byte: Serial numbers 1 to 16 (Default: 00H)</li></ul>

\*1 For details on each data, refer to the manual of the IO-Link device used.

\*2 Write the vendor ID and device ID in the big endian format.

For details on the IO-Link device validation function, refer to the following.

 Page 69 IO-Link device validation function

## ■ Data storage configuration

Configure the data storage setting for each channel.

The data storage is the area in which the IO-Link device parameters are stored, and is used by the IO-Link device setting automatic upload/download function.

Item	Description
Access code	22H
Attribute code	05H
Address code	00H
Data size	8 bytes
Data	<ul style="list-style-type: none"><li>• First byte: The data storage configuration of the IO-Link module channel 1 (Default: 00H)</li><li>• Second byte: The data storage configuration of the IO-Link module channel 2 (Default: 00H)</li><li>• Third byte: The data storage configuration of the IO-Link module channel 3 (Default: 00H)</li><li>• Fourth byte: The data storage configuration of the IO-Link module channel 4 (Default: 00H)</li><li>• Fifth byte: The data storage configuration of the IO-Link module channel 5 (Default: 00H)</li><li>• Sixth byte: The data storage configuration of the IO-Link module channel 6 (Default: 00H)</li><li>• Seventh byte: The data storage configuration of the IO-Link module channel 7 (Default: 00H)</li><li>• Eighth byte: The data storage configuration of the IO-Link module channel 8 (Default: 00H)</li></ul>

The following table shows the data storage configuration and data configuration of each channel.

Data configuration	Description
b0	Upload setting (0: Disabled, 1: Enabled)
b1	Download setting (0: Disabled, 1: Enabled)
b2 to b5	Use prohibited (fixed to 0)
b6	Data storage deletion request (0: Not delete, 1: Delete)
b7	Data storage configuration (0: Disabled, 1: Enabled)

- **Upload setting**
  - Enabled: Parameters of each IO-Link device parameters are uploaded to the data storage of the IO-Link module.
  - Disabled: Parameters of each IO-Link device are not uploaded. However, if there is no parameters in the data storage of the IO-Link module, the IO-Link device parameters are uploaded.
- **Download setting**
  - Enabled: Parameters in the data storage of the IO-Link module are downloaded to each IO-Link device.
  - Disabled: Parameters in the data storage of the IO-Link module are not downloaded.
- **Data storage deletion request**
  - Delete: Parameters saved in the data storage of the IO-Link module are deleted.
  - Not delete: Parameters saved in the data storage of the IO-Link module are not deleted.
- **Data storage configuration**
  - Enabled: Parameters are saved in the data storage of the IO-Link module.
  - Disabled: Parameters are not saved in the data storage of the IO-Link module. However, if parameters already exist in the data storage, the parameters are not deleted even if this setting is disabled.



Enable the Data storage configuration when the Upload setting and Download setting are enabled. It is not possible to enable only the Data storage configuration.

Disable the Data storage configuration when the Data storage deletion request is enabled.

## ■Data storage content

Read parameters in the data storage of each channel.

The following table show the parameter configuration.

<Receive data configuration>

Index (lower byte) + index (upper byte) + subindex + parameter length (bytes) + parameter

Address code: 0H to 7H	
Item	Description
Access code	24H
Attribute code	05H
Address code	00H to 07H (corresponding to channel numbers 1 to 8)
Data size	684 bytes
Data	1st to 684th bytes: Data storage saved in the IO-Link module (Default: 00H)

Address code: 10H to 17H	
Item	Description
Access code	24H
Attribute code	05H
Address code	10H to 17H (corresponding to channel numbers 1 to 8)
Data size	684 bytes
Data	685th to 1368th bytes: Data storage saved in the IO-Link module (Default: 00H)

Address code: 20H to 27H	
Item	Description
Access code	24H
Attribute code	05H
Address code	20H to 27H (corresponding to channel numbers 1 to 8)
Data size	680 bytes
Data	1369th to 2048th bytes: Data storage saved in the IO-Link module (Default: 00H)



Data storage content is not writable. An error occurs in the RIWT instruction if the write is attempted.

**Ex.**

The following describes the data storage configuration the channel 1 parameters (four parameters).

■ Parameter configuration

Word	Upper byte	Lower byte		
1st word	Index (upper byte)	Index (lower byte)		
2nd word	Parameter length	Subindex		
3rd word	Parameter (example: 2 bytes)			
4th word	Index (upper byte)	Index (lower byte)		
5th word	Parameter length	Subindex		
6th word	Parameter (example: 32 bytes)			
7th word				
8th word				
9th word				
10th word				
11th word				
12th word	Parameter (example: 32 bytes)			
13th word				
14th word				
15th word				
16th word				
17th word				
18th word	Parameter (example: 32 bytes)			
19th word				
20th word				
21st word				
22nd word			Index (upper byte)	Index (lower byte)
23rd word			Parameter length	Subindex
24th word	Index (lower byte)	Parameter (example: 1 bytes)		
25th word	Subindex	Index (upper byte)		
26th word	Parameter (example: 1 bytes)	Parameter length		

- (1) Channel 1 parameter data storage content (1)
- (2) Channel 1 parameter data storage content (2)
- (3) Channel 1 parameter data storage content (3)
- (4) Channel 1 parameter data storage content (4)

## ■ Sample data

Word	Upper byte								Lower byte								Value
	b15	b14	b13	b12	b11	b10	b9	b8	b7	b6	b5	b4	b3	b2	b1	b0	
1st word	0	0	0	0	0	0	0	0	0	0	0	0	1	1	0	0	000CH
2nd word	0	0	0	0	0	0	0	1	0	0	0	0	0	0	0	0	0200H
3rd word	0	0	0	0	0	0	0	0	0	0	0	0	0	0	0	0	0000H
4th word	0	0	0	0	0	0	0	0	0	0	0	1	1	0	0	0	0018H
5th word	0	0	1	0	0	0	0	0	0	0	0	0	0	0	0	0	2000H
6th word	0	0	0	0	0	0	0	0	0	0	0	0	0	0	0	0	0000H
7th word	0	0	0	0	0	0	0	0	0	0	0	0	0	0	0	0	0000H
8th word	0	0	0	0	0	0	0	0	0	0	0	0	0	0	0	0	0000H
9th word	0	0	0	0	0	0	0	0	0	0	0	0	0	0	0	0	0000H
10th word	0	0	0	0	0	0	0	0	0	0	0	0	0	0	0	0	0000H
11th word	0	0	0	0	0	0	0	0	0	0	0	0	0	0	0	0	0000H
12th word	0	0	0	0	0	0	0	0	0	0	0	0	0	0	0	0	0000H
13th word	0	0	0	0	0	0	0	0	0	0	0	0	0	0	0	0	0000H
14th word	0	0	0	0	0	0	0	0	0	0	0	0	0	0	0	0	0000H
15th word	0	0	0	0	0	0	0	0	0	0	0	0	0	0	0	0	0000H
16th word	0	0	0	0	0	0	0	0	0	0	0	0	0	0	0	0	0000H
17th word	0	0	0	0	0	0	0	0	0	0	0	0	0	0	0	0	0000H
18th word	0	0	0	0	0	0	0	0	0	0	0	0	0	0	0	0	0000H
19th word	0	0	0	0	0	0	0	0	0	0	0	0	0	0	0	0	0000H
20th word	0	0	0	0	0	0	0	0	0	0	0	0	0	0	0	0	0000H
21st word	0	0	0	0	0	0	0	0	0	0	0	0	0	0	0	0	0000H
22nd word	0	0	0	0	0	0	0	0	0	0	1	0	0	0	0	0	0040H
23rd word	0	0	0	0	0	0	0	0	1	0	0	0	0	0	0	0	0100H
24th word	0	1	0	0	0	0	0	0	1	0	0	0	0	0	0	1	4102H
25th word	0	0	0	0	0	0	0	0	0	0	0	0	0	0	0	0	0000H
26th word	0	0	0	0	0	0	1	0	0	0	0	0	0	0	0	1	0201H

## ■ Data content

Item	Value	
Channel 1 parameter data storage content (1)	Index (lower byte)	0CH
	Index (upper byte)	00H
	Subindex	00H
	Parameter length	02H
	Parameter	00H × 2 bytes
Channel 1 parameter data storage content (2)	Index (lower byte)	18H
	Index (upper byte)	00H
	Subindex	00H
	Parameter length	20H
	Parameter	00H × 32 bytes
Channel 1 parameter data storage content (3)	Index (lower byte)	40H
	Index (upper byte)	00H
	Subindex	00H
	Parameter length	01H
	Parameter	02H × 1 bytes
Channel 1 parameter data storage content (4)	Index (lower byte)	41H
	Index (upper byte)	00H
	Subindex	00H
	Parameter length	01H
	Parameter	02H × 1 bytes

## ■ISDU

Read/write the IO-Link device parameters.

Use indexes, subindexes, and control data for the read and write operations. Specify data values relevant to the connected IO-Link device.

Item	Description
Access code	30H
Attribute code	05H
Address code	00H to 07H (corresponding to channel numbers 1 to 8)
Data size	4 to 236 bytes
Data	<ul style="list-style-type: none"><li>• First byte: Index (lower) (Default: 00H)</li><li>• Second byte: Index (upper) (Default: 00H)</li><li>• Third byte: Subindex (Default: 00H)</li><li>• Fourth byte: Control data (Default: 00H)</li><li>• 5th to 236th byte: Request/response data (Default: 00H)</li></ul>

The control data content is as follows.

- Parameter read: 01H
- Parameter write (request/response data is odd number of bytes): 80H
- Parameter write (request/response data is even number of bytes): 00H

### Point

- An error will occur if the control data value is set out of the valid range. (  Page 126 List of Error Codes and the Warning Codes)
- Execute the RIWT instruction before executing the RIRD instruction when reading parameters. For setting data of the RIWT instruction, specify the data size (4 bytes), index, subindex, and control data (01H). Execute the RIWT instruction and then the RIRD instruction to read parameters. For setting data of the RIRD instruction, specify the data size (4 bytes + response data size).

## ■Event data

Read event data that has occurred on the IO-Link devices.

If an event occurs on the connected IO-Link device, the corresponding bit of Channel n event flag (RX38 to RX3F) turns off and on.

When all the events that have occurred are read, Channel n event flag (RX38 to RX3F) turns on and off.

Item	Description
Access code	31H
Attribute code	05H
Address code	00H to 07H (corresponding to channel numbers 1 to 8)
Data size	4 bytes
Data	<ul style="list-style-type: none"><li>• First byte: Event identifier</li><li>• Second byte: Use prohibited (fixed to 0)</li><li>• Third byte: Event code (lower)</li><li>• Fourth byte: Event code (upper)</li></ul>

For content of an event read, refer to the manual of the IO-Link device used.

### Point

Event data is not writable. An error occurs in the RIWT instruction if the write is attempted.

# Output HOLD/CLEAR setting function

This function sets the handling of the last output data when the IO-Link module is disconnected from data link or when the CPU module is in the STOP state, RESET state, or ERROR STOP state. The operation of the IO-Link module varies depending on whether the module is in the IO-Link mode or the SIO mode.

## Output HOLD/CLEAR setting and its operation

When CLEAR or HOLD is set for an output, the output is turned on or off as follows.

### ■When IO-Link mode is set

Operating status		Output HOLD/CLEAR setting	
		CLEAR	HOLD
Data link in operation	CPU module in RUN	Data valid	Data valid
	CPU module in STOP	Data invalid	Data valid
	CPU module in PAUSE	Data valid	Data valid
	CPU module in RESET	Data invalid	Data held
	CPU module suspended by error	Data invalid	Data valid
During disconnection/cyclic stop		Data invalid	Data held

The operation of the IO-Link device of which output HOLD/CLEAR setting is set to CLEAR varies depending on the IO-Link device connected. For details, refer to the manual of the IO-Link device.

### Restriction

The output HOLD/CLEAR setting function cannot be used on the IO-Link module of which firmware version is "2.0". In this case, the IO-Link module operates based on the HOLD setting.

### ■When SIO mode is set

- HOLD: Outputs the last output data.
- CLEAR: Outputs OFF.

To set HOLD or CLEAR to all output process data collectively, set the output HOLD/CLEAR setting of the data to be read or written via transient communication.

Operating status		HOLD/CLEAR setting CLEAR (default)		HOLD/CLEAR setting HOLD	
		Last output status OFF	Last output status ON	Last output status OFF	Last output status ON
Data link in operation	CPU module in RUN	OFF	ON	OFF	ON
	CPU module in STOP	OFF	ON/OFF*1	OFF	ON/OFF*1
	CPU module in PAUSE	OFF	ON	OFF	ON
	CPU module in RESET	OFF	OFF	OFF	ON
	CPU module suspended by error	OFF	ON/OFF*1	OFF	ON/OFF*1
During disconnection/cyclic stop		OFF	OFF	OFF	ON

\*1 The output ON/OFF status is subject to the parameter settings (the output mode setting upon CPU error, output hold/clear setting upon CPU STOP) of the master/local module.

### Point

The external input signal (RX) and external output signal (RY) will be turned off regardless of this setting if a moderate or major error occurs on the IO-Link module.

## Setting procedure

1. Open the "CC IE Field Configuration" window.

For the master/local module RJ71GF11-T2

[Navigation window] ⇒ [Parameter] ⇒ [Module Information] ⇒ [RJ71GF11-T2] ⇒ [Module Parameter] ⇒ [Basic Settings] ⇒ [Network Configuration Settings]

2. Open the "Parameter Processing of Slave Station" window.

From the list of stations, select an IO-Link module ⇒ [CC IE Field Configuration] ⇒ [Online] ⇒ [Parameter Processing of Slave Station].

3. Set "Method selection" to "Parameter Write".

4. Set "Write Value" of "Output HOLD/CLEAR setting".

Name	Initial Value	Unit	Read Value	Unit	Write Value	Unit	Setting Range	Description
<b>Station parameter</b>								
<input checked="" type="checkbox"/>	Initial operation setting	With initial...						Set whether the initial processing using the p
<input checked="" type="checkbox"/>	Output HOLD/CLEAR setting	CLEAR						If a communication error occurs in SIO mode,
<b>Basic module parameter</b>								
<input checked="" type="checkbox"/>	Number of ON times setting				CLEAR HOLD			Set the number of ON times.
	Number of ON times Y0	0					0 to 65535	The total number of ON times of each output
	Number of ON times Y1	0					0 to 65535	The total number of ON times of each output
	Number of ON times Y2	0					0 to 65535	The total number of ON times of each output
	Number of ON times Y3	0					0 to 65535	The total number of ON times of each output
	Number of ON times Y4	0					0 to 65535	The total number of ON times of each output
	Number of ON times Y5	0					0 to 65535	The total number of ON times of each output

Item	Setting range
Output HOLD/CLEAR setting	<ul style="list-style-type: none"> <li>• CLEAR</li> <li>• HOLD</li> </ul>



# CC-Link IE Field Network diagnostics

This function allows the presence or absence of a network error to be checked by accessing the engineering tool connected to the CPU module.

## How to use

The following instructions assume the use of GX Works3 as the engineering tool.

1. Connect GX Works3 to the CPU module.
2. Start CC-Link IE Field Network diagnostics from the menu of GX Works3.

 [Diagnostics] ⇒ [CC IE Field Diagnostics]

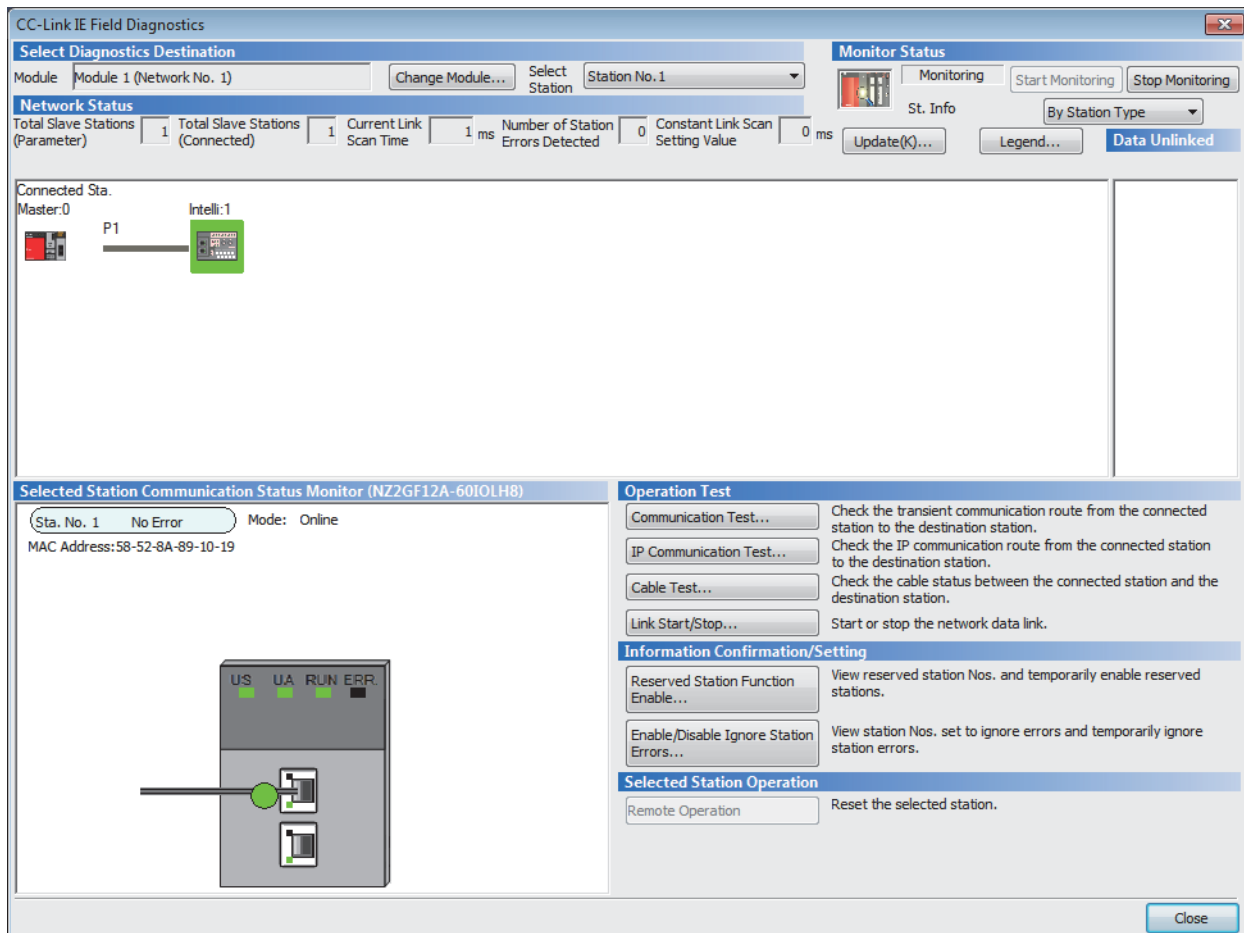

Items to be diagnosed on the IO-Link module are as follows.

Item to be diagnosed		Description	Reference
Display of the network map and error status		The status of the CC-Link IE Field Network can be checked. When an error or a warning occurs on the IO-Link module, the status of the station is displayed on an icon.	User's manual for the master/local module used
Operation Test	Communication Test	The transient communication route and whether the communication is established from the connected station to the destination station can be checked.	
	Cable Test	The cable status between the connected station and the destination station can be checked.	
	Link Start/Stop	The network data link can be started or stopped.	
Information Confirmation/Setting	Reserved Station Function Enable	Temporary cancel of the reserved station setting can be enabled or disabled. Also, the station numbers of the modules set as reserved stations can be checked on a list.	

## Precautions

The temporary error invalid station cannot be set by clicking the [Enable/Disable Ignore Station Errors]. The IO-Link module does not operate even when this button is clicked.

# 8 MODULE FUNCTION BLOCKS

This chapter describes module function blocks.

Using the module function blocks reduces a load of the user programming and improves the readability of the program.

## Module function blocks

Module function block is POU that can be used with GX Works3.

For details, refer to the following.

Manual name	Manual number
CC-Link IE Field Network Waterproof Remote IO-Link Module Function Block Reference (For MELSEC iQ-R)	BCN-P5999-0989

# MEMO

---

# 9 PROGRAMMING

This chapter describes the programming of the IO-Link module.

## 9.1 Precautions for Programming

This section describes precautions to create CC-Link IE Field Network programs.

### Cyclic transmission program

For a cyclic transmission program, interlock with the following link special relay (SB) and link special register (SW).

- Own station data link status (master station) (SB0049)
- Data link status (each station) (SW00B0 to SW00B7)

For details on the link special relay (SB) and link special register (SW), refer to the user's manual for the master/local module used.

**Ex.**

Interlock example

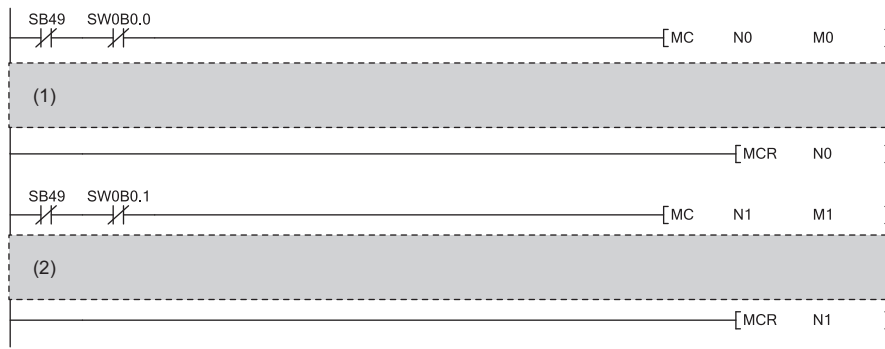

- (1) Communication program with station No.1
- (2) Communication program with station No.2

### Transient transmission program

For a transient transmission program, interlock with the following link special relay (SB) and link special register (SW).

- Own station baton pass status (master station) (SB0047)
- Baton pass status (each station) (SW00A0 to SW00A7)

For details on the link special relay (SB) and link special register (SW), refer to the user's manual for the master/local module used.

**Ex.**

Interlock example



- (1) Start contact
- (2) Dedicated instruction to station No.1

## Program with initial processing

The IO-Link module reads and writes data in transient transmission with initial processing enabled or disabled in the initial operation setting. (☞ Page 84 Initial operation setting)

With initial processing enabled, the IO-Link module does not operate after power-on until the initial processing is complete. Be sure to check that Remote READY (RWr0.b11) is on after the initial processing is complete.

## 9.2 Program Example of Setting Parameters Using a Dedicated Instruction

The following describes a program example to set parameters using a dedicated instruction of the master/local module.

### System configuration example

#### ■ System configuration

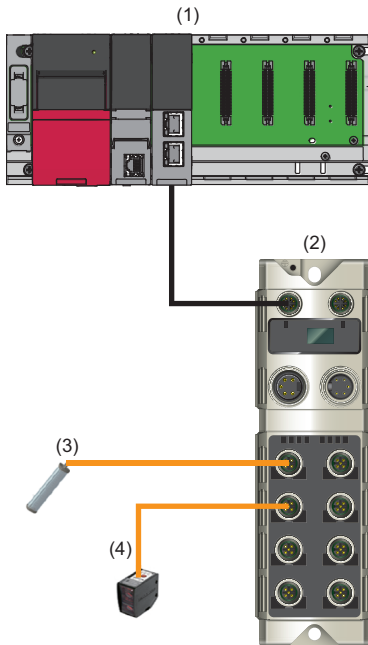

- (1) Master station (network No.1, station No.0)
  - Power supply module: R61P
  - CPU module: R04CPU
  - CC-Link IE Field Network master/local module: RJ71GF11-T2  
(Start I/O number: 0000H to 001FH)
- (2) Slave station (network No.1, station No.1)
  - IO-Link module: NZ2GF12A-60IOLH8
- (3) Smart light (channel 1)
- (4) Photoelectric distance sensor (channel 2)

## ■Assignment of link devices

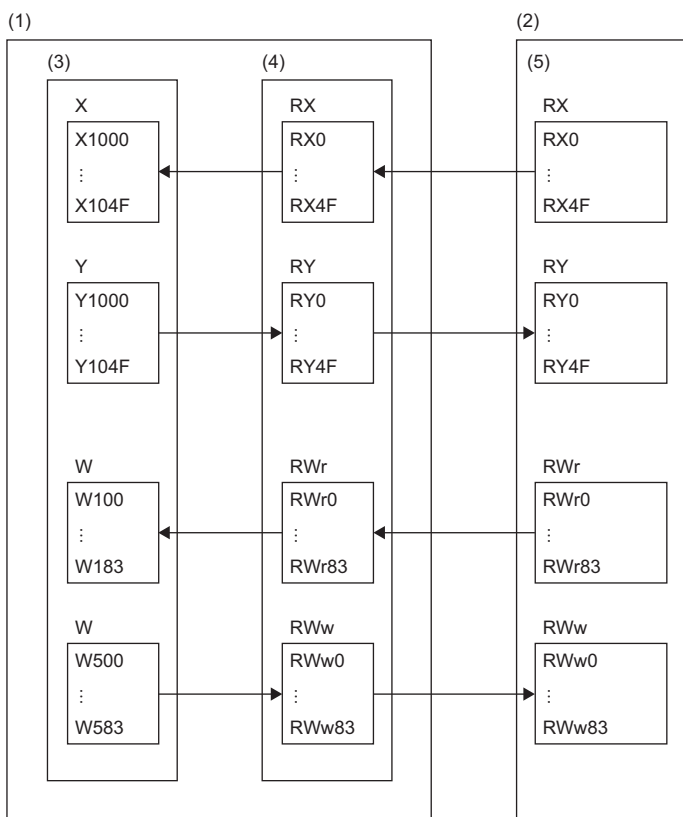

(1) CC-Link IE Field Network master station

(2) CC-Link IE Field Network slave station

(3) CPU module

(4) Master/local module

(5) IO-Link module



## Configuring the parameters

Connect an engineering tool to the CPU module and set parameters.

1. Configure the CPU module in the following way.

 [Project] ⇒ [New]

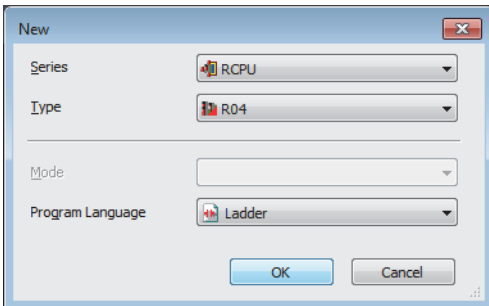

2. Click [OK] button on the following window to add a module label of the CPU module.

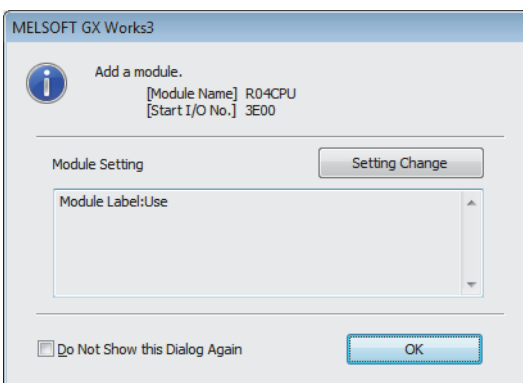

3. Configure the CC-Link IE Field Network master/local module in the following way.

 [Navigation window] ⇒ [Parameter] ⇒ [Module Information] ⇒ Right-click ⇒ [Add New Module]

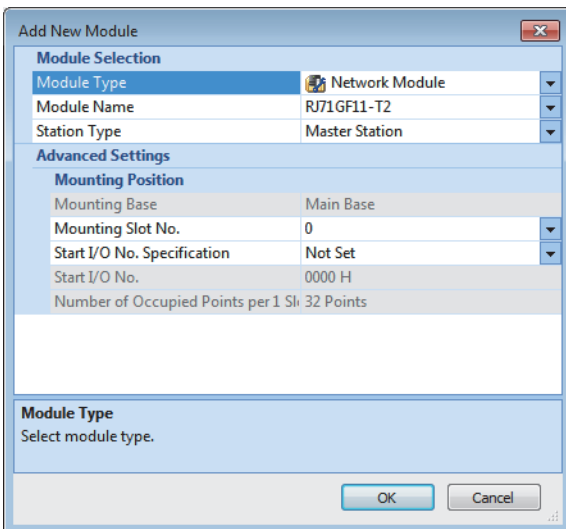

4. Click [OK] button on the following window to add a module label of the CC-Link IE Field Network master/local module.

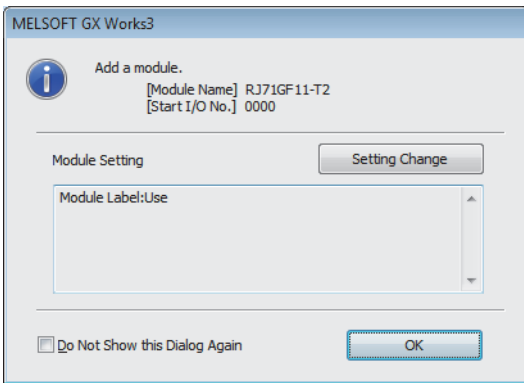

5. Configure "Required Settings" of "Module Parameter" in the following way.

[Navigation window] ⇒ [Parameter] ⇒ [Module Information] ⇒ [RJ71GF11-T2] ⇒ [Module Parameter] ⇒ [Required Settings]

Item	Setting
<b>Station Type</b>	
Station Type	Master Station
<b>Network No.</b>	
Network No.	1
<b>Station No.</b>	
Setting Method	Parameter Editor
Station No.	0
<b>Parameter Setting Method</b>	
Setting Method of Basic/Application Settings	Parameter Editor

6. Configure the network in the following way.

[Navigation window] ⇒ [Parameter] ⇒ [Module Information] ⇒ [RJ71GF11-T2] ⇒ [Module Parameter] ⇒ [Basic Settings] ⇒ [Network Configuration Settings]

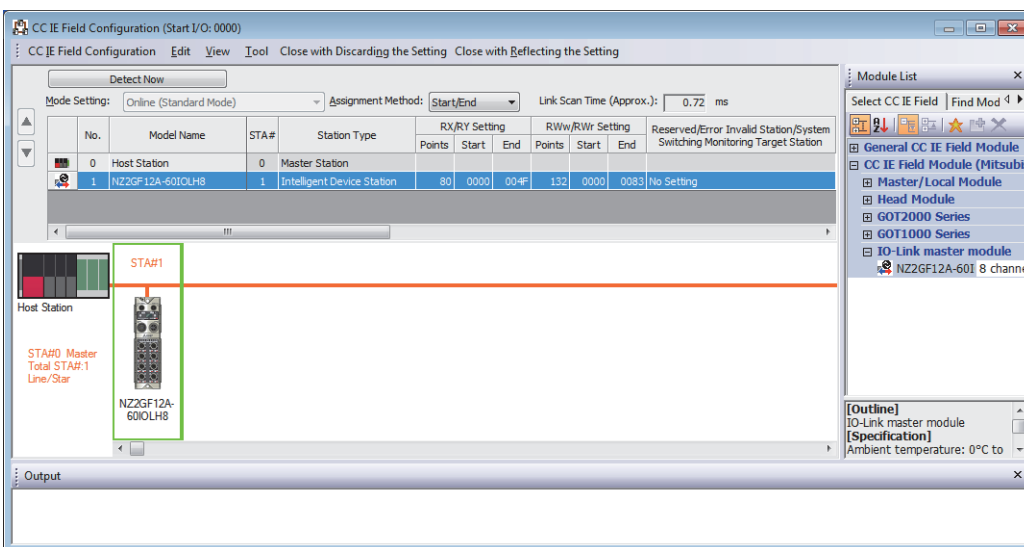







7. Close the "CC IE Field Configuration" window.

[CC IE Field Configuration] ⇒ [Close with Reflecting the Setting]

8. Display the refresh parameter setting window and configure the setting as follows.

 [Navigation window] ⇒ [Parameter] ⇒ [Module Information] ⇒ [RJ71GF11-T2] ⇒ [Module Parameter] ⇒ [Basic Settings]  
⇒ [Refresh Settings]

No.	Link Side					CPU Side				
	Device Name	Points	Start	End		Target	Device Name	Points	Start	End
-	SB	512	00000	001FF		Specify Device	SB	512	00000	001FF
-	SW	512	00000	001FF		Specify Device	SW	512	00000	001FF
1	RX	80	00000	0004F		Specify Device	X	80	01000	0104F
2	RY	80	00000	0004F		Specify Device	Y	80	01000	0104F
3	RWr	132	00000	00083		Specify Device	W	132	00100	00183
4	RWw	132	00000	00083		Specify Device	W	132	00500	00583

9. Write the set parameter to the CPU module of the master station and reset the CPU module, or turn off and on the power supply.

 [Online] ⇒ [Write to PLC]

### Point

In this example, default settings are used for parameters other than the above. For details on parameters, refer to the following.

 Page 45 Parameter Setting

 User's manual for the master/local module used

## Checking the network status

When the parameters are set, check that the data link status is normal.

The following table lists the IO-Link module LED indications for normal communications.

LED	Status
RUN LED	On
ERR. LED	Off
UA LED	Green
US LED	Green
LINK LED(P1)	On
L ER LED(P1)	Green

## Program example

Classification	Label name	Description	Device
Module label	GF11_1.bSts_DataLinkError	Own station data link error status	SB0049
	GF11_1.bnSts_DataLinkError_Station[1]	Data link status (each station) (station No.1)	SW00B0.0

Classification	Label name	Description	Device																																																																																																																																																												
Defined labels	Define global labels as follows.																																																																																																																																																														
	<table border="1"> <thead> <tr> <th>Label Name</th> <th>Data Type</th> <th>Class</th> <th>Assign (Device/Label)</th> </tr> </thead> <tbody> <tr><td>IOLinkCH1to8</td><td>Word [Signed]</td><td>VAR_GLOBAL</td><td>K4Y1030</td></tr> <tr><td>InitialRequest</td><td>Bit</td><td>VAR_GLOBAL</td><td>W100.8</td></tr> <tr><td>READY</td><td>Bit</td><td>VAR_GLOBAL</td><td>W100.8</td></tr> <tr><td>InitialCompletion</td><td>Bit</td><td>VAR_GLOBAL</td><td>W500.8</td></tr> <tr><td>bHandShake</td><td>Bit</td><td>VAR_GLOBAL</td><td>M0</td></tr> <tr><td>bRIWTCompletion</td><td>Bit(0..1)</td><td>VAR_GLOBAL</td><td>M1</td></tr> <tr><td>bCommunicationFlag1</td><td>Bit</td><td>VAR_GLOBAL</td><td>M10</td></tr> <tr><td>bCData</td><td>Bit</td><td>VAR_GLOBAL</td><td>M11</td></tr> <tr><td>bRIWTOOutputActivation</td><td>Bit</td><td>VAR_GLOBAL</td><td>M12</td></tr> <tr><td>bInitialActivation</td><td>Bit</td><td>VAR_GLOBAL</td><td>M13</td></tr> <tr><td>blni1</td><td>Bit</td><td>VAR_GLOBAL</td><td>M14</td></tr> <tr><td>blni2</td><td>Bit</td><td>VAR_GLOBAL</td><td>M15</td></tr> <tr><td>bOutputActivation</td><td>Bit</td><td>VAR_GLOBAL</td><td>M16</td></tr> <tr><td>uRIWTstatus</td><td>Word [Signed]</td><td>VAR_GLOBAL</td><td>D300</td></tr> <tr><td>uStationNumber</td><td>Word [Signed]</td><td>VAR_GLOBAL</td><td>D301</td></tr> <tr><td>uAccessCode</td><td>Word [Signed]</td><td>VAR_GLOBAL</td><td>D302</td></tr> <tr><td>uAddressCode</td><td>Word [Signed]</td><td>VAR_GLOBAL</td><td>D303</td></tr> <tr><td>uDataSize</td><td>Word [Signed]</td><td>VAR_GLOBAL</td><td>D304</td></tr> <tr><td>uWriteData1</td><td>Word [Signed]</td><td>VAR_GLOBAL</td><td>D310</td></tr> <tr><td>uWriteData2</td><td>Word [Signed]</td><td>VAR_GLOBAL</td><td>D311</td></tr> <tr><td>uWriteData3</td><td>Word [Signed]</td><td>VAR_GLOBAL</td><td>D312</td></tr> <tr><td>uWriteData4</td><td>Word [Signed]</td><td>VAR_GLOBAL</td><td>D313</td></tr> <tr><td>uRIWTError</td><td>Word [Signed]</td><td>VAR_GLOBAL</td><td>D200</td></tr> <tr><td>ulData1CH2</td><td>Word [Signed]</td><td>VAR_GLOBAL</td><td>W114</td></tr> <tr><td>ulData2CH2</td><td>Word [Signed]</td><td>VAR_GLOBAL</td><td>W115</td></tr> <tr><td>LaserErr</td><td>Bit</td><td>VAR_GLOBAL</td><td>W114.A</td></tr> <tr><td>uOUTData1</td><td>Word [Signed]</td><td>VAR_GLOBAL</td><td>W504</td></tr> <tr><td>uOUTData2</td><td>Bit</td><td>VAR_GLOBAL</td><td>W514.0</td></tr> <tr><td>SaveData1</td><td>Word [Signed]</td><td>VAR_GLOBAL</td><td>K4M100</td></tr> <tr><td>SaveData2</td><td>Word [Signed]</td><td>VAR_GLOBAL</td><td>K4M120</td></tr> <tr><td>SaveData3</td><td>Word [Signed]</td><td>VAR_GLOBAL</td><td>K2M128</td></tr> <tr><td>SaveData4</td><td>Word [Signed]</td><td>VAR_GLOBAL</td><td>K2M140</td></tr> <tr><td>SaveData5</td><td>Word [Signed]</td><td>VAR_GLOBAL</td><td>K2M148</td></tr> <tr><td>SaveData6</td><td>Word [Signed]</td><td>VAR_GLOBAL</td><td>K4M140</td></tr> <tr><td>SaveData7</td><td>Word [Signed]</td><td>VAR_GLOBAL</td><td>K2M100</td></tr> <tr><td>uResultsData</td><td>Word [Signed]</td><td>VAR_GLOBAL</td><td>D0</td></tr> <tr><td>bTimerStart</td><td>Bit</td><td>VAR_GLOBAL</td><td>M17</td></tr> <tr><td>Timer1</td><td>Timer</td><td>VAR_GLOBAL</td><td>T0</td></tr> </tbody> </table>	Label Name	Data Type	Class	Assign (Device/Label)	IOLinkCH1to8	Word [Signed]	VAR_GLOBAL	K4Y1030	InitialRequest	Bit	VAR_GLOBAL	W100.8	READY	Bit	VAR_GLOBAL	W100.8	InitialCompletion	Bit	VAR_GLOBAL	W500.8	bHandShake	Bit	VAR_GLOBAL	M0	bRIWTCompletion	Bit(0..1)	VAR_GLOBAL	M1	bCommunicationFlag1	Bit	VAR_GLOBAL	M10	bCData	Bit	VAR_GLOBAL	M11	bRIWTOOutputActivation	Bit	VAR_GLOBAL	M12	bInitialActivation	Bit	VAR_GLOBAL	M13	blni1	Bit	VAR_GLOBAL	M14	blni2	Bit	VAR_GLOBAL	M15	bOutputActivation	Bit	VAR_GLOBAL	M16	uRIWTstatus	Word [Signed]	VAR_GLOBAL	D300	uStationNumber	Word [Signed]	VAR_GLOBAL	D301	uAccessCode	Word [Signed]	VAR_GLOBAL	D302	uAddressCode	Word [Signed]	VAR_GLOBAL	D303	uDataSize	Word [Signed]	VAR_GLOBAL	D304	uWriteData1	Word [Signed]	VAR_GLOBAL	D310	uWriteData2	Word [Signed]	VAR_GLOBAL	D311	uWriteData3	Word [Signed]	VAR_GLOBAL	D312	uWriteData4	Word [Signed]	VAR_GLOBAL	D313	uRIWTError	Word [Signed]	VAR_GLOBAL	D200	ulData1CH2	Word [Signed]	VAR_GLOBAL	W114	ulData2CH2	Word [Signed]	VAR_GLOBAL	W115	LaserErr	Bit	VAR_GLOBAL	W114.A	uOUTData1	Word [Signed]	VAR_GLOBAL	W504	uOUTData2	Bit	VAR_GLOBAL	W514.0	SaveData1	Word [Signed]	VAR_GLOBAL	K4M100	SaveData2	Word [Signed]	VAR_GLOBAL	K4M120	SaveData3	Word [Signed]	VAR_GLOBAL	K2M128	SaveData4	Word [Signed]	VAR_GLOBAL	K2M140	SaveData5	Word [Signed]	VAR_GLOBAL	K2M148	SaveData6	Word [Signed]	VAR_GLOBAL	K4M140	SaveData7	Word [Signed]	VAR_GLOBAL	K2M100	uResultsData	Word [Signed]	VAR_GLOBAL	D0	bTimerStart	Bit	VAR_GLOBAL	M17	Timer1	Timer	VAR_GLOBAL	T0		
Label Name	Data Type	Class	Assign (Device/Label)																																																																																																																																																												
IOLinkCH1to8	Word [Signed]	VAR_GLOBAL	K4Y1030																																																																																																																																																												
InitialRequest	Bit	VAR_GLOBAL	W100.8																																																																																																																																																												
READY	Bit	VAR_GLOBAL	W100.8																																																																																																																																																												
InitialCompletion	Bit	VAR_GLOBAL	W500.8																																																																																																																																																												
bHandShake	Bit	VAR_GLOBAL	M0																																																																																																																																																												
bRIWTCompletion	Bit(0..1)	VAR_GLOBAL	M1																																																																																																																																																												
bCommunicationFlag1	Bit	VAR_GLOBAL	M10																																																																																																																																																												
bCData	Bit	VAR_GLOBAL	M11																																																																																																																																																												
bRIWTOOutputActivation	Bit	VAR_GLOBAL	M12																																																																																																																																																												
bInitialActivation	Bit	VAR_GLOBAL	M13																																																																																																																																																												
blni1	Bit	VAR_GLOBAL	M14																																																																																																																																																												
blni2	Bit	VAR_GLOBAL	M15																																																																																																																																																												
bOutputActivation	Bit	VAR_GLOBAL	M16																																																																																																																																																												
uRIWTstatus	Word [Signed]	VAR_GLOBAL	D300																																																																																																																																																												
uStationNumber	Word [Signed]	VAR_GLOBAL	D301																																																																																																																																																												
uAccessCode	Word [Signed]	VAR_GLOBAL	D302																																																																																																																																																												
uAddressCode	Word [Signed]	VAR_GLOBAL	D303																																																																																																																																																												
uDataSize	Word [Signed]	VAR_GLOBAL	D304																																																																																																																																																												
uWriteData1	Word [Signed]	VAR_GLOBAL	D310																																																																																																																																																												
uWriteData2	Word [Signed]	VAR_GLOBAL	D311																																																																																																																																																												
uWriteData3	Word [Signed]	VAR_GLOBAL	D312																																																																																																																																																												
uWriteData4	Word [Signed]	VAR_GLOBAL	D313																																																																																																																																																												
uRIWTError	Word [Signed]	VAR_GLOBAL	D200																																																																																																																																																												
ulData1CH2	Word [Signed]	VAR_GLOBAL	W114																																																																																																																																																												
ulData2CH2	Word [Signed]	VAR_GLOBAL	W115																																																																																																																																																												
LaserErr	Bit	VAR_GLOBAL	W114.A																																																																																																																																																												
uOUTData1	Word [Signed]	VAR_GLOBAL	W504																																																																																																																																																												
uOUTData2	Bit	VAR_GLOBAL	W514.0																																																																																																																																																												
SaveData1	Word [Signed]	VAR_GLOBAL	K4M100																																																																																																																																																												
SaveData2	Word [Signed]	VAR_GLOBAL	K4M120																																																																																																																																																												
SaveData3	Word [Signed]	VAR_GLOBAL	K2M128																																																																																																																																																												
SaveData4	Word [Signed]	VAR_GLOBAL	K2M140																																																																																																																																																												
SaveData5	Word [Signed]	VAR_GLOBAL	K2M148																																																																																																																																																												
SaveData6	Word [Signed]	VAR_GLOBAL	K4M140																																																																																																																																																												
SaveData7	Word [Signed]	VAR_GLOBAL	K2M100																																																																																																																																																												
uResultsData	Word [Signed]	VAR_GLOBAL	D0																																																																																																																																																												
bTimerStart	Bit	VAR_GLOBAL	M17																																																																																																																																																												
Timer1	Timer	VAR_GLOBAL	T0																																																																																																																																																												

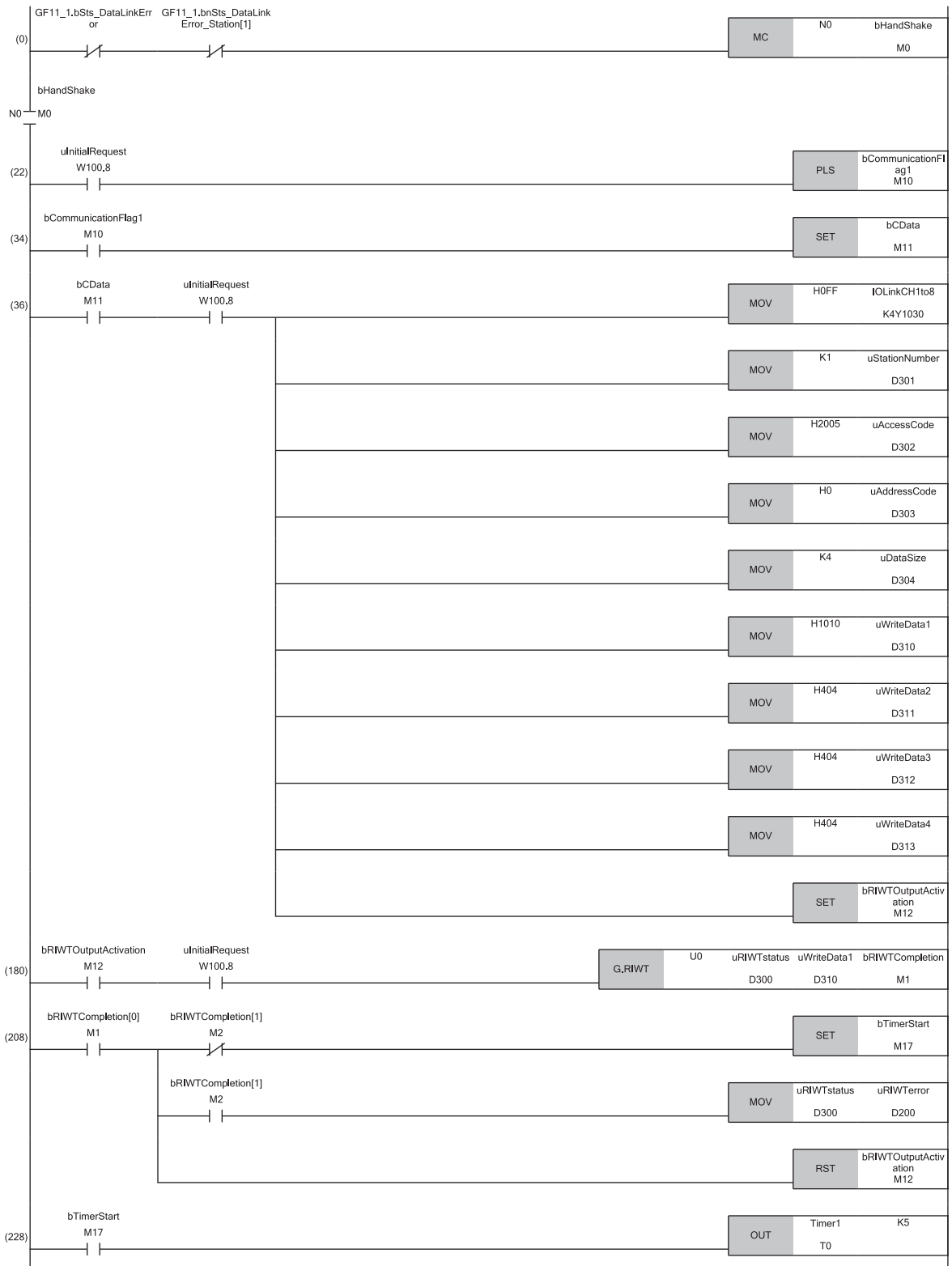

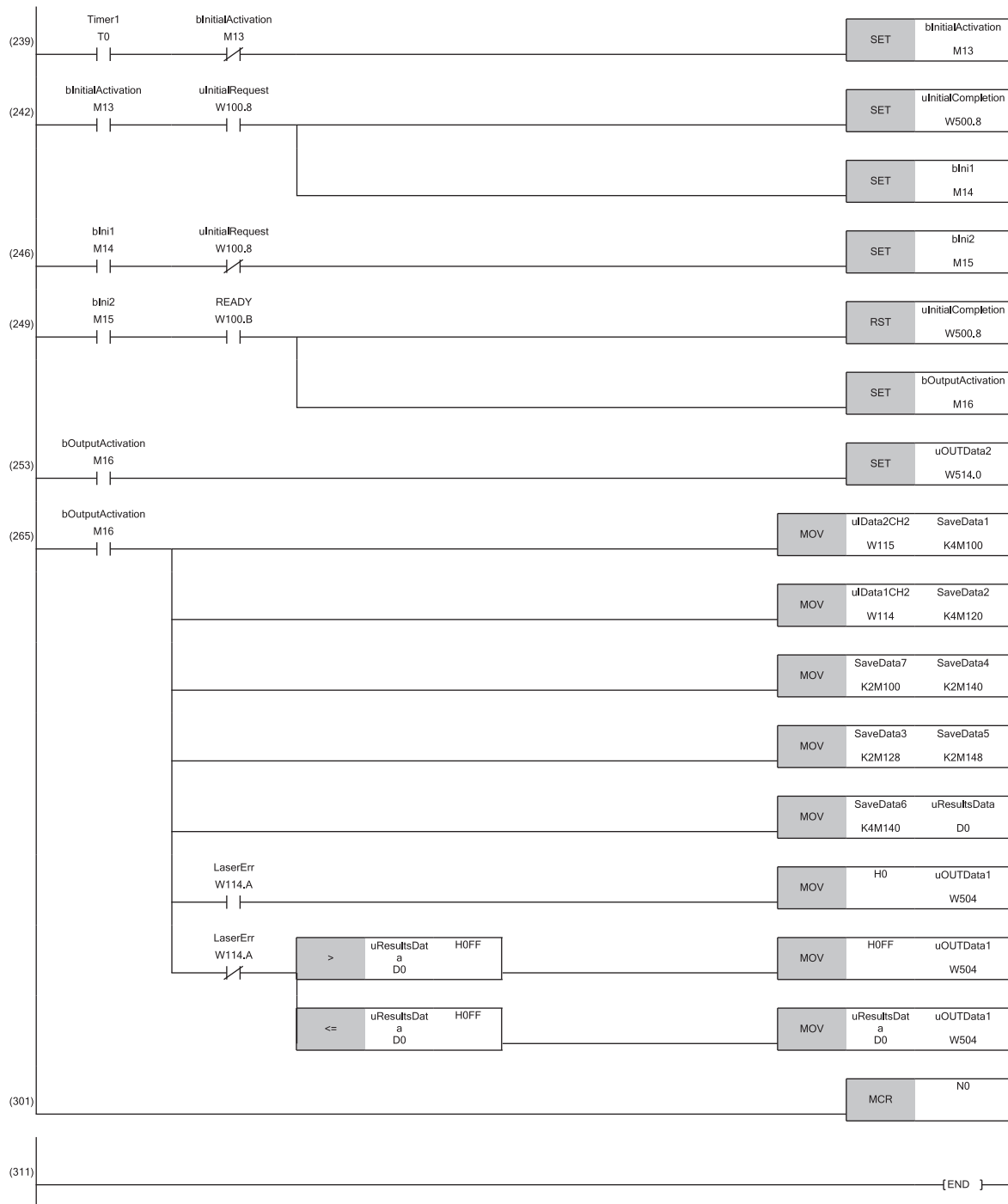

- (0) Check the data link status of station No.1.
- (22) Turn on the initial processing flag to configure the initial settings.
- (36) Store control data of RIWT instruction.
- (180) Use an RIWT instruction to set IO-Link module parameters.

## 9.3 Example of Program to Communicate with an IO-Link Device

The following describes an example of a program that communicates with IO-Link devices by using functions of the IO-Link module.

### System configuration example

For details on system configuration, refer to the following.

☞ Page 101 System configuration example

### Initial setting description

The following table lists the initial settings of the IO-Link module.

Item <sup>*1</sup>	Description	
Initial operation setting	Without initial processing	
Output HOLD/CLEAR setting	CLEAR	
Pin configuration setting	Channel 1 CQ setting	IO-Link mode
	Channel 1 Q setting	Input
	Channel 2 CQ setting	IO-Link mode
	Channel 2 Q setting	Input
IO-Link parameters (Channel 1 setting)	Process data size	16 words
	Swap setting	Disable
	Data storage configuration	Disable
	Validation setting	Disable
IO-Link parameters (Channel 2 setting)	Process data size	16 words
	Swap setting	Disable
	Data storage configuration	Disable
	Validation setting	Disable

\*1 Configure settings of channels 3 to 8 as well because any parameter write setting item must not be left blank.

### Configuring the parameters

Connect an engineering tool to the CPU module and set parameters.

**1.** Configure the CPU module in the following way.

☞ [Project] ⇒ [New]

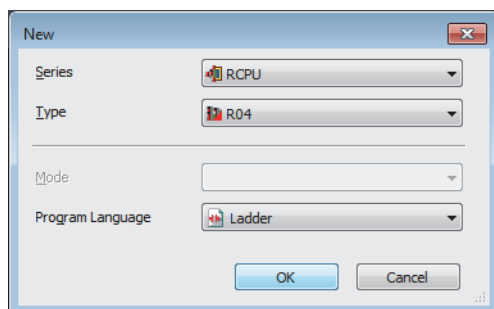

2. Click [OK] button on the following window to add a module label of the CPU module.

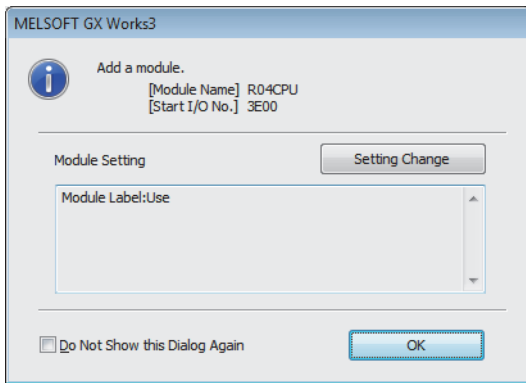

3. Configure the CC-Link IE Field Network master/local module in the following way.

[Navigation window] ⇒ [Parameter] ⇒ [Module Information] ⇒ Right-click ⇒ [Add New Module]

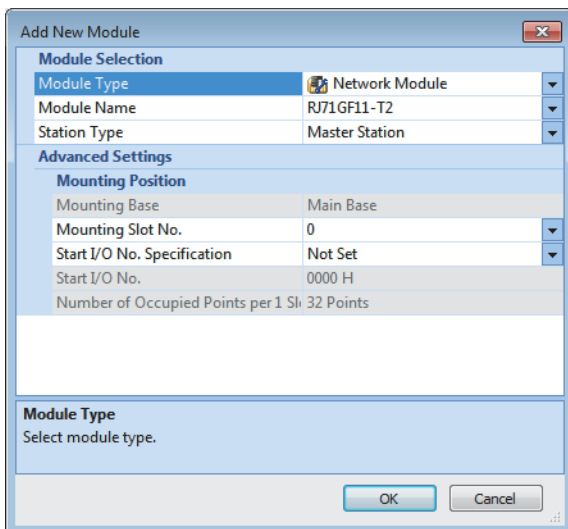

4. Click [OK] button on the following window to add a module label of the CC-Link IE Field Network master/local module.

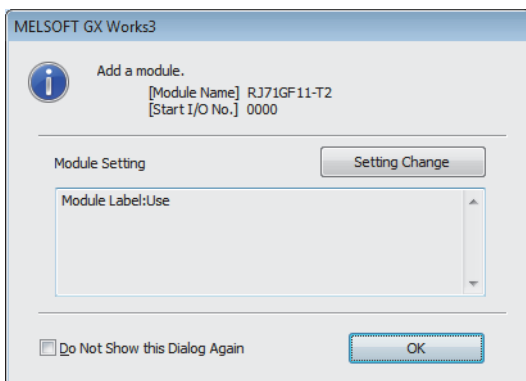

5. Configure "Required Settings" of "Module Parameter" in the following way.

[Navigation window] ⇒ [Parameter] ⇒ [Module Information] ⇒ [RJ71GF11-T2] ⇒ [Module Parameter] ⇒ [Required Settings]

Item	Setting
<b>Station Type</b>	
Station Type	Master Station
<b>Network No.</b>	
Network No.	1
<b>Station No.</b>	
Setting Method	Parameter Editor
Station No.	0
<b>Parameter Setting Method</b>	
Setting Method of Basic/Application Settings	Parameter Editor



**6.** Configure the network in the following way.

[Navigation window] ⇒ [Parameter] ⇒ [Module Information] ⇒ [RJ71GF11-T2] ⇒ [Module Parameter] ⇒ [Basic Settings]  
⇒ [Network Configuration Settings]

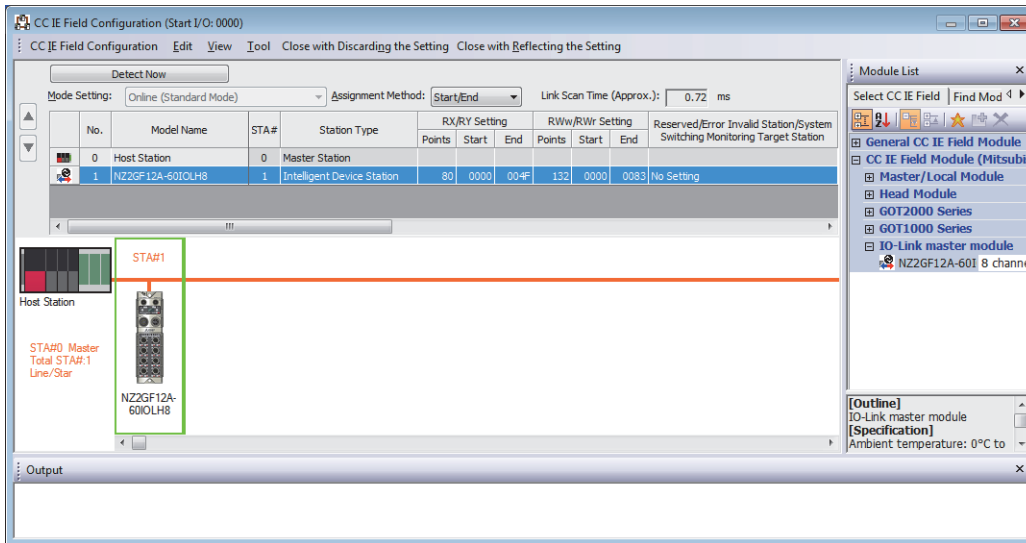

**7.** Display the "Parameter Processing of Slave Station" window.

From the list of stations, select an IO-Link module ⇒ [CC IE Field Configuration] ⇒ [Online] ⇒ [Parameter Processing of Slave Station].

**8.** Set "Method selection" to "Parameter Write".

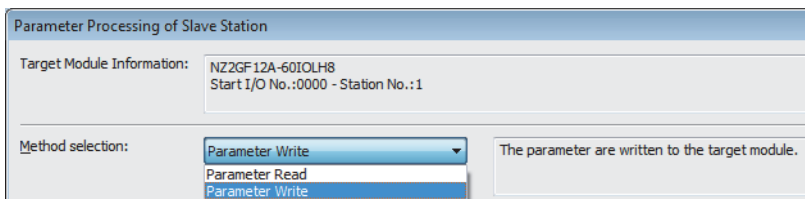

**9.** Set "Write Value". The following are the procedure.

- Click the title cell of "Initial Value" to select all the items and copy them.
- Click the title cell of "Write Value" to select all the items and paste the copy.
- Select the items to be changed, and set new values according to Initial setting description. (☞ Page 109 Initial setting description)

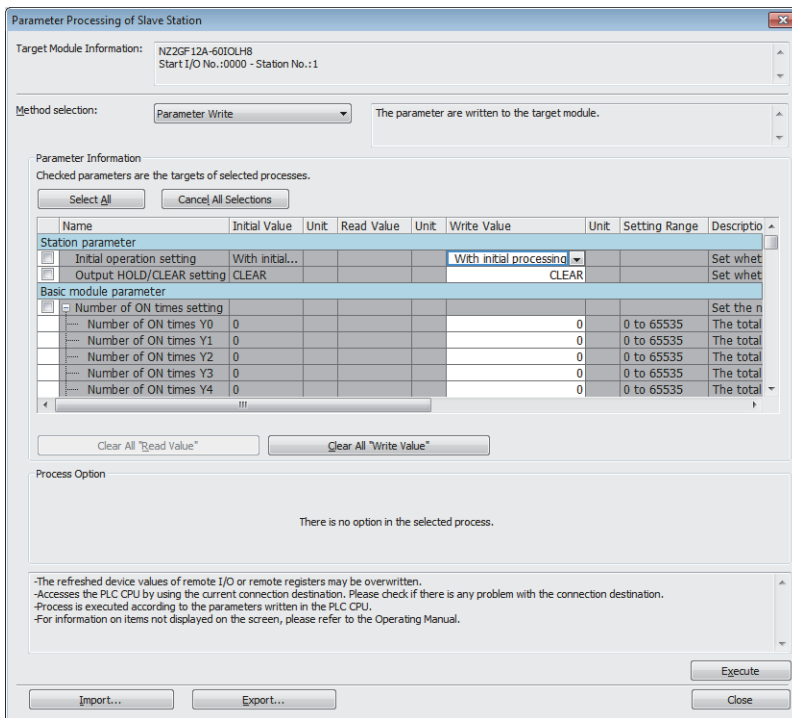

**10.** Click the [Execute] button to write the parameter to the IO-Link module.

**11.** Close the "CC IE Field Configuration" window.

☞ [CC IE Field Configuration] ⇒ [Close with Reflecting the Setting]

**12.** Display the refresh parameter setting window and configure the setting as follows.

☞ [Navigation window] ⇒ [Parameter] ⇒ [Module Information] ⇒ [RJ71GF11-T2] ⇒ [Module Parameter] ⇒ [Basic Settings] ⇒ [Refresh Settings]

No.	Link Side					CPU Side				
	Device Name	Points	Start	End		Target	Device Name	Points	Start	End
-	SB	512	00000	001FF	↔	Specify Device	SB	512	00000	001FF
-	SW	512	00000	001FF	↔	Specify Device	SW	512	00000	001FF
1	RX	80	00000	0004F	↔	Specify Device	X	80	01000	0104F
2	RY	80	00000	0004F	↔	Specify Device	Y	80	01000	0104F
3	RWr	132	00000	00083	↔	Specify Device	W	132	00100	00183
4	RWw	132	00000	00083	↔	Specify Device	W	132	00500	00583

**13.** Write the set parameter to the CPU module of the master station and reset the CPU module, or turn off and on the power supply.

☞ [Online] ⇒ [Write to PLC]



In this example, default settings are used for parameters other than the above. For details on parameters, refer to the following.

☞ Page 45 Parameter Setting

📖 User's manual for the master/local module used

## Checking the network status

When the parameters are set, check that the data link status is normal.

The following table lists the IO-Link module LED indications for normal communications.

LED	Status
RUN LED	On
ERR. LED	Off
UA LED	Green
US LED	Green
LINK LED(P1)	On
LER LED(P1)	Green

## Program example

Classification	Label name	Description	Device	
Module label	GF11_1.bSts_DataLinkError	Own station data link error status	SB0049	
	GF11_1.bnSts_DataLinkError_Station[1]	Data link status (each station) (station No.1)	SW00B0.0	
Defined labels	Define global labels as follows.			
	Label Name	Data Type	Class	Assign (Device/Label)
	READY	Bit	VAR_GLOBAL	W100.B
	bHandShake	Bit	VAR_GLOBAL	M0
	ulData1CH2	Word [Signed]	VAR_GLOBAL	W114
	ulData2CH2	Word [Signed]	VAR_GLOBAL	W115
	lLaserErr	Bit	VAR_GLOBAL	W114.A
	uOUTData1	Word [Signed]	VAR_GLOBAL	W504
	uOUTData2	Bit	VAR_GLOBAL	W514.0
	bOutputActivation	Bit	VAR_GLOBAL	M16
	SaveData1	Word [Signed]	VAR_GLOBAL	K4M100
	SaveData2	Word [Signed]	VAR_GLOBAL	K4M120
	SaveData3	Word [Signed]	VAR_GLOBAL	K2M128
	SaveData4	Word [Signed]	VAR_GLOBAL	K2M140
	SaveData5	Word [Signed]	VAR_GLOBAL	K2M148
	SaveData6	Word [Signed]	VAR_GLOBAL	K4M140
	SaveData7	Word [Signed]	VAR_GLOBAL	K2M100
	uResultsData	Word [Signed]	VAR_GLOBAL	D0

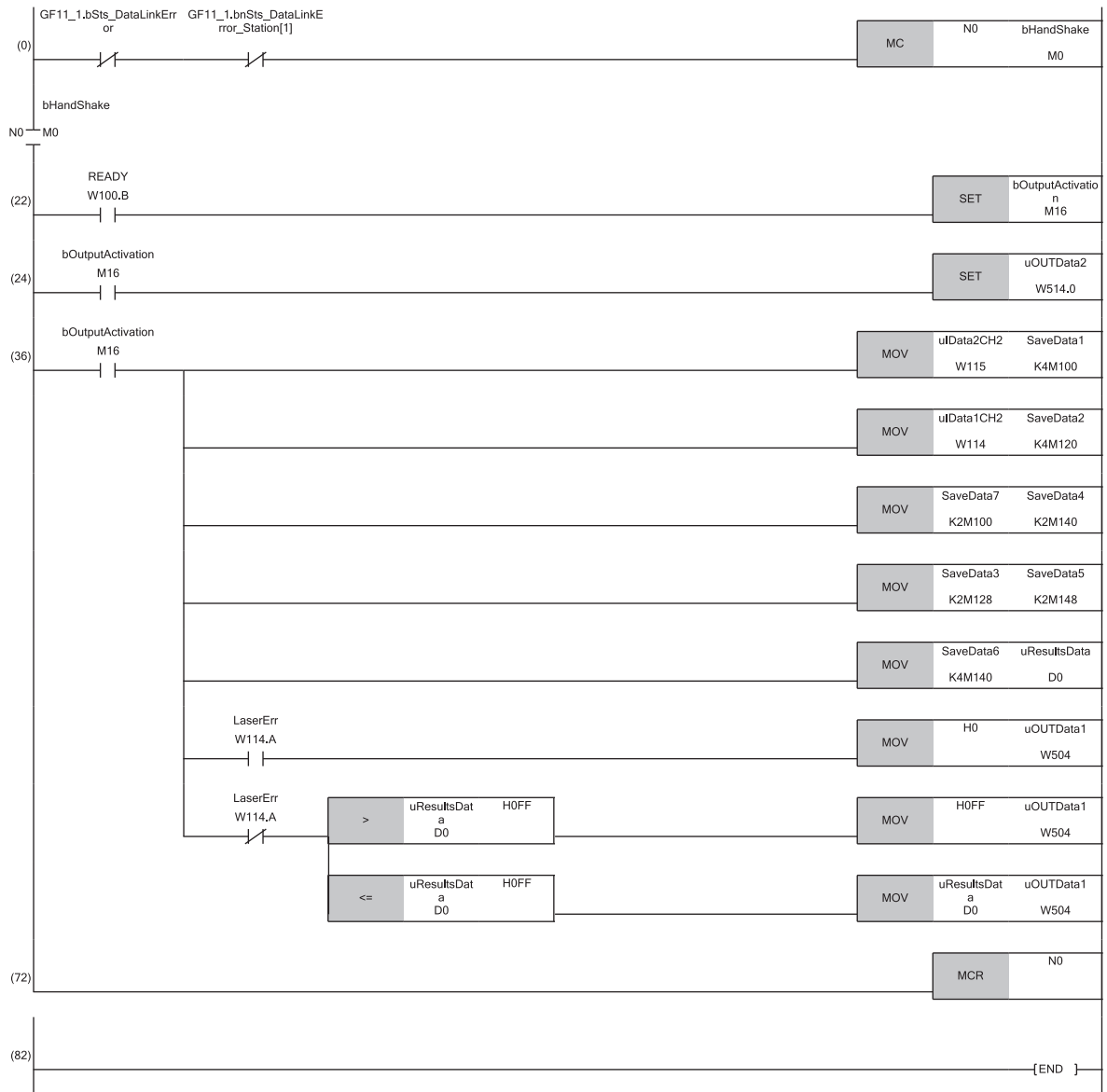

# 10 MAINTENANCE AND INSPECTION

---

The IO-Link module has no special item to be inspected. However, to maintain the best condition of the system, perform the inspection in accordance with the items described in the user's manual of the CPU module used.

# MEMO

---

# 11 TROUBLESHOOTING

This chapter describes error contents that may occur while the IO-Link module is used and how to troubleshoot.

## 11.1 Checking the LEDs

This section describes how to troubleshoot the system by the LEDs.

### When the US LED is on in red or off

Check item	Action
Is the sensor or actuator power supply voltage normal?	Check the external power supply voltage and installation environment.

### When the UA LED is on in red or flashes in red

Check item	Action
Is the sensor or actuator power supply voltage normal?	Check the external power supply voltage and installation environment.

### When the ERR. LED turns on

Check item	Action
Has any error occurred?	Identify the error factor of the IO-Link module with the engineering tool to take the corrective action. (☞ Page 124 Checking for the Error Codes and the Warning Codes)

### When the LINK LED is off

Check item	Action
Are Ethernet cables normal?	<ul style="list-style-type: none"> <li>• Check that 1000BASE-T-compliant Ethernet cables are used.</li> <li>• Check that the station-to-station distance is 100m or less.</li> <li>• Check that the Ethernet cables are not disconnected.</li> </ul>
Do the switching hub and other stations in the system normally operate?	<ul style="list-style-type: none"> <li>• Check that a 1000BASE-T-compliant switching hub is used. (📖 User's manual for the master/local module used)</li> <li>• Check that the power supplies of the switching hub and other stations are turned on.</li> </ul>

### When the L ER LED is on in red

Check item	Action
Does the own station in network operate normally?	Connect the engineering tool to the master station, and then check that a data link is established in the own station by using CC IE Field diagnostics. (📖 User's manual for the master/local module used)
Are Ethernet cables normal?	<ul style="list-style-type: none"> <li>• Check that 1000BASE-T-compliant Ethernet cables are used.</li> <li>• Check that the station-to-station distance is 100m or less.</li> <li>• Check that the Ethernet cables are not disconnected.</li> </ul>
Do the switching hub and other stations in the system normally operate?	<ul style="list-style-type: none"> <li>• Check that a 1000BASE-T-compliant switching hub is used. (📖 User's manual for the master/local module used)</li> <li>• Check that the power supplies of the switching hub and other stations are turned on.</li> </ul>
Is the mode setting of the module on the master station set to other than Online?	Change the mode setting of the module to Online. (📖 User's manual for the master/local module used)
Is there any noise affecting the system?	<ul style="list-style-type: none"> <li>• Check the status of wiring.</li> <li>• When wiring, avoid installing the IO-Link cable or Ethernet cable together with the main circuit lines or power cables, and avoid placing those cables in close proximity to each other.</li> <li>• Connect surge absorbers to noise-generating devices such as relays and conductors using the same power supply or take other noise reduction measures.</li> </ul>
Is the unit test normal? (☞ Page 120 Unit Test)	If an error occurs in the unit test, the module may be in failure. Please consult your local Mitsubishi representative.

## When the L ER LED is off

Check item	Action
Are Ethernet cables normal?	<ul style="list-style-type: none"> <li>• Check that 1000BASE-T-compliant Ethernet cables are used.</li> <li>• Check that the station-to-station distance is 100m or less.</li> <li>• Check that the Ethernet cables are not disconnected.</li> </ul>
Do the switching hub and other stations in the system normally operate?	<ul style="list-style-type: none"> <li>• Check that a 1000BASE-T-compliant switching hub is used. (📖 User's manual for the master/local module used)</li> <li>• Check that the power supplies of the switching hub and other stations are turned on.</li> </ul>
Is the mode setting of the module on the master station set to other than Online?	Change the mode setting of the module to Online. (📖 User's manual for the master/local module used)

## When the L ER LED flashes in green

Check item	Action
When the master station network topology setting is the ring topology, do the setting and network configuration match?	Configure the network in ring topology.

## When the CQ LED or Q LED is on in red

Check item	Action
Is overcurrent or overload occurring?	<ul style="list-style-type: none"> <li>• Ensure that the output is 2A or less.</li> <li>• Check the SIO mode output setting and ensure that the CQ or Q terminal and L+ terminal are not short-circuited in the OFF state.</li> <li>• Check the SIO mode output setting and ensure that the CQ or Q terminal and L-terminal are not short-circuited in the ON state.</li> </ul>

## When the CQ LED flashes in red

Check item	Action
Is an incompatible or unidentifiable IO-Link device connected when they are replaced?	<ul style="list-style-type: none"> <li>• When the IO-Link device validation setting is enabled, connect a compatible and identifiable IO-Link device.</li> <li>• When the data storage configuration is enabled, connect a compatible IO-Link device.</li> </ul>
Is the configured process data size larger than the process data size of the IO-Link devices used?	Check the process data size of each IO-Link device, and change the setting as needed. (📖 Page 86 Process data size)
Is the sensor or actuator power supply voltage normal?	Check the external power supply voltage and installation environment.

## When the CQ LED and Q LED flash in red

Check item	Action
Is overcurrent or overload occurring?	Check if there is any overload or short-circuit in the IO-Link connectors, between the L+, Q, and L- terminals.

## When the CQ LED flashes in green

Check item	Action
Are IO-Link cables normal?	<ul style="list-style-type: none"> <li>• When no IO-Link devices are connected: Refer to the following. 📖 Page 14 Part names of the IO-Link module</li> <li>• When the IO-Link device is connected: Check IO-Link cables for disconnection, reset the power of the IO-Link module, or set and execute "Write Value" of the channel setting in IO-Link parameters.</li> </ul>



## When the RUN LED is off

Check item	Action
Does the voltage of the module power supplied externally reach to the voltage of the specifications?	Check that the module power supply voltage is within the range of performance specifications. After the check, power off and on the module.
Does any hardware error occur?	If the RUN LED does not turn on even after the module power supply is turned off and on, the possible cause is a module failure. Please consult your local Mitsubishi representative.

## When the DISPLAY1 LED or DISPLAY2 LED flashes in red

Check item	Action
—	The possible cause is a module failure. Please consult your local Mitsubishi representative.

### Point

If link-up processing is repeated due to a condition of a device on the line, it may take a longer time for the LINK LED to turn on. This phenomenon may be eliminated by changing the module PORT into which the Ethernet cable is connected (example: P1 → P2).

# 11.2 Unit Test

Run a unit test to check if there is any error in the IO-Link module.

## Operating procedure

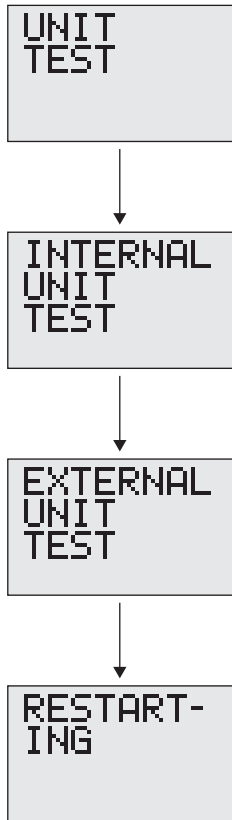

1. First, run an internal test. Power off the IO-Link module, and disconnect the cables from the communication connectors. (When the cables are not disconnected, the test result may be abnormal.)
2. Power on the IO-Link module.
3. Press the [SEL.] button on the module information window of the main menu, and select the unit test window.
4. Press and hold the [SET] button on the unit test window to start the internal test.
5. The internal test starts automatically. Check the test result in the following way.
  - If the test result is normal  
The DISPLAY1 LED and DISPLAY2 LED are on in green.
  - If the test result is abnormal  
The DISPLAY1 LED and DISPLAY2 LED are on in red.
6. Next, run an external test. Connect a cable between the IO-Link module communication connectors P1 and P2.
7. Press the [SEL.] button to start the external test. (The external test will not start if there is no cable connected between P1 and P2.)
8. The external test starts automatically. Check the test result in the following way.
  - If the test result is normal  
The DISPLAY1 LED and DISPLAY2 LED are on in green.
  - If the test result is abnormal  
The DISPLAY1 LED and DISPLAY2 LED are on in red.
9. Press the [SEL.] button to terminate the unit test. The IO-Link module will restart automatically when the unit test ends.

### Point

- If the unit test is not completed, check the operating procedure and run the test again.
- If the unit test result is abnormal, the IO-Link module hardware may be in failure. Please consult your local Mitsubishi representative.

# 11.3 Checking the Status of IO-Link Devices

Check the status of the IO-Link device connected to each channel.

There are two methods for checking as follows.

- Using an engineering tool
- Using the RIRD instruction

## Using an engineering tool

1. Display the "Command Execution of Slave Station" window from the "CC IE Field Configuration" window.

☞ From the list of stations, select an IO-Link module ⇒ [CC IE Field Configuration] ⇒ [Online] ⇒ [Command Execution of Slave Station].

2. Check the firmware version of the IO-Link module, and set "Method selection".

For the firmware version 2.0: "Device diagnostics for V2.0"

For the firmware version 2.0.2 or later: "Device diagnostics for V2.0.2 or later"

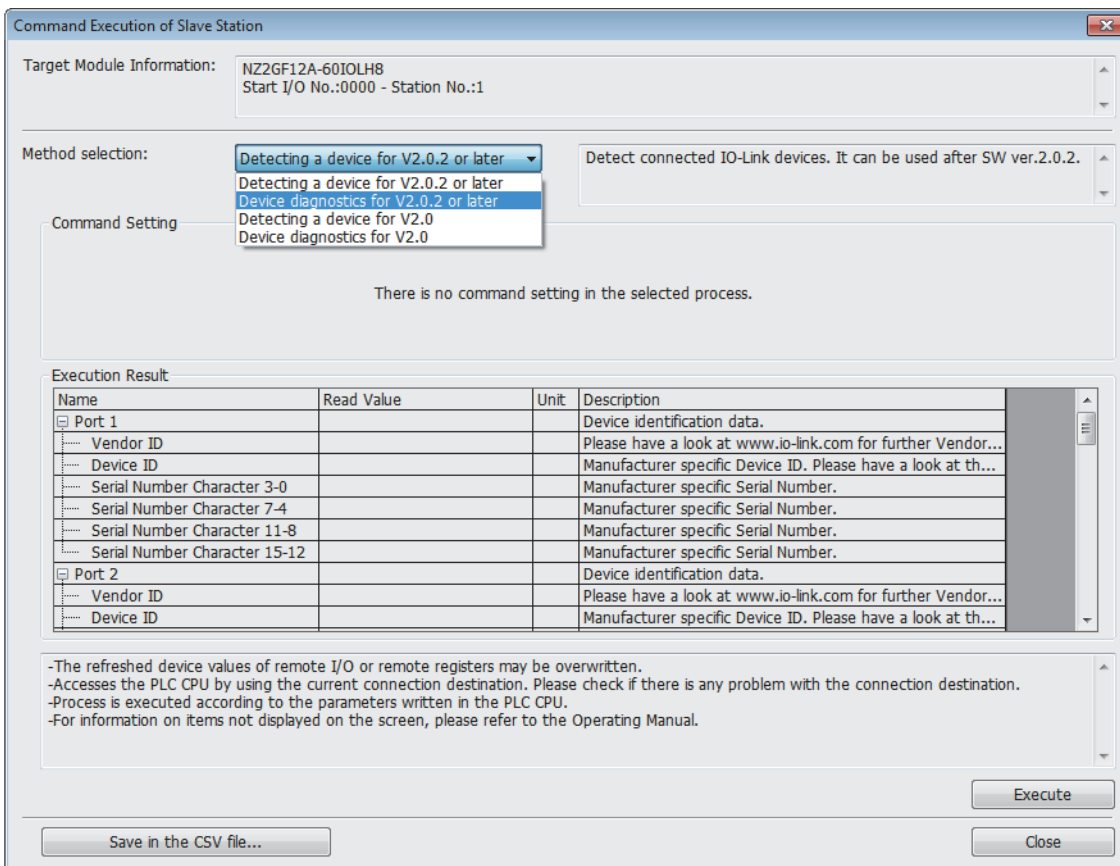

3. Click the "Execute" button.

## Using the RIRD instruction

Read event data of the IO-Link devices using the RIRD instruction.

For details, refer to the following.

☞ Page 92 Event data

# 11.4 Troubleshooting for Each Phenomenon

This section describes troubleshooting for each phenomenon.

Perform troubleshooting for each phenomenon when the IO-Link module does not operate properly with no error. If an error occurs in the IO-Link module, identify the cause of the error using the engineering tool.

Check the following items in the order from the top.

## When the ON/OFF status of an external input cannot be read

Check item	Action
Is the LED (CQ LED or Q LED) of the corresponding channels of the IO-Link module turned on when the external input device turns on?	If the LED does not turn on, there is a problem on the input wiring. Check the wiring confirming that the input wiring is not disconnected or short-circuited, or the voltage of the input signal is correct. For details on the rated input voltage, refer to the following. ☞ Page 21 Performance Specifications
Is the setting of the refresh device correct?	Check the refresh parameter and correct the setting of the refresh device so that it matches with the setting in the program. For the setting of the refresh parameters, refer to the following. 📖 User's manual for the master/local module used
Is Remote READY (RWr0.b11) on?	To enable reading the ON/OFF status of the external input when the module power supply is on, the initial processing must be executed by using Initial processing request flag (RWr0.b8) and Initial processing completion flag (RWw0.b8). Execute the initial processing to check that Remote READY (RWr0.b11) is on. For details, refer to the following. ☞ Page 143 Remote READY (RWr0.b11)  Connect the engineering tool to the master station, and then check that a data link is established in the own station by using CC IE Field diagnostics. (📖 User's manual for the master/local module used)
Is any bit of Channel n (CQ/Q) short-circuit detection flag (RX10 to RX1F) and Channel n (L+) short-circuit detection flag (RX20 to RX27) turned on?	If any bit of Channel n (CQ/Q) short-circuit detection flag (RX10 to RX1F) and Channel n (L+) short-circuit detection flag (RX20 to RX27) is turned on, this means that an error such as short-circuit is detected on the channel corresponding to the bit. Check the wiring confirming that the input wiring is not disconnected or short-circuited, or the voltage of the input signal is correct.

## When the ON/OFF status of an external output cannot be changed

Check item	Action
Is the LED (CQ LED or Q LED) of the corresponding channels of the IO-Link module turned on when Channel n (CQ/Q) external output signal 0 to F (RY0 to RYF) turns on?	If the LED turns on, there is a problem on the output wiring. Check the wiring confirming that the output wiring is not disconnected or short-circuited.
Is the setting of the refresh device correct?	Check the refresh parameter and correct the setting of the refresh device so that it matches with the setting in the program. For the setting of the refresh parameters, refer to the following. 📖 User's manual for the master/local module used
Is Remote READY (RWr0.b11) on?	To enable changing the ON/OFF status of the external output when the module power supply is on, the initial processing must be executed by using Initial processing request flag (RWr0.b8) and Initial processing completion flag (RWw0.b8). Execute the initial processing to check that Remote READY (RWr0.b11) is on. For details, refer to the following. ☞ Page 143 Remote READY (RWr0.b11)  Connect the engineering tool to the master station, and then check that a data link is established in the own station by using CC IE Field diagnostics. (📖 User's manual for the master/local module used)
Is any bit of Channel n (CQ/Q) short-circuit detection flag (RX10 to RX1F) and Channel n (L+) short-circuit detection flag (RX20 to RX27) turned on?	If any bit of Channel n (CQ/Q) short-circuit detection flag (RX10 to RX1F) and Channel n (L+) short-circuit detection flag (RX20 to RX27) is turned on, this means that an error such as short-circuit is detected on the channel corresponding to the bit. Check the wiring confirming that the input wiring is not disconnected or short-circuited, or the voltage of the input signal is correct.



### Point

If an external input cannot be read or an external output cannot be controlled even after the above actions are taken, the IO-Link module may be failed. Please consult your local Mitsubishi representative.

## When parameters cannot be read or written

Check item	Action
Is the version of the engineering tool supported?	Please consult your local Mitsubishi representative.
Do the setting of the network parameter and that of the CPU module match?	Perform sequencer verification on the network parameter to check those settings. When they are not matched, match the setting of the network parameter to that of the sequencer and write the module parameter of the slave station.

## When an IO-Link device cannot be communicated with

Check item	Action
Is the process data size is assigned properly to each channel?	For the process data size, specify the number of words not less than the process data size of the IO-Link device used. (If the IO-Link device controls 3-byte process data, set the process data size to two words (4 bytes) or more.) For details, refer to the specifications of the IO-Link device used.
Is device validation configured properly?	If the device is determined to be not compatible or identifiable as a result of device validation, check whether an intended IO-Link device is connected or review the IO-Link device connection. Check also if the IO-Link device validation setting on the IO-Link module is correct.
Is the setting of the refresh device correct?	Check the refresh parameter and correct the setting of the refresh device so that it matches with the setting in the program. For the setting of the refresh parameters, refer to the following.  User's manual for the master/local module used
Is Remote READY (RWr0.b11) on?	To enable reading/writing process data when the module power supply is on, the initial processing must be executed by using Initial processing request flag (RWr0.b8) and Initial processing completion flag (Rw0.b8). Execute the initial processing to check that Remote READY (RWr0.b11) is on. For details, refer to the following.  Page 143 Remote READY (RWr0.b11)  Connect the engineering tool to the master station, and then check that a data link is established in the own station by using CC IE Field diagnostics. (  User's manual for the master/local module used)
Is any bit of Channel n (CQ/Q) short-circuit detection flag (RX10 to RX1F) and Channel n (L+) short-circuit detection flag (RX20 to RX27) turned on?	If any bit of Channel n (CQ/Q) short-circuit detection flag (RX10 to RX1F) and Channel n (L+) short-circuit detection flag (RX20 to RX27) is turned on, this means that an error such as short-circuit is detected on the channel corresponding to the bit. Check the wiring confirming that the wiring is not disconnected or short-circuited, or the voltage of the signal is correct.

## When a signal incorrectly inputs data

Check item	Action
Is noise taken as input data?	<ul style="list-style-type: none"> <li>To prevent excessive noise, avoid installing power cables together with I/O cables.</li> <li>Connect surge absorbers to noise-generating devices such as relays and conductors using the same power supply or take other noise reduction measures.</li> </ul>

# 11.5 Checking for the Error Codes and the Warning Codes

Error codes can be checked by any of the following methods:

- ☞ Page 124 Checking by Error code (RWr1)
- ☞ Page 125 Checking on the display part

Warning codes can be checked by any of the following methods:

- ☞ Page 124 Checking by Warning code (RWr2)

For contents of error codes and warning codes, refer to the following.

- ☞ Page 126 List of Error Codes and the Warning Codes

## Checking by Error code (RWr1)

Check the latest error code with the remote register of the master/local module.

☞ [Online] ⇒ [Monitor] ⇒ [Device/Buffer Memory Batch Monitor]

**Ex.**

When the refresh target device for Error code (RWr1) is W101

The screenshot shows the 'Device Name' dropdown set to 'W101'. Below it is a table with columns for Device Name, hexadecimal digits (F, E, D, C, B, A, 9, 8, 7, 6, 5, 4, 3, 2, 1, 0), Current Value, and String. The row for W101 shows a '1' in the '8' column and a '1' in the '0' column, with a Current Value of 257 and a String of '-'. Other rows (W102-W105) show all zeros and a Current Value of 0.

Device Name	F	E	D	C	B	A	9	8	7	6	5	4	3	2	1	0	Current Value	String
W101	0	0	0	0	0	0	0	1	0	0	0	0	0	0	0	1	257	-
W102	0	0	0	0	0	0	0	0	0	0	0	0	0	0	0	0	0	-
W103	0	0	0	0	0	0	0	0	0	0	0	0	0	0	0	0	0	-
W104	0	0	0	0	0	0	0	0	0	0	0	0	0	0	0	0	0	-
W105	0	0	0	0	0	0	0	0	0	0	0	0	0	0	0	0	0	-

## Checking by Warning code (RWr2)

Check the latest warning code with the remote register of the master/local module.

☞ [Online] ⇒ [Monitor] ⇒ [Device/Buffer Memory Batch Monitor]

**Ex.**

When the refresh target device for Warning code (RWr2) is W102

The screenshot shows the 'Device Name' dropdown set to 'W102'. Below it is a table with columns for Device Name, hexadecimal digits (F, E, D, C, B, A, 9, 8, 7, 6, 5, 4, 3, 2, 1, 0), Current Value, and String. The row for W102 shows a '1' in the '8' column and '1' in the '1' and '0' columns, with a Current Value of 259 and a String of '-'. Other rows (W103-W106) show all zeros and a Current Value of 0.

Device Name	F	E	D	C	B	A	9	8	7	6	5	4	3	2	1	0	Current Value	String
W102	0	0	0	0	0	0	0	1	0	0	0	0	0	0	1	1	259	-
W103	0	0	0	0	0	0	0	0	0	0	0	0	0	0	0	0	0	-
W104	0	0	0	0	0	0	0	0	0	0	0	0	0	0	0	0	0	-
W105	0	0	0	0	0	0	0	0	0	0	0	0	0	0	0	0	0	-
W106	0	0	0	0	0	0	0	0	0	0	0	0	0	0	0	0	0	-

## Checking on the display part

A maximum of 16 error codes of major errors that have occurred can be checked on the display part. (Moderate and minor errors are not displayed.)

The 17th and subsequent major errors are not displayed.

### Operating procedure

```
MAJOR
ERRORS
0
```

```
PAGE  0:
00000000
00000000
```

```
PAGE  1:
00000000
00000000
```

```
PAGE 15:
00000000
00000000
```

1. Press the [SEL.] button on the module information window of the main menu, and select the major error window. Number of the occurred errors can be checked on the major error window.
2. Press and hold the [SET] button on the major error window to check the error code. The error codes are displayed one by one by pressing the [SEL.] button. Pressing the [SEL.] button on the "PAGE 15" window, the display returns to the "PAGE 0" window. The windows are displayed as follows.
  - 1st line: Page number ("PAGE 0" to "PAGE 15")
  - 2nd line: Error code (☞ Page 126 List of Error Codes and the Warning Codes)
  - 3rd line: Information to be used in the system
3. Press [SET] button to go back to the major error window.

11

### Point

The IO-Link module does not operate properly if a major error occurs, therefore the error content may not be checked with the engineering tool.

In this case, check the error content on the display part.

If the error content cannot be checked on the display part either, the IO-Link module may be in failure. Please consult your local Mitsubishi representative.

# 11.6 List of Error Codes and the Warning Codes

This section describes error codes and warning codes.

**Point** 

If an error not described in this manual occurs on an IO-Link device, refer to the manual of the IO-Link device used.

## List of Error Codes and the Warning Codes

The error codes and warning codes are classified into the following three types.

Classification		Description
Error code	Major error	An error that cannot be recovered
	Moderate error	An error where the module cannot continue to operate
Warning code	Minor error	An error where the module can continue to operate

Error code (hexadecimal)	Classification	Error definition and cause	Action
0001H	Major error	The WDT (watchdog timer) has timed out.	<ul style="list-style-type: none"> <li>Take measures against noise with a shielded cable for connection. Then turn off and on the module.</li> <li>If this error persists, the module may be in failure. Please consult your local Mitsubishi representative.</li> </ul>
0002H	Major error	The bus inside the module is faulty.	
0003H	Major error	The data in the nonvolatile memory are faulty.	
0004H	Major error	An error has been detected in the RAM diagnostics upon start up.	
0005H	Major error	Communication inside the module is faulty.	
0101H	Moderate error	The module/sensor power supply voltage or the output power supply voltage is faulty.	Check US voltage drop flag (18V or lower) (RX28), UA voltage drop flag (18V or lower) (RX29), and UA voltage drop flag (11V or lower) (RX2A), and confirm the wiring and status of the relevant power supplies.
0102H	Moderate error	Short-circuit has been detected on a port or pin.	Check Channel n (CQ/Q) short-circuit detection flag (RX10 to RX1F) and Channel n (L+) short-circuit detection flag (RX20 to RX27), and confirm the status of the relevant channel or pin.
0103H	Minor error	The station number/network setting have been changed with the module power on.	Set the switch again to the station number or network number that has been set before.
0104H	Minor error	The setting was changed while the system was in operation.	This error is automatically recovered. However, if this error persists, the module may be in failure. Please consult your local Mitsubishi representative.
D529H	Major error	A hardware error has occurred in the communication LSI.	<ul style="list-style-type: none"> <li>A malfunction may have occurred due to noise or others. Check the cable distance or grounding condition of each device. Then take measures against noise.</li> <li>If this error persists, the module may be in failure. Please consult your local Mitsubishi representative.</li> </ul>
D52AH	Major error		
D52BH	Major error		
D52CH	Major error		
D0A0H	Moderate error	A response wait timeout has occurred in transient transmission.	<ul style="list-style-type: none"> <li>If an error has been detected on the own station, target station, or relay station, check and address the error.</li> <li>Decrease the usage frequency of transient transmission, and retry the operation.</li> <li>If the master station (submaster station) is in the mode "Online (high-speed mode)", switch the mode to "Online (normal mode)", and retry the operation.</li> <li>Check cables of the request source and switching hub connection for any error.</li> </ul>
D0A1H	Moderate error	A transmission completion wait timeout has occurred in transient transmission.	
D0A2H	Moderate error	A transmission wait timeout has occurred in transient transmission.	



Error code (hexadecimal)	Classification	Error definition and cause	Action
D0A3H	Moderate error	The send processing of transient transmission has not been done successfully.	<ul style="list-style-type: none"> <li>• If an error has been detected on the own station, target station, or relay station, check and address the error.</li> <li>• Correct the target station number of the transient data, and retry the operation.</li> <li>• If a module with another network number is accessed, confirm that "Routing Setting" of "CPU Parameter" is configured correctly.</li> </ul>
E211H	Moderate error	The ISDU index is not available.	Refer to the manual of the connected IO-Link device and correct the ISDU index.
E212H	Moderate error	The ISDU subindex is not available.	Refer to the manual of the connected IO-Link device and correct the ISDU subindex.
E220H	Moderate error	The service is temporarily unavailable.	Wait some time and try again.
E221H	Moderate error		
E222H	Moderate error		
E223H	Moderate error	<ul style="list-style-type: none"> <li>• Access to the ISDU write command is denied.</li> <li>• Access to the ISDU read command is denied.</li> </ul>	<ul style="list-style-type: none"> <li>• The index is read-only.</li> <li>• The index is write-only.</li> </ul>
E230H	Moderate error	The parameter value is out of range.	Refer to the manual of the connected IO-Link device and correct the parameter value.
E231H	Moderate error	The parameter value exceeds the defined value.	
E232H	Moderate error	The parameter value is below the defined value.	
E233H	Moderate error	The length of the parameter is too long.	Refer to the manual of the connected IO-Link device and correct the parameter length.
E234H	Moderate error	The length of the parameter is too short.	
E235H	Moderate error	The function is not available.	Refer to the manual of the connected IO-Link device.
E236H	Moderate error	The function is temporarily unavailable.	Wait some time and try again.
E240H	Moderate error	An invalid parameter is set.	Refer to the manual of the connected IO-Link device and set a valid parameter.
E241H	Moderate error	An incompatible parameter is set.	Refer to the manual of the connected IO-Link device and set a compatible parameter.

## Error Code List (Communication Error)

Error code (hexadecimal)	Classification	Error definition and cause	Action
E106H	Communication error	Incorrect data was requested in transient transmission.	Check the data of the RIWT instruction.
E107H	Communication error	The IO-Link request failed.	
E108H	Communication error	The IO-Link setting data is incorrect.	
E109H	Communication error	The attribute code of transient transmission is incorrect.	Correct the attribute code using the RIWT instruction, and retry the operation.
E110H	Communication error		
E112H	Communication error		
E113H	Communication error	The number of data to read/write in transient transmission is incorrect.	Correct the read address and write address using the RIWT instruction, and retry the operation.
E114H	Communication error	The received transient data is incorrect.	Correct the number of data (frame length) using the RIWT instruction, and retry the operation.
E115H	Communication error	The access code of transient transmission is incorrect.	Correct the access code using the RIWT instruction, and retry the operation.
E116H	Communication error	The attribute code of transient transmission is incorrect.	Correct the attribute code using the RIRD instruction, and retry the operation.
E118H	Communication error		
E119H	Communication error	The number of data to read/write in transient transmission is incorrect.	Correct the read address and write address using the RIRD instruction, and retry the operation.
E120H	Communication error	The received transient data is incorrect.	Correct the number of data (frame length) using the RIRD instruction, and retry the operation.
E121H	Communication error	The access code of transient transmission is incorrect.	Correct the access code using the RIRD instruction, and retry the operation.
E123H	Communication error	The requested data is incorrect.	Check the parameter of the RIRD instruction.

# APPENDICES

## Appendix 1 Remote I/O Signals

This section lists I/O signals for a master/local module.

Remote input (RX) indicates the input signal from the IO-Link module to the master/local module.

Remote output (RY) indicates the output signal from the master/local module to the IO-Link module.

The remote I/O signals of the IO-Link module are assigned as shown below.

Module	Remote input (RX)	Remote output (RY)
IO-Link module	RX0 to RX4F	RY0 to RY4F

### Point

Do not use any "Use prohibited" remote I/O signals. Doing so may cause an accident due to incorrect output or malfunction.

### List of remote I/O signals

Remote input		Remote output	
Signal direction: IO-Link module → Master/local module		Signal direction: Master/local module → IO-Link module	
Device number	Signal name	Device number	Signal name
RX0	Channel 1 (CQ) external input signal 0	RY0	Channel 1 (CQ) external output signal 0
RX1	Channel 1 (Q) external input signal 1	RY1	Channel 1 (Q) external output signal 1
RX2	Channel 2 (CQ) external input signal 2	RY2	Channel 2 (CQ) external output signal 2
RX3	Channel 2 (Q) external input signal 3	RY3	Channel 2 (Q) external output signal 3
RX4	Channel 3 (CQ) external input signal 4	RY4	Channel 3 (CQ) external output signal 4
RX5	Channel 3 (Q) external input signal 5	RY5	Channel 3 (Q) external output signal 5
RX6	Channel 4 (CQ) external input signal 6	RY6	Channel 4 (CQ) external output signal 6
RX7	Channel 4 (Q) external input signal 7	RY7	Channel 4 (Q) external output signal 7
RX8	Channel 5 (CQ) external input signal 8	RY8	Channel 5 (CQ) external output signal 8
RX9	Channel 5 (Q) external input signal 9	RY9	Channel 5 (Q) external output signal 9
RXA	Channel 6 (CQ) external input signal A	RYA	Channel 6 (CQ) external output signal A
RXB	Channel 6 (Q) external input signal B	RYB	Channel 6 (Q) external output signal B
RXC	Channel 7 (CQ) external input signal C	RYC	Channel 7 (CQ) external output signal C
RXD	Channel 7 (Q) external input signal D	RYD	Channel 7 (Q) external output signal D
RXE	Channel 8 (CQ) external input signal E	RYE	Channel 8 (CQ) external output signal E
RXF	Channel 8 (Q) external input signal F	RYF	Channel 8 (Q) external output signal F
RX10	Channel 1 (CQ) short-circuit detection flag	RY10	Channel 1 (CQ) I/O switching command
RX11	Channel 1 (Q) short-circuit detection flag	RY11	Channel 1 (Q) I/O switching command
RX12	Channel 2 (CQ) short-circuit detection flag	RY12	Channel 2 (CQ) I/O switching command
RX13	Channel 2 (Q) short-circuit detection flag	RY13	Channel 2 (Q) I/O switching command
RX14	Channel 3 (CQ) short-circuit detection flag	RY14	Channel 3 (CQ) I/O switching command
RX15	Channel 3 (Q) short-circuit detection flag	RY15	Channel 3 (Q) I/O switching command
RX16	Channel 4 (CQ) short-circuit detection flag	RY16	Channel 4 (CQ) I/O switching command
RX17	Channel 4 (Q) short-circuit detection flag	RY17	Channel 4 (Q) I/O switching command
RX18	Channel 5 (CQ) short-circuit detection flag	RY18	Channel 5 (CQ) I/O switching command
RX19	Channel 5 (Q) short-circuit detection flag	RY19	Channel 5 (Q) I/O switching command
RX1A	Channel 6 (CQ) short-circuit detection flag	RY1A	Channel 6 (CQ) I/O switching command
RX1B	Channel 6 (Q) short-circuit detection flag	RY1B	Channel 6 (Q) I/O switching command
RX1C	Channel 7 (CQ) short-circuit detection flag	RY1C	Channel 7 (CQ) I/O switching command
RX1D	Channel 7 (Q) short-circuit detection flag	RY1D	Channel 7 (Q) I/O switching command
RX1E	Channel 8 (CQ) short-circuit detection flag	RY1E	Channel 8 (CQ) I/O switching command

Remote input		Remote output	
Signal direction: IO-Link module → Master/local module		Signal direction: Master/local module → IO-Link module	
Device number	Signal name	Device number	Signal name
RX1F	Channel 8 (Q) short-circuit detection flag	RY1F	Channel 8 (Q) I/O switching command
RX20	Channel 1 (L+) short-circuit detection flag	RY20	Display LED1, LED2
RX21	Channel 2 (L+) short-circuit detection flag	RY21	Display LED1, LED2
RX22	Channel 3 (L+) short-circuit detection flag	RY22	Display lock
RX23	Channel 4 (L+) short-circuit detection flag	RY23	Use prohibited
RX24	Channel 5 (L+) short-circuit detection flag	RY24	
RX25	Channel 6 (L+) short-circuit detection flag	RY25	
RX26	Channel 7 (L+) short-circuit detection flag	RY26	
RX27	Channel 8 (L+) short-circuit detection flag	RY27	
RX28	US voltage drop flag (18V or lower)	RY28	
RX29	UA voltage drop flag (18V or lower)	RY29	
RX2A	UA voltage drop flag (11V or lower)	RY2A	
RX2B	Use prohibited	RY2B	
RX2C		RY2C	
RX2D		RY2D	
RX2E		RY2E	
RX2F		RY2F	
RX30		Channel 1 communication start flag	
RX31	Channel 2 communication start flag	RY31	Channel 2 mode switching command
RX32	Channel 3 communication start flag	RY32	Channel 3 mode switching command
RX33	Channel 4 communication start flag	RY33	Channel 4 mode switching command
RX34	Channel 5 communication start flag	RY34	Channel 5 mode switching command
RX35	Channel 6 communication start flag	RY35	Channel 6 mode switching command
RX36	Channel 7 communication start flag	RY36	Channel 7 mode switching command
RX37	Channel 8 communication start flag	RY37	Channel 8 mode switching command
RX38	Channel 1 event flag	RY38	Channel 1 event deletion
RX39	Channel 2 event flag	RY39	Channel 2 event deletion
RX3A	Channel 3 event flag	RY3A	Channel 3 event deletion
RX3B	Channel 4 event flag	RY3B	Channel 4 event deletion
RX3C	Channel 5 event flag	RY3C	Channel 5 event deletion
RX3D	Channel 6 event flag	RY3D	Channel 6 event deletion
RX3E	Channel 7 event flag	RY3E	Channel 7 event deletion
RX3F	Channel 8 event flag	RY3F	Channel 8 event deletion
RX40	Channel 1 data valid flag	RY40	Use prohibited
RX41	Channel 2 data valid flag	RY41	
RX42	Channel 3 data valid flag	RY42	
RX43	Channel 4 data valid flag	RY43	
RX44	Channel 5 data valid flag	RY44	
RX45	Channel 6 data valid flag	RY45	
RX46	Channel 7 data valid flag	RY46	
RX47	Channel 8 data valid flag	RY47	
RX48	Use prohibited	RY48	
RX49		RY49	
RX4A		RY4A	
RX4B		RY4B	
RX4C		RY4C	
RX4D		RY4D	
RX4E		RY4E	
RX4F		RY4F	

## Details of remote input signals

### Channel n (CQ/Q) external input signal 0 to F (RX0 to RXF)

The input ON/OFF status is applied from the external device connected to each channel. (n = 1 to 8)

Devices available for this signal differ depending on the mode.

○: Available, ×: Not available

Device number	Signal name	Description	Mode		
			IO-Link mode	SIO mode (digital input)	SIO mode (digital output)
RX0	Channel 1 (CQ) external input signal 0	The input ON/OFF status is applied from the external device connected to channel 1 to the CQ terminal.	×	○	×
RX1	Channel 1 (Q) external input signal 1	The input ON/OFF status is applied from the external device connected to channel 1 to the Q terminal.	○	○	×
RX2	Channel 2 (CQ) external input signal 2	The input ON/OFF status is applied from the external device connected to channel 2 to the CQ terminal.	×	○	×
RX3	Channel 2 (Q) external input signal 3	The input ON/OFF status is applied from the external device connected to channel 2 to the Q terminal.	○	○	×
RX4	Channel 3 (CQ) external input signal 4	The input ON/OFF status is applied from the external device connected to channel 3 to the CQ terminal.	×	○	×
RX5	Channel 3 (Q) external input signal 5	The input ON/OFF status is applied from the external device connected to channel 3 to the Q terminal.	○	○	×
RX6	Channel 4 (CQ) external input signal 6	The input ON/OFF status is applied from the external device connected to channel 4 to the CQ terminal.	×	○	×
RX7	Channel 4 (Q) external input signal 7	The input ON/OFF status is applied from the external device connected to channel 4 to the Q terminal.	○	○	×
RX8	Channel 5 (CQ) external input signal 8	The input ON/OFF status is applied from the external device connected to channel 5 to the CQ terminal.	×	○	×
RX9	Channel 5 (Q) external input signal 9	The input ON/OFF status is applied from the external device connected to channel 5 to the Q terminal.	○	○	×
RXA	Channel 6 (CQ) external input signal A	The input ON/OFF status is applied from the external device connected to channel 6 to the CQ terminal.	×	○	×
RXB	Channel 6 (Q) external input signal B	The input ON/OFF status is applied from the external device connected to channel 6 to the Q terminal.	○	○	×
RXC	Channel 7 (CQ) external input signal C	The input ON/OFF status is applied from the external device connected to channel 7 to the CQ terminal.	×	○	×
RXD	Channel 7 (Q) external input signal D	The input ON/OFF status is applied from the external device connected to channel 7 to the Q terminal.	○	○	×
RXE	Channel 8 (CQ) external input signal E	The input ON/OFF status is applied from the external device connected to channel 8 to the CQ terminal.	×	○	×
RXF	Channel 8 (Q) external input signal F	The input ON/OFF status is applied from the external device connected to channel 8 to the Q terminal.	○	○	×

A

## Channel n (CQ/Q) short-circuit detection flag (RX10 to RX1F)

This flag is used to detect a short-circuit on the CQ or Q terminal connected to each channel. (n = 1 to 8)

Devices available for this signal differ depending on the mode.

○: Available, ×: Not available

Device number	Signal name	Description	Mode		
			IO-Link mode	SIO mode (digital input)	SIO mode (digital output)
RX10	Channel 1 (CQ) short-circuit detection flag	Turned on when a short-circuit is detected on the CQ terminal on channel 1.	×	×	○
RX11	Channel 1 (Q) short-circuit detection flag	Turned on when a short-circuit is detected on the Q terminal on channel 1.	×	×	○
RX12	Channel 2 (CQ) short-circuit detection flag	Turned on when a short-circuit is detected on the CQ terminal on channel 2.	×	×	○
RX13	Channel 2 (Q) short-circuit detection flag	Turned on when a short-circuit is detected on the Q terminal on channel 2.	×	×	○
RX14	Channel 3 (CQ) short-circuit detection flag	Turned on when a short-circuit is detected on the CQ terminal on channel 3.	×	×	○
RX15	Channel 3 (Q) short-circuit detection flag	Turned on when a short-circuit is detected on the Q terminal on channel 3.	×	×	○
RX16	Channel 4 (CQ) short-circuit detection flag	Turned on when a short-circuit is detected on the CQ terminal on channel 4.	×	×	○
RX17	Channel 4 (Q) short-circuit detection flag	Turned on when a short-circuit is detected on the Q terminal on channel 4.	×	×	○
RX18	Channel 5 (CQ) short-circuit detection flag	Turned on when a short-circuit is detected on the CQ terminal on channel 5.	×	×	○
RX19	Channel 5 (Q) short-circuit detection flag	Turned on when a short-circuit is detected on the Q terminal on channel 5.	×	×	○
RX1A	Channel 6 (CQ) short-circuit detection flag	Turned on when a short-circuit is detected on the CQ terminal on channel 6.	×	×	○
RX1B	Channel 6 (Q) short-circuit detection flag	Turned on when a short-circuit is detected on the Q terminal on channel 6.	×	×	○
RX1C	Channel 7 (CQ) short-circuit detection flag	Turned on when a short-circuit is detected on the CQ terminal on channel 7.	×	×	○
RX1D	Channel 7 (Q) short-circuit detection flag	Turned on when a short-circuit is detected on the Q terminal on channel 7.	×	×	○
RX1E	Channel 8 (CQ) short-circuit detection flag	Turned on when a short-circuit is detected on the CQ terminal on channel 8.	×	×	○
RX1F	Channel 8 (Q) short-circuit detection flag	Turned on when a short-circuit is detected on the Q terminal on channel 8.	×	×	○

## Channel n (L+) short-circuit detection flag (RX20 to RX27)

This flag is used to detect a short-circuit on the L+ terminal connected to each channel. (n = 1 to 8)

Devices available for this signal differ depending on the mode.

○: Available, ×: Not available

Device number	Signal name	Description	Mode		
			IO-Link mode	SIO mode (digital input)	SIO mode (digital output)
RX20	Channel 1 (L+) short-circuit detection flag	Turned on when a short-circuit is detected on the L+ terminal on channel 1.	○	○	○
RX21	Channel 2 (L+) short-circuit detection flag	Turned on when a short-circuit is detected on the L+ terminal on channel 2.	○	○	○
RX22	Channel 3 (L+) short-circuit detection flag	Turned on when a short-circuit is detected on the L+ terminal on channel 3.	○	○	○
RX23	Channel 4 (L+) short-circuit detection flag	Turned on when a short-circuit is detected on the L+ terminal on channel 4.	○	○	○
RX24	Channel 5 (L+) short-circuit detection flag	Turned on when a short-circuit is detected on the L+ terminal on channel 5.	○	○	○
RX25	Channel 6 (L+) short-circuit detection flag	Turned on when a short-circuit is detected on the L+ terminal on channel 6.	○	○	○
RX26	Channel 7 (L+) short-circuit detection flag	Turned on when a short-circuit is detected on the L+ terminal on channel 7.	○	○	○
RX27	Channel 8 (L+) short-circuit detection flag	Turned on when a short-circuit is detected on the L+ terminal on channel 8.	○	○	○

### **US voltage drop flag (18V or lower) (RX28)**

Turned on if the module/sensor power supply (US) voltage is 18V or less.

### **UA voltage drop flag (18V or lower) (RX29)**

Turned on if the actuator power supply (UA) voltage is 18V or less.

### **UA voltage drop flag (11V or lower) (RX2A)**

Turned on if the actuator power supply (UA) voltage is 11V or less. (The UA voltage drop flag (18V or lower) (RX29) also turns on.)

### **Channel n communication start flag (RX30 to RX37)**

This signal turns on when the communication with the IO-Link device connected to each channel starts, and turns off when the communication terminates. (n = 1 to 8)

This signal is available only in the IO-Link mode.

### **Channel n event flag (RX38 to RX3F)**

This signal turns on if an event occurs on the IO-Link device connected to each channel. (n = 1 to 8)

This signal turns off when all the events that have occurred are read via transient transmission.

This signal is available only in the IO-Link mode.

### **Channel n data valid flag (RX40 to RX47)**

This signal turns on if the process data of the IO-Link device connected to each channel is valid. (n = 1 to 8)

This signal does not turn on if the IO-Link device is not communicated with.

This signal is available only in the IO-Link mode.



## Details of remote output signals

### Channel n (CQ/Q) external output signal 0 to F (RY0 to RYF)

The output ON/OFF status is applied to the external device connected to each channel. (n = 1 to 8)

Devices available for this signal differ depending on the mode.

○: Available, ×: Not available

Device number	Signal name	Description	Mode		
			IO-Link mode	SIO mode (digital input)	SIO mode (digital output)
RY0	Channel 1 (CQ) external output signal 0	The output ON/OFF status is applied from the CQ terminal to the external device connected to channel 1.	×	×	○
RY1	Channel 1 (Q) external output signal 1	The output ON/OFF status is applied from the Q terminal to the external device connected to channel 1.	○	×	○
RY2	Channel 2 (CQ) external output signal 2	The output ON/OFF status is applied from the CQ terminal to the external device connected to channel 2.	×	×	○
RY3	Channel 2 (Q) external output signal 3	The output ON/OFF status is applied from the Q terminal to the external device connected to channel 2.	○	×	○
RY4	Channel 3 (CQ) external output signal 4	The output ON/OFF status is applied from the CQ terminal to the external device connected to channel 3.	×	×	○
RY5	Channel 3 (Q) external output signal 5	The output ON/OFF status is applied from the Q terminal to the external device connected to channel 3.	○	×	○
RY6	Channel 4 (CQ) external output signal 6	The output ON/OFF status is applied from the CQ terminal to the external device connected to channel 4.	×	×	○
RY7	Channel 4 (Q) external output signal 7	The output ON/OFF status is applied from the Q terminal to the external device connected to channel 4.	○	×	○
RY8	Channel 5 (CQ) external output signal 8	The output ON/OFF status is applied from the CQ terminal to the external device connected to channel 5.	×	×	○
RY9	Channel 5 (Q) external output signal 9	The output ON/OFF status is applied from the Q terminal to the external device connected to channel 5.	○	×	○
RYA	Channel 6 (CQ) external output signal A	The output ON/OFF status is applied from the CQ terminal to the external device connected to channel 6.	×	×	○
RYB	Channel 6 (Q) external output signal B	The output ON/OFF status is applied from the Q terminal to the external device connected to channel 6.	○	×	○
RYC	Channel 7 (CQ) external output signal C	The output ON/OFF status is applied from the CQ terminal to the external device connected to channel 7.	×	×	○
RYD	Channel 7 (Q) external output signal D	The output ON/OFF status is applied from the Q terminal to the external device connected to channel 7.	○	×	○
RYE	Channel 8 (CQ) external output signal E	The output ON/OFF status is applied from the CQ terminal to the external device connected to channel 8.	×	×	○
RYF	Channel 8 (Q) external output signal F	The output ON/OFF status is applied from the Q terminal to the external device connected to channel 8.	○	×	○

## Channel n (CQ/Q) I/O switching command (RY10 to RY1F)

This command changes the mode of each channel to the SIO mode (digital output) or SIO mode (digital input). (n = 1 to 8)

Devices available for this signal differ depending on the mode.

○: Available, ×: Not available

Device number	Signal name	Description	Mode		
			IO-Link mode	SIO mode (digital input)	SIO mode (digital output)
RY10	Channel 1 (CQ) I/O switching command	<ul style="list-style-type: none"> <li>• ON: Sets the CQ terminal of channel 1 to the SIO mode (digital output).</li> <li>• OFF: Sets the CQ terminal of channel 1 to the SIO mode (digital input).</li> </ul>	×	○	○
RY11	Channel 1 (Q) I/O switching command	<ul style="list-style-type: none"> <li>• ON: Sets the Q terminal of channel 1 to the SIO mode (digital output).</li> <li>• OFF: Sets the Q terminal of channel 1 to the SIO mode (digital input).</li> </ul>	○	○	○
RY12	Channel 2 (CQ) I/O switching command	<ul style="list-style-type: none"> <li>• ON: Sets the CQ terminal of channel 2 to the SIO mode (digital output).</li> <li>• OFF: Sets the CQ terminal of channel 2 to the SIO mode (digital input).</li> </ul>	×	○	○
RY13	Channel 2 (Q) I/O switching command	<ul style="list-style-type: none"> <li>• ON: Sets the Q terminal of channel 2 to the SIO mode (digital output).</li> <li>• OFF: Sets the Q terminal of channel 2 to the SIO mode (digital input).</li> </ul>	○	○	○
RY14	Channel 3 (CQ) I/O switching command	<ul style="list-style-type: none"> <li>• ON: Sets the CQ terminal of channel 3 to the SIO mode (digital output).</li> <li>• OFF: Sets the CQ terminal of channel 3 to the SIO mode (digital input).</li> </ul>	×	○	○
RY15	Channel 3 (Q) I/O switching command	<ul style="list-style-type: none"> <li>• ON: Sets the Q terminal of channel 3 to the SIO mode (digital output).</li> <li>• OFF: Sets the Q terminal of channel 3 to the SIO mode (digital input).</li> </ul>	○	○	○
RY16	Channel 4 (CQ) I/O switching command	<ul style="list-style-type: none"> <li>• ON: Sets the CQ terminal of channel 4 to the SIO mode (digital output).</li> <li>• OFF: Sets the CQ terminal of channel 4 to the SIO mode (digital input).</li> </ul>	×	○	○
RY17	Channel 4 (Q) I/O switching command	<ul style="list-style-type: none"> <li>• ON: Sets the Q terminal of channel 4 to the SIO mode (digital output).</li> <li>• OFF: Sets the Q terminal of channel 4 to the SIO mode (digital input).</li> </ul>	○	○	○
RY18	Channel 5 (CQ) I/O switching command	<ul style="list-style-type: none"> <li>• ON: Sets the CQ terminal of channel 5 to the SIO mode (digital output).</li> <li>• OFF: Sets the CQ terminal of channel 5 to the SIO mode (digital input).</li> </ul>	×	○	○
RY19	Channel 5 (Q) I/O switching command	<ul style="list-style-type: none"> <li>• ON: Sets the Q terminal of channel 5 to the SIO mode (digital output).</li> <li>• OFF: Sets the Q terminal of channel 5 to the SIO mode (digital input).</li> </ul>	○	○	○
RY1A	Channel 6 (CQ) I/O switching command	<ul style="list-style-type: none"> <li>• ON: Sets the CQ terminal of channel 6 to the SIO mode (digital output).</li> <li>• OFF: Sets the CQ terminal of channel 6 to the SIO mode (digital input).</li> </ul>	×	○	○
RY1B	Channel 6 (Q) I/O switching command	<ul style="list-style-type: none"> <li>• ON: Sets the Q terminal of channel 6 to the SIO mode (digital output).</li> <li>• OFF: Sets the Q terminal of channel 6 to the SIO mode (digital input).</li> </ul>	○	○	○
RY1C	Channel 7 (CQ) I/O switching command	<ul style="list-style-type: none"> <li>• ON: Sets the CQ terminal of channel 7 to the SIO mode (digital output).</li> <li>• OFF: Sets the CQ terminal of channel 7 to the SIO mode (digital input).</li> </ul>	×	○	○
RY1D	Channel 7 (Q) I/O switching command	<ul style="list-style-type: none"> <li>• ON: Sets the Q terminal of channel 7 to the SIO mode (digital output).</li> <li>• OFF: Sets the Q terminal of channel 7 to the SIO mode (digital input).</li> </ul>	○	○	○
RY1E	Channel 8 (CQ) I/O switching command	<ul style="list-style-type: none"> <li>• ON: Sets the CQ terminal of channel 8 to the SIO mode (digital output).</li> <li>• OFF: Sets the CQ terminal of channel 8 to the SIO mode (digital input).</li> </ul>	×	○	○
RY1F	Channel 8 (Q) I/O switching command	<ul style="list-style-type: none"> <li>• ON: Sets the Q terminal of channel 8 to the SIO mode (digital output).</li> <li>• OFF: Sets the Q terminal of channel 8 to the SIO mode (digital input).</li> </ul>	○	○	○

## Display LED1, LED2 (RY20, RY21)

Turn on or off these signals in combination to change the status of DISPLAY1 LED and DISPLAY2 LED.

Display LED1, LED2 (RY20)	Display LED1, LED2 (RY21)	Status
ON	OFF	DISPLAY1 LED and DISPLAY2 LED are on in red.
OFF	ON	DISPLAY1 LED and DISPLAY2 LED are on in green.
ON	ON	DISPLAY1 LED and DISPLAY2 LED are on in orange.
OFF	OFF	DISPLAY1 LED and DISPLAY2 LED are off.

## Display lock (RY22)

Set it to ON to lock the operation on the display part in edit mode. In the locked state, a key icon is displayed on the LCD screen. (🔑 Page 18 Network configuration)

## Channel n mode switching command (RY30 to RY37)

This command changes the mode of each channel. (n = 1 to 8)

Channel n mode switching command (RY30 to RY37)	Status
ON	Set to the IO-Link mode.*1
OFF	Set to the SIO mode.

\*1 If the IO-Link mode is specified, the CQ terminal of the channel is set to the IO-Link mode and starts IO-Link communication. The Q terminal remains in SIO mode.

## Channel n event deletion (RY38 to RY3F)

Set it to ON to delete all the events that have occurred on each channel. (n = 1 to 8)

If it is held to ON, new events that occur will also be deleted automatically.

# Appendix 2 Remote Registers

This section lists remote registers for a master/local module.

The following shows an assignment example of remote registers with the remote registers of the IO-Link module assigned to RWr0 to RWr83 and RWw0 to RWw83. (This example assumes that IO-Link devices with the process data size of 16 words are connected to all the channels from 1 to 8 of the IO-Link module.)

The remote registers are assigned in station-based units.

Remote register (RWr) is the information input from the IO-Link module to the master/local module.

Remote register (RWw) is the information output from the master/local module to the IO-Link module.



Do not read or write data from/to any "Use prohibited" remote registers. Doing so may cause an accident due to incorrect output or malfunction.

## List of remote register

Remote register (RWr)		Remote register (RWw)	
Signal direction: IO-Link module → Master/local module		Signal direction: Master/local module → IO-Link module	
Device number	Name	Device number	Name
RWr0	Module status area	RWw0	Module operation area
RWr1	Error code	RWw1	Use prohibited
RWr2	Warning code	RWw2	Use prohibited
RWr3	Use prohibited	RWw3	Use prohibited
RWr4 to RWr4+(n1-1)	Channel 1 input process data • n1: Data size of channel 1	RWw4 to RWw4+(n1-1)	Channel 1 output process data • n1: Data size of channel 1
RWr+(m2+1) to RWr(m2+1)+(n2-1)	Channel 2 input process data • m2: RWr4+(n1-1) • n2: Data size of channel 2	RWw+(m2+1) to RWw(m2+1)+(n2-1)	Channel 2 output process data • m2: RWw4+(n1-1) • n2: Data size of channel 2
RWr+(m3+1) to RWr(m3+1)+(n3-1)	Channel 3 input process data • m3: RWr(m2+1)+(n2-1) • n3: Data size of channel 3	RWw+(m3+1) to RWw(m3+1)+(n3-1)	Channel 3 output process data • m3: RWw(m2+1)+(n2-1) • n3: Data size of channel 3
RWr+(m4+1) to RWr(m4+1)+(n4-1)	Channel 4 input process data • m4: RWr(m3+1)+(n3-1) • n4: Data size of channel 4	RWw+(m4+1) to RWw(m4+1)+(n4-1)	Channel 4 output process data • m4: RWw(m3+1)+(n3-1) • n4: Data size of channel 4
RWr+(m5+1) to RWr(m5+1)+(n5-1)	Channel 5 input process data • m5: RWr(m4+1)+(n4-1) • n5: Data size of channel 5	RWw+(m5+1) to RWw(m5+1)+(n5-1)	Channel 5 output process data • m5: RWw(m4+1)+(n4-1) • n5: Data size of channel 5
RWr+(m6+1) to RWr(m6+1)+(n6-1)	Channel 6 input process data • m6: RWr(m5+1)+(n5-1) • n6: Data size of channel 6	RWw+(m6+1) to RWw(m6+1)+(n6-1)	Channel 6 output process data • m6: RWw(m5+1)+(n5-1) • n6: Data size of channel 6
RWr+(m7+1) to RWr(m7+1)+(n7-1)	Channel 7 input process data • m7: RWr(m6+1)+(n6-1) • n7: Data size of channel 7	RWw+(m7+1) to RWw(m7+1)+(n7-1)	Channel 7 output process data • m7: RWw(m6+1)+(n6-1) • n7: Data size of channel 7
RWr+(m8+1) to RWr(m8+1)+(n8-1)	Channel 8 input process data • m8: RWr(m7+1)+(n7-1) • n8: Data size of channel 8	RWw+(m8+1) to RWw(m8+1)+(n8-1)	Channel 8 output process data • m8: RWw(m7+1)+(n7-1) • n8: Data size of channel 8

**Ex.**

The following shows the remote register areas when IO-Link devices with the process data size of 16 words are connected to all the channels from 1 to 8 of the IO-Link module.

Remote register (RWr)		Remote register (RWw)	
Signal direction: IO-Link module → Master/local module		Signal direction: Master/local module → IO-Link module	
Device number	Name	Device number	Name
RWr0	Module status area	RWw0	Module operation area
RWr1	Error code	RWw1	Use prohibited
RWr2	Warning code	RWw2	Use prohibited
RWr3	Use prohibited	RWw3	Use prohibited
RWr4 to RWr13	Channel 1 input process data	RWw4 to RWw13	Channel 1 output process data
RWr14 to RWr23	Channel 2 input process data	RWw14 to RWw23	Channel 2 output process data
RWr24 to RWr33	Channel 3 input process data	RWw24 to RWw33	Channel 3 output process data
RWr34 to RWr43	Channel 4 input process data	RWw34 to RWw43	Channel 4 output process data
RWr44 to RWr53	Channel 5 input process data	RWw44 to RWw53	Channel 5 output process data
RWr54 to RWr63	Channel 6 input process data	RWw54 to RWw63	Channel 6 output process data
RWr64 to RWr73	Channel 7 input process data	RWw64 to RWw73	Channel 7 output process data
RWr74 to RWr83	Channel 8 input process data	RWw74 to RWw83	Channel 8 output process data

### Details of Module status area (RWr0) and Module operation area (RWw0)

Module status area (RWr0)	Name	Module operation area (RWw0)	Name
RWr0.b0	Use prohibited	RWw0.b0	Use prohibited
RWr0.b1		RWw0.b1	
RWr0.b2		RWw0.b2	
RWr0.b3		RWw0.b3	
RWr0.b4		RWw0.b4	
RWr0.b5		RWw0.b5	
RWr0.b6		RWw0.b6	
RWr0.b7		RWw0.b7	
RWr0.b8	Initial processing request flag	RWw0.b8	Initial processing completion flag
RWr0.b9	Operation condition setting completion flag	RWw0.b9	Operation condition setting request flag
RWr0.b10	Error status flag	RWw0.b10	Error clear request flag
RWr0.b11	Remote READY	RWw0.b11	Use prohibited
RWr0.b12	Warning status flag	RWw0.b12	
RWr0.b13	Use prohibited	RWw0.b13	
RWr0.b14		RWw0.b14	
RWr0.b15		RWw0.b15	

**A**

# Details of Remote Registers

## Module status area (RWr0)

### Initial processing request flag (RWr0.b8)

The operations of Initial processing request flag (RWr0.b8) and Initial processing completion flag (RWw0.b8) vary depending on the setting value of Initial operation setting.

For details on the initial operation setting, refer to the following.

☞ Page 84 Initial operation setting

- When With initial processing is set

After the module is powered on, Initial processing request flag (RWr0.b8) turns on. Create a program where initial processing is executed by using Initial processing request flag (RWr0.b8) and Initial processing completion flag (RWw0.b8). When Initial processing completion flag (RWw0.b8) is turned on, Remote READY (RWr0.b11) turns on. Also when Initial processing completion flag (RWw0.b8) is turned on, Initial processing request flag (RWr0.b8) turns off.



When setting parameters using Initial processing request flag (RWr0.b8) as an interlock as shown in the program example, set "Initial operation setting" to "With initial processing". After that, perform initial processing and check that Remote READY (RWr0.b11) is on.

For program examples of initial processing, refer to the following.

☞ Page 105 Program example

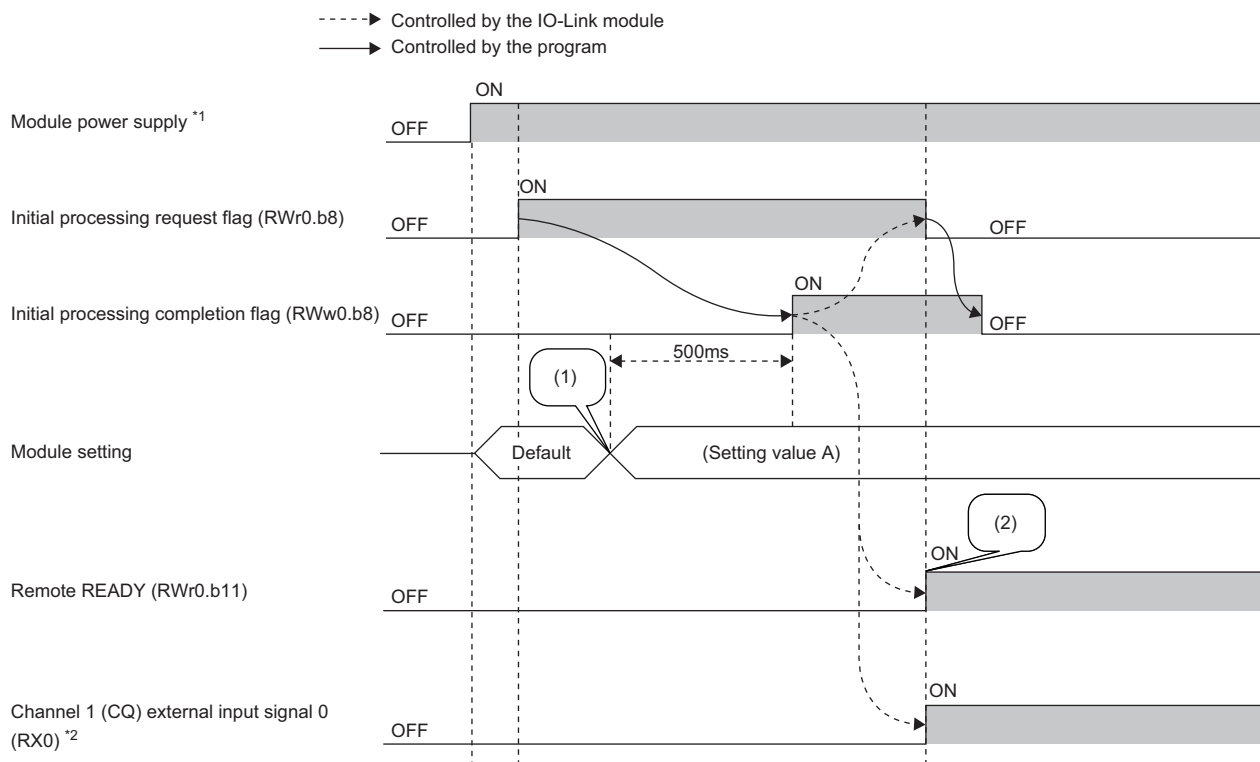

(1) The setting value is changed by a program.

(2) The operation starts with the setting value A.

\*1 When data link starts at the same time of when the module is powered on

\*2 When an external input device connected to X0 is on

- When "Without initial processing" is set

Initial processing request flag (RWr0.b8) does not turn on. The IO-Link module becomes operable (the update of external I/O becomes enabled) without Initial processing completion flag (RWw0.b8) being turned on. When the module is powered on, Remote READY (RWr0.b11) turns on.

Module parameter settings are read from the data storage.

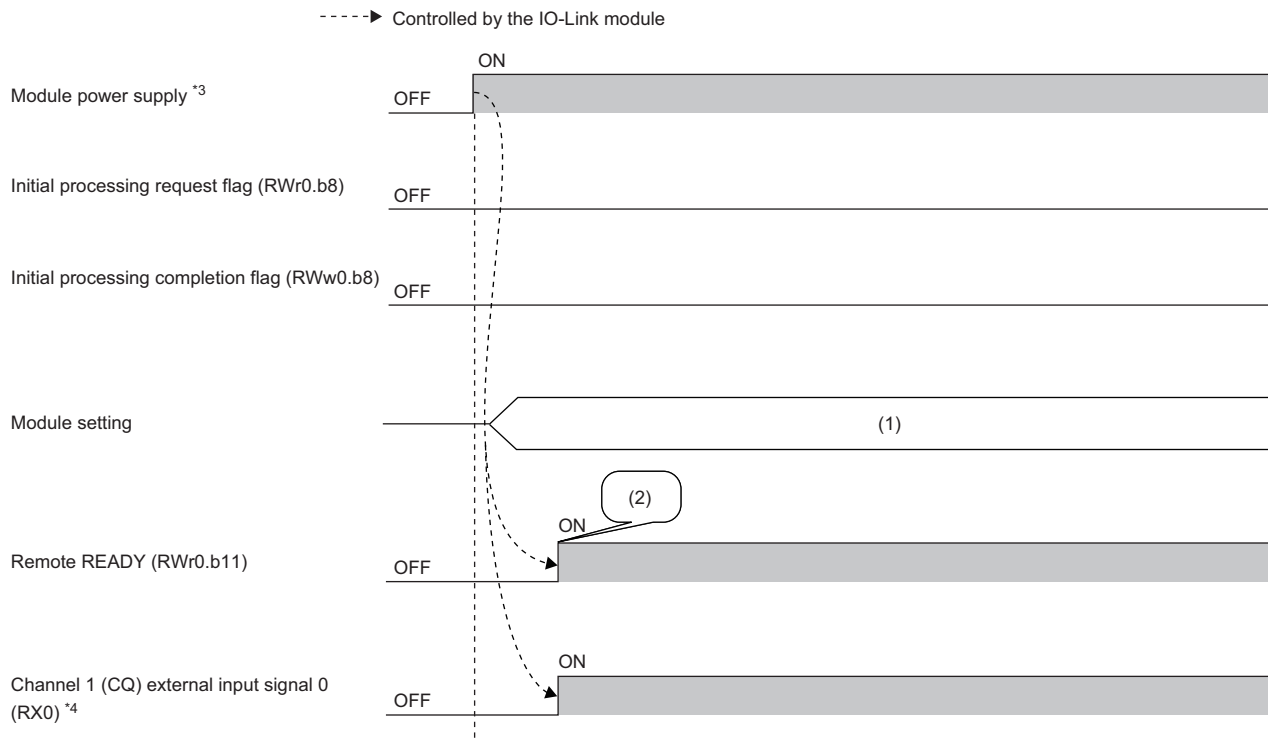

(1) Module parameters in the data storage

(2) Read module parameters in the data storage and start the operation.

\*3 When data link starts at the same time of when the module is powered on

\*4 When an external input device connected to X0 is on



## ■ Operation condition setting completion flag (RWr0.b9)

To change the module settings during operation, write the setting data and then turn on the Operation condition setting request flag (RWw0.b9). After the operation condition is changed, Operation condition setting completion flag (RWr0.b9) turns on.

When the operation condition setting is requested, Warning code (RWr2) is set to 0000H and Warning status flag (RWr0.b12) is turned off.

If the cause of the current error has been removed, Error code (RWr1) is set to 0000H, and Error status flag (RWr0.b10) is turned off.

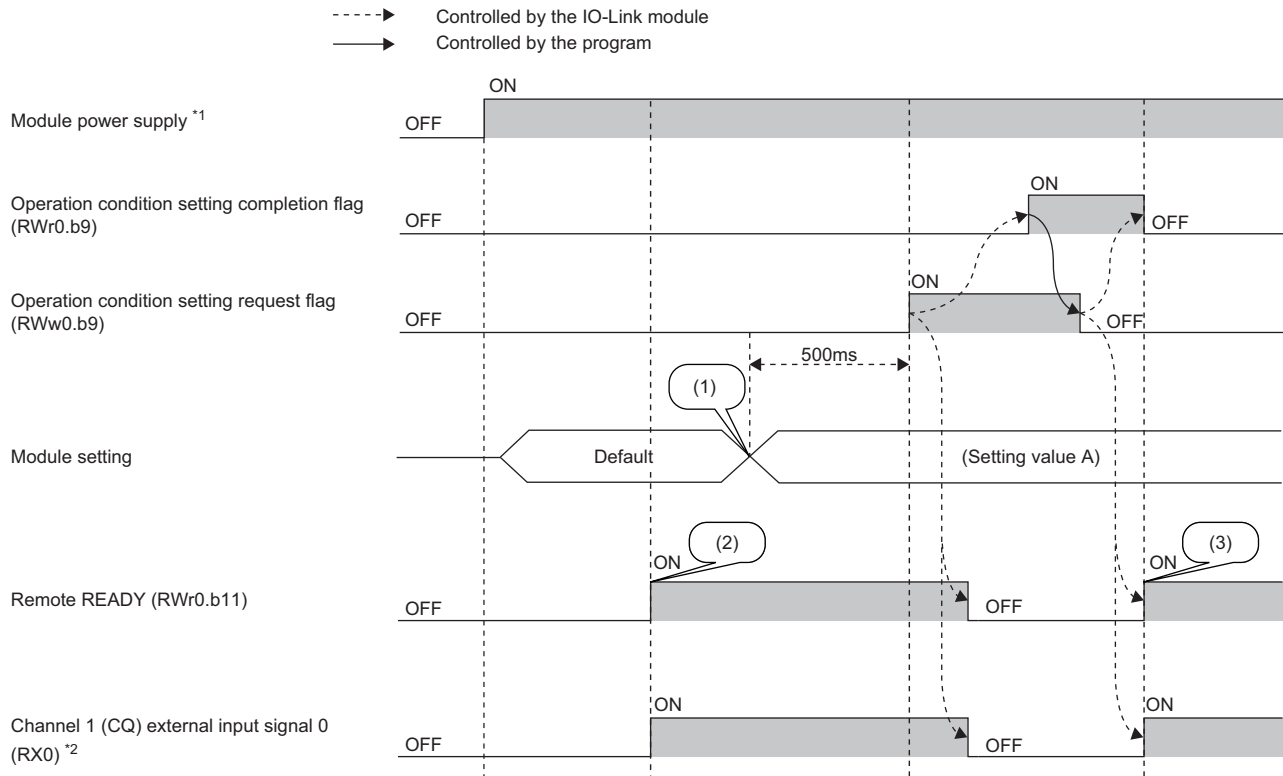

(1) The setting value is changed by a program.

(2) The operation starts with the default settings.

(3) The operation starts with the parameter setting value A.

\*1 When data link starts at the same time of when the module is powered on

\*2 When an external input device connected to X0 is on

## ■ Error status flag (RWr0.b10)

Error status flag (RWr0.b10) turns on when a moderate error or major error occurs. Removing the cause of the error (excluding a watchdog timer error) and turning on Error clear request flag (RWw0.b10) resets Error code (RWr1) to 0000H and turns off the Error status flag (RWr0.b10).

If Error clear request flag (RWw0.b10) is turned on before removing the error cause, the error will be cleared but the Error status flag (RWr0.b10) will be turned on again as long as the error cause remains.

When a major error has occurred, the error clear operation is not available.

Multiple errors occurring on multiple channels can be cleared collectively.



### ■Remote READY (RWr0.b11)

This signal is used as an interlock condition when the CC-Link IE Field Network master station reads/writes data from/to the remote registers and other areas of the IO-Link module.

With "Initial operation setting" being set to "With initial processing", Remote READY (RWr0.b11) turns on when initial processing is completed after powering on of the module.

With "Initial operation setting" being set to "Without initial processing", Remote READY (RWr0.b11) turns on after powering on of the module.

When Operation condition setting request flag (RWw0.b9) turns on, Remote READY (RWr0.b11) turns off.

For details on the initial operation setting, refer to the following.

 Page 84 Initial operation setting

### ■Warning status flag (RWr0.b12)

Warning status flag (RWr0.b12) turns on when a minor error occurs.

After the cause of the minor error is eliminated, the value in Warning code (RWr2) is cleared automatically (0000H is stored) and Warning status flag (RWr0.b12) turns off.

### Error code (RWr1)

The latest error code is stored into RWr1 when a moderate error or major error occurs (excluding a watchdog timer error). Turning on the Error clear request flag (RWw0.b10) after eliminating the cause of the error clears the error code.

### Warning code (RWr2)

The latest warning code is stored into RWr2 when a minor error occurs.

After the cause of the minor error is eliminated, the latest warning code is automatically cleared.

### Channel n input process data (from RWr4)

The input process data depends on the IO-Link device used.

For details, refer to the manual of the IO-Link device used.

#### Point

Because the process data size varies depending on the connected IO-Link device, specify the value not less than the total process data size of the IO-Link device used. ( Page 86 Process data size)

## Module operation area (RWw0)

### ■Initial processing completion flag (RWw0.b8)

Turning on this flag completes the initial processing and turns on Remote READY (RWr0.b11).

For the timing of turning the flag on and off, refer to the following.

 Page 140 Initial processing request flag (RWr0.b8)

### ■Operation condition setting request flag (RWw0.b9)

Write the setting data and then turn on Operation condition setting request flag (RWw0.b9). After the operation condition is changed, Operation condition setting completion flag (RWr0.b9) turns on.

For the timing of turning the flag on and off, refer to the following.

 Page 142 Operation condition setting completion flag (RWr0.b9)

#### Point

- Turning on Operation condition setting request flag (RWw0.b9) stores 0000H in Warning code (RWr2) and turns off Warning status flag (RWr0.b12).
- When a major error or a moderate error occurs and the error cause is eliminated, turning on Operation condition setting request flag (RWw0.b9) stores 0000H in Error code (RWr1) and turns off Error status flag (RWr0.b10).

### ■Error clear request flag (RWw0.b10)

Use this flag to clear Error status flag (RWr0.b10) and Error code (RWr1).

- When a moderate error occurs

When Error clear request flag (RWw0.b10) is turned on after the cause of the error is eliminated, the error status is cleared and Error status flag (RWr0.b10) turns off.

If Error clear request flag (RWw0.b10) is turned off before Error status flag (RWr0.b10) turns off, Error status flag (RWr0.b10) does not turn off.

- When a major error occurs

Error status flag (RWr0.10) does not turn off even if Error clear request flag (RWw0.b10) is turned on and off.

## Channel n output process data (from RWw4)

The output process data depends on the IO-Link device used.

For details, refer to the manual of the IO-Link device used.

#### Point

Because the process data size varies depending on the connected IO-Link device, specify the value not less than the total process data size of the IO-Link device used. ( Page 86 Process data size)

# Appendix 3 Processing Time

The transmission delay time of the IO-Link module is a total of the following times.

- CPU module sequence scan time
- CC-Link IE Field Network link scan time
- IO-Link module internal processing cycle
- IO-Link cycle time

For details on the CPU module sequence scan time, refer to the following.

 User's manual for the CPU module used

For details on the CC-Link IE Field Network link scan time, refer to the following.

 User's manual for the master/local module used

## IO-Link module internal processing cycle

The IO-Link module internal processing cycle is fixed to 2ms.

## IO-Link cycle time

The IO-Link cycle time is determined by the IO-Link device connected.

For details, refer to the manual of the IO-Link device.

**Ex.**

The transmission delay time with an IO-Link device connected to channel 1 of the IO-Link module is as follows.

Item	Condition	Processing time
CPU module sequence scan time	—	0.3ms
CC-Link IE Field Network link scan time	High-speed mode, single station, RX/Ry: 32 points, RWw/RWw: 4 points	0.19ms
IO-Link module internal processing cycle	Fixed to 2ms.	2ms
IO-Link cycle time	—	0.4ms

Transmission delay time = 0.3 + 0.19 + 2 + 0.4 = 2.89ms

# Appendix 4 EMC and Low Voltage Directives

In each country, laws and regulations concerning electromagnetic compatibility (EMC) and electrical safety are enacted. For the products sold in the European countries, compliance with the EU's EMC Directive has been a legal obligation as EMC regulation since 1996, as well as the EU's Low Voltage Directive as electrical safety regulation since 1997.

Manufacturers who recognize their products are compliant with the EMC and Low Voltage Directives are required to attach a "CE marking" on their products in European countries.

In some other countries and regions, manufacturers are required to make their products compliant with applicable laws or regulations and attach a certification mark on the products as well (such as UK Conformity Assessed (UKCA) marking in the UK, and Korea Certification (KC) marking in South Korea).

Each country works to make their regulatory requirements consistent across countries based on international standards.

When the requirements are consistent, measures to comply with the EMC and electrical safety regulations become common across countries.

The UK and South Korea have enacted EMC regulations whose requirements are consistent with those of the EMC Directive. The UK has also enacted electrical safety regulations whose requirements are consistent with those of the Low Voltage Directive. In this section, the requirements of the EMC and Low Voltage Directives are described as examples of those of the EMC and electrical safety regulations.

## Measures to comply with the EMC Directive

The EMC Directive specifies that "products placed on the market must be so constructed that they do not cause excessive electromagnetic interference (emissions) and are not unduly affected by electromagnetic interference (immunity)".

This section summarizes the precautions on compliance with the EMC Directive of the machinery constructed with the module.

These precautions are based on the requirements and the standards of the regulation, however, it does not guarantee that the entire machinery constructed according to the descriptions will comply with abovementioned directives.

The method and judgment for complying with the EMC Directive must be determined by the person who constructs the entire machinery.

### EMC Directive related standards

#### ■ Emission requirements

Specifications	Test item	Test details	Standard value
EN61131-2: 2007	CISPR16-2-3 Radiated emission	Radio waves from the product are measured.	<ul style="list-style-type: none"><li>• 30M-230MHz QP: 40dB<math>\mu</math>V/m (10m in measurement range)<sup>*1</sup></li><li>• 230M-1000MHz QP: 47dB<math>\mu</math>V/m (10m in measurement range)</li></ul>
	CISPR16-2-1, CISPR16-1-2 Conducted emission	Noise from the product to the power line is measured.	<ul style="list-style-type: none"><li>• 150k-500kHz QP: 79dB, Mean: 66dB<sup>*1</sup></li><li>• 500k-30MHz QP: 73dB, Mean: 60dB</li></ul>

\*1 QP: Quasi-peak value, Mean: Average value

## ■ Immunity requirements

Specifications	Test item	Test details	Standard value
EN61131-2: 2007	EN61000-4-2 Electrostatic discharge immunity	Immunity test in which electrostatic is applied to the cabinet of the equipment.	<ul style="list-style-type: none"> <li>• 8kV Air discharge</li> <li>• 4kV Contact discharge</li> </ul>
	EN61000-4-3 Radiated, radio-frequency, electromagnetic field immunity	Immunity test in which electric fields are irradiated to the product.	<ul style="list-style-type: none"> <li>• 80M-1000MHz: 10V/m</li> <li>• 1.4G-2.0GHz: 3V/m</li> <li>• 2.0G-2.7GHz: 1V/m</li> </ul>
	EN61000-4-4 Electrical fast transient/ burst immunity	Immunity test in which burst noise is applied to the power line and signal line.	<ul style="list-style-type: none"> <li>• AC/DC main power, I/O power, AC I/O (unshielded): 2kV</li> <li>• DC I/O, analog, communication: 1kV</li> </ul>
	EN61000-4-5 Surge immunity	Immunity test in which lightning surge is applied to the power line and signal line.	<ul style="list-style-type: none"> <li>• AC power line, AC I/O power, AC I/O (unshielded): 2kV CM, 1kV DM</li> <li>• DC power line, DC I/O power: 0.5kV CM, DM</li> <li>• DC I/O, AC I/O (shielded), analog<sup>*1</sup>, communication: 1kV CM</li> </ul>
	EN61000-4-6 Immunity to conducted disturbances, induced by radio-frequency fields	Immunity test in which high frequency noise is applied to the power line and signal line	0.15M-80MHz, 80% AM modulation @1kHz, 10Vrms
	EN61000-4-8 Power-frequency magnetic field immunity	Immunity test in which the product is installed in inductive magnetic field	50Hz/60Hz, 30A/m
	EN61000-4-11 Voltage dips and interruption immunity	Immunity test in which power supply voltage is momentarily interrupted	<ul style="list-style-type: none"> <li>• Apply at 0%, 0.5 cycles and zero-cross point</li> <li>• 0%, 250/300 cycles (50/60Hz)</li> <li>• 40%, 10/12 cycles (50/60Hz)</li> <li>• 70%, 25/30 cycles (50/60Hz)</li> </ul>

\*1 The accuracy of an analog-digital converter module may temporarily vary within  $\pm 10\%$ .

## External power supply

- Use a CE-marked product for an external power supply and always ground the FG metal fitting. (External power supply used for the tests conducted by Mitsubishi: TDK-Lambda DLP-120-24-1, IDEC PS5R-SF24, PS5R-F24)
- Use a power cable of 10m or shorter when connecting it to the module power supply terminal.
- Use a power cable of 30m or shorter when connecting it to the load power supply for output part.

## Others

### ■ Ferrite core

A ferrite core has the effect of reducing radiated noise in the 30MHz to 100MHz band.

It is recommended to attach ferrite cores if shielded cables coming out of the control panel do not provide sufficient shielding effects.

Note that the ferrite cores must be attached at the position closest to the cable hole inside the control panel. If attached at an improper position, the ferrite core will not produce any effect.

For the FG metal fitting that is connected to the load power supply of an I/O module and CC-Link IE Field Network cables, attach a ferrite core 4cm away from the module.

(Ferrite core used for the tests conducted by Mitsubishi: NEC TOKIN ESD-SR-250, TDK ZCAT3035-1330)

Ex.

Example

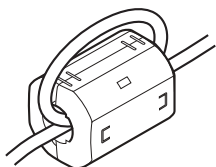

### ■ Noise filter (power supply line filter)

A noise filter is a component which has an effect on conducted noise. Attaching the filter can suppress more noise. (The noise filter has the effect of reducing conducted noise of 10MHz or less.)

Connect a noise filter to the load power supply of an I/O module. Use a noise filter with the damping characteristics equivalent to those of MA1206 (manufactured by TDK-Lambda Corporation). Note that a noise filter is not required if the module is used in Zone A defined in EN61131-2.

The precautions for attaching a noise filter are described below.

- Do not bundle the cables on the input side and output side of the noise filter. If bundled, the output side noise will be induced into the input side cables from which the noise was filtered.

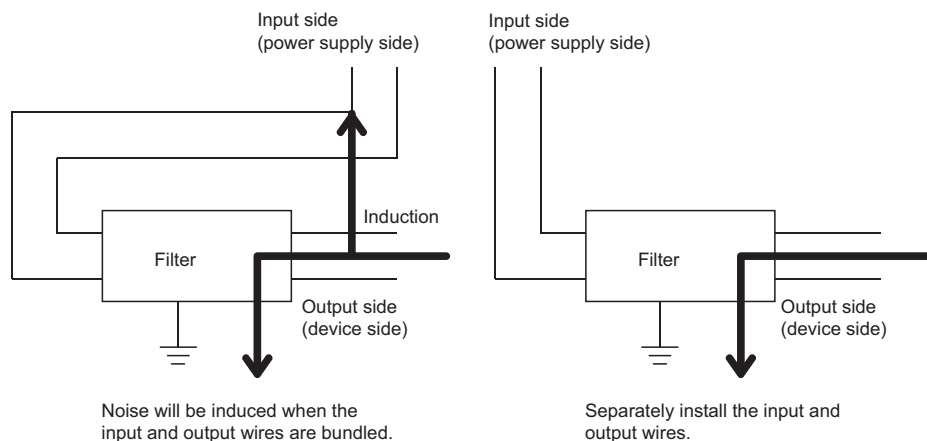

- Ground the noise filter grounding terminal to the control panel with the shortest cable possible (approx. 10cm).

## Requirements to compliance with the Low Voltage Directive

---

The IO-Link module operates at the rated voltage of 24VDC.

The Low Voltage Directive is not applied to the modules that operate at the rated voltage of less than 50VAC and 75VDC.

# Appendix 5 How to Check the Version

The version of the IO-Link module is indicated at the bottom right corner on the front of the module.

The major version of the IO-Link module is indicated at the bottom right corner on the front of the module.

For details, refer to the following.

☞ Page 17 Operation specifications of the display part

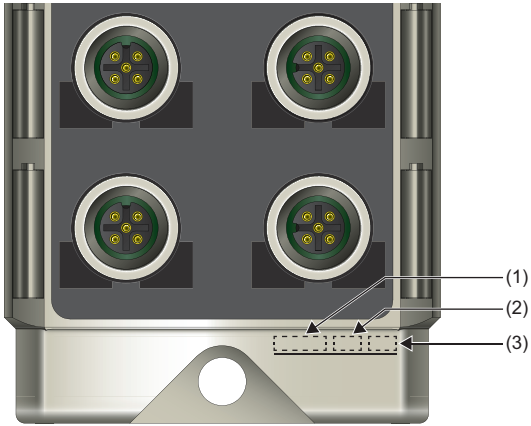

- (1) Lot number
- (2) Hardware version
- (3) Firmware version



# Appendix 6 External Dimensions

The following figures show the external dimensions of the IO-Link module.

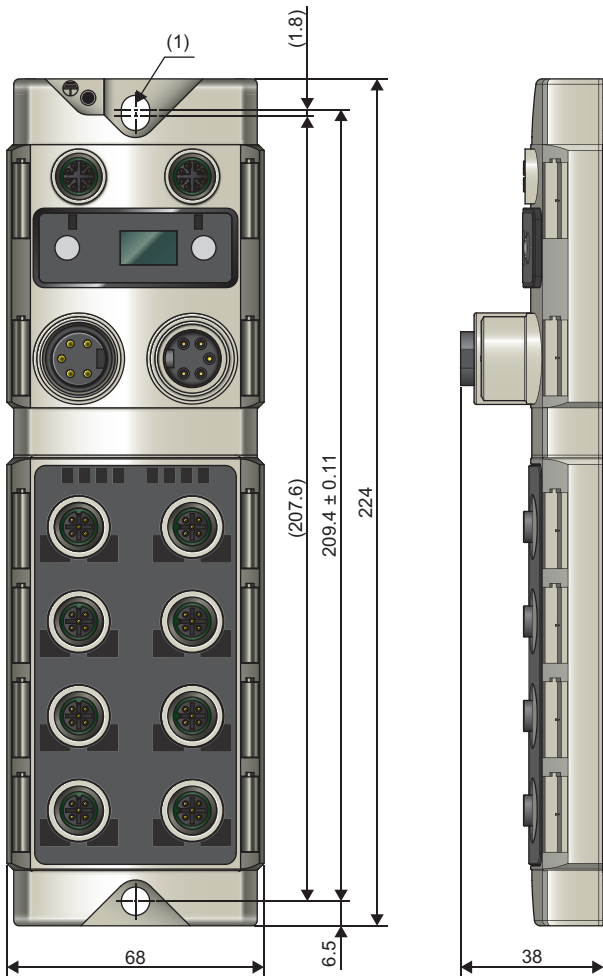

(1) Fixing hole (M6 mounting screw) × 2

(Unit: mm)



# Appendix 7 Additional or Changed Functions

---

## Additional functions

---

This section lists the functions added to the IO-Link module.

Added/Changed function	Supported firmware version
CC-Link IE Field Network diagnostics	2.0.2 or later
IO-Link device parameter settings configured using FDT	2.0.2 or later
Output HOLD/CLEAR setting function during IO-Link mode	2.0.2 or later

# Appendix 8 WEEE Directive

---

The Directive on Waste Electrical and Electronic Equipment (WEEE Directive) is an EU directive which aims to reduce the amount of waste electrical and electronic equipment (WEEE) by suppressing the generation of WEEE and by encouraging reuse and recycling. EU Member States and manufacturers are obliged to establish a WEEE collection and recycling system and bear the costs. For this product, the directive's symbol mark is indicated on this manual as it is difficult to attach the symbol mark to the product itself and to the manual included with the product.

## Disposal precautions

---

This symbol mark means that electrical and electronic equipment, at their end-of-life, should be disposed of separately from your household waste.



This symbol mark is for EU countries only.

This symbol mark is according to the directive 2012/19/EU Article 14 Information for users and Annex IX.

## Exportation precautions

---

At exportation of this product to EU member states, customers (and/or importers in EU member states) are needed to comply with the WEEE Directive (product registration, sales volume reporting, etc.) depending on circumstances.

A

# INDEX

## A

Applicable master station . . . . . 29

## C

Channel n (CQ/Q) external input signal 0 to F (RX0 to RXF) . . . . . 131  
Channel n (CQ/Q) external output signal 0 to F (RY0 to RYF) . . . . . 135  
Channel n (CQ/Q) I/O switching command (RY10 to RY1F) . . . . . 136  
Channel n (CQ/Q) short-circuit detection flag (RX10 to RX1F) . . . . . 132  
Channel n (L+) short-circuit detection flag (RX20 to RX27) . . . . . 133  
Channel n communication start flag (RX30 to RX37) . . . . . 134  
Channel n data valid flag (RX40 to RX47) . . . . . 134  
Channel n event deletion (RY38 to RY3F) . . . . . 137  
Channel n event flag (RX38 to RX3F) . . . . . 134  
Channel n input process data (from RWr4) . . . . . 143  
Channel n mode switching command (RY30 to RY37) . . . . . 137  
Channel n output process data (from RWw4) . . . . . 144  
Connecting the Ethernet cable . . . . . 38  
Connecting the IO-Link cable . . . . . 41  
CQ LED . . . . . 16

## D

Data storage configuration . . . . . 88  
Data storage content . . . . . 89  
Data that can be read and written in transient transmission . . . . . 83  
Derating chart . . . . . 24  
Device validation . . . . . 87  
Disconnecting the Ethernet cable . . . . . 40  
Disconnecting the IO-Link cable . . . . . 42  
Display LED1, LED2 (RY20, RY21) . . . . . 136  
Display lock (RY22) . . . . . 137  
Display part . . . . . 17  
DISPLAY1 LED . . . . . 15  
DISPLAY2 LED . . . . . 15

## E

ERR. LED . . . . . 15  
Error clear request flag (RWw0.b10) . . . . . 144  
Error code (RWr1) . . . . . 143  
Error status flag (RWr0.b10) . . . . . 142  
Event data . . . . . 92  
External connection . . . . . 23

## I

Initial operation setting . . . . . 84  
Initial processing completion flag (RWw0.b8) . . . . . 144  
Initial processing request flag (RWr0.b8) . . . . . 140  
IO-Link cycle time . . . . . 145  
IO-Link device . . . . . 12  
IO-Link module . . . . . 12

IO-Link module identification data . . . . . 84  
IO-Link module internal processing cycle . . . . . 145  
ISDU . . . . . 12,92

## L

L ER LED(P1) . . . . . 16  
L ER LED(P2) . . . . . 16  
LINK LED(P1) . . . . . 16  
LINK LED(P2) . . . . . 16

## M

Module operation area (RWw0) . . . . . 144  
Module status area (RWr0) . . . . . 140

## N

Number of ON times . . . . . 86

## O

Operation condition setting completion flag (RWr0.b9) . . . . . 142  
Operation condition setting request flag (RWw0.b9) . . . . . 144  
Output HOLD/CLEAR setting . . . . . 85

## P

Process data size . . . . . 86  
Program example . . . . . 105,113

## Q

Q LED . . . . . 16

## R

Remote READY (RWr0.b11) . . . . . 143  
RUN LED . . . . . 15

## S

Sink . . . . . 13  
Source . . . . . 13

## U

UA LED . . . . . 15  
UA voltage drop flag (11V or lower) (RX2A) . . . . . 134  
UA voltage drop flag (18V or lower) (RX29) . . . . . 134  
US LED . . . . . 15  
US voltage drop flag (18V or lower) (RX28) . . . . . 134

## W

Warning code (RWr2) . . . . . 143  
Warning status flag (RWr0.b12) . . . . . 143  
Waterproof cap . . . . . 43

# MEMO

---

# REVISIONS

\*The manual number is given on the bottom left of the back cover.

Revision date	*Manual number	Description
June 2017	SH(NA)-081761ENG-A	First edition
April 2018	SH(NA)-081761ENG-B	■Added or modified parts SAFETY PRECAUTIONS, RELEVANT MANUALS, TERMS, Section 2.2, 2.3, Chapter 3, Section 4.1, 6.2, 6.4, 7.1, 7.2, 7.6, Chapter 8, Section 11.1, 11.3, Appendix 5, 7
March 2021	SH(NA)-081761ENG-C	■Added or modified parts SAFETY PRECAUTIONS, CONDITIONS OF USE FOR THE PRODUCT
November 2022	SH(NA)-081761ENG-D	■Added or modified part Appendix 4
January 2023	SH(NA)-081761ENG-E	■Added or modified part Appendix 8

Japanese manual number: SH-081760-E

This manual confers no industrial property rights or any rights of any other kind, nor does it confer any patent licenses. Mitsubishi Electric Corporation cannot be held responsible for any problems involving industrial property rights which may occur as a result of using the contents noted in this manual.

© 2017 MITSUBISHI ELECTRIC CORPORATION

# WARRANTY

---

Please confirm the following product warranty details before using this product.

## **1. Gratis Warranty Term and Gratis Warranty Range**

If any faults or defects (hereinafter "Failure") found to be the responsibility of Mitsubishi occurs during use of the product within the gratis warranty term, the product shall be replaced at no cost via the sales representative.

However, if on-site service are required at domestic or overseas location, expenses to send an engineer will be solely at the customer's discretion. Mitsubishi shall not be held responsible for any re-commissioning, maintenance, or testing on-site that involves replacement of the failed module.

[Gratis Warranty Term]

The gratis warranty term of the product shall be for one year after the date of purchase or delivery to a designated place. Note that after manufacture and shipment from Mitsubishi, the maximum distribution period shall be six (6) months, and the longest gratis warranty term after manufacturing shall be eighteen (18) months. The gratis warranty term of replacement shall not exceed the gratis warranty term before product exchange.

[Gratis Warranty Range]

- (1) The range shall be limited to normal use within the usage state, usage methods and usage environment, etc., which follow the conditions and precautions, etc., given in the instruction manual, user's manual and caution labels on the product.
- (2) Even within the gratis warranty term, replacement shall be charged for in the following cases.
  1. Failure occurring from inappropriate storage or handling, carelessness or negligence by the user. Failure caused by the user's hardware or software design.
  2. Failure caused by unapproved modifications, etc., to the product by the user.
  3. When the Mitsubishi product is assembled into a user's device, Failure that could have been avoided if functions or structures, judged as necessary in the legal safety measures the user's device is subject to or as necessary by industry standards, had been provided.
  4. Failure that could have been avoided if consumable parts (battery, backlight, fuse, etc.) designated in the instruction manual had been correctly serviced or replaced.
  5. Failure caused by external irresistible forces such as fires or abnormal voltages, and Failure caused by force majeure such as earthquakes, lightning, wind and water damage.
  6. Failure caused by reasons unpredictable by scientific technology standards at time of shipment from Mitsubishi.
  7. Any other failure found not to be the responsibility of Mitsubishi or that admitted not to be so by the user.

## **2. Repair and Analysis**

Please note that repairs and failure analysis are refused due to the structure of this product.

## **3. Discontinuation of production**

- (1) Discontinuation of production shall be notified with Mitsubishi Technical Bulletins, etc.
- (2) Product supply (including repair parts) is not available after production is discontinued.

## **4. Overseas service**

Overseas, please contact Mitsubishi's local overseas FA Center.

## **5. Exclusion of loss in opportunity and secondary loss from warranty liability**

Regardless of the gratis warranty term, Mitsubishi shall not be liable for compensation to:

- (1) Damages caused by any cause found not to be the responsibility of Mitsubishi.
- (2) Loss in opportunity, lost profits incurred to the user by Failures of Mitsubishi products.
- (3) Special damages and secondary damages whether foreseeable or not, compensation for accidents, and compensation for damages to products other than Mitsubishi products.
- (4) Replacement by the user, maintenance of on-site equipment, start-up test run and other tasks.

## **6. Changes in product specifications**

The specifications given in the catalogs, manuals or technical documents are subject to change without prior notice.

# TRADEMARKS

---

IO-Link is either a registered trademark or a trademark of PROFIBUS Nutzerorganisation e.V.

The company names, system names and product names mentioned in this manual are either registered trademarks or trademarks of their respective companies.

In some cases, trademark symbols such as <sup>™</sup> or <sup>®</sup> are not specified in this manual.





SH(NA)-081761ENG-E(2301)MEE

MODEL: CCIEF-W-IOLINK-U-E

MODEL CODE: 13JX72

## **MITSUBISHI ELECTRIC CORPORATION**

HEAD OFFICE: TOKYO BLDG., 2-7-3, MARUNOUCHI, CHIYODA-KU, TOKYO 100-8310, JAPAN  
NAGOYA WORKS: 1-14, YADA-MINAMI 5-CHOME, HIGASHI-KU, NAGOYA 461-8670, JAPAN

When exported from Japan, this manual does not require application to the  
Ministry of Economy, Trade and Industry for service transaction permission.

Specifications subject to change without notice.