

<b>HOLD FUNCTION MODULE (PC programmable)</b>	MODEL <b>M6SXF3</b>
---	---------------------

**BEFORE USE ....**

Thank you for choosing M-System. Before use, please check contents of the package you received as outlined below. If you have any problems or questions with the product, please contact M-System's Sales Office or representatives.

**■ PACKAGE INCLUDES:**

Signal conditioner .....(1)

**■ MODEL NO.**

Confirm Model No. marking on the product to be exactly what you ordered.

**■ INSTRUCTION MANUAL**

This manual describes necessary points of caution when you use this product, including installation, connection and basic maintenance procedures.

The M6SXF3 is programmable using the PC Configurator Software. For detailed information on the PC configuration, refer to the M6CFG users manual. The M6CFG PC Configurator Software is downloadable at M-System's web site: <http://www.m-system.co.jp>

**POINTS OF CAUTION**

**■ CONFORMITY WITH EU DIRECTIVES**

- The equipment must be mounted inside a panel.
- The actual installation environments such as panel configurations, connected devices, connected wires, may affect the protection level of this unit when it is integrated in a panel system. The user may have to review the CE requirements in regard to the whole system and employ additional protective measures to ensure the CE conformity.
- Install lightning surge protectors for those wires connected to remote locations.

**■ POWER INPUT RATING & OPERATIONAL RANGE**

- Locate the power input rating marked on the product and confirm its operational range as indicated below:  
24V DC rating: 24V ±10%, approx. 0.5W

**■ GENERAL PRECAUTIONS**

- Before you remove the unit or mount it, turn off the power supply and input signal for safety.

**■ ENVIRONMENT**

- Indoor use.
- When heavy dust or metal particles are present in the air, install the unit inside proper housing with sufficient ventilation.
- Do not install the unit where it is subjected to continuous vibration. Do not subject the unit to physical impact.
- Environmental temperature must be within -20 to +55°C (-4 to +131°F) with relative humidity within 30 to 90% RH in order to ensure adequate life span and operation.

**■ WIRING**

- Do not install cables close to noise sources (relay drive cable, high frequency line, etc.).
- Do not bind these cables together with those in which noises are present. Do not install them in the same duct.

**■ AND ....**

- The unit is designed to function as soon as power is supplied, however, a warm up for 10 minutes is required for satisfying complete performance described in the data sheet.

**COMPONENT IDENTIFICATION**

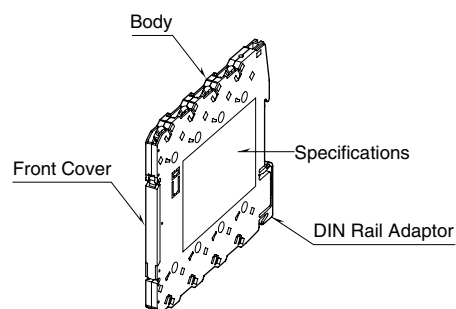

## INSTALLATION

Set the unit so that its DIN rail adapter is at the bottom. When the unit is installed to an Installation Base (model M6SBS), refer to its instruction manual.

### ■ MOUNTING THE UNIT ON A DIN RAIL

- Hang the upper hook at the rear side of unit on the DIN rail.
- Push in the lower in keeping pressing the unit to the DIN rail.

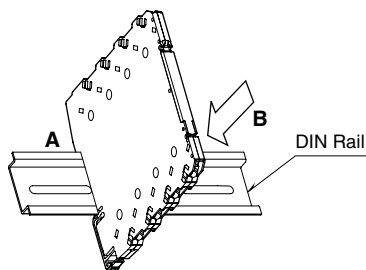

### ■ REMOVING THE UNIT

- Pull down the DIN rail adaptor using a minus screwdriver.
- Pull out the lower part of the unit.
- Remove the upper part from the DIN rail.

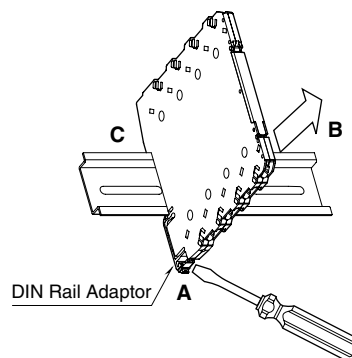

## TERMINAL CONNECTIONS

Connect the unit as in the diagram below or refer to the connection diagram on the side of the unit.

### ■ EXTERNAL DIMENSIONS unit: mm (inch)

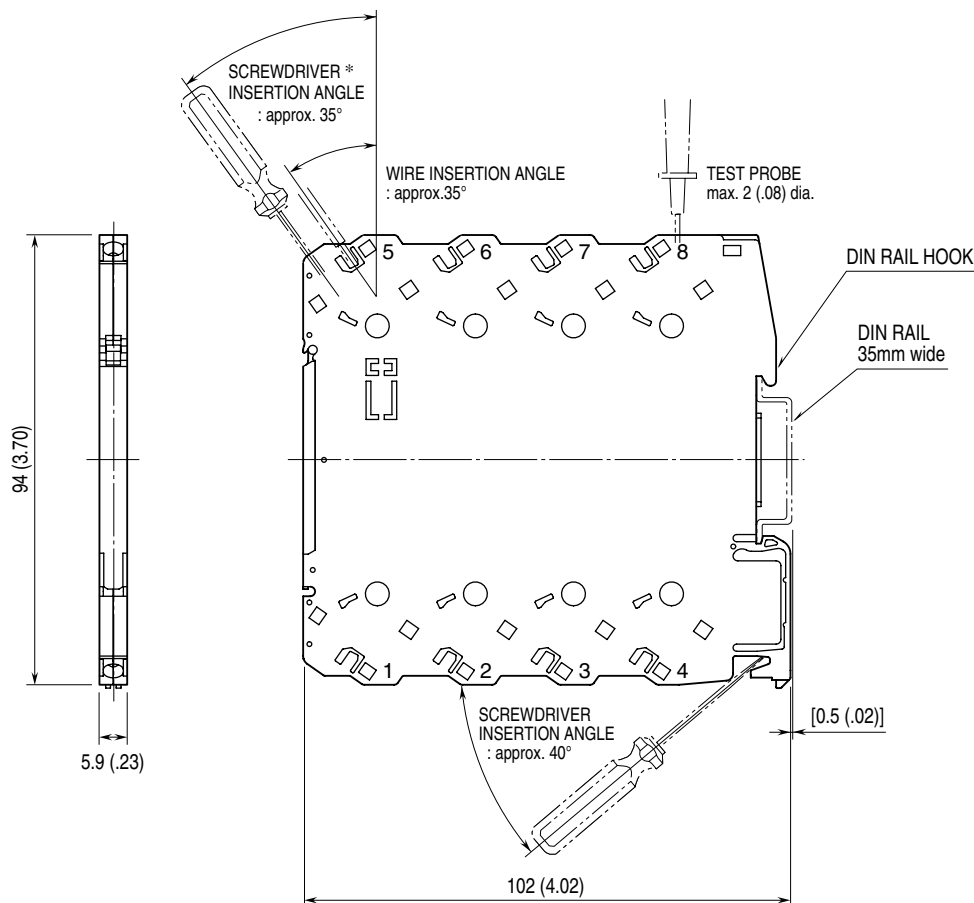

• When mounting, no extra space is needed between units.

\*Use a minus screwdriver: tip width 3.8 mm max., tip thickness 0.5 to 0.6 mm

## ■ CONNECTION DIAGRAM

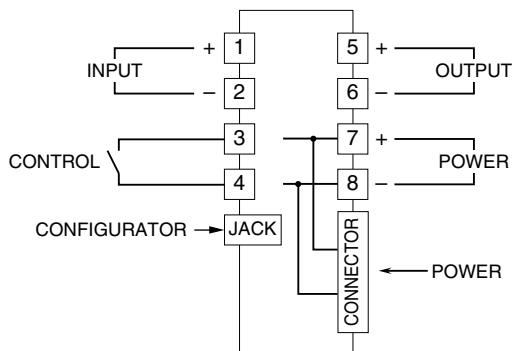

## ■ WIRING INSTRUCTIONS

- Applicable wire size
  - Solid: 0.2 to 2.5 mm<sup>2</sup> (0.55 to 1.75 dia.)
  - Stranded: 0.2 to 2.5 mm<sup>2</sup> (Tinning wire ends may cause contact failure and therefore is not recommended.)
  - Ferruled: 0.2 to 1.5 mm<sup>2</sup> (0.55 to 1.35 dia.)
- Expose wire conductors by 8 mm (0.31").

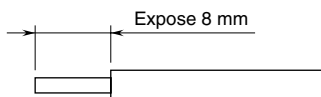

### • How to Connect Wires

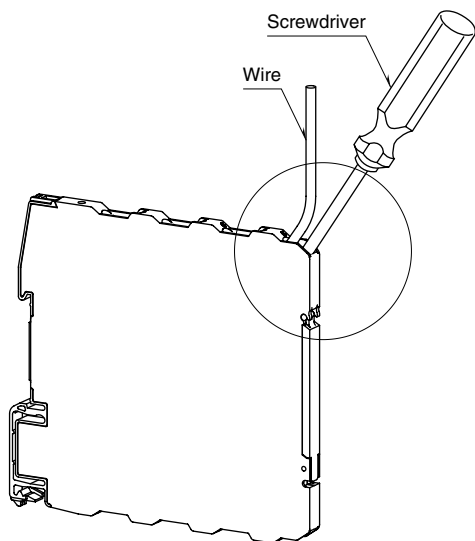

- 1) Insert a minus screwdriver into the wire entry opening, between the clamp and the housing, until its tip hits the bottom where it is firmly held.

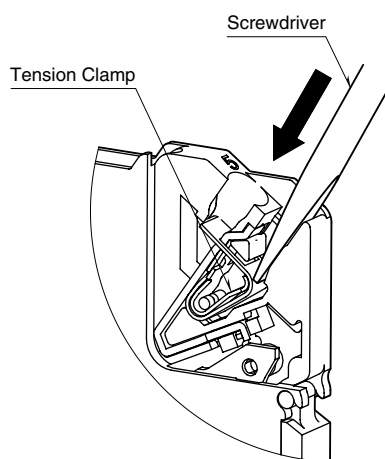

- 2) Insert a wire. Push the screwdriver toward the direction indicated with the arrow in the figure below to widen the opening if necessary.

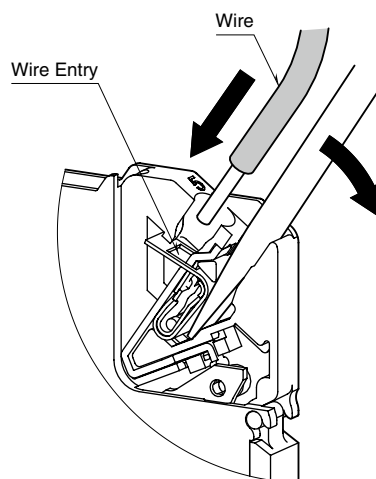

- 3) Confirm that the wire tip hits the bottom and pull out the screwdriver in holding it in position.

Confirm that the wire's insulation tube is not caught in the clamp.

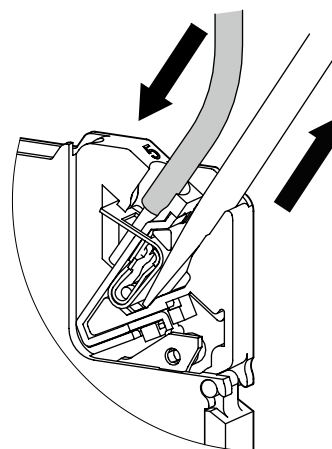

## EXTERNAL VIEWS

### FRONT VIEW (with the cover open)

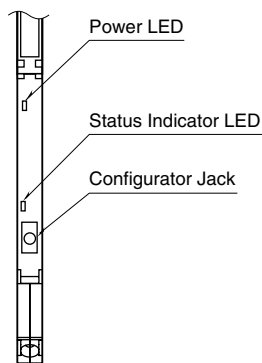

### SIDE VIEW

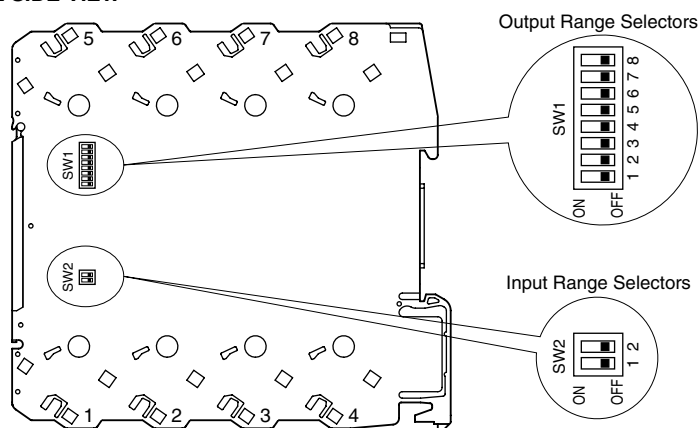

## INPUT/OUTPUT RANGING

The internal DIP switch setting is required to select input and output types before setting a precise range using PC Configurator Software (model: M6CFG).

For detailed information on the PC configuration, refer to the M6CFG users manual.

Table 1. DIP switch setting: Input type

Input Type	SW2-1
0 – 50 mA	ON
-1000 – +1000 mV	OFF
-10 – +10 V	OFF

Table 2. DIP switch setting: Output type

Output Type	SW1							
	1	2	3	4	5	6	7	8
0 – 20 mA*1	ON	ON	OFF	OFF	OFF	OFF	ON	OFF
-5 – +5 V	OFF	OFF	ON	OFF	ON	OFF	OFF	ON
-10 – +10 V	OFF	OFF	ON	OFF	OFF	ON	OFF	ON

\*1. For 0 – 1 mA range, set switches as in the table below.

Output Range	SW1							
	1	2	3	4	5	6	7	8
0 – 1 mA	OFF	OFF	ON	OFF	OFF	OFF	ON	OFF

## CHECKING

- 1) Terminal wiring: Check that all cables are correctly connected according to the connection diagram.
- 2) Confirm that the wire insulation tubes are not caught in the clamp.
- 3) Check DIP switch setting.
- 4) Power input voltage: Check voltage across the terminal 7 – 8 with a multimeter.
- 5) Input: Check that the input signal is within 0 – 100% of the full-scale.
- 6) Output: Check that the load resistance meets the described specifications.

## STATUS INDICATOR LED

The transmitter is provided with a status indicator LED which blinks in different patterns indicating various operating status.

The following figure indicates typical patterns.

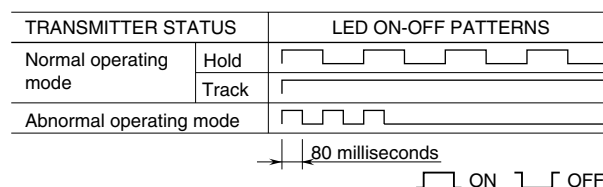

## MAINTENANCE

Regular calibration procedure is explained below:

### CALIBRATION

Warm up the unit for at least 10 minutes. Apply 0%, 25%, 50%, 75% and 100% input signal while the control input is TRACK. Check that the output signal for the respective input signal remains within accuracy described in the data sheet. When the output is out of tolerance, recalibrate the unit using the PC Configurator Software (model: M6CFG).

## LIGHTNING SURGE PROTECTION

M-System offers a series of lightning surge protector for protection against induced lightning surges. Please contact M-System to choose appropriate models.

---

## FUNCTIONS

### ■ CONTROL LOGIC

The control input can be chosen either hold at open or hold at close by using the PC Configurator Software. For detailed information on the PC Configuration, refer to the M6CFG users manual.

### ■ TRACK/HOLD

When the control input is TRACK, the output follows proportionally to the input.

When the control input turns to HOLD, the output at the point of command is held indefinitely.

### ■ PEAK HOLD

#### • Peak hold

When the control input is TRACK, the output follows proportionally to the input.

When the control input is HOLD, the output is held at the maximum input value. When the maximum input value is updated, the output changes to that value.

#### • Valley hold

When the control input is TRACK, the output follows proportionally to the input.

When the control input is HOLD, the output is held at the minimum input value. When the minimum input value is updated, the output changes to that value.

#### • Peak-to-peak hold

When the control input is TRACK, the output follows proportionally to the input.

When the control input is HOLD, the output is held at the maximum peak-to-peak input value (max. value – min. value). For example, the output is 20% if the maximum input value is 60% and the minimum input value is 40%. When the maximum peak-to-peak input value is updated, the output changes to that value.