

**BEFORE USE ....**

Thank you for choosing M-System. Before use, please check contents of the package you received as outlined below. If you have any problems or questions with the product, please contact M-System's Sales Office or representatives.

**■ PACKAGE INCLUDES:**

Power supply module ..... (1)

**■ MODEL NO.**

Confirm Model No. marking on the product to be exactly what you ordered.

**■ INSTRUCTION MANUAL**

This manual describes necessary points of caution when you use this product, including installation, connection and basic maintenance procedures.

**POINTS OF CAUTION**

**■ CONFORMITY WITH EU DIRECTIVES**

- The equipment must be mounted inside a panel.
- The actual installation environments such as panel configurations, connected devices, connected wires, may affect the protection level of this unit when it is integrated in a panel system. The user may have to review the CE requirements in regard to the whole system and employ additional protective measures to ensure the CE conformity.
- Install lightning surge protectors for those wires connected to remote locations.

**■ POWER INPUT RATING & OPERATIONAL RANGE**

- Locate the power input rating marked on the product and confirm its operational range as indicated below:  
24V DC rating: 22 – 27V, 2A

**■ GENERAL PRECAUTIONS**

- Before you remove the unit from its base or mount it, turn off the power supply for safety.

**■ ENVIRONMENT**

- Indoor use.
- When heavy dust or metal particles are present in the air, install the unit inside proper housing with sufficient ventilation.
- Do not install the unit where it is subjected to continuous vibration. Do not subject the unit to physical impact.
- Environmental temperature must be within -20 to +55°C (-4 to +131°F) with relative humidity within 30 to 90% RH in order to ensure adequate life span and operation.

**■ WIRING**

- Do not install cables close to noise sources (relay drive cable, high frequency line, etc.).
- Do not bind these cables together with those in which noises are present. Do not install them in the same duct.

**■ AND ....**

- The unit is designed to function as soon as power is supplied, however, a warm up for 10 minutes is required for satisfying complete performance described in the data sheet.

**COMPONENT IDENTIFICATION**

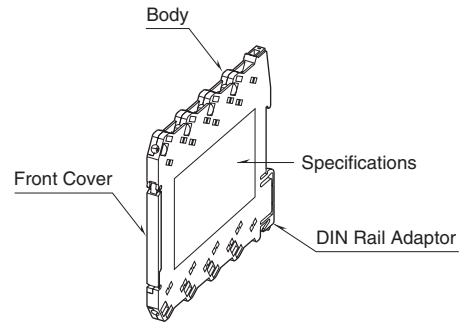

**■ FRONT VIEW (with the cover open)**

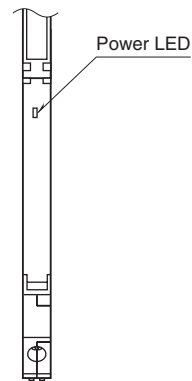

**INSTALLATION**

Installation Base (model: M6DBS) is required. Refer to the Installation Base instruction manual for the mounting procedure.

## TERMINAL CONNECTIONS

Connect the unit as in the diagram below or refer to the connection diagram on the side of the unit.

### EXTERNAL DIMENSIONS unit: mm (inch)

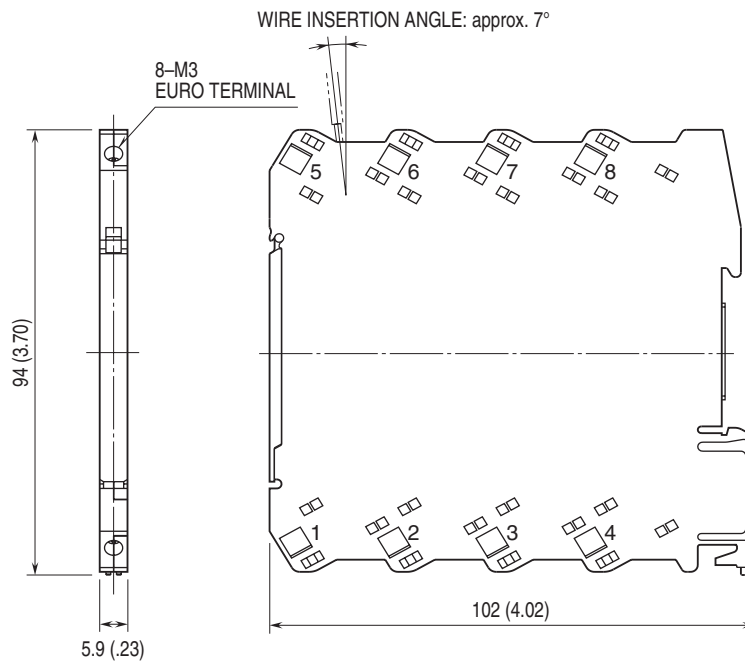

### CONNECTION DIAGRAM

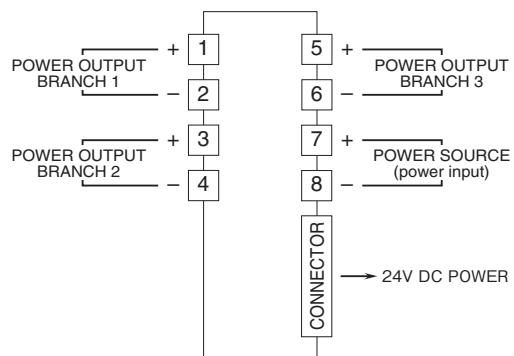

## ■ WIRING INSTRUCTIONS

- Applicable wire size

Solid: 0.2 to 2.5 mm<sup>2</sup> (0.55 to 1.75 dia.)

Stranded: 0.2 to 2.5 mm<sup>2</sup> (Tinning wire ends may cause contact failure and therefore is not recommended.)

Ferruled: 0.2 to 1.5 mm<sup>2</sup> (0.55 to 1.35 dia.)

- Expose wire conductors by 8 mm (0.31").

Wire exposure

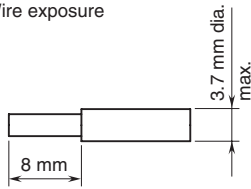

Recommended ferruled wire

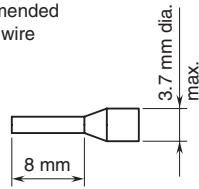

- How to Connect Wires

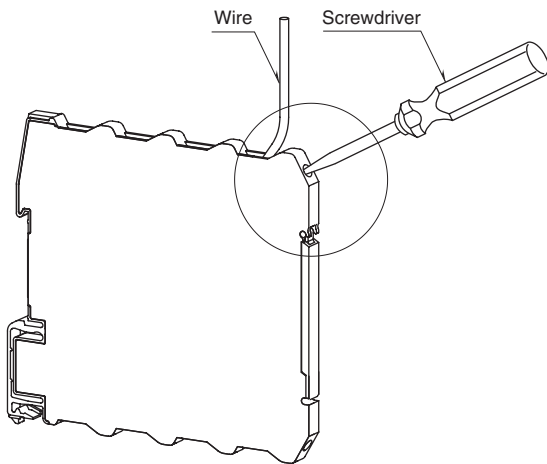

Insert a wire. Confirm that the wire tip hits the bottom and tighten the screw with a screwdriver.

Confirm that the wire's insulation tube is not caught in the terminal. (Torque: 0.3 N·m)

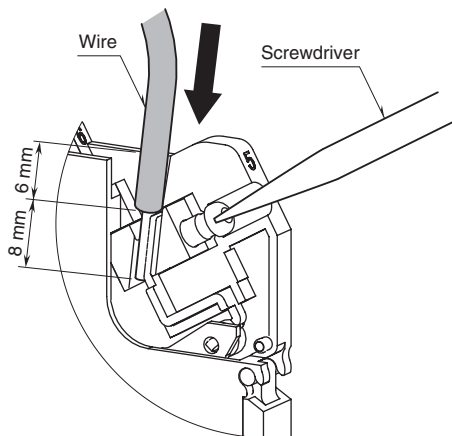

## CHECKING

- 1) Terminal wiring: Check that all cables are correctly connected according to the connection diagram.
- 2) Power input voltage: Check voltage across the terminal 7 – 8 with a multimeter.

## LIGHTNING SURGE PROTECTION

M-System offers a series of lightning surge protector for protection against induced lightning surges. Please contact M-System to choose appropriate models.