

SERVO-TOP II ELECTRONIC ACTUATOR
(linear type; failsafe function)MODEL **PSN1/PSN3****POINTS OF CAUTION****REGARDING FAILSAFE TYPE ACTUATOR (EMERGENCY USE)****■ INSTRUCTION MANUAL**

This manual describes necessary points of caution when you use the PSN1/PSN3 with the failsafe function.

Please also refer to the Instruction Manual for the PSN1/PSN3 (EM-4857 Rev.4 or later).

■ GENERAL PRECAUTIONS

- The PSN is shipped with the battery connector disconnected in order to prevent discharges. When you first use the PSN, connect the battery and charge it for more than three hours. Charge also after you replace the battery.
- There is no need to connect the battery connector for adjustments during installation of a valve. Adjustments can be conducted with a line power.
- Turn off the power supply for safety when wiring to the PSN.
- Disconnect the battery connector in order to prevent unnecessary discharges if you leave the PSN without power supplied for a long time.

■ ENVIRONMENT

- Inside building. If outside, keep away from direct sunlight.
- Ambient temperature: 0 to 55°C (32 to 131°F)
- Operating temperature for the battery
 - Charge: 0 to 55°C (32 to 131°F)
 - Storage: -20 to +55°C (-4 to +131°F), short term
 - 20 to +45°C (-4 to +104°F), long term
- Operating humidity: 30 to 85% RH (non-condensing)
- Vibration 2 G (19.6 m/s²) max.
- The actuator must be installed in a place where maintenance and inspection can be conducted. Observe at least 15 cm (5.9 in.) of open space at the top of its cover for maintenance and inspection.
- Keep away from hazardous atmosphere such like explosive or corrosive gases.

■ WIRING

- Do not install power supply and signal cables in the same duct in order to prevent malfunctions caused by induced noise. If they need to be installed closely, use shielded cables.

GENERAL DESCRIPTIONS

The PSN with Option /E has, in addition to the control valve actuator function, a failsafe function in case of no or abnormally low power input voltage.

In such cases, the actuator automatically goes to the preset position such as full-closed using the internal battery. A specific opening/closing speed for the safety shutdown operation can be also set.

When the power supply to the actuator is turned on, the PSN charges the battery first in rapid charge and then, detecting so-called 'minus delta V'* or after 180 minutes (approx.), moves to the trickle charge mode.

After the rapid charge cycle, the PSN's red BAT. STATUS LED turns on and the BAT. STATUS contact signal is output if the battery voltage is greater than approx. 22.5V. If the voltage level is lower, the LED blinks and the contact signal turns on and off synchronously with the LED.

* Minus Delta V: A characteristic bump of voltage increase curve at the battery terminals toward the end of rapid charge.

COMPONENT IDENTIFICATION

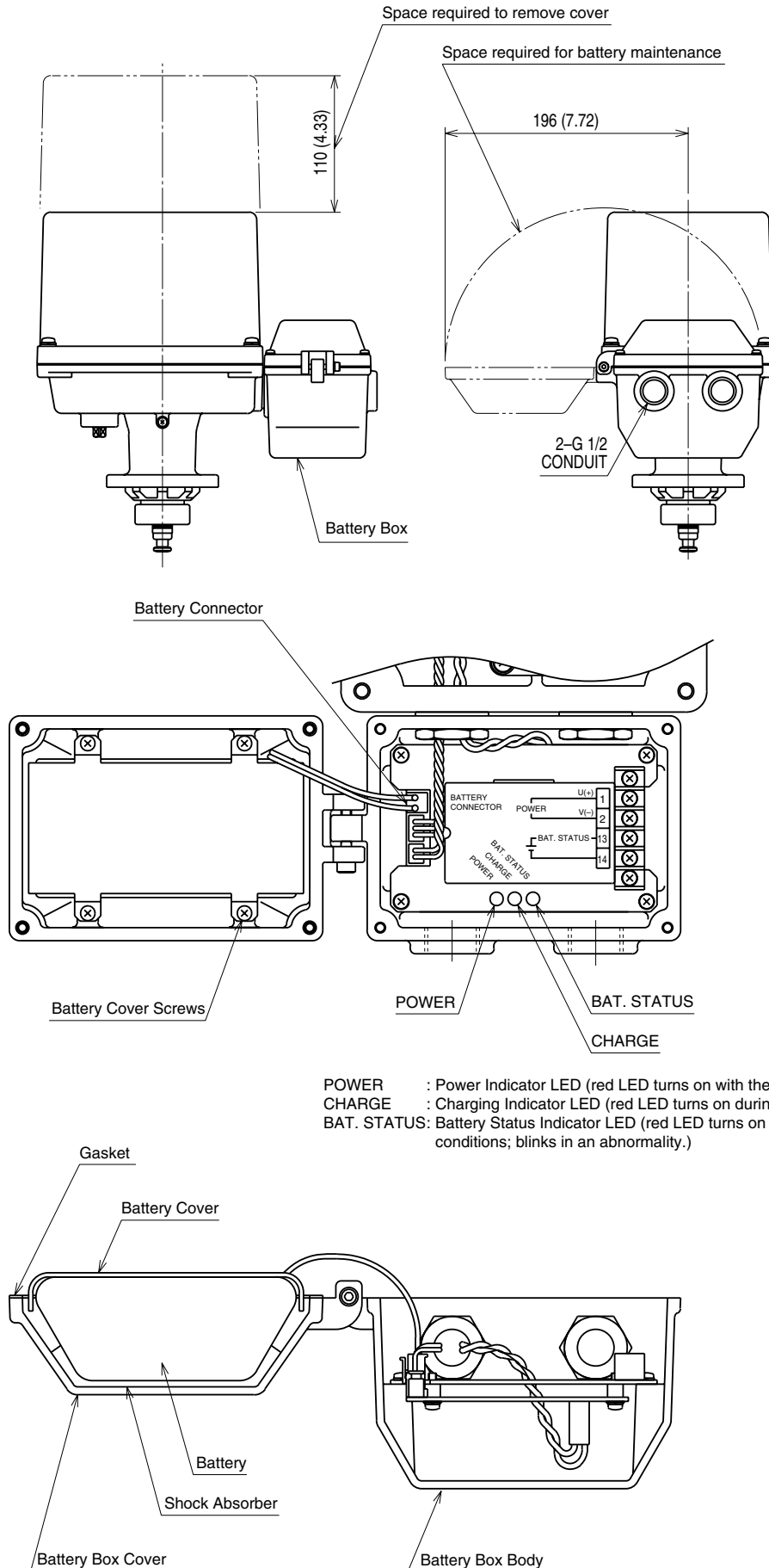

POWER : Power Indicator LED (red LED turns on with the power supplied)
 CHARGE : Charging Indicator LED (red LED turns on during charging)
 BAT. STATUS: Battery Status Indicator LED (red LED turns on in normal conditions; blinks in an abnormality.)

Figure 1. Component Identification

ELECTRICAL CONNECTIONS

Remove the covers of the PSN body and the battery box. Connect the signal input, position output and other signals to the body terminal block and the power input to the battery box terminal block according to Figure 2.

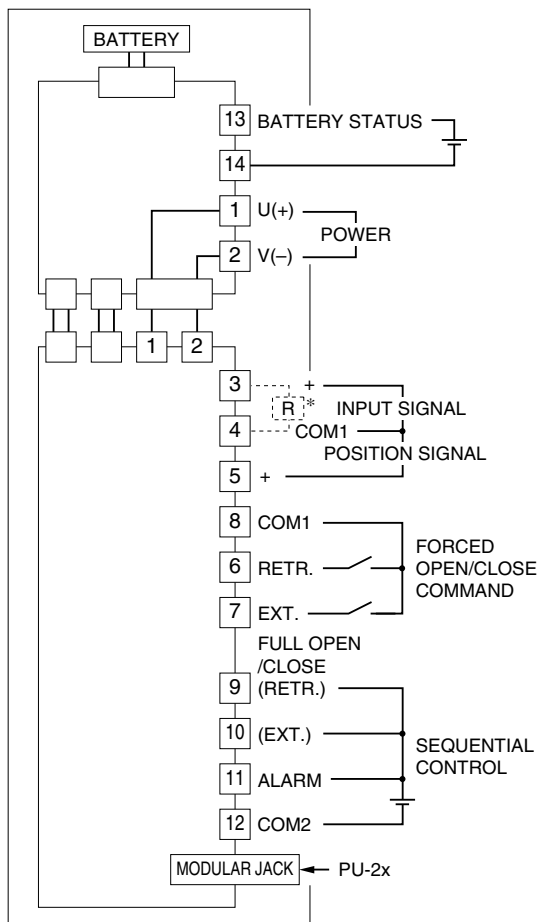

APPLICABLE SOLDERLESS TERMINAL

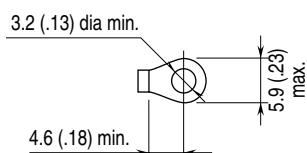

Figure 2. Connection Diagram & Applicable Solderless Terminal

PU-2x ADJUSTMENTS

Target position and opening/closing speed in the safety shutdown are field configurable.

Table 1 shows voltage levels determining 'Abnormally Low Voltage.'

Open the PSN body cover and connect the Programming Unit (model: PU-2x). Refer to the PSN1/PSN3 Instruction Manual (EM-4857 Rev.4 or later) for detailed procedures using the Programming Unit.

Table 1. Voltage levels determining abnormality

POWER INPUT RATING	ABNORMAL VOLTAGE
100 – 120V AC	65 – 80V AC or less
200 – 240V AC	180 – 160V AC or less
24V DC	18 – 19V DC or less

■ FAILSAFE TARGET POSITION (ITEM 23)

The output stem is automatically driven to a specific position within the full-stroke (0 to 100%).

Factory default: 0% (output stem fully extended)

■ FAILSAFE OPENING/CLOSING SPEED (ITEM 22)

Opening/closing speed can be set specifically for safety shutdown, independently from the speed in normal operations.

Factory default: 2.03 mm/s (PSN1), 2.05 mm/s (PSN3)

Note: Remind that the speed and the thrust relates inversely with each other: faster speed, smaller thrust. Choose an appropriate setting balancing the two.

HOW TO REPLACE THE BATTERY

- 1) Be sure to turn off the power supply.
- 2) Open the battery box cover.
- 3) Pull out the connector while holding down the latching. DO NOT pull at the cables.
- 4) Loosen the screws on top of the battery cover (4 places) and remove the cover. Remove the battery inside.
- 5) Replace a new battery (model: PSN-BAT) and put the cover on. Be careful that the wires are positioned in right direction and not caught at the edge of the cover.
- 6) Push in the connector back. Be sure that the latching is in right position.
- 7) Close the battery box cover. Be careful that the wires are not caught.

MAINTENANCE

For effective use and longer life of the PSN, regular checking appropriate for its operating conditions are recommended. For repair or parts replacement, contact us or representatives.

ITEM	CHECKING POINT	HOW TO PROCEED
Set the emergency shutdown target position to an end of the full stroke (ITEM 23). Drive the PSN stem to the other end and turn the power supply off, then check the following points:		
Functioning	The PSN is to operate over the entire stroke.	Check that the connector is firmly connected.
Speed setting	The PSN is to operate smoothly without making frequent start/stop movements.	Re-set the failsafe opening/closing speed (ITEM 22) to an appropriate value to get enough thrust.
After the above testing, return the PSN to the original setting and turn the power supply on.		
Battery charge	The BAT. STATUS indicator LED is to turn on within three (3) hours.	Refer to the table below and check the battery status.

BATTERY STATUS	LED STATUS WITH POWER SUPPLY ON	HOW TO PROCEED
Discharged	<p>POWER and CHARGE LED turn ON and then BAT. STATUS turns ON. Rapid charge is complete within approx. 180 minutes (T) and CHARGE LED turns OFF.</p>	Normal
Full charge	<p>All three (3) LEDs turn ON and only CHARGE LED turns OFF after a while.</p>	Normal
No connection	<p>POWER LED turns ON and BAT. STATUS LED blinks.</p> <p>..... Blinking</p>	Check that the battery connector is firmly connected; check also for wire breakdown.
End of life	<p>POWER and CHARGE LED turn ON. CHARGE LED turns OFF after approx. 180 minutes (T) and BAT. STATUS LED blinks.</p>	Replace with a new battery.

■ BATTERY

The NiCad battery is designed for long life and does not need any special care. However, please check periodically for a leak and rust on and around the battery.

Battery's life is affected by many factors in complex way and can not be determined easily. To give an indication, we recommend a new battery replacement every three (3) years.

■ TEST OPERATION

If the actuator is to be stopped for a long time, run a test operation regularly (every three months, for example) to check proper functions.

TROUBLESHOOTING

TROUBLE	POWER LED	CHG LED	BAT LED	POSSIBLE CAUSE	HOW TO PROCEED
Not functioning	OFF	----	----	Wiring error	Check the connector and other connecting sections.
				Abnormal power supply voltage	Check the power source.
				Fuse melted	Replace the fuse.
	ON	----	Blink	Battery connector is not secured.	Check that the battery connector is firmly connected; check also for wire breakdown.
				End of battery life	Replace it with a new one.
	ON	ON	OFF	Rapid charging	Wait until the rapid charge is complete.
	ON	OFF	ON	Control PCB is damaged.	Repair

---- Any state.

LIGHTNING SURGE PROTECTION

We offer a series of lightning surge protectors for protection against induced lightning surges. Please contact us to choose appropriate models.