

**Space-saving Dual Output Signal Conditioners
Mini-MW Series**

THERMOCOUPLE TRANSMITTER

(PC programmable)

Functions & Features

- Accepts direct input from a thermocouple and provides a linearized process signal
- PC programmable
- Wide selection of thermocouples
- User's temperature table can be used
- High-density mounting

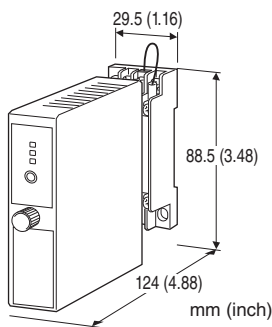

MODEL: W2XT-[1][2][3]-[4][5]

ORDERING INFORMATION

- Code number: W2XT-[1][2][3]-[4][5]
- Specify a code from below for each of [1] through [5].
(e.g. W2XT-2Z1V3-M2/N/Q)
- Temperature range (e.g. 0 - 800°C)
- Output 1 range (e.g. 4 - 20 mA DC)
- Output 2 range (e.g. 1 - 5 V DC)
- Specify the specification for option code /Q
(e.g. /C01/S01/SET)

Note: When the user requires a current and a voltage output, specify the current to be the Output 1 which allows a greater load.

[1] INPUT THERMOCOUPLE

- 1: (PR)
- 2: K (CA)
- 3: E (CRC)
- 4: J (IC)
- 5: T (CC)
- 6: B (RH)
- 7: R
- 8: S
- 9: C (WRe 5-26)

- N: N
- U: U
- L: L
- P: Platinel II
- 0: Specify
(Configurator software is used to change the input type and precise range.)

[2] OUTPUT 1

Current

Z1: Range 0 - 20 mA DC

Voltage

V2: Range -10 - +10 V DC

V3: Range -5 - +5 V DC

(Configurator software is used to change output over the described range of the selected suffix code.

For changing between suffix codes, set the Output Range Selector on the side of unit before software adjustment.)

[3] OUTPUT 2

Same range availability as Output 1

Y: None

(Configurator software is used to change output over the described range of the selected suffix code.

For changing between suffix codes, set the Output Range Selector on the side of unit before software adjustment.)

[4] POWER INPUT

AC Power

M2: 100 - 240 V AC (Operational voltage range 85 - 264 V, 47 - 66 Hz)

DC Power

R: 24 V DC

(Operational voltage range 24 V ±10 %, ripple 10 %p-p max.)

[5] OPTIONS (multiple selections)

Standards & Approvals (must be specified)

/N: Without CE

Other Options

blank: none

/Q: Option other than the above (specify the specification)

SPECIFICATIONS OF OPTION: Q (multiple selections)

COATING (For the detail, refer to M-System's web site.)

/C01: Silicone coating

/C02: Polyurethane coating

/C03: Rubber coating

TERMINAL SCREW MATERIAL

/S01: Stainless steel

EX-FACTORY SETTING

/SET: Preset according to the Ordering Information Sheet
(No. ESU-5508)

RELATED PRODUCTS

- PC configurator software (model: W2CFG)

Downloadable at M-System's web site.

A dedicated cable is required to connect the module to the PC. Please refer to the internet software download site or the users manual for the PC configurator for applicable cable types.

GENERAL SPECIFICATIONS

Construction: Plug-in

Connection: M3 screw terminals (torque 0.8 N·m)

Screw terminal: Chromated steel (standard) or stainless steel

Housing material: Flame-resistant resin (black)

Isolation: Input to output 1 to output 2 to power

Overrange output: -15 to +115 %

(Negative current output is not available.)

Zero adjustment: -5 to +5 % (PC programming)

Span adjustment: 95 to 105 % (PC programming)

Burnout: Upscale standard; downscale, specific value output or no burnout optional by programming

Linearization: Standard

Cold junction compensation: CJC sensor attached to the input terminals

Status indicator LED: Tri-color (green/amber/red) LED;

Blinking patterns indicate operation status of the transmitter.

Programming: Downloaded from PC; input type and range, output type and range, zero and span, burnout type, user's linearization table, etc.

For detailed information, refer to the users manual for the PC configurator.

Configurator connection: 2.5 dia. miniature jack; RS-232-C level

INPUT SPECIFICATIONS

Input resistance: 1 M Ω min.

Burnout sensing: $\leq 4 \mu\text{A}$

If not specified, the input range is shown below.

1 PR: 0-1600°C

2 K: 0-1000°C

3 E: 0-500°C

4 J: 0-500°C

5 T: 0-300°C

6 B: 500-1600°C

7 R: 500-1600°C

8 S: 0-1600°C

9 C (WRe 5-26): 0-2000°C

N N: 0-1000°C

U U: 0-300°C

L L: 0-500°C

P Platinel II: 0-1200°C

OUTPUT SPECIFICATIONS

■ DC Current

Operational range: 0 - 23 mA DC

Minimum span: 1 mA

Offset: Lower range can be any specific value within the output range provided that the minimum span is maintained.

Load resistance: Output drive 12 V max. for Output 1; 7 V max. for Output 2

(e.g. 4 - 20 mA: 600 Ω [12 V \div 20 mA])

If not specified, the output range is 4 - 20 mA DC.

■ DC Voltage

Code V2 (wide spans)

Operational range: -11.5 - +11.5 V DC

Minimum span: 1 V

Code V3 (narrow spans)

Operational range: -6 - +6 V DC

Minimum span: 0.5 V

Offset: Lower range can be any specific value within the output range provided that the minimum span is maintained.

Load resistance: Output drive 1 mA max.

(e.g. 1 - 5 V: 5000 Ω [5 V \div 1 mA])

If not specified, the output range is shown below.

V2: 0 - 10 V DC

V3: 1 - 5 V DC

INSTALLATION

Power Consumption

• AC:

Approx. 5 VA at 100 V

Approx. 6 VA at 200 V

Approx. 7 VA at 240 V

• DC: Approx. 3 W

Operating temperature: -5 to +55°C (23 to 131°F)

Operating humidity: 30 to 90 %RH (non-condensing)

Mounting: Surface or DIN rail

Weight: 150 g (0.33 lb)

PERFORMANCE in percentage of span

Overall accuracy: Input accuracy + output accuracy

• **Input accuracy:** Accuracy (Table 1) + Cold Junction Compensation Error 3°C (5.4°F)

• **Output accuracy:** Max. Output Range \div Span $\times \pm 0.04\%$

Cold junction compensation error:

$\pm 3^\circ\text{C}$ at 25 $\pm 10^\circ\text{C}$

±5.4°F at 77 ±18°F

Temp. coefficient: ±0.015 %/°C (±0.008 %/°F) of max. span

Response time: ≤ 1 sec. (0 - 90 %)

Burnout response: ≤ 10 sec.

Line voltage effect: ±0.1 % over voltage range

Insulation resistance: ≥ 100 MΩ with 500 V DC

Dielectric strength: 2000 V AC @1 minute (input to output
1 to output 2 to power to ground)

CALCULATION EXAMPLES OF OVERALL ACCURACY

[Example] K thermocouple, 0 - 1000°C, 4 - 20 mA DC
output

Absolute value accuracy (Table 1): 0.25°C

CJC error (3°C) added: 3.25°C

• Input accuracy = 3.25°C ÷ 1000°C × 100 = 0.325 %

Output span: 16 mA (20 - 4)

• Output accuracy = 20 mA ÷ 16 mA × 0.04 = 0.05 %

Overall accuracy including CJC error = 0.325 + 0.05 =
±0.38 % of span

Table 1.

THERMO- COUPLE	°C			
	MIN. SPAN	MAXIMUM RANGE	ACCURACY	CONFORMANCE RANGE
(PR)	20	0 to 1760	±1.00	0 to 1760
K (CA)	20	-270 to +1370	±0.25	-150 to +1370
E (CRC)	20	-270 to +1000	±0.20	-170 to +1000
J (IC)	20	-210 to +1200	±0.25	-180 to +1200
T (CC)	20	-270 to +400	±0.25	-170 to +400
B (RH)	20	100 to 1820	±0.75	400 to 1760
R	20	-50 to +1760	±0.50	200 to 1760
S	20	-50 to +1760	±0.50	0 to 1760
C (WRe 5-26)	20	0 to 2315	±0.80	0 to 2315
N	20	-270 to +1300	±0.30	-130 to +1300
U	20	-200 to +600	±0.20	-200 to +600
L	20	-200 to +900	±0.25	-200 to +900
P (Platinel II)	20	0 to 1395	±0.25	0 to 1395
THERMO- COUPLE	°F			
	MIN. SPAN	MAXIMUM RANGE	ACCURACY	CONFORMANCE RANGE
(PR)	36	32 to 3200	±1.80	32 to 3200
K (CA)	36	-454 to +2498	±0.45	-238 to +2498
E (CRC)	36	-454 to +1832	±0.36	-274 to +1832
J (IC)	36	-346 to +2192	±0.45	-292 to +2192
T (CC)	36	-454 to +752	±0.45	-274 to +752
B (RH)	36	212 to 3308	±1.35	752 to 3200
R	36	-58 to +3200	±0.90	392 to 3200
S	36	-58 to +3200	±0.90	32 to 3200
C (WRe 5-26)	36	32 to 4199	±1.44	32 to 4199
N	36	-454 to +2372	±0.54	-202 to +2372
U	36	-328 to +1112	±0.36	-328 to +1112
L	36	-328 to +1652	±0.45	-328 to +1652
P (Platinel II)	36	32 to 2543	±0.45	32 to 2543

EXTERNAL VIEW

FRONT VIEW

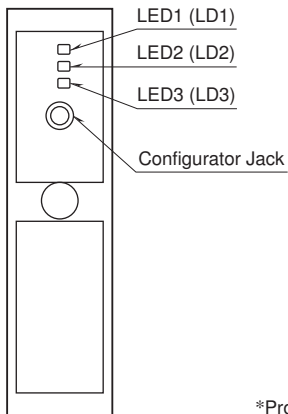

SIDE VIEW

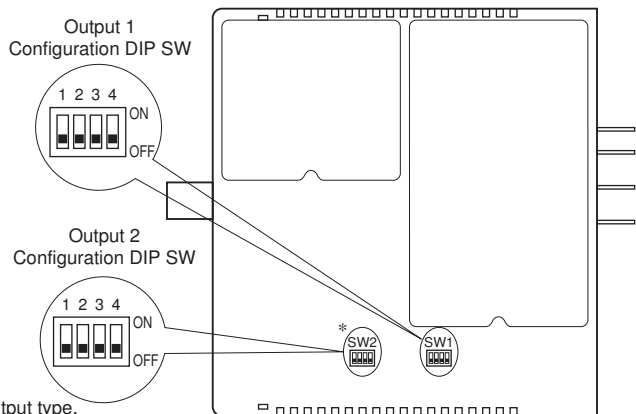

*Provided only for two-output type.

Refer to the instruction manual for detailed procedures.

EXTERNAL DIMENSIONS unit: mm (inch)

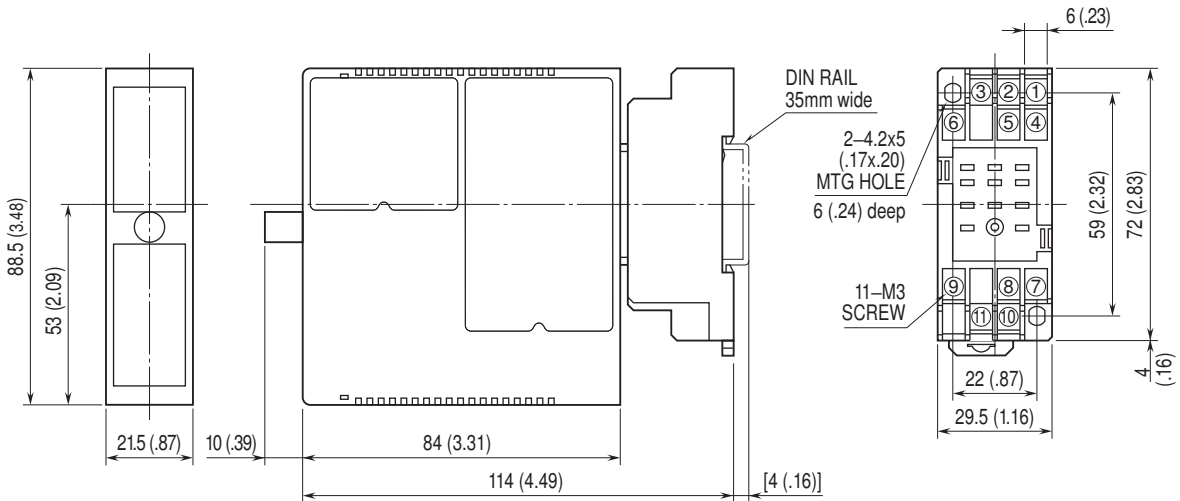

• When mounting, no extra space is needed between units.

TERMINAL ASSIGNMENTS

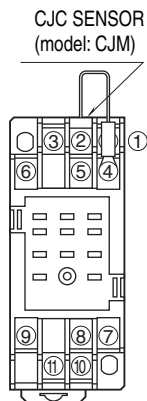

SCHEMATIC CIRCUITRY & CONNECTION DIAGRAM

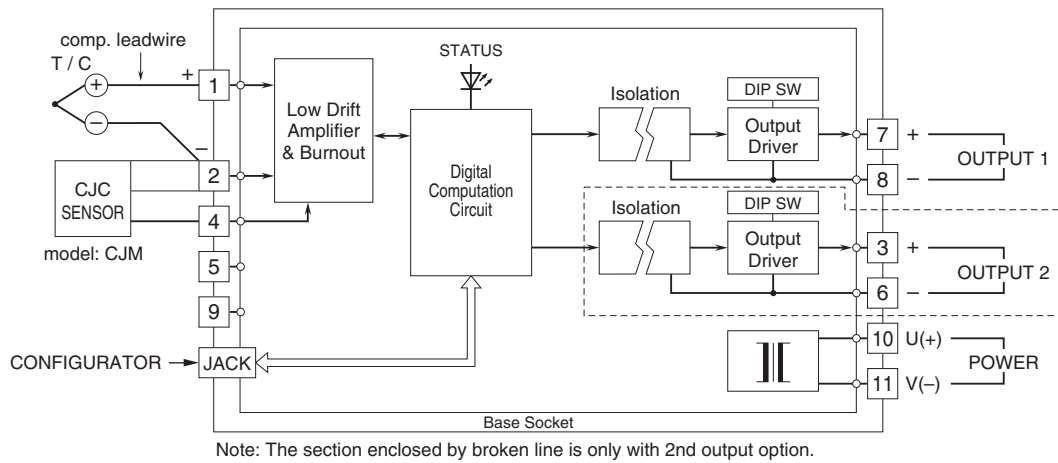

Specifications are subject to change without notice.