

Space-saving Dual Output Signal Conditioners Mini-MW Series

CURRENT LOOP SUPPLY

Functions & Features

- Powers a 4 – 20 mA DC current loop
- Shortcircuit protection
- Applicable to smart transmitters

Typical Applications

- Various 2-wire transmitters

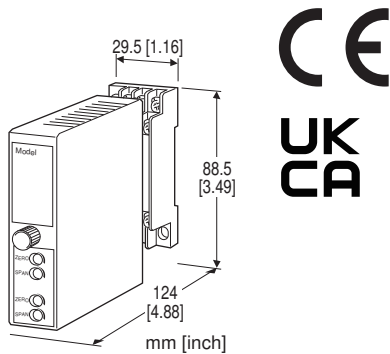

MODEL: W2DY-24[1][2]-[3][4]

ORDERING INFORMATION

- Code number: W2DY-24[1][2]-[3][4]
- Specify a code from below for each of [1] through [4].
(e.g. W2DY-24A6-R/CE/Q)
- Special output ranges (For codes Z & 0)
- Specify the specification for option code /Q
(e.g. /C01/V01)

Note: When the user requires a current and a voltage output, specify the current to be the Output 1 which allows a greater load.

SUPPLY OUTPUT

24: 24 V DC

INPUT

Current

4 – 20 mA DC

[1] OUTPUT 1

Current

- A: 4 – 20 mA DC (Load resistance 750 Ω max.)
- B: 2 – 10 mA DC (Load resistance 1500 Ω max.)
- C: 1 – 5 mA DC (Load resistance 3000 Ω max.)
- D: 0 – 20 mA DC (Load resistance 750 Ω max.)

- E: 0 – 16 mA DC (Load resistance 900 Ω max.)
- F: 0 – 10 mA DC (Load resistance 1500 Ω max.)
- G: 0 – 1 mA DC (Load resistance 15 kΩ max.)
- Z: Specify current (See OUTPUT SPECIFICATIONS)

Voltage

- 1: 0 – 10 mV DC (Load resistance 10 kΩ min.)
- 2: 0 – 100 mV DC (Load resistance 100 kΩ min.)
- 3: 0 – 1 V DC (Load resistance 1000 Ω min.)
- 4: 0 – 10 V DC (Load resistance 10 kΩ min.)
- 5: 0 – 5 V DC (Load resistance 5000 Ω min.)
- 6: 1 – 5 V DC (Load resistance 5000 Ω min.)
- 0: Specify voltage (See OUTPUT SPECIFICATIONS)

[2] OUTPUT 2

Y: None

Current

- A: 4 – 20 mA DC (Load resistance 350 Ω max.)
- B: 2 – 10 mA DC (Load resistance 700 Ω max.)
- C: 1 – 5 mA DC (Load resistance 1400 Ω max.)
- D: 0 – 20 mA DC (Load resistance 350 Ω max.)
- E: 0 – 16 mA DC (Load resistance 430 Ω max.)
- F: 0 – 10 mA DC (Load resistance 700 Ω max.)
- G: 0 – 1 mA DC (Load resistance 7000 Ω max.)
- Z: Specify current (See OUTPUT SPECIFICATIONS)

Voltage

Same range availability as Output 1

[3] POWER INPUT

AC Power

M2: 100 – 240V AC (Operational voltage range 85 – 264 V, 47 – 66 Hz)
(Select '/N' for 'Standards & Approvals' code.)

DC Power

R: 24 V DC
(Operational voltage range 24 V ±10 %, ripple 10 %p-p max.)
R2: 11 – 27 V DC
(Operational voltage range 11 – 27 V, ripple 10 %p-p max.)
(Select '/N' for 'Standards & Approvals' code.)
P: 110 V DC
(Operational voltage range 85 – 150 V, ripple 10 %p-p max.)
(Select '/N' for 'Standards & Approvals' code.)

[4] OPTIONS (multiple selections)

Standards & Approvals (must be specified)

- /N: Without CE or UKCA
- /CE: CE marking
- /UK: CE, UKCA marking

Other Options

- blank: none
- /Q: Option other than the above (specify the specification)

SPECIFICATIONS OF OPTION: Q (multiple selections)

COATING (For the detail, refer to M-System's web site.)

/C01: Silicone coating

/C02: Polyurethane coating

/C03: Rubber coating

ADJUSTMENT

/V01: Multi-turn fine adjustment

TERMINAL SCREW MATERIAL

/S01: Stainless steel

GENERAL SPECIFICATIONS

Construction: Plug-in

Connection: M3 screw terminals (torque 0.8 N·m)

Screw terminal: Chromated steel (standard) or stainless steel

Housing material: Flame-resistant resin (black)

Isolation: Input to output 1 to output 2 to power

Overrange output: Approx. -10 to +120 % at 1 - 5 V

Zero adjustment: -5 to +5 % (front)

Span adjustment: 95 to 105 % (front)

Adjustable individually for each output 1 and output 2.

SUPPLY OUTPUT

Output voltage: 24 - 28 V DC with no load

Current rating: ≤ 22 mA DC

• **Shortcircuit Protection**

Current limited: 30 mA max.

Protected time duration: No limit

INPUT SPECIFICATIONS

■ **DC Current:** Input resistors incorporated

Approx. 300 Ω (50 Ω as receiving resistor, 250 Ω across the monitor terminals)

OUTPUT SPECIFICATIONS

■ **DC Current:** 0 - 20 mA DC

Minimum span: 1 mA

Offset: Max. 1.5 times span

Load resistance: Output drive 15 V max. for Output 1;
7 V max. for Output 2

■ **DC Voltage:** 0 - 12 V DC (up to 10 V for Output 2)

Minimum span: 5 mV

Offset: ≤ 1.5 times span

Load resistance: Output drive 1 mA max.; at ≥0.5 V

INSTALLATION

Power Consumption

• **AC:**

Approx. 5 VA at 100 V

Approx. 6 VA at 200 V

Approx. 7 VA at 240 V

• **DC:** Approx. 3 W

Operating temperature: -5 to +55°C (23 to 131°F)

Operating humidity: 30 to 90 %RH (non-condensing)

Mounting: Surface or DIN rail

Weight: 200 g (0.44 lb)

PERFORMANCE in percentage of span

Accuracy: ±0.1 %

Temp. coefficient: ±0.015 %/°C (±0.008 %/°F)

Response time: ≤ 0.5 sec. (0 - 90 %)

Line voltage effect

Supply output: ±3 % over voltage range

Output signal: ±0.1 % over voltage range

Insulation resistance: ≥ 100 MΩ with 500 V DC

Dielectric strength: 2000 V AC @1 minute (input to output 1 to output 2 to power to ground)

STANDARDS & APPROVALS

EU conformity:

EMC Directive

EMI EN 61000-6-4

EMS EN 61000-6-2

RoHS Directive

UK conformity (UKCA):

The UK legislations and designated standards are equivalent to the applicable EU directives.

(Refer to M-System's website for more information about the legislations and designated standards.)

EXTERNAL DIMENSIONS & TERMINAL ASSIGNMENTS unit: mm [inch]

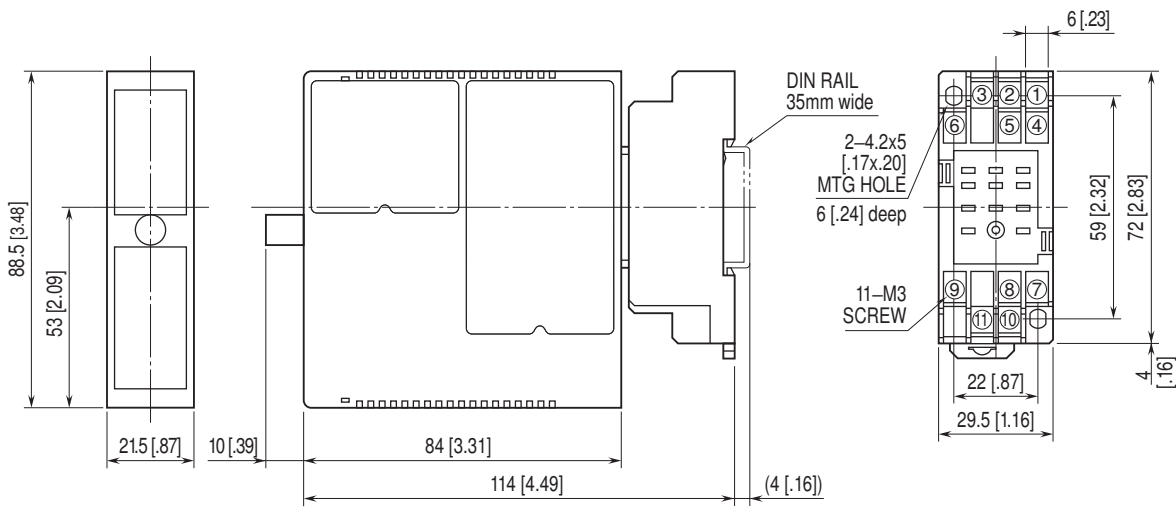

• When mounting, no extra space is needed between units.

SCHEMATIC CIRCUITRY & CONNECTION DIAGRAM

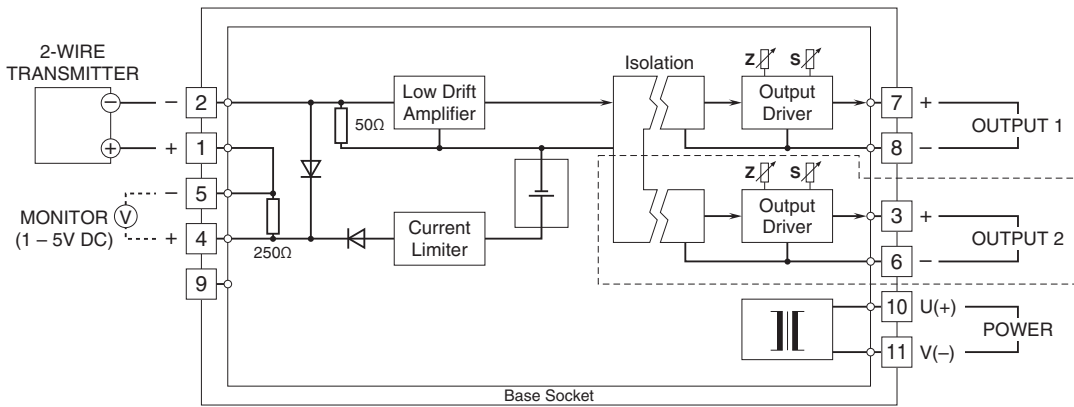

Note: The section enclosed by broken line is only with 2nd output option.



Specifications are subject to change without notice.