

POTENTIOMETER TRANSMITTER
(PC programmable)

MODEL **W2XM**

BEFORE USE

Thank you for choosing M-System. Before use, please check contents of the package you received as outlined below. If you have any problems or questions with the product, please contact M-System's Sales Office or representatives.

■ PACKAGE INCLUDES:

Signal conditioner (body + base socket).....(1)

■ MODEL NO.

Confirm Model No. marking on the product to be exactly what you ordered.

■ INSTRUCTION MANUAL

This manual describes necessary points of caution when you use this product, including installation, connection and basic maintenance procedures.

The unit is programmable using the PC Configurator Software. For detailed information on the PC configuration, refer to the W2CFG users manual. The W2CFG PC Configurator Software is downloadable at M-System's web site: <http://www.m-system.co.jp>.

POINTS OF CAUTION

■ POWER INPUT RATING & OPERATIONAL RANGE

- Locate the power input rating marked on the product and confirm its operational range as indicated below:
 100 – 240V AC rating: 85 – 264V, 47 – 66 Hz, approx. 5 – 7VA
 24V DC rating: 24V ±10%, approx. 3W
 11 – 27V DC rating: 11 – 27V, approx. 3W
 110V DC rating: 85 – 150V, approx. 3W

■ GENERAL PRECAUTIONS

- To protect very delicate components contained inside the unit against damage from static electricity, wear a grounded wrist strap when handling them. If you do not have one, touch both of your hands to a safely grounded object or to a metal object.
- Ensure that the power supply and input signal are switched off before you plug in or remove the unit.
- Before you remove the unit from its base socket or mount it, turn off the power supply and input signal for safety.

■ ENVIRONMENT

- Indoor use.
- When heavy dust or metal particles are present in the air, install the unit inside proper housing with sufficient ventilation.
- Do not install the unit where it is subjected to continuous vibration. Do not subject the unit to physical impact.
- Environmental temperature must be within -5 to +55°C (23 to 131°F) with relative humidity within 30 to 90% RH in order to ensure adequate life span and operation.
- Be sure that the ventilation slits are not covered with cables, etc.

■ WIRING

- Do not install cables close to noise sources (relay drive cable, high frequency line, etc.).
- Do not bind these cables together with those in which noises are present. Do not install them in the same duct.

■ AND

- The unit is designed to function as soon as power is supplied, however, a warm up for 10 minutes is required for satisfying complete performance described in the data sheet.
- With voltage output, do not leave the output terminals shortcircuited for an extended time period. The unit is designed to endure it without breakdown, however, it may shorten appropriate life duration.

COMPONENT IDENTIFICATION

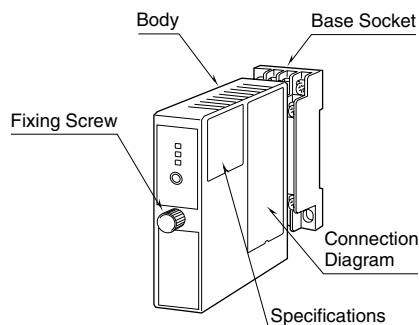

INSTALLATION

Loosen the fixing screw at the front of the unit in order to separate the body from the base socket.

■ DIN RAIL MOUNTING

Set the base socket so that its DIN rail adaptor is at the bottom. Position the upper hook at the rear side of base socket on the DIN rail and push in the lower. When removing the socket, push down the DIN rail adaptor utilizing a minus screwdriver and pull.

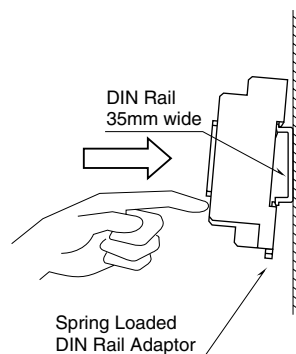

■ WALL MOUNTING

Refer to "EXTERNAL DIMENSIONS."

TERMINAL CONNECTIONS

Connect the unit as in the diagram below or refer to the connection diagram on the side of the unit.

EXTERNAL DIMENSIONS unit: mm (inch)

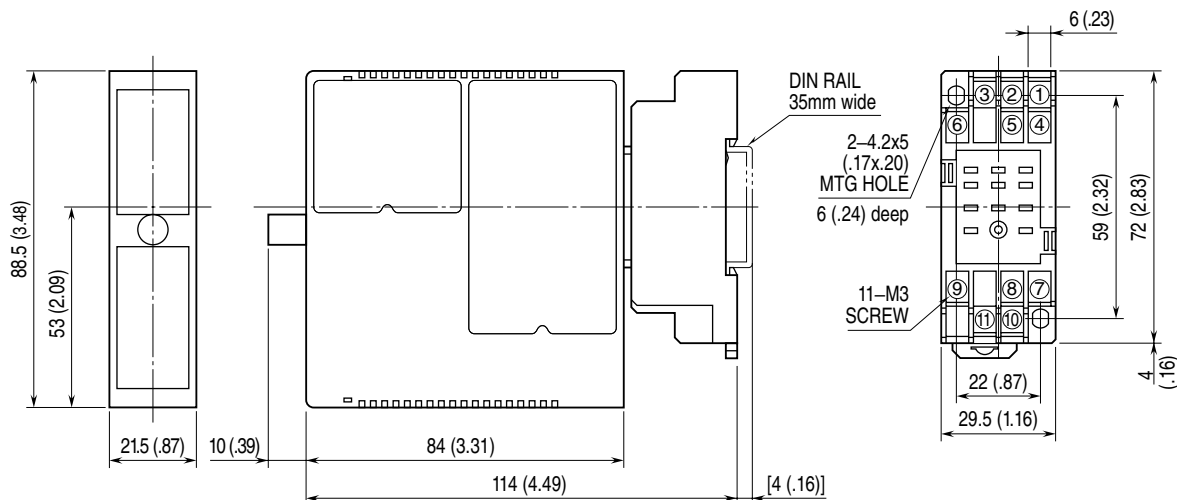

• When mounting, no extra space is needed between units.

CONNECTION DIAGRAM

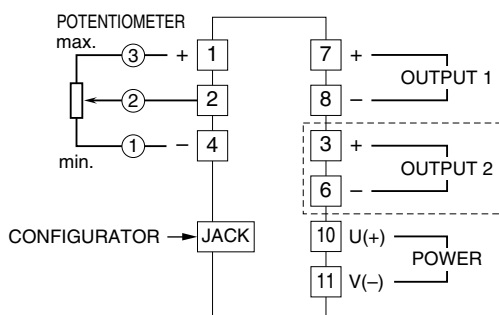

The section enclosed by broken line is only with 2nd output option.

WIRING INSTRUCTIONS

SCREW TERMINAL

Torque: 0.8 N·m

SOLDERLESS TERMINAL

Refer to the drawing below for recommended ring tongue terminal size. Spade tongue type is also applicable. Applicable wire size: 0.25 to 1.65 mm² (AWG 22 to 16) Recommended manufacturer: Japan Solderless Terminal MFG.Co.Ltd, Nichifu Co.,Ltd

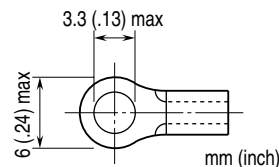

EXTERNAL VIEWS

FRONT VIEW

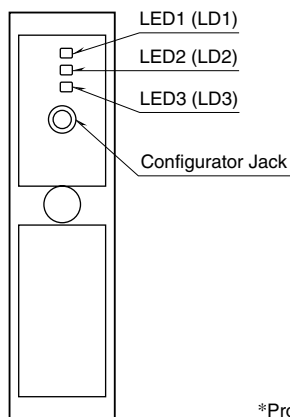

SIDE VIEW

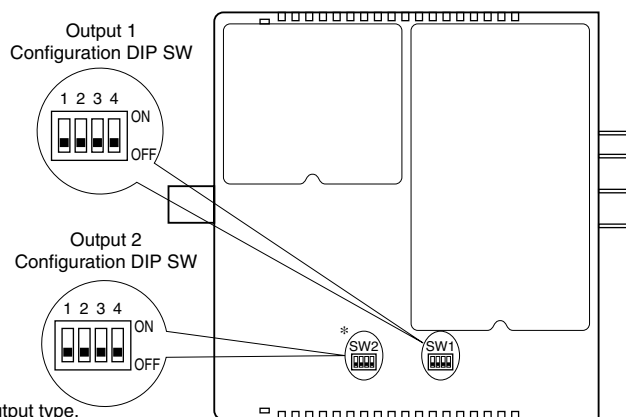

*Provided only for two-output type.

OUTPUT RANGING

The internal DIP switch setting is required to select output types before setting a precise output range using PC Configurator Software (model: W2CFG).

For detailed information on the PC configuration, refer to the W2CFG users manual.

Table 1. DIP switch setting: Output 1 type

OUTPUT 1 TYPE	SW1-1	SW1-2	SW1-3	SW1-4
0 – 20 mA DC	OFF	OFF	ON	OFF
-10 – +10 V DC	OFF	ON	OFF	ON
-5 – +5 V DC	ON	OFF	OFF	ON

Table 2. DIP switch setting: Output 2 type

OUTPUT 2 TYPE	SW2-1	SW2-2	SW2-3	SW2-4
0 – 20 mA DC	OFF	OFF	ON	OFF
-10 – +10 V DC	OFF	ON	OFF	ON
-5 – +5 V DC	ON	OFF	OFF	ON

CHECKING

- 1) Terminal wiring: Check that all cables are correctly connected according to the connection diagram.
- 2) Check DIP switch setting.
- 3) Power input voltage: Check voltage across the terminal 10 – 11 with a multimeter.
- 4) Input: Check that the input signal is within 0 – 100% of the full-scale.





















If the potentiometer wires are broken, the output goes over 100% (below 0% with downscale) due to burnout function. Confirm the status indicator LED pattern and check leadwires in such a case.







- 5) Output: Check that the load resistance meets the described specifications.
- 6) LED: Confirm that the LEDs indicate the normal operating mode.

STATUS INDICATOR LED

Combinations of the three front LEDs (LD1, LD2, LD3) indicate the transmitter's operating status by different blinking patterns.

Examples are shown below.

NORMAL OPERATION (RUN) MODE			
LD1 	PC Configuration RUN Mode The transmitter is configured via PC and is in normal operating conditions.		
LD2 			
LD3 			
ERROR MODE			
LD1 	Parameter Error Error occurred when reading parameters from the internal memory.	LD1 	Overrange Input The input is below -15% or above 115%.
LD2 		LD2 	
LD3 		LD3 	
LD1 	AD Conversion Error Internal AD conversion error. *1. LD1 may be one of the   	LD1 	Output Limit The output is at the upper or the lower limit.
LD2 		LD2 	
LD3 		LD3 	
		LD1 	Burnout
		LD2 	
		LD3 	

-  Amber LED  OFF
 Green LED  ON
 Red LED  Blink

MAINTENANCE

Regular calibration procedure is explained below:

■ CALIBRATION

Warm up the unit for at least 10 minutes. Apply 0%, 25%, 50%, 75% and 100% input signal. Check that the output signal for the respective input signal remains within accuracy described in the data sheet. When the output is out of tolerance, recalibrate the unit using the PC Configurator Software (model: W2CFG).

LIGHTNING SURGE PROTECTION

M-System offers a series of lightning surge protector for protection against induced lightning surges. Please contact M-System to choose appropriate models.