

Dual Output Plug-in Signal Conditioners W-UNIT

PT TRANSMITTER

Functions & Features

- Converting an alternating voltage from a potential (voltage) transformer into two standard process signals
- Minimum ripple
- True RMS sensing
- Isolation up to 2000 V AC
- LCD meter
- Highdensity mounting

Typical Applications

- Centralized monitoring and control of power line and power supply voltage measured at switch boards
- Monitoring abnormal voltage drops for detecting overload

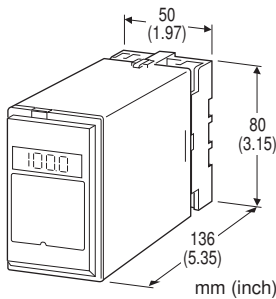

MODEL: WPT-[1][2][3]-[4][5]

ORDERING INFORMATION

- Code number: WPT-[1][2][3]-[4][5]
- Specify a code from below for each of [1] through [5].
(e.g. WPT-1AA-B/E/Q)
- Special output ranges (For codes Z & 0)
- Specify the specification for option code /Q
(e.g. /C01/S01)

Note: When the user requires a current and a voltage output, specify the current to be the Output 1 which allows a greater load.

[1] INPUT

Voltage

- 1: 0 - 110 V AC
- 2: 0 - 220 V AC
- 5: 0 - 150 V AC
- 6: 0 - 300 V AC

[2] OUTPUT 1

Current

- A: 4 - 20 mA DC (Load resistance 600 Ω max.)

- B: 2 - 10 mA DC (Load resistance 1200 Ω max.)
- C: 1 - 5 mA DC (Load resistance 2400 Ω max.)
- D: 0 - 20 mA DC (Load resistance 600 Ω max.)
- E: 0 - 16 mA DC (Load resistance 750 Ω max.)
- F: 0 - 10 mA DC (Load resistance 1200 Ω max.)
- G: 0 - 1 mA DC (Load resistance 12 kΩ max.)
- Z: Specify current (See OUTPUT SPECIFICATIONS)

Voltage

- 1: 0 - 10 mV DC (Load resistance 10 kΩ min.)
- 2: 0 - 100 mV DC (Load resistance 100 kΩ min.)
- 3: 0 - 1 V DC (Load resistance 1000 Ω min.)
- 4: 0 - 10 V DC (Load resistance 10 kΩ min.)
- 5: 0 - 5 V DC (Load resistance 5000 Ω min.)
- 6: 1 - 5 V DC (Load resistance 5000 Ω min.)
- 4W: -10 - +10 V DC (Load resistance 10 kΩ min.)
- 5W: -5 - +5 V DC (Load resistance 5000 Ω min.)
- 0: Specify voltage (See OUTPUT SPECIFICATIONS)

[3] OUTPUT 2

Current

- A: 4 - 20 mA DC (Load resistance 350 Ω max.)
- B: 2 - 10 mA DC (Load resistance 700 Ω max.)
- C: 1 - 5 mA DC (Load resistance 1400 Ω max.)
- D: 0 - 20 mA DC (Load resistance 350 Ω max.)
- E: 0 - 16 mA DC (Load resistance 430 Ω max.)
- F: 0 - 10 mA DC (Load resistance 700 Ω max.)
- G: 0 - 1 mA DC (Load resistance 7000 Ω max.)
- Z: Specify current (See OUTPUT SPECIFICATIONS)

Voltage

Same range availability as Output 1

[4] POWER INPUT

AC Power

- B: 100 V AC
- C: 110 V AC
- D: 115 V AC
- F: 120 V AC
- G: 200 V AC
- H: 220 V AC
- J: 240 V AC

DC Power

- S: 12 V DC
- R: 24 V DC
- V: 48 V DC
- P: 110 V DC

[5] OPTIONS (multiple selections)**Input Signal Indicator**

blank: Without

/E: With (0.0 - 100.0 % display)

Other Options

blank: none

/Q: Option other than the above (specify the specification)

SPECIFICATIONS OF OPTION: Q (multiple selections)**COATING (For the detail, refer to M-System's web site.)**

/C01: Silicone coating

/C02: Polyurethane coating

/C03: Rubber coating

TERMINAL SCREW MATERIAL

/S01: Stainless steel

GENERAL SPECIFICATIONS**Construction:** Plug-in**Connection:** M3.5 screw terminals**Screw terminal:** Chromated steel (standard) or stainless steel**Housing material:** Flame-resistant resin (black)**Isolation:** Input to output 1 to output 2 to power**Input waveform:** Up to 15 % of 3rd harmonic content**Overrange output:** 0 to 120 % at 1 - 5 V**Zero adjustment:** -5 to +5 % (front)**Span adjustment:** 95 to 105 % (front)

Adjustable individually for each output 1 and output 2.

■ DISPLAY (Input indicator)**LCD digital display:** 0.0 - 100.0 % (min. digit 0.1 %)

(No scaling)

INPUT SPECIFICATIONS**Frequency:** 50 or 60 Hz**Input burden:** 0.5 VA max.**Overload capacity:** 200 % of rating for 1 minute, 120 % continuous**Operational range:** 0 - 120 % of rating**OUTPUT SPECIFICATIONS****■ DC Current:** 0 - 20 mA DC**Minimum span:** 1 mA**Offset:** Max. 1.5 times span**Load resistance:** Output drive 12 V max. for Output 1;
7 V max. for Output 2**■ DC Voltage:** -10 - +12 V DC**Minimum span:** 5 mV**Offset:** Max. 1.5 times span**Load resistance:** Output drive 1 mA max. at ≥ 0.5 V**INSTALLATION****Power input****•AC:** Operational voltage range: rating ± 10 %, 50/60 ± 2 Hz, approx. 3 VA**•DC:** Operational voltage range: rating ± 10 %, or 85 - 150 V for 110 V rating, ripple 10 %p-p max., approx. 3 W (27 mA at 110 V)**Operating temperature:** -5 to +55°C (23 to 131°F)**Operating humidity:** 30 to 90 %RH (non-condensing)**Mounting:** Surface or DIN rail**Weight:** 350 g (0.77 lb)**PERFORMANCE in percentage of span****Accuracy:** ± 0.4 %**Display accuracy:** $\pm(0.4$ % of FS + 1 digit)**Temp. coefficient:** ± 0.02 %/°C (± 0.01 %/°F)**Response time:** ≤ 0.5 sec. (0 - 90 %)**Ripple:** 0.5 %p-p max.**Line voltage effect:** ± 0.1 % over voltage range**Insulation resistance:** ≥ 100 M Ω with 500 V DC**Dielectric strength:** 2000 V AC @1 minute

(input to output to power to ground)

1000 V AC @ 1 minute (output 1 to output 2)

EXTERNAL DIMENSIONS & TERMINAL ASSIGNMENTS unit: mm (inch)

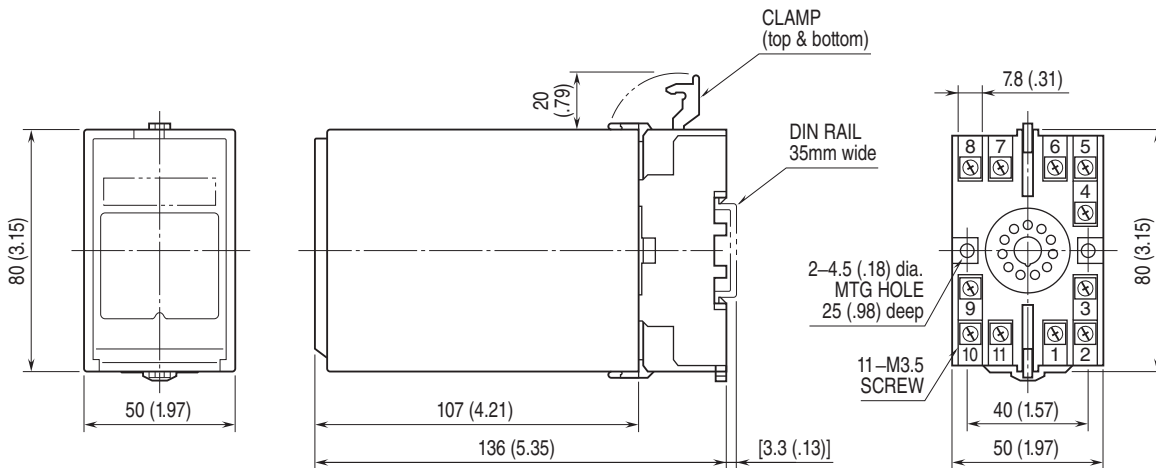

• When mounting, no extra space is needed between units.

SCHEMATIC CIRCUITRY & CONNECTION DIAGRAM

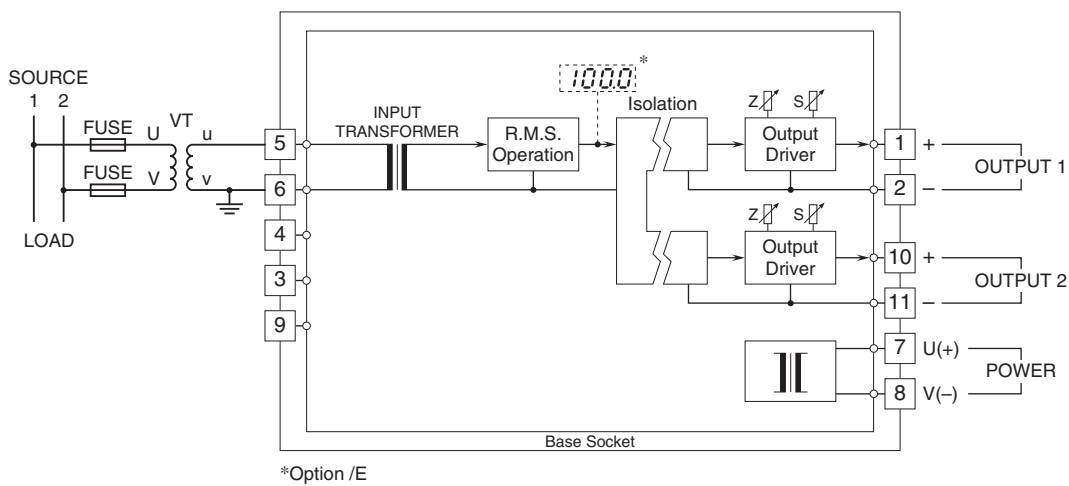

Specifications are subject to change without notice.