

TEMPERATURE CONTROLLER
(Modbus, 5 digit, LED display type, size 96 × 96 mm)

MODEL **TC10EM**

BEFORE USE

Thank you for choosing us. Before use, please check contents of the package you received as outlined below.

If you have any problems or questions with the product, please contact our sales office or representatives.

■ PACKAGE INCLUDES:

- Temperature controller (controller + CJC sensor, 2 pcs) ..(1)
- Mounting bracket.....(2)
- Watertight packing(1)
- Ferrite core (TDK ZCAT 3035-1330).....(1)
- Engineering unit label sheet.....(1)

■ MODEL NO.

Confirm Model No. marking on the product to be exactly what you ordered.

■ INSTRUCTION MANUAL

This manual describes necessary points of caution when you use this product, including installation, connection and basic maintenance procedures. For detailed explanations, please refer to the Model TC10EM operating manual (EM-9581-B).

This controller is programmable by using the PC Configurator Software. For detailed information on the PC configuration, refer to the TC10CFG users manual. The TC10CFG PC Configurator Software is downloadable at our web site.

POINTS OF CAUTION

■ CONFORMITY WITH EU DIRECTIVES

- This equipment is suitable for Pollution Degree 2 and Installation Category II (transient voltage 2500V). Reinforced insulation (signal input to output to power input: 300V) and basic insulation (signal input or output to power input to Modbus: 300V) are maintained. Prior to installation, check that the insulation class of this unit satisfies the system requirements.
- Altitude up to 2000 meters.
- The equipment must be installed such that appropriate clearance and creepage distances are maintained to conform to CE requirements. Failure to observe these requirements may invalidate the CE conformance.
- The actual installation environments such as panel configurations, connected devices, connected wires, may affect the protection level of this unit when it is integrated in a panel system. The user may have to review the CE requirements in regard to the whole system and employ additional protective measures* to ensure the CE conformity.
 - * For example, installation of noise filters and clamp filters for the power source, input and output connected to the unit, etc.
- In order to enable the operator to turn off the power input immediately, install a switch or a circuit breaker according to the relevant requirements in IEC 60947-2 and properly indicate it.

■ POWER INPUT RATING & OPERATIONAL RANGE

- Locate the power input rating marked on the product and confirm its operational range as indicated below:
100 – 240V AC rating: 85 – 264V, 47 – 66 Hz, approx. 6 – 8 VA

■ ENVIRONMENT

- Indoor use.
- When heavy dust or metal particles are present in the air, install the unit inside proper housing with sufficient ventilation.
- Do not install the unit where it is subjected to continuous vibration. Do not subject the unit to physical impact.
- Environmental temperature must be within -10 to +55°C (14 to 131°F) with relative humidity within 5 to 90% RH in order to ensure adequate life span and operation.

■ REQUIREMENTS TO ENSURE IP65

- Observe the designated panel cutout size (W92 × H92 mm).
- The watertight packing included in the product package must be placed behind the front cover.
- Tighten screws of the brackets until the unit is fixed to the panel. (torque 0.5 N·m)
- Confirm visually that the sealing is not contorted or excessively run off the edge after installation.

■ WIRING

- Do not install cables close to noise sources (relay drive cable, high frequency line, etc.).
- Do not bind these cables together with those in which noises are present. Do not install them in the same duct.
- Twist the power cables 1 turn around the ferrite core at near the unit as shown below.

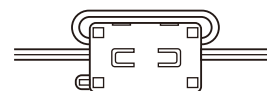

■ UNUSED INPUT CHANNELS

- Unused channels can be specified and set to DC voltage input with the PC Configurator Software (model: TC-10CFG) or operation buttons on the front of the product to prevent possible errors caused by open field terminals.

■ AND

- The unit is designed to function as soon as power is supplied, however, a warm up for 10 minutes is required for satisfying complete performance described in the data sheet.
- With voltage output, do not leave the output terminals shortcircuited for a long time. The unit is designed to endure it without breakdown, however, it may shorten appropriate life duration.

COMPONENT IDENTIFICATION

FRONT VIEW

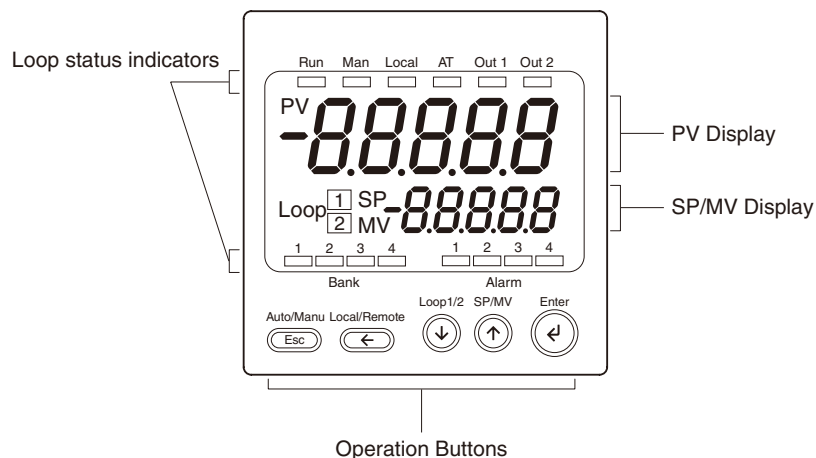

REAR VIEW

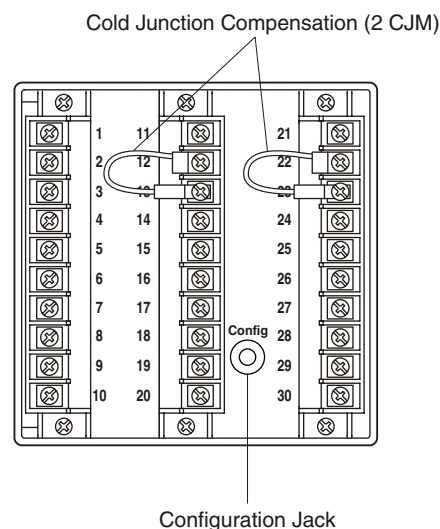

LOOP STATUS INDICATOR

- Run : Green LED turns on while loop is in operation.
- Man : Green LED turns on during manual mode.
- Local : Green LED turns on when local SP is selected.
- AT : Green LED turns on during auto-tuning.
- Out1 : Green LED turns on during heating control output.
- Out2 : Green LED turns on during cooling control output.
- Loop1 : Amber LED turns on when loop 1 is chosen.
- Loop2 : Amber LED turns on when loop 2 is chosen.
- Bank1 : Green LED turns on when bank 1 is chosen.
- Bank2 : Green LED turns on when bank 2 is chosen.
- Bank3 : Green LED turns on when bank 3 is chosen.
- Bank4 : Green LED turns on when bank 4 is chosen.
- Alarm1: Red LED turns on at alarm 1.
- Alarm2: Red LED turns on at alarm 2.
- Alarm3: Red LED turns on at alarm 3.
- Alarm4: Red LED turns on while setting is saving to the non-volatile memory.

EXTERNAL DIMENSIONS unit: mm [inch]

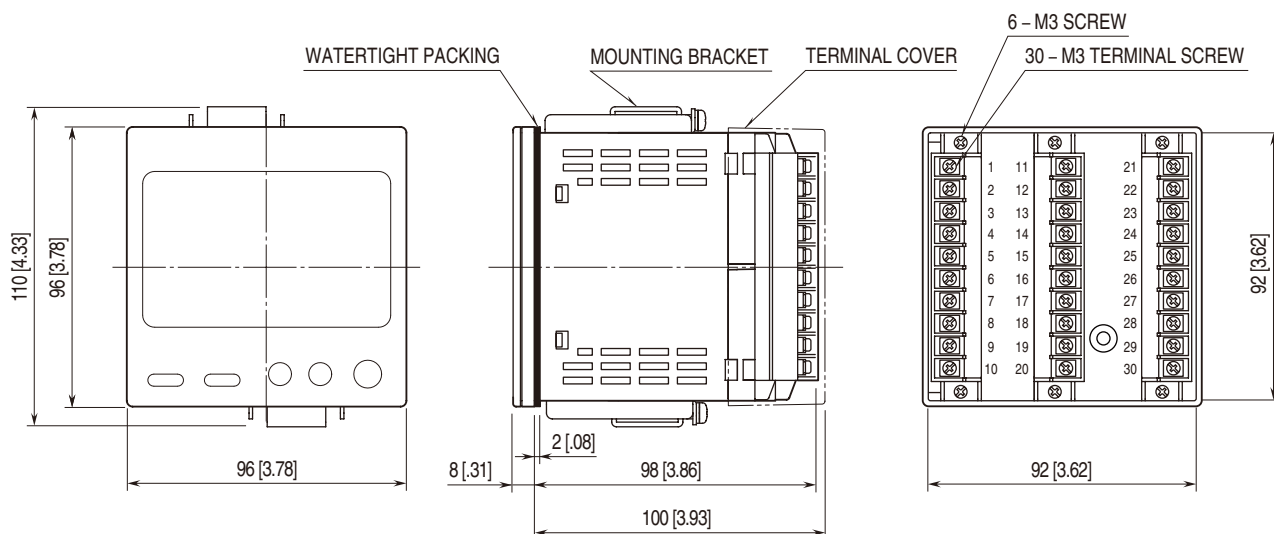

INSTALLATION

■ PANEL CUTOUT unit: mm [inch]

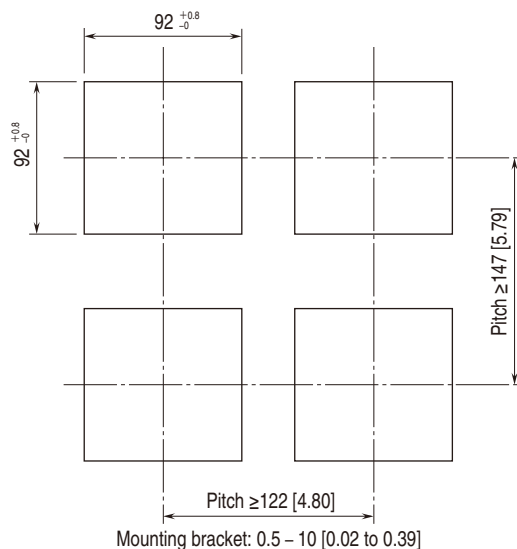

■ CAUTION

- Degree of protection, IP65 is applicable to the front panel of the unit with single mounting according to the specified panel cutout. Not applicable in case of re-mounting. After installation ensure waterproof of the mounting.
- Install the unit to vertical panel so that its function buttons are at the bottom side. Installing by other direction will cause degradation of life span or performance due to rise of the internal temperature.
- Ensure that there is sufficient space for ventilation inside a panel. Do not install above the devices that generate high heat such as heaters, transformers or resistors. Observe at the minimum of 55 mm (2.2") in vertical direction, minimum of 30 mm (1.2") in horizontal direction for maintenance purpose.

■ HOW TO MOUNT THE UNIT ON A PANEL

- 1) Remove the mounting brackets.
- 2) Remove the terminal cover and insert it into the panel cutout prior to insertion of the unit.
- 3) Insert the unit into the panel cutout. The watertight packing must be in place to conform degree of protection, IP65. Do not remove it.
- 4) Hang the hooks of the mounting brackets at the square holes on the upper and bottom side of the unit. Tighten screws of the brackets until the unit is fixed to the panel. (torque 0.5 N·m)

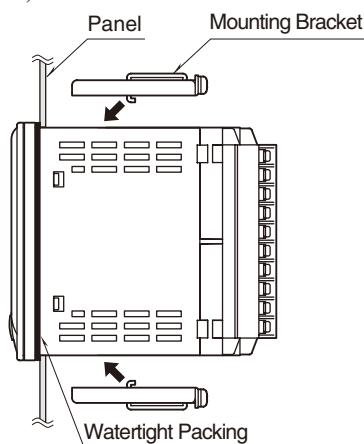

■ HOW TO REMOVE THE TERMINAL COVER

Insert the minus tip of a screwdriver into each hole at the four corners of the cover and pull it to the direction as indicated below to separate the terminal cover.

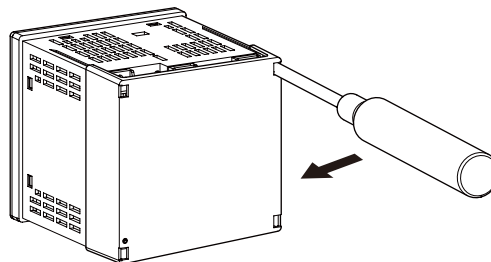

■ HOW TO REMOVE THE TERMINAL BLOCK

- The terminal block is separable in two pieces. Loosen two screws on top and bottom of the terminal block to separate.
- Be sure to turn off the power supply, input/output signal and communication signal before separating the terminal block.
- Each terminal block has ID keys so that it can be inserted to applicable terminal socket only.

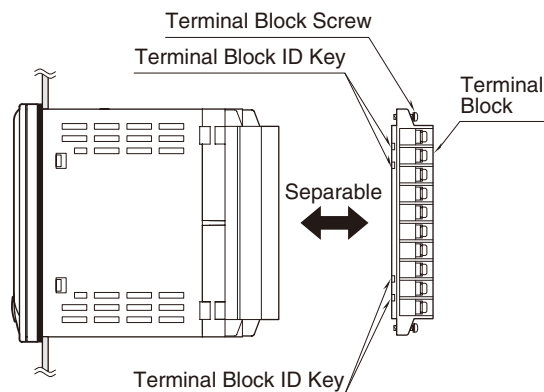

LIGHTNING SURGE PROTECTION

We offer a series of lightning surge protector for protection against induced lightning surges. Please contact us to choose appropriate models.

TERMINAL CONNECTIONS

■ CONTROL OUTPUT: A, V and P

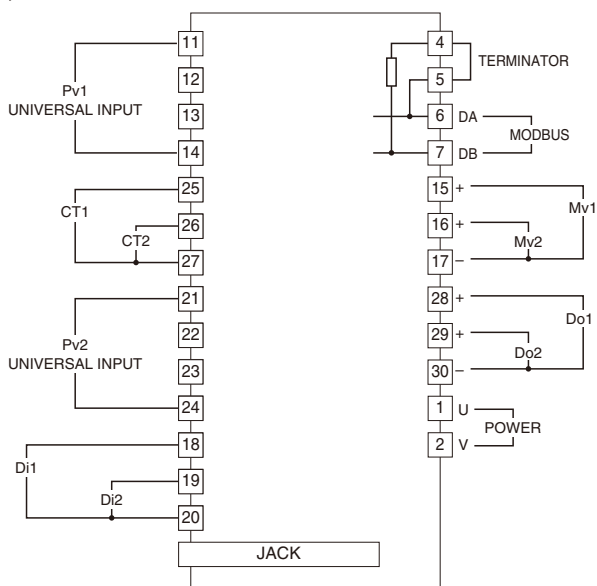

■ UNIVERSAL INPUT CONNECTION (Pv1) e.g.

- DC Voltage (-10 ~ +10V DC)
- DC Current (0 ~ 20mA DC)

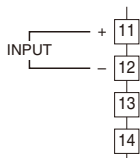

- DC Voltage (-1000 ~ +1000mV DC)

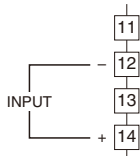

•Thermocouple

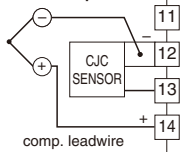

•RTD/Resistor (3-wire)

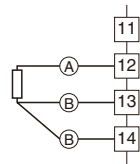

•RTD/Resistor (2-wire)

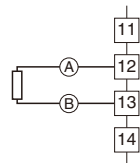

•Potentiometer

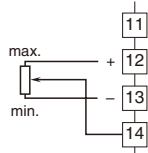

■ UNIVERSAL INPUT CONNECTION (Pv2) e.g.

- DC Voltage (-10 ~ +10V DC)
- DC Current (0 ~ 20mA DC)

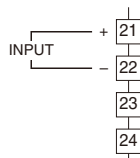

- DC Voltage (-1000 ~ +1000mV DC)

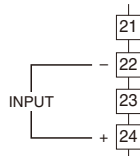

•Thermocouple

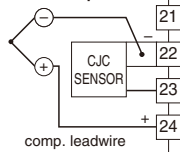

•RTD/Resistor (3-wire)

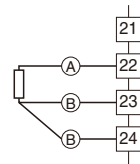

•RTD/Resistor (2-wire)

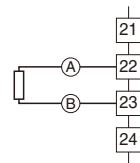

•Potentiometer

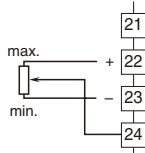

■ CT1 / CT2 CONNECTION e.g.

- Clamp-on current Sensor (model : CLSE)

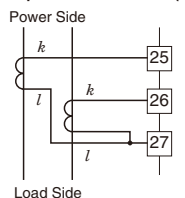

■ DISCRETE INPUT CONNECTION e.g.

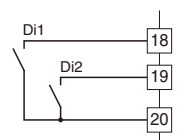

■ CONTROL OUTPUT 1 & 2 CONNECTION e.g.

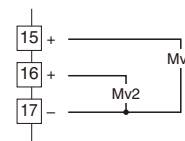

■ CONTROL OUTPUT 3 & 4 CONNECTION e.g.

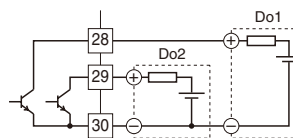

■ CONTROL OUTPUT: R

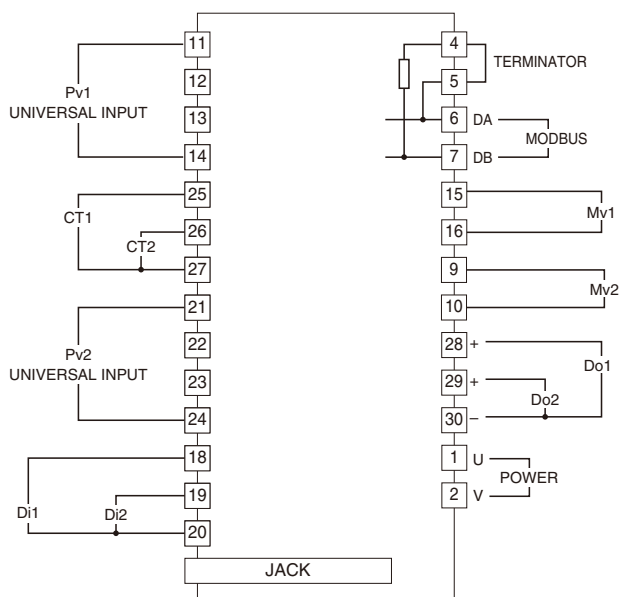

■ UNIVERSAL INPUT CONNECTION (Pv1) e.g.

- DC Voltage (-10 ~ +10V DC)
- DC Current (0 ~ 20mA DC)

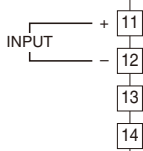

•DC Voltage (-1000 ~ +1000mV DC)

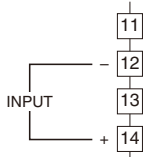

•Thermocouple

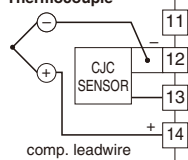

•RTD/Resistor (3-wire)

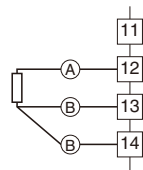

•RTD/Resistor (2-wire)

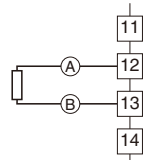

•Potentiometer

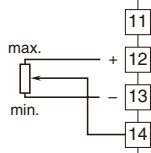

■ UNIVERSAL INPUT CONNECTION (Pv2) e.g.

- DC Voltage (-10 ~ +10V DC)
- DC Current (0 ~ 20mA DC)

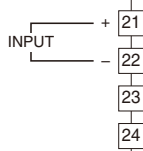

•DC Voltage (-1000 ~ +1000mV DC)

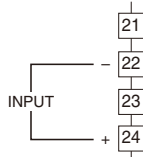

•Thermocouple

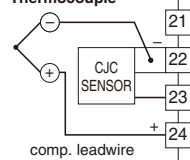

•RTD/Resistor (3-wire)

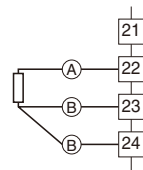

•RTD/Resistor (2-wire)

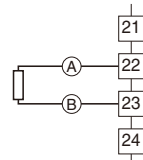

•Potentiometer

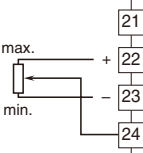

■ CT1 / CT2 CONNECTION e.g.

- Clamp-on current Sensor (model : CLSE)

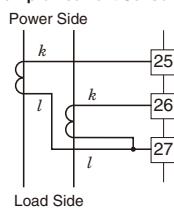

■ DISCRETE INPUT CONNECTION e.g.

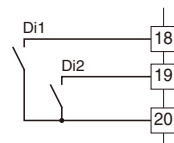

■ CONTROL OUTPUT 1 CONNECTION e.g.

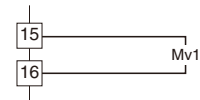

■ CONTROL OUTPUT 2 CONNECTION e.g.

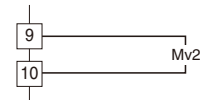

■ CONTROL OUTPUT 3 & 4 CONNECTION e.g.

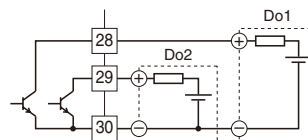

■ CONTROL OUTPUT: A1, V1 and P1

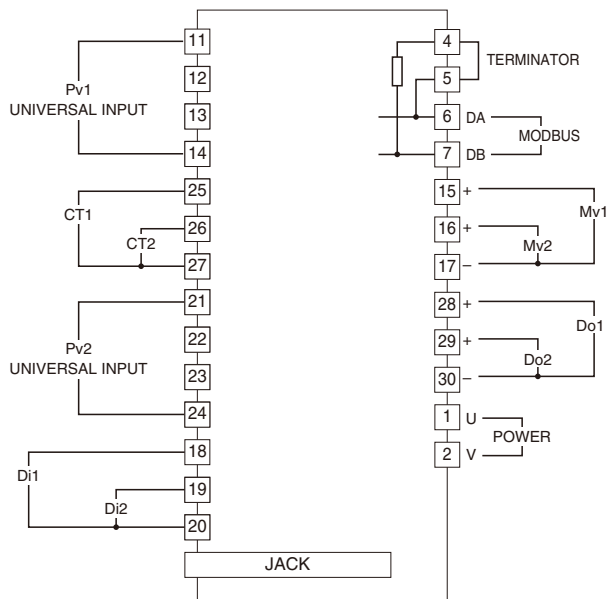

■ UNIVERSAL INPUT CONNECTION (Pv1) e.g.

- DC Voltage (-10 – +10V DC)
- DC Current (0 – 20mA DC)

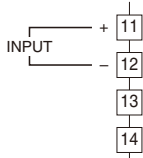

•DC Voltage (-1000 – +1000mV DC)

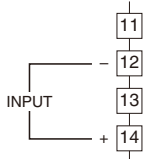

•Thermocouple

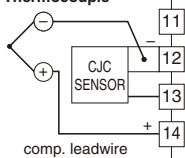

•RTD/Resistor (3-wire)

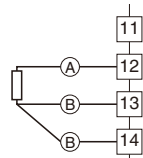

•RTD/Resistor (2-wire)

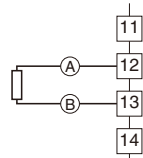

•Potentiometer

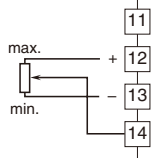

■ UNIVERSAL INPUT CONNECTION (Pv2) e.g.

- DC Voltage (-10 – +10V DC)
- DC Current (0 – 20mA DC)

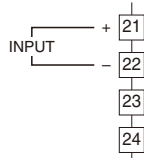

•DC Voltage (-1000 – +1000mV DC)

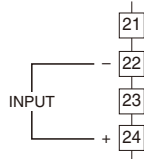

•Thermocouple

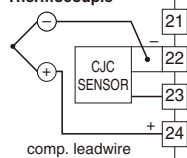

•RTD/Resistor (3-wire)

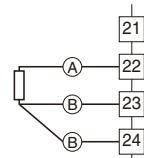

•RTD/Resistor (2-wire)

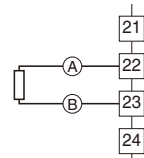

•Potentiometer

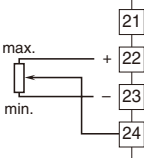

■ CT1 / CT2 CONNECTION e.g.

- Clamp-on current Sensor (model : CLSE)

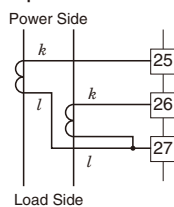

■ DISCRETE INPUT CONNECTION e.g.

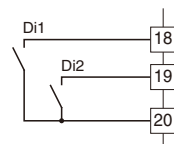

■ CONTROL OUTPUT 1 & 2 CONNECTION e.g.

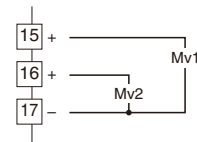

■ CONTROL OUTPUT 3 & 4 CONNECTION e.g.

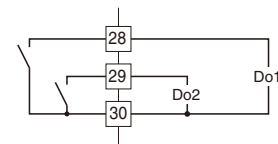

■ CONTROL OUTPUT: R1

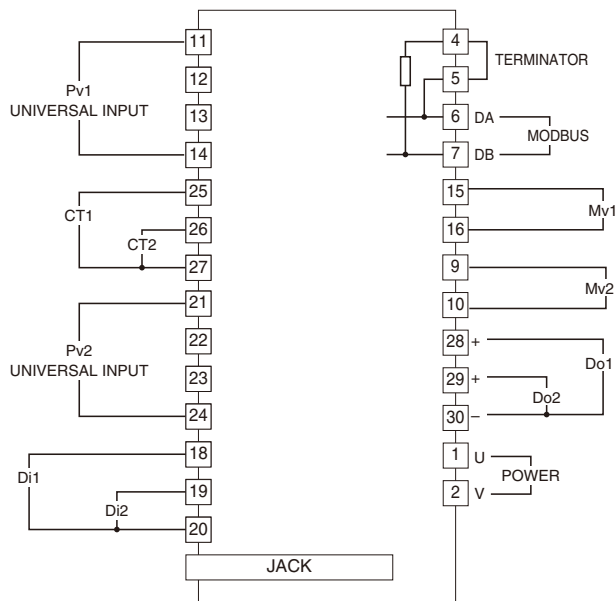

■ UNIVERSAL INPUT CONNECTION (Pv1) e.g.

- DC Voltage (-10 – +10V DC)
- DC Current (0 – 20mA DC)

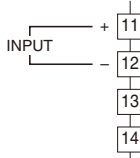

- DC Voltage (-1000 – +1000mV DC)

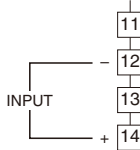

•Thermocouple

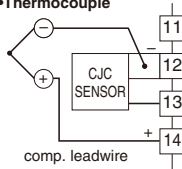

•RTD/Resistor (3-wire)

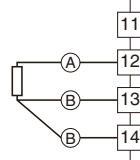

•RTD/Resistor (2-wire)

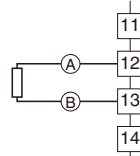

•Potentiometer

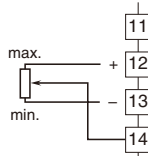

■ UNIVERSAL INPUT CONNECTION (Pv2) e.g.

- DC Voltage (-10 – +10V DC)
- DC Current (0 – 20mA DC)

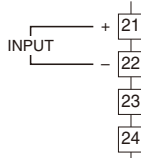

- DC Voltage (-1000 – +1000mV DC)

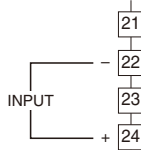

•Thermocouple

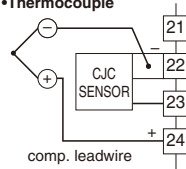

•RTD/Resistor (3-wire)

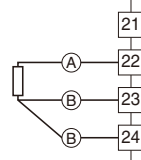

•RTD/Resistor (2-wire)

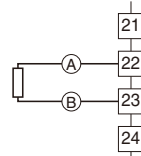

•Potentiometer

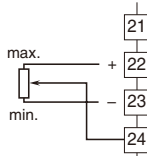

■ CT1 / CT2 CONNECTION e.g.

- Clamp-on current Sensor (model : CLSE)

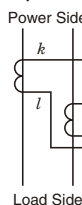

■ DISCRETE INPUT CONNECTION e.g.

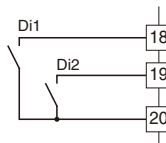

■ CONTROL OUTPUT 1 CONNECTION e.g.

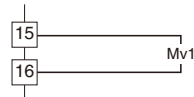

■ CONTROL OUTPUT 2 CONNECTION e.g.

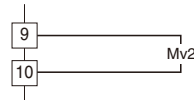

■ CONTROL OUTPUT 3 & 4 CONNECTION e.g.

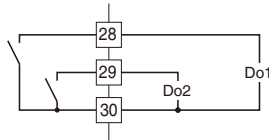

CONNECTION DIAGRAMS

MASTER CONNECTION

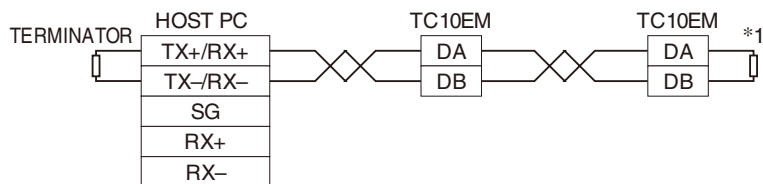

NO.	ID	FUNCTION
6	DA	DA
7	DB	DB

*1. For using internal terminator, short-across terminals 4 and 5.

SCREW TERMINAL

Torque: 0.5 N·m

SOLDERLESS TERMINAL

Refer to the drawing on the right.

Recommended manufacturer: Japan Solderless Terminal

MFG.Co.Ltd, Nichifu Co.,Ltd

Applicable wire size: 0.25 to 1.65 mm² (AWG 22 to 16)

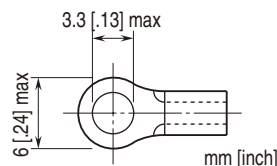

SYSTEM CONFIGURATIONS & CONTROL EXAMPLES

1 loop heating ON/OFF control and heater wire break detection

1. Installation example:

- Temperature Controller (model: TC10EM)
- Clamp-on Current Sensor (model: CLSE)
- Oven
- Heater
- Relay
- Temperature sensor

2. Process until start operating:

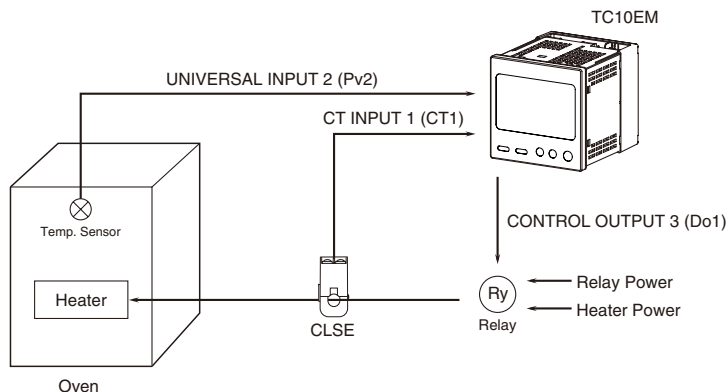
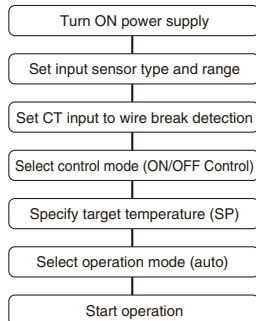

1 loop heating and cooling control (PID)

1. Installation example:

- Temperature Controller (model: TC10EM)
- Object to heat/cool
- Temperature sensor

2. Process until start operating:

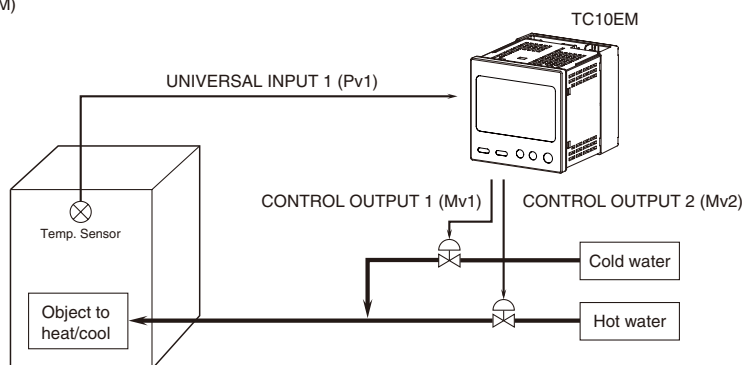
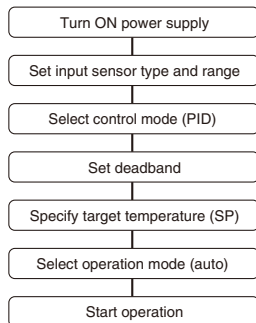

Note: The examples above are for single loop, however, dual loop control is also available using only one TC10EM.