

Single Loop Controller Series

BARGRAPH INDICATING ALARM

(with 4-digit digital meter, LED bar indicator)

Functions & Features

- Panel designed to match the SC series controllers.
- Displays a process variable in graphic bargraph of 101 LED segments
- 3 input channels
- Clear 4-digit digital meter
- Provides max. 4 alarm contact outputs
- LED brightness adjustments
- IP55 front cover
- Multi-color indicator (red, orange and green)
- Scale plate is easily replaceable

Typical Applications

- Panel operation for small-scale instrumentation
- Various alarm applications

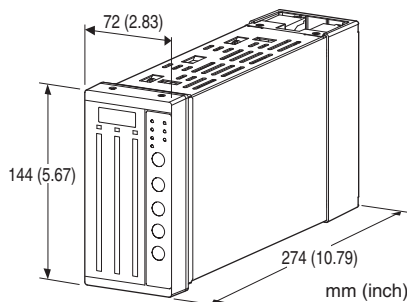

MODEL: SD10-[1][2][3][4][5][6][7][8][9]-[10]

ORDERING INFORMATION

- Code number: SD10-[1][2][3][4][5][6][7][8][9]-[10]
Specify a code from below for each [1] through [10].
(e.g. SD10-RYGAA0A6Y-M2)
- Use Ordering Information Sheet (No. ESU-6341) for the I/O codes, digital display range, decimal point position and alarm setpoint.
- Bargraph range (Refer to 'SCALE PLATE')

[1] BAR LED COLOR (INPUT 1)

- R: Red
- Y: Amber
- G: Green
- B: Blue
- 1: Multi-color (red, orange and green), (See 'External View.')

[2] BAR LED COLOR (INPUT 2)

Same color availability as Input 1

[3] BAR LED COLOR (INPUT 3)

Same color availability as Input 1

[4] INPUT 1

Current

A: 4 - 20 mA DC (Input resistance 10 Ω)
Z: Specify current (See INPUT SPECIFICATIONS)

Voltage

6: 1 - 5 V DC (Input resistance 1 MΩ min.)
0: Specify voltage (See INPUT SPECIFICATIONS)

[5] INPUT 2

Same range availability as Input 1

[6] INPUT 3

Same range availability as Input 1

[7] DC OUTPUT 1

Y: Without

Current

A: 4 - 20 mA DC (Load resistance 550 Ω max.)
D: 0 - 20 mA DC (Load resistance 550 Ω max.)

Voltage

6: 1 - 5 V DC (Load resistance 10 kΩ min.)
0: Specify voltage (See OUTPUT SPECIFICATIONS)

[8] DC OUTPUT 2

Same range availability as DC Output 1

[9] DC OUTPUT 3

Same range availability as DC Output 1

[10] POWER INPUT

AC Power

M2: 100 - 240 V AC (Operational voltage range 85 - 264 V, 47 - 66 Hz)

DC Power

R: 24 V DC
(Operational voltage range 24 V ±10 %, ripple 10 %p-p max.)

SPARE PARTS

- Scale plate

GENERAL SPECIFICATIONS

Construction: Panel flush mounting
Degree of protection: IP55; applicable to the front panel for single unit mounted according to the specified panel cutout
Connection: M3.5 screw terminals (torque 1.0 N·m)
Screw terminal: Nickel-plated steel
Housing material: Flame-resistant resin (gray), steel
Isolation: Input 1 to input 2 to input 3 to supply output to DC output 1 to DC output 2 to DC output 3 to alarm output 1 to alarm output 2 to alarm output 3 to power to FG
Display zero adjustment (bargraph): -19 to +19 %
DC output zero adjustment: -19 to +19 %
Display span adjustment (bargraph): 81 to 119 %
DC output span adjustment: 81 to 119 %
Scale plate: Flame resistant resin (white scale & characters on black base)
H & L alarm output delay: 0 sec. (factory setting; fieldselectable between 0 and 15 sec. by 1 sec. increments)

Setpoint adjustment

HH [H setpoint] to 100 %
 H [L setpoint] to [HH setpoint]
 L [LL setpoint] to [H setpoint]
 LL 0 % to [L setpoint]

Alarm deadband (hysteresis): 1 %

■ BARGRAPH

3 Bar-LEDs indicate scaled Input 1, 2 and 3 from 0 to 100 %.
LED: 101 segments, 100 mm (3.94") height, 3.0 mm (.12") width
Display range: 0 to 100
Number of digits: Max. 4 digits (including decimal point and negative sign)
Divisions: 22 - 100
Engineering unit: max. 6 characters

Engineering unit: max. 6 characters

Bargraph display scale plate

- Detachable structure
- White characters on black base
- Max. 4 digits (including decimal point and negative sign)
- 22 - 100 divisions
- Engineering unit of 6 characters

■ DIGITAL DISPLAYS

With the Input indication selector (IND) display Input 1, 2 and 3 scaling values.

LED: Red; 4 digits; 10 mm (0.39") height, 24 mm (0.94") width

Scaled range: -1999 to 0 to 9999

(Min. 3 significant digits)

Minimum scale value: 100 (3 digits, the decimal point position disregarded)

Overrange: The indicator blinks when the input is out of the range from -15 to +115 %.

The indicator shows '----' when the value after scaling is out of the range.

Decimal point position: 10^{-1} , 10^{-2} , 10^{-3} or none

Zero indication: Higher-digit zeros are suppressed

■ LED BRIGHTNESS ADJUSTMENTS

3 levels of brightness available for the bargraph and the digital indicator. (except alarm and mode setting status LED)

Read rate: 5/s

Moving average sample number: 4 (factory setting; field selectable among 1, 2, 4, 8 or 16)

SUPPLY OUTPUT

Output voltage:

24 V DC ± 10 % with no load

18 V DC min. at 20 mA

Current rating: ≤ 22 mA DC

• Shortcircuit protection

Current limited: Approx. 30 mA

INPUT SPECIFICATIONS

■ **DC Current:** 0 - 50 mA DC; input resistor incorporated

Minimum span: 1 mA

When specifying a resistance value, choose from below.

5.1 Ω , 10 Ω , 12 Ω , 20 Ω , 39 Ω , 200 Ω

Refer to the Ordering Information Sheet (No. ESU-6341).

Offset: Max. 1.5 times span

■ **DC Voltage:** -10 - +10 V DC

Input resistance: ≥ 1 M Ω

Minimum span: 0.1 V

Offset: Max. 1.5 times span

OUTPUT SPECIFICATIONS

■ DC Current

Choose output range from below.

4 - 20 mA DC (Load resistance 550 Ω max.)

0 - 20 mA DC (Load resistance 550 Ω max.)

For details, refer to the Ordering Information Sheet.

■ DC Voltage

Choose output range from below.

0 - 1 V DC (Load resistance 2000 Ω min.)

0 - 10 V DC (Load resistance 20 k Ω min.)

0 - 5 V DC (Load resistance 10 k Ω min.)

1 - 5 V DC (Load resistance 10 k Ω min.)

-10 - +10 V DC (Load resistance 20 k Ω min.)

-5 - +5 V DC (Load resistance 10 k Ω min.)

For details, refer to the Ordering Information Sheet.

■ **Alarm Output:** Relay contact

Rated load: 240 V AC @ 1 A ($\cos \phi = 1$)

30 V DC @ 1 A (resistive load)

Maximum switching voltage: 250 V AC or 30 V DC

Maximum switching power: 250 VA or 60 W

Minimum load: 5 V DC @ 10 mA

Mechanical life: 2×10^7 cycles

INSTALLATION

Power consumption

AC:

Approx. 14 VA at 100 V

Approx. 17 VA at 200 V

Approx. 19 VA at 264 V

• **DC:** Approx. 7.3 W

Operating temperature: -5 to +55°C (23 to 131°F)

Operating humidity: 5 to 90 %RH (non-condensing)

Mounting: Panel flush mounting (high-density mounting in horizontal direction)

Weight: 1.8 kg (4.0 lbs)

PERFORMANCE in percentage of span

Accuracy: Input accuracy + output accuracy

• **Input accuracy:** $\pm 0.1\%$

• **Output accuracy:**

$\pm 0.1\%$ DC output

$\pm 1\%$ ± 1 digit (bargraph)

$\pm 0.1\%$ ± 1 digit (digital indicator)

Temp. coefficient: $\pm 0.015\%/^{\circ}\text{C}$ ($\pm 0.008\%/^{\circ}\text{F}$)

Response time: ≤ 0.5 sec. (0 - 90%, moving average sample number set to 4)

Line voltage effect: $\pm 0.1\%$ over voltage range

Insulation resistance: ≥ 100 M Ω with 500 V DC

Dielectric strength:

1500 V AC @ 1 minute (Input 1 or Input 2 or input 3 or supply output to DC output 1 or DC output 2 or DC output 3 to alarm output 1 or alarm output 2 or alarm output 3 to power to FG)

500 V AC @ 1 minute (Input 1 to Input 2 to input 3 to supply output)

500 V AC @ 1 minute (DC output 1 to DC output 2 to DC output 3)

500 V AC @ 1 minute (alarm output 1 to alarm output 2 to alarm output 3)

SCALE PLATE

■ WHAT MUST BE SPECIFIED WHEN ORDERING

Please specify the bargraph scale range and engineering unit. The overall scale plate design including the number of divisions, division line length, character font is determined by M-System.

[Example] : Bargraph range 0 to 300 cm
 Bargraph scale range: 0 – 300
 Engineering unit for the bargraph: cm

■ TYPES OF DIVISIONS

Five (5) types of divisions are used depending upon the scale span, which determined by the following equation:

$$\text{Scale Span} = (\text{Max. range value} - \text{Min. range value}) \times 10^n$$

where n = integer (used to limit the calculated scale span to the minimum of 1.1, below 11.0.)

The number of divisions is automatically determined by the scale span.

• Type 1: $1.1 \leq \text{Scale Span} < 1.3$

Number of divisions: 22 to 25.9

Scale: Starts at 0, increments by 0.02 / 0.2 / 2 / 20 / 200. Min. and max. values indicated. 4 digits including negative sign and decimal point.

Division lines: Long, Short, Medium, Short, Long (4 divisions repeated)

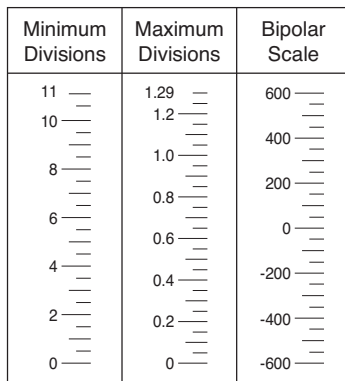

• Type 3: $2.0 \leq \text{Scale Span} < 2.6$

Number of divisions: 40 to 51.9

Scale: Starts at 0, increments by 0.05 / 0.5 / 5 / 50 / 500. Min. and max. values indicated. 4 digits including negative sign and decimal point.

Division lines: Long, Short, Medium, Short, Medium, Short, Long (10 divisions repeated)

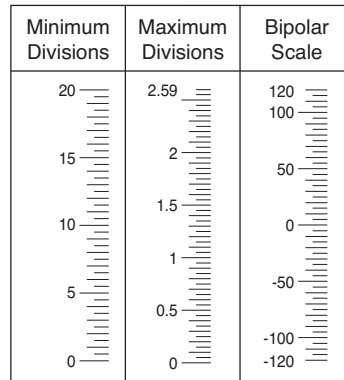

• Type 2: $1.3 \leq \text{Scale Span} < 2.0$

Number of divisions: 26 to 39.9

Scale: Starts at 0, increments by 0.03 / 0.3 / 3 / 30 / 300. Min. and max. values indicated. 4 digits including negative sign and decimal point.

Division lines: Long, Short, Medium, Short, Medium, Short, Long (6 divisions repeated)

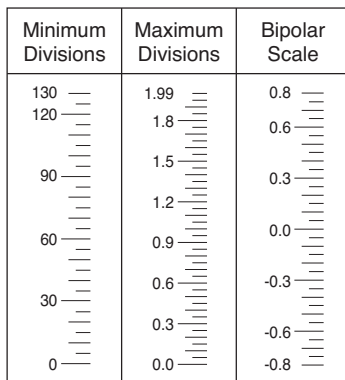

• Type 4: $2.6 \leq \text{Scale Span} < 5.5$

Number of divisions: 26 to 54.9

Scale: Starts at 0, increments by 0.05 / 0.5 / 5 / 50 / 500. Min. and max. values indicated. 4 digits including negative sign and decimal point.

Division lines: Long, Medium, Medium, Medium, Medium, Long (5 divisions repeated)

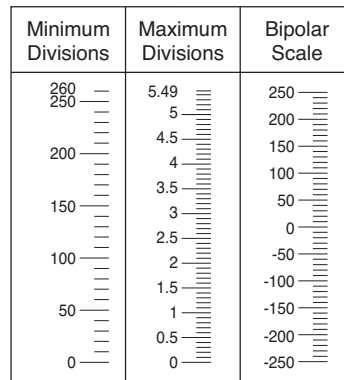

• **Type 5: 5.5 Scale Span < 11.0**

Number of divisions: 27.5 to 54.9

Scale: Starts at 0, increments by 0.01 / 0.1 / 1 / 10 / 100 / /1000. Min. and max. values indicated. 4 digits including negative sign and decimal point.

Division lines: Long, Medium, Medium, Medium, Medium, Long
(5 divisions repeated)

Minimum Divisions	Maximum Divisions	Bipolar Scale
550	10.9	0.5
500	10	0.4
	9	0.3
400	8	0.2
	7	0.1
300	6	0
	5	-0.1
200	4	-0.2
	3	-0.3
100	2	-0.4
	1	-0.4
0	0	-0.5

EXTERNAL VIEW

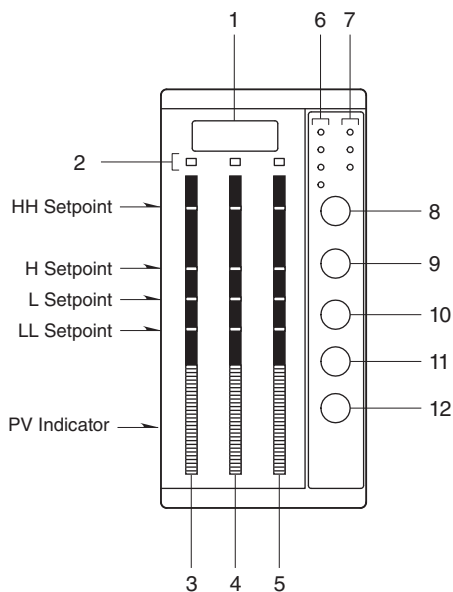

1. Digital meter
2. Digital meter Selector LED
(Displays which of the 3 inputs value is indicating)
3. Input 1 bargraph meter
4. Input 2 bargraph meter
5. Input 3 bargraph meter
6. Alarm indicator
7. Mode setting status LED
8. Input indication selector (IND)
9. Mode selector (M)
10. Manual operation button (UP)
11. Acceleration button (FAST)
(Accelerates the operation by pressing simultaneously with UP or DOWN button)
12. Manual operation button (DOWN)

• **Bar Color Pattern**

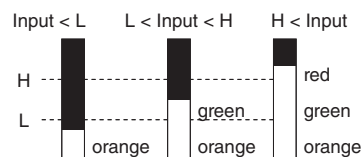

EXTERNAL DIMENSIONS & TERMINAL ASSIGNMENTS unit: mm (inch)

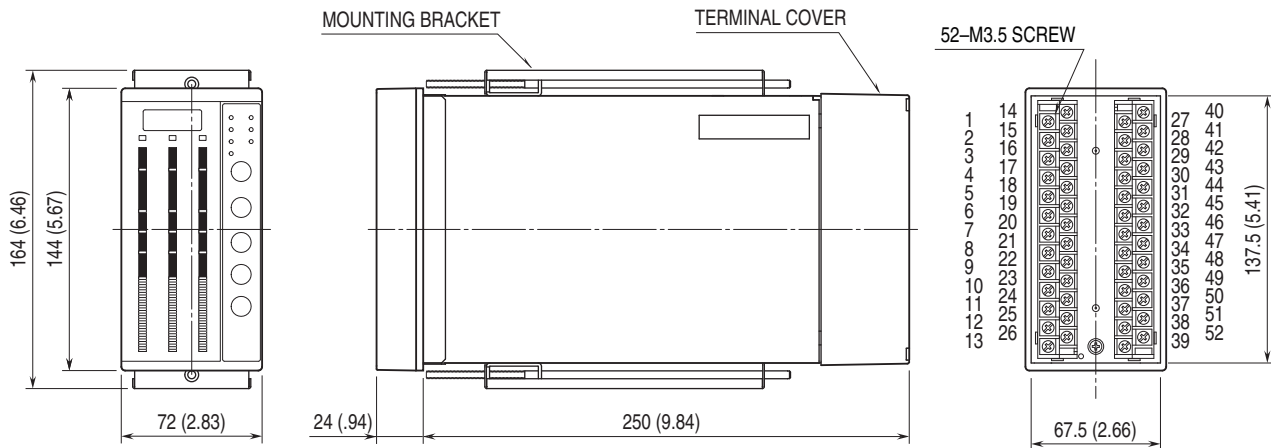

PANEL CUTOUT unit: mm

■ PANEL CUTOUT unit: mm

• Single mounting

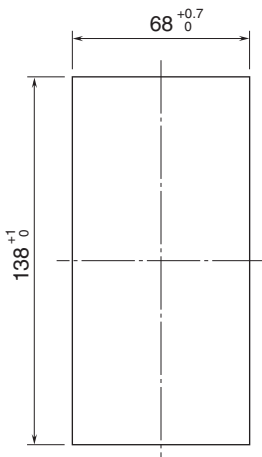

• Clustered mounting

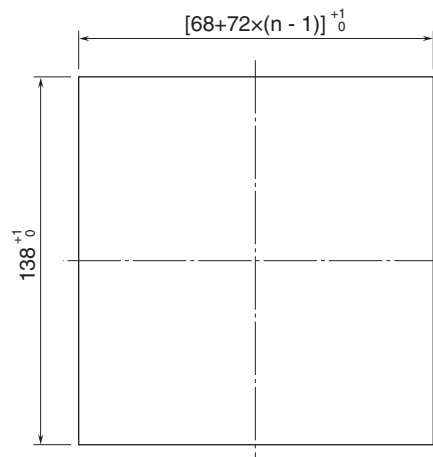

n = number of units

Panel thickness 2.3 – 20

■ CAUTION

- Degree of protection, IP55 is applicable to the front panel of the unit with single mounting according to the specified panel cutout. Ensure that there is no compromise in the unit's protection against water and dust after installation.
- Install the unit to vertical panel so that its digital meter is at the upper side. Installing by other direction will cause degradation of life span or performance due to rise of the internal temperature.
- Ensure that there is sufficient space for ventilation inside a panel. Do not install above the devices that generate high temperature such as heaters, transformers or resistors. Observe at the minimum of 30 mm (1.2") in all directions for maintenance purpose.

SCHEMATIC CIRCUITRY & CONNECTION DIAGRAM

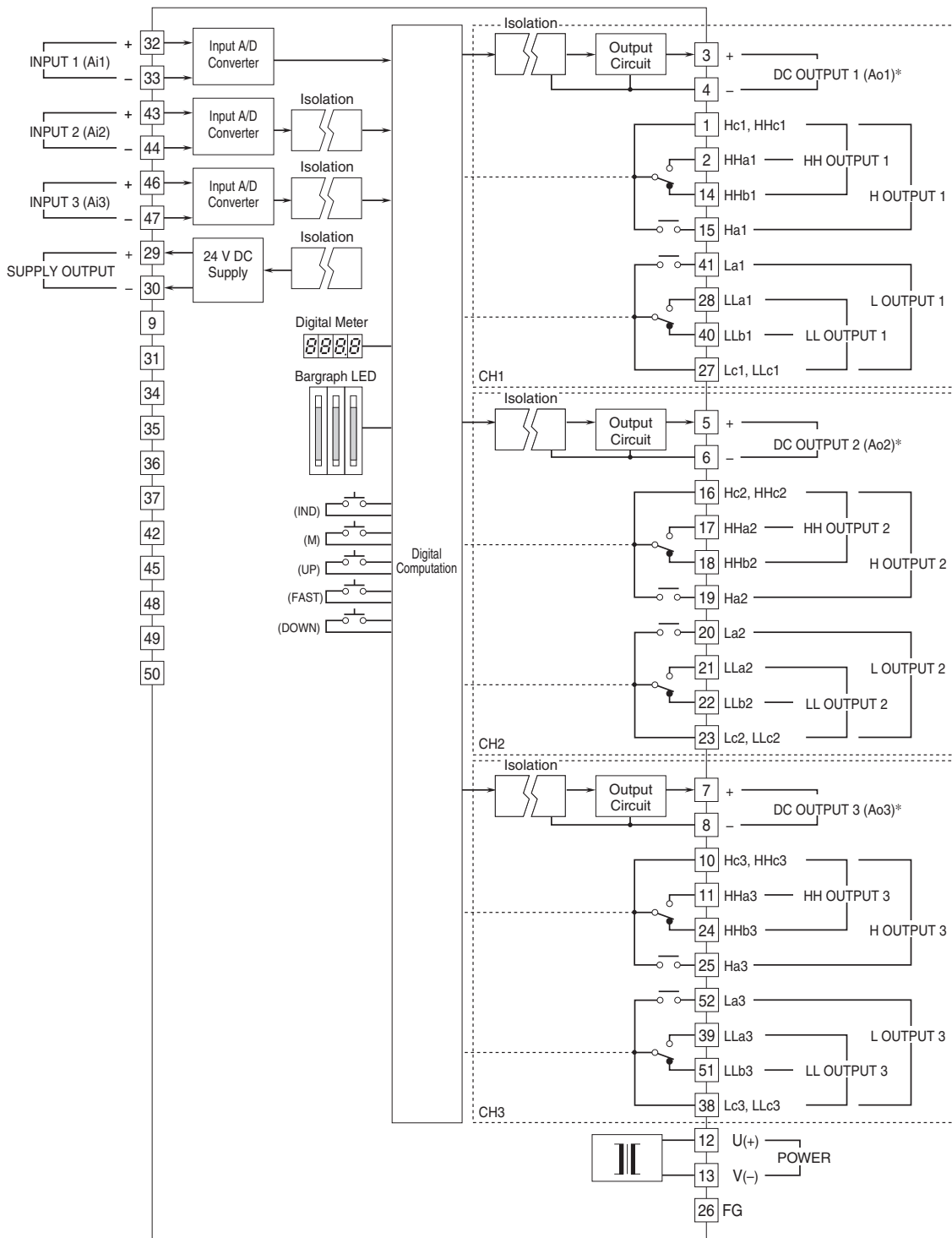

* Not available for output code /Y

CONNECTION (2-Wire transmitter)

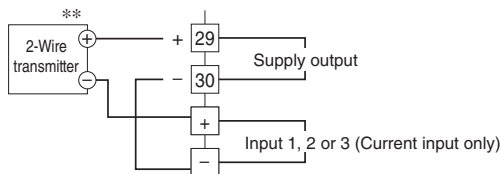

** Not applicable to smart transmitters



Specifications are subject to change without notice.