

Single Loop Controller Series

MULTI-FUNCTION PID CONTROLLER

(color LCD with touch-panel, MV output backup, Modbus/NestBus communication, expansion module function)

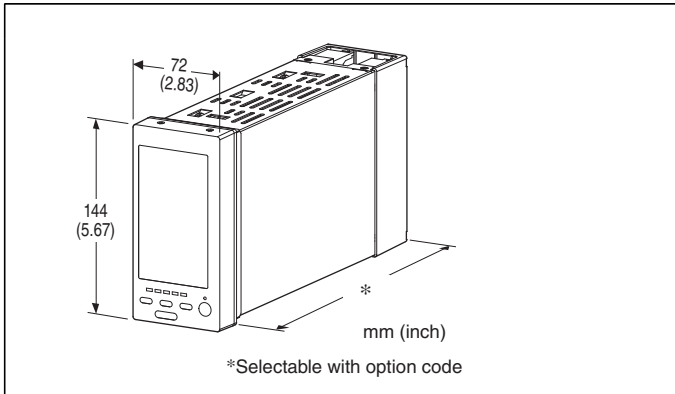

MODEL: SC210W-[1][2]-[3][4]

ORDERING INFORMATION

- Code number: SC210W-[1][2]-[3][4]
Specify a code from below for each of [1] through [4].
(e.g. SC210W-11-M2/3/M2/E/1/T/Q)
- Specify the specification for option code /Q
(e.g. /C01/S01)

[1] DISCRETE OUTPUT

- 1: Relay contact
- 2: Photo MOSFET relay

[2] MODBUS

- 1: Modbus-RTU
- 2: Modbus/TCP

[3] POWER INPUT

AC Power

M2: 100 - 240 V AC (Operational voltage range 85 - 264 V, 50/60 Hz)

DC Power

R: 24 V DC

(Operational voltage range 24 V \pm 10 %, ripple 10 %p-p max.)

[4] OPTIONS (multiple selections)

Housing Depth (must be specified)

- /3: 300 mm
- /4: 400 mm

Backup Module Power Supply

blank: Single supply

/M2: 100 - 240 V AC (dual supply)

(Operational voltage range 85 - 264 V AC; 50/60 Hz)

/R: 24 V DC (dual supply)

(Operational voltage range 24 V DC \pm 10 %; ripple 10 %p-p max.)

Control/Backup modules are powered from common terminals with 'single' supply type; powered from independent terminals with 'dual' supply type.

Language

blank: Japanese

/E: English

(Language (Japanese or English) can be chosen by front panel setting.)

Configurator Interface (must be specified)

/I: Stereo jack

Terminal block (must be specified)

/T: Separable terminal

Other Options

blank: none

/Q: Option other than the above (specify the specification)

SPECIFICATIONS OF OPTION: Q (multiple selections)

COATING (For the detail, refer to M-System's web site.)

/C01: Silicone coating

/C02: Polyurethane coating

/C03: Rubber coating

TERMINAL SCREW MATERIAL

/S01: Stainless steel

FUNCTIONS & FEATURES

Functions & Features

- Color LCD with touch panel
- Five Operation views (digital display, bargraph, dual-loop bargraph, short trend and user's parameter table views)
- Enhanced Engineering views (configuration, programming, tuning, and backup views)
- Universal input x 2 points, analog input x 4 points, discrete or pulse input x 6 points
- Current output (4-20 mA) x 2 points, voltage output (1-5 V) x 2 points, relay or photo-MOSFET relay output x 5 points
- RUN contact output (relay) x 1 point
- Expandable I/O points by connecting remote I/O modules via NestBus peer-to-peer communication
- Computation cycle selectable from 100 msec. to 3 sec. (control cycle selectable from 1 to 64 times of the computation cycle)
- Two PID function blocks
- Advanced computation and sequence control functions
- Auto-tuning function for automatically setting PID parameters
- Parameter input and change with touch panel

- Loop Configuration Builder Software (model: SFEW3E) for function parameter setting, list printing and data downloading/uploading
- PC Configurator Software (model: SCCFG) for exporting short trend data (CSV), and storing/transferring display parameter setting
- Control and supervision by SCADA software via Modbus TCP/IP or RTU communication
- Backup module (applicable to Mv2 only) is incorporated for manual loading: MV output is automatically switched to manual control in case of control module abnormality
- Independently powered and controlled backup module
- Easy extraction of control module at the front for replacement while MV output is maintained
- Housing with selectable depth enabling use of existing wires at replacement: 300 mm and 400 mm
- Separable terminal block
- Expansion of operations blocks due to Expansion module

Typical Applications

- Replacement of conventional controllers
- Panel operation for small-scale instrumentation

RELATED PRODUCTS

- PC Configurator cable (model: COP-US)
 - Loop configuration builder software (model: SFEW3E Ver. 1.101 or later)
 - PC configurator software (model: SCCFG Ver.1.84 or later)
- Builder software and configurator software are downloadable at M-System's web site.

ACCESSORIES

- Precision resistor module (model: REM4): 2 units
 - Cold junction compensation sensor: 2 pcs
 - Mounting brackets: 2 pcs
 - Connector adapter: 1 pce
- (The jack on the unit and the plug of PC Configurator cable (not included in the product) are different in size.)

GENERAL SPECIFICATIONS

Construction: Panel flush mounting

Degree of protection: IP55; ensured for the front panel of the unit independently mounted to a panel

Connection

Terminal screws: M3.5 screw terminals (torque 1.0 N·m)

Terminal fixing screws: M4 screw terminals (torque 1.2 N·m)

Backup module power supply terminal (option /M2, /R): Euro terminal block (wire dia. 2.4 max., 0.5 - 2.5 mm², stripped length 10 mm)

Ethernet: RJ-45 Modular Jack

Screw terminal

Terminal screws: Nickel-plated steel (standard) or stainless steel

Terminal fixing screws: Chrome-plated steel

Housing material: Flame-resistant resin (gray), steel

Isolation: Pv1 to Pv2 to supply output to Ai1 or Ai2 or Ai3 or Ai4 to Di1 or Di2 or Di3 or Di4 or Di5 or Pi1 or Pi2 or Pi3 or Pi4 or Pi5 to Di6 or Pi6 to Mv1 to Mv2 or Mv2B to Ao1 or Ao2 to Do1 to Do2 to Do3 to Do4 to Do5 to Do6 to NestBus to Modbus-RTU to Modbus/TCP to power to backup module power to FG

PID control: Single loop, cascade, advanced

Proportional band (P): 1 to 1000 %

Integral time (I): 0.01 to 100 minutes

Derivative time (D): 0.01 to 10 minutes

Auto-tuning: Limit cycle method

Alarm: PV high & low, deviation, rate of change

Computation: 48 functions blocks available for arithmetic operations, time functions, signal selection, limit, alarm and other functions

Sequence operation: Logic sequence and step sequence (max. 1068 commands)

Computation cycle: 100 msec. to 3 sec. (control cycle selectable among 1, 2, 4, 8, 16, 32 and 64 times of the computation cycle)

MV output range: -15 - +115 %

Parameter setting: With touch panel or PC (Loop Configuration Builder Software model: SFEW3E)

Self diagnostics: CPU monitoring with a watchdog timer

RUN contact: OFF in error detected by diagnostic (including NestBus)

Short trend

Storing interval: 1, 2, 5, 10, 20, 30 sec., 1, 2, 5, 10, 30, 60 min.

Capacity: 400 points (display 200 points)

■ Display

Display device: 4.3-inch TFT LCD

Display colors: 256

Resolution: 480 × 272 pixels

Pixel pitch: 0.198 × 0.198 mm (128 × 128 DPI)

Backlight: LED

Backlight life: Approx. 50 000 hours (at 50 % brightness)

Note: The backlight can be replaced in M-System factory. The LCD must be replaced at the same time.

Screen saver standby time: 1 to 99 minutes

Scaling range: -32000 to +32000

Decimal point position: 10⁻¹, 10⁻², 10⁻³, 10⁻⁴, 10⁻⁵ or none

Scale divisions: 2 to 10

Engineering unit indication: Max. 8 characters

Auto/Man indicator: Green/Amber LED

Backup mode MV output setting indicator: Blue LED

MV output setting indicator: Blue LED

FACTORY DEFAULT

■ LOOP 1

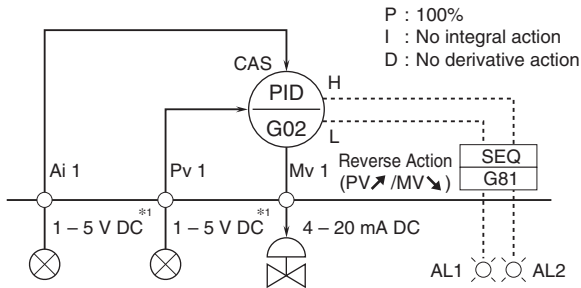

■ LOOP 2

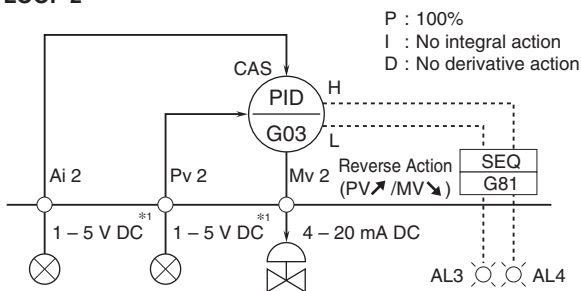

*1. Factory default setting
Use Loop Configuration Builder Software (model: SFEW3E)
to modify setting.

EXTERNAL INTERFACE

■ NestBus

Configuration: Bus type multi-drop
Standard: Conforms to TIA/EIA-485-A
Transfer rate: 19.2 kbps
Protocol: NestBus (M-System's own protocol)
Max. transmission distance: 1 kilometer
Transmission media:
Shielded twisted-pair cable (CPEV-S 0.9 dia.)
Terminating resistor: incorporated
Card No. setting: 0 - F (16 cards; 2 assigned for one unit)

■ Modbus-RTU

Configuration: Half-duplex, asynchronous, no procedure
Standard: Conforms to TIA/EIA-485-A
Max. transmission distance: 500 meters
Transfer rate: 4800, 9600, 19.2 k, 38.4 k bps
Data bit: 8
Parity bit: Odd, even, none
Max. node number: 15 (except the master)
Transmission media:
Shielded twisted-pair cable (CPEV-S 0.9 dia.)
Terminating resistor: incorporated
Node address setting: 1 - 247

■ Modbus/TCP (Ethernet)

Physical layer standard: IEEE 802.3u

Data link layer: 10BASE-T / 100BASE-TX
Transfer rate: 10 / 100 Mbps, Auto Negotiation

Protocol: Modbus/TCP

Data: RTU (binary)

Connections: 2

Transmission media:

10BASE-T (STP cable, category 5)

100BASE-TX (STP cable, category 5e)

Max. segment length: 100 meters

Port number: 502

IP address: 192.168.0.1 (factory setting)

SUPPLY OUTPUT

Output voltage:

24 V DC $\pm 10\%$ with no load

18 V DC min. at 20 mA

Current rating: ≤ 22 mA DC

• **Shortcircuit protection**

Current limited: Approx. 30 mA

INPUT SPECIFICATIONS

■ Pv1, Pv2 (universal input)

• **Current input:** 4 - 20 mA DC with input resistance 250 Ω (REM4)

• **Voltage input:** -10 - +10 V DC

-1 - +1 V DC

0 - 10 V DC

1 - 5 V DC

0 - 1 V DC

Input resistance: ≥ 1 M Ω

• **Thermocouple input:** K, E, J, T, B, R, S, C, N, U, L, P, PR (See Table 1)

Input resistance: ≥ 30 k Ω

Burnout sensing: ≤ 0.3 μ A

Burnout indication: 115 % of the measuring range (upscale)

• **RTD input:** Pt100 (JIS '97, IEC), Pt100 (JIS '89), JPt100 (JIS '89), Pt50 Ω (JIS '81), Ni100 (See Table 2)

Maximum lead wire resistance: 100 Ω per wire

Burnout indication: 115 % of the measuring range (upscale)

Sensing current: ≤ 1 mA

• **Potentiometer input:** Total resistance 100 Ω to 10 k Ω

Minimum span: 50 % of total resistance

Excitation: ≤ 0.6 V DC

■ Ai1, Ai2, Ai3, Ai4

• **Voltage input:** 1 - 5 V DC

Input resistance: ≥ 1 M Ω

■ **Pi1, Pi2, Pi3, Pi4, Pi5:** Dry contact

(Di1 through Di5 are assigned to the same terminals respectively.)

Maximum frequency: 20 Hz

Minimum pulse width: 25 msec.

Common: Negative common per 5 points

Sensing: Approx. 12 V DC, 6 mA

ON voltage/resistance: $\leq 2.25 \text{ V}$, $\leq 1.5 \text{ k}\Omega$

OFF voltage/resistance: $\geq 11.25 \text{ V}$ $\geq 15 \text{ k}\Omega$

■ **Pi6:** Dry contact

(Di6 is assigned to the same terminal.)

Maximum frequency: 10 kHz

Minimum pulse width: 0.05 msec.

Common: Negative common

Sensing: Approx. 12 V DC, 12 mA

ON voltage/resistance: $\leq 2 \text{ V}$, $\leq 1.5 \text{ k}\Omega$

OFF voltage/resistance: $\geq 11 \text{ V}$, $\geq 15 \text{ k}\Omega$

Excitation: 12 V DC $\pm 10\%$, 15 mA

Current limiting circuit: Approx. 30 mA

■ **Di1, Di2, Di3, Di4, Di5:** Dry contact

(Pi1 through Pi5 are assigned to the same terminals respectively.)

Common: Negative common per 5 points

Sensing: Approx. 12 V DC, 6 mA

ON voltage/resistance: $\leq 2.25 \text{ V}$, $\leq 1.5 \text{ k}\Omega$

OFF voltage/resistance: $\geq 11.25 \text{ V}$ $\geq 15 \text{ k}\Omega$

■ **Di6:** Dry contact

(Pi6 is assigned to the same terminal.)

Common: Negative common

Sensing: Approx. 12 V DC, 12 mA

ON voltage/resistance: $\leq 2 \text{ V}$, $\leq 1.5 \text{ k}\Omega$

OFF voltage/resistance: $\geq 11 \text{ V}$, $\geq 15 \text{ k}\Omega$

[Table 1 (Thermocouple input)]

T/C	USABLE RANGE (°C)	CONFORMANCE RANGE (°C)
K (CA)	-272 to +1472	-150 to +1370
E (CRC)	-272 to +1100	-170 to +1000
J (IC)	-260 to +1300	-180 to +1200
T (CC)	-272 to +500	-170 to +400
B (RH)	24 to 1920	1000 to 1760
R	-100 to +1860	380 to 1760
S	-100 to +1860	400 to 1760
C (WRe 5-26)	-52 to +2416	100 to 2315
N	-272 to +1400	-130 to +1300
U	-252 to +700	-200 to +600
L	-252 to +1000	-200 to +900
P (Platinel II)	-52 to +1496	0 to 1395
(PR)	-52 to +1860	300 to 1760

Overrange input (out of the usable range) is handled as burnout.

[Table 2 (RTD input)]

RTD	USABLE RANGE (°C)	CONFORMANCE RANGE (°C)
Pt 100 (JIS '97, IEC)	-240 to +900	-200 to +850
Pt 100 (JIS '89)	-240 to +900	-200 to +660
JPt 100 (JIS '89)	-236 to +560	-200 to +510
Pt 50 Ω (JIS '81)	-236 to +700	-200 to +649
Ni 100	-100 to +252	-80 to +250

Overrange input (out of the usable range) is handled as burnout.

OUTPUT SPECIFICATIONS

■ **Mv1, Mv2, Mv2B**

• **Current output:** 4 - 20 mA DC

Load resistance: $\leq 600 \Omega$

(Mv2B is the output from backup unit.)

■ **Ao1, Ao2**

• **Voltage output:** 1 - 5 V DC

Load resistance: $\geq 10 \text{ k}\Omega$

■ **Discrete Output**

• **Do1, Do2, Do3, Do4, Do5, RUN contact (Do6):** Relay contact

Rated load: 250 V AC @1 A ($\cos \phi = 1$)

30 V DC @1 A (resistive load)

Maximum switching voltage: 250 V AC or 30 V DC

Maximum switching power: 250 VA or 60 W

Minimum load: 5 V DC @10 mA

Mechanical life: 2×10^7 cycles

• **Do1, Do2, Do3, Do4, Do5:** Photo MOSFET relay

Rating: 200 V AC/DC @0.5 A (resistive load)

ON resistance: 2.1 Ω

Maximum frequency: 4 Hz @24 V, 10 mA

ON delay time: ≤ 5.0 msec.

OFF delay time: ≤ 3.0 msec.

INSTALLATION

Power input

• **AC:**

Control module

$\leq 25 \text{ VA}$ at 100 V AC

$\leq 40 \text{ VA}$ at 240 V AC

Backup module

$\leq 10 \text{ VA}$ at 100 V AC

$\leq 15 \text{ VA}$ at 240 V AC

• **DC**

Control module: $\leq 650 \text{ mA}$

Backup module: $\leq 150 \text{ mA}$

Operating temperature: -5 to +55°C (23 to 131°F)

Operating humidity: 5 to 90 %RH (non-condensing)

Mounting: Panel flush mounting (high-density mounting in horizontal direction)

Weight:

Approx. 2.0 kg (4.41 lb) for 300 mm depth type

Approx. 2.5 kg (5.51 lb) for 400 mm depth type

PERFORMANCE

Accuracy

DC input: $\pm 0.1 \%$ ± 1 digit

Thermocouple input: $\pm 1^\circ\text{C}$ ± 1 digit

$\pm 2^\circ\text{C}$ ± 1 digit for B, R, S, C and PR

RTD input: $\pm 1^\circ\text{C}$ ± 1 digit

Potentiometer input: $\pm 0.2 \%$ ± 1 digit

DC output: $\pm 0.1 \%$

Precision resistor module (REM4): $\pm 0.1 \%$

Cold junction compensation:

$\pm 2^\circ\text{C}$ at $25^\circ\text{C} \pm 10^\circ\text{C}$

$\pm 4^\circ\text{C}$ for S, R and PR

Temp. coefficient: $\pm 0.015 \%/^\circ\text{C}$ ($\pm 0.008 \%/^\circ\text{F}$)

DC input: $\pm 0.015 \%/^\circ\text{C}$ ($\pm 0.008 \%/^\circ\text{F}$)

Thermocouple input: $\pm 0.015 \%/^\circ\text{C}$ ($\pm 0.008 \%/^\circ\text{F}$)

RTD input: $\pm 0.015 \%/^\circ\text{C}$ ($\pm 0.008 \%/^\circ\text{F}$)

Potentiometer input: $\pm 0.015 \%/^\circ\text{C}$ ($\pm 0.008 \%/^\circ\text{F}$)

DC output: $\pm 0.015 \%/^\circ\text{C}$ ($\pm 0.008 \%/^\circ\text{F}$)

Precision resistor module (REM4): $\pm 0.015 \%/^\circ\text{C}$ ($\pm 0.008 \%/^\circ\text{F}$)

Line voltage effect: $\pm 0.1 \%$ over voltage range

Calendar clock accuracy: Monthly deviation 3 minutes at 25°C

RAM memory duration in power failure for hot start:

10 minutes assured

Insulation resistance: $\geq 100 \text{ M}\Omega$ with 500 V DC

Dielectric strength:

1500 V AC @ 1 minute

(Pv1 or supply output to Pv2 or Ai1 or Ai2 or Ai3 or Ai4 to Di1 or Di2 or Di3 or Di4 or Di5 or Pi1 or Pi2 or Pi3 or Pi4 or Pi5 to Di6 or Pi6 to Mv1 to Mv2 or Mv2B or Ao1 or Ao2 to Do1 to Do2 or Do3 or Do4 or Do5 or Do6 to NestBus to Modbus-RTU to Modbus/TCP to power to backup module power to FG)

500 V AC @ 1 minute (Pv2 to Ai1 or Ai2 or Ai3 or Ai4)

500 V AC @ 1 minute (Mv2 or Mv2B to Ao1 or Ao2)

500 V AC @ 1 minute (Do2 to Do3 to Do4 to Do5 to Do6)

500 V AC @ 1 minute (Pv1 to supply output)

EXTERNAL VIEW

■ CONTROL MODULE FRONT VIEW

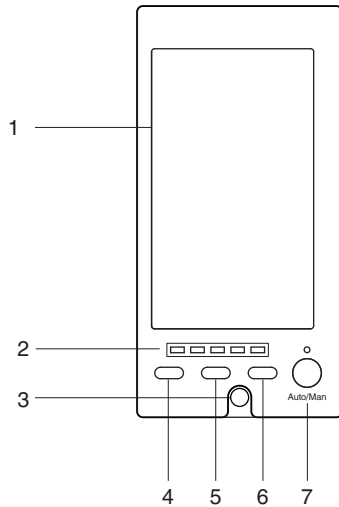

1. TFT Color LCD with touch panel
Provides operation and engineering views to facilitate monitoring and setting
2. MV output setting indicator LEDs for the backup mode
3. Configurator jack and cap
Connects with a PC where Loop Configuration Builder Software (model: SFEW3E) or PC configurator software (model: SCCFG) is installed via a PC configurator cable (model: COP-US) and enables programming and parameter setting
4. MV value (DOWN) button
5. Acceleration button
(Accelerates MV signal's changing speed by pressing simultaneously with MV value button)
6. MV value (UP) button
7. Auto / Man selector (changes the control mode for MV output)

■ BACKUP MODULE

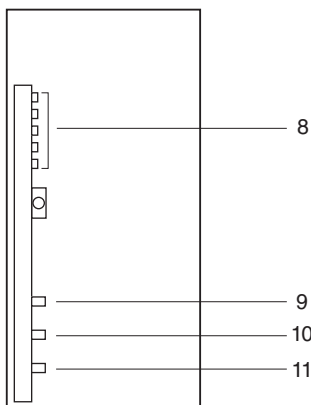

8. MV output setting indicators
9. MV value (UP) button
10. Acceleration button
(Accelerates MV signal's changing speed by pressing simultaneously with MV value button)
11. MV value (DOWN) button

COMMUNICATION CABLE CONNECTIONS

■ NestBus

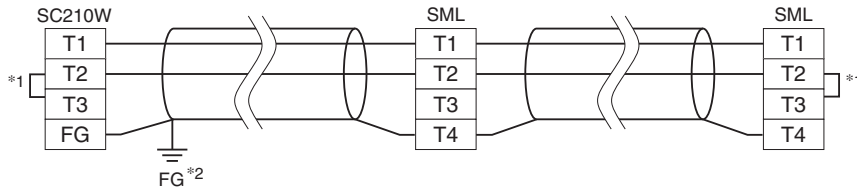

■ Modbus-RTU

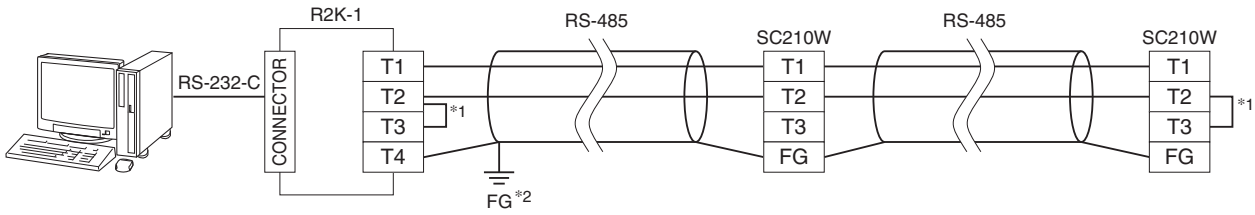

- *1. Internal terminating resistor is used when the device is at the end of a transmission line.
- *2. For noise protection, connect all shielded cables with each other and ground them at a single dedicated ground point within the system with grounding resistance of 100 Ω or less. Note that the most suitable ground point differs depending on the system. Also note that there may be cases where less noise is caused when the shields are left ungrounded.

EXTERNAL DIMENSIONS & TERMINAL ASSIGNMENTS unit: mm (inch)

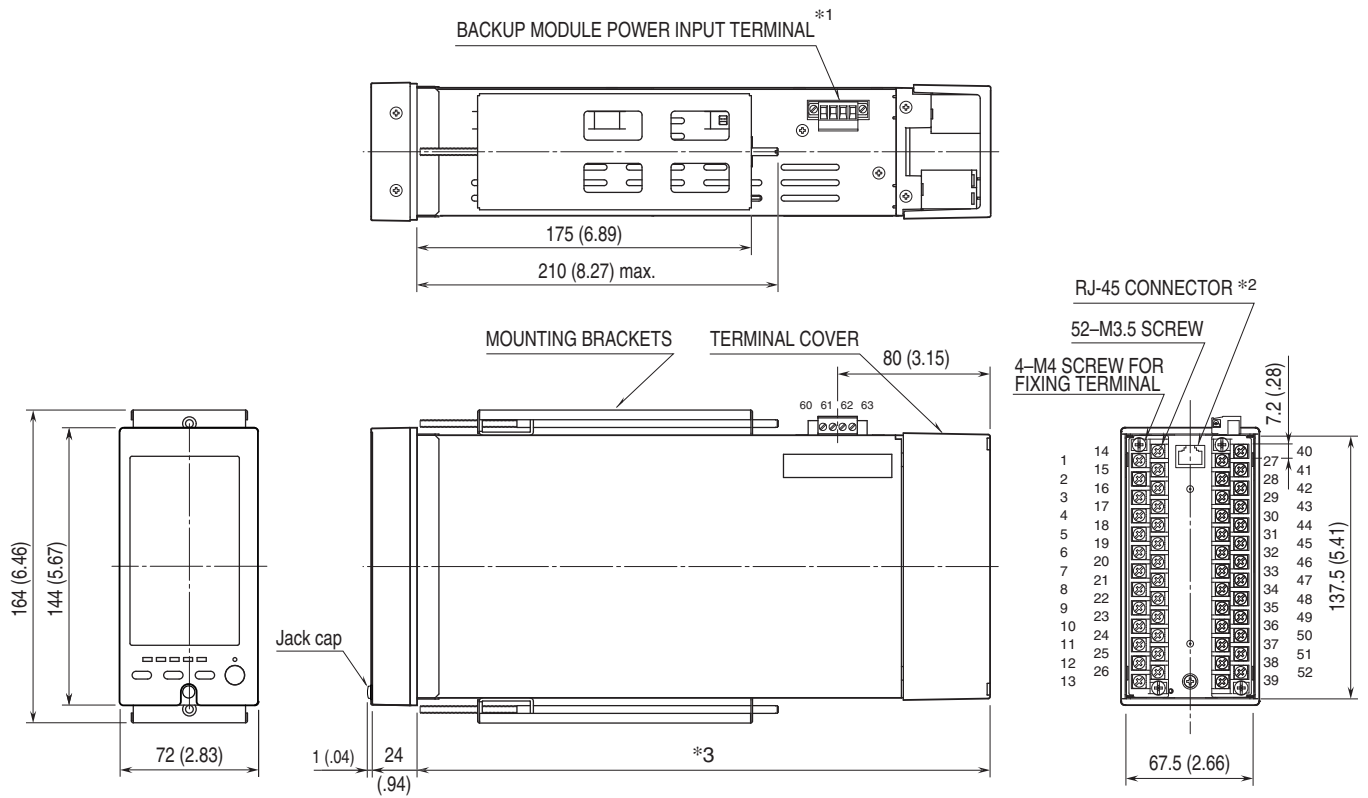

*1. Option /M2, /R only
 *2. For Modbus/TCP only

*3. Option /3: 300 mm (11.81")
 Option /4: 400 mm (15.75")

MOUNTING REQUIREMENTS unit: mm

■ PANEL CUTOUT unit: mm

• Single mounting

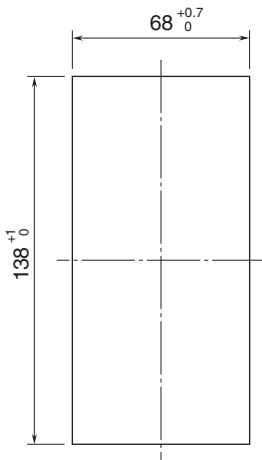

• Clustered mounting

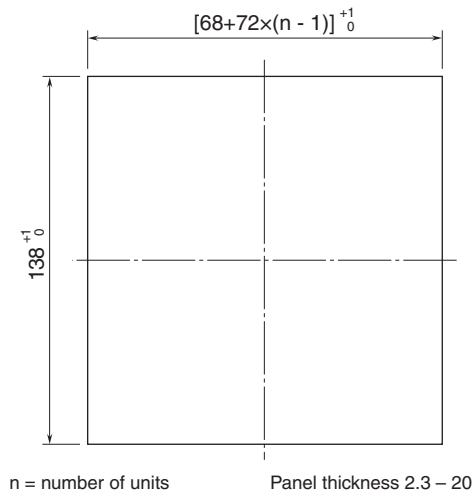

■ Caution

- IP55 is ensured for the front panel of the unit independently mounted to a panel. Securely seal the mounting surface along the panel cutout once the unit is installed.
- Set the unit on a vertical surface with its operation buttons at the lower side. Mounting in other directions may cause heat built up inside the unit and shorten its life span or degrade its performance.
- Ensure that there is sufficient space for ventilation inside the panel. Do not install above the devices that generate high heat such as heaters, transformers or resistors. Leave at least 30 mm (1.2 inch) space above, below and behind the unit for maintenance purpose (e.g. wiring, removing or installing).

SCHEMATIC CIRCUITRY & CONNECTION DIAGRAM

■ BACKUP MODULE POWER SUPPLY: SINGLE SUPPLY

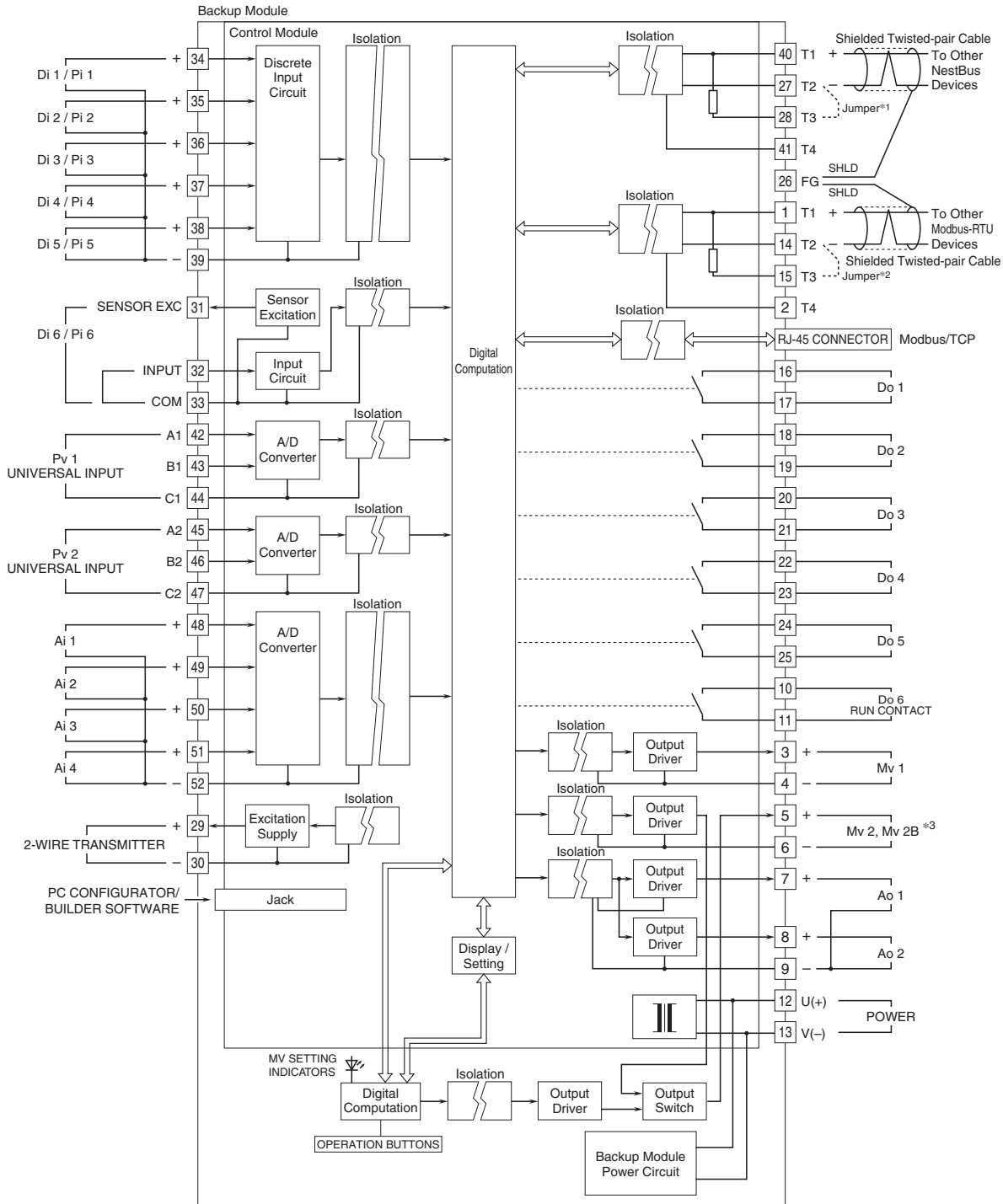

- *1. Close across the terminals 27 – 28 when the unit is located at the end of a transmission line (= no cross-wiring).
- *2. Close across the terminals 14 – 15 when the unit is located at the end of a transmission line (= no cross-wiring).
- *3. Backup is applicable to Mv 2 only. Mv 2B is output of the backup module.

■ UNIVERSAL INPUT CONNECTION E.G.

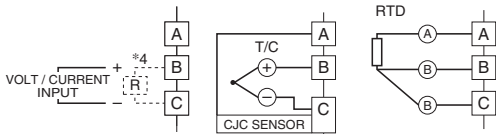

- *4. Connect input resistor module (model: REM4) for current input.
- *5. Connect C/JC sensor for thermocouple input.
- *6. Connect input resistor module (model: REM4).

■ DISCRETE INPUT PULSE INPUT CONNECTION E.G.:

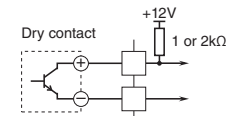

■ BACKUP MODULE POWER SUPPLY: DUAL SUPPLY

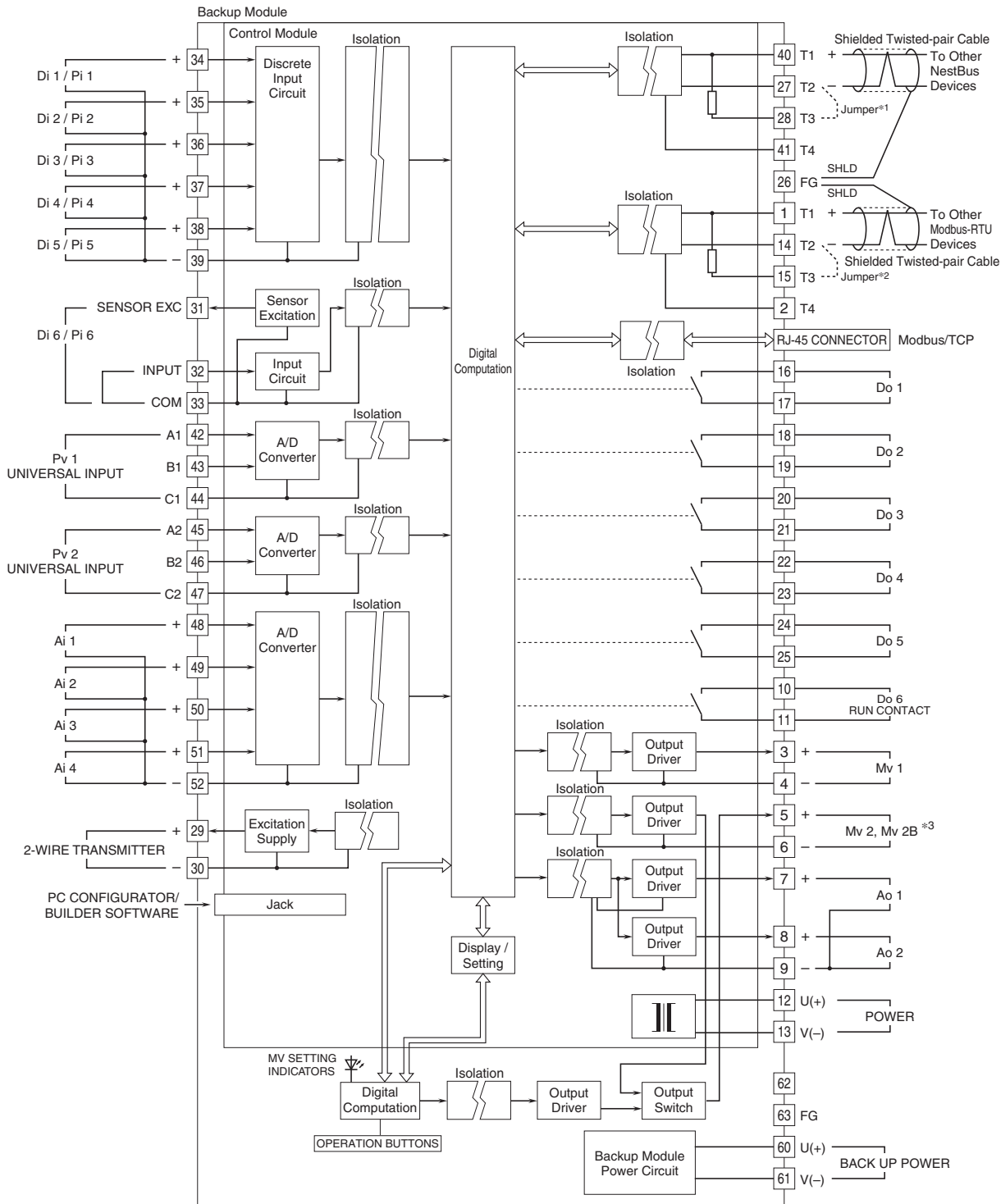

- *1. Close across the terminals 27 – 28 when the unit is located at the end of a transmission line (= no cross-wiring).
- *2. Close across the terminals 14 – 15 when the unit is located at the end of a transmission line (= no cross-wiring).
- *3. Backup is applicable to Mv 2 only. Mv 2B is output of the backup module.

■ UNIVERSAL INPUT CONNECTION E.G.

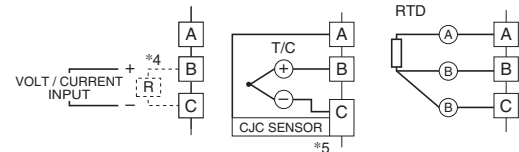

- *4. Connect input resistor module (model: REM4) for current input.
- *5. Connect C/J sensor for thermocouple input.
- *6. Connect input resistor module (model: REM4).

■ DISCRETE INPUT PULSE INPUT CONNECTION E.G.:

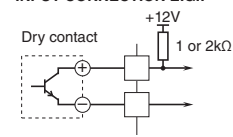

SYSTEM CONFIGURATION EXAMPLES

■ SINGLE LOOP CONTROL

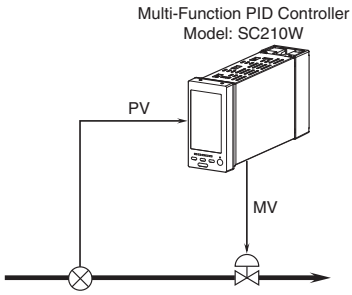

■ CASCADE CONTROL

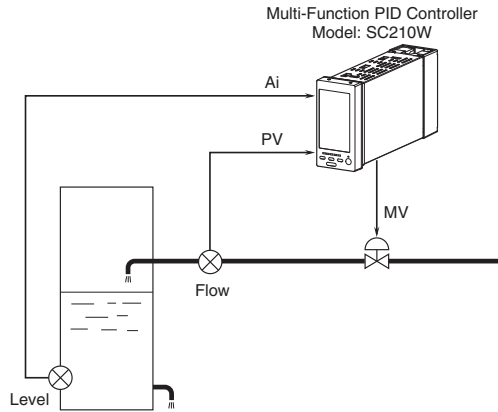

■ I/O EXPANDED VIA NESTBUS

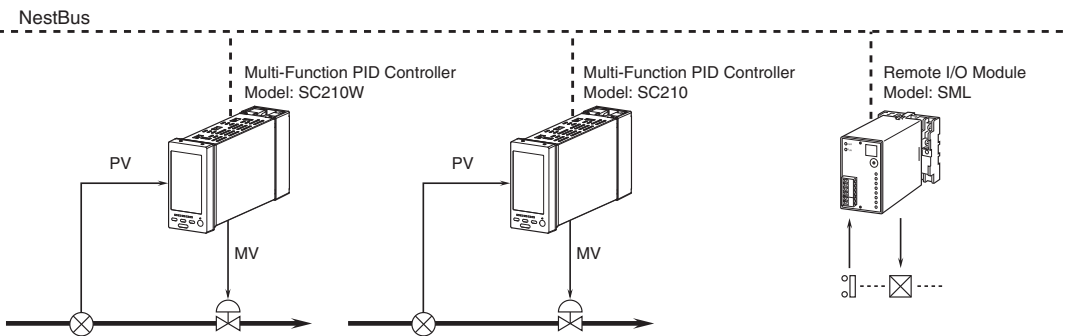

■ CONTROL / SUPERVISION VIA MODBUS/TCP

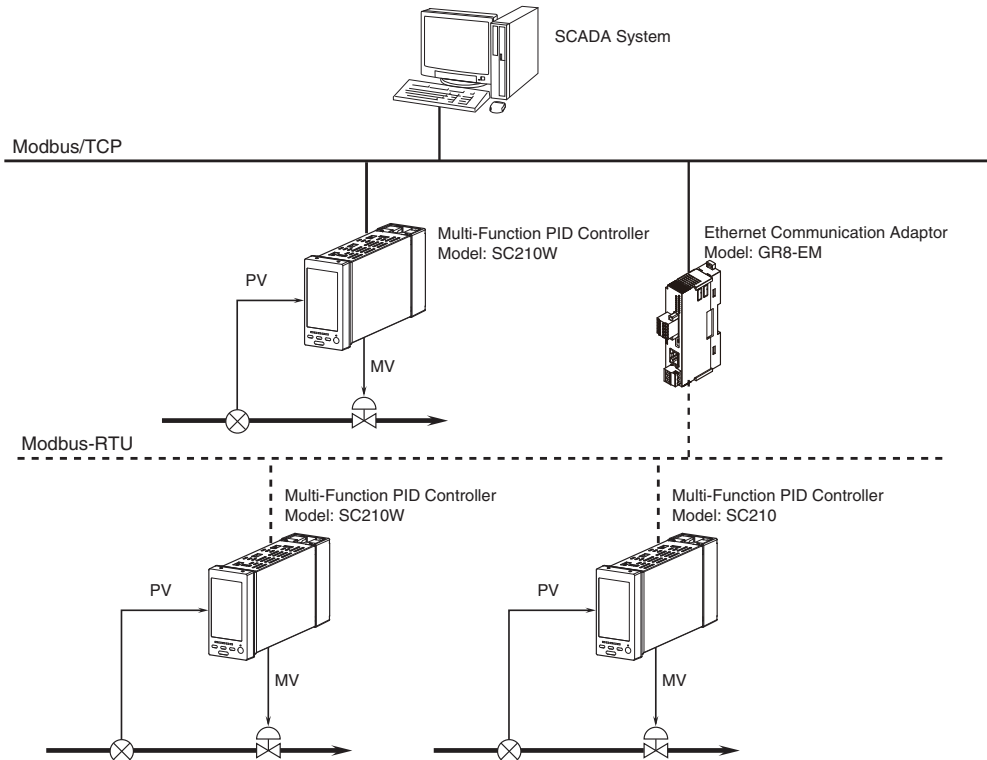

■ CONTROL / SUPERVISION VIA MODBUS-RTU

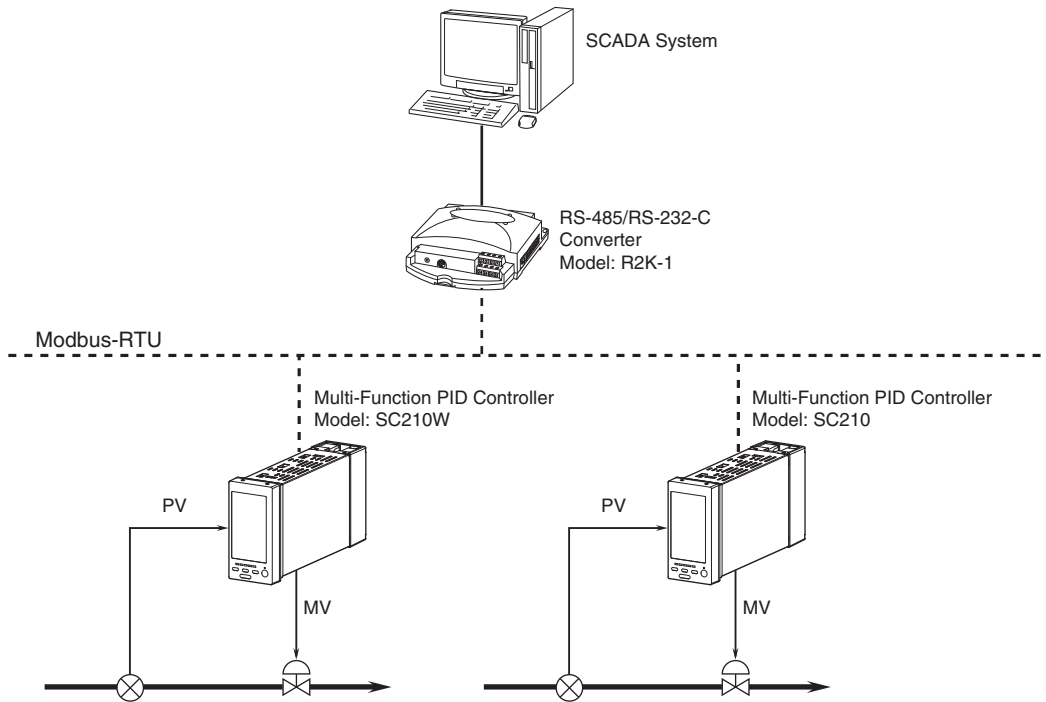

Specifications are subject to change without notice.