

## Single Loop Controller Series

### MULTI-FUNCTION PID CONTROLLER

(color LCD with touch-panel, Modbus/NestBus communication)

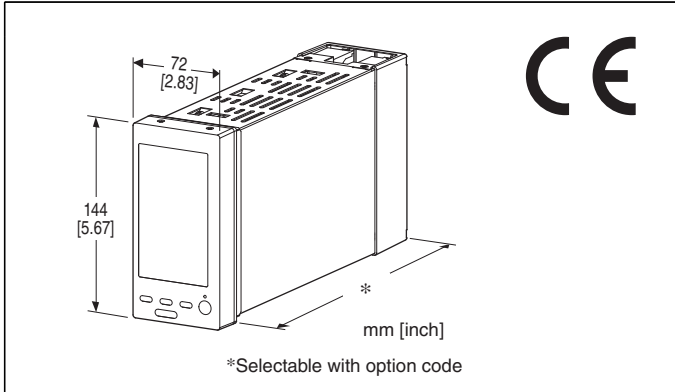

### MODEL: SC200-[1][2]-[3][4]

#### ORDERING INFORMATION

- Code number: SC200-[1][2]-[3][4]
- Specify a code from below for each of [1] through [4].  
(e.g. SC200-11-M2/3/E/1/T/Q)
- Specify the specification for option code /Q  
(e.g. /C01/S01)

#### [1] DISCRETE OUTPUT

- 1: Relay contact
- 2: Photo MOSFET relay

#### [2] MODBUS

- 1: Modbus-RTU
- 2: Modbus/TCP

#### [3] POWER INPUT

##### AC Power

M2: 100 - 240 V AC (Operational voltage range 85 - 264 V, 50/60 Hz)

##### DC Power

R: 24 V DC

(Operational voltage range 24 V ±10 %, ripple 10 %p-p max.)

#### [4] OPTIONS (multiple selections)

##### Housing Depth

blank: 250 mm

/300: 300 mm (Discontinued, select /3)

/400: 400 mm (Discontinued, select /4)

/3: 300 mm

/4: 400 mm

#### Language

blank: Japanese

/E: English

(Language (Japanese or English) can be chosen by front panel setting.)

#### Configurator Interface

blank: Infrared

/I: Stereo jack

(If external noise interference is a concern, stereo jack type is recommended.)

#### Terminal block

blank: One block terminal

/T: Separable terminal

#### Other Options

blank: none

/Q: Option other than the above (specify the specification)

#### SPECIFICATIONS OF OPTION: Q (multiple selections)

##### COATING (For the detail, refer to M-System's web site.)

/C01: Silicone coating

/C02: Polyurethane coating

/C03: Rubber coating

##### TERMINAL SCREW MATERIAL

/S01: Stainless steel

#### FUNCTIONS & FEATURES

##### Functions & Features

- Color LCD with touch panel
- Five Operation views (digital display, bargraph, dual-loop bargraph, short trend and user's parameter table views)
- Enhanced screen functions for engineering (configuration, programming and tuning views)
- Universal input x 2 points, analog input x 4 points, discrete input x 6 points, pulse input x 5 points, high speed pulse input x 1 point
- Current output (4-20 mA) x 2 points, voltage output (1-5 V) x 2 points, relay or photo-MOSFET relay output x 5 points
- RUN contact output (relay) x 1 point
- I/O signals can be added with remote I/O modules connected via NestBus peer-to-peer communication
- Computation cycle selectable between 50 msec. and 3 sec. (control cycle selectable between 1 and 64 times of the computation cycle)
- Two PID function blocks
- Advanced computation and sequence control functions
- Auto-tuning function
- Parameter input and changing with touch panel
- Function parameter setting, list printing and data downloading/uploading available with Loop Configuration Builder Software (model: SFEW3E)
- Short trend export (CSV), display parameter setting,

saving and transfer with PC Configurator Software (model: SCCFG)

- Control and supervision by SCADA software via Modbus TCP/IP or RTU communication
- Selectable housing depth for ease of using existing wires in replacement: 250 mm, 300 mm and 400 mm
- Separable terminal block

### Typical Applications

- Replacement of conventional controllers
- Panel operation for small-scale instrumentation

## RELATED PRODUCTS

- PC Configurator cable (model: COP-US)
  - Loop configuration builder software (model: SFEW3E Ver. 1.40 or later)
  - Infrared communication adaptor (model: COP-IRDA)
  - PC configurator software (model: SCCFG Ver.1.50 or later)
- Builder software and configurator software are downloadable at M-System's web site.

## ACCESSORIES

- Precision resistor module (model: REM4): 2
  - Cold junction sensor: 2
  - Mounting brackets: 2
  - Connector adapter: 1
- (included in Stereo jack type. The jack on the unit and the plug of PC Configurator cable (not included in the product) are different in size.)

## GENERAL SPECIFICATIONS

**Construction:** Panel flush mounting

**Degree of protection:** IP55; ensured for the front panel of the unit independently mounted to a panel

### Connection

**Terminal screws:** M3.5 screw terminals (torque 1.0 N·m)

**Terminal fixing screws:** M4 screw terminals (torque 1.2 N·m)

**Ethernet:** RJ-45 Modular Jack

### Screw terminal

**Terminal screws:** Nickel-plated steel (standard) or stainless steel

**Terminal fixing screws:** Chrome-plated steel

**Housing material:** Flame-resistant resin (gray), steel

**Isolation:** Pv1 to Pv2 to supply output to Ai1 or Ai2 or Ai3 or Ai4 to Di1 or Di2 or Di3 or Di4 or Di5 or Pi1 or Pi2 or Pi3 or Pi4 or Pi5 to Di6 or Pi6 to Mv1 to Mv2 to Ao1 or Ao2 to Do1 to Do2 to Do3 to Do4 to Do5 to Do6 to NestBus to Modbus-RTU to Modbus/TCP to power to FG

**PID control:** Single loop, cascade, advanced

**Proportional band (P):** 1 to 1000 %

**Integral time (I):** 0.01 to 100 minutes

**Derivative time (D):** 0.01 to 10 minutes

**Auto-tuning:** Limit cycle method

**Alarm:** PV high & low, deviation, rate of change

**Computation:** 48 functions blocks available for arithmetic operations, time functions, signal selection, limit, alarm and other functions

**Sequence operation:** Logic sequence and step sequence (max. 1068 commands)

**Computation cycle:** 50 msec. to 3 sec. (control cycle selectable among 1, 2, 4, 8, 16, 32 and 64 times of the computation cycle)

**MV output range:** -15 - +115 %

**Parameter setting:** With touch panel or PC (Loop Configuration Builder Software model: SFEW3E)

**Self diagnostics:** CPU monitoring with a watchdog timer

**RUN contact:** OFF in error detected by diagnostic (including NestBus)

**Infrared communication:** Transmission distance max. 0.2 meter (for use with the COP-IRDA)

### Short trend

**Storing interval:** 1, 2, 5, 10, 20, 30 sec.,  
1, 2, 5, 10, 30, 60 min.

**Capacity:** 400 points (display 200 points)

### ■ Display

**Display device:** 4.3-inch TFT LCD

**Display colors:** 256

**Resolution:** 480 × 272 pixels

**Pixel pitch:** 0.198 × 0.198 mm (128 × 128 DPI)

**Backlight:** LED

**Backlight life:** Approx. 50 000 hours (at 50 % brightness)

Note: The backlight can be replaced in M-System factory. The LCD must be replaced at the same time.

**Screen saver standby time:** 1 to 99 minutes

**Scaling range:** -32000 to +32000

**Decimal point position:** 10<sup>-1</sup>, 10<sup>-2</sup>, 10<sup>-3</sup>, 10<sup>-4</sup>, 10<sup>-5</sup> or none

**Scale divisions:** 2 to 10

**Engineering unit indication:** Max. 8 characters

**Auto/Man indicator:** Green/Amber LED

## FACTORY DEFAULT

### ■ LOOP 1

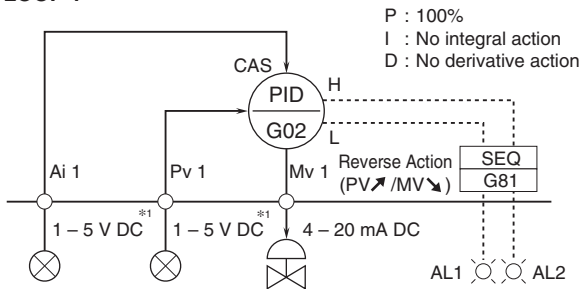

### ■ LOOP 2

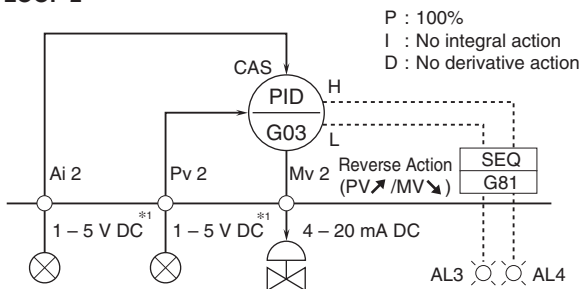

\*1. Factory default setting  
Use Loop Configuration Builder Software (model: SFEW3E)  
to modify setting.

## EXTERNAL INTERFACE

### ■ NestBus

**Configuration:** Bus type multi-drop  
**Standard:** Conforms to TIA/EIA-485-A  
**Transfer rate:** 19.2 kbps  
**Protocol:** NestBus (M-System's own protocol)  
**Max. transmission distance:** 1 kilometer  
**Transmission media:**  
Shielded twisted-pair cable (CPEV-S 0.9 dia.)  
**Terminating resistor:** incorporated  
**Address setting:** 0 - F (16 nodes)

### ■ Modbus-RTU

**Configuration:** Half-duplex, asynchronous, no procedure  
**Standard:** Conforms to TIA/EIA-485-A  
**Max. transmission distance:** 500 meters  
**Transfer rate:** 4800, 9600, 19.2 k, 38.4 k bps  
**Data bit:** 8  
**Parity bit:** Odd, even, none  
**Max. node number:** 15 (except the master)  
**Transmission media:**  
Shielded twisted-pair cable (CPEV-S 0.9 dia.)  
**Terminating resistor:** incorporated  
**Node address setting:** 1 - 247

### ■ Modbus/TCP (Ethernet)

**Physical layer standard:** IEEE 802.3u  
**Data link layer:** 10BASE-T / 100BASE-TX  
**Transfer rate:** 10 / 100 Mbps, Auto Negotiation

**Protocol:** Modbus/TCP

**Data:** RTU (binary)

**Connections:** 2

**Transmission media:**

10BASE-T (STP cable, category 5)

100BASE-TX (STP cable, category 5e)

**Max. segment length:** 100 meters

**Port number:** 502

**IP address:** 192.168.0.1 (factory setting)

## SUPPLY OUTPUT

**Output voltage:**

24 V DC  $\pm 10\%$  with no load

18 V DC min. at 20 mA

**Current rating:**  $\leq 22$  mA DC

•Shortcircuit protection

**Current limited:** Approx. 30 mA

## INPUT SPECIFICATIONS

### ■ Pv1, Pv2 (universal input)

•**Current input:** 4 - 20 mA DC with input resistance 250  $\Omega$  (REM4)

•**Voltage input:** -10 - +10 V DC

-1 - +1 V DC

0 - 10 V DC

1 - 5 V DC

0 - 1 V DC

**Input resistance:**  $\geq 1$  M $\Omega$

•**Thermocouple input:** K, E, J, T, B, R, S, C, N, U, L, P, PR (See Table 1)

**Input resistance:**  $\geq 30$  k $\Omega$

**Burnout sensing:**  $\leq 0.3$   $\mu$ A

**Burnout indication:** 115 % of the measuring range (upscale)

•**RTD input:** Pt100 (JIS '97, IEC), Pt100 (JIS '89), JPt100 (JIS '89), Pt50 $\Omega$  (JIS '81), Ni100 (See Table 2)

**Maximum lead wire resistance:** 100  $\Omega$  per wire

**Burnout indication:** 115 % of the measuring range (upscale)

**Sensing current:**  $\leq 1$  mA

•**Potentiometer input:** Total resistance 100  $\Omega$  to 10 k $\Omega$

**Minimum span:** 50 % of total resistance

**Excitation:**  $\leq 0.6$  V DC

### ■ Ai1, Ai2, Ai3, Ai4

•**Voltage input:** 1 - 5 V DC

**Input resistance:**  $\geq 1$  M $\Omega$

■ **Pi1, Pi2, Pi3, Pi4, Pi5:** Dry contact

(Di1 through Di5 are assigned to the same terminals respectively.)

**Maximum frequency:** 20 Hz

**Minimum pulse width:** 25 msec.

**Common:** Negative common per 5 points

**Sensing:** Approx. 12 V DC, 6 mA

**ON voltage/resistance:**  $\leq 2.25 \text{ V}$ ,  $\leq 1.5 \text{ k}\Omega$

**OFF voltage/resistance:**  $\geq 11.25 \text{ V}$   $\geq 15 \text{ k}\Omega$

■ **PI6:** Dry contact

(Di6 is assigned to the same terminal.)

**Maximum frequency:** 10 kHz

**Minimum pulse width:** 0.05 msec.

**Common:** Negative common

**Sensing:** Approx. 12 V DC, 12 mA

**ON voltage/resistance:**  $\leq 2 \text{ V}$ ,  $\leq 1.5 \text{ k}\Omega$

**OFF voltage/resistance:**  $\geq 11 \text{ V}$ ,  $\geq 15 \text{ k}\Omega$

**Excitation:** 12 V DC  $\pm 10\%$ , 15 mA

**Current limiting circuit:** Approx. 30 mA

■ **Di1, Di2, Di3, Di4, Di5:** Dry contact

(Pi1 through Pi5 are assigned to the same terminals respectively.)

**Common:** Negative common per 5 points

**Sensing:** Approx. 12 V DC, 6 mA

**ON voltage/resistance:**  $\leq 2.25 \text{ V}$ ,  $\leq 1.5 \text{ k}\Omega$

**OFF voltage/resistance:**  $\geq 11.25 \text{ V}$   $\geq 15 \text{ k}\Omega$

■ **Di6:** Dry contact

(Pi6 is assigned to the same terminal.)

**Common:** Negative common

**Sensing:** Approx. 12 V DC, 12 mA

**ON voltage/resistance:**  $\leq 2 \text{ V}$ ,  $\leq 1.5 \text{ k}\Omega$

**OFF voltage/resistance:**  $\geq 11 \text{ V}$ ,  $\geq 15 \text{ k}\Omega$

**[Table 1 (Thermocouple input)]**

T/C	USABLE RANGE (°C)	CONFORMANCE RANGE (°C)
K (CA)	-272 to +1472	-150 to +1370
E (CRC)	-272 to +1100	-170 to +1000
J (IC)	-260 to +1300	-180 to +1200
T (CC)	-272 to +500	-170 to +400
B (RH)	24 to 1920	1000 to 1760
R	-100 to +1860	380 to 1760
S	-100 to +1860	400 to 1760
C (WRe 5-26)	-52 to +2416	100 to 2315
N	-272 to +1400	-130 to +1300
U	-252 to +700	-200 to +600
L	-252 to +1000	-200 to +900
P (Platinel II)	-52 to +1496	0 to 1395
(PR)	-52 to +1860	300 to 1760

Overrange input (out of the usable range) is handled as burnout.

**[Table 2 (RTD input)]**

RTD	USABLE RANGE (°C)	CONFORMANCE RANGE (°C)
Pt 100 (JIS '97, IEC)	-240 to +900	-200 to +850
Pt 100 (JIS '89)	-240 to +900	-200 to +660
JPt 100 (JIS '89)	-236 to +560	-200 to +510
Pt 50 $\Omega$ (JIS '81)	-236 to +700	-200 to +649
Ni 100	-100 to +252	-80 to +250

Overrange input (out of the usable range) is handled as burnout.

## OUTPUT SPECIFICATIONS

■ **Mv1, Mv2**

• **Current output:** 4 - 20 mA DC

**Load resistance:**  $\leq 600 \Omega$

■ **Ao1, Ao2**

• **Voltage output:** 1 - 5 V DC

**Load resistance:**  $\geq 10 \text{ k}\Omega$

■ **Discrete Output**

• **Do1, Do2, Do3, Do4, Do5, RUN contact (Do6):** Relay contact

**Rated load:** 250 V AC @1 A ( $\cos \phi = 1$ )

30 V DC @1 A (resistive load)

**Maximum switching voltage:** 250 V AC or 30 V DC

**Maximum switching power:** 250 VA or 60 W

**Minimum load:** 5 V DC @10 mA

**Mechanical life:**  $2 \times 10^7$  cycles

• **Do1, Do2, Do3, Do4, Do5:** Photo MOSFET relay

**Rating:** 200 V AC/DC @0.5 A (resistive load)

**ON resistance:** 2.1  $\Omega$

**Maximum frequency:** 4 Hz @24 V, 10 mA

**ON delay time:**  $\leq 5.0$  msec.

**OFF delay time:**  $\leq 3.0$  msec.

## INSTALLATION

**Power input**

• **AC:**

$\leq 25 \text{ VA}$  at 100 V AC

$\leq 40 \text{ VA}$  at 240 V AC

• **DC:**  $\leq 650 \text{ mA}$

**Operating temperature:** -5 to +55°C (23 to 131°F)

**Operating humidity:** 5 to 90 %RH (non-condensing)

**Mounting:** Panel flush mounting (high-density mounting in horizontal direction)

**Weight:**

Approx. 1.8 kg (3.97 lb) for 250 mm depth type

Approx. 2.0 kg (4.41 lb) for 300 mm depth type

Approx. 2.5 kg (5.51 lb) for 400 mm depth type

## PERFORMANCE

**Accuracy**

**DC input:**  $\pm 0.1 \%$   $\pm 1$  digit

**Thermocouple input:**  $\pm 1^\circ\text{C}$   $\pm 1$  digit

$\pm 2^\circ\text{C}$   $\pm 1$  digit for B, R, S, C and PR

**RTD input:**  $\pm 1^\circ\text{C}$   $\pm 1$  digit

**Potentiometer input:**  $\pm 0.2 \%$   $\pm 1$  digit

**DC output:**  $\pm 0.1 \%$

**Precision resistor module (REM4):**  $\pm 0.1 \%$

**Cold junction compensation:**

$\pm 2^\circ\text{C}$  at  $25^\circ\text{C} \pm 10^\circ\text{C}$

$\pm 4^\circ\text{C}$  for S, R and PR

**Temp. coefficient:**  $\pm 0.015 \%$ / $^\circ\text{C}$  ( $\pm 0.008 \%$ / $^\circ\text{F}$ )

DC input:  $\pm 0.015 \text{ }^\circ\text{C} (\pm 0.008 \text{ }^\circ\text{F})$   
Thermocouple input:  $\pm 0.015 \text{ }^\circ\text{C} (\pm 0.008 \text{ }^\circ\text{F})$   
RTD input:  $\pm 0.015 \text{ }^\circ\text{C} (\pm 0.008 \text{ }^\circ\text{F})$   
Potentiometer input:  $\pm 0.015 \text{ }^\circ\text{C} (\pm 0.008 \text{ }^\circ\text{F})$   
DC output:  $\pm 0.015 \text{ }^\circ\text{C} (\pm 0.008 \text{ }^\circ\text{F})$   
Precision resistor module (REM4):  $\pm 0.015 \text{ }^\circ\text{C} (\pm 0.008 \text{ }^\circ\text{F})$

**Line voltage effect:**  $\pm 0.1 \%$  over voltage range  
**Calendar clock accuracy:** Monthly deviation 3 minutes at  $25^\circ\text{C}$

**RAM memory duration in power failure for hot start:**  
10 minutes assured

**Insulation resistance:**  $\geq 100 \text{ M}\Omega$  with 500 V DC

**Dielectric strength:**  
1500 V AC @ 1 minute  
(Pv1 or supply output to Pv2 or Ai1 or Ai2 or Ai3 or Ai4 to Di1 or Di2 or Di3 or Di4 or Di5 or Pi1 or Pi2 or Pi3 or Pi4 or Pi5 to Di6 or Pi6 to Mv1 to Mv2 or Ao1 or Ao2 to Do1 to Do2 or Do3 or Do4 or Do5 or Do6 to NestBus to Modbus-RTU to Modbus/TCP to power to FG)  
500 V AC @ 1 minute (Pv2 to Ai1 or Ai2 or Ai3 or Ai4)  
500 V AC @ 1 minute (Mv2 to Ao1 or Ao2)  
500 V AC @ 1 minute (Do2 to Do3 to Do4 to Do5 to Do6)  
500 V AC @ 1 minute (Pv1 to supply output)

## STANDARDS & APPROVALS

**EU conformity:**  
EMC Directive  
EMI EN 61000-6-4  
EMS EN 61000-6-2  
Low Voltage Directive  
EN 61010-1  
Measurement Category II (contact output)  
Installation Category II (power)  
Pollution degree 2  
Input or output to contact output - Basic insulation (300 V)  
Input or output to power - Reinforced insulation (300 V)  
RoHS Directive  
**Protection against access to the terminal blocks:**  
Finger protection (VDE 0660-514)

## EXTERNAL VIEW

### ■ CONTROL MODULE FRONT VIEW

• Infrared communication type

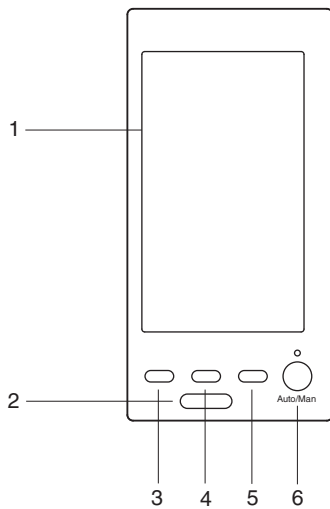

• Stereo jack type

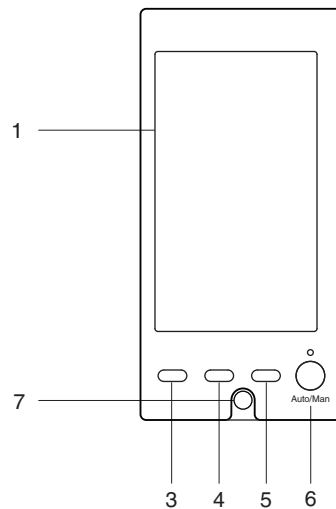

1. TFT Color LCD with touch panel  
Provides operation and engineering views to facilitate monitoring and setting
2. Infrared communication port  
Used to communicate with PC via IRDA Communication Adaptor (model: COP-IRDA) to program and change parameters using Loop Configuration Builder Software (model: SFEW3E) or PC Configurator Software (model: SCCFG)
3. MV value (DOWN) button
4. Acceleration button  
(Accelerates MV signal's changing speed by pressing simultaneously with MV value button)
5. MV value (UP) button
6. Auto / Man selector (changes the control mode for MV output)
7. Configurator jack and cap  
Connects with a PC where Loop Configuration Builder Software (model: SFEW3E) or PC configurator software (model: SCCFG) is installed via a PC configurator cable (model: COP-US) and enables programming and parameter setting

## COMMUNICATION CABLE CONNECTIONS

### ■ NestBus

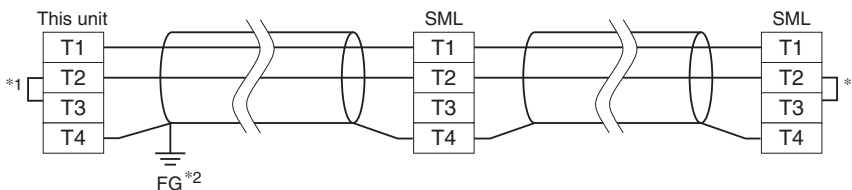

### ■ Modbus-RTU

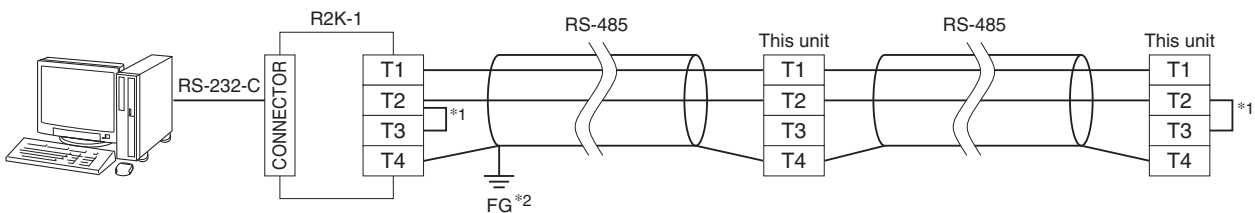

- \*1. Internal terminating resistor is used when the device is at the end of a transmission line.  
\*2. Install shield cables to all sections and ground them at single point.

## EXTERNAL DIMENSIONS & TERMINAL ASSIGNMENTS unit: mm [inch]

### ■ INFRARED COMMUNICATION TYPE

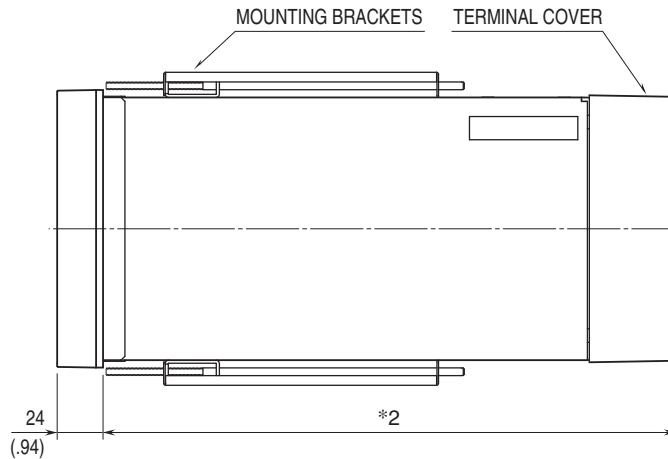
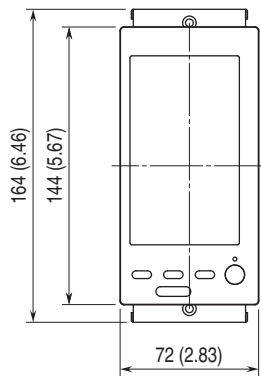
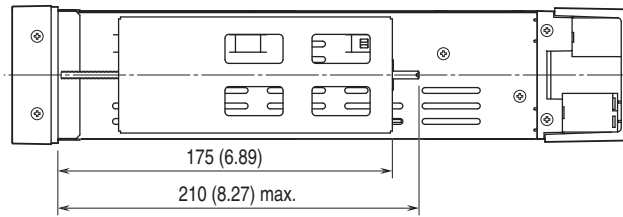

\*1. For Modbus/TCP only

\*2. Standard model: 250 mm (9.84")  
Option /3: 300 mm (11.81")  
Option /4: 400 mm (15.75")

### • ONE BLOCK TERMINAL (without option /T)

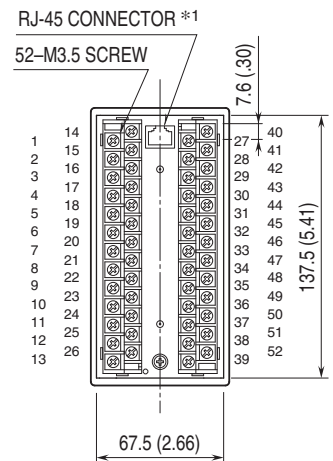

### • SEPARABLE TERMINAL (with option /T)

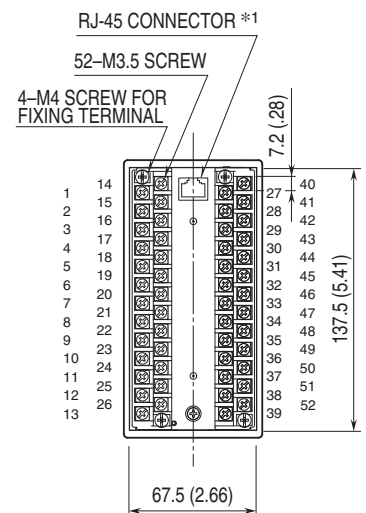

## ■ STEREO JACK TYPE

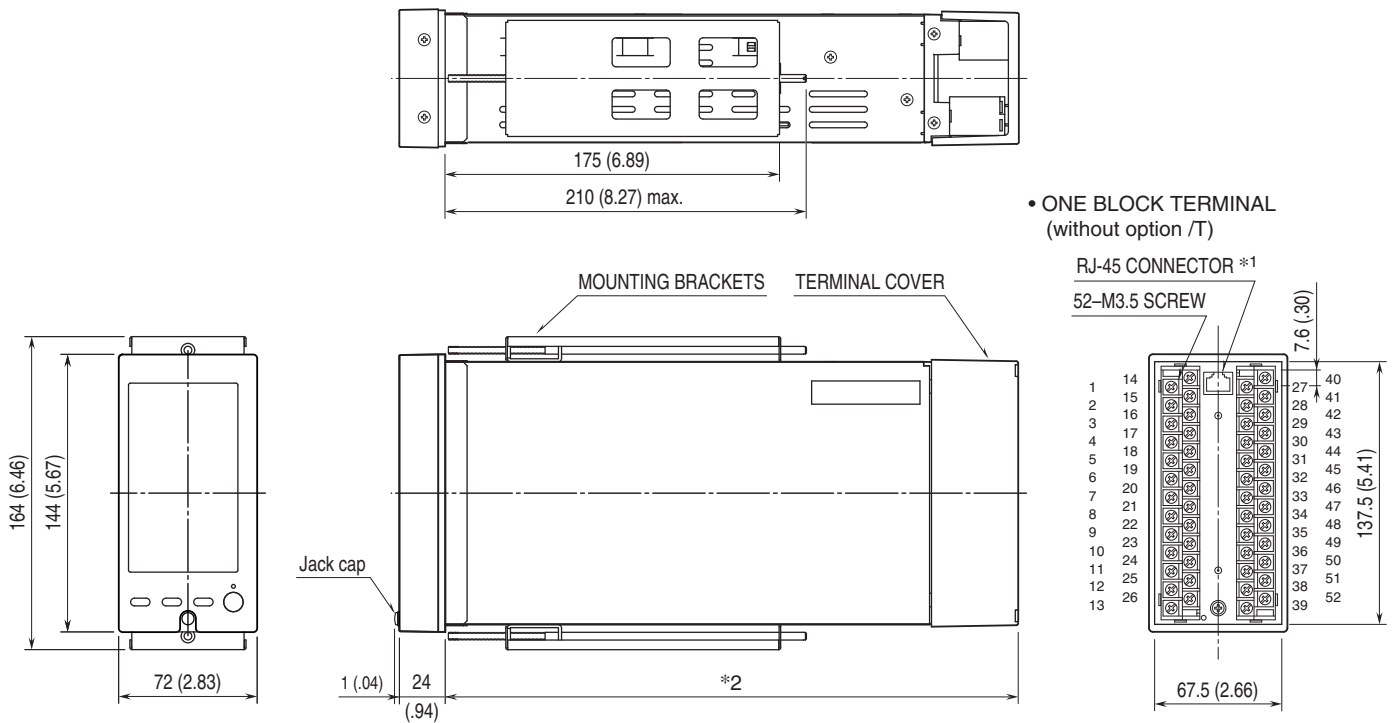

\*1. For Modbus/TCP only

\*2. Standard model: 250 mm (9.84")  
 Option /3: 300 mm (11.81")  
 Option /4: 400 mm (15.75")

• ONE BLOCK TERMINAL  
 (without option /T)

RJ-45 CONNECTOR \*1

52-M3.5 SCREW

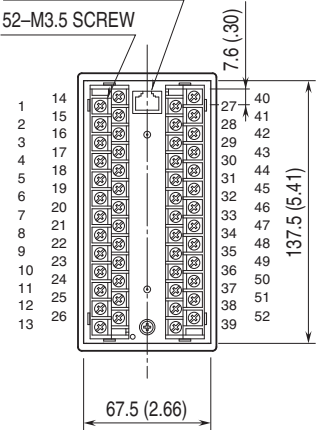

• SEPARABLE TERMINAL  
 (with option /T)

RJ-45 CONNECTOR \*1

52-M3.5 SCREW

4-M4 SCREW FOR  
 FIXING TERMINAL

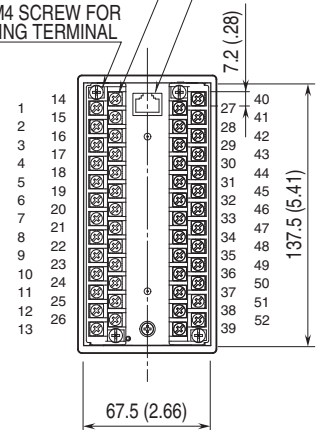



**MOUNTING REQUIREMENTS unit: mm**

■ PANEL CUTOUT unit: mm

• Single mounting

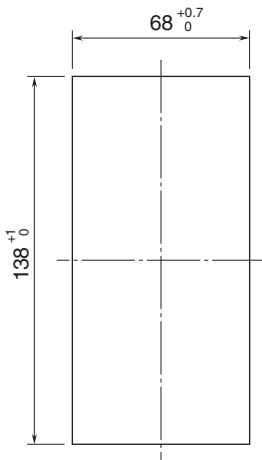

• Clustered mounting

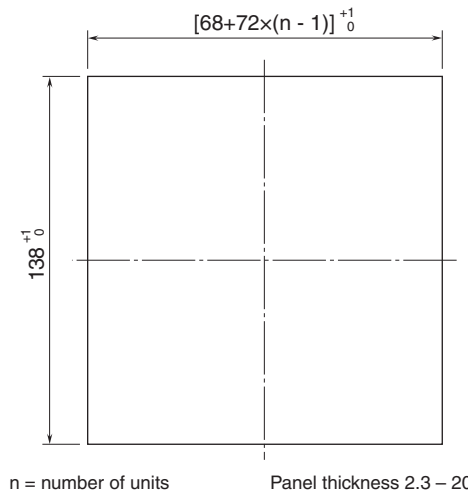

■ Caution

- IP55 is ensured for the front panel of the unit mounted independently according to a panel. Test the sealing at the mounting surface once the device is installed.
- Set the unit on a vertical surface with its operation buttons at the lower side. Mounting in other directions may cause heat built up inside the unit and shorten its life span or degrade its performance.
- Ensure that there is sufficient space for ventilation inside a panel. Do not install above the devices that generate high heat such as heaters, transformers or resistors. Leave at least 30 mm (1.2 inch) space above, below and behind the unit for maintenance purpose (e.g. wiring, removing or installing).

## SCHEMATIC CIRCUITRY & CONNECTION DIAGRAM

Note: In order to improve EMC performance, bond the FG terminal to ground.

Caution: FG terminal is NOT a protective conductor terminal.

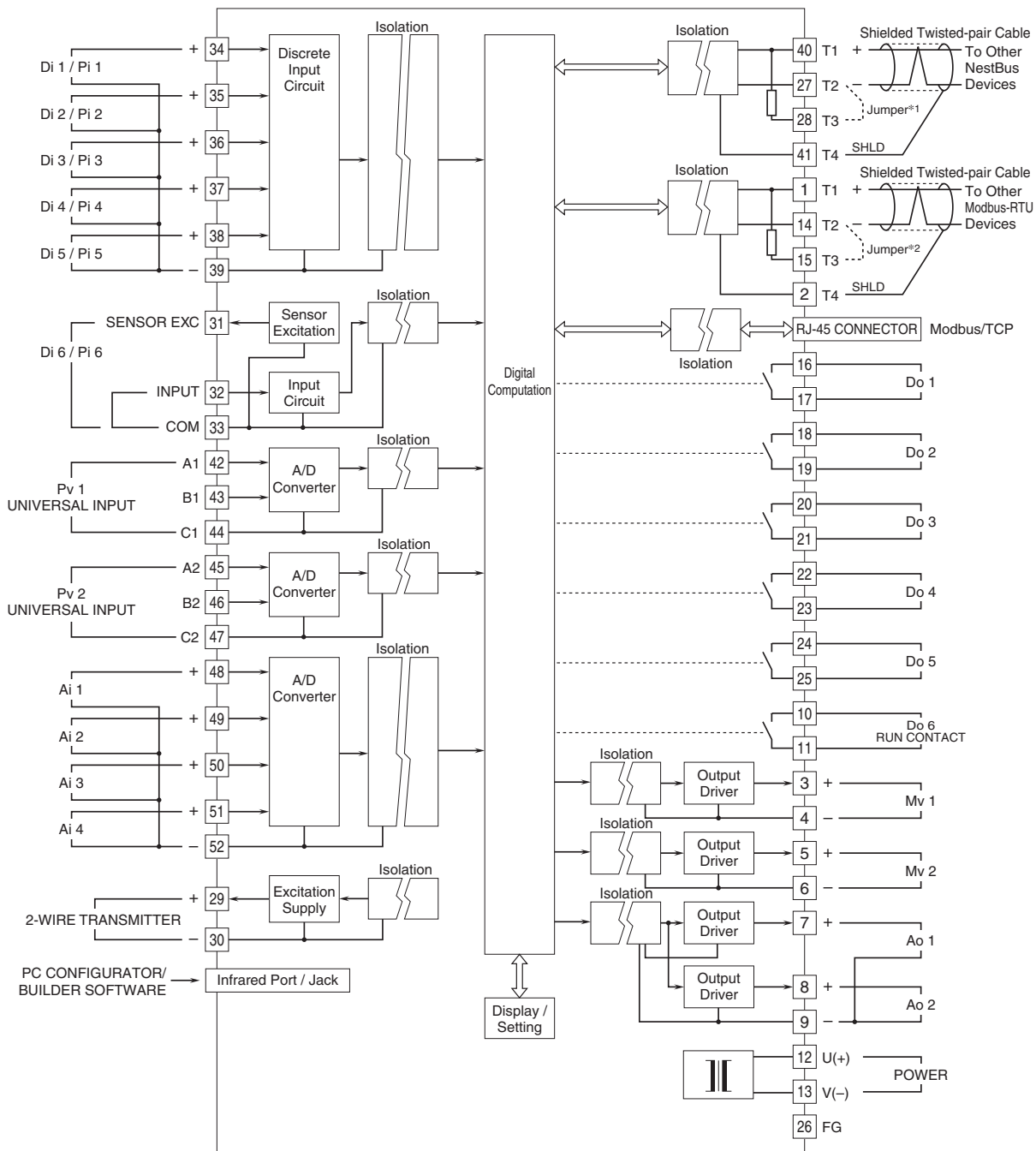

\*1. Close across the terminals 27 – 28 when the unit is located at the end of a transmission line (= no cross-wiring).  
 \*2. Close across the terminals 14 – 15 when the unit is located at the end of a transmission line (= no cross-wiring).

### ■ UNIVERSAL INPUT CONNECTION E.G.

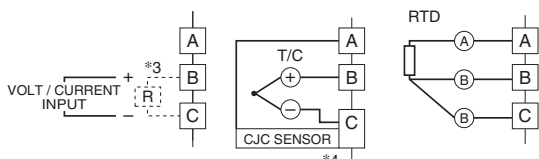

\*3. Connect input resistor module (model: REM4) for current input.  
 \*4. Connect C/JC sensor for thermocouple input.  
 \*5. Connect input resistor module (model: REM4).

### ■ DISCRETE INPUT PULSE INPUT CONNECTION E.G.:

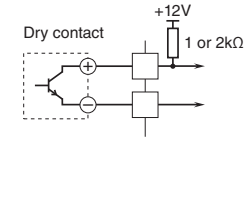

## SYSTEM CONFIGURATION EXAMPLES

### ■ SINGLE LOOP CONTROL

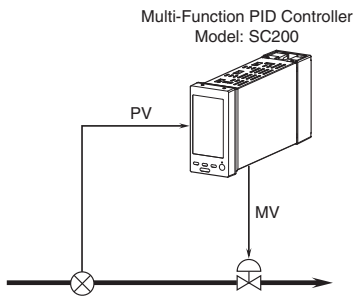

### ■ CASCADE CONTROL

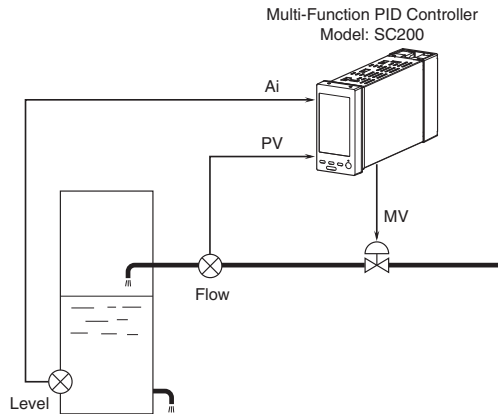

### ■ I/O EXPANDED VIA NESTBUS

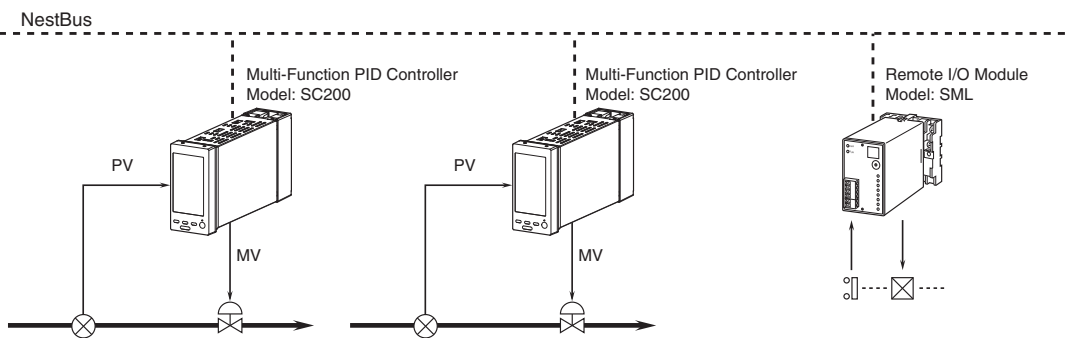

### ■ CONTROL / SUPERVISION VIA MODBUS/TCP

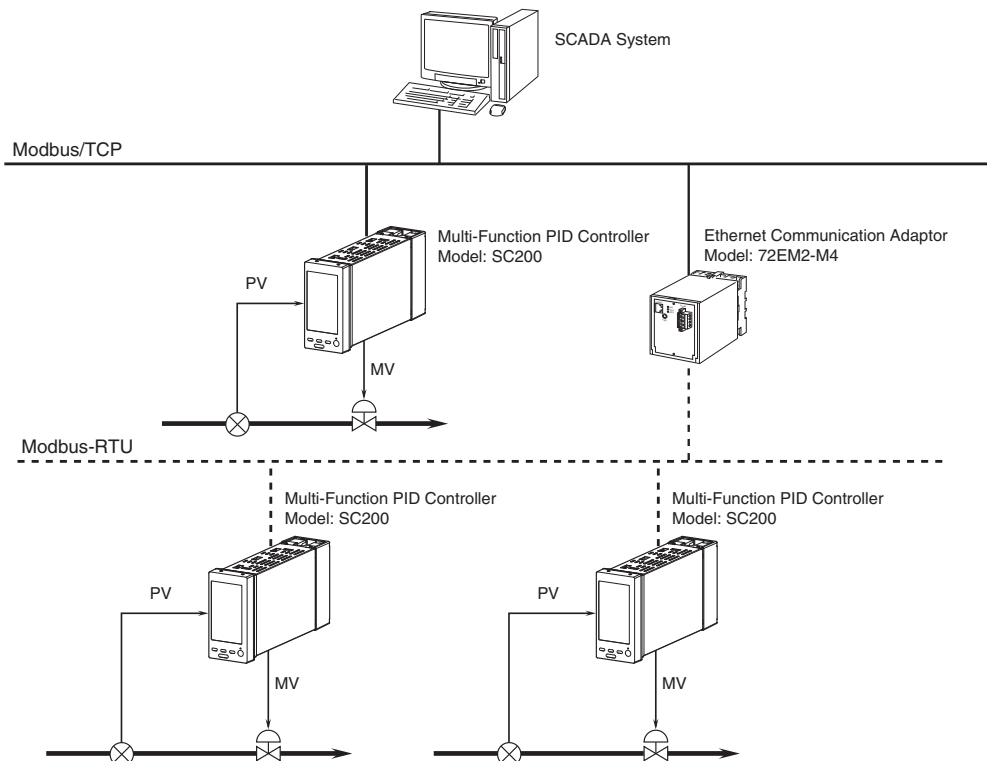

## ■ CONTROL / SUPERVISION VIA MODBUS-RTU

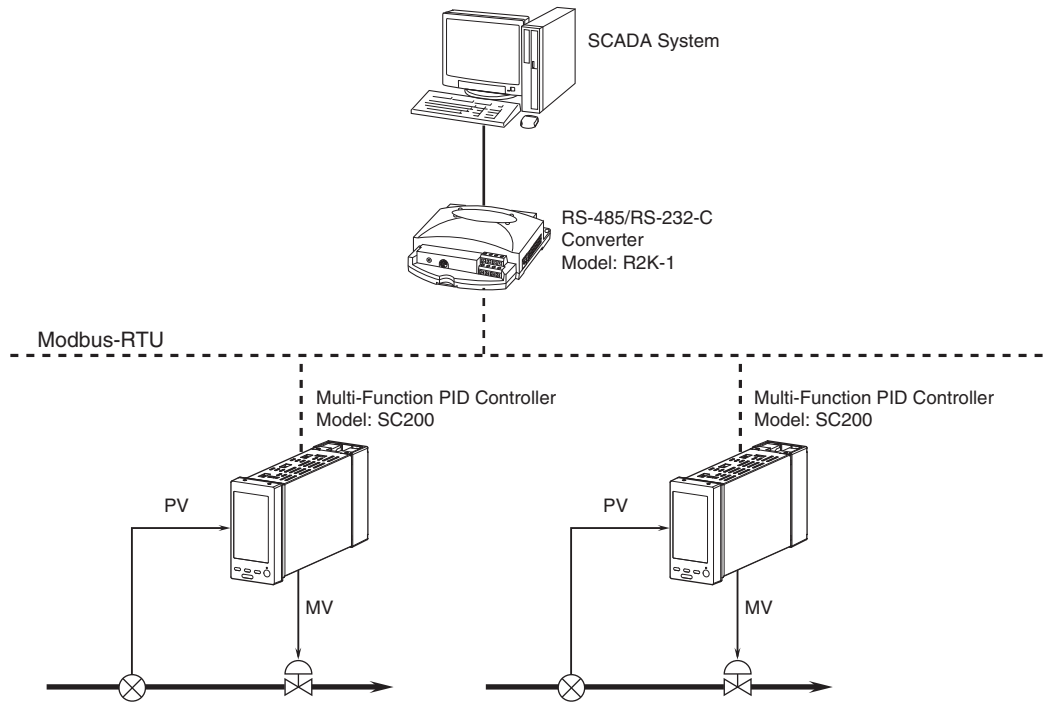

Specifications are subject to change without notice.