

UNIVERSAL INPUT MODULE

(12 points; isolated)

MODEL **RZMS-U9**

BEFORE USE

Thank you for choosing M-System. Before use, please check contents of the package you received as outlined below.

If you have any problems or questions with the product, please contact M-System's Sales Office or representatives.

This product is for use in general industrial environments, therefore may not be suitable for applications which require higher level of safety (e.g. safety or accident prevention systems) or of reliability (e.g. vehicle control or combustion control systems).

For safety, installation and maintenance of this product must be conducted by qualified personnel.

■ PACKAGE INCLUDES:

Universal input module (1)

■ MODEL NO.

Confirm Model No. marking on the product to be exactly what you ordered.

■ INSTRUCTION MANUAL

This manual describes necessary points of caution when you use this product, including installation, connection and basic maintenance procedures.

For detailed information on Modbus supported functions, refer to Modbus Protocol Reference Guide (EM-5650).

The RZMS is programmable using the PC configurator software. For detailed information on the PC configuration, refer to the RZMSCFG instruction manual. The RZMSCFG PC Configurator Software is downloadable at M-System's web site: <http://www.m-system.co.jp>.

POINTS OF CAUTION

■ CONFORMITY WITH EU DIRECTIVES

- This equipment is suitable for Pollution Degree 2 and Installation Category II (transient voltage 2500V). Reinforced insulation (power input to input or output) is maintained. Prior to installation, check that the insulation class of this unit satisfies the system requirements.
- Altitude up to 2000 meters.
- The equipment must be mounted inside a panel.
- Insert noise filters. Okaya Electric Industries Model SUP-E1H or equivalent for the power source connected to the unit, and TDK Model ZCAT 3035-1330 or equivalent for the RS-232-C cable are recommended.
- The equipment must be installed such that appropriate clearance and creepage distances are maintained to conform to CE requirements. Failure to observe these requirements may invalidate the CE conformance.
- The actual installation environments such as panel configurations, connected devices, connected wires, may affect the protection level of this unit when it is integrated in a panel system. The user may have to review the CE requirements in regard to the whole system and employ additional protective measures to ensure the CE conformity.

- Install lightning surge protectors for those wires connected to remote locations.

■ POWER INPUT RATING & OPERATIONAL RANGE

- Locate the power input rating marked on the product and confirm its operational range as indicated below:
100 – 240V AC rating: 85 – 264V, 47 – 66 Hz, approx. 5VA
24V DC rating: 24V ±10%, approx. 1.2W

■ GENERAL PRECAUTIONS

- Before you remove the module, turn off the power supply and input signal for safety.

■ ENVIRONMENT

- Indoor use.
- When heavy dust or metal particles are present in the air, install the module inside proper housing with sufficient ventilation.
- Do not install the module where it is subjected to continuous vibration. Do not subject the unit to physical impact.
- Environmental temperature must be within -5 to +60°C (23 to 140°F) with relative humidity within 30 to 90% RH in order to ensure adequate life span and operation.
- Be sure that the ventilation slits are not covered with cables, etc.

■ GROUNDING

- In order to protect the RZMS module and connected devices in connecting/disconnecting Modbus cable or the configurator cable, be sure to earth FG terminals of the RZMS and the connected device to a most stable earth point in the environment. Grounding is also effective to eliminate problems caused by noises.

■ WIRING

- Wrong connection may damage the module.
- Do not connect cables to moving parts or pull them tightly.

■ MINIMIZING NOISE INTERFERENCE TO ANALOG SIGNAL CABLES

- Noise entering through the analog signal cables may cause irregular measurement values, degradation of overall accuracy, and malfunction of the product.
- Despite the RZMS's excellent filtering capabilities against normal mode noise interference to analog signal cables, we recommend that you would conduct wiring to the product with the following points of caution, especially for low-level signals with thermocouple, mV and RTD measurements.
- Use shielded twisted-pair cables to connect analog signals and Modbus RS-485. The shield line must be grounded to the one and same earth point which is the most stable in the environment, as for the RZMS's FG terminal.
- The RZMS is capable of notch filtering the 50/60 Hz normal mode line noise. Select the operating mode setting switch at the rear side of the product or use the PC Configurator Software RZMSCFG to match the line frequency.
- The RZMS is equipped with the first order lag filter programmable by each channel.
- Use these filtering functions according to your needs. Use the PC Configurator Software RZMSCFG to enable the first order lag filter.

- The A/D Conversion Mode is factory set to 'Medium' but is programmable to 'Slow' using the PC Configurator Software RZMSCFG. In general, selecting the 'Slow' A/D conversion mode means the lower data conversion cycles, but the stronger noise filtering. Change this setting according to your needs.
- Do not install cables close to noise sources (relay drive cable, high frequency line, etc.).
- Do not bind these cables together with those in which noises are present. Do not install them in the same duct.

■ MINIMIZING CHANNEL-TO-CHANNEL COMMON MODE NOISE

- The CMNR ratio between channels are as described in the product's data sheet. Input types such as $\pm 12V$, $\pm 6V$, $\pm 3V$, $\pm 1000mV$ are mostly safe from these interferences, however, the measuring accuracies for other input types may be compromised by large common mode noise.
- As described in the data sheet, the DC/AC voltage across the C terminals of the presently-scanned channel and the last scanned channel affects the measuring values. For example, if you measure 60 Hz, 100Vrms between ch.12 and ch.1 while ch.1 is connected to a thermocouple, ch.1 measuring value could have errors by 707 μV (141 Vpeak, -106 dB).
- In order to obtain stable measuring results without noise interference, it is effective to minimize the common mode noise between channels and between each channel to FG. We recommend that C terminals of each channel be cross-wired and then connected to the FG terminal to ensure the measurement of the highest accuracy.
- If such configuration is not possible, take special consideration to minimize the channel-to-channel common mode noise and the potential against the FG. Employ a thermocouple/RTD sheath of high insulation to prevent a leak current. Do not weld a thermocouple directly to the surface of the measuring subject.
- If these precautions are not usable, we recommend the use of model R1MS-GH3, fully channel-to-channel isolated type.
- Arranging channels so that a low-level signal channel is not located next to a high potential signal channel while multiplexing these signals is also effective.
- The potential of the open terminal C against the FG equals to that of the last scanned channel. If ch 2 and ch 3 are not connected, the accuracy of ch 4 measurement is affected by potential difference between the C terminals of ch 1 and ch 4.

■ STABILIZING COLD JUNCTION COMPENSATION

- Sudden ambient temperature change could increase the cold junction compensation error by the internal terminal temperature sensor. Please take the following precautions to prevent it.
- Be sure to close the terminal cover when operating the RZMS.
- Stabilize the temperature around the terminal block. DO NOT expose the terminal block in the direct line of air flow from air conditioners, cooling fans, or ventilation fans. Switching on and off the fans located close to the terminal block affects the ambient temperature.
- Disposition of the terminals for odd-number channels is tend to be more favored in the CJC stability than those for even-number channels.

- Resistor modules (model: REM3-250) can be connected to the RZMS to convert current inputs into voltage. However, it is not recommended when TC inputs are mixed because the heat developed on and around the REM3 affects the cold junction compensation performance. We recommend that REM3 be connected on a separate terminal board.
- Do not use wires of large diameter which has large heat dissipation. We recommend using the wires of 0.5 mm² (AWG 20) or thinner diameters not only for the thermocouple channels but for all other screw terminals.
- Temperature measured at another channel of the RZMS can be specified as the reference point by using PC Configurator Software. This is beneficial to reduce compensation wires' cost when there are many temperature points in remote locations. Install a relaying terminal board near the sensors and use ordinary copper wires between the board and the RZMS, and assign one channel to measure temperature at the terminal board as the reference. Take the same precautions for the relaying terminal board, too. Also, RTD of higher accuracy is recommended to measure the relaying terminal temperature, though a thermocouple of lower accuracy could be used.

■ CONNECTING OTHER DEVICES IN PARALLEL

- Turn off the burnout function for thermocouple inputs.
- No parallel connection is permitted for RTD or potentiometer inputs.

■ TWO-WIRE RTD

- The product is designed for use with three-wire RTDs, measuring continuously the voltage drop caused by wire resistance. However, two-wire RTD can be used by closing across B and C terminals.
- After the RTDs are wired, short across the RTD wires and perform the wire resistance compensation by PC Configurator Software RZMSCFG. Be sure to enable the wire resistance compensation.

■ DO NOT APPLY OVERRANGE NORMAL MODE VOLTAGE

- Do not apply voltages exceeding $\pm 20V$ to terminals B – C for $\pm 3V$, $\pm 6V$ or $\pm 12V$ ranges to prevent damage.
- For other ranges, do not apply voltages exceeding $\pm 12V$ to the same terminals to prevent damage. Applying voltages exceeding $\pm 1.5V$ may affect the measuring accuracies of other channels.

■ AND

- The module is designed to function as soon as power is supplied, however, a warm up for 10 minutes is required for satisfying complete performance described in the data sheet.

COMPONENT IDENTIFICATION

TOP VIEW

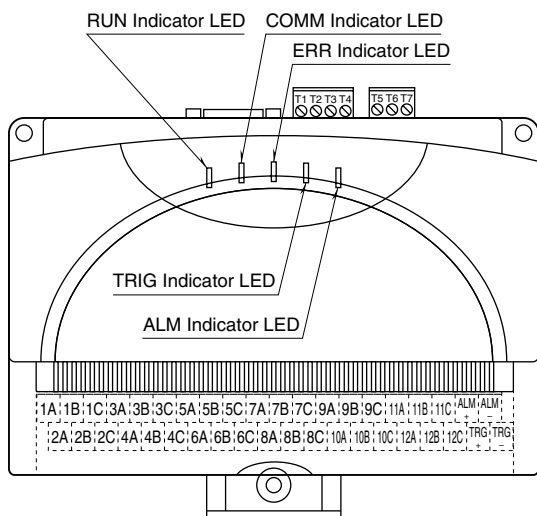

REAR VIEW

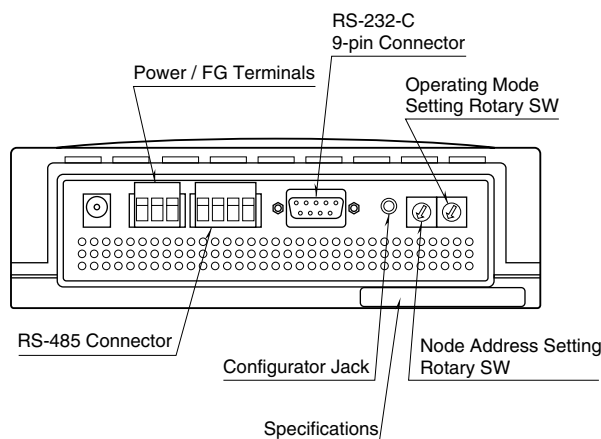

INDICATOR LED

- RUN:** Green LED blinks when the internal micro-processor is operating normally.
- COMM:** Communication LED. Amber LED turns on when the RZMS is receiving normal data query frames from Modbus and sending responses out.
- ERR:** Error LED. Red LED turns on with internal errors and blinks when the RZMS is receiving abnormal data query frames from Modbus.
ERR LED may blink when Modbus master is not receiving data. There is no error or problem if ERR LED turns OFF when Modbus master started receiving data. (Some PCs output error signals (break signals) when COM ports are not used by any application programs. RZMS-U9 causes ERR LED to blink upon reception of such signals.)

- TRG:** Trigger LED. Amber LED turns on when the trigger contact input turns on.
- ALM:** Alarm LED. Amber LED turns on when the alarm contact output turns on.

NODE ADDRESS SETTING ROTARY SW

- 1 through F:** Setting at the power startup is recognized as the module's node address.
- 0:** Setting with PC Configurator Software is enabled. Software settings are deleted if the RZMS is started up with a setting other than zero (0).

OPERATING MODE SETTING ROTARY SW

A/D conversion mode, service channel numbers, cold junction compensation, line noise filter frequency and burnout action for T/C and RTD input can be specified using this switch. Setting with PC Configurator Software is enabled when the switch is set to zero (0). In order to protect the software setting before the power is turned off, be sure to turn the power supply on with '0' setting.

1 through F: Combination of settings as shown in the table below.

0: Last software setting before the power is turned off is enabled.

A/D CONVERSION MODE	SERVICE CHANNEL NUMBERS	COLD JUNCTION COMPENSATION (T/C)	LINE NOISE FILTER FREQUENCY	BURNOUT (T/C and RTD)			
				All Channels			Individual Channels
				NONE	UP	DOWN	
Medium	12	With	50/60 Hz	1	2	3	
			50 Hz	4	5	6	
		Without	60 Hz	7	8	9	
			50 Hz	A	B	C	
60 Hz	D	E	F				
Software setting for all channels (Fast, Medium, Slow)	Software setting (12 or 6)	Software setting for individual channels	Software setting for all channels (50, 60, 50/60 Hz)				0 Software setting

Note 1: Specifying the exact frequency (50 Hz and 60 Hz) provides better protection than 50/60 Hz setting.

Note 2: Factory setting is '1.'

INSTALLATION

■ DIN RAIL MOUNTING

Set the body so that its DIN rail adaptor is at the bottom. Pull down the DIN rail adaptor.

Position the upper hook at the rear side on the DIN rail and push in the lower. Push back the DIN rail adaptor.

When the module is mounted on a DIN rail attached on the wall surface in vertical direction, use of an attachment plate to prevent the module from sliding down is recommended.

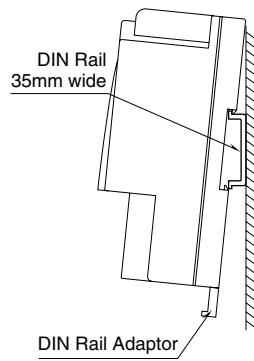

■ WALL MOUNTING

Set the body so that its DIN rail adaptor is at the bottom.

Pull down the DIN rail adaptor.

Refer to "EXTERNAL DIMENSIONS."

TERMINAL CONNECTIONS

Connect the module referring to the connection diagram.

■ EXTERNAL DIMENSIONS unit: mm (inch)

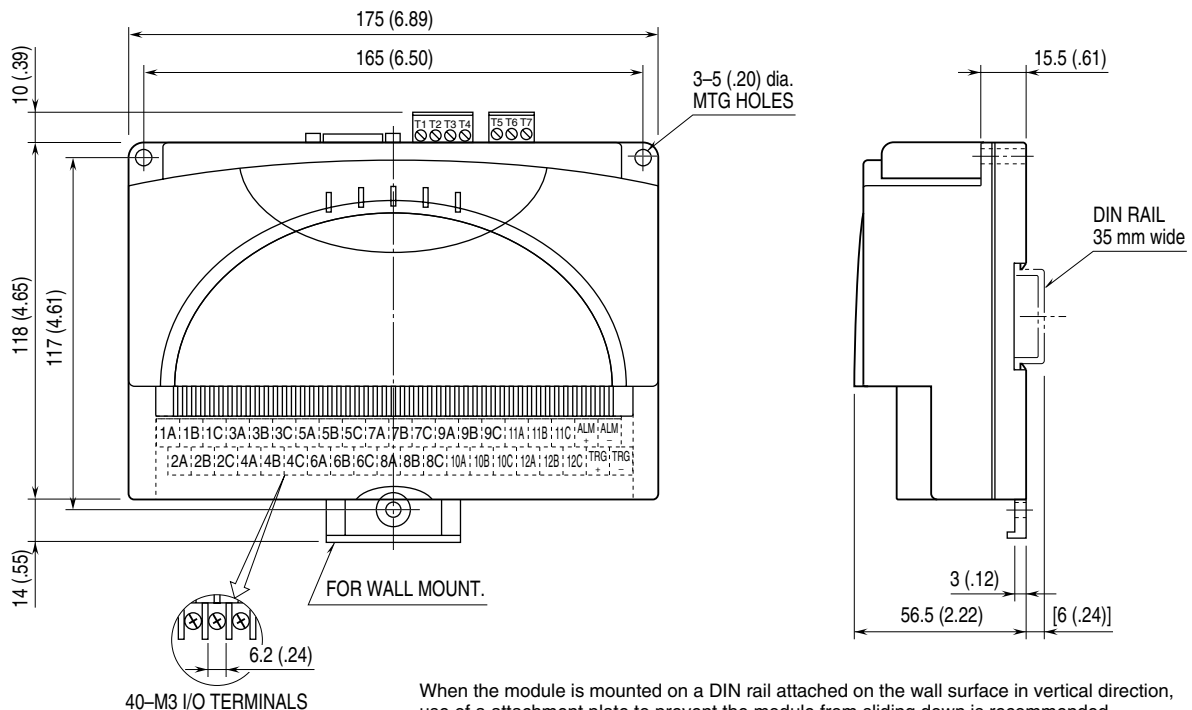

■ CONNECTING DIAGRAM

Note: In order to improve EMC performance, bond the FG terminal to ground.

Caution: FG terminal is NOT a protective conductor terminal.

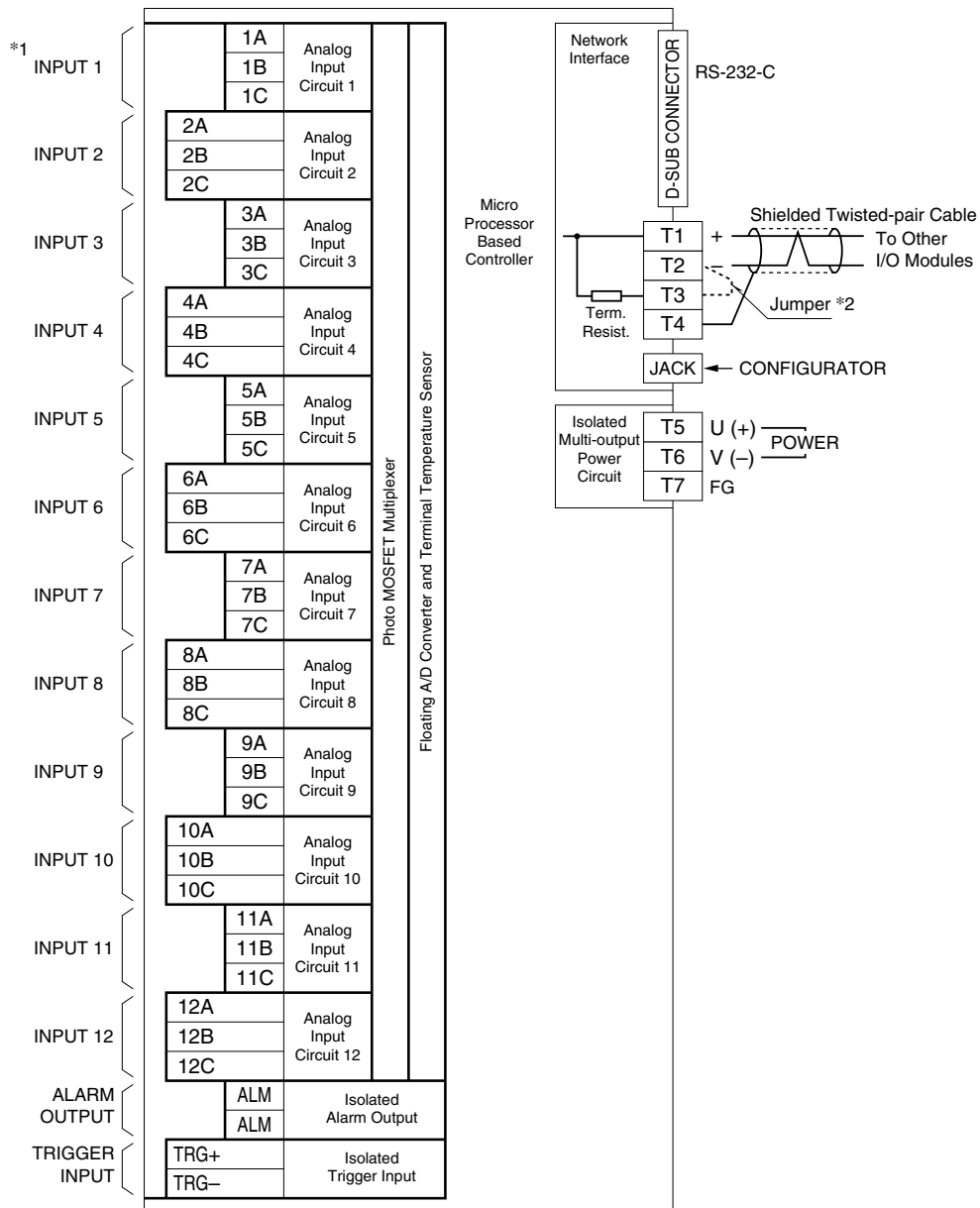

*1 Input Connection Examples

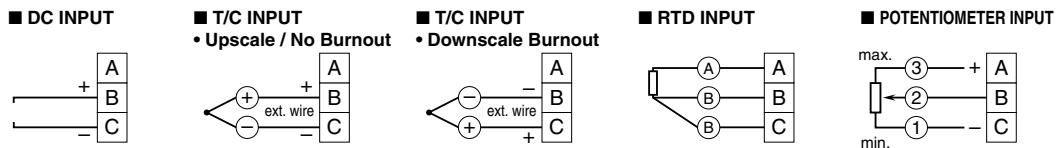

*2 When the device is located at the end of a transmission line via twisted-pair cable, (when there is no cross-wiring), close across the terminal T2 – T3 with the attached jumper pin (or with a leadwire).
When the device is not at the end, remove the jumper pin.

- Note 1: In order to protect the RZMS-U9 module and connected devices in connecting/disconnecting Modbus cable or the configurator cable, be sure to earth FG terminals of the RZMS-U9 and the connected device to a most stable earth point in the environment. Grounding is also effective to eliminate problems caused by noises.
- Note 2: Be careful to eliminate noise as much as possible by e.g. using shielded cables.
- Note 3: The smaller is common mode voltage (DC and AC) between C terminals and between C and FG, the better is measuring accuracy. Connecting between C terminals and if possible to FG will yield the best accuracy.
- Note 4: Resistor modules (model: REM3-250) can be connected to 1A through 12C terminals to convert current inputs into voltage. However, it is not recommended when TC inputs are mixed because the heat developed on and around the REM3 affects the cold junction compensation performance. We recommend that REM3 be connected on a separate terminal board.
- Note 5: When the internal temperature sensors are used for CJC, temperature imbalance around the terminal block affects greatly the CJC accuracy. In order to minimize such imbalance, do not use wires of large diameter which has large heat dissipation. Be sure to close the terminal cover. Do not expose the module directly in the line of wind from a cooling fan.
- Note 6: Two-wire RTD can be used by closing across B and C terminals. Be sure to compensate wire resistance by PC Configurator Software.

■ RS-232-C INTERFACE



ABBR.	PIN NO.	EXPLANATION OF FUNCTION
BA (SD)	2	Transmitted Data
BB (RD)	3	Received Data
AB (SG)	5	Signal Common
CB (CS)	7	Clear to Send
CA (RS)	8	Request to Send
	1	Not Used.
	4	DO NOT connect. Connecting may cause malfunctions.
	6	
	9	

■ RS-232-C CABLE

- Use a 'Straight' cable to connect the module to a PC if not with the cable included in the product package.
 - For connecting the module to the R1M or the R2K-1 via RS-232-C, the RS-232-C cable must satisfy the following conditions:
 - (1) Includes the connections shown with solid lines in the figure below.
 - (2) Pins No. 8 are not connected between each other. (May cause breakdowns.)
- 'Interlink' or 'Reverse' cables are usually applicable.

• Pin Assignments

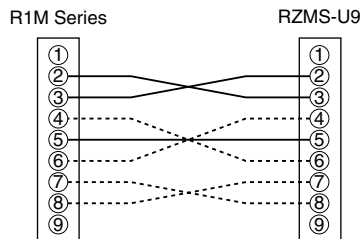

The above connection including solid and broken lines is an example of 'Interlink' cable.

WIRING INSTRUCTIONS

■ M3 SCREW TERMINAL (I/O signal)

Torque: 0.6 N·m

■ SOLDERLESS TERMINAL

Refer to the drawing below for recommended ring tongue terminal size. Spade tongue type is also applicable. Applicable wire size: 0.75 to 1.25 mm² (AWG19 to 16) Recommended manufacturer: Japan Solderless Terminal MFG.Co.Ltd, Nichifu Co.,Ltd

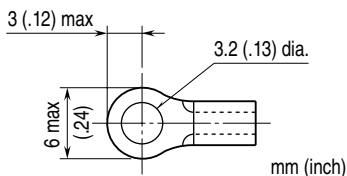

■ EURO TYPE CONNECTOR TERMINAL (Power input, Modbus)

Applicable wire size: 0.2 to 2.5 mm² (AWG24 to 12) Stripped length: 7 mm

CHECKING

- 1) Terminal wiring: Check that all cables are correctly connected according to the connection diagram.
- 2) Power input: Check supply voltage.
- 3) Input: Check that the input is within 0 – 100% of full-scale.

ADJUSTMENT PROCEDURE

This unit is calibrated at the factory to meet the ordered specifications, therefore you usually do not need any calibration. However, PC Configurator Software RZMSCFG is available to trim zero and span if such needs arise in order to adjust the input sensor range. For RTD measuring, wire resistance can be compensated on site using the RZMSCFG.

MAINTENANCE

Regular calibration procedure is explained below:

■ CALIBRATION

Warm up the unit for at least 10 minutes. Apply 0%, 25%, 50%, 75% and 100% input signal. Check that the output signal for the respective input signal remains within accuracy described in the data sheet. When the output is out of tolerance, please contact M-System's Sales Office or representatives.

COMMUNICATION CABLE CONNECTIONS

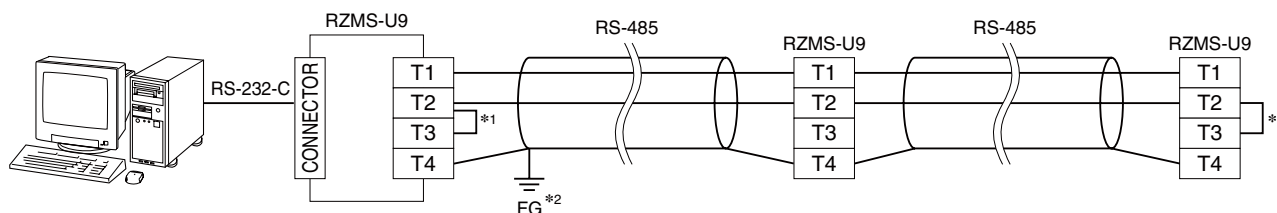

*1. Internal terminating resistor is used when the device is at the end of a transmission line.
 *2. Install shielded cables to all sections and ground them at single point.

MODBUS COMMUNICATION

COMMUNICATION PARAMETERS

PARAMETER	RZMS
Data Mode	RTU
Baud Rate	9600 / 19200 / 38400 (*) bps
Parity	None / Odd (*) / Even
Bit Length	8
Stop Bit	1 (*) / 2
Node Address	1 (*) to 15
Floating Point Data	Normal (*) / Swapped
Interface	RS-232-C / RS-485

(*) Ex-factory setting

FUNCTION CODES & SUPPORTED CODES

CODE	NAME		
01	Read Coil Status	X	Digital output from the slave
02	Read Input Status	X	Status of digital inputs to the slave
03	Read Holding Registers	X	General purpose register within the slave
04	Read Input Registers	X	Collected data from the field by the slave
05	Force Single Coil	X	Digital output from the slave
06	Preset Single Registers	X	General purpose register within the slave
07	Read Exception Status		
08	Diagnostics		
09	Program 484		
10	Poll 484		
11	Fetch Comm. Event Counter		Fetch a status word and an event counter
12	Fetch Comm. Event Log		A status word, an event counter, a message count and a field of event bytes
13	Program Controller		
14	Poll Controller		
15	Force Multiple Coils	X	Digital output from the slave
16	Preset Multiple Registers	X	General purpose register within the slave
17	Report Slave ID		Slave type / 'RUN' status
18	Program 884/M84		
19	Reset Comm. Link		
20	Read General Reference		
21	Write General Reference		
22	Mask Write 4X Register		
23	Read/Write 4X Register		
24	Read FIFO Queue		

DATA ADDRESS

	ADDRESS	DATA FORMAT	NAME
Coil (0X)	1	bit	Alarm output
	33 – 44	bit	Cold junction compensation SW
Input Status (1X)	1	bit	Trigger contact input
	33 – 44	bit	ADC overrange
Input Register (3X)	1 – 12	I	Analog input, integer
	17 – 40	F	Analog input, floating point (engineering unit value V, °C, %)
	49 – 72	F	Terminal temperature per channel (°C)
	81 – 92	I	Channel status
	201 – 224	F	Analog input, raw data (V, Ω, %)
	302	I	Mode switch setting
	513	I	Analog input status
	514 – 521	B16	Model No.
522 – 529	B16	Serial No.	
Holding Register (4X)	530 – 537	B16	Hardware version No.
	538 – 545	B16	Firmware version No.
	49 – 72	F	Input filter time constant per channel (seconds)
	145 – 156	I	Input type No. per channel
	161 – 172	I	Burnout type per channel
	573	I	Line noise filtering frequency

bit = 1 bit, I = 16-bit integer, F = 32-bit floating, B16 = 16-byte character

Accessing addresses other than described above may affect the device operation or cause errors.

Alarm output (00001, 1 bit)

0 at contact OFF; 1 at contact ON.

Cold junction compensation SW per channel (00033 – 00044, 1 bit)

Cold junction compensation enabled or disabled per each analog input channel. 0 to disable; 1 to enable. Selectable only when the mode switch is set to 0.

Trigger input (10001, 1 bit)

0 at contact OFF; 1 at contact ON.

Input error per channel (10033 – 10044, 1 bit)

Indicates analog input status per channel. 0 in normal status; 1 in abnormality. This bit is turned to 1 when one or more bits of 1 – 7 at 'Channel Status' (30081 – 30092) is turned to 1.

Analog input, integer (30001 – 30012, 16-bit integer)

Analog signal input measured at ch.1 – ch.12 is indicated in integer, in the unit as shown below:

- DC input, ±12V or ±6V range: 1mV
- DC input, ±3V, ±1000mV or ±500mV range: 0.1mV
- DC input, ±250mV, ±125mV, ±60mV: 0.01mV
- Thermocouple or RTD input: 0.1°C
- Potentiometer input: 0.01%

Analog input, floating point (30017 – 30040, 32-bit floating)

Analog signal input measured at ch.1 – ch.12 is indicated in integer, in the engineering unit as shown below:

- DC input: V
- Thermocouple or RTD input: °C
- Potentiometer input: %

Terminal temperature per channel (30049 – 30072, 32-bit floating)

Temperature at ch.1 – ch.12 terminals measured by the internal temperature sensors. Unit in °C.

Channel status (30081 – 30092, 16-bit integer)

Indicates status at ch.1 – ch.12.

Refer to the table below.

BIT	STATUS INFORMATION
1	Input voltage error across the terminals A – C 0 : Normal 1 : Out of normal measuring range
2	Input voltage error across the terminals B – C 0 : Normal 1 : Out of normal measuring range
3	Photo MOSFET control error
5	Scan error Taking 1.5 seconds or longer scan cycles.
6	Burnout for thermocouple or RTD input 0 : Measured temperature is within the defined temperature range, and no wire breakdown. 1 : Measured temperature is out of the defined temperature range and/or wire breakdown.
7	ADC error
12	Cold junction compensation SW 0 : Disabled 1 : Enabled
Other	Reserved for system use

Analog input, raw data (30201 – 30224, 32-bit floating)

Analog signal input measured at ch.1 – ch.12 before zero/span adjustment and the first order lag filtering, in engineering unit as shown below:

- DC input: V
- Thermocouple: V
(e.m.f. with the cold junction compensation)
- RTD: Ω (resistance)
- Potentiometer input: %

Analog input status (30513, 16-bit integer)

Indicates analog input control status. 0 in normal status; 1 in abnormality.

Refer to the table below.

BIT	STATUS INFORMATION
5	Scan error Taking 1.5 seconds or longer scan cycles.
6	ADC error
7	Photo MOSFET control error

Model No. (30514 – 30521, 16-bit integer)

Serial No. (30522 – 30529, 16-bit integer)

Hardware version No. (30530 – 30537, 16-bit integer)

Firmware version No. (30538 – 30545, 16-bit integer)

Input filter time constant per channel (40049 – 40072, 32-bit floating)

0 to disable; up to 500 seconds selectable.

Input type No. per channel (40145 – 40156, 16-bit integer)

NO.	INPUT TYPE	NO.	INPUT TYPE
00	±12V	30	Pt 100 (JIS '97/IEC)
01	±6V	31	Pt 200
02	±3V	32	Pt 300
03	±1000mV	33	Pt 400
04	±500mV	34	Pt 500
05	±250mV	35	Pt 1000
06	±125mV	36	Pt 50Ω (JIS '81)
07	±60mV	37	Pt 100 (JIS '89)
10	(PR)	38	JPt 100 (JIS '89)
11	K (CA)	39	Ni 100
12	E (CRC)	3A	Ni 120
13	J (IC)	3B	Ni 508.4Ω
14	T (CC)	3C	Ni-Fe 604
15	B (RH)	3D	Cu 10 @25°C
16	R	50	POT 200Ω
17	S	51	POT 500Ω
18	C (WRe 5-26)	52	POT 5kΩ
19	N		
1A	U		
1B	L		
1C	P (Platinel II)		

Burnout type per channel (400161 – 400172, 16-bit integer)

0 to disable; 1 for upscale; 2 for downscale. Selectable only when the mode switch is set to 0.

Line noise filtering frequency (40573, 16-bit integer)

0 for 50/60 Hz; 1 for 50 Hz; 2 for 60 Hz. Selectable only when the mode switch is set to 0.

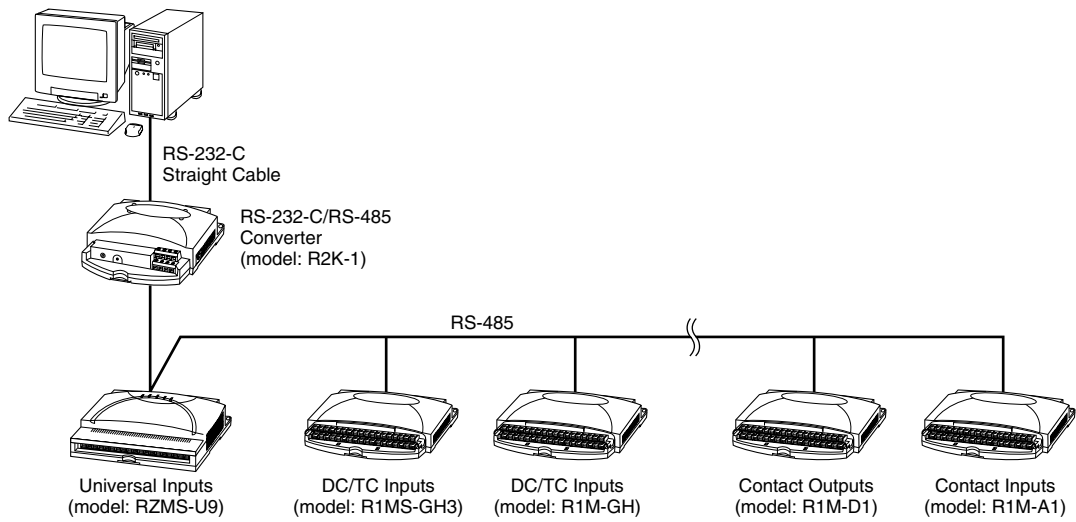
SYSTEM CONFIGURATION EXAMPLE

When the cable distance between the PC and the I/O modules is long,
insert an RS-232-C/RS-485 Converter for isolation.