

PC RECORDER**(4 totalized counter inputs, 8 contact inputs and outputs)**

MODEL

R1M-P4**BEFORE USE**

Thank you for choosing M-System. Before use, please check contents of the package you received as outlined below.

If you have any problems or questions with the product, please contact M-System's Sales Office or representatives.

This product is for use in general industrial environments, therefore may not be suitable for applications which require higher level of safety (e.g. safety or accident prevention systems) or of reliability (e.g. vehicle control or combustion control systems).

For safety, installation and maintenance of this product must be conducted by qualified personnel.

■ PACKAGE INCLUDES:

PC Recorder(1)
 Cable (9-pin D-sub cable, straight type)(1)
 CD (software and users manual).....(1)

■ MODEL NO.

Confirm Model No. marking on the product to be exactly what you ordered.

■ INSTRUCTION MANUAL

This manual describes necessary points of caution when you use this product, including installation, connection and basic maintenance procedures. Read also the Users Manual for the software included in the CD for maximum use of the PC Recorder.

POINTS OF CAUTION**■ POWER INPUT RATING & OPERATIONAL RANGE**

- Locate the power input rating marked on the product and confirm its operational range as indicated below:
 100 – 240V AC rating: 85 – 264V, 47 – 66 Hz, approx. 10VA
 24V DC rating: 24V ±10%, approx. 7W

■ GENERAL PRECAUTIONS

- Before you remove the module, turn off the power supply, input signal and output signal for safety.

■ PC RECORDER SOFTWARE

- Use the latest version of PC Recorder Software included in the product package.

■ ENVIRONMENT

- Indoor use.
- When heavy dust or metal particles are present in the air, install the module inside proper housing with sufficient ventilation.
- Do not install the module where it is subjected to continuous vibration. Do not subject the unit to physical impact.
- Environmental temperature must be within -5 to +60°C (23 to 140°F) with relative humidity within 30 to 90% RH in order to ensure adequate life span and operation.
- Be sure that the ventilation slits are not covered with cables, etc.

■ WIRING

- Wrong connection may damage the module.
- Do not connect cables to moving parts or pull them tightly.
- Do not install cables close to noise sources (relay drive cable, high frequency line, etc.).
- Do not bind these cables together with those in which noises are present. Do not install them in the same duct.

■ AND

- The module is designed to function as soon as power is supplied, however, a warm up for 10 minutes is required for satisfying complete performance described in the data sheet.

PC REQUIREMENTS (provided by the user)

■ MSR128-V6

	NORMAL MODE (storing rates \geq 500 ms)	HIGH SPEED MODE (storing rates 100 / 200 ms)
PC	IBM PC/AT or compatible	
Operating system	Windows XP SP1, SP2, Windows Vista Business 32-bit, Windows 7 Professional 32-bit or Windows 10 32-bit, 64-bit Note: Proper software functions may not be ensured under certain conditions.	
CPU	Pentium III 800 MHz or higher	Pentium IV 2.0 GHz or higher
Screen area	1024 by 768 pixels or better resolution	
Display color	65000 colors (16 bits)	
Video memory	2 MB minimum; 4 MB recommended	4 MB minimum
Main memory	256 MB recommended for Windows XP 1 GB recommended for Windows Vista, Windows 7, Windows 10	512 MB recommended for Windows XP 1 GB recommended for Windows Vista, Windows 7, Windows 10
Hard disk area	Use an internal hard disk. *1 Max. approx. 100 MB required per day.	Use an internal hard disk. *1 Max. approx. 500 MB required per day.
Printer	Use a printer for Windows. The programs use Standard System Fonts used in Windows. Use a printer driver for Standard System Fonts.	
CD drive	Windows supported CD drive is used to install the software program.	
Card reader drive	Used with devices which save data in a CF Card	
Communication port	RS-232-C port (COM1 through COM5) supported LAN card	LAN card by Windows

*1. External (e.g. SCSI) devices may impair appropriate performance.

■ MSR128LS, MSR128LV

	MSR128LS	MSR128LV
PC	IBM PC/AT or compatible	
Operating system	Windows XP SP1 or SP2. For High Speed Mode (Group 0, 50 msec. storing cycle), use Windows XP SP1, SP2. Note: Proper software functions may not be ensured under certain conditions.	
CPU	Pentium II 233 MHz or higher *2	
Screen area	800 by 600 pixels or better resolution	640 by 480 pixels or better resolution
Display color	65000 colors (16 bits)	
Main memory	256 MB for Windows XP	
Hard disk area	200 MB minimum *3 Follow the respective OS's standard for Windows XP.	
CD drive	Windows supported CD drive is used to install the software program.	
Communication port	RS-232-C port (COM1 through COM5) supported by Windows *4 or LAN communication card	

*2. Alternately, Celeron 300 MHz or higher with the secondary cache.

For High Speed Mode (Group 0, 50 msec. storing cycle), Pentium III 800 MHz or higher.

*3. External (e.g. SCSI) devices may impair appropriate performance.

*4. The RS-232-C port may be predefined for other purposes than for COM port.

Driver software change or system configuration may be required before using such a port.

Note 1: At 50 msec. storing cycle (Group 0), the MSR128LS/LV may not be able to store every bit of data depending upon the PC's performance levels. These missing data will be substituted by the last stored data. Only one (1) node is connectable in the high speed mode.

Note 2: Please refer to the hardware data sheet for response time of the module.

COMPONENT IDENTIFICATION

■ TOP VIEW

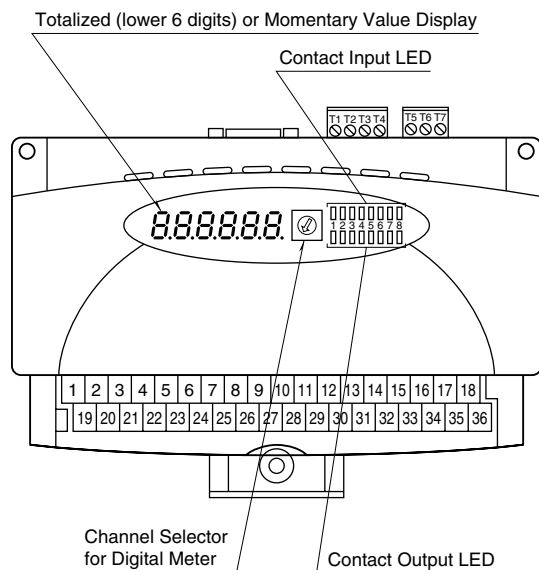

■ BOTTOM VIEW

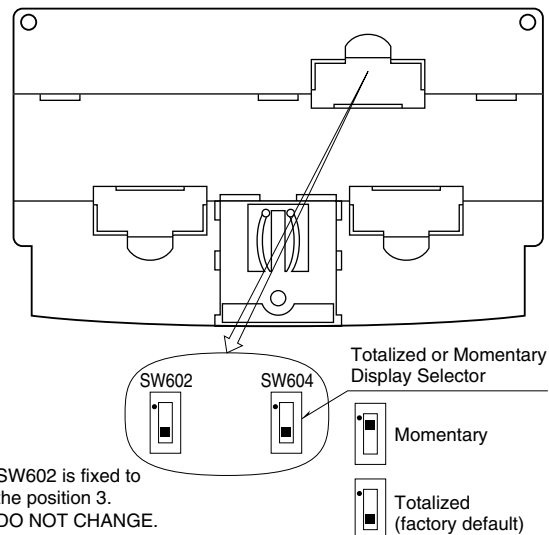

■ REAR VIEW

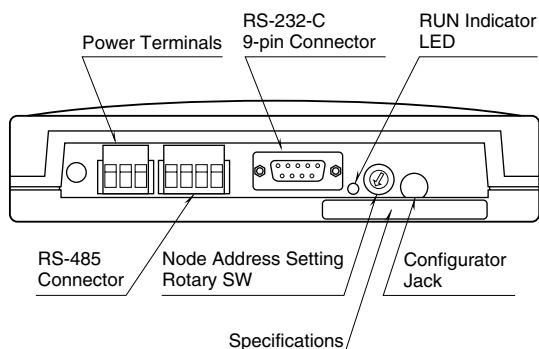

INSTALLATION

■ DIN RAIL MOUNTING

Set the body so that its DIN rail adaptor is at the bottom. Pull down the DIN rail adaptor. Position the upper hook at the rear side on the DIN rail and push in the lower. Push back the DIN rail adaptor.

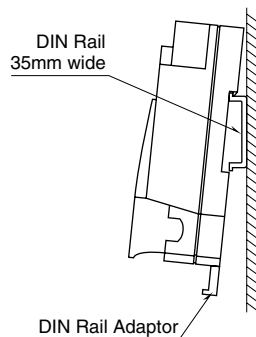

■ WALL MOUNTING

Set the body so that its DIN rail adaptor is at the bottom. Pull down the DIN rail adaptor. Refer to "EXTERNAL DIMENSIONS."

TERMINAL CONNECTIONS

Connect the unit as in the diagram below.

EXTERNAL DIMENSIONS unit: mm (inch)

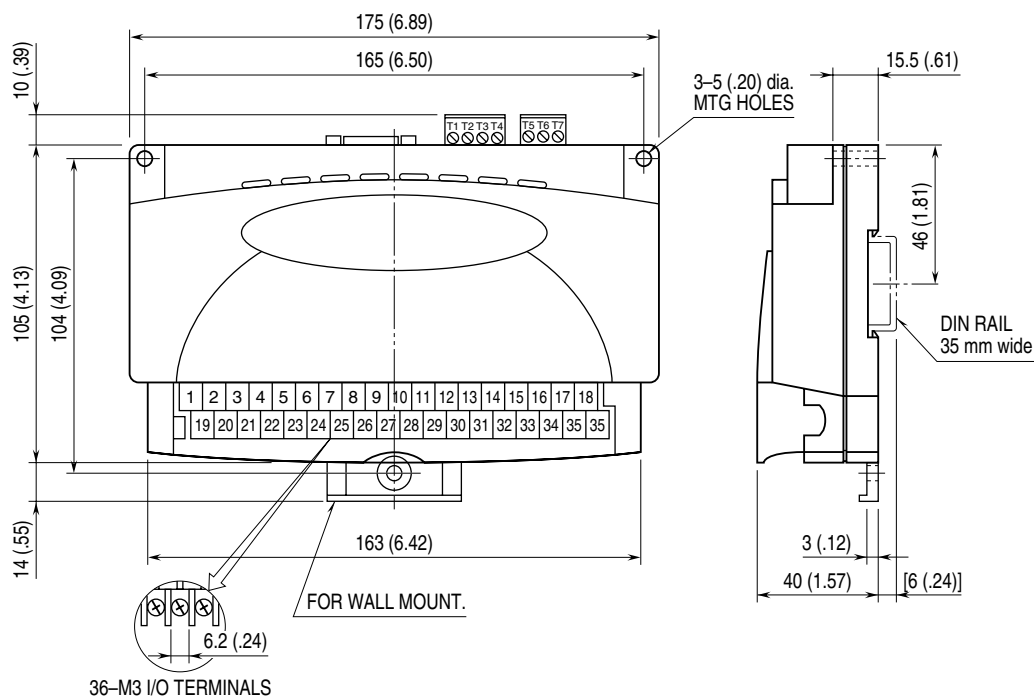

■ CONNECTION DIAGRAM

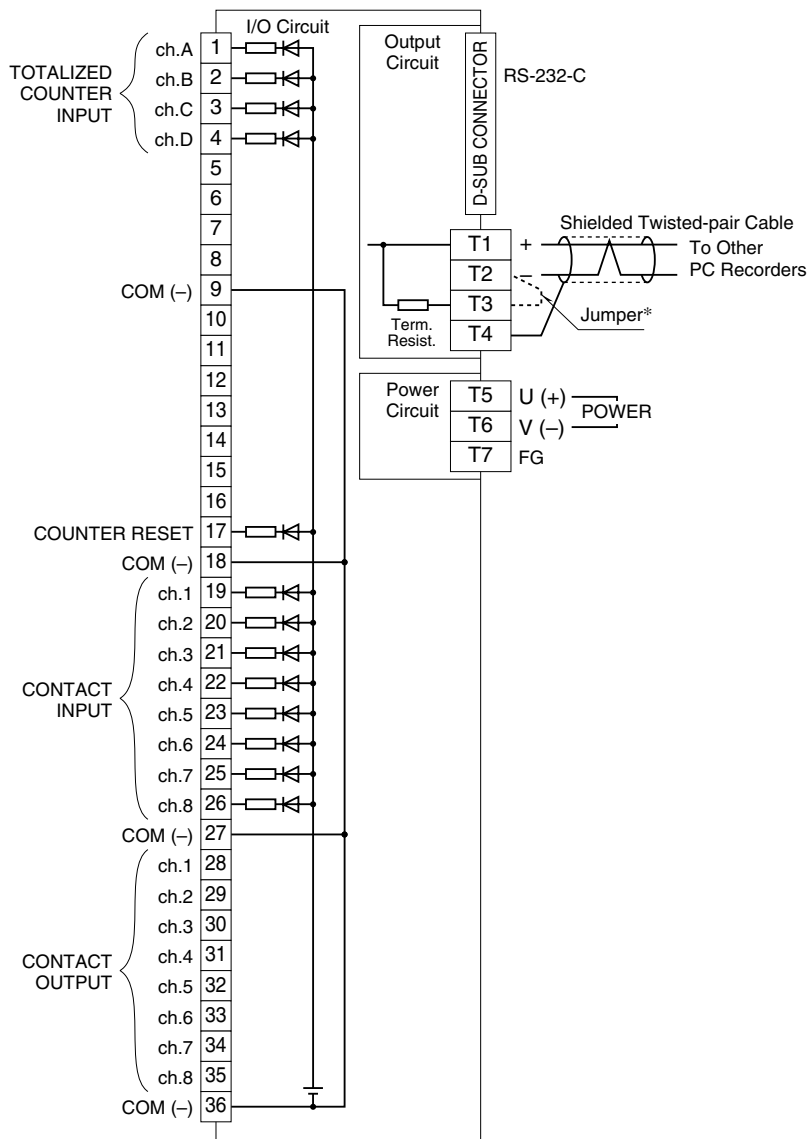

* When the device is located at the end of a transmission line via twisted-pair cable, (when there is no cross-wiring), close across the terminal T2 – T3 with the attached jumper pin (or with a leadwire).

When the device is not at the end, remove the jumper pin.

DO NOT CONNECT to the terminals 5 thr. 8 or 10 thr. 16. Wrong connection may cause failure of the device.

Caution: FG terminal is NOT a protective conductor terminal.

■ RS-232-C INTERFACE



ABBR.	PIN NO.	EXPLANATION OF FUNCTION
BA (SD)	2	Transmitted Data
BB (RD)	3	Received Data
AB (SG)	5	Signal Common
CB (CS)	7	Clear to Send
CA (RS)	8	Request to Send
	1	Not Used.
	4	DO NOT connect. Connecting may cause malfunctions.
	6	
	9	

WIRING INSTRUCTIONS

■ M3 SCREW TERMINAL (I/O signal)

Torque: 0.6 N·m

■ SOLDERLESS TERMINAL

Refer to the drawing below for recommended ring tongue terminal size. Spade tongue type is also applicable.

Applicable wire size: 0.75 to 1.25 mm² (AWG19 to 16)

Recommended manufacturer: Japan Solderless Terminal MFG.Co.Ltd, Nichifu Co.,ltd

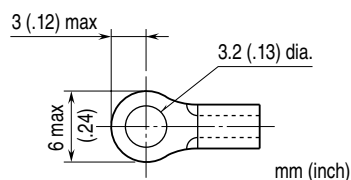

■ EURO TYPE CONNECTOR TERMINAL (Power input, Modbus)

Applicable wire size: 0.2 to 2.5 mm² (AWG24 to 12)

Stripped length: 7 mm

COMMUNICATION CABLE CONNECTIONS

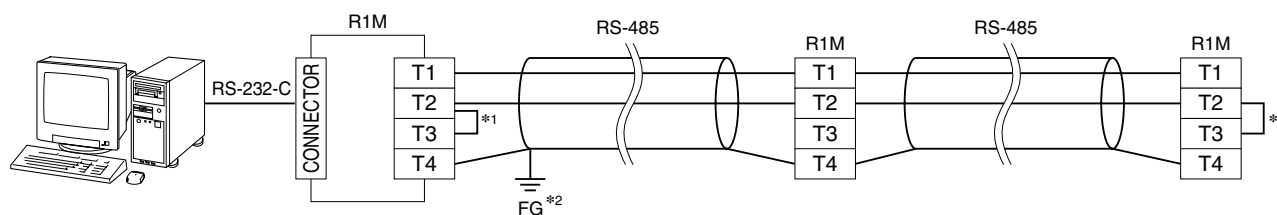

*1. Internal terminating resistor is used when the device is at the end of a transmission line.

*2. Install shielded cables to all sections and ground them at single point.

CHECKING

- 1) Terminal wiring: Check that all cables are correctly connected according to the connection diagram.
- 2) Power input: Check supply voltage.