

**CONTACT I/O MODULE****(4 totalized counter inputs, 8 contact inputs and outputs)**

MODEL

**R1M-P4****BEFORE USE ....**

Thank you for choosing M-System. Before use, please check contents of the package you received as outlined below.

If you have any problems or questions with the product, please contact M-System's Sales Office or representatives.

This product is for use in general industrial environments, therefore may not be suitable for applications which require higher level of safety (e.g. safety or accident prevention systems) or of reliability (e.g. vehicle control or combustion control systems).

For safety, installation and maintenance of this product must be conducted by qualified personnel.

**■ PACKAGE INCLUDES:**

Remote I/O module .....(1)

**■ MODEL NO.**

Confirm Model No. marking on the product to be exactly what you ordered.

**■ INSTRUCTION MANUAL**

This manual describes necessary points of caution when you use this product, including installation, connection and basic maintenance procedures.

For detailed information on Modbus supported functions, refer to Modbus Protocol Reference Guide (EM-5650).

The R1M is programmable using the PC configurator software. For detailed information on the PC configuration, refer to the R1CON instruction manual. The R1CON PC Configurator Software is downloadable at M-System's web site: <http://www.m-system.co.jp>.

**POINTS OF CAUTION****■ POWER INPUT RATING & OPERATIONAL RANGE**

- Locate the power input rating marked on the product and confirm its operational range as indicated below:  
100 – 240V AC rating: 85 – 264V, 47 – 66 Hz, approx. 10VA  
24V DC rating: 24V ±10%, approx. 7W

**■ GENERAL PRECAUTIONS**

- Before you remove the module, turn off the power supply, input signal and output signal for safety.

**■ ENVIRONMENT**

- Indoor use.
- When heavy dust or metal particles are present in the air, install the module inside proper housing with sufficient ventilation.
- Do not install the module where it is subjected to continuous vibration. Do not subject the unit to physical impact.
- Environmental temperature must be within -5 to +60°C (23 to 140°F) with relative humidity within 30 to 90% RH in order to ensure adequate life span and operation.
- Be sure that the ventilation slits are not covered with cables, etc.

**■ WIRING**

- Wrong connection may damage the module.
- Do not connect cables to moving parts or pull them tightly.
- Do not install cables close to noise sources (relay drive cable, high frequency line, etc.).
- Do not bind these cables together with those in which noises are present. Do not install them in the same duct.

**■ AND ....**

- The module is designed to function as soon as power is supplied, however, a warm up for 10 minutes is required for satisfying complete performance described in the data sheet.

## COMPONENT IDENTIFICATION

### ■ TOP VIEW

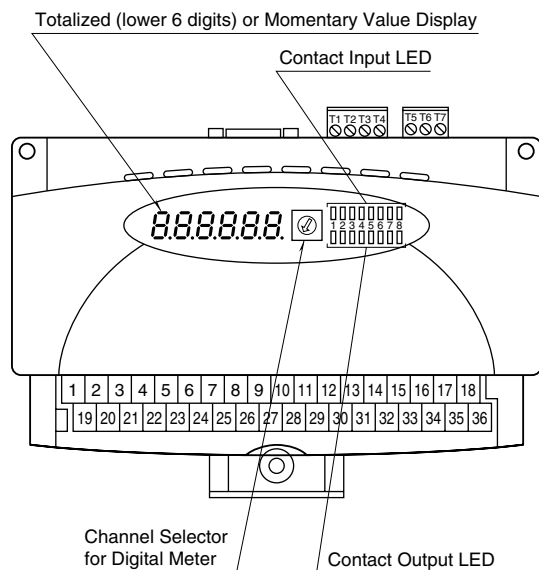

### ■ BOTTOM VIEW

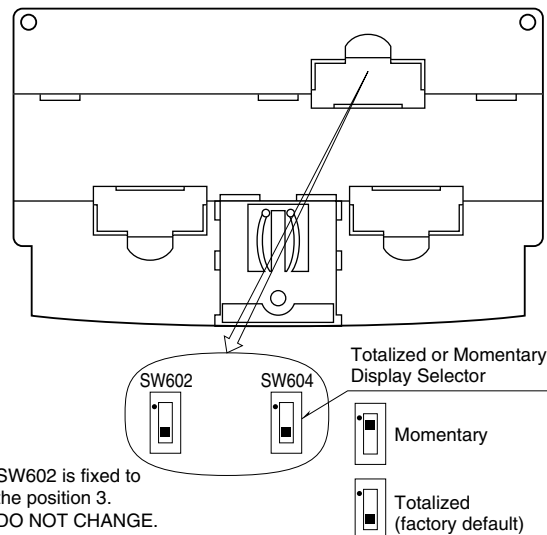

### ■ REAR VIEW

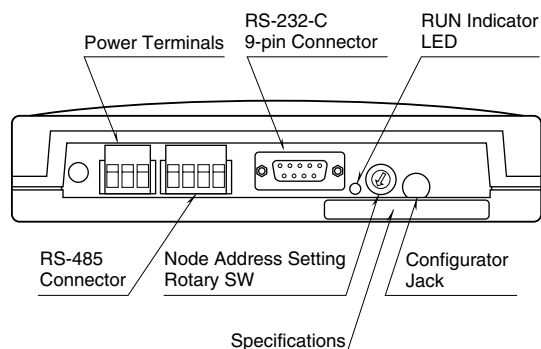

## INSTALLATION

### ■ DIN RAIL MOUNTING

Set the body so that its DIN rail adaptor is at the bottom. Pull down the DIN rail adaptor. Position the upper hook at the rear side on the DIN rail and push in the lower. Push back the DIN rail adaptor.

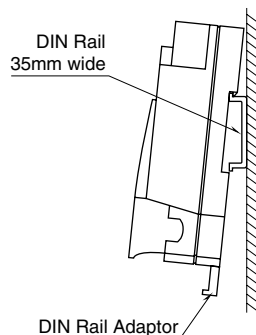

### ■ WALL MOUNTING

Set the body so that its DIN rail adaptor is at the bottom. Pull down the DIN rail adaptor. Refer to "EXTERNAL DIMENSIONS."

## TERMINAL CONNECTIONS

Connect the module referring to the connection diagram.

### EXTERNAL DIMENSIONS unit: mm (inch)

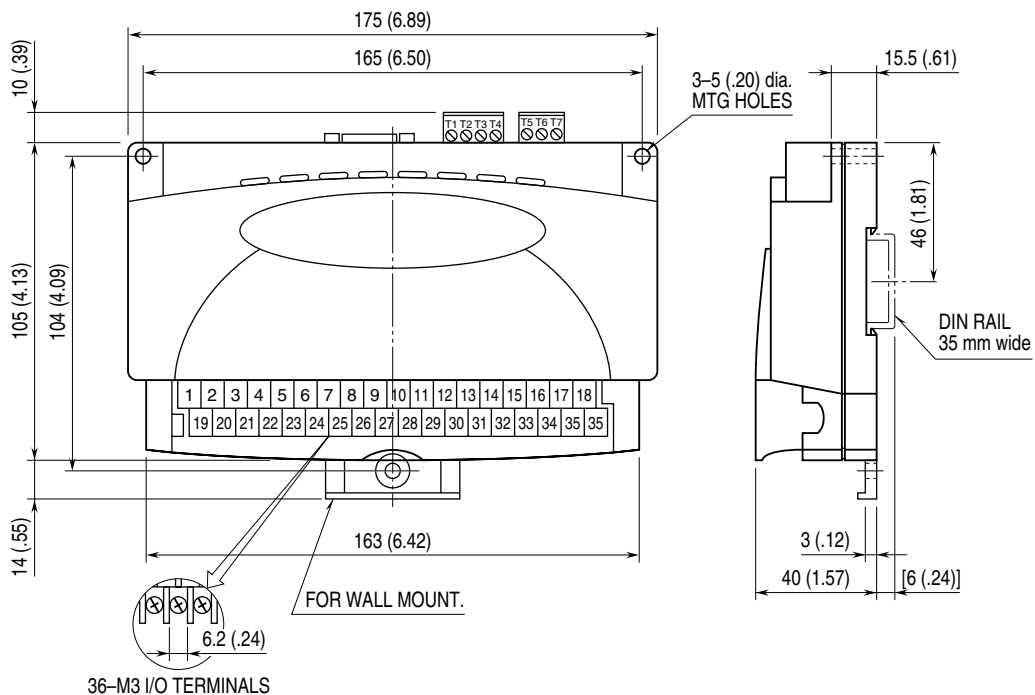

■ CONNECTION DIAGRAM

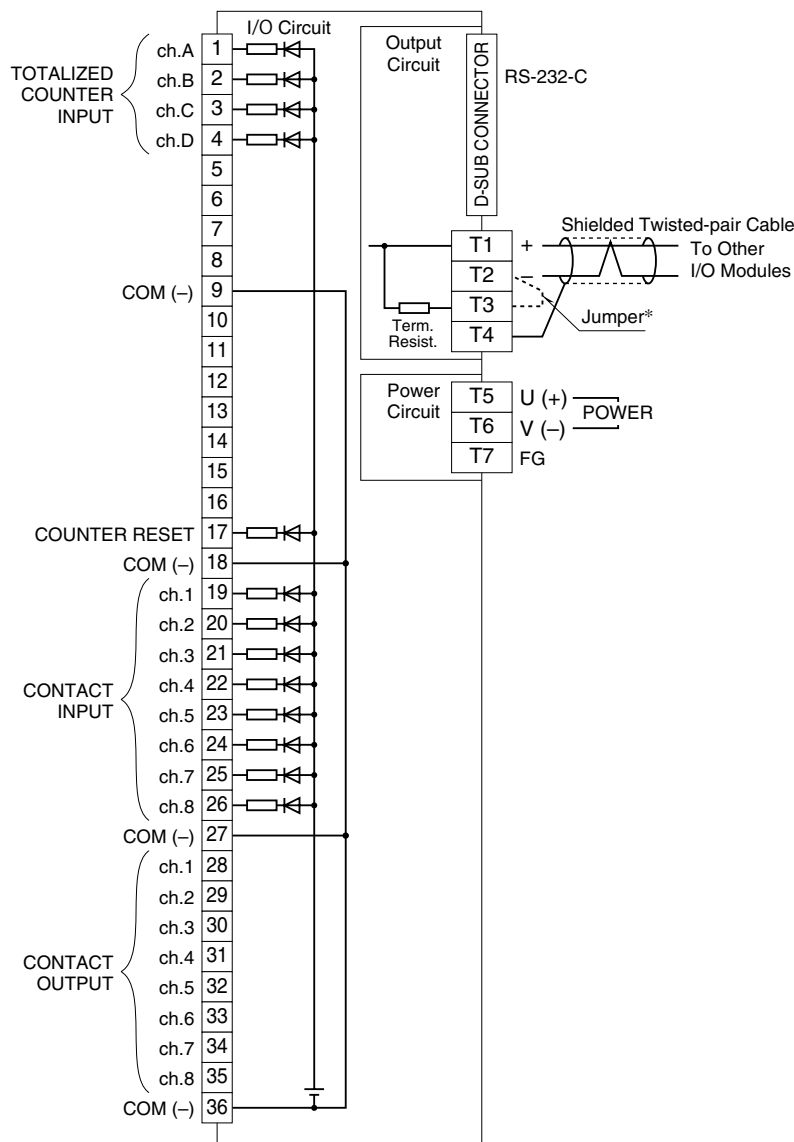

\* When the device is located at the end of a transmission line via twisted-pair cable, (when there is no cross-wiring), close across the terminal T2 – T3 with the attached jumper pin (or with a leadwire).  
When the device is not at the end, remove the jumper pin.

DO NOT CONNECT to the terminals 5 thr. 8 or 10 thr. 16.  
Wrong connection may cause failure of the device.

Caution: FG terminal is NOT a protective conductor terminal.

■ RS-232-C INTERFACE



ABBR.	PIN NO.	EXPLANATION OF FUNCTION
BA (SD)	2	Transmitted Data
BB (RD)	3	Received Data
AB (SG)	5	Signal Common
CB (CS)	7	Clear to Send
CA (RS)	8	Request to Send
	1	Not Used.
	4	DO NOT connect. Connecting may cause malfunctions.
	6	
	9	

## WIRING INSTRUCTIONS

### ■ M3 SCREW TERMINAL (I/O signal)

Torque: 0.6 N·m

### ■ SOLDERLESS TERMINAL

Refer to the drawing below for recommended ring tongue terminal size. Spade tongue type is also applicable.

Applicable wire size: 0.75 to 1.25 mm<sup>2</sup> (AWG19 – 16)

Recommended manufacturer: Japan Solderless Terminal MFG.Co.Ltd, Nichifu Co.,ltd

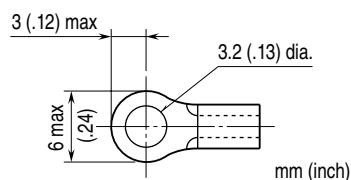

### ■ EURO TYPE CONNECTOR TERMINAL (Power input, Modbus)

Applicable wire size: 0.2 – 2.5 mm<sup>2</sup> (AWG24-12)

Stripped length: 7 mm

## MODBUS WIRING CONNECTION

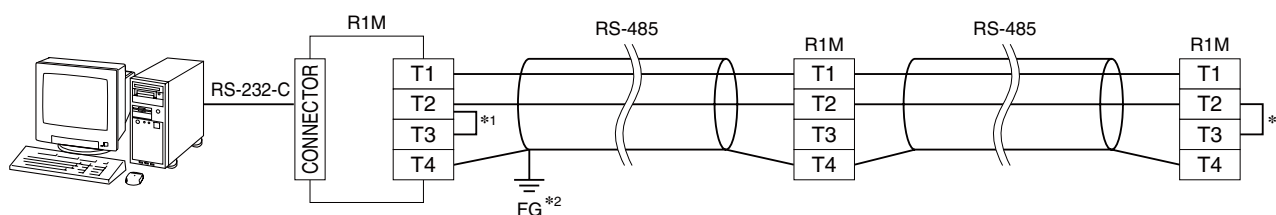

\*1. Internal terminating resistor is used when the device is at the end of a transmission line.

\*2. Install shielded cables to all sections and ground them at single point.

## MODBUS COMMUNICATION

### ■ COMMUNICATION PARAMETERS

PARAMETER	SPECIFICATION
Data Mode	RTU
Baud Rate	9600 / 19200 / 38400 (*) bps
Parity	None / Odd (*) / Even
Bit Length	8
Stop Bit	1 (*) / 2
Node Address	1 (*) to 15
Floating Point Data	N/A
Interface	RS-232-C / RS-485

### ■ FUNCTION CODES & SUPPORTED CODES

CODE	NAME		
01	Read Coil Status	X	Digital output from the slave
02	Read Input Status	X	Status of digital inputs to the slave
03	Read Holding Registers	X	General purpose register within the slave
04	Read Input Registers	X	Collected data from the field by the slave
05	Force Single Coil	X	Digital output from the slave
06	Preset Single Registers	X	General purpose register within the slave
07	Read Exception Status		
08	Diagnostics		
09	Program 484		
10	Poll 484		
11	Fetch Comm. Event Counter		Fetch a status word and an event counter
12	Fetch Comm. Event Log		A status word, an event counter, a message count and a field of event bytes
13	Program Controller		
14	Poll Controller		
15	Force Multiple Coils	X	Digital output from the slave
16	Preset Multiple Registers	X	General purpose register within the slave
17	Report Slave ID		Slave type / 'RUN' status
18	Program 884/M84		
19	Reset Comm. Link		
20	Read General Reference		
21	Write General Reference		
22	Mask Write 4X Register		
23	Read/Write 4X Register		
24	Read FIFO Queue		

## ■ DATA ADDRESS

	ADDRESS	DATA FORMAT	NAME
Coil (0X)	1 – 8	bit	DO
	49	bit	All counters reset
	50	bit	Pulse logic to count
Input Status (1X)	1 – 8	bit	DI
Input Register (3X)	1 – 16	UL	Totalized count (ch.1 – 8)
	17 – 24	UL	Totalized count (ch.A – D)
	33 – 40	UI	Momentary value (ch.1 – 8)
	41 – 44	UI	Momentary value (ch.A – D)
	513	I	System status
	514 – 521	B16	Model No. (“R1M-x”)
	522 – 529	B16	Serial No.
	530 – 537	B16	Hardware version No.
Holding Register (4X)	538 – 545	B16	Firmware version No.
	1 – 16	UL	Counter preset value (ch.1 – 8)
	17 – 24	UL	Counter preset value (ch.A – D)

bit = 1 bit, UL = 32-bit integer, I = signed 16-bit integer, UI = 16-bit integer, B16 = 16-byte character

## ■ INPUT DATA

- 32-bit Integer, No sign

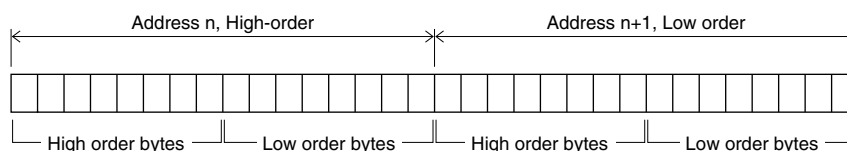

## CHECKING

- 1) Terminal wiring: Check that all cables are correctly connected according to the connection diagram.
- 2) Power input: Check supply voltage.

## ADJUSTMENT PROCEDURE

This unit is calibrated at the factory to meet the ordered specifications, therefore you usually do not need any calibration.