

Contents

1. BEFORE USE	2
2. GENERAL DESCRIPTION	3
3. POINTS OF CAUTION.....	3
4. HARDWARE SPECIFICATIONS	4
5. COMPONENT IDENTIFICATIONS	5
6. INSTALLATION	5
7. TERMINAL CONNECTIONS	6
7.1. EXTERNAL DIMENSIONS	6
7.2. CONNECTION DIAGRAM	7
8. INPUT RANGE SELECTING.....	8
9. CONNECTING DATA LINK WIRES.....	9
9.1. TWISTED-PAIR CABLE	9
9.2. POINTS OF CAUTION IN HANDLING WIRES	9
9.3. WIRING DIAGRAM	9
10. SELECTING CC-LINK VERSION.....	9
11. DATA LIST	10
11.1. REMOTE I/O	10
11.2. ASSIGNING REMOTE REGISTERS	10
11.3. A/D CONVERSION	10
12. PARAMETERS SETTING BY PLC PROGRAM	11
12.1. GENERAL DESCRIPTION	11
13. TROUBLESHOOTING.....	12
13.1. L ERR. INDICATOR BLINKING	12
13.2. L ERR. INDICATOR ON	12
13.3. L RUN INDICATOR OFF	12
13.4. UNABLE TO READ/WRITE DIGITAL VALUES?	12
14. CHECKING.....	13
15. ADJUSTMENT PROCEDURE.....	13
16. MAINTENANCE.....	13
17. LIGHTNING SURGE PROTECTION	13

1. BEFORE USE

Thank you for choosing M-System. Before use, please check contents of the package you received as outlined below.

If you have any problems or questions with the product, please contact M-System's Sales Office or representatives.

This product is for use in general industrial environments, therefore may not be suitable for applications which require higher level of safety (e.g. safety or accident prevention systems) or of reliability (e.g. vehicle control or combustion control systems).

For safety, installation and maintenance of this product must be conducted by qualified personnel.

■ PACKAGE INCLUDES:

Thermocouple & DC input module (body + CJC sensor)(1)
 Terminating resistor (110 Ω , 0.5 W).....(1)

■ MODEL NO.

Confirm Model No. marking on the product to be exactly what you ordered.

■ INSTRUCTION MANUAL

This manual describes necessary points of caution when you use this product, including installation, connection and basic maintenance procedures.

The R1C is programmable using the R1X Configurator Software (model: R1CON). For detailed information on the PC configuration, refer to the R1CON instruction manual. The R1CON PC Configurator Software is downloadable at M-System's web site: <https://www.m-system.co.jp>.

2. GENERAL DESCRIPTION

The model R1C-GH, Thermocouple & DC Input Module, is used as remote device for CC-Link. Model number and suffix codes are designated as follows:

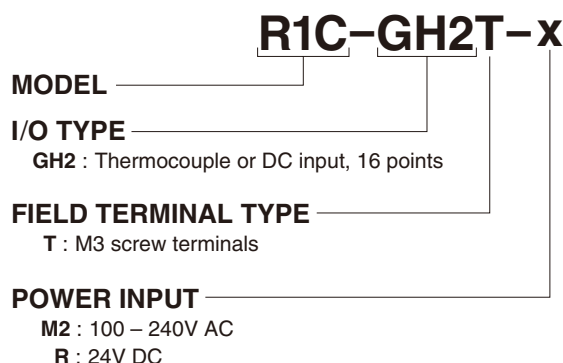

The R1C accepts 16 points of thermocouple and/or DC input signals. It converts analog inputs (0 – 100%) proportionally into 16-bit signed binary signals.

CC-Link Version 1.10 and 2.00 can be switched at the startup.

This instruction manual explains hardware specifications, component identification, and wiring instructions, etc.

3. POINTS OF CAUTION

■ GENERAL PRECAUTIONS

- Before you remove the module, turn off the power supply and input signal for safety.

■ ENVIRONMENT

- Indoor use.
- When heavy dust or metal particles are present in the air, install the module inside proper housing with sufficient ventilation.
- Do not install the module where it is subjected to continuous vibration. Do not subject the module to physical impact.
- Environmental temperature must be within -5 to +60°C (23 to 140°F) with relative humidity within 30 to 90% RH in order to ensure adequate life span and operation.
- Be sure that the ventilation slits are not covered with cables, etc.

■ WIRING

- Wrong connection may damage the module.
- Do not connect cables to moving parts or pull them tightly.
- Do not install cables close to noise sources (relay drive cable, high frequency line, etc.).
- Do not bind these cables together with those in which noises are present. Do not install them in the same duct.

■ AND

- The module is designed to function as soon as power is supplied, however, a warm up for 10 minutes is required for satisfying complete performance described in the data sheet.

4. HARDWARE SPECIFICATIONS

ITEM	SPECIFICATIONS				
Analog input	±20V DC, ±5V DC, ±0.8V DC, ±0.2V DC, ±50mV DC, ±10mV DC (input resistance 300 kΩ)				
Sampling rate	Approx. 150 msec. / 16 points				
Protocol	CC-Link, Ver.1.10 / Ver. 2.00				
Digital output	16-bit signed binary (14 bits for data)				
	Input Type	A/D Conversion Range (decimal)			
	±20V	±20000			
	±5V	±5000			
	±1V	±10000			
	±0.8V	±8000			
	±0.2V	±20000			
	±50mV	±5000			
	±10mV	±10000			
	Thermocouple	Temperature × 10			
Accuracy	DC Input	±0.3%			
	Thermocouple	T/C Type	Usable Range (°C)	Accuracy (%)	Conformance Range (°C)
		(PR)	0 to 1770	±0.5	400 to 1770
		K (CA)	-270 to +1370	±0.3	0 to 1370
		E (CRC)	-270 to +1000	±0.7	0 to 1000
		J (IC)	-210 to +1200	±0.7	0 to 1200
		T (CC)	-270 to +400	±1.0	0 to 400
		B (RH)	100 to 1820	±0.7	700 to 1820
		R	-50 to +1760	±0.7	400 to 1760
		S	-50 to +1760	±0.7	400 to 1760
		C (WRe 5-26)	0 to 2320	±0.7	0 to 2320
		N	-270 to +1300	±0.5	0 to 1300
		U	-200 to +600	±0.5	0 to 600
	L	-200 to +900	±0.3	0 to 900	
	P (Platinel II)	0 to 1395	±0.5	0 to 1395	
CJC error	≤ ±3°C at 20°C ±10°C				
Number of inputs	16				
Isolation	Input to CC-Link (FG) to power				
Required nodes	CC-Link Ver. 1.10 4 (RX/R Y 32 points each, RW _r /RW _w each 16 points) CC-Link Ver. 2.00 1 (RX/R Y 64 points each, RW _r /RW _w each 16 points)				
Power input, CC-Link	Euro type connector terminal (applicable wire size: 0.2 to 2.5 mm ² (AWG 24 to 12), stripped length 7 mm)				
Input	M3 screw terminals (torque: 0.6 N·m)				
Configurator	2.5 dia. miniature jack; RS-232-C level				
Noise immunity	1000 V _{p-p} , 1 μsec.				
Dielectric strength	2000V AC @ 1 minute (input to CC-Link [FG] to power to ground [FG1])				
Insulation resistance	≥100 MΩ with 500V DC (input to CC-Link [FG] to power)				
Weight	400 g (0.88 lb)				
Power input	R1C-GH2T-M2	85 – 264V AC, 47 – 66 Hz			
	R1C-GH2T-R	24V DC ±10%			
Power consumption	R1C-GH2T-M2	Approx. 10VA			
	R1C-GH2T-R	Approx. 7W			

5. COMPONENT IDENTIFICATIONS

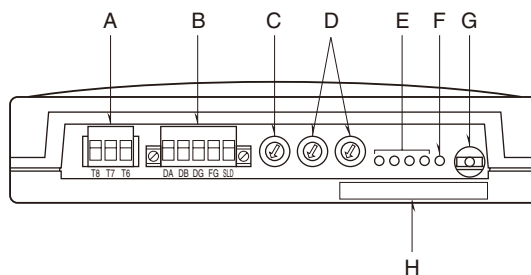

NAME	FUNCTIONS		
A	Power terminal block	For power input	
B	Network terminal block	For wiring to CC-Link	
C	Baud rate setting	SETTING	BAUD RATE
		0	156 kbps (factory default)
		1	625 kbps
		2	2.5 Mbps
		3	5 Mbps
4	10 Mbps		
Other than 0 – 4	Not valid; L ERR. turns on as a transmission error.		
D	Station No. setting	Ver. 1.10: Selectable within 1 – 61. (factory set to: 00)	
		Ver. 2.00: Selectable within 1 – 64. (factory set to: 00)	
E	Status indicator LED	ID (color)	FUNCTIONS
		L RUN (red)	ON: Normal communication OFF: Communication down (time-out error)
		L ERR. (red)	ON : Transmission data error Blinking : Transmission data error OFF: Normal transmission
		SD (red)	ON when transmitting
		RD (red)	ON when receiving
F	Power LED	ID (color)	FUNCTIONS
		PWR (green)	ON: Blinking, high speed: Abnormality Blinking, low speed: CC-Link Ver. 1.10 CC-Link Ver. 2.00 Master Version 2.00 with long ON time Master Version 1.10 with long OFF time
G	Configurator jack	2.5 dia. miniature jack; RS-232-C level	
H	Specifications	Display(s) serial No., model No., etc.	

6. INSTALLATION

■ DIN RAIL MOUNTING

Set the body so that its DIN rail adaptor is at the bottom. Pull down the DIN rail adaptor.

Position the upper hook at the rear side on the DIN rail and push in the lower. Push back the DIN rail adaptor.

■ WALL MOUNTING

Set the body so that its DIN rail adaptor is at the bottom. Pull down the DIN rail adaptor.

Refer to “EXTERNAL DIMENSIONS.”

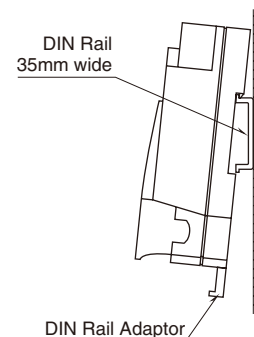

7. TERMINAL CONNECTIONS

Connect the module referring to the connection diagram.

Attach the CJC sensor together with input wiring to the input screw terminals. The sensor is calibrated for the particular module and not interchangeable with another. Check the serial numbers of the module and sensor.

7.1. EXTERNAL DIMENSIONS

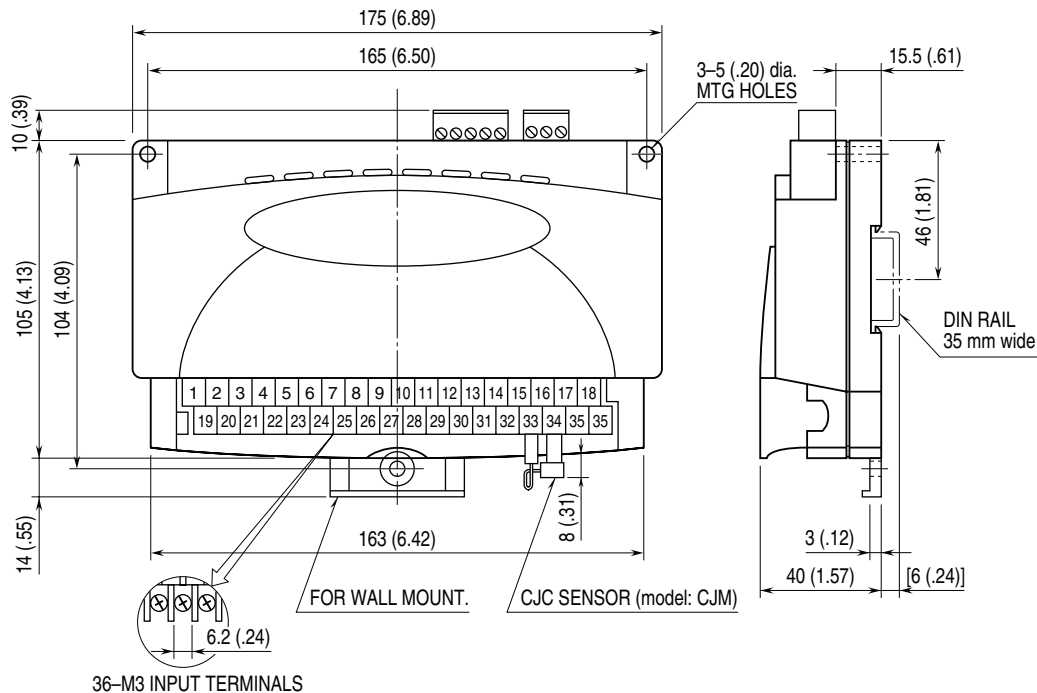

unit: mm (inch)

7.2. CONNECTION DIAGRAM

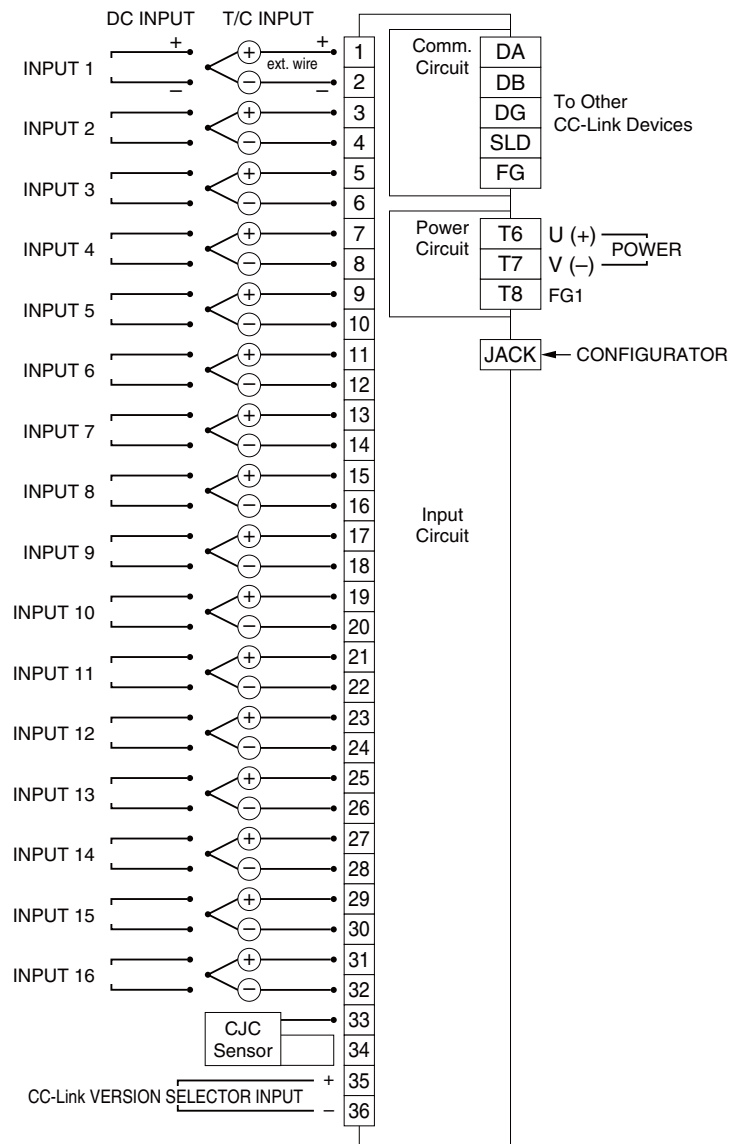



- Note 1: This device is not designed to cancel noise included in the input signals.
Be careful to eliminate such noise by using shielded cables.
- Note 2: Be sure to maintain the same potential at all the common negative terminals for DC input.
- Note 3: CC-Link version selector input is valid only at the moment of the power turned on.
Firmware version 0B.00 or higher. Use the R1X Configurator Software (model: R1CON)
or consult M-System to confirm the firmware version.
- Caution: FG1 terminal is NOT a protective conductor terminal.

8. INPUT RANGE SELECTING

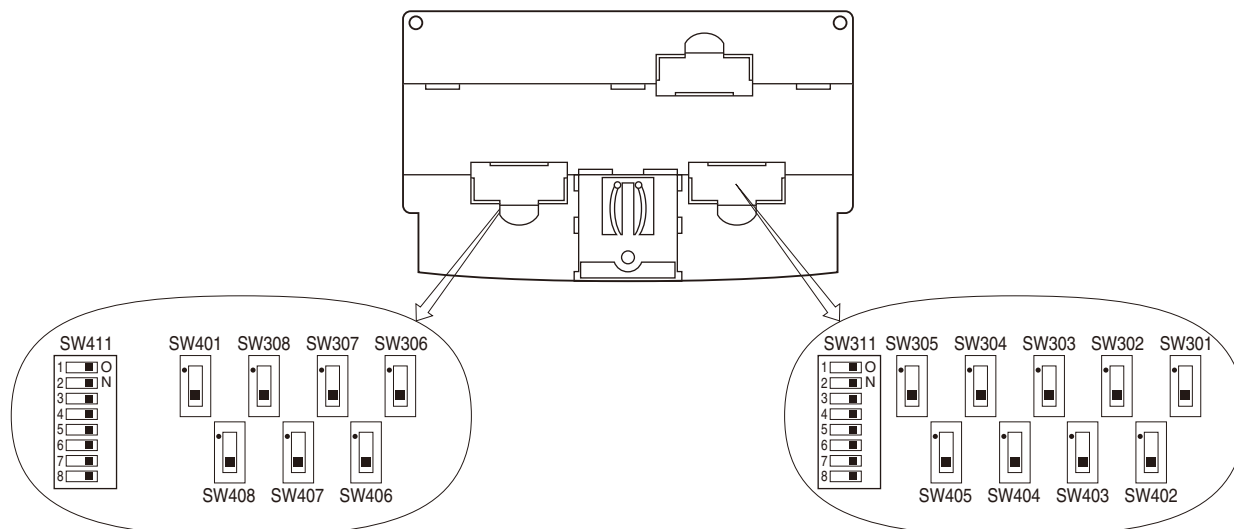
Select switches to match the input signal according to the table below. For fine range setting, the R1X Configurator Software (model: R1CON) including a dedicated cable is required.



INPUT	SWITCHES	SETTING	NOTES
Thermocouple	SW301 – SW308 (ch 1 – ch 8) SW401 – SW408 (ch 9 – ch 16)	Set to position “1” 	Attenuation OFF
	SW311 (ch 1 – ch 8) SW411 (ch 9 – ch 16)	OFF	
Voltage input, 0.8V or less	SW301 – SW308 (ch 1 – ch 8) SW401 – SW408 (ch 9 – ch 16)	Set to position “1” 	Attenuation OFF
	SW311 (ch 1 – ch 8) SW411 (ch 9 – ch 16)	ON	
Voltage input, above 0.8V (*)	SW301 – SW308 (ch 1 – ch 8) SW401 – SW408 (ch 9 – ch 16)	Set to position “3” 	Attenuation ON
	SW311 (ch 1 – ch 8) SW411 (ch 9 – ch 16)	ON	

(*) Factory setting unless specific input types and ranges are specified when ordering

9. CONNECTING DATA LINK WIRES

The following explanations apply to the wires connecting the R1C to the Master Unit.

9.1. TWISTED-PAIR CABLE

The following types of wire are recommended for connecting the R1C to the Master Unit.

KURAMO ELECTRIC FANC-SB 0.5 mm² × 3 or equivalent

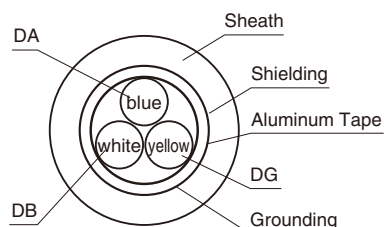

9.2. POINTS OF CAUTION IN HANDLING WIRES

DO NOT apply extraordinary forces to the wires as explained in the following:

- 1) DO NOT SQUEEZE the wires with a sharp-edged tool.
- 2) DO NOT TWIST the wires extraordinarily.
- 3) DO NOT PULL the wires extraordinarily tight.
- 4) DO NOT TRAMPLE on the wires.
- 5) DO NOT PUT objects onto the wires.
- 6) DO NOT DAMAGE the insulation tube of wires.

9.3. WIRING DIAGRAM

Connect the R1C to the Master Unit as shown below.

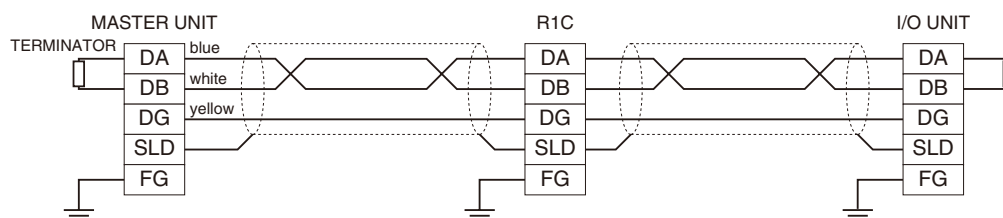

10. SELECTING CC-LINK VERSION

The R1C-GH is usable both for CC-Link Ver. 1.10 and Ver. 2.00. The contact status of the version selector input at the moment of the power supplied determines the CC-Link version. Required node numbers depends upon the version No as shown below. For use with Ver. 2.00, set the cyclic expansion to '4' at the Master Unit.

VERSION SELECTOR INPUT	CC-LINK VERSION	REQUIRED NODES	SELECTABLE STATION NO.
ON	Ver. 2.00	1	1 through 64
OFF	Ver. 1.10	4	1 through 61

11. DATA LIST

11.1. REMOTE I/O

For CC-Link Ver.1.10, the R1C occupies 4 nodes according to the number of I/O channels, for CC-Link Ver.2.00, it occupies 1 node. Regardless of the number of nodes, for CC-Link Ver.1.10, 32 bits are assigned to each of input and output for sending to/receiving from the Master Unit, for CC-Link Ver.2.00, 64 bits are assigned. One (1) bit among RXxB* is used as remote device (R1C) READY signal, turned ON when the R1C is in normal operation.

- **CC-Link Ver.1.10**

*x = (Station No. × 2 – 1) H

[example] Station No. = 9

$$9 \times 2 - 1 = 17 \Rightarrow 11\text{H}$$

READY signal is input at RX11B.

- **CC-Link Ver.2.00**

*x = (Station No. × 4 – 1) H

[example] Station No. = 9

$$9 \times 4 - 1 = 35 \Rightarrow 23\text{H}$$

READY signal is input at RX23B.

11.2. ASSIGNING REMOTE REGISTERS

The R1C does not use the remote registers for the direction from the Master to Remote (RWwn to RWwn+15). The table below shows the data assignment of those for the direction from the Remote to Master.

DIRECTION	ADDRESS	CONTENTS	DEFAULT
R1C ↓ Master	RWrn + 0	Ch. 1 digital output	0
	RWrn + 1	Ch. 2 digital output	0
	RWrn + 2	Ch. 3 digital output	0
	RWrn + 3	Ch. 4 digital output	0
	RWrn + 4	Ch. 5 digital output	0
	RWrn + 5	Ch. 6 digital output	0
	RWrn + 6	Ch. 7 digital output	0
	RWrn + 7	Ch. 8 digital output	0
	RWrn + 8	Ch. 9 digital output	0
	RWrn + 9	Ch. 10 digital output	0
	RWrn + 10	Ch. 11 digital output	0
	RWrn + 11	Ch. 12 digital output	0
	RWrn + 12	Ch. 13 digital output	0
	RWrn + 13	Ch. 14 digital output	0
	RWrn + 14	Ch. 15 digital output	0
	RWrn + 15	Ch. 16 digital output	0

11.3. A/D CONVERSION

1) OUTPUT IN NORMAL CONDITIONS

Analog input signal (0 – 100%) from signal conditioners is converted proportionally into digital data, provided to the Master Unit.

2) OUTPUT IN AN ABNORMALITY

When an abnormality such like CPU error, STOP, time-out occurs at the PLC, the output signal of the R1C is maintained as HOLD (no clearing output signal, keeping the value just before the abnormality).

When the PLC recovers to normal operation and the R1C receives new data, the output restarts changing.

12. PARAMETERS SETTING BY PLC PROGRAM

12.1. GENERAL DESCRIPTION

The ladder diagram below shows a program example assuming that the master station's first I/O number is X/Y20 to 3F.

For detailed information, refer to users manuals for the PLC CPU and the Master Unit.

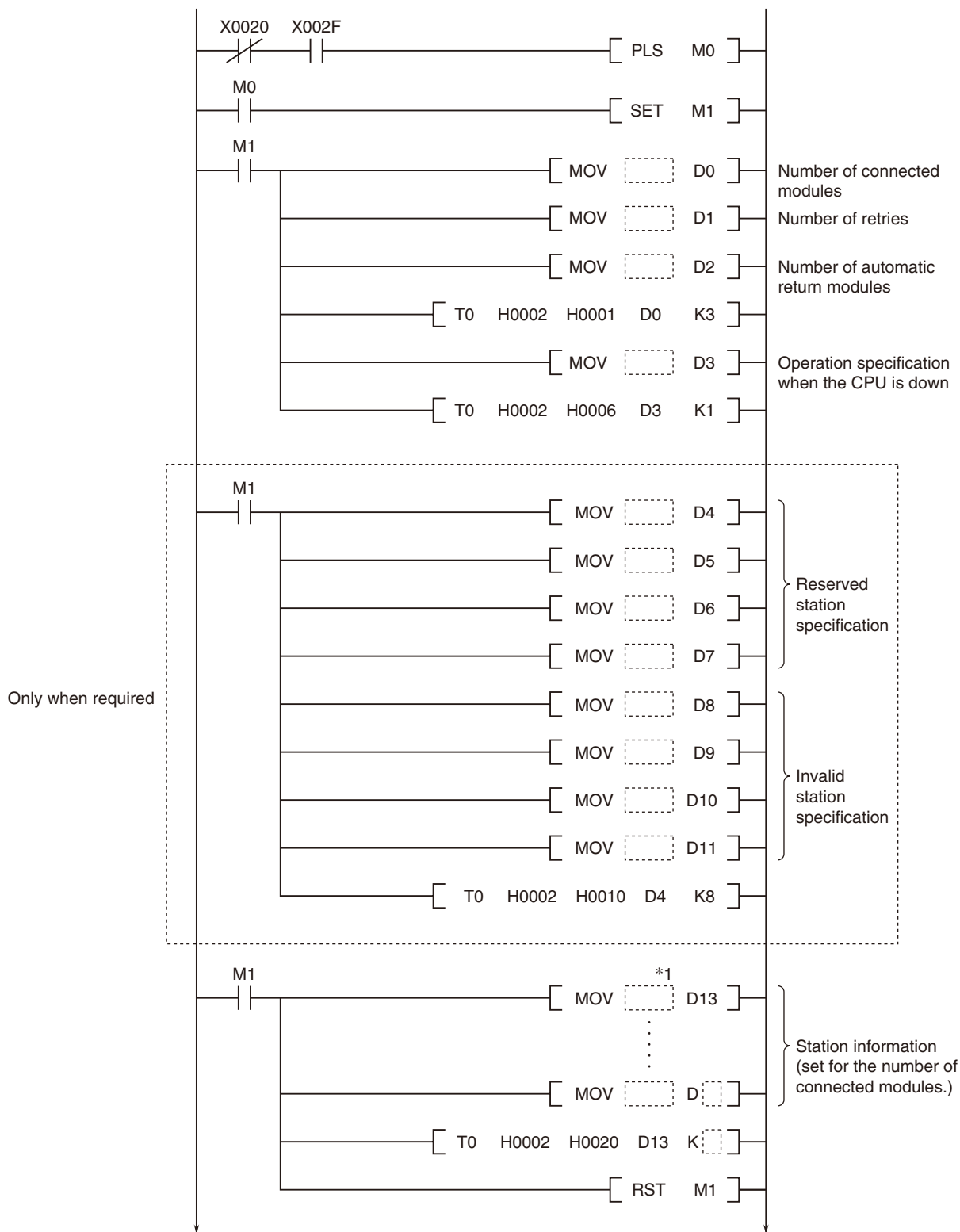

*1. 14xx
where xx = R1C Station No.

13. TROUBLESHOOTING

Basic troubleshooting methods are explained in this section.

For problems concerning the PLC CPU and Master Unit, consult users manuals for these units.

13.1. L ERR. INDICATOR BLINKING

CHECK	TROUBLESHOOTING
Have you changed the station No. and/or baud rate settings during normal operation?	Return these settings to the state when the unit operated normally.

13.2. L ERR. INDICATOR ON

CHECK	TROUBLESHOOTING
Are the station No. and/or baud rate settings correct?	Set them correctly.

13.3. L RUN INDICATOR OFF

Consult the users manual for the Master Unit.

13.4. UNABLE TO READ/WRITE DIGITAL VALUES?

CHECK	TROUBLESHOOTING
Is the L RUN indicator OFF?	Refer to Section "13.3. L RUN INDICATOR OFF".
Is the L ERR. indicator blinking or ON?	Consult the users manual for the Master Unit.
Is the RUN indicator on the PLC CPU blinking or OFF?	Consult the users manual for the CPU.
Is the RUN indicator on the Master Unit OFF?	Consult the users manual for the Master Unit.
Are the RD/SD indicators on the Master Unit ON?	Consult the users manual for the Master Unit.
Are the wires for analog I/O properly connected to respective terminals? No wire breakdown?	Check these wires visually or check conductivity for each pair of wires.
Remove analog input wires and apply test voltage to the terminals (e.g. Use a dry cell). Try to read out digital value.	If the digital value is read out normally, there are possibilities of noise interference via external wires. Check wiring and grounding.

14. CHECKING

- 1)Terminal wiring: Check that all cables are correctly connected according to the connection diagram.
- 2)Power input: Check supply voltage across the terminals T6 – T7.
- 3)Input: Check that the input is within 0 – 100% of full-scale.
- 4)DIP SW setting: Check that all switches are set correctly.

15. ADJUSTMENT PROCEDURE

This unit is calibrated at the factory to meet the ordered specifications, therefore you usually do not need any calibration.

16. MAINTENANCE

Regular calibration procedure is explained below:

■ CALIBRATION

Warm up the module for at least 10 minutes. Apply 0%, 25%, 50%, 75% and 100% input signal. Check that the A/D conversion data for the respective input signal remains within accuracy described in the data sheet. When the A/D conversion data is out of tolerance, contact Factory or M-System's local representative.

17. LIGHTNING SURGE PROTECTION

M-System offers a series of lightning surge protector for protection against induced lightning surges. Please contact M-System to choose appropriate models.