

Remote I/O R8 Series

PNP DISCRETE INPUT MODULE, 16 points

(Tension clamp terminal block)

Functions & Features

- 16 channels for discrete input, compact size remote I/O module
- 18 pins tension clamp connector

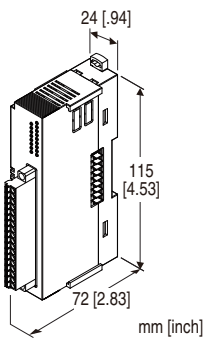

MODEL: R8-DAT16B2[1]

ORDERING INFORMATION

- Code number: R8-DAT16B2[1]
Specify a code from below for [1].
(e.g. R8-DAT16B2/Q)
- Specify the specification for option code /Q
(e.g. /C01)

[1] OPTIONS

blank: none

/Q: With options (specify the specification)

SPECIFICATIONS OF OPTION: Q

COATING (For the detail, refer to M-System's web site.)

/C01: Silicone coating

/C02: Polyurethane coating

RELATED PRODUCTS

- PC configurator software (model: R8CFG)
Downloadable at M-System's web site.
A dedicated cable is required to connect the module to the PC. Please refer to the internet software download site or the users manual for the PC configurator for applicable cable types.

GENERAL SPECIFICATIONS

Connection

- **Input:** Tension clamp
- **Excitation supply, internal bus:**
Connected to internal bus connector
- **Internal power:** Via bus connector

Isolation: Input or exc. supply to internal bus or internal power

Module address: With DIP switch

Terminating resistor: Built-in (DIP Switch, default: disable)

Status indicator: Bi-color (red/green) LED; Refer to the instruction manual.

Discrete input status indicators: Green LED; Refer to the instruction manual.

INPUT SPECIFICATIONS

Common: Negative common (NPN)

Number of input: 16 points

Maximum inputs applicable at once: No limit (at 24 V DC)

Rated input voltage: 24 V DC $\pm 10\%$; ripple 5 %p-p max.

ON voltage / current: ≥ 15 V DC (input - GND) / ≥ 2.3 mA

OFF voltage / current: ≤ 5 V DC (input - GND) / ≤ 1 mA

Input current: ≤ 4.5 mA per point at 24 V DC

Input resistance: Approx. 5.7 k Ω

ON delay: ≤ 2.0 msec.

OFF delay: ≤ 2.0 msec.

INSTALLATION

Max. current consumption: 100 mA

Operating temperature: -10 to +55°C (14 to 131°F)

Operating humidity: 30 to 90 %RH (non-condensing)

Atmosphere: No corrosive gas or heavy dust

Mounting: DIN rail

Weight: 110 g (0.24 lb)

PERFORMANCE

Data allocation: 1

Module addresses in use: 1

Power output (input connector): Rated current 3 A DC (rated current 3 A for internal fuse (slow blow fuse i^2t (A²sec.) max. 5.04)

Insulation resistance: ≥ 100 M Ω with 500 V DC

Dielectric strength: 1500 V AC @ 1 minute
(input or exc. supply to internal bus or internal power to ground)

STANDARDS & APPROVALS

EU conformity:

EMC Directive

EMI EN 61000-6-4

EMS EN 61000-6-2
RoHS Directive

EXTERNAL VIEW

FRONT VIEW

SIDE VIEW

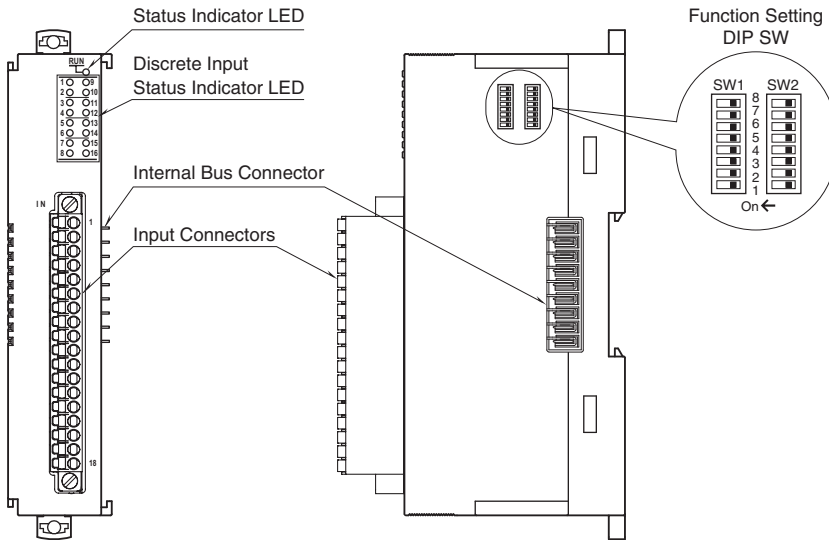

CONNECTION DIAGRAMS

■ Tension clamp terminal block

Unit side connector: MC1,5/18-GF-3,5

(Phoenix Contact)

Cable side connector: FMC1,5/18-STF-3,5 (Phoenix Contact)

Applicable wire size: 0.2 – 1.5 mm²

Stripped length: 10 mm

Recommended solderless terminal

- AI0,25–10YE 0.25 mm² (Phoenix Contact)
- AI0,34–10TQ 0.34 mm² (Phoenix Contact)
- AI0,5–10WH 0.5 mm² (Phoenix Contact)
- AI0,75–10GY 0.75 mm² (Phoenix Contact)
- A1–10 1.0 mm² (Phoenix Contact)
- A1,5–10 1.5 mm² (Phoenix Contact)

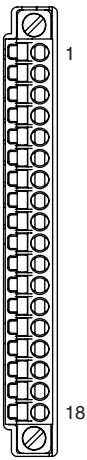

PIN No.	ID	FUNCTION
1	Di1	Input 1
2	Di2	Input 2
3	Di3	Input 3
4	Di4	Input 4
5	Di5	Input 5
6	Di6	Input 6
7	Di7	Input 7
8	Di8	Input 8
9	Di9	Input 9
10	Di10	Input 10
11	Di11	Input 11
12	Di12	Input 12
13	Di13	Input 13
14	Di14	Input 14
15	Di15	Input 15
16	Di16	Input 16
17	0V	Excitation supply 0V
18	24V	Excitation supply 24V

OPERATING MODE SETTING

(*) Factory default

Note: Be sure to set unused SW 2-1 through 2-5, 2-7 and 2-8 to OFF

■ Module Address (SW1)

SW1-1 through 1-4 determine the tenth place digit, while SW1-5 through 1-8 do the ones place digit of the module address.

Address is selected between 0 to 31.

(Factory setting: 0)

MODULE ADDRESS	SW1				
	×10 ×1	1 5	2 6	3 7	4 8
0		OFF	OFF	OFF	OFF
1		OFF	OFF	OFF	ON
2		OFF	OFF	ON	OFF
3		OFF	OFF	ON	ON
4		OFF	ON	OFF	OFF
5		OFF	ON	OFF	ON
6		OFF	ON	ON	OFF
7		OFF	ON	ON	ON
8		ON	OFF	OFF	OFF
9		ON	OFF	OFF	ON

■ Terminator DIP SW (SW2)

TERMINATOR SW	SW2-6
Without (*)	OFF
With	ON

EXTERNAL DIMENSIONS unit: mm [inch]

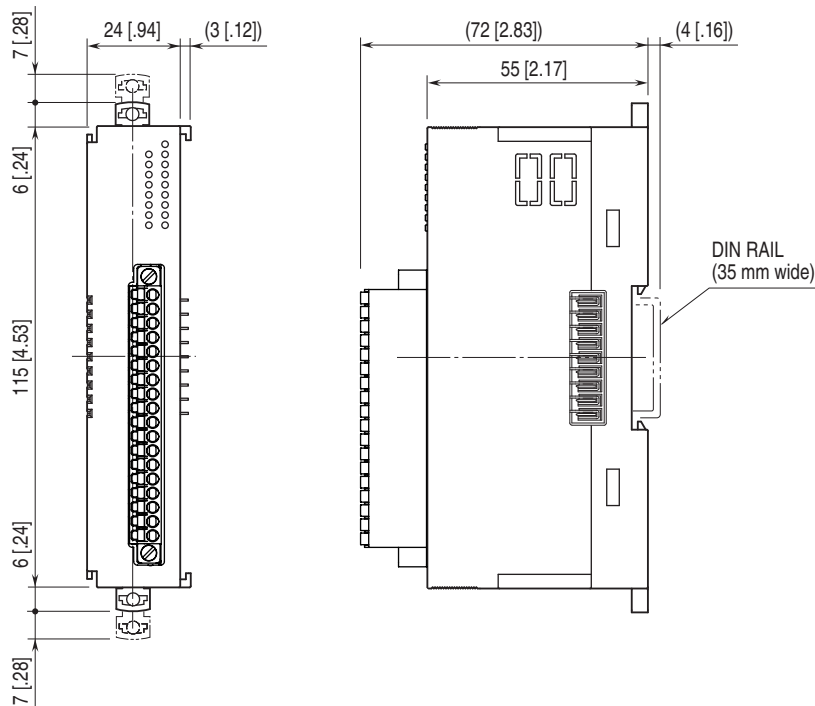

SCHEMATIC CIRCUITRY & CONNECTION DIAGRAM

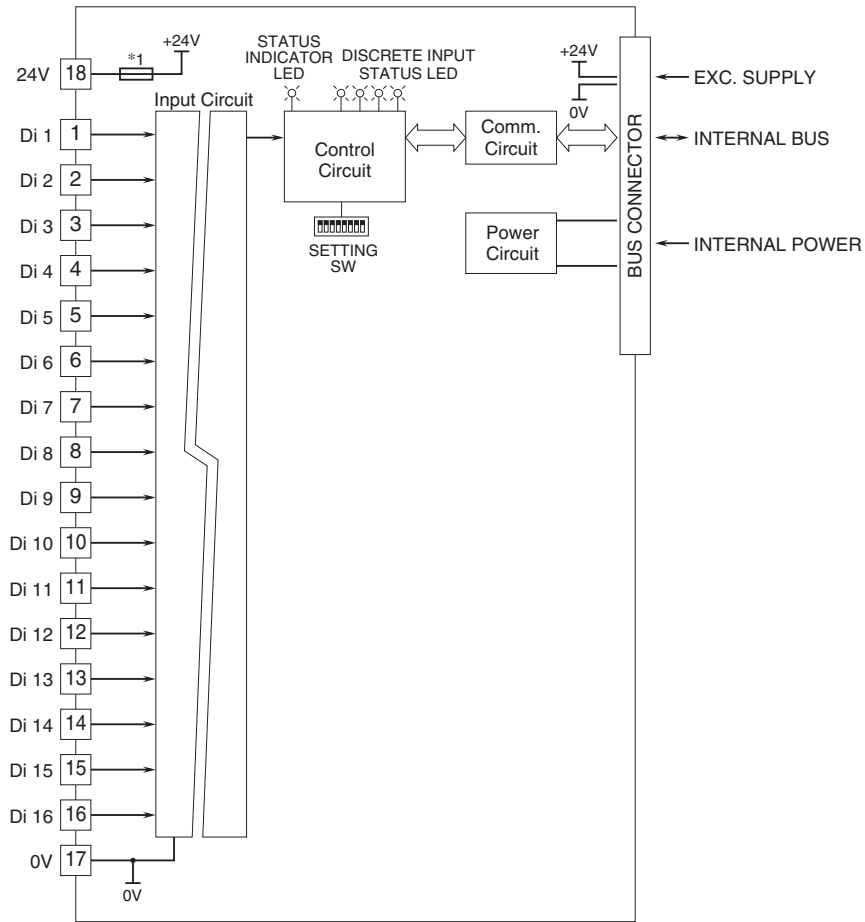

*1. Fuse is not replaceable.

INPUT CIRCUIT

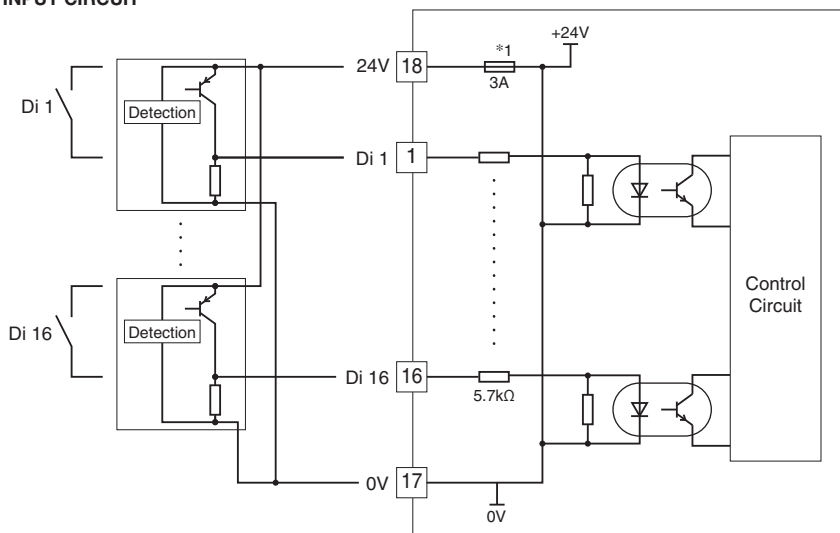

Specifications are subject to change without notice.