

Remote I/O R8 Series

depends upon the system configuration.

AC CURRENT INPUT MODULE

(RMS sensing, clamp-on current sensor, non-isolated, 4 points)

Functions & Features

- Clamp-on current sensor input, compact size remote I/O module
- Configurable with PC configurator (model: R8CFG)

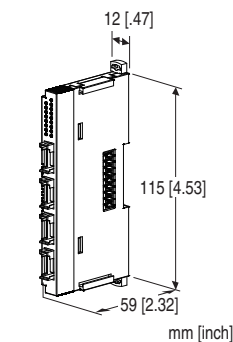

MODEL: R8-CT4E[1]

ORDERING INFORMATION

- Code number: R8-CT4E[1]
- Specify a code from below for [1].
(e.g. R8-CT4E/Q)
- Specify the specification for option code /Q
(e.g. /C01)

[1] OPTIONS

blank: none

/Q: With options (specify the specification)

SPECIFICATIONS OF OPTION: Q

COATING (For the detail, refer to M-System's web site.)

/C01: Silicone coating

/C02: Polyurethane coating

RELATED PRODUCTS

- PC configurator software (model: R8CFG)
Downloadable at M-System's web site.
A dedicated cable is required to connect the module to the PC. Please refer to the internet software download site or the users manual for the PC configurator for applicable cable types.
- Clamp-on current sensor (model: CLSE)
The clamp-on current sensors, not included in this product package, must be ordered separately. Required number

GENERAL SPECIFICATIONS

Connection

- **Input:** 4-pin e-CON connector

Unit side connector XN2D-1474-S002 (Omron)

Recommended cable side connector XN2A-1470 (Omron)

Applicable wire size: 0.08 - 0.5 mm² (AWG28 - 20)

Outer sheath diameter: max. 1.5 dia

(The cable connector is not included in the package.

Refer to the specifications of the product.)

- **Excitation supply, internal bus:**

Connected to internal bus connector

- **Internal power:** Supplied from internal bus connector

Isolation: Input to exc. supply to internal bus or internal power

Input waveform

RMS sensing: Up to 15 % of 3rd harmonic content

Clamp-on current sensor: DIP switch on side panel or with PC

Low-end cutout value setting: Settable range: 0.0 - 5.0 %.

(Configure with PC. The converted data not exceed the

setting value is forced 0 %. Factory setting: 1.0 %)

Module address: With rotary switch

Terminating resistor: Built-in (DIP Switch, default: disable)

Configuration mode: With DIP switches on the side panel

Status indicator: Bi-color (red/green) LED; Refer to the instruction manual.

Input status indicators: Red LED; Refer to the instruction manual.

INPUT

- **Clamp-on current sensor (CT1,CT2, CT3, CT4)**

(Sensor model No.: Input range)

CLSE-R5: 0 - 5 A

CLSE-05: 0 - 50 A

CLSE-10: 0 - 100 A

CLSE-20: 0 - 200 A

CLSE-40: 0 - 400 A

CLSE-60: 0 - 600 A

Frequency: 50 / 60 Hz (45 - 65 Hz)

Operational range: 0 - 105 % of rating

Overload capacity:

CLSE-R5: 10 A continuous

CLSE-05: 60 A continuous

CLSE-10: 120 A continuous

CLSE-20: 240 A continuous

CLSE-40: 480 A continuous

CLSE-60: 720 A continuous

Be sure that the input voltage is of 480 V or less.

INSTALLATION

Max. current consumption: 100 mA
Operating temperature: -10 to +55°C (14 to 131°F)
Operating humidity: 30 to 90 %RH (non-condensing)
Atmosphere: No corrosive gas or heavy dust
Mounting: DIN rail
Weight: 65 g (2.3 oz)

PERFORMANCE

Conversion accuracy: ± 1 % except the sensor accuracy
Conversion rate: 14 msec.
Conversion data: Integer that engineering unit value (A) multiplied by 100 (for CLSE-R5, integer that engineering unit value (A) multiplied by 1000).
 (Scaling of converted data is configurable with the configurator software)
Data allocation: 2
Module addresses in use: 2
Temp. coefficient: ± 0.03 %/°C (± 0.02 %/°F)
Response time: ≤ 0.5 sec. (0 - 90 %)
Insulation resistance: ≥ 100 M Ω with 500 V DC
Dielectric strength:
 1000 V AC @ 1 minute (input to exc. supply to internal bus or internal power to ground)

STANDARDS & APPROVALS

EU conformity:
 EMC Directive
 EMI EN 61000-6-4
 EMS EN 61000-6-2
 RoHS Directive

EXTERNAL VIEW

FRONT VIEW

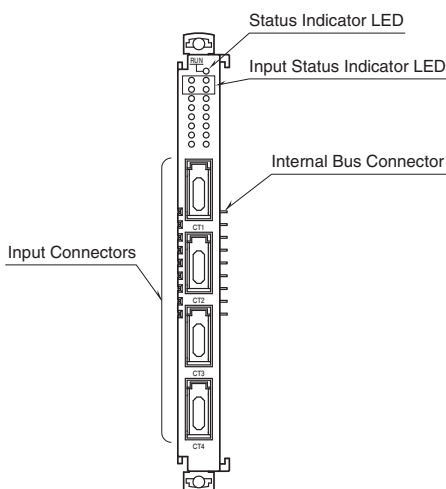

SIDE VIEW

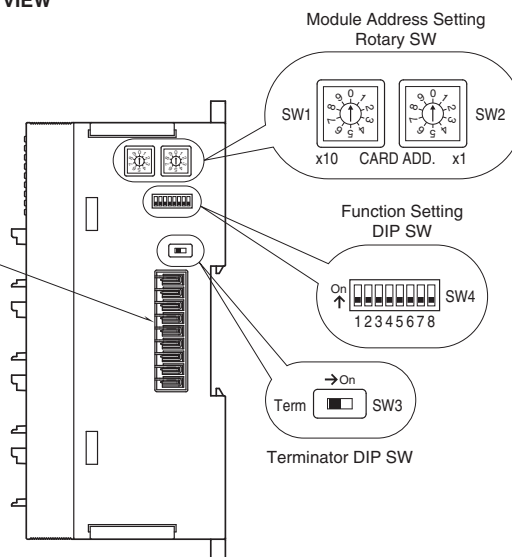

OPERATING MODE SETTING

(*) Factory setting

Caution ! - SW4-4 through 4-7 are unused. Be sure to turn off unused ones.

■ Module Address

The left switch determines the tenth place digit, while the right one does the ones place digit of the module address. Address is selected between 0 to 30.

(Factory setting: 0)

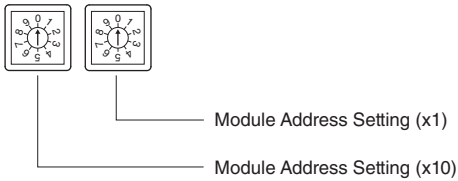

■ Clamp-on Current Sensor

Same range for all channels. Use PC Configurator to set independent ranges per channel.

CLAMP-ON CURRENT SENSOR	SW4		
	1	2	3
CLSE-R5: 0 – 5A AC (*)	OFF	OFF	OFF
CLSE-05: 0 – 50A AC	ON	OFF	OFF
CLSE-10: 0 – 100A AC	OFF	ON	OFF
CLSE-20: 0 – 200A AC	ON	ON	OFF
CLSE-40: 0 – 400A AC	OFF	OFF	ON
CLSE-60: 0 – 600A AC	ON	OFF	ON

■ Configuration Mode

CONFIGURATION MODE	SW4
	8
DIP switch setting (*)	OFF
PC Configurator and communication	ON

■ Terminator DIP SW

TERMINATOR SW	SW3
Without (*)	OFF
With	ON

EXTERNAL DIMENSIONS unit: mm [inch]

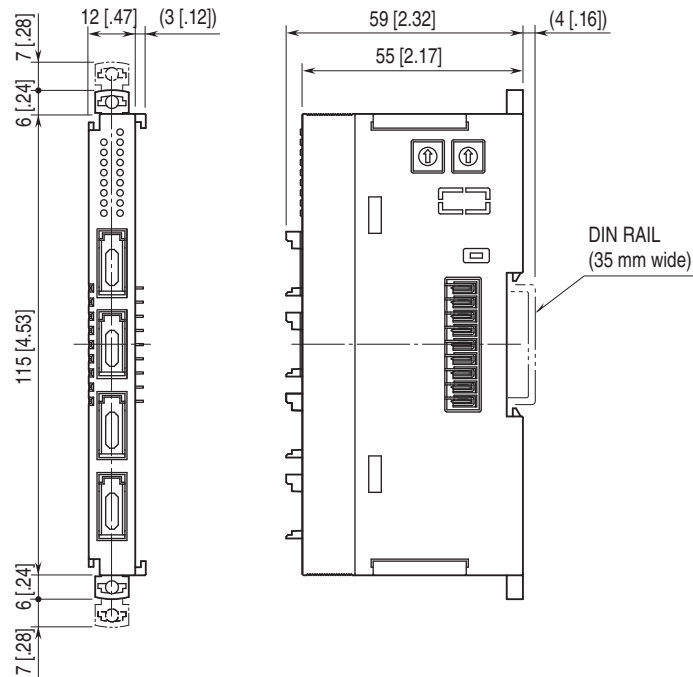

SCHEMATIC CIRCUITRY & CONNECTION DIAGRAM

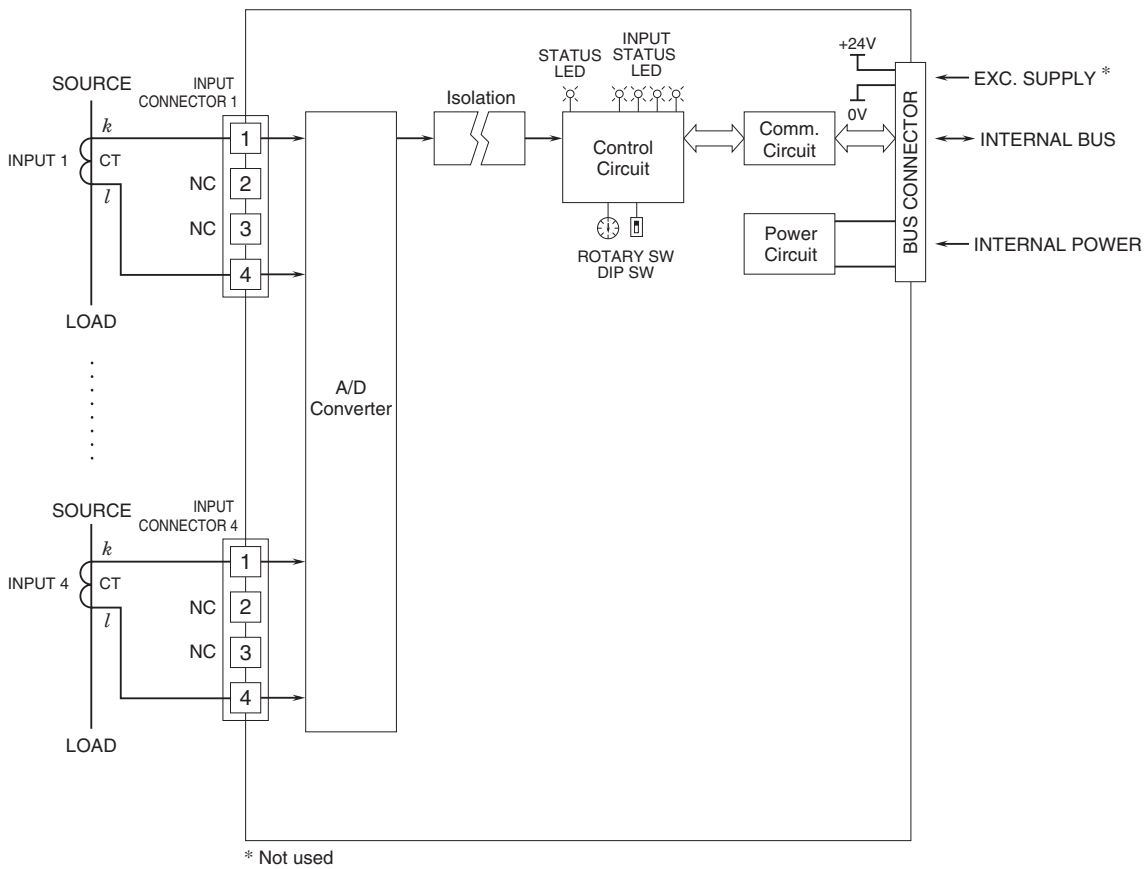



Specifications are subject to change without notice.