

DC VOLTAGE OUTPUT MODULE
(4 points, non-isolated)

MODEL **R8-YVT4N**

BEFORE USE

Thank you for choosing M-System. Before use, please check contents of the package you received as outlined below. If you have any problems or questions with the product, please contact M-System's Sales Office or representatives.

■ PACKAGE INCLUDES:

DC voltage output module.....(1)

■ MODEL NO.

Confirm Model No. marking on the product to be exactly what you ordered.

■ INSTRUCTION MANUAL

This manual describes necessary points of caution when you use this product, including installation, connection and basic maintenance procedures.

POINTS OF CAUTION

■ CONFORMITY WITH EU DIRECTIVES

- The equipment must be mounted inside a panel.
- The actual installation environments such as panel configurations, connected devices, connected wires, may affect the protection level of this unit when it is integrated in a panel system. The user may have to review the CE requirements in regard to the whole system and employ additional protective measures to ensure the CE conformity.

■ GENERAL PRECAUTIONS

- Before you remove or mount the unit, turn off the power supply and output signal for safety.
- Switches on the side of the module can be set for maintenance only while the power supply is off. Do not access them while the power is supplied.

■ ENVIRONMENT

- Indoor use.
- When heavy dust or metal particles are present in the air, install the unit inside proper housing with sufficient ventilation.
- Do not install the unit where it is subjected to continuous vibration. Do not subject the unit to physical impact.
- Environmental temperature must be within -10 to +55°C (14 to 131°F) with relative humidity within 30 to 90% RH in order to ensure adequate life span and operation.

■ WIRING

- Do not install cables close to noise sources (relay drive cable, high frequency line, etc.).
- Do not bind these cables together with those in which noises are present. Do not install them in the same duct.

■ AND

- The unit is designed to function as soon as power is supplied, however, a warm up for 10 minutes is required for satisfying complete performance described in the data sheet.

INSTALLATION

■ HOW TO MOUNT THE MODULE ON DIN RAIL

• I/O Module

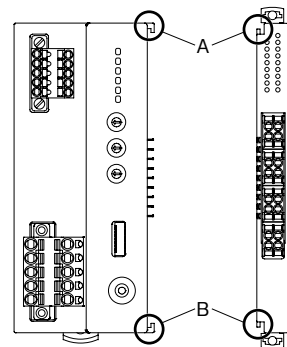

Confirm that the locking clamps of the I/O module are set. Insert the module in parallel to the next one while aligning the grooves of both modules (A & B in the above figure). Maintain it perpendicularly to the rail.

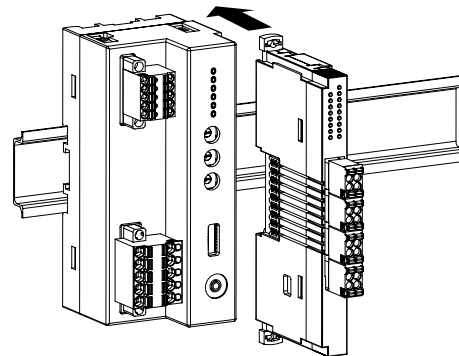

More I/O modules can be added in the same manner.

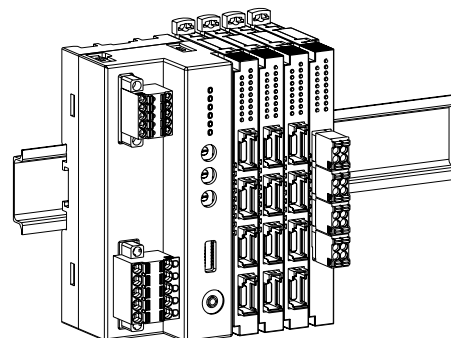

• Protective Cover

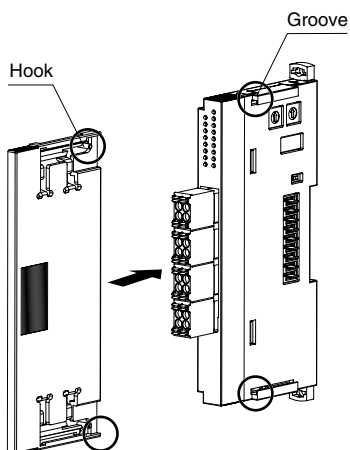

The protective cover is to be attached over the connected I/O module at the right end.

Align the hooks on the cover with the grooves of the module and slide it straight until the hooks are latched.

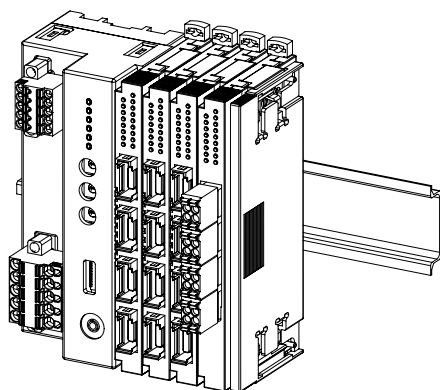

When removing the cover, pull it out while squeezing the hooks inward.

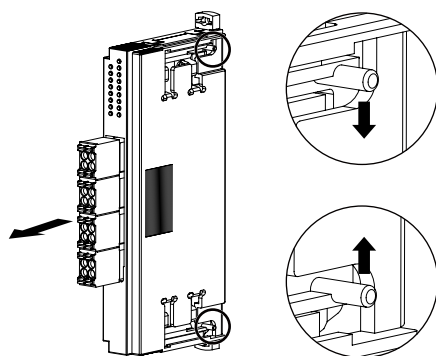

■ HOW TO UNMOUNT THE MODULE ON DIN RAIL

Release the locking clamps and pull out straight the module.

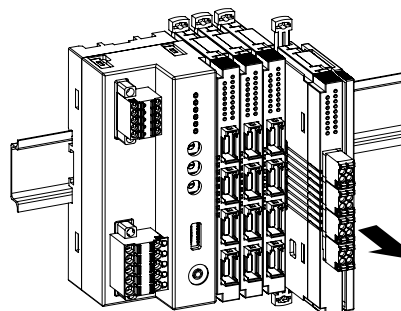
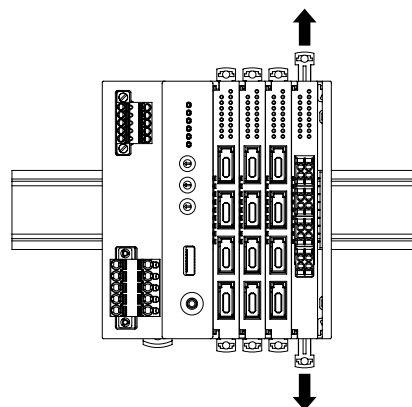

• Removing an intermediate module

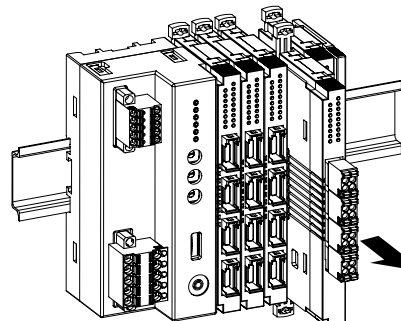
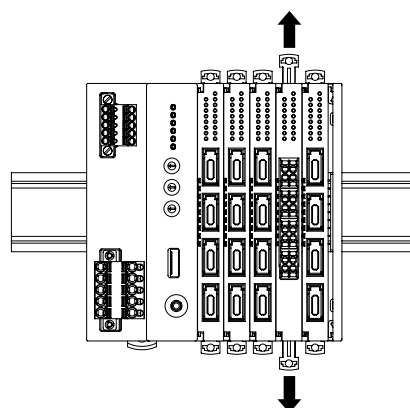

Caution !

- 1) Be careful not to hurt your hand by pointed edges of the internal bus connector.
- 2) I/O modules cannot hold tightly on the DIN rail by themselves without power/network module.

Secure them to the position if necessary by using DIN rail end plates.

COMPONENT IDENTIFICATION

■ FRONT VIEW

■ RIGHT VIEW

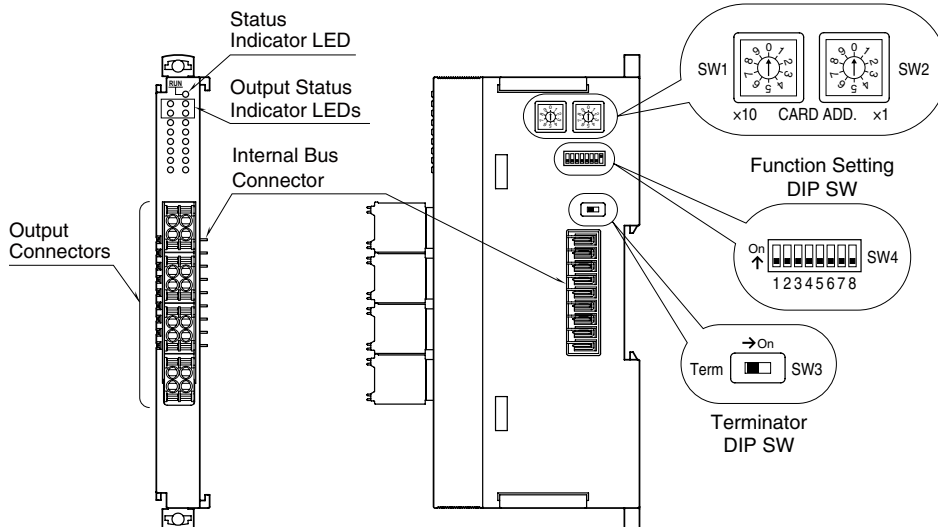

■ INDICATOR LED

ID	OPERATION	FUNCTION
Status	OFF	Stopping
	Green ON	Valid host communication
	Green Blinking	Reading/writing configuration
	Red ON	Setting error
Output Status	Red Blinking	Parameter error
	OFF	Output data in the range
	Red Blinking	Output data out of range

■ OUTPUT CONNECTOR ASSIGNMENT

PIN NO.	ID	FUNCTION
1	Ao 1	Output 1 (+)
2	AG	Output 1 (-)
3	NC	Unused
4	NC	Unused
5	Ao 2	Output 2 (+)
6	AG	Output 2 (-)
7	NC	Unused
8	NC	Unused
9	Ao 3	Output 3 (+)
10	AG	Output 3 (-)
11	NC	Unused
12	NC	Unused
13	Ao 4	Output 4 (+)
14	AG	Output 4 (-)
15	NC	Unused
16	NC	Unused

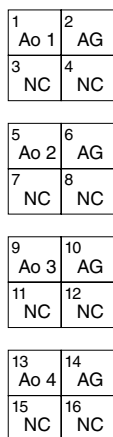

■ MODULE ADDRESS: SW1, 2

The left switch determines the tenth place digit, while the right one does the ones place digit of the module address. Address is selected between 0 to 30. (Factory setting: 0)

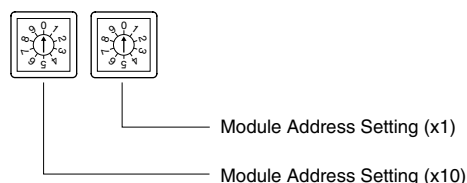

■ OPERATING MODE

(*) Factory setting

• Range: SW4-1, 4-2

Same setting for all channels. Use PC Configurator to set independent ranges per channel.

OUTPUT RANGE	SW4-1	SW4-2
-10 – +10V DC (*)	OFF	OFF
0 – 10V DC	ON	OFF
0 – 5V DC	OFF	ON
1 – 5V DC	ON	ON

• Output at the Loss of Communication: SW4-7

Same output for all channels.

OUTPUT AT THE LOSS OF COMMUNICATION	SW4-7
Output Hold (*)	OFF
(last data correctly received is hold)	
Stop output	ON

Note 1: For Stop output, output fixed at -5% when configuration mode is DIP switch setting. Output fixed at scaling value at the loss of communication when configuration mode is PC.

• **Configuration Mode: SW4-8**

CONFIGURATION MODE	SW4-8
DIP switch setting (*)	OFF
PC Configurator and communication	ON

Note 2: Be sure to set unused SW4-3 through 4-6 to OFF.

■ **TERMINATOR DIP SW: SW3**

TERMINATOR SW	SW3
Without (*)	OFF
With	ON

PC CONFIGURATOR

The following parameter items can be configured with PC Configurator Software (model: R8CFG). Refer to the users manual of the software for detailed operations.

■ **CHANNEL INDIVIDUAL SETTING**

PARAMETER	SETTING RAGNE	DEFAULT SETTING
Output range	-10 - 10 V DC	-10 - +10 V DC
Lower range value	-10.00 - +10 00 (V)	-10.00 (V)
Upper range value	-10.00 - +10 00 (V)	10.00 (V)
Fine zero adjustment	-320.00 - +320.00 (%)	0.00 (%)
Fine gain adjustment	-3.2000 - +3.2000	1.0000
Scaled range Zero	-32000 - +32000	0
Scaled range Span	-32000 - +32000	10000
Initial output at the startup (scaled range)	-32000 - +32000	0
Fixed output at the loss of communication (scaled range)	-32000 - +32000	-500

■ **CHANNEL BATCH SETTING**

PARAMETER	SETTING RAGNE	DEFAULT SETTING
Loss of internal bus communication detection time	0.0 – 99.9 (sec.)	1.0 (sec.)
Output function at the loss of communication	Hold the last normally received data Fixed output as specified	Hold the last normally received data
Configuration mode	DIP SW (OFF) PC (ON)	DIP SW (OFF)

Note. Be sure to set SW4-8 to ON to configure output range and output at the loss of communication by the PC configurator. Settings are programmed by the PC Configurator via the Power/Network Module.

TERMINAL CONNECTIONS

Connect the unit as in the diagram below.

EXTERNAL DIMENSIONS unit: mm [inch]

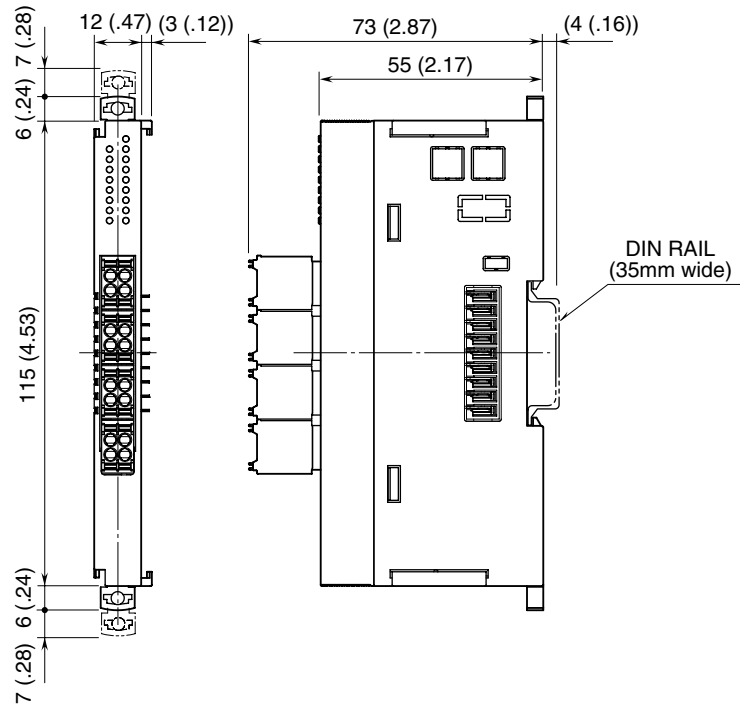

CONNECTION DIAGRAM

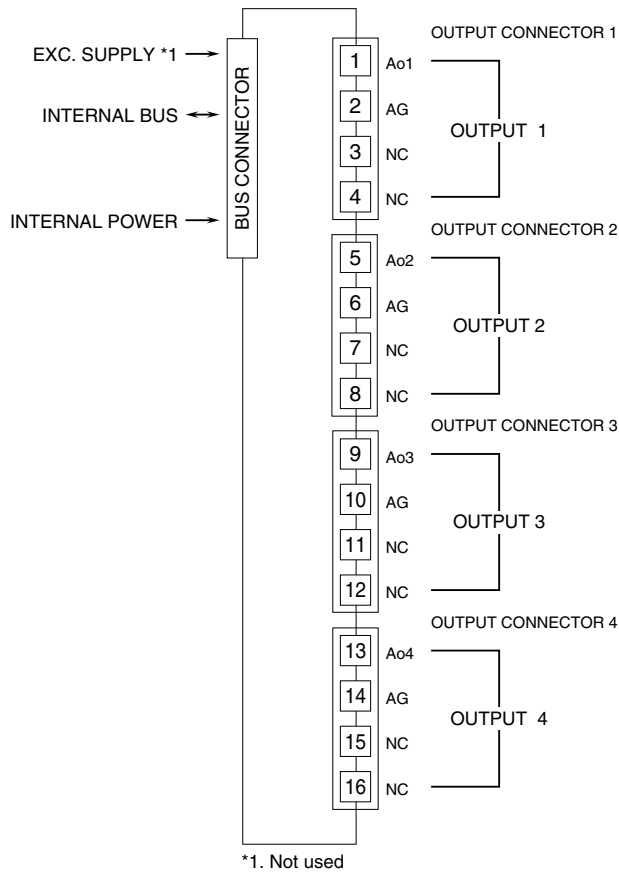

WIRING INSTRUCTIONS

■ TENSION CLAMP

Unit side connector: M-System's product

Cable side connector: DFMC1,5/2-ST-3,5 (Phoenix Contact)
(included in the package)

Applicable wire size: 0.2 - 1.5 mm²

Stripped length: 10 mm

Recommended solderless terminal

- AI0,25-10YE 0.25 mm² (Phoenix Contact)
- AI0,34-10TQ 0.34 mm² (Phoenix Contact)
- AI0,5-10WH 0.5 mm² (Phoenix Contact)
- AI0,75-10GY 0.75 mm² (Phoenix Contact)
- A1-10 1.0 mm² (Phoenix Contact)
- A1,5-10 1.5 mm² (Phoenix Contact)