

NPN TRANSISTOR INPUT MODULE
(NPN transistor, 16 points)

MODEL R8-DAM16A

BEFORE USE

Thank you for choosing M-System. Before use, check the contents of the package you received as below.

If you have any problems or questions with the product, please contact M-System's Sales Office or representatives.

PACKAGE INCLUDES:

Discrete input module..... (1)

MODEL NO.

Confirm that the model number described on the product is exactly what you ordered.

INSTRUCTION MANUAL

This manual describes necessary points of caution when you use this product, including installation, connection and basic maintenance procedures.

POINTS OF CAUTION

CONFORMITY WITH EU DIRECTIVES

- The equipment must be mounted inside a panel.
- The actual installation environments such as panel configurations, connected devices and connected wires may affect the protection level of this unit when it is integrated in a panel system. The user may have to review the CE requirements in regard to the whole system and employ additional protective measures to ensure CE conformity.

GENERAL PRECAUTIONS

- Before you remove or mount the unit, turn off the power supply and input signal for safety.
- Switches on the side of the module can be set for maintenance only while the power supply is off. Do not access them while the power is supplied.

ENVIRONMENT

- Indoor use
- When heavy dust or metal particles are present in the air, install the unit inside proper housing with sufficient ventilation.
- Do not install the unit where it is subjected to continuous vibration. Do not apply physical impact to the unit.
- Environmental temperature must be within -10 to +55°C (14 to 131°F) with relative humidity within 30 to 90% RH in order to ensure adequate life span and operation.

WIRING

- Do not install cables close to noise sources (relay drive cable, high frequency line, etc.).
- Do not bind these cables together with those in which noises are present. Do not install them in the same duct.

EXCITATION SUPPLY

- Input terminal: Rated current 3 A DC (rated current 3 A for internal fuse (slow blow fuse i^2t (A²sec) max. 5.04)

AND

- The unit is designed to function as soon as power is supplied, however, a warm up for 10 minutes is required for satisfying complete performance described in the data sheet.

INSTALLATION

HOW TO MOUNT THE MODULE ON DIN RAIL

I/O Module

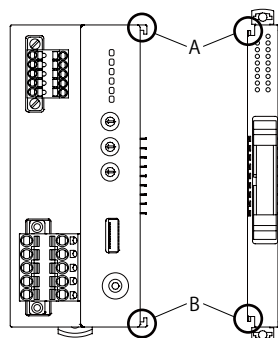

Confirm that the locking clamps of the I/O module are set. Insert the module in parallel to the next one while aligning the grooves of both modules (A & B in the above figure). Maintain it perpendicularly to the rail.

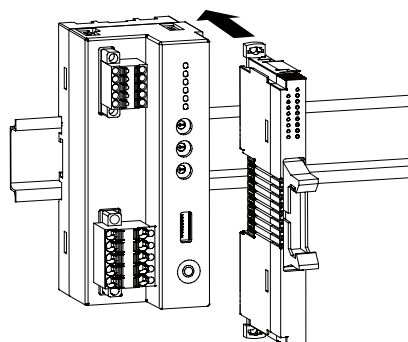

More I/O modules can be added in the same manner.

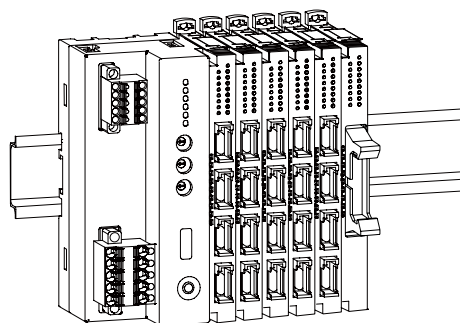

• Protective Cover

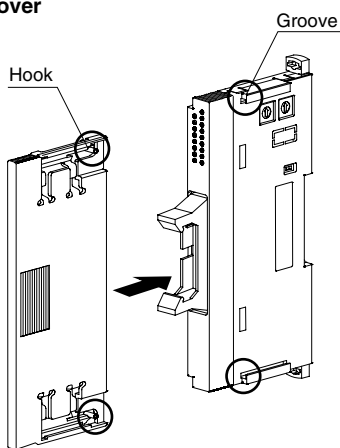

The protective cover is to be attached over the connected I/O module at the right end.
Align the hooks on the cover with the grooves of the module and slide it straight until the hooks are latched.

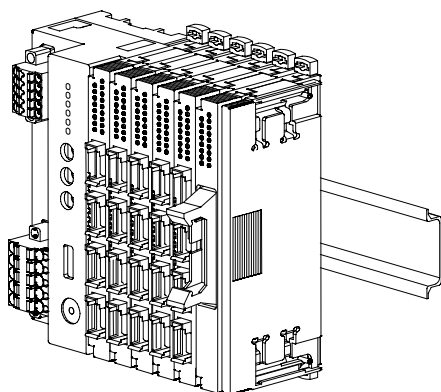

When removing the cover, pull it out while squeezing the hooks inward.

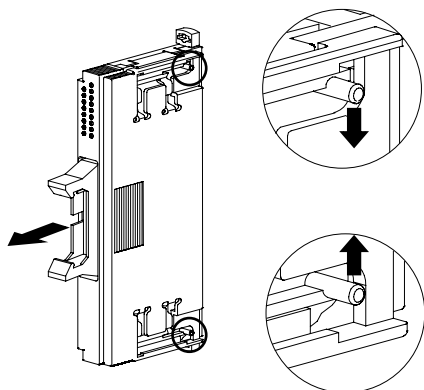

■ HOW TO UNMOUNT THE MODULE FROM DIN RAIL

Release the locking clamps and pull out straight the module.

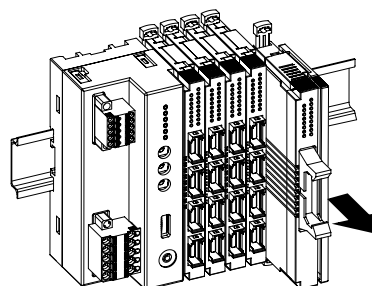
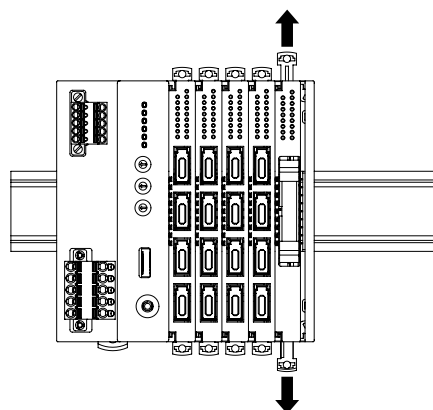

• Removing an intermediate module

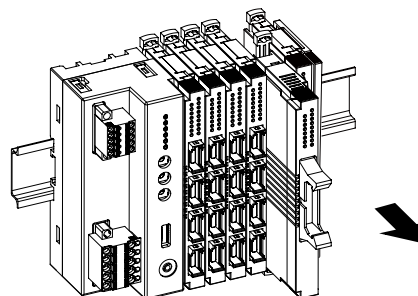
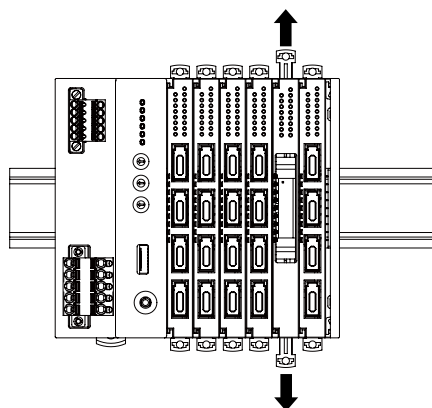

Caution !

- 1) Be careful not to hurt your hand by pointed edges of the internal communication bus connector.
- 2) I/O modules cannot hold tightly on the DIN rail by themselves without power/network module.
Secure them to the position if necessary by using DIN rail end plates.

COMPONENT IDENTIFICATION

FRONT VIEW

SIDE VIEW

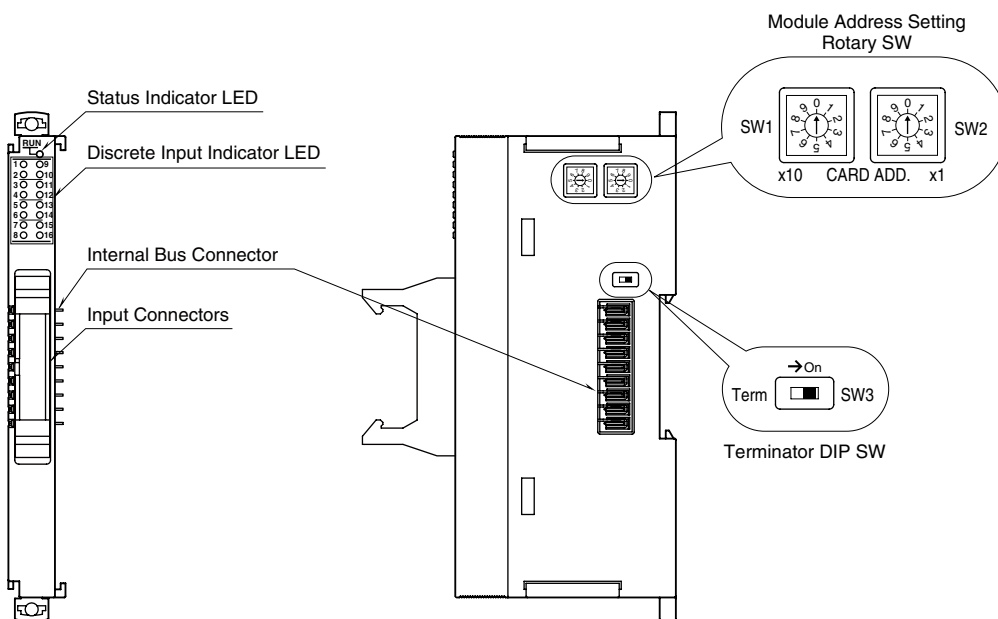

INDICATOR LED

LED	OPERATION	FUNCTION
Status	OFF	Stopping
	Green ON	Valid host communication
	Green Blinking	Reading/writing configuration
	Red ON	Setting error
Input Status	OFF	OFF
	Green ON	ON

INPUT CONNECTOR ASSIGNMENT

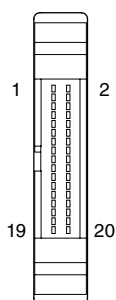

PIN No.	ID	FUNCTION
1	Di1	Input 1
2	Di2	Input 2
3	Di3	Input 3
4	Di4	Input 4
5	Di5	Input 5
6	Di6	Input 6
7	Di7	Input 7
8	Di8	Input 8
9	Di9	Input 9
10	Di10	Input 10
11	Di11	Input 11
12	Di12	Input 12
13	Di13	Input 13
14	Di14	Input 14
15	Di15	Input 15
16	Di16	Input 16
17, 18	0V	Excitation supply 0V
19, 20	24V	Excitation supply 24V

MODULE ADDRESS

The left switch determines the tenth place digit, while the right switch does the ones place digit of the address. Address is selected between 0 to 31. (Factory setting: 0)

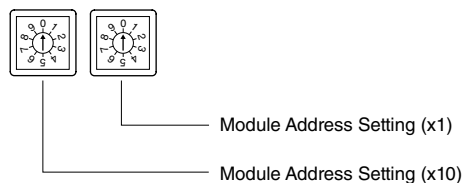

TERMINATOR DIP SW

TERMINATOR SW	SW3
Without (*)	OFF
With	ON

*Factory setting

PC CONFIGURATOR

The following parameters can be set with using PC Configurator Software (model: R8CFG):

- Loss of internal bus communication detection time
- Sampling cycle

Settings are programmed by the PC Configurator via the Power/Network Module. Refer to the users manual for the R8CFG for detailed operation of the software program.

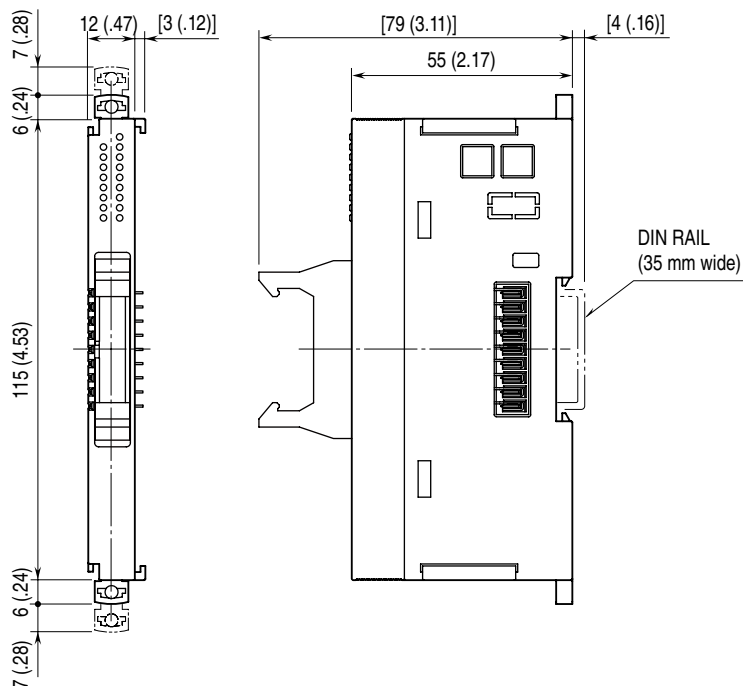
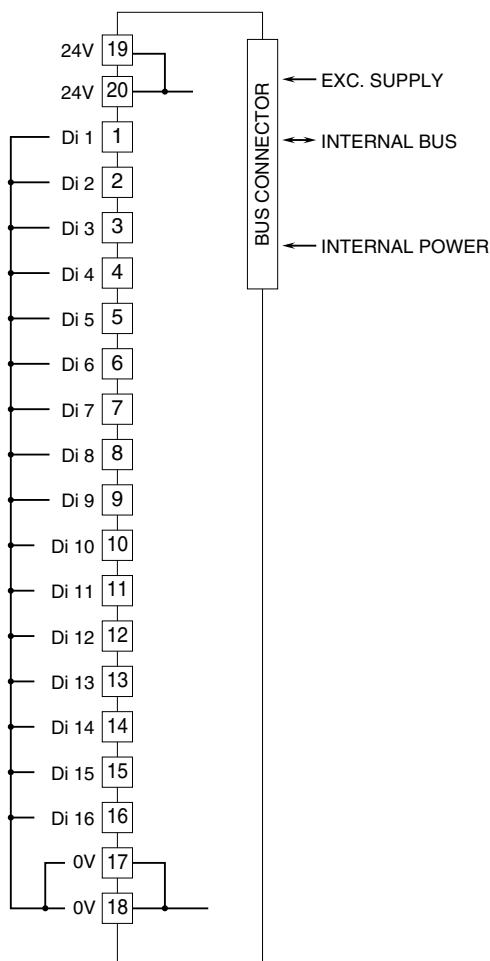
EXTERNAL DIMENSIONS unit: mm (inch)**CONNECTION DIAGRAM****WIRING INSTRUCTIONS**

■ MIL connector

PWB connector: M-System

Recommended socket XG5N-201 (Omron)*1

Recommended contact XG5W-0231 (Omron)*1

Applicable wire size: AWG22, 17 strands, (0.16 dia)

*1. Not included in the package. Refer to the specifications of the product.