

| | |
|--|--|
| <h2 style="margin: 0;">AC CURRENT INPUT MODULE</h2> <p style="margin: 0;">(4 points, RMS sensing, clamp-on current sensor, non-isolated)</p> | <p style="margin: 0;">MODEL R8-CT4E</p> |
|--|--|

BEFORE USE

Thank you for choosing M-System. Before use, please check contents of the package you received as outlined below. If you have any problems or questions with the product, please contact M-System's Sales Office or representatives.

■ PACKAGE INCLUDES:

AC current input module (1)

■ MODEL NO.

Confirm Model No. marking on the product to be exactly what you ordered.

■ INSTRUCTION MANUAL

This manual describes necessary points of caution when you use this product, including installation, connection and basic maintenance procedures.

POINTS OF CAUTION

■ CONFORMITY WITH EU DIRECTIVES

- The equipment must be mounted inside a panel.
- The actual installation environments such as panel configurations, connected devices, connected wires, may affect the protection level of this unit when it is integrated in a panel system. The user may have to review the CE requirements in regard to the whole system and employ additional protective measures to ensure the CE conformity.

■ GENERAL PRECAUTIONS

- Before you remove or mount the unit, turn off the power supply and input signal for safety.
- Switches on the side of the module can be set for maintenance only while the power supply is off. Do not access them while the power is supplied.

■ ENVIRONMENT

- Indoor use.
- When heavy dust or metal particles are present in the air, install the unit inside proper housing with sufficient ventilation.
- Do not install the unit where it is subjected to continuous vibration. Do not subject the unit to physical impact.
- Environmental temperature must be within -10 to +55°C (14 to 131°F) with relative humidity within 30 to 90% RH in order to ensure adequate life span and operation.

■ WIRING

- Do not install cables close to noise sources (relay drive cable, high frequency line, etc.).
- Do not bind these cables together with those in which noises are present. Do not install them in the same duct.

■ AND

- The unit is designed to function as soon as power is supplied, however, a warm up for 10 minutes is required for satisfying complete performance described in the data sheet.

INSTALLATION

■ HOW TO MOUNT THE MODULE ON DIN RAIL

• I/O Module

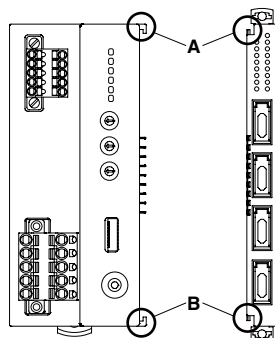

Confirm that the locking clamps of the I/O module are set. Insert the module in parallel to the next one while aligning the grooves of both modules (A & B in the above figure). Maintain it perpendicularly to the rail.

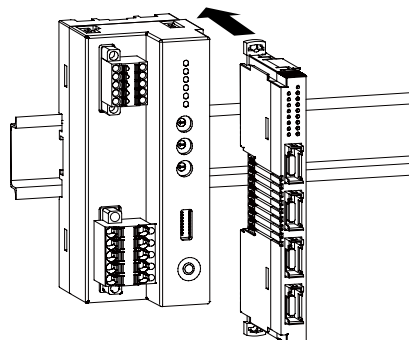

More I/O modules can be added in the same manner.

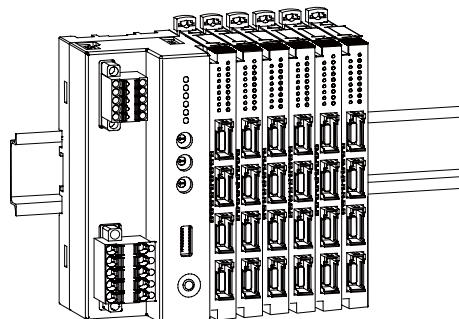

• Protective Cover

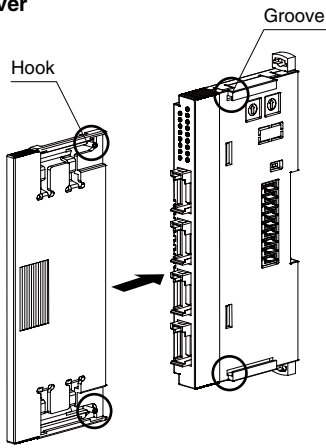

The protective power is to be attached over the connected I/O module at the right end.
Align the hooks on the cover with the grooves of the module and slide it straight until the hooks are latched.

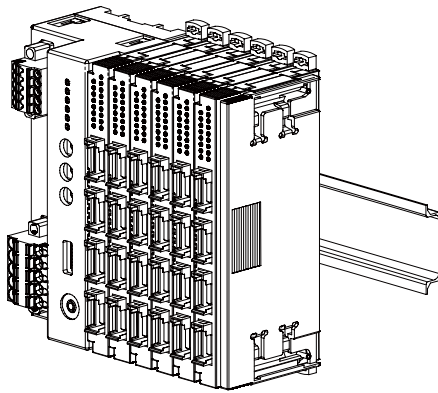

When removing the cover, pull it out while squeezing the hooks inward.

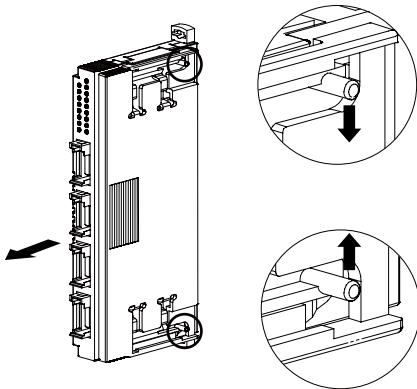

■ HOW TO UNMOUNT THE MODULE ON DIN RAIL

Release the locking clamps and pull out straight the module.

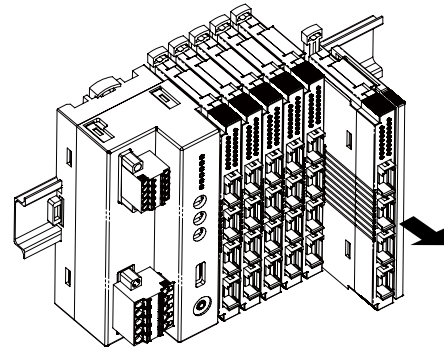
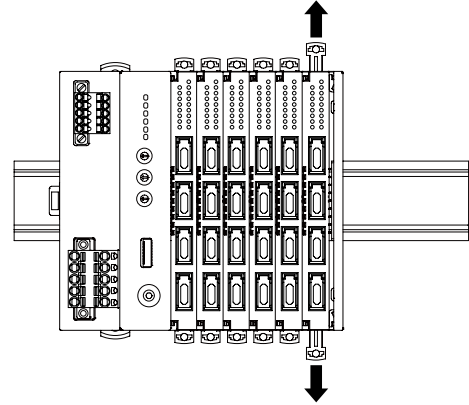

• Removing an intermediate module

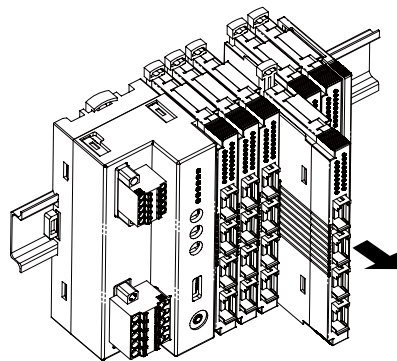
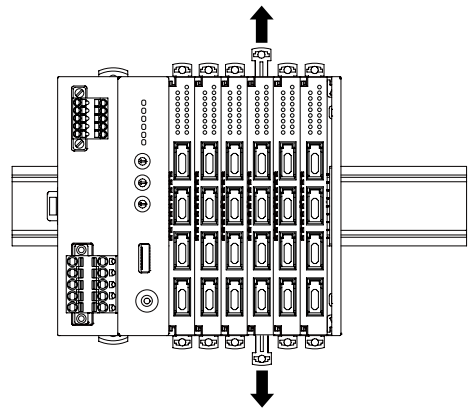

Caution !

- 1) Be careful not to hurt your hand by pointed edges of the internal bus connector.
- 2) I/O modules cannot hold tightly on the DIN rail by themselves without power/network module.
Secure them to the position if necessary by using DIN rail end plates.

COMPONENT IDENTIFICATION

FRONT VIEW

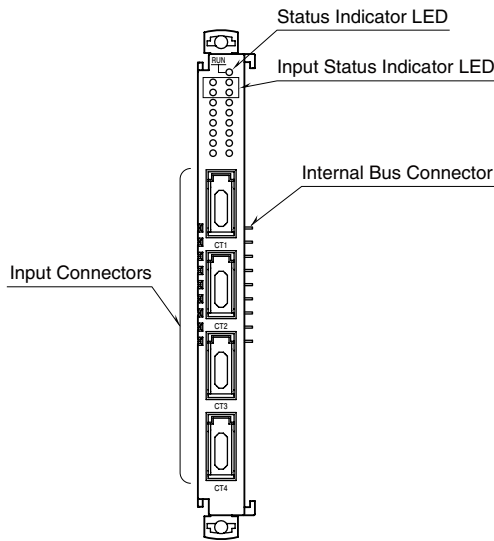

SIDE VIEW

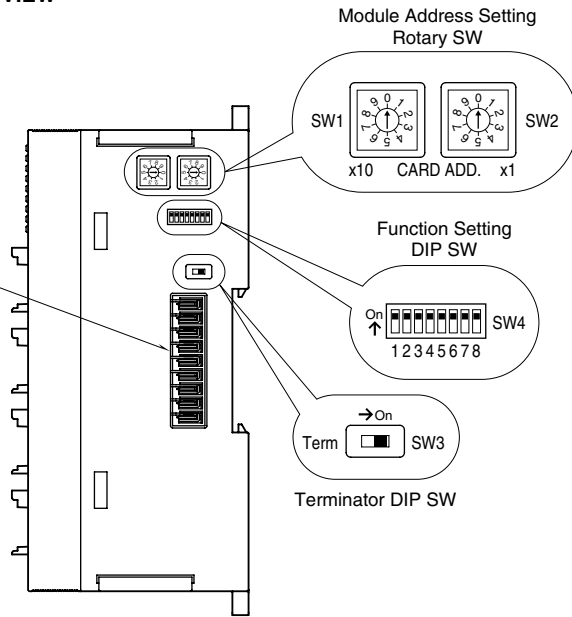

INDICATOR LED

| LED | OPERATION | FUNCTION |
|--------------|----------------|-------------------------------|
| Status | OFF | Stopping |
| | Green ON | Valid host communication |
| | Green Blinking | Reading/writing configuration |
| | Red ON | Setting error |
| | Red Blinking | Parameter error |
| Input Status | OFF | Input data in the range |
| | Red Blinking | Input data out of range |

INPUT CONNECTOR ASSIGNMENT

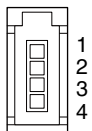

| PIN No. | ID | FUNCTION |
|---------|----------|---------------|
| 1 | <i>k</i> | Input |
| 2 | NC | No connection |
| 3 | NC | No connection |
| 4 | <i>l</i> | Input |

MODULE ADDRESS

The left switch determines the tenth place digit, while the right switch does the ones place digit of the address. Address is selected between 0 to 30. (Factory setting: 0)

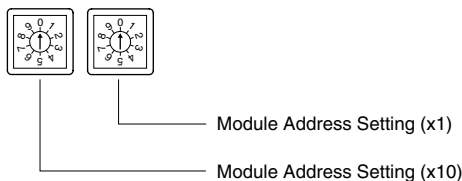

OPERATING MODE

(*) Factory setting

Clamp-on Current Sensor Setting

Same range for all channels. Use PC Configurator to set independent ranges per channel.

| CLUMP-ON CURRENT SENSOR | SW4 | | |
|-------------------------|-----|-----|-----|
| | 1 | 2 | 3 |
| CLSE-R5 : 0 – 5A AC (*) | OFF | OFF | OFF |
| CLSE-05 : 0 – 50A AC | ON | OFF | OFF |
| CLSE-10 : 0 – 100A AC | OFF | ON | OFF |
| CLSE-20 : 0 – 200A AC | ON | ON | OFF |
| CLSE-40 : 0 – 400A AC | OFF | OFF | ON |
| CLSE-60 : 0 – 600A AC | ON | OFF | ON |

Configuration Mode

| | |
|-----------------------------------|-------|
| CONFIGURATION MODE | SW4-8 |
| DIP switch setting (*) | OFF |
| PC Configurator and communication | ON |

Note: Be sure to set unused SW4-4 through 4-7 to OFF.

TERMINATOR DIP SW

| | |
|---------------|-----|
| TERMINATOR SW | SW3 |
| Without (*) | OFF |
| With | ON |

PC CONFIGURATOR

With configurator software, settings shown below are available.
Refer to the software manual of R8CFG for detailed operation.

■ CHANNEL INDIVIDUAL SETTING

| PARAMETER | AVAILABLE RANGE | DEFAULT SETTING |
|----------------------|--|-----------------|
| Sensor type | CLSE-R5 CLSE-05 CLSE-10 CLSE-20 CLSE-40 CLSE-60 | CLSE-R5 |
| Lower range value | Depends on sensor type | 0.000 |
| Upper range value | Depends on sensor type | 0.000 |
| Fine zero adjustment | -320.00 to +320.00 (%) | 0.00 (%) |
| Fine gain adjustment | -3.2000 to +3.2000 | 1.0000 |
| Scaled range Zero | -32000 to +32000 | 0 |
| Scaled range Span | -32000 to +32000 | 10000 |
| Low-end cutout | 0.0 to 5.0 (%) | 1.0 (%) |

■ CHANNEL BATCH SETTING

| PARAMETER | AVAILABLE RANGE | DEFAULT SETTING |
|---|-----------------------------|------------------|
| Loss of internal bus communication detection time | 0.0 to 99.9 (sec.) | 1.0 (sec.) |
| Configuration mode | DIP switch (OFF) PC (ON) | DIP switch (OFF) |

Note: Turn SW4-8 ON to allow programming by the PC Configurator via the Power/Network Module.

TERMINAL CONNECTIONS

Connect the unit as in the diagram below.

■ EXTERNAL DIMENSIONS unit: mm (inch)

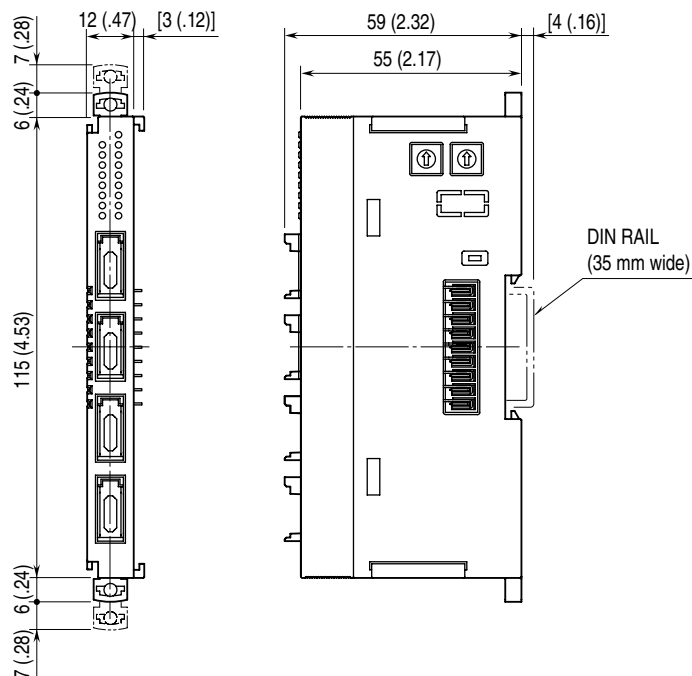

CONNECTION DIAGRAM

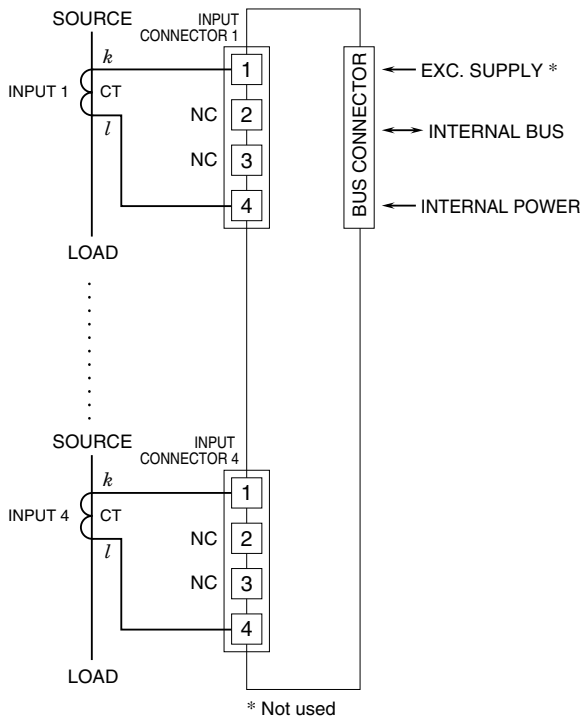

WIRING INSTRUCTIONS

e-CON connector

Unit side connector: XN2D-1474-S002 (Omron)

Recommended cable side connector: XN2A-1470 (Omron)*1

Applicable wire size: 0.08 to 0.5 mm² (AWG28 to 20)

Outer sheath diameter: max. 1.5 dia

*1. The cable side connector is not included in the package.

Refer to the specifications of the product.