

BEFORE USE

Thank you for choosing M-System. Before use, check the contents of the package you received as outlined below.

If you have any problems or questions with the product, please contact M-System's Sales Office or representatives.

■ PACKAGE INCLUDES:

- Discrete I/O module..... (1)
- Surface mounter slider..... (2)

■ MODEL NO.

Confirm that the model number described on the product is exactly what you ordered.

■ INSTRUCTION MANUAL

This manual describes necessary points of caution when you use this product, including installation, connection and basic maintenance procedures.

POINTS OF CAUTION**■ CONFORMITY WITH EC DIRECTIVE**

- The actual installation environments such as panel configurations, connected devices and connected wires may affect the protection level of this unit when it is integrated in a panel system. The user may have to review the CE requirements in regard to the whole system and employ additional protective measures to ensure CE conformity.

■ POWER INPUT RATING & OPERATIONAL RANGE

- Locate the power input rating marked on the product and confirm its operational range as indicated below:
24V DC rating: 24V \pm 10%, approx. 75mA

■ REMOVING THE UNIT

Before you remove the unit or mount it, turn off the power supply, input signal and output signal for safety.

■ ENVIRONMENT

- Indoor use
- When heavy dust or metal particles are present in the air, install the unit inside proper housing with sufficient ventilation.
- Do not install the unit where it is subjected to continuous vibration. Do not apply physical impact to the unit.
- Environmental temperature must be within 0 to +55°C (32 to 131°F) with relative humidity within 30 to 90% RH in order to ensure adequate life span and operation.

■ WIRING

- Do not install cables close to noise sources (relay drive cable, high frequency line, etc.).
- Do not bind these cables together with those in which noises are present. Do not install them in the same duct.

■ AND

The unit is designed to function as soon as power is supplied, however, a warm up for 10 minutes is required for satisfying complete performance described in the data sheet.

COMPONENT IDENTIFICATION

FRONT VIEW

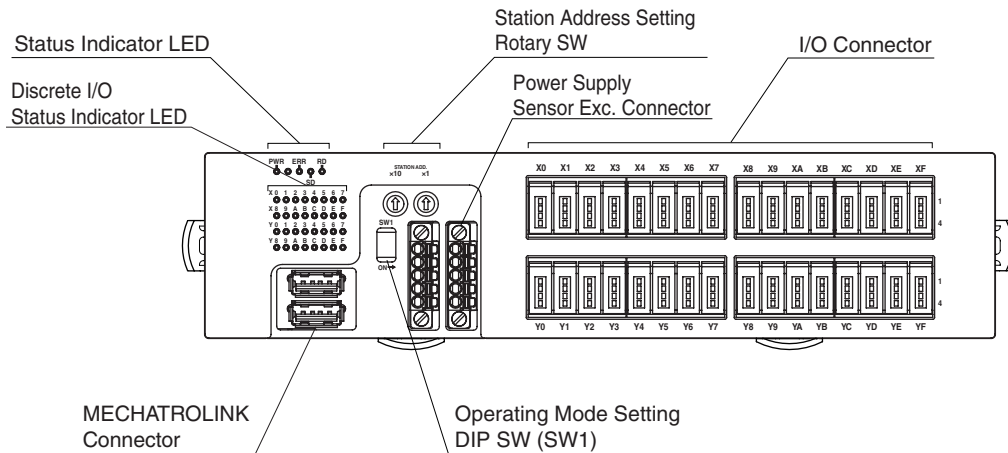

STATUS INDICATOR LED

ID	COLOR	FUNCTION
PWR	Green	Turns on when internal power is supplied normally, and off with internal power failure.
ERR	Red	Turns on with station address setting error, and off with normal station address setting.
SD	Green	Turns on when transmitting data, and off when not transmitting data.
RD	Green	Turns on when receiving data, and off when not receiving data.

DISCRETE I/O STATUS INDICATOR LED

LED green indicators show each I/O signal status.

- ON : LED ON
- OFF : LED OFF

STATION ADDRESS

The left switch determines the upper digit, while the right switch does the lower digit of the station address (hexadecimal number).

(Range: 60H to 7FH)*

(Factory setting: 61H)

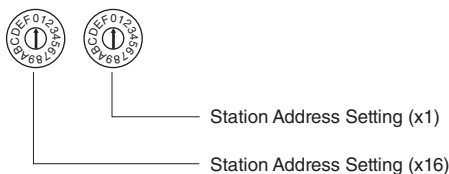

* As R7K4DML is simple I/O, set the station address within the range from 60H to 7FH.

Refer to the instruction manual of the master unit for unselectable addresses, which depending on master unit types.

MECHATROLINK MODE

Set either MECHATROLINK-I or -II, and the data size with SW1-1 and SW1-2.

SW1-1	SW1-2	MECHATROLINK
OFF	OFF	MECHATROLINK-II (32 byte mode) (*)
ON	OFF	MECHATROLINK-II (17 byte mode)
ON	ON	MECHATROLINK-I (17 byte mode)

(*) Factory setting

Caution ! - Since SW1-3 and SW1-4 are unused, be sure to turn them off.

POWER SUPPLY, SENSOR EXCITATION

Cable connector: FMC1,5 / 5-STF-3,5

(Phoenix Contact) (included in the package)

Applicable wire size: 0.2 – 1.5 mm²; stripped length 10 mm

Recommended solderless terminal

- A10,25-10YE 0.25 mm² (Phoenix Contact)
- A10,34-10TQ 0.34 mm² (Phoenix Contact)
- A10,5-10WH 0.5 mm² (Phoenix Contact)
- A10,75-10GY 0.75 mm² (Phoenix Contact)
- A1-10 1.0 mm² (Phoenix Contact)
- A1,5-10 1.5 mm² (Phoenix Contact)

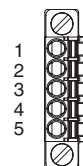

- 1. PWR+ Power Supply (24 V DC)
- 2. PWR- Power Supply (0 V)
- 3. FE Functional earth
- 4. SNSR.EXC+ Sensor excitation (24 V DC)
- 5. SNSR.EXC- Sensor excitation (0 V)

■ TERMINAL ASSIGNMENTS

• I/O Connection

Recommended cable connector: 37104-()-000FL (3M Company)

(The cable connector is not included in the package. Specify wire size instead of (); refer to the specifications of the product.)

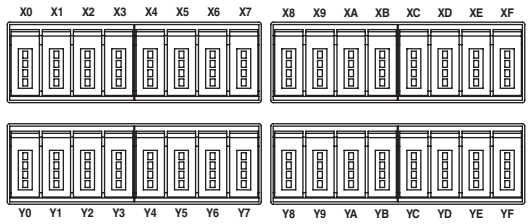

No.	ID	FUNCTION	No.	ID	FUNCTION
X0	1	+24V 24V DC	X8	1	+24V 24V DC
	2	NC Unused		2	NC Unused
	3	GND 0V		3	GND 0V
	4	X0 Input 0		4	X8 Input 8
X1	1	+24V 24V DC	X9	1	+24V 24V DC
	2	NC Unused		2	NC Unused
	3	GND 0V		3	GND 0V
	4	X1 Input 1		4	X9 Input 9
X2	1	+24V 24V DC	XA	1	+24V 24V DC
	2	NC Unused		2	NC Unused
	3	GND 0V		3	GND 0V
	4	X2 Input 2		4	XA Input 10
X3	1	+24V 24V DC	XB	1	+24V 24V DC
	2	NC Unused		2	NC Unused
	3	GND 0V		3	GND 0V
	4	X3 Input 3		4	XB Input 11
X4	1	+24V 24V DC	XC	1	+24V 24V DC
	2	NC Unused		2	NC Unused
	3	GND 0V		3	GND 0V
	4	X4 Input 4		4	XC Input 12
X5	1	+24V 24V DC	XD	1	+24V 24V DC
	2	NC Unused		2	NC Unused
	3	GND 0V		3	GND 0V
	4	X5 Input 5		4	XD Input 13
X6	1	+24V 24V DC	XE	1	+24V 24V DC
	2	NC Unused		2	NC Unused
	3	GND 0V		3	GND 0V
	4	X6 Input 6		4	XE Input 14
X7	1	+24V 24V DC	XF	1	+24V 24V DC
	2	NC Unused		2	NC Unused
	3	GND 0V		3	GND 0V
	4	X7 Input 7		4	XF Input 15

No.	ID	FUNCTION	No.	ID	FUNCTION
Y0	1	NC Unused	Y8	1	NC Unused
	2	NC Unused		2	NC Unused
	3	GND 0V		3	GND 0V
	4	Y0 Output 0		4	Y8 Output 8
Y1	1	NC Unused	Y9	1	NC Unused
	2	NC Unused		2	NC Unused
	3	GND 0V		3	GND 0V
	4	Y1 Output 1		4	Y9 Output 9
Y2	1	NC Unused	YA	1	NC Unused
	2	NC Unused		2	NC Unused
	3	GND 0V		3	GND 0V
	4	Y2 Output 2		4	YA Output 10
Y3	1	NC Unused	YB	1	NC Unused
	2	NC Unused		2	NC Unused
	3	GND 0V		3	GND 0V
	4	Y3 Output 3		4	YB Output 11
Y4	1	NC Unused	YC	1	NC Unused
	2	NC Unused		2	NC Unused
	3	GND 0V		3	GND 0V
	4	Y4 Output 4		4	YC Output 12
Y5	1	NC Unused	YD	1	NC Unused
	2	NC Unused		2	NC Unused
	3	GND 0V		3	GND 0V
	4	Y5 Output 5		4	YD Output 13
Y6	1	NC Unused	YE	1	NC Unused
	2	NC Unused		2	NC Unused
	3	GND 0V		3	GND 0V
	4	Y6 Output 6		4	YE Output 14
Y7	1	NC Unused	YF	1	NC Unused
	2	NC Unused		2	NC Unused
	3	GND 0V		3	GND 0V
	4	Y7 Output 7		4	YF Output 15

■ MECHATROLINK CONNECTION

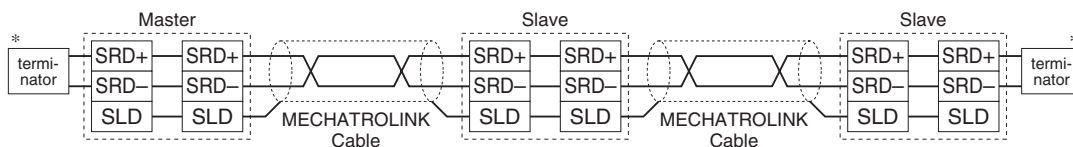

*Terminator

Be sure to connect the terminating resistors to the unit at both ends of transmission line.

Use the terminating resistor dedicated for MECHATROLINK: Model JEPMC-W6022, Yaskawa Controls Co., Ltd.

Certain types of Master units may have incorporated terminating resistors. Consult the instruction manual for the Master.

MOUNTING INSTRUCTIONS

■ DIN RAIL MOUNTING

• Mounting

- 1) Set the upper hook at the rear side of the unit on the DIN rail.
- 2) Push in the lower.

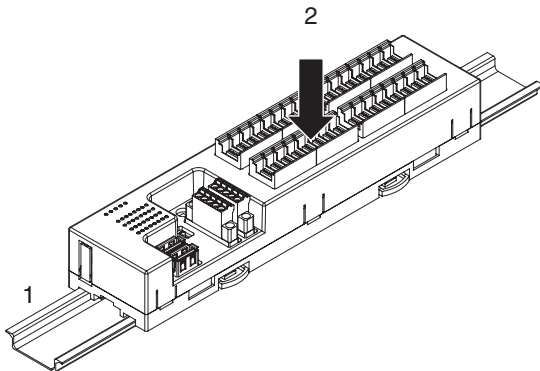

• Dismounting

- 1) Push down the DIN rail mounter slider with the tip of a minus screwdriver.
- 2) Pull the lower of the unit.
- 3) Remove the upper hook of the unit from the DIN rail.

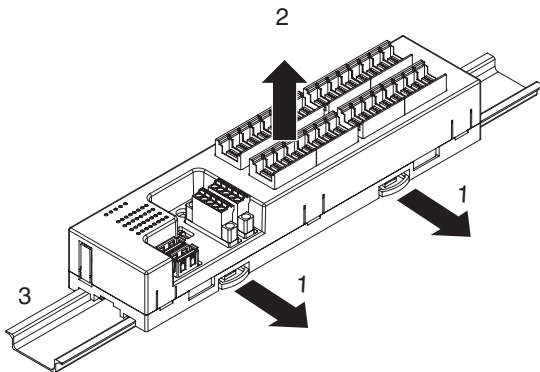

■ SURFACE MOUNTING

- 1) Insert the two DIN rail mounter sliders until it clicks once, as shown below.

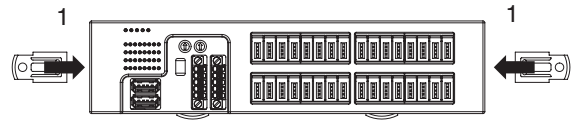

- 2) Mount the unit with M4 screws referring to the EXTERNAL DIMENSIONS. (Torque: 1.4 N-m)

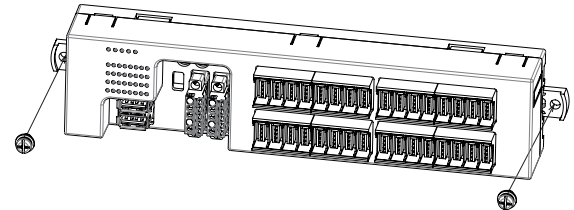

MOUNTING REQUIREMENTS unit: mm (inch)

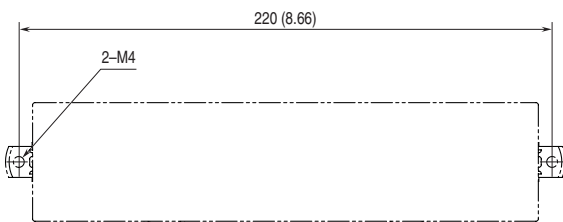

TERMINAL CONNECTIONS

Connect the unit as in the diagram below.

EXTERNAL DIMENSIONS mm (inch)

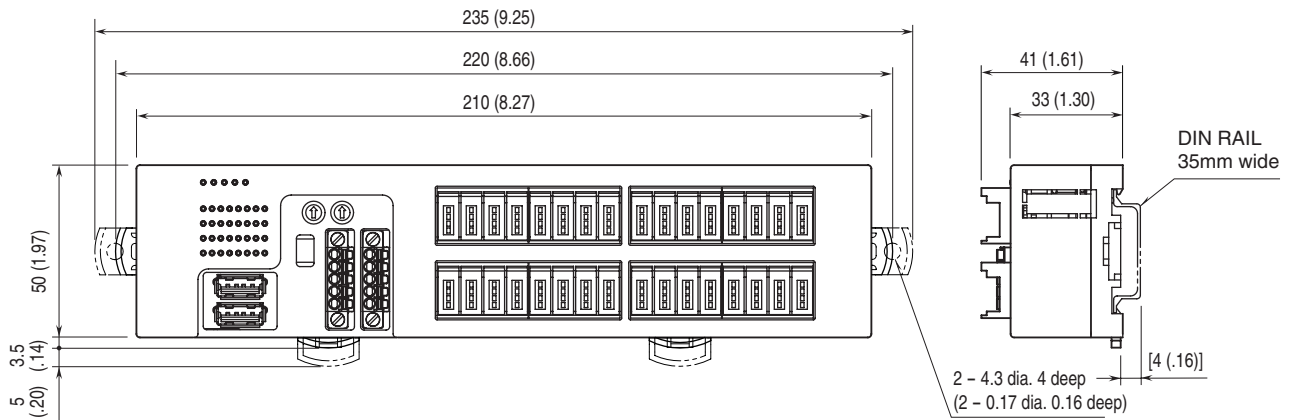

CONNECTION DIAGRAM

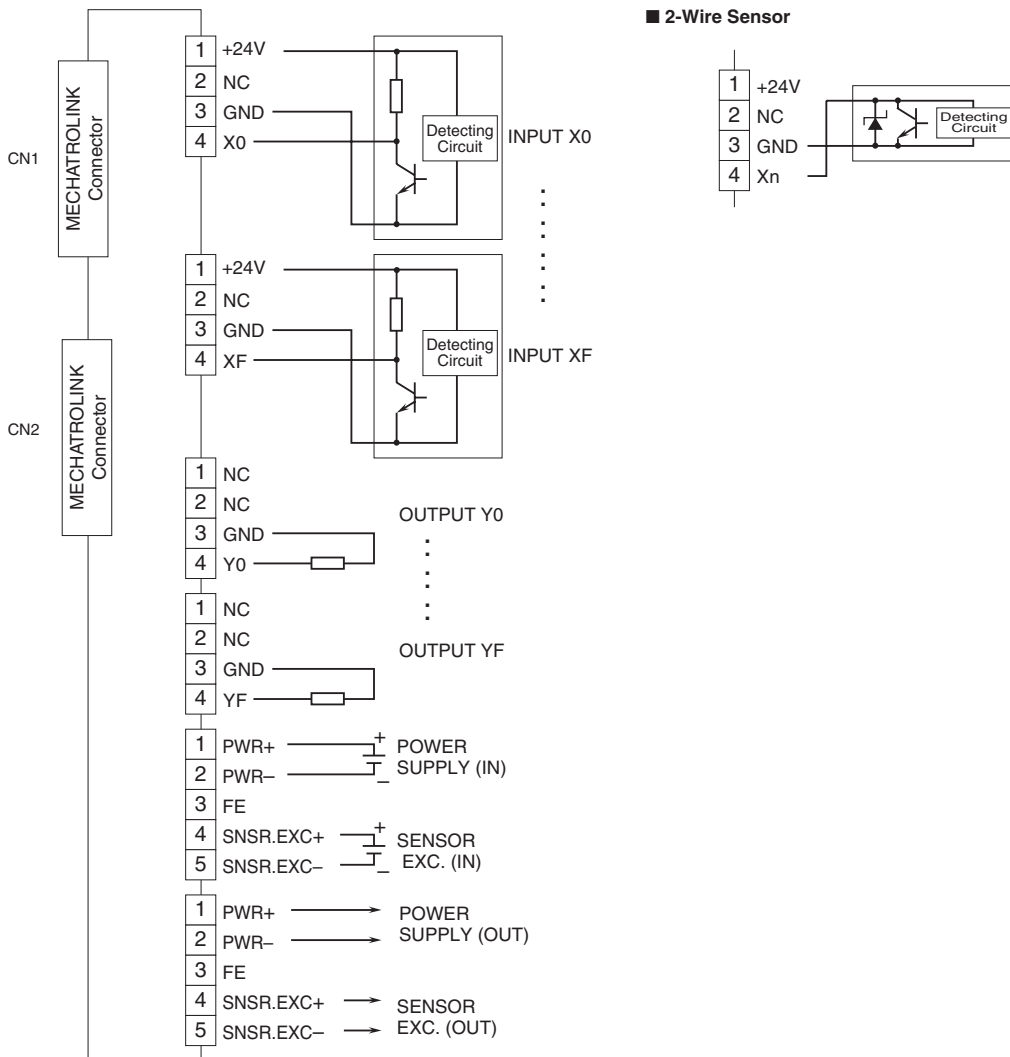

Note: In order to improve EMC performance, bond the FE terminal to the ground.

Caution: FE terminal is NOT a protective conductor terminal.

MECHATROLINK COMMUNICATION

■ MECHATROLINK-I

Baud rate: 4 Mbps

Transmission distance: 50 m max.

Distance between stations: 30 cm min.

Transmission media: MECHATROLINK cable (Model JEPMC-W6003-x-E, Yaskawa Controls Co., Ltd.)

Max. number of slaves: 15

(The maximum number of slaves might change depending on the master unit. Refer to the manual of the master unit.)

Transmission cycle: 2 msec. (fixed)

Data length: 17 byte

■ MECHATROLINK-II

Baud rate: 10 Mbps

Transmission distance: 50 m max.

Distance between stations: 50 cm min.

Transmission media: MECHATROLINK cable (Model JEPMC-W6003-x-E, Yaskawa Controls Co., Ltd.)

Max. number of slaves: 30

(The maximum number of slaves might change depending on the master unit. Refer to the manual of the master unit.)

Transmission cycle: 0.25msec., 0.5 msec., 1 msec., 1.5 msec., 2 msec., 2.5 msec., 3 msec., 4 msec., 8 msec.

Data length: 17 byte / 32 byte selectable (Must choose identical data size for all stations within the network)

MECHATROLINK RELATED COMMANDS

R7K4DML (Simple I/O) communicates with I/O service with no processor, therefore it uses a connectionless communication protocol. There is no application layer either; the R7K4DML interchanges I/O data via data link layer.

■ MECHATROLINK DATA LINK LAYER COMMAND DESCRIPTIONS

The following tables explain the two Commands supported by the R7K4DML.

• MDS Command (04H) Data Format

BYTE	COMMAND	RESPONSE	REMARKS
0	MDS (04H)	S(0) (90H)	Message Data Search (MDS) Command: Read the ID from slave station(s) S(0): Response to MDS
1	0	ID	
2	0		
3	0	0	All 0
4	0	0	
5	0	0	
6	0	0	
7	0	0	
8	0	0	
9	0	0	
10	0	0	
11	0	0	
12	0	0	
13	0	0	
14	0	0	
15	0	0	
16	0	0	
17	0	0	Byte 17 through 31 are always 0 in the 32-byte mode. These bytes are unavailable for MECHATROLINK-I and MECHATROLINK-II in the 17-byte mode.
:	:	:	
31	0	0	

• CDRW Command (03H) Data Format

BYTE	COMMAND	RESPONSE	REMARKS
0	CDRW (03H)	ACK (01H)	Cyclic Data Read/Write (CDRW) Command: Link transmission Acknowledge (ACK): Positive response to CDRW
1	Out Data: Lowest	In Data: Lowest	Order of data: Little Endian
2			
3			
4			
5			
6			
7			
8			
9			
10			
11			
12			
13			
14			
15			
16	Out Data: Highest	In Data: Highest	
17	(Out Data: Highest)	(In Data: Highest)	Byte 17 through 31 are unavailable for MECHATROLINK-I and MECHATROLINK-II in the 17-byte mode. (Only available for MECHATROLINK-II in the 32-byte mode)
:			
31			

I/O DATA DESCRIPTIONS

■ 17-BYTE MODE

•16 points input data

Byte	Bit7	Bit6	Bit5	Bit4	Bit3	Bit2	Bit1	Bit0
1	In7	In6	In5	In4	In3	In2	In1	In0
2	In15	In14	In13	In12	In11	In10	In9	In8
3	0	0	0	0	0	0	0	0
4	0	0	0	0	0	0	0	0
5	0	0	0	0	0	0	0	0
⋮	0	0	0	0	0	0	0	0
12	0	0	0	0	0	0	0	0
13	0	0	0	0	0	0	0	0
14	0	0	0	0	0	0	0	0
15	0	0	0	0	0	0	0	0
16	0	0	0	0	0	0	0	0

•16 points output data

Byte	Bit7	Bit6	Bit5	Bit4	Bit3	Bit2	Bit1	Bit0
1	0	0	0	0	0	0	0	0
2	0	0	0	0	0	0	0	0
3	0	0	0	0	0	0	0	0
4	0	0	0	0	0	0	0	0
5	0	0	0	0	0	0	0	0
⋮	0	0	0	0	0	0	0	0
12	0	0	0	0	0	0	0	0
13	0	0	0	0	0	0	0	0
14	0	0	0	0	0	0	0	0
15	Out7	Out6	Out5	Out4	Out3	Out2	Out1	Out0
16	Out15	Out14	Out13	Out12	Out11	Out10	Out9	Out8

■ 32-BYTE MODE

•16 points input data

Byte	Bit7	Bit6	Bit5	Bit4	Bit3	Bit2	Bit1	Bit0
1	In7	In6	In5	In4	In3	In2	In1	In0
2	In15	In14	In13	In12	In11	In10	In9	In8
3	0	0	0	0	0	0	0	0
4	0	0	0	0	0	0	0	0
5	0	0	0	0	0	0	0	0
⋮	0	0	0	0	0	0	0	0
28	0	0	0	0	0	0	0	0
29	0	0	0	0	0	0	0	0
30	0	0	0	0	0	0	0	0
31	0	0	0	0	0	0	0	0
32	0	0	0	0	0	0	0	0

•16 points output data

Byte	Bit7	Bit6	Bit5	Bit4	Bit3	Bit2	Bit1	Bit0
1	0	0	0	0	0	0	0	0
2	0	0	0	0	0	0	0	0
3	0	0	0	0	0	0	0	0
4	0	0	0	0	0	0	0	0
5	0	0	0	0	0	0	0	0
⋮	0	0	0	0	0	0	0	0
28	0	0	0	0	0	0	0	0
29	0	0	0	0	0	0	0	0
30	0	0	0	0	0	0	0	0
31	Out7	Out6	Out5	Out4	Out3	Out2	Out1	Out0
32	Out15	Out14	Out13	Out12	Out11	Out10	Out9	Out8

0: OFF, 1: ON

At the loss of communication, output is hold. (last data correctly received is hold)