

**BEFORE USE ....**

Thank you for choosing M-System. Before use, please check contents of the package you received as outlined below.

If you have any problems or questions with the product, please contact M-System's Sales Office or representatives.

**■ PACKAGE INCLUDES:**

Discrete input module.....(1)  
Surface mounter slider .....(2)

**■ MODEL NO.**

Confirm Model No. marking on the product to be exactly what you ordered.

**■ INSTRUCTION MANUAL**

This manual describes necessary points of caution when you use this product, including installation, connection and basic maintenance procedures.

**POINTS OF CAUTION****■ CONFORMITY WITH EU DIRECTIVE**

- The equipment must be mounted inside the instrument panel of a metal enclosure.
- The actual installation environments such as panel configurations, connected devices and connected wires may affect the protection level of this unit when it is integrated in a panel system. The user may have to review the CE requirements in regard to the whole system and employ additional protective measures to ensure CE conformity.

**■ POWER INPUT RATING & OPERATIONAL RANGE**

- Locate the power input rating marked on the product and confirm its operational range as indicated below:  
24V DC rating: 24V  $\pm$ 10%, approx. 60mA

**■ REMOVING THE UNIT**

- Before you remove the unit or mount it, turn off the power supply and input signal for safety.

**■ ENVIRONMENT**

- Indoor use.
- When heavy dust or metal particles are present in the air, install the unit inside proper housing with sufficient ventilation.
- Do not install the unit where it is subjected to continuous vibration. Do not subject the unit to physical impact.
- Environmental temperature must be within 0 to +55°C (32 to 131°F) with relative humidity within 30 to 90% RH in order to ensure adequate life span and operation.

**■ WIRING**

- Do not install cables close to noise sources (relay drive cable, high frequency line, etc.).
- Do not bind these cables together with those in which noises are present. Do not install them in the same duct.

**■ AND ....**

- The unit is designed to function as soon as power is supplied, however, a warm up for 10 minutes is required for satisfying complete performance described in the data sheet.

# COMPONENT IDENTIFICATION

## FRONT VIEW

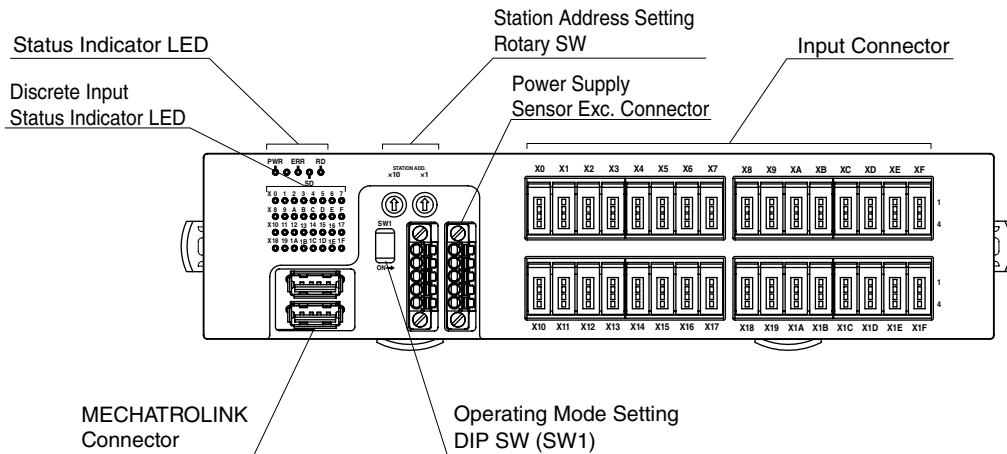

### STATUS INDICATOR LED

ID	COLOR	FUNCTION
PWR	Green	Turns on when internal power is supplied normally, and off with internal power failure.
ERR	Red	Turns on with station address setting error, and off with normal station address setting.
SD	Green	Turns on when transmitting data, and off when not transmitting data.
RD	Green	Turns on when receiving data, and off when not receiving data.

### DISCRETE INPUT STATUS INDICATOR LED

LED green indicators show each input signal status.

- ON : LED ON
- OFF : LED OFF

### STATION ADDRESS

The left switch determines the upper digit, while the right switch does the lower digit of the station address (hexadecimal number).

(Range: 60H to 7FH)\*

(Factory setting: 61H)

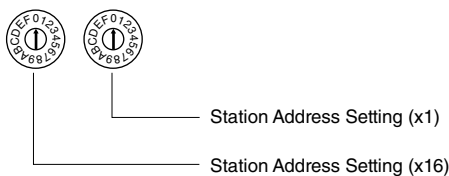

\* As R7K4DML is simple I/O, set the station address within the range from 60H to 7FH.

Refer to the instruction manual of the master unit for unselectable addresses, which depending on master unit types.

### MECHATROLINK MODE

Set either MECHATROLINK-I or -II, and the data size with SW1-1 and SW1-2.

SW1-1	SW1-2	MECHATROLINK
OFF	OFF	MECHATROLINK-II (32 byte mode) (*)
ON	OFF	MECHATROLINK-II (17 byte mode)
ON	ON	MECHATROLINK-I (17 byte mode)

(\*) Factory setting

Note : Be sure to set unused SW1-3 and 1-4 to OFF.

### POWER SUPPLY, SENSOR EXCITATION

**Cable connector:** FMC1,5 / 5-STF-3,5

(Phoenix Contact) (included in the package)

**Applicable wire size:** 0.2 – 1.5 mm<sup>2</sup>; stripped length 10 mm

**Recommended solderless terminal**

- A10,25-10YE 0.25 mm<sup>2</sup> (Phoenix Contact)
- A10,34-10TQ 0.34 mm<sup>2</sup> (Phoenix Contact)
- A10,5-10WH 0.5 mm<sup>2</sup> (Phoenix Contact)
- A10,75-10GY 0.75 mm<sup>2</sup> (Phoenix Contact)
- A1-10 1.0 mm<sup>2</sup> (Phoenix Contact)
- A1,5-10 1.5 mm<sup>2</sup> (Phoenix Contact)

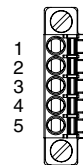

- 1. PWR+ Power Supply (24 V DC)
- 2. PWR- Power Supply (0 V)
- 3. FE Functional earth
- 4. SNSR.EXC+ Sensor excitation (24 V DC)
- 5. SNSR.EXC- Sensor excitation (0 V)

■ TERMINAL ASSIGNMENTS

• I/O Connection

Recommended cable connector: 37104-( )-000FL (3M Company)

(The cable connector is not included in the package. Specify wire size instead of ( ); refer to the specifications of the product.)

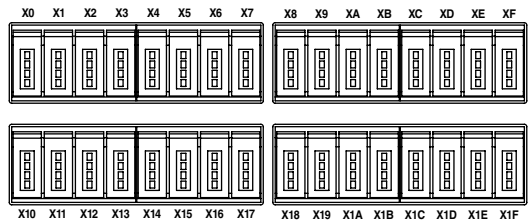

No.	ID	FUNCTION	No.	ID	FUNCTION
X0	1	+24V 24V DC	X8	1	+24V 24V DC
	2	NC Unused		2	NC Unused
	3	GND 0V		3	GND 0V
	4	X0 Input 0		4	X8 Input 8
X1	1	+24V 24V DC	X9	1	+24V 24V DC
	2	NC Unused		2	NC Unused
	3	GND 0V		3	GND 0V
	4	X1 Input 1		4	X9 Input 9
X2	1	+24V 24V DC	XA	1	+24V 24V DC
	2	NC Unused		2	NC Unused
	3	GND 0V		3	GND 0V
	4	X2 Input 2		4	XA Input 10
X3	1	+24V 24V DC	XB	1	+24V 24V DC
	2	NC Unused		2	NC Unused
	3	GND 0V		3	GND 0V
	4	X3 Input 3		4	XB Input 11
X4	1	+24V 24V DC	XC	1	+24V 24V DC
	2	NC Unused		2	NC Unused
	3	GND 0V		3	GND 0V
	4	X4 Input 4		4	XC Input 12
X5	1	+24V 24V DC	XD	1	+24V 24V DC
	2	NC Unused		2	NC Unused
	3	GND 0V		3	GND 0V
	4	X5 Input 5		4	XD Input 13
X6	1	+24V 24V DC	XE	1	+24V 24V DC
	2	NC Unused		2	NC Unused
	3	GND 0V		3	GND 0V
	4	X6 Input 6		4	XE Input 14
X7	1	+24V 24V DC	XF	1	+24V 24V DC
	2	NC Unused		2	NC Unused
	3	GND 0V		3	GND 0V
	4	X7 Input 7		4	XF Input 15

No.	ID	FUNCTION	No.	ID	FUNCTION
X10	1	+24V 24V DC	X18	1	+24V 24V DC
	2	NC Unused		2	NC Unused
	3	GND 0V		3	GND 0V
	4	X10 Input 16		4	X18 Input 24
X11	1	+24V 24V DC	X19	1	+24V 24V DC
	2	NC Unused		2	NC Unused
	3	GND 0V		3	GND 0V
	4	X11 Input 17		4	X19 Input 25
X12	1	+24V 24V DC	X1A	1	+24V 24V DC
	2	NC Unused		2	NC Unused
	3	GND 0V		3	GND 0V
	4	X12 Input 18		4	X1A Input 26
X13	1	+24V 24V DC	X1B	1	+24V 24V DC
	2	NC Unused		2	NC Unused
	3	GND 0V		3	GND 0V
	4	X13 Input 19		4	X1B Input 27
X14	1	+24V 24V DC	X1C	1	+24V 24V DC
	2	NC Unused		2	NC Unused
	3	GND 0V		3	GND 0V
	4	X14 Input 20		4	X1C Input 28
X15	1	+24V 24V DC	X1D	1	+24V 24V DC
	2	NC Unused		2	NC Unused
	3	GND 0V		3	GND 0V
	4	X15 Input 21		4	X1D Input 29
X16	1	+24V 24V DC	X1E	1	+24V 24V DC
	2	NC Unused		2	NC Unused
	3	GND 0V		3	GND 0V
	4	X16 Input 22		4	X1E Input 30
X17	1	+24V 24V DC	X1F	1	+24V 24V DC
	2	NC Unused		2	NC Unused
	3	GND 0V		3	GND 0V
	4	X17 Input 23		4	X1F Input 31

■ MECHATROLINK CONNECTION

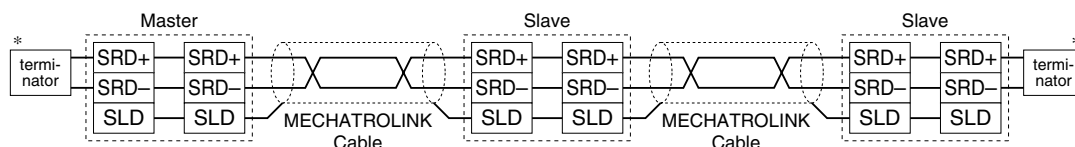

\*Terminator

Be sure to connect the terminating resistors to the unit at both ends of transmission line.

Use the terminating resistor for MECHATROLINK: Model JEPMC-W6022, Yaskawa Controls Co., Ltd.

Certain types of Master units may have incorporated terminating resistors. Consult the instruction manual for the Master.

## MOUNTING INSTRUCTIONS

### ■ DIN RAIL MOUNTING

#### • Mounting

- 1) Set the upper hook at the rear side of the unit on the DIN rail.
- 2) Push in the lower.

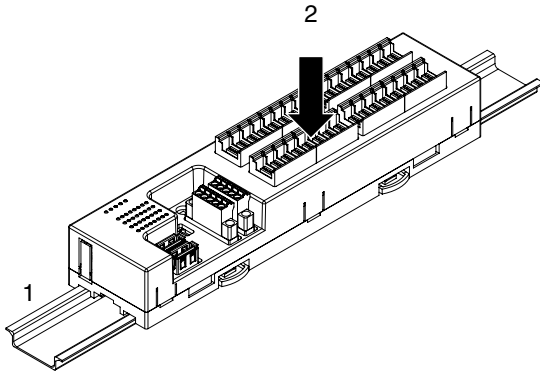

#### • Dismounting

- 1) Push down the DIN rail mouter slider with the tip of a minus screwdriver.
- 2) Pull the lower of the unit.
- 3) Remove the upper hook of the unit from the DIN rail.

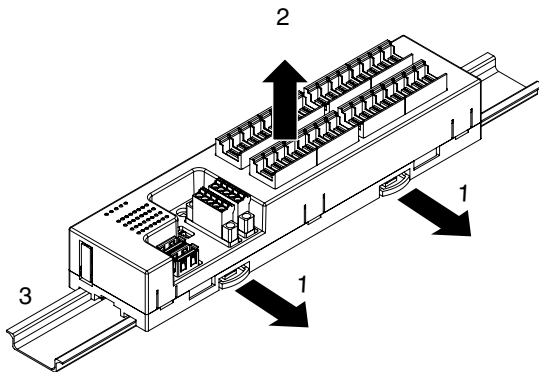

### ■ SURFACE MOUNTING

- 1) Insert the two DIN rail mouter sliders until it clicks once, as shown below.

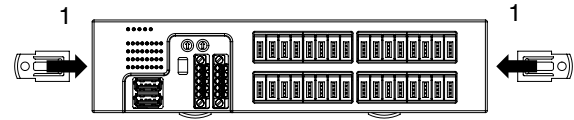

- 2) Mount the unit with M4 screws referring to the EXTERNAL DIMENSIONS. (Torque: 1.4 N·m)

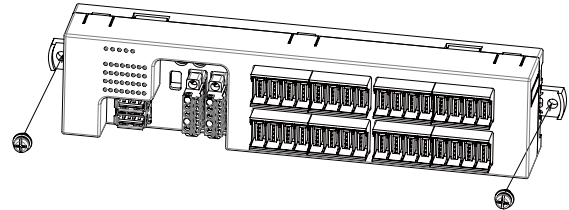

## MOUNTING REQUIREMENTS unit: mm (inch)

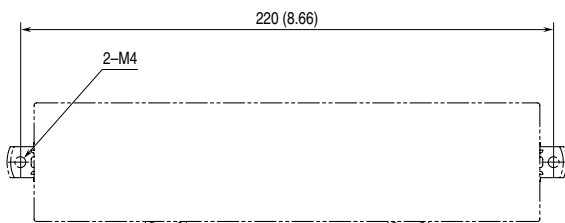

# TERMINAL CONNECTIONS

Connect the unit as in the diagram below.

## EXTERNAL DIMENSIONS unit : mm (inch)

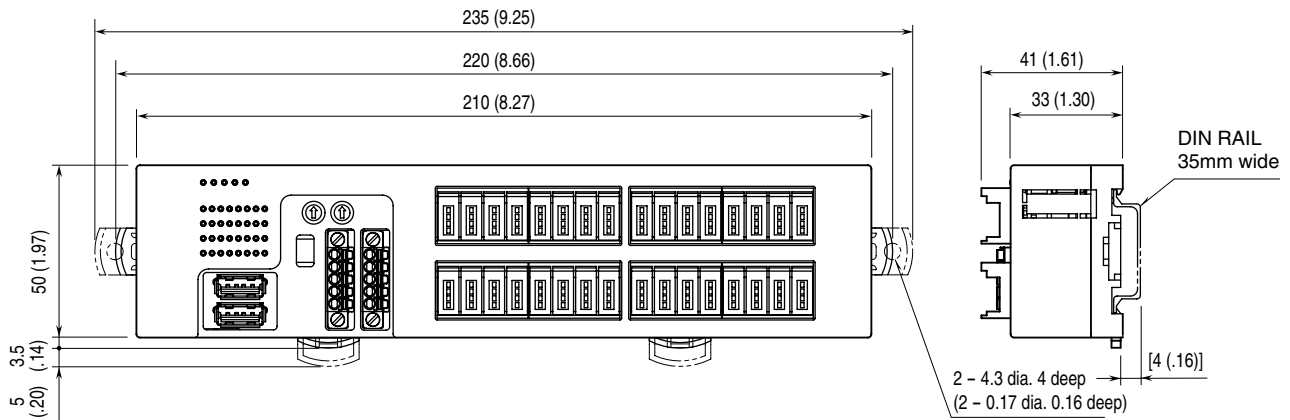

## CONNECTION DIAGRAM

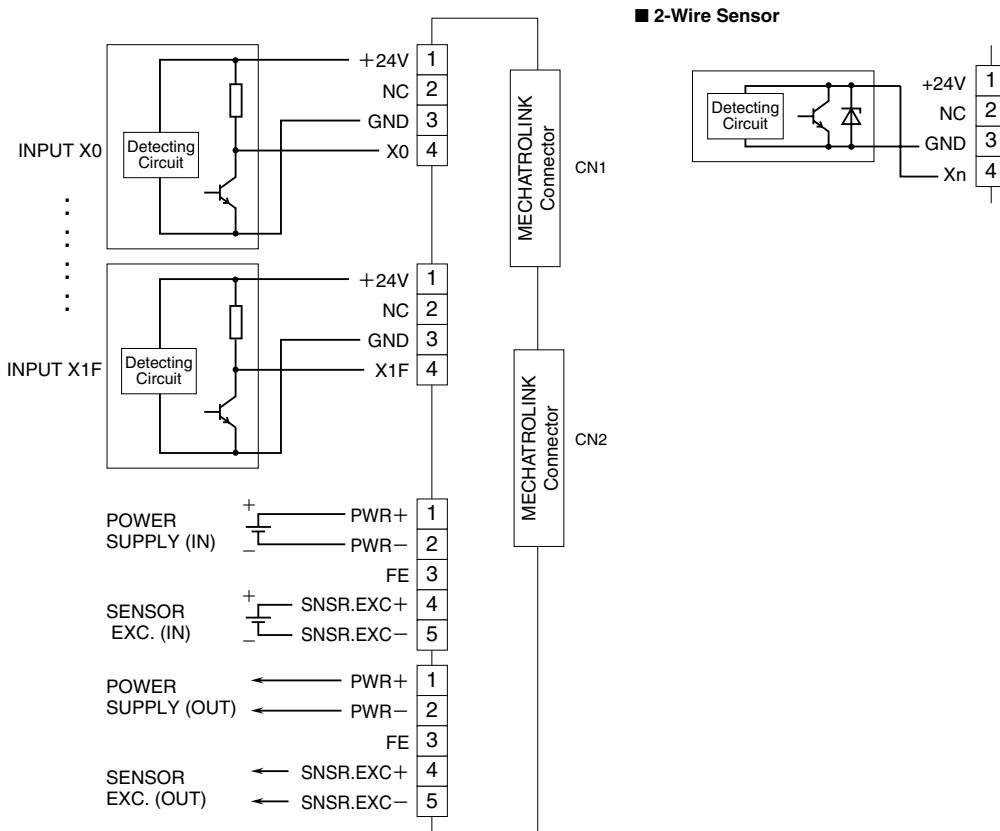

Note: In order to improve EMC performance, bond the FE terminal to the ground.

Caution: FE terminal is NOT a protective conductor terminal.

---

## MECHATROLINK COMMUNICATION

### ■ MECHATROLINK-I

Baud rate: 4 Mbps

Transmission distance: 50 m max.

Distance between stations: 30 cm min.

Transmission media: MECHATROLINK cable (Model JEPMC-W6003-x-E, Yaskawa Controls Co., Ltd.)

Max. number of slaves: 15

(The maximum number of slaves might change depending on the master unit. Refer to the manual of the master unit.)

Transmission cycle: 2 msec. (fixed)

Data length: 17 byte

### ■ MECHATROLINK-II

Baud rate: 10 Mbps

Transmission distance: 50 m max.

Distance between stations: 50 cm min.

Transmission media: MECHATROLINK cable (Model JEPMC-W6003-x-E, Yaskawa Controls Co., Ltd.)

Max. number of slaves: 30

(The maximum number of slaves might change depending on the master unit. Refer to the manual of the master unit.)

Transmission cycle: 0.25 msec., 0.5 msec., 1 msec., 1.5 msec., 2 msec., 2.5 msec., 3 msec., 4 msec., 8 msec.

Data length: 17 byte / 32 byte selectable (Must choose identical data size for all stations within the network)

## MECHATROLINK RELATED COMMANDS

R7K4DML (Simple I/O) communicates with I/O service with no processor, therefore it uses a connectionless communication protocol. There is no application layer either; the R7K4DML interchanges I/O data via data link layer.

### MECHATROLINK DATA LINK LAYER COMMAND DESCRIPTIONS

The following tables explain the two Commands supported by the R7K4DML.

#### • MDS Command (04H) Data Format

BYTE	COMMAND	RESPONSE	REMARKS
0	MDS (04H)	S(0) (90H)	Message Data Search (MDS) Command: Read the ID from slave station(s) S(0): Response to MDS
1	0	ID	
2	0		
3	0	0	All 0
4	0	0	
5	0	0	
6	0	0	
7	0	0	
8	0	0	
9	0	0	
10	0	0	
11	0	0	
12	0	0	
13	0	0	
14	0	0	
15	0	0	
16	0	0	
17	0	0	Byte 17 through 31 are always 0 in the 32-byte mode. These bytes are unavailable for MECHATROLINK-I and MECHATROLINK-II in the 17-byte mode.
:	:	:	
31	0	0	

#### • CDRW Command (03H) Data Format

BYTE	COMMAND	RESPONSE	REMARKS
0	CDRW (03H)	ACK (01H)	Cyclic Data Read/Write (CDRW) Command: Link transmission Acknowledge (ACK): Positive response to CDRW
1	Out Data: Lowest	In Data: Lowest	Order of data: Little Endian
2			
3			
4			
5			
6			
7			
8			
9			
10			
11			
12			
13			
14			
15			
16	Out Data: Highest	In Data: Highest	
17			Byte 17 through 31 are unavailable for MECHATROLINK-I and MECHATROLINK-II in the 17-byte mode. (Only available for MECHATROLINK-II in the 32-byte mode)
:			
31	(Out Data: Highest)	(In Data: Highest)	

## I/O DATA DESCRIPTIONS

### ■ 17-BYTE MODE

#### • 32 points input data (In Data)

Byte	Bit7	Bit6	Bit5	Bit4	Bit3	Bit2	Bit1	Bit0
1	In7	In6	In5	In4	In3	In2	In1	In0
2	In15	In14	In13	In12	In11	In10	In9	In8
3	In23	In22	In21	In20	In19	In18	In17	In16
4	In31	In30	In29	In28	In27	In26	In25	In24
5	0	0	0	0	0	0	0	0
⋮	0	0	0	0	0	0	0	0
12	0	0	0	0	0	0	0	0
13	0	0	0	0	0	0	0	0
14	0	0	0	0	0	0	0	0
15	0	0	0	0	0	0	0	0
16	0	0	0	0	0	0	0	0

### ■ 32-BYTE MODE

#### • 32 points input data (In Data)

Byte	Bit7	Bit6	Bit5	Bit4	Bit3	Bit2	Bit1	Bit0
1	In7	In6	In5	In4	In3	In2	In1	In0
2	In15	In14	In13	In12	In11	In10	In9	In8
3	In23	In22	In21	In20	In19	In18	In17	In16
4	In31	In30	In29	In28	In27	In26	In25	In24
5	0	0	0	0	0	0	0	0
⋮	0	0	0	0	0	0	0	0
12	0	0	0	0	0	0	0	0
13	0	0	0	0	0	0	0	0
14	0	0	0	0	0	0	0	0
15	0	0	0	0	0	0	0	0
16	0	0	0	0	0	0	0	0

0: OFF, 1: ON