

NPN TRANSISTOR OUTPUT MODULE

(16 points,MECHATROLINK-III)

MODEL R7G4FML3-6-DC16A

BEFORE USE

Thank you for choosing M-System. Before use, please check contents of the package you received as outlined below.

If you have any problems or questions with the product, please contact M-System's Sales Office or representatives.

The unit is for use in general industrial environments, therefore may not be suitable for applications which require higher level of safety (e.g. safety or accident prevention systems) or of reliability (e.g. vehicle control or combustion control systems).

For safety, installation and maintenance of this unit must be conducted by qualified personnel.

■ PACKAGE INCLUDES:

- Transistor output module (1)
DIN rail mounter slider (2)

■ MODEL NO.

Confirm that the model number described on the product is exactly what you ordered.

■ INSTRUCTION MANUAL

This manual describes necessary points of caution when you use this product, including installation, connection and basic maintenance procedures.

■ SYMBOLS USED ON THE PRODUCT



Functional earth symbol is marked on terminal cover of Power Supply Terminals for UL.

POINTS OF CAUTION

■ CAUTION

- If the unit is not used in a manner not specified by M-system, the protection provided by the equipment may be impaired.

■ CONFORMITY WITH EU DIRECTIVES OR UL

- The actual installation environments such as panel configurations, connected devices and connected wires may affect the protection level of this unit when it is integrated in a panel system. The user may have to review the CE requirements in regard to the whole system and employ additional protective measures to ensure CE conformity.
- This unit is suitable for Pollution Degree 2.
- Altitude up to 2000 meters.
- The power supply and the external power supply must satisfy SELV requirements in accordance with currently applicable safety standards. (SELV = Safety Extra Low Voltage).
- Install inside an industrial control panel or equivalent for UL.

■ POWER INPUT RATING & OPERATIONAL RANGE

- Locate the power input rating marked on the product and confirm its operational range as indicated below:
24V DC rating: 24V \pm 10%, approx. 80mA

■ GENERAL PRECAUTIONS

- Before you remove the unit or mount it, turn off the power supply and output signal for safety.
- Before you remove the terminal block or mount it, turn off the power supply and output signal for safety.

■ ENVIRONMENT

- Indoor use
- When heavy dust or metal particles are present in the air, install the unit inside proper housing with sufficient ventilation.
- Do not install the unit where it is subjected to continuous vibration. Do not subject the unit to physical impact.
- Environmental temperature must be within -10 to 55°C (14 to 131°F) with relative humidity within 30 to 90% RH in order to ensure adequate life span and operation.

■ WIRING

- Do not install cables close to noise sources (relay drive cable, high frequency line, etc.).
- Do not bind these cables together with those in which noises are present. Do not install them in the same duct.
- Be sure to close the terminal cover for safety.

■ OUTPUT TERMINAL

- The current to output terminal cannot exceed the rated current even when the external power supply is normal operating conditions and single fault conditions. Otherwise it will impair prescribed performance and cause burning of the equipment itself.

■ AND

- The unit is designed to function as soon as power is supplied, however, a warm up for 10 minutes is required for satisfying complete performance described in the data sheet.

FRONT VIEW

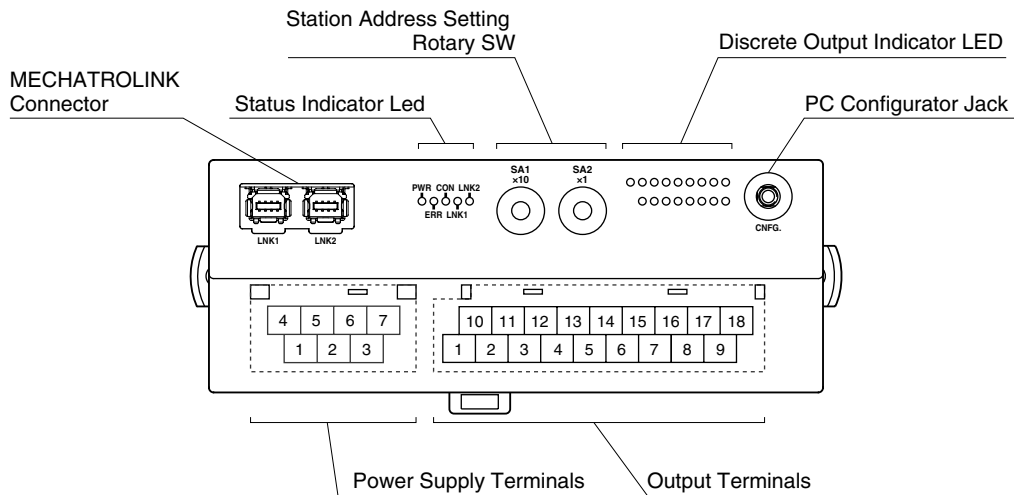

■ STATUS INDICATOR LED

ID	COLOR	FUNCTION
PWR	Green	Turns on when the internal power is supplied normally.
ERR	Red	Turns on at MECHATROLINK-III communication error
CON	Green	Turns on at MECHATROLINK-III connection is established
LNK1	Green	Turns on at MECHATROLINK-III LNK1 is established
LNK2	Green	Turns on at MECHATROLINK-III LNK2 is established

■ STATION ADDRESS

Station Address is selected between 03H and EFH in hexadecimal.

The SA1 switch determines the MSD, while the SA2 switch does the LSD of the address.

(Factory setting: 03H)



Station Address Setting (x1)

Station Address Setting (x10)

■ PC CONFIGURATOR JACK

The PC Configurator is used to set the following parameters for each channel.

Communication Cutoff Output Settings

- Output clear (Output OFF)
- Output hold (Previous normal reception data hold) (*)

For more information about the programming using the R7CFG, please refer to the R7CFG Users Manual.

(*) Factory setting

■ DISCRETE OUTPUT STATUS INDICATOR LED

Discrete output module displays the status of each output with an LED (green).

Contact ON : LED ON

Contact OFF : LED OFF

■ POWER SUPPLY TERMINAL ASSIGNMENT

4	5	6	7
NC	NC	+24V	0V
1	2	3	
NC	NC	FE	

- | | |
|---------|-----------------------|
| 1. NC | - |
| 2. NC | - |
| 3. FE | Functional earth |
| 4. NC | - |
| 5. NC | - |
| 6. +24V | Power supply (24V DC) |
| 7. 0V | Power supply (0V) |

■ OUTPUT TERMINAL ASSIGNMENTS

10	11	12	13	14	15	16	17	18
V+	Y1	Y3	Y5	Y7	Y9	Y11	Y13	Y15
1	2	3	4	5	6	7	8	9
V-	Y0	Y2	Y4	Y6	Y8	Y10	Y12	Y14

NO.	ID	FUNCTION	NO.	ID	FUNCTION
1	V-	0V (Out. Common)	10	V+	24VDC
2	Y0	Output 0	11	Y1	Output 1
3	Y2	Output 2	12	Y3	Output 3
4	Y4	Output 4	13	Y5	Output 5
5	Y6	Output 6	14	Y7	Output 7
6	Y8	Output 8	15	Y9	Output 9
7	Y10	Output 10	16	Y11	Output 11
8	Y12	Output 12	17	Y13	Output 13
9	Y14	Output 14	18	Y15	Output 15

MOUNTING INSTRUCTIONS

■ DIN RAIL MOUNTING (PARALLEL)

• Mounting

- 1) Set the upper hook at the rear side of the unit on the DIN rail.
- 2) Push in the lower.

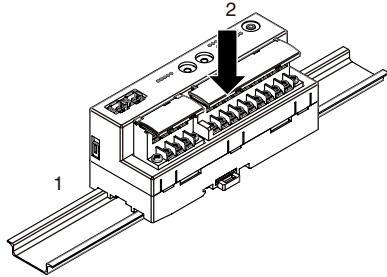

• Dismounting

- 1) Push down the DIN rail mounter slider with tip of a minus screwdriver.
- 2) Pull the lower of the unit.
- 3) Remove the upper hook of the unit from the DIN rail.

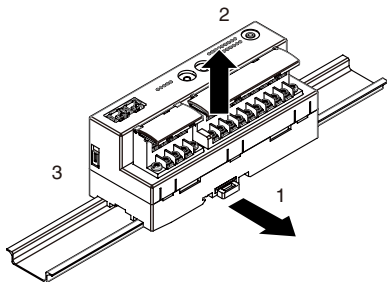

■ SURFACE MOUNTING

- 1) Insert the two DIN rail mounter sliders until it clicks once, as shown below.

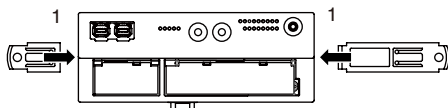

- 2) Mount the unit with M4 screws referring the External Dimensions. (Torque: 1.4 N·m)

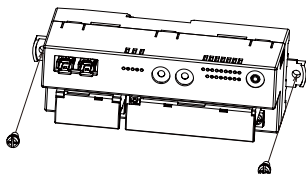

■ DIN RAIL MOUNTING (RIGHT ANGLE)

• Mounting

- 1) Insert the longer DIN rail mounter slider until it clicks twice, as shown below.

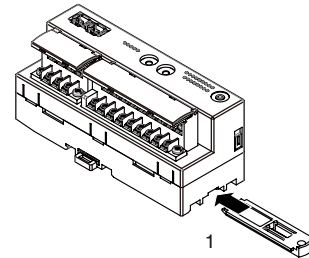

- 2) Set the upper hook at the rear side of the unit on the DIN rail.
- 3) Push in the lower.

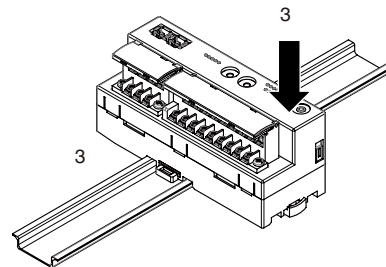

• Dismounting

- 1) Push down the DIN rail mounter slider with tip of a minus screwdriver.
- 2) Pull the lower of the unit.
- 3) Remove the upper hook of the unit from the DIN rail.

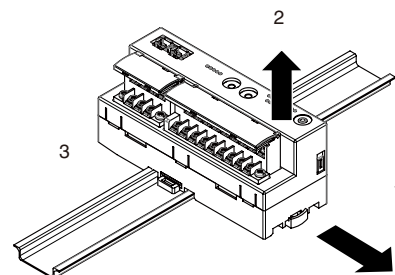

EXTERNAL DIMENSIONS unit: mm (inch)

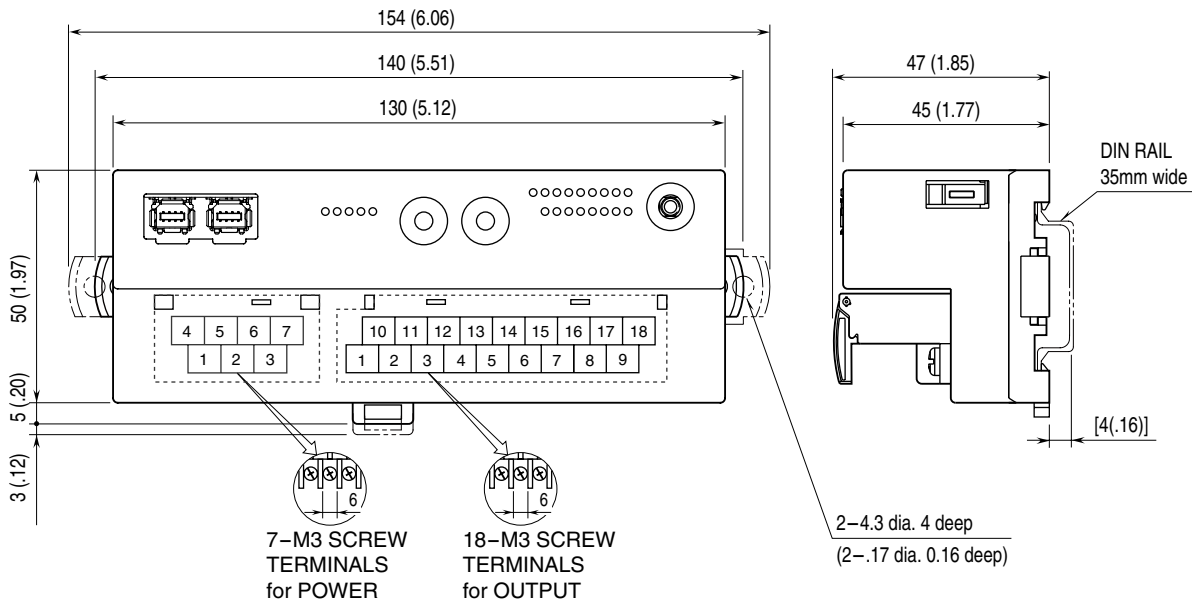

CONNECTION DIAGRAM

Connect the unit as in the diagram below.

Note: In order to improve EMC performance, bond the FE terminal to ground.

Caution: FE terminal is NOT a protective conductor terminal.

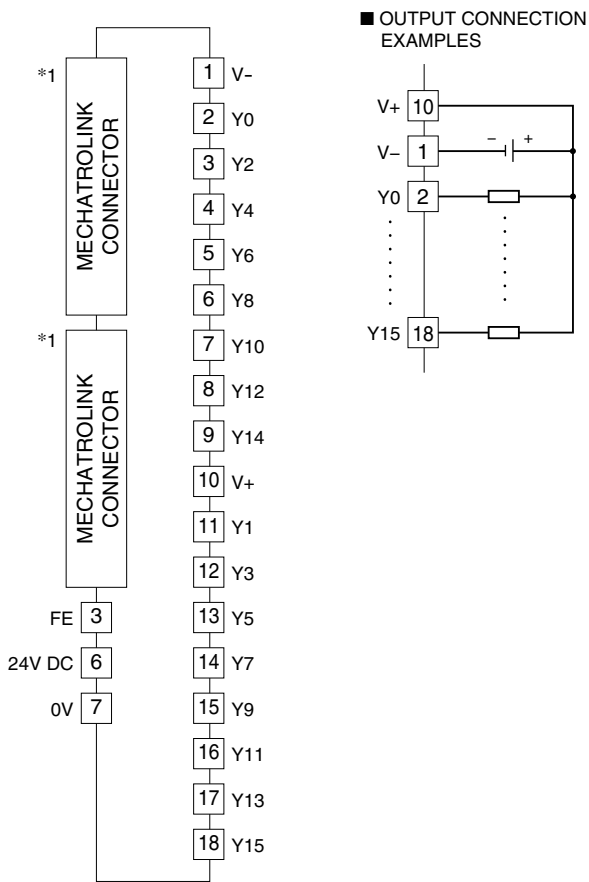

*1. The network cable can be connected to either one.

MOUNTING REQUIREMENTS unit: mm (inch)

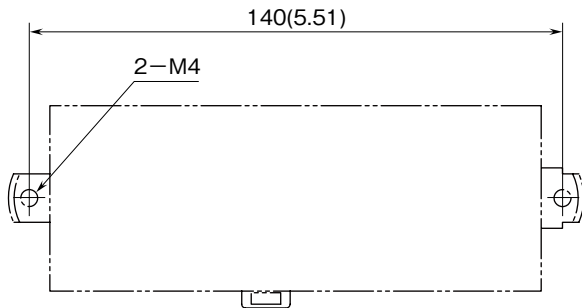

WIRING INSTRUCTIONS

■ TORQUE

Wiring screw for separable terminal: 0.5 N m
Fixing screw for separable terminal: 0.5 N m

■ SOLDERLESS TERMINAL mm (inch)

Refer to the drawing below for recommended ring tongue terminal size. Spade tongue type is also applicable. Solderless terminals with insulation sleeve do not fit.

- Recommended manufacturer: Japan Solderless Terminal MFG.Co.Ltd, Nichifu Co.,ltd
- Applicable wire size: 0.25 – 1.65 mm² (AWG 22 – 16)

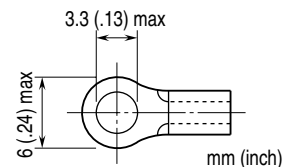

■ HOW TO UNMOUNT THE SEPARABLE TERMINAL

The separable terminal of the unit is 2 piece constructions. It is possible to remove the terminal by loosening two screws of terminal alternately.

MECHATROLINK-III COMMUNICATION

Transmission cycle: 125 μsec., 250 μsec., 500 μsec., 1 – 64 msec. (with 1 msec. increments)

Communication cycle: 125 μsec. through 64 msec.

Applicable profile: Standard I/O profile (cyclic communication)

Event-driven communication acquiring ID profile (event-driven communication)

Data size: 16 bytes

Station address: 03H through EFH (set with rotary switches)

Cyclic communication: Available

Event-driven communication: Available

Slave monitoring: None

MECHATROLINK-III COMMAND

Commands available with this unit are the following.

PROFILE	COMMAND	CODE	FUNCTION
Common command	NOP	00H	No operation command
	ID_RD	03H	Read ID command
	CONFIG	04H	Setup device command
	ALM_RD	05H	Read alarm or warning command
	ALM_CLR	06H	Clear alarm or warning command
	CONNECT	0EH	Establish connection command
	DISCONNECT	0FH	Release Connection command
Standard I/O command	DATA_RWA	20H	Transmit I/O data

• NOP (00H)

Does nothing except sending back current status

BYTE	COMMAND	RESPONSE	REMARKS
0	NOP (00H)	NOP (00H)	No operation command
1	00H	00H	Not used
2	CMD_CTRL	CMD_STAT	Refer to CMD_CTRL/CMD_STAT.
3			
≥ 4	00H	00H	Reserve

• **ID_RD (03H)**

Reads the product ID.

BYTE	COMMAND	RESPONSE	REMARKS
0	ID_RD (03H)	ID_RD (03H)	Read ID command
1	00H	00H	Not used
2	CMD_CTRL	CMD_STAT	Refer to CMD_CTRL/CMD_STAT.
3			
4	ID_CODE	ID_CODE	Refer to ID_CODE
5	OFFSET	OFFSET	OFFSET: designates the place to read data
6	SIZE	SIZE	SIZE: specify the size of data to read
7			
≥ 8	00H	ID	Product's ID

• **CONFIG (04H)**

No parameter to set for this unit. Immediately response with completion.

BYTE	COMMAND	RESPONSE	REMARKS
0	CONFIG (04H)	CONFIG (04H)	Setup device command
1	00H	00H	Not used
2	CMD_CTRL	CMD_STAT	Refer to CMD_CTRL/CMD_STAT.
3			
4	00H	00H	Recalculation of parameters and set up. Other than 00H is not supported.
≥ 5	00H	00H	Reserve

• **ALM_RD (05H)**

Reads alarm or warning

BYTE	COMMAND	RESPONSE	REMARKS
0	ALM_RD (05H)	ALM_RD (05H)	Read alarm or warning command
1	00H	00H	Not used
2	CMD_CTRL	CMD_STAT	Refer to CMD_CTRL/CMD_STAT.
3			
4	0000H	0000H	Read current alarm or warning. 12 points max. (2 bytes in 8th to 31st byte) Other than 00H is not available.
5			
6	0000H	0000H	0
7			
≥ 8	00H	00H	0

• **ALM_CLR (06H)**

Clears alarm or warning

BYTE	COMMAND	RESPONSE	REMARKS
0	ALM_CLR (06H)	ALM_CLR (06H)	Clear alarm or warning command
1	00H	00H	Not used
2	CMD_CTRL	CMD_STAT	Refer to CMD_CTRL/CMD_STAT.
3			
4	0000H	0000H	Clear current alarm or warning. Other than 00H is not available.
5			
≥ 6	00H	00H	Reserve

• **CONNECT (0EH)**

Starts communication with master station.

BYTE	COMMAND	RESPONSE	REMARKS
0	CONNECT (0EH)	CONNECT (0EH)	Establish connection command
1	00H	00H	Not used
2	CMD_CTRL	CMD_STAT	Refer to CMD_CTRL/CMD_STAT.
3			
4	30H	30H	MECHATROLINK application layer: 30H
5	00H	00H	Communication mode: Asynchronous, single transmission, subcommand disabled
6	COM_TIME	COM_TIME	Communication cycle: Multiple of transmission cycle. E.g. Transmission cycle: 0.5 msec, communication cycle: 2 msec. Set 4 (=2/0.5)
7	30H or 01H	30H or 01H	Profile type 30H: Standard I/O 01H: Event-driven
≥ 8	00H	00H	Reserve

• **DISCONNECT (0FH)**

Stops communication with master station.

BYTE	COMMAND	RESPONSE	REMARKS
0	DISCONNECT (0FH)	DISCONNECT (0FH)	Release Connection command
≥ 1	00H	00H	Reserve

• **DATA_RWA (20H)**

Transmits I/O data to master station. Data allocation is following.

Data size is 16 bytes.

BYTE	COMMAND	RESPONSE	REMARKS
0	DATA_RWA (20H)	DATA_RWA (20H)	Transmit I/O data
1	00H	00H	Not used
2	CMD_CTRL	CMD_STAT	Refer to CMD_CTRL/CMD_STAT.
3			
4	CH0 OUT LO	CH0 IN LO	CH x OUT: Output data (Refer to “ Output Data ” under Input / Output Data Details) CHx IN: Input data (Refer to “ Input Data ” under Input /Output Data Details)
5	CH0 OUT HI	CH0 IN HI	
6	CH1 OUT LO	CH1 IN LO	
7	CH1 OUT HI	CH1 IN HI	
8	CH2 OUT LO	CH2 IN LO	
9	CH2 OUT HI	CH2 IN HI	
10	CH3 OUT LO	CH3 IN LO	
11	CH3 OUT HI	CH3 IN HI	
12	00H	00H	Not used
13	00H	00H	Not used
14	00H	00H	Not used
15	00H	00H	Not used

• Input /Output Data Details

Input Data: Slave stations -> master station readback value is set.

CH0 IN LO	CH0 Data Low order 8 bits	Output data readback data bits 0 - 7 are set.
CH0 IN HI	CH0 Data High order 8 bits	Output data readback data bits 8 - 15 are set.
CH1 IN LO	CH1 Data Low order 8 bits	Not in use
CH1 IN HI	CH1 Data High order 8 bits	Not in use
CH2 IN LO	CH2 Data Low order 8 bits	Not in use
CH2 IN HI	CH2 Data High order 8 bits	Not in use
CH3 IN LO	CH3 Data Low order 8 bits	Not in use
CH3 IN HI	CH3 Data High order 8 bits	Not in use

Output Data: Master station -> slave stations data is set.

CH0 OUT LO	CH0 Data Low order 8 bits	Output data bits 0 - 7 are set.
CH0 OUT HI	CH0 Data High order 8 bits	Output data bits 8 - 15 are set.
CH1 OUT LO	CH1 Data Low order 8 bits	Not in use
CH1 OUT HI	CH1 Data High order 8 bits	Not in use
CH2 OUT LO	CH2 Data Low order 8 bits	Not in use
CH2 OUT HI	CH2 Data High order 8 bits	Not in use
CH3 OUT LO	CH3 Data Low order 8 bits	Not in use
CH3 OUT HI	CH3 Data High order 8 bits	Not in use

CMD_CTRL

CMD_CTRL command area is following.

BIT	FUNCTION	REMARKS
0 - 2	Reserve	Not used
3	ALM_CLR	0: Clear alarm/warning disabled 1: Clear alarm/warning triggered
4 - 5	Reserve	Not used
6 - 7	CMD_ID	Not used in the standard I/O command profile
8 - 15	Reserve	Not used

CMD_STAT

CMD_STAT response area is following.

BIT	FUNCTION	REMARKS
0	D_ALM	Not used
1	D_WAR	Not used
2	CMDRDY	1: Command reception enabled 0: Other
3	ALM_CLR_CMP	1: Completion of execution of ALM_CLR 0: Other ALM_CLR_CMP can be cancelled by setting "0" for CMD_CTRL.ALM_CLR.
4 - 5	Reserve	Not used
6 - 7	RCMD_ID	Not used in the standard I/O command profile
8 - 11	CMD_ALM	Warning 0: Normal, 1: Invalid data Alarm 8: Unsupported command received, 9: Invalid data, A: Command execution condition error, B: Subcommand combination error, C: Phase error
12 - 15	COMM_ALM	Warning 0: Normal, 1: FCS error, 2: Command data not received, 3: Synchronous frame not received Alarm 8: FCS error, 9: Command data not received, A: Synchronous frame not received, B: Synchronization time interval error, C: WDT error

ID_CODE

ID_CODE is following.

ID_CODE (HEX.)	NAME	SIZE (BYTES)	SUP-PORT	VALUE (HEXADECIMAL)	REMARKS
01	Vendor ID Code	4	Yes	0x00000021	M-SYSTEM CO., LTD.
02	Device Code	4	Yes	0x00000208	R7G4FML3-6-DC16A
03	Device Version	4	Yes	Firmware version	E.g. 1.00 -> 0x0064
04	Device Definition File version	4	Yes	0x00001000	
05	Extended Address Setting	4	Yes	0x00000001	
06	Serial No.	32	Yes	Unit serial number	E.g. AB123456-> 0x32314241 0x36353433 0x00000000 0x00000000 0x00000000 0x00000000 0x00000000 0x00000000
10	Profile Type 1	4	Yes	0x00000030	Standard I/O profile
11	Profile Version 1	4	Yes	0x00000100	
12	Profile Type 2	4	Yes	0x000000FF	Indicates the unit does not support
13	Profile Version 2	4	Yes	0x00000000	
14	Profile Type 3	4	Yes	0x000000FF	Indicates the unit does not support
15	Profile Version 3	4	Yes	0x00000000	
16	Min.Transmission Cycle	4	Yes	0x000030D4	125 µsec.
17	Max.Transmission Cycle	4	Yes	0x0061A800	64 msec.
18	Increments of Transmission Cycle	4	Yes	0x00000001	Available to 31.25, 62.5, 125, 250, 500 [µsec.] & 1 – 64 [msec.] (1 msec. increments)
19	Min. Communication Cycle	4	Yes	0x000030D4	125 µsec.
1A	Max. Communication Cycle	4	Yes	0x0061A800	64 msec.
1B	Transmission Bytes	4	Yes	0x00000002	16 Bytes
1C	Transmission Bytes (Current Setting)	4	Yes	0x00000002	16 Bytes
1D	Profile Type (Current Selection)	4	Yes	0x00000001 / 0x00000030	Event-driven communication / Cyclic communication
20	Supported Communication Mode	4	Yes	0x00000003	Event-driven communication / Cyclic communication
21	MAC Address	4	No	–	
30	List of Supported Main Commands	32	Yes	0x0000C079 0x00000001 0x00000000 0x00000000 0x00000000 0x00000000 0x00000000 0x00000000 0x00000000	ALM_CLR, ALM_RD, CONFIG, ID_RD, NOP, DISCONNECT, CONNECT, DATA_RWA
38	List of Supported Sub Commands	32	No	–	
40	List of Common Parameters	32	No	–	
80	Main Device Name	32	Yes	0x34473752 0x334C4D46 0x442D362D 0x41363143 0x00000000 0x00000000 0x00000000 0x00000000	"R7G4FML3-6-DC16A"
90	Sub Device 1 Name	4	No	–	
98	Sub Device 1 Version	32	No	–	
A0	Sub Device 2 Name	4	No	–	
A8	Sub Device 2 Version	32	No	–	
B0	Sub Device 3 Name	4	No	–	
B8	Sub Device 3 Version	32	No	–	

I/O DATA DESCRIPTION

■ DISCRETE OUTPUT

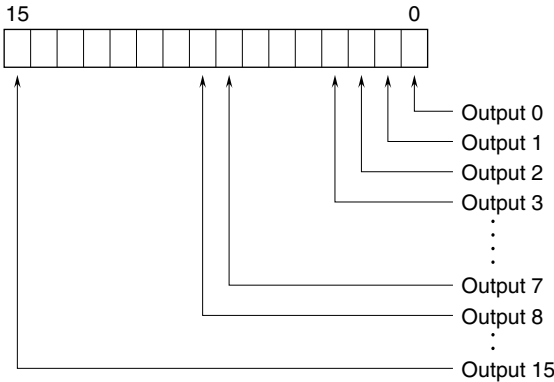

0:OFF 1:ON