

**DeviceNet® I/O MODULE**

(NPN discrete input, 16 points, tension clamp terminal block)

MODEL R7F4DD-DA16A-C

**BEFORE USE ....**

Thank you for choosing us. Before use, please check contents of the package you received as outlined below.

If you have any problems or questions with the product, please contact our sales office or representatives.

**■ PACKAGE INCLUDES:**

Discrete input module.....(1)  
DIN rail mounter slider.....(2)

**■ MODEL NO.**

Confirm Model No. marking on the product to be exactly what you ordered.

**■ INSTRUCTION MANUAL**

This manual describes necessary points of caution when you use this product, including installation, connection and basic maintenance procedures.

**■ EDS FILE**

EDS files are downloadable at our web site.

**POINTS OF CAUTION****■ CONFORMITY WITH EU DIRECTIVES**

- The equipment must be mounted inside the instrument panel of a metal enclosure.
- The actual installation environments such as panel configurations, connected devices, connected wires, may affect the protection level of this unit when it is integrated in a panel system. The user may have to review the CE requirements in regard to the whole system and employ additional protective measures\* to ensure the CE conformity.

\* For example, installation of noise filters and clamp filters for the power source, input and output connected to the unit, etc.

**■ GENERAL PRECAUTIONS**

- Before you remove the unit or mount it, turn off the power supply and input signal for safety.
- Before you remove the terminal block or mount it, make sure to turn off the power supply and input signal for safety.
- DO NOT set the switches on the module while the power is supplied. The switches are used only for maintenance without the power.

**■ ENVIRONMENT**

- Indoor use.
- When heavy dust or metal particles are present in the air, install the unit inside proper housing with sufficient ventilation.
- Do not install the unit where it is subjected to continuous vibration. Do not subject the unit to physical impact.
- Environmental temperature must be within -10 to +55°C (14 to 131°F) with relative humidity within 30 to 90% RH in order to ensure adequate life span and operation.
- Observe at the minimum of 10 mm left and right the units for heat dissipation when mounting vertically.

**■ WIRING**

- Do not install cables close to noise sources (relay drive cable, high frequency line, etc.).
- Do not bind these cables together with those in which noises are present. Do not install them in the same duct.

**■ AND ....**

- The unit is designed to function as soon as power is supplied, however, a warm up for 10 minutes is required for satisfying complete performance described in the data sheet.

# COMPONENT IDENTIFICATION

## FRONT VIEW

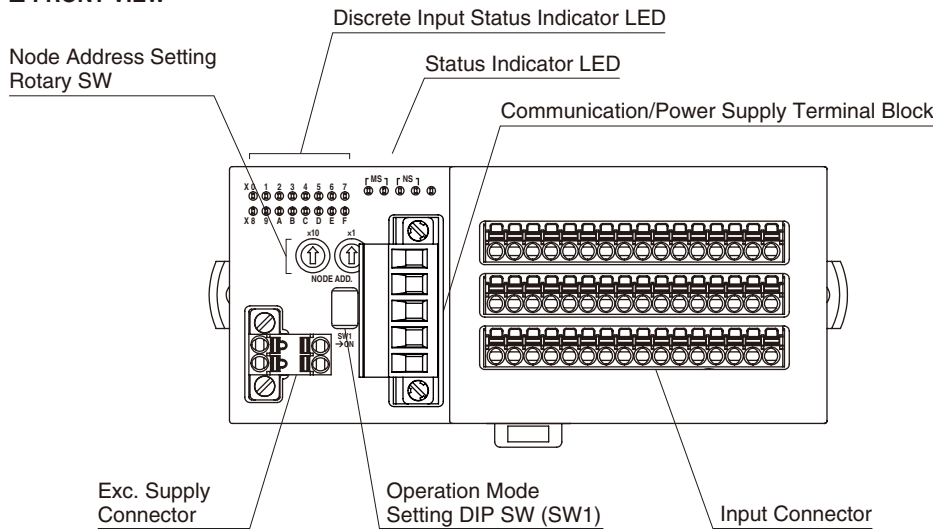

## SIDE VIEW

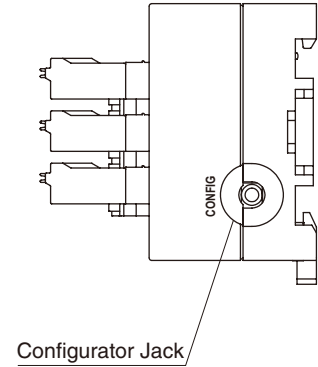

### STATUS INDICATOR LED

ID	STATUS	COLOR	FUNCTION
MS	ON	Green	Normal operation
	Blinking	Green	Not set
	ON	Red	Critical failure
	Blinking	Red	Minor failure
	OFF	-	No power supply
NS	ON	Green	Connections are established
	Blinking	Green	Connections are not established
	ON	Red	Critical Link failure
	Blinking	Red	Minor Link failure
	OFF	-	No power supply

### DISCRETE INPUT STATUS INDICATOR LED

LED green indicators shows the signal status.

- ON : LED ON
- OFF : LED OFF

### NODE ADDRESS

The left switch determines the tenth place digit, while the right switch does the ones place digit of the address. Address is selected between 0 to 63.

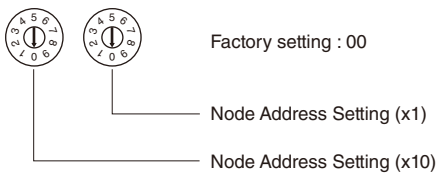

### OPERATION MODE

(\*) Factory setting

#### Baud Rate: SW1-1, 1-2

Baud Rate is selected with the DIP switch.

BAUD RATE	SW1	
	1	2
125 kbps	OFF	OFF
250 kbps	ON	OFF
500 kbps	OFF	ON
Auto-tracking (*)	ON	ON

#### Status: SW1-3

STATUS	SW1
	3
Without (*)	OFF
With	ON

Note 1: The R7F4DD communicates in the baud rate setting detected at the startup with the switch set to the positions 0 (125 kbps), 1 (250 kbps) or 2 (500 kbps).

For the settings auto-tracking, it analyzes the PLC's network to determine the baud rate on the network.

Note 2: Be sure to set unused SW1-4 to OFF.

■ TERMINAL ASSIGNMENTS

• Communication/Power Supply Terminal Assignment

Unit side connector: MSTB2,5/5-GF-5,08AU (Phoenix contact)  
 Cable side connector: MSTB2,5/5-STF-5,08AU (Phoenix contact)  
 Applicable wire size: 0.2 - 2.5mm<sup>2</sup>  
 Stripped length: 7mm

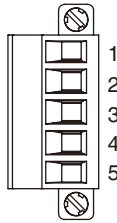

PIN NO.	COLOR	ID	FUNCTION
1	Red	V+	Communication/power supply (+)
2	White	CAN_H	Network data High
3	-	Drain	Shield
4	Blue	CAN_L	Network data Low
5	Black	V-	Communication/power supply (-)

• Exc. Supply Terminal Assignment

Unit side connector: MCV1,5/2-GF-3,5 (Phoenix contact)  
 Cable side connector: TFMC1,5/2-STF-3,5 (Phoenix contact)  
 Applicable wire size: 0.2 - 1.5mm<sup>2</sup>  
 Stripped length: 10mm  
 Recommended solderless terminal:  
 AI0,25-10YE 0.25mm<sup>2</sup> (Phoenix contact)  
 AI0,34-10TQ 0.34mm<sup>2</sup> (Phoenix contact)  
 AI0,5-10WH 0.5mm<sup>2</sup> (Phoenix contact)  
 AI0,75-10GY 0.75mm<sup>2</sup> (Phoenix contact)  
 AI1-10 1.0mm<sup>2</sup> (Phoenix contact)  
 AI1,5-10 1.5mm<sup>2</sup> (Phoenix contact)

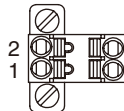

PIN NO.	ID	FUNCTION
1	SNSR.EXC+	Exc. supply +
2	SNSR.EXC-	Exc. supply -

• Input Terminal Assignment

Unit side connector: MCV1,5/16-G-3,5 (Phoenix contact)  
 Cable side connector: FMC1,5/16-ST-3,5 (Phoenix contact)  
 Applicable wire size: 0.2 - 1.5mm<sup>2</sup>  
 Stripped length: 10mm  
 Recommended Solderless Terminal:  
 AI0,25-10YE 0.25mm<sup>2</sup> (Phoenix contact)  
 AI0,34-10TQ 0.34mm<sup>2</sup> (Phoenix contact)  
 AI0,5-10WH 0.5mm<sup>2</sup> (Phoenix contact)  
 AI0,75-10GY 0.75mm<sup>2</sup> (Phoenix contact)  
 AI1-10 1.0mm<sup>2</sup> (Phoenix contact)  
 AI1,5-10 1.5mm<sup>2</sup> (Phoenix contact)

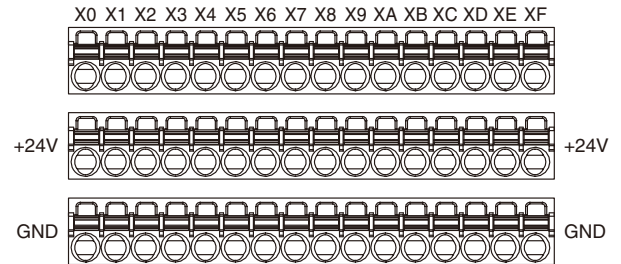

PIN NO.	ID	FUNCTION	PIN NO.	ID	FUNCTION
X0	1	X0 Input 0	X8	1	X8 Input 8
	2	+24V 24V DC		2	+24V 24V DC
	3	GND 0V		3	GND 0V
X1	1	X1 Input 1	X9	1	X9 Input 9
	2	+24V 24V DC		2	+24V 24V DC
	3	GND 0V		3	GND 0V
X2	1	X2 Input 2	XA	1	XA Input 10
	2	+24V 24V DC		2	+24V 24V DC
	3	GND 0V		3	GND 0V
X3	1	X3 Input 3	XB	1	XB Input 11
	2	+24V 24V DC		2	+24V 24V DC
	3	GND 0V		3	GND 0V
X4	1	X4 Input 4	XC	1	XC Input 12
	2	+24V 24V DC		2	+24V 24V DC
	3	GND 0V		3	GND 0V
X5	1	X5 Input 5	XD	1	XD Input 13
	2	+24V 24V DC		2	+24V 24V DC
	3	GND 0V		3	GND 0V
X6	1	X6 Input 6	XE	1	XE Input 14
	2	+24V 24V DC		2	+24V 24V DC
	3	GND 0V		3	GND 0V
X7	1	X7 Input 7	XF	1	XF Input 15
	2	+24V 24V DC		2	+24V 24V DC
	3	GND 0V		3	GND 0V

## MOUNTING INSTRUCTIONS

### ■ DIN RAIL MOUNTING (PARALLEL)

#### • Mounting

- A) Set the upper hook at the rear side of the unit on the DIN rail.
- B) Push in the lower.

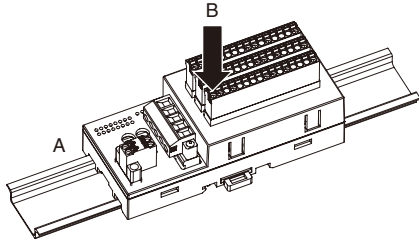

#### • Dismounting

- A) Push down the DIN rail munter slider with tip of a minus screwdriver.
- B) Pull the lower of the unit.
- C) Remove the upper hook of the unit from the DIN rail.

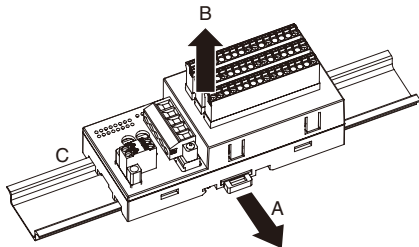

### ■ DIN RAIL MOUNTING (RIGHT ANGLE)

#### • Mounting

- A) Insert the longer DIN rail munter slider until it clicks twice, as shown below.

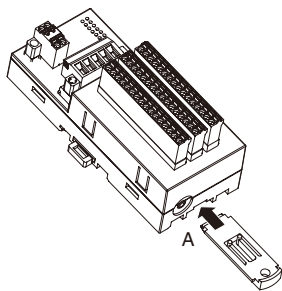

- B) Set the upper hook at the rear side of the unit on the DIN rail.
- C) Push in the lower.

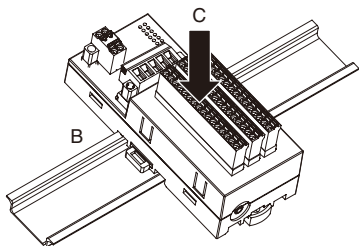

Note: leave at least 10 mm (.39 in.) at the both side of the unit.

#### • Dismounting

- A) Push down the DIN rail munter slider with tip of a minus screwdriver.
- B) Pull the lower of the unit.
- C) Remove the upper hook of the unit from the DIN rail.

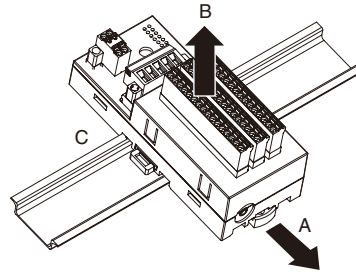

### ■ SURFACE MOUNTING

- A) Insert the two DIN rail munter sliders until it clicks once, as shown below.

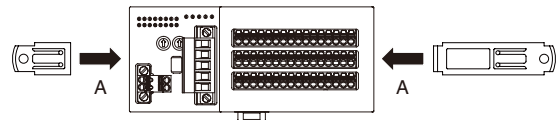

- B) Mount the unit with M4 screws referring the External Dimensions. (Torque: 1.4 N·m)

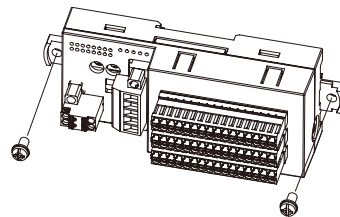

# TERMINAL CONNECTIONS

Connect the unit as in the diagram below.

## EXTERNAL DIMENSIONS unit: mm [inch]

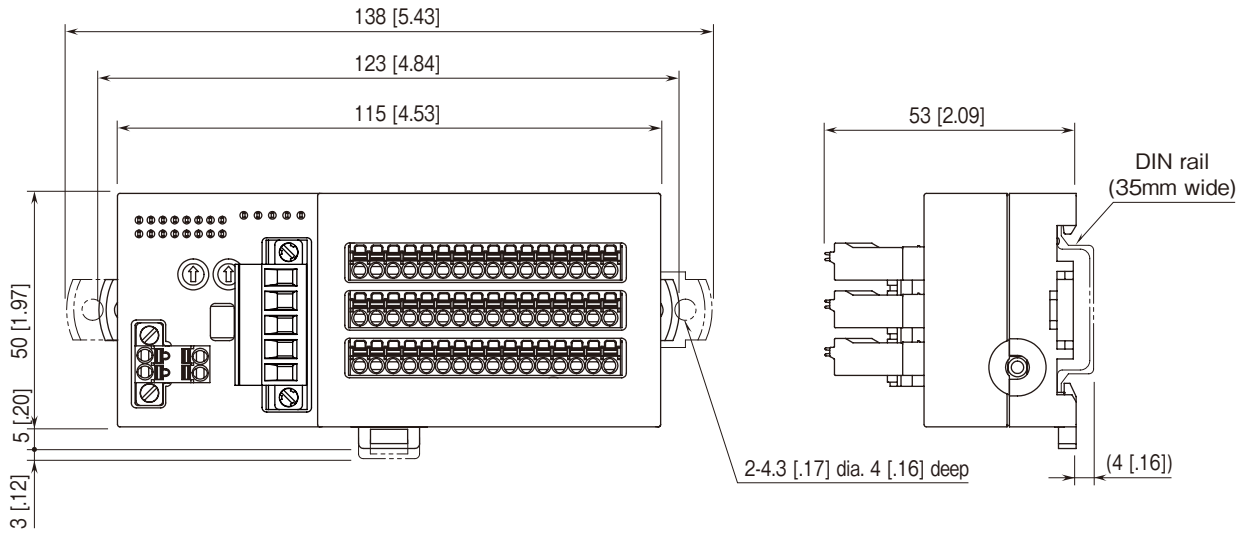

## CONNECTION DIAGRAM

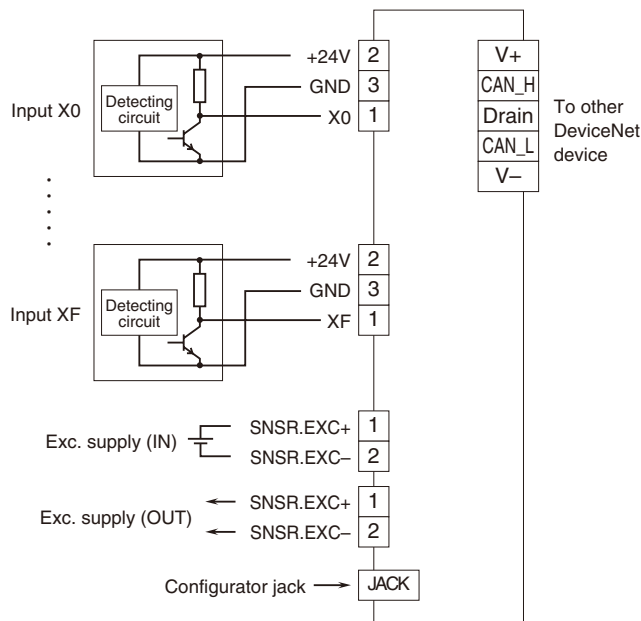

### 2-Wire Sensor

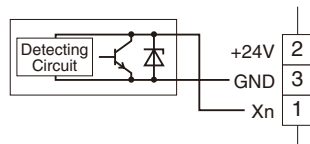

## MOUNTING REQUIREMENTS unit: mm [inch]

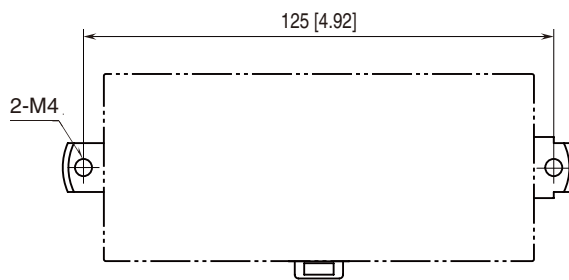

## PC CONFIGURATOR

R7F4DD can be monitored with the PC configurator software (model: R7CFG).  
Refer to the users manual for the R7CFG for detailed operation of the software program.

## DATA ALLOCATION

'Begin' address is determined by the R7F4DD's node address and the master setting.

### ■ Without status

	15	Output data	0	Input data
Begin + 0	R7F4DD-DA16A			None

### ■ With status

	15	Output data	0	Input data
Begin + 0	R7F4DD-DA16A			None
+1	Status			

## I/O DATA DESCRIPTIONS

### ■ DISCRETE INPUT

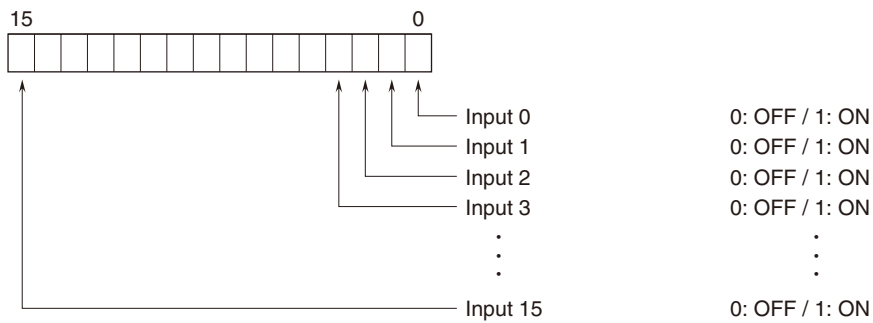

### ■ STATUS

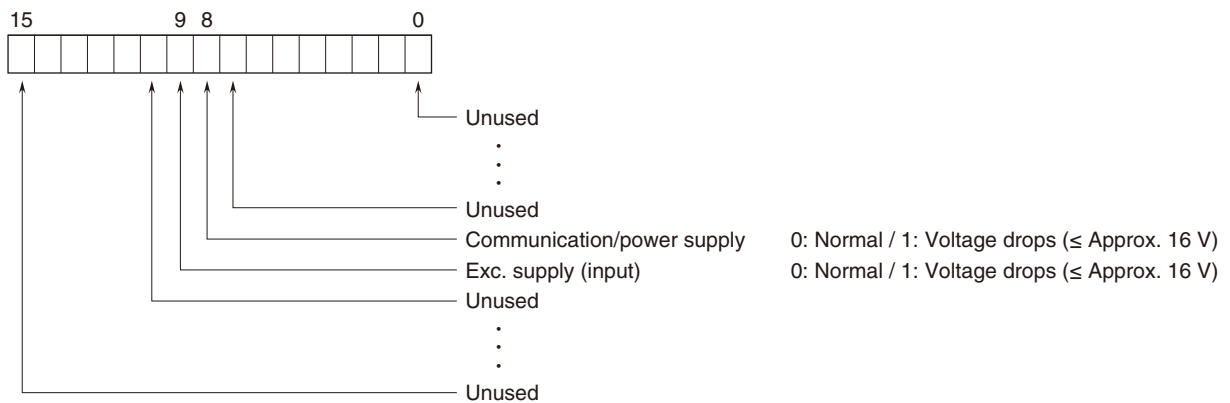

## TRANSMISSION DATA DESCRIPTIONS

### ■ I/O DATA

(Unit: word)

MODEL	OUTPUT DATA* <sup>1</sup> (R7F4DD to master)	INPUT DATA* <sup>2</sup> (master to R7F4DD)
R7F4DD-DA16A	1	0

### ■ STATUS

Status signal can be included in the transmission data when the SW1-3 is ON.

For details, refer to "STATUS in I/O DATA DESCRIPTIONS".

(Unit: word)

STATUS	OUTPUT DATA* <sup>1</sup> (R7F4DD to master)	INPUT DATA* <sup>2</sup> (master to R7F4DD)
With	1	0
Without	0	0

\*1. Output Data means those sent to the master.

\*2. Input Data means those received from the master.