

Remote I/O R5 Series

AC CURRENT INPUT MODULE

(clamp-on current sensor type CLSA use;
screw terminal block; true RMS sensing)

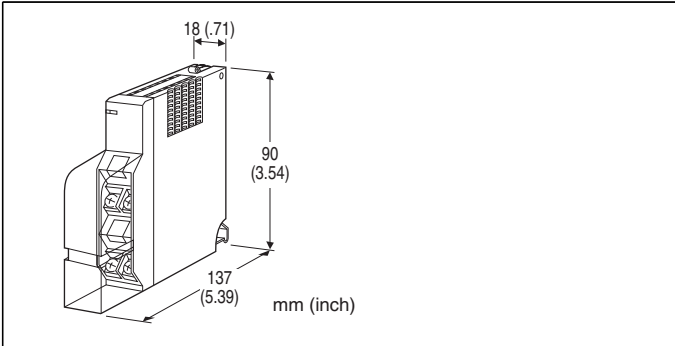

MODEL: R5T-CTA[1][2][3]

ORDERING INFORMATION

Code number: R5T-CTA[1][2][3]

Specify a code from below for each [1] through [3].

(e.g. R5T-CTA2W/Q)

- Specify the specification for option code /Q (e.g. /C01/S01)

[1] NO. OF CHANNELS

- 1: 1 channel
- 2: 2 channels

[2] COMMUNICATION MODE

- S: Single
- W: Dual

[3] OPTIONS

blank: none

/Q: With options (specify the specification)

SPECIFICATIONS OF OPTION: Q (multiple selections)

COATING (For the detail, refer to M-System's web site.)

- /C01: Silicone coating
- /C02: Polyurethane coating
- /C03: Rubber coating

TERMINAL SCREW MATERIAL

- /S01: Stainless steel

RELATED PRODUCTS

- Clamp-on current sensor (model: CLSA-08)
- Clamp-on current sensor (model: CLSA-12)

- Clamp-on current sensor (model: CLSA-30)
- Clamp-on current sensor (model: CLSA-50)
- Special cable (model: CLSA-08C)

The clamp-on current sensor, not included in the product package, must be ordered separately.

Refer to the data sheet for the sensor for more information such as applicable wire diameter.

GENERAL SPECIFICATIONS

Connection

Internal bus: Via the Installation Base (model: R5-BS)

Input: M3.5 screw terminal block (torque 0.8 N·m)

Internal power: Via the base (model: R5-BS)

Screw terminal: Nickel-plated steel (standard) or stainless steel

Isolation: Input 1 to input 2 to internal bus or internal power

Input waveform

RMS sensing: Up to 15 % of 3rd harmonic content

Input range: Selectable with the side DIP SW

RUN indicator: Bi-color (red/green) LED;

Red when the bus A operates normally;

Green when the bus B operates normally;

Amber when both buses operate normally.

Low-end cutout: Converted as 0 % for the input below 2 %

INPUT SPECIFICATIONS

Frequency: 50 or 60 Hz

Operational range: 5 - 115 % of rating

Max. working voltage: 440 V AC (primary side)

Sensor & range:

CLSA-08: 0 - 80 A AC

CLSA-12: 0 - 120 A AC

CLSA-30: 0 - 300 A AC

CLSA-50: 0 - 500 A AC

INSTALLATION

Operating temperature: -10 to +55°C (14 to 131°F)

Operating humidity: 30 to 90 %RH (non-condensing)

Atmosphere: No corrosive gas or heavy dust

Mounting: Installation Base (model: R5-BS)

Weight: 110 g (0.24 lb)

PERFORMANCE

Conversion accuracy: $\pm 0.5\%$ (at 5 - 100 % input) except the sensor accuracy

Data range: Engineering unit value $\times 100$ (binary without sign)

Data allocation: 1 (2 for 2-channel type)

Temp. coefficient: $\pm 0.015\%/^{\circ}\text{C}$ ($\pm 0.008\%/^{\circ}\text{F}$)

Response time: ≤ 0.5 sec. (0 - 90 %)

Insulation resistance: $\geq 100\ \text{M}\Omega$ with 500 V DC

Dielectric strength: 1500 V AC @ 1 minute (input 1 to input 2 to internal bus or internal power)

2000 V AC @ 1 minute (power input to FG; isolated on the power supply module)

EXTERNAL VIEW

■ SIDE VIEW

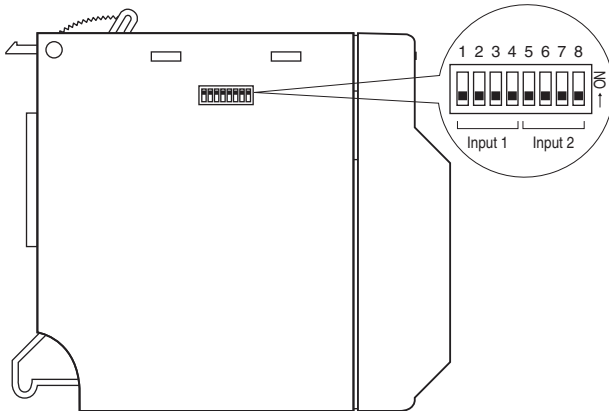

■ FRONT VIEW

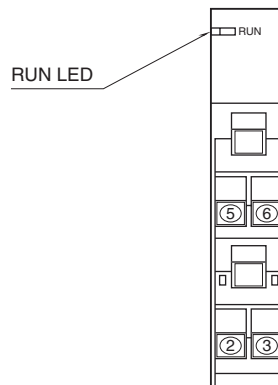

INPUT DATA DESCRIPTIONS

■ ANALOG DATA (AC CURRENT DATA.)

16-bit binary data.

Integer obtained by multiplying unit value (A) by 100.



EXTERNAL DIMENSIONS & TERMINAL ASSIGNMENTS unit: mm (inch)

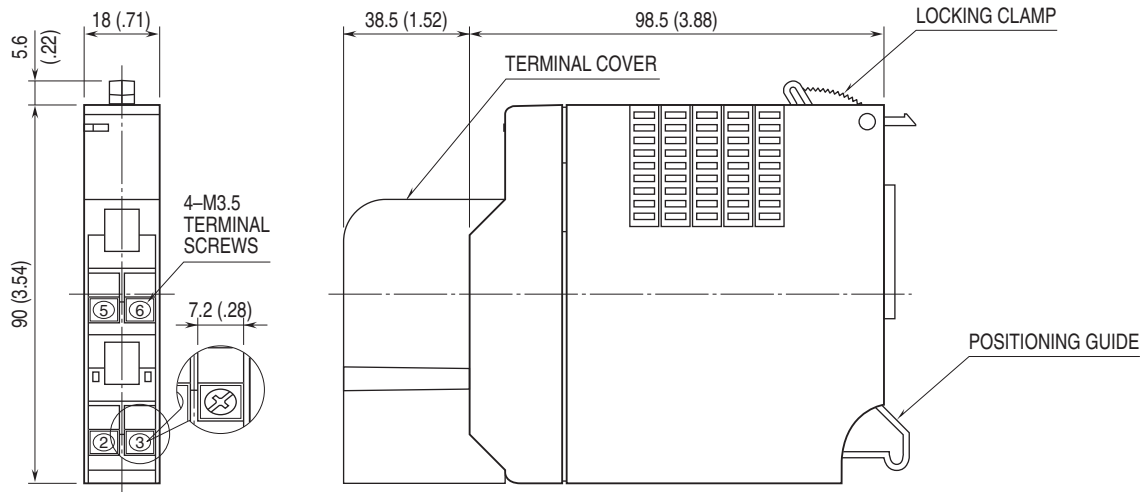

SCHEMATIC CIRCUITRY & CONNECTION DIAGRAM

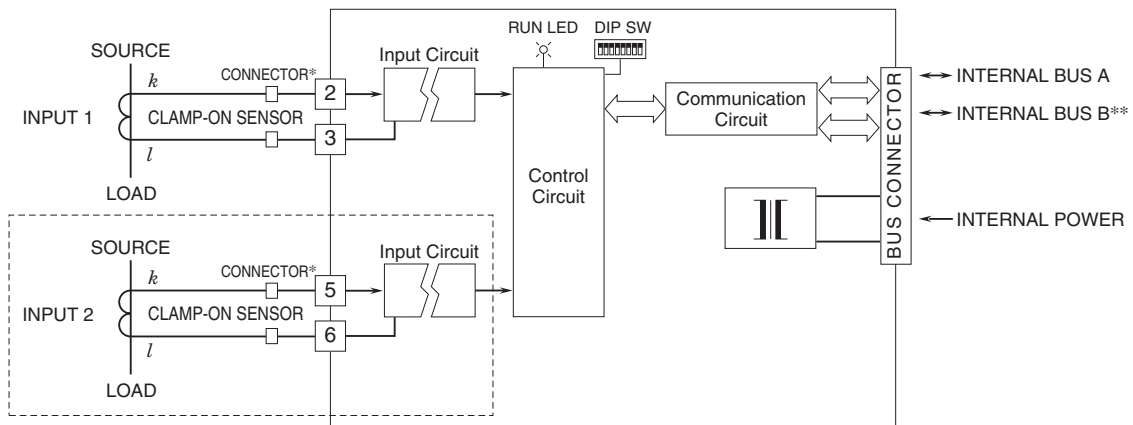

* Connector provided only for the CLSA-08 and CLSA-12.
 **For dual redundant communication.
 Note: The section enclosed by broken line is with 2-ch. option.



Specifications are subject to change without notice.