

<b>RTD INPUT MODULE</b> (screw terminal block)	MODEL <b>R5T-RS</b>
---	---------------------

**BEFORE USE ....**

Thank you for choosing M-System. Before use, please check contents of the package you received as outlined below. If you have any problems or questions with the product, please contact M-System's Sales Office or representatives.

**■ PACKAGE INCLUDES:**

RTD input module.....(1)

**■ MODEL NO.**

Confirm Model No. marking on the product to be exactly what you ordered.

**■ INSTRUCTION MANUAL**

This manual describes necessary points of caution when you use this product, including installation, connection and basic maintenance procedures.

**POINTS OF CAUTION**

**■ CONFORMITY WITH EU DIRECTIVES**

- The equipment must be mounted inside the instrument panel of a metal enclosure.
- The actual installation environments such as panel configurations, connected devices, connected wires, may affect the protection level of this unit when it is integrated in a panel system. The user may have to review the CE requirements in regard to the whole system and employ additional protective measures to ensure the CE conformity.

**■ HOT INSERTION/REMOVAL OF MODULES**

- Removing or replacing modules does not affect other modules on the same backplane. It is possible to replace them without removing the power supply. However, replacing multiple modules at once may greatly change line voltage levels. We recommend that you replace them one by one.

**■ GENERAL PRECAUTIONS**

- DO NOT set the switches while the power is supplied. The switches are used only for maintenance without the power.

**■ ENVIRONMENT**

- Indoor use.
- When heavy dust or metal particles are present in the air, install the unit inside proper housing with sufficient ventilation.
- Do not install the unit where it is subjected to continuous vibration. Do not subject the unit to physical impact.
- Environmental temperature must be within -10 to +55°C (14 to 131°F) with relative humidity within 30 to 90% RH in order to ensure adequate life span and operation.

**■ WIRING**

- Do not install cables close to noise sources (relay drive cable, high frequency line, etc.).
- Do not bind these cables together with those in which noises are present. Do not install them in the same duct.

**■ AND ....**

- The unit is designed to function as soon as power is supplied, however, a warm up for 10 minutes is required for satisfying complete performance described in the data sheet.

**INSTALLATION**

Use the Installation Base (model: R5-BS).

## COMPONENT IDENTIFICATION

### ■ SIDE VIEW

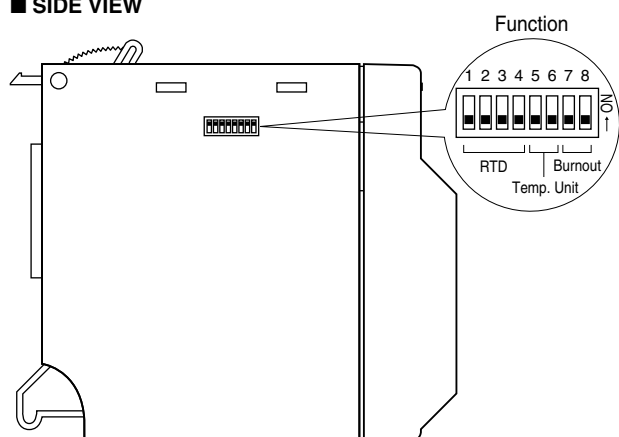

### ■ FRONT VIEW

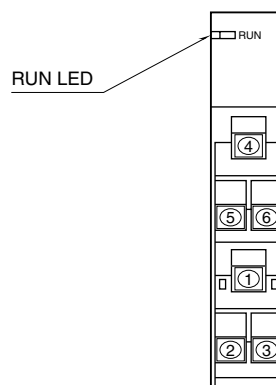

### ■ STATUS INDICATOR LED

**RUN indicator:** Bi-color (red/green) LED;  
 Red when the bus A operates normally;  
 Green when the bus B operates normally;  
 Amber when both buses operate normally.

### ■ SIDE DIP SW

(\*) Factory setting

#### • RTD Type: SW1, 2, 3, 4

SW				RTD
1	2	3	4	
ON	OFF	ON	OFF	Cu 10 @ 25°C
OFF	OFF	OFF	OFF	Cu 50
OFF	OFF	OFF	ON	JPt 100 (JIS '89)
ON	OFF	OFF	OFF	Pt 100 (JIS '89)
OFF	ON	OFF	OFF	Pt 100 (JIS '97, IEC) (*)
OFF	ON	ON	OFF	Pt 1000
ON	ON	OFF	OFF	Pt 50 Ω (JIS '81)
OFF	OFF	ON	OFF	Ni 100
ON	ON	ON	OFF	Ni 508.4 Ω

#### • Temperature Unit: SW5, 6

SW		TEMP. UNIT
5	6	
OFF	OFF	°C (*)
ON	OFF	°F
OFF	ON	K (Absolute Temp)

#### • Burnout: SW7, 8

SW		BURNOUT
7	8	
INPUT 1	INPUT 2	
OFF	OFF	Downscale
ON	ON	Upscale (*)

## PC CONFIGURATOR

With configurator software, settings shown below are available.  
 Refer to the software manual of R5CON for detailed operation.

### ■ CHANNEL INDIVIDUAL SETTING

PARAMETER	AVAILABLE RANGE	DEFAULT SETTING
Zero Scale	-32000 to +32000	0
Full Scale	-32000 to +32000	10000
Bias [Zero Adj.]	-320.00 to +320.00	0.00
Gain [Span Adj.]	-32000 to +32000	1.0000
Zero Base	Depends on sensor type	0.00
Full Base	Depends on sensor type	0.00

### ■ CHANNEL BATCH SETTING

PARAMETER	AVAILABLE RANGE	DEFAULT SETTING
Limit	No check mark: Limits to the scaling values equivalent to -15 % to +115 %. Check-marked: Limits within Zero Scale to Full Scale.	No check mark

## TERMINAL CONNECTIONS

Connect the unit as in the diagram below.

### EXTERNAL DIMENSIONS unit: mm (inch)

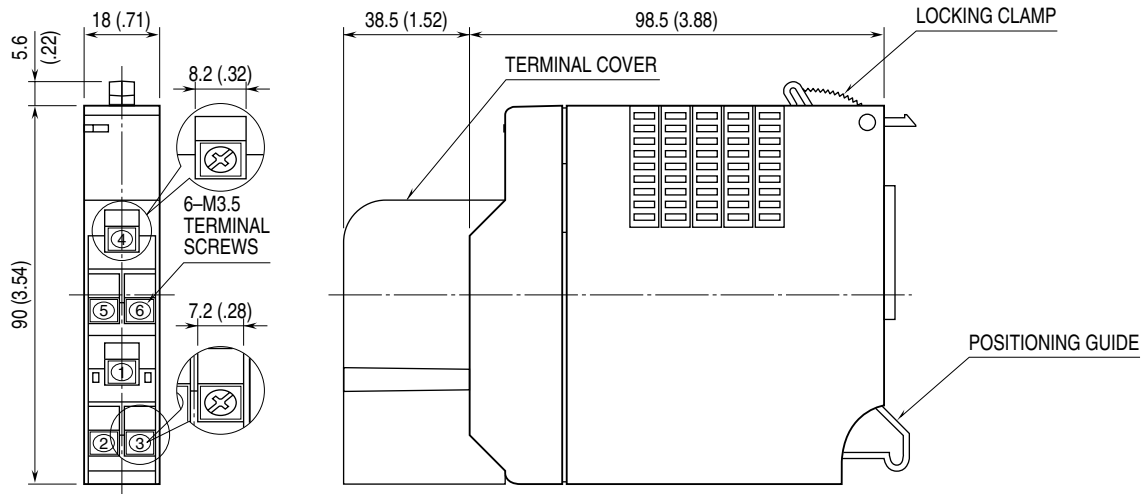

### CONNECTION DIAGRAM

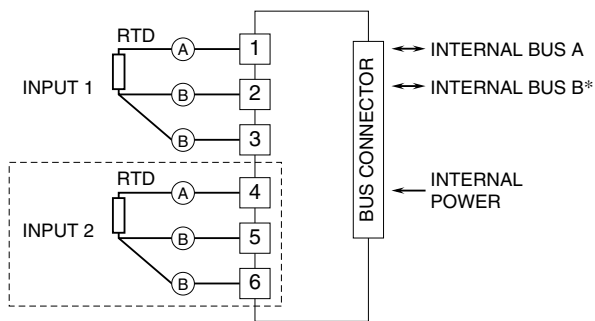

\*For dual redundant communication.

Note: The section enclosed by broken line is with 2-ch. option.

## WIRING INSTRUCTIONS

### SCREW TERMINAL

Torque: 0.8 N·m