

AC CURRENT INPUT MODULE

(clamp-on current sensor type CLSA use; screw terminal block; true RMS sensing)

MODEL

R5T-CTA**BEFORE USE**

Thank you for choosing M-System. Before use, please check contents of the package you received as outlined below.

If you have any problems or questions with the product, please contact M-System's Sales Office or representatives.

■ PACKAGE INCLUDES:

AC current input module.....(1)

■ MODEL NO.

Confirm Model No. marking on the product to be exactly what you ordered.

■ INSTRUCTION MANUAL

This manual describes necessary points of caution when you use this product, including installation, connection and basic maintenance procedures.

POINTS OF CAUTION**■ HOT INSERTION/REMOVAL OF MODULES**

- Removing or replacing modules does not affect other modules on the same backplane. It is possible to replace them without removing the power supply. However, replacing multiple modules at once may greatly change line voltage levels. We recommend that you replace them one by one.

■ GENERAL PRECAUTIONS

- DO NOT set the switches while the power is supplied. The switches are used only for maintenance without the power.

■ ENVIRONMENT

- Indoor use.
- When heavy dust or metal particles are present in the air, install the unit inside proper housing with sufficient ventilation.
- Do not install the unit where it is subjected to continuous vibration. Do not subject the unit to physical impact.
- Environmental temperature must be within -10 to +55°C (14 to 131°F) with relative humidity within 30 to 90% RH in order to ensure adequate life span and operation.

■ WIRING

- Do not install cables close to noise sources (relay drive cable, high frequency line, etc.).
- Do not bind these cables together with those in which noises are present. Do not install them in the same duct.

■ AND

- The unit is designed to function as soon as power is supplied, however, a warm up for 10 minutes is required for satisfying complete performance described in the data sheet.

INSTALLATION

Use the Installation Base (model: R5-BS).

COMPONENT IDENTIFICATION

■ SIDE VIEW

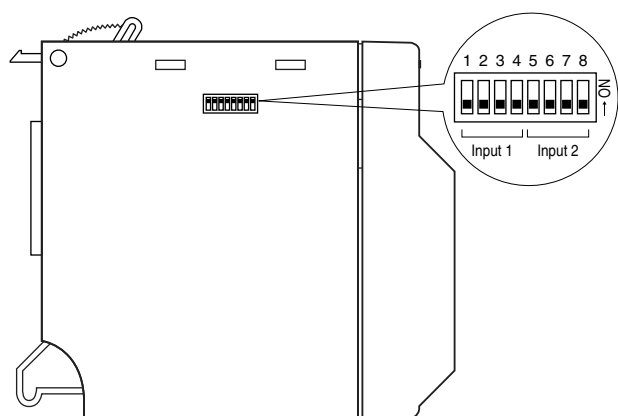

■ FRONT VIEW

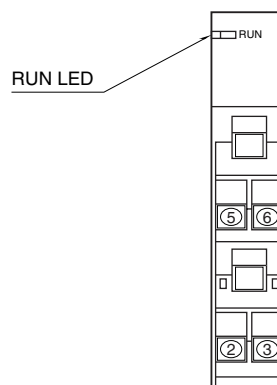

■ STATUS INDICATOR LED

RUN indicator: Bi-color (red/green) LED;

Red when the bus A operates normally;

Green when the bus B operates normally;

Amber when both buses operate normally.

■ SIDE DIP SW

- Input Range: SW1 through 8

Each channel independent

SW								RANGE
INPUT 1				INPUT 2				
1	2	3	4	5	6	7	8	
OFF	OFF	OFF	OFF	OFF	OFF	OFF	OFF	CLSA-50 (*)
ON	OFF	OFF	OFF	ON	OFF	OFF	OFF	CLSA-30
OFF	ON	OFF	OFF	OFF	ON	OFF	OFF	CLSA-12
ON	ON	OFF	OFF	ON	ON	OFF	OFF	CLSA-08

(*) Factory setting

PC CONFIGURATOR

With configurator software, settings shown below are available.

Refer to the software manual of R5CON for detailed operation.

■ CHANNEL INDIVIDUAL SETTING

PARAMETER	AVAILABLE RANGE	DEFAULT SETTING
Zero Scale	-32000 to +32000	0
Full Scale	-32000 to +32000	10000
Bias [Zero Adj.]	-320.00 to +320.00	0.00
Gain [Span Adj.]	-32000 to +32000	1.0000
Zero Base	Depends on sensor type	
Full Base	Depends on sensor type	

INPUT DATA DESCRIPTIONS

■ ANALOG DATA (AC CURRENT DATA)

16-bit binary data.

Integer that engineering unit value (A) multiplied by 100.



TERMINAL CONNECTIONS

Connect the unit as in the diagram below.

EXTERNAL DIMENSIONS unit: mm (inch)

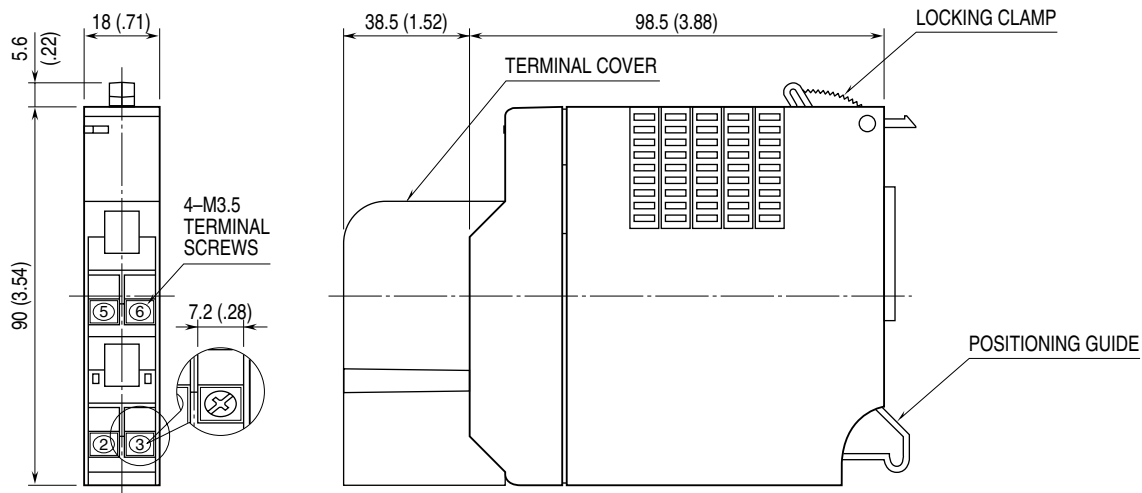

CONNECTION DIAGRAM

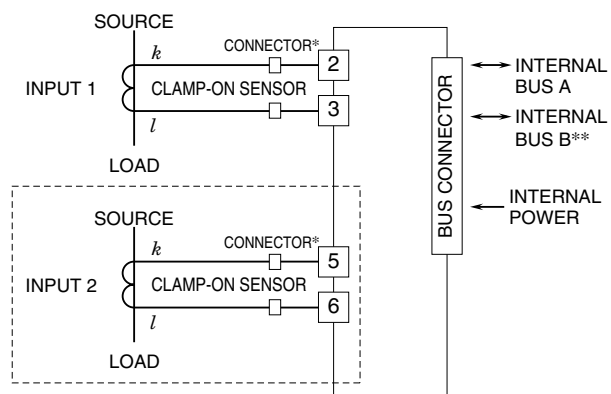

* Connector provided only for the CLSA-08 and CLSA-12.

**For dual redundant communication.

Note: The section enclosed by broken line is with 2-ch. option.

WIRING INSTRUCTIONS

SCREW TERMINAL

Torque: 0.8 N·m