

**ETHERNET INTERFACE MODULE
(Modbus/TCP)**

MODEL **R5-NE1**

BEFORE USE

Thank you for choosing M-System. Before use, please check contents of the package you received as outlined below. If you have any problems or questions with the product, please contact M-System's Sales Office or representatives.

■ PACKAGE INCLUDES:

Network interface module(1)

■ MODEL NO.

Confirm Model No. marking on the product to be exactly what you ordered.

■ INSTRUCTION MANUAL

This manual describes necessary points of caution when you use this product, including installation, connection and basic maintenance procedures.

POINTS OF CAUTION

■ CONFORMITY WITH EU DIRECTIVES

- Use with Ver.2.00 or higher versions of Power Supply Module (model: R5-PS).
- The equipment must be mounted inside the instrument panel of a metal enclosure.
- The actual installation environments such as panel configurations, connected devices, connected wires, may affect the protection level of this unit when it is integrated in a panel system. The user may have to review the CE requirements in regard to the whole system and employ additional protective measures to ensure the CE conformity.

■ HOT-SWAPPABLE MODULES

- The module can be replaced while the power is ON. Be sure to replace it when the module is not communicating with a host, as it may affect the system. Replacing multiple modules at once may greatly change line voltage levels. We highly recommend to replace them one by one.

■ GENERAL PRECAUTIONS

- Do not set the DIP switch on the side panel while the power is supplied. The DIP switch is selectable for maintenance without the power.

■ ENVIRONMENT

- Indoor use.
- When heavy dust or metal particles are present in the air, install the unit inside proper housing with sufficient ventilation.
- Do not install the unit where it is subjected to continuous vibration. Do not subject the unit to physical impact.
- Environmental temperature must be within -10 to +55°C (14 to 131°F) with relative humidity within 30 to 90% RH in order to ensure adequate life span and operation.

■ WIRING

- Do not install cables close to noise sources (relay drive cable, high frequency line, etc.).
- Do not bind these cables together with those in which noises are present. Do not install them in the same duct.

■ AND

- The unit is designed to function as soon as power is supplied, however, a warm up for 10 minutes is required for satisfying complete performance described in the data sheet.

INSTALLATION

Use the Installation Base (model: R5-BS).

Before mounting the Network Interface Module onto the Base, be sure to configure the module as explained below.

■ DATA ALLOCATION MODE

The setting determines the data area size assigned to each I/O module mounted on the base.

The data sent/received via Modbus/TCP (Ethernet) is mapped according to this setting.

When one or more of the analog I/O modules are 2-channel types, select the Mode 2. (The 2nd channel cannot be sent/received in the Mode 1.)

See "DATA ALLOCATION MODE."

■ NETWORK SLOTS ON THE BASE

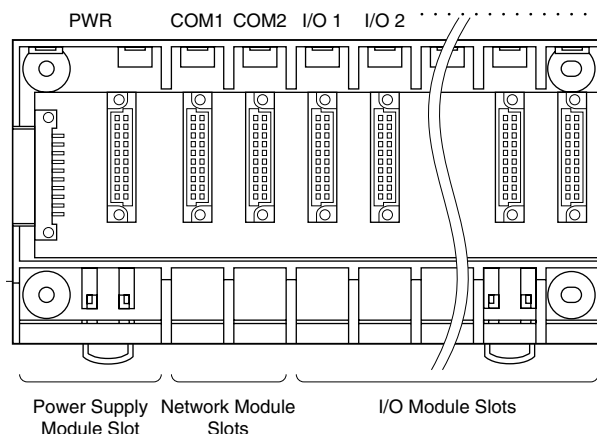

The Network Interface Modules must be mounted on the COM1 on the Base.

The COM2 is used only when the dual redundant communication is selected. If the I/O modules are selected for the dual communication, the Network Module can be mounted either on the COM1 or COM2.

The bases for single communication mode (model: R5-BS05, R5-BS09) does not have COM2.

COMPONENT IDENTIFICATION

■ SIDE VIEW

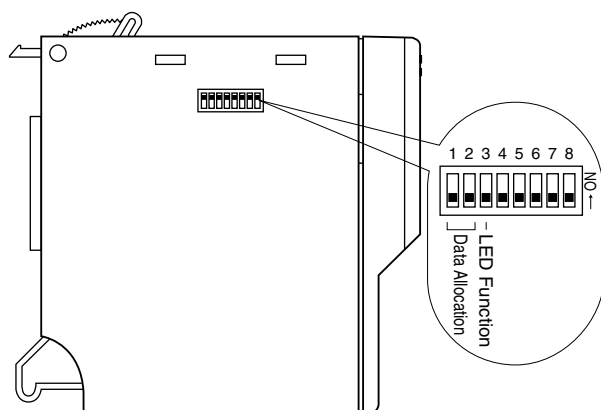

■ SIDE DIP SW

(*) Factory setting

• Data Allocation Mode: SW1, SW2

SW	DATA ALLOCATION MODE	
	2	1
1	OFF (*)	ON
2	OFF (*)	OFF

• LED Function: SW3

SW3	LED FUNCTION	
	RUN	ERR
OFF (*)	Green when normal	Green ON/blinks in an abnormality
ON	Red when receiving	Red when transmitting

Note: Be sure to set unused SW4 through 8 to OFF.

■ FRONT VIEW

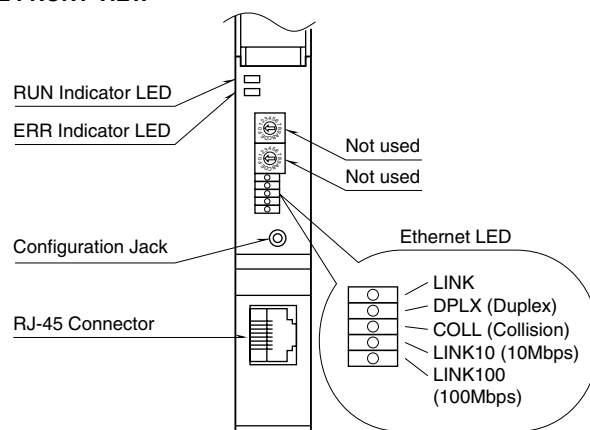

■ ETHERNET INDICATORS

ID	COLOR	FUNCTION
LINK	Red	ON at LINK
DPLX	Red	ON with full-duplex communication
LINK10	Red	ON with 10 Mbps connection
LINK100	Red	ON with 100 Mbps connection
COL	Red	Blinking when collision occurs

PC CONFIGURATOR

With configurator software, settings shown below are available.

Refer to the software manual of R5CON for detailed operation.

■ NETWORK MODULE SETTING

PARAMETER	AVAILABLE RANGE	DEFAULT SETTING
Communication Timeout	0.0 – 3276.7 (sec.)	3.0 (sec.)
IP Address	0 – 255	192.168.0.1
Subnet Mask	0 – 255	255.255.255.0
TCP Socket Port 1	0 – 32767	502
TCP Socket Port 2	0 – 32767	502
TCP Socket Port 3	0 – 32767	502
TCP Socket Port 4	0 – 32767	502
Linger 1	0.0 – 3276.7 (sec.)	180.0 (sec.)
Linger 2	0.0 – 3276.7 (sec.)	180.0 (sec.)
Linger 3	0.0 – 3276.7 (sec.)	180.0 (sec.)
Linger 4	0.0 – 3276.7 (sec.)	180.0 (sec.)

TERMINAL CONNECTIONS

Connect the unit as in the diagram below.

EXTERNAL DIMENSIONS unit: mm (inch)

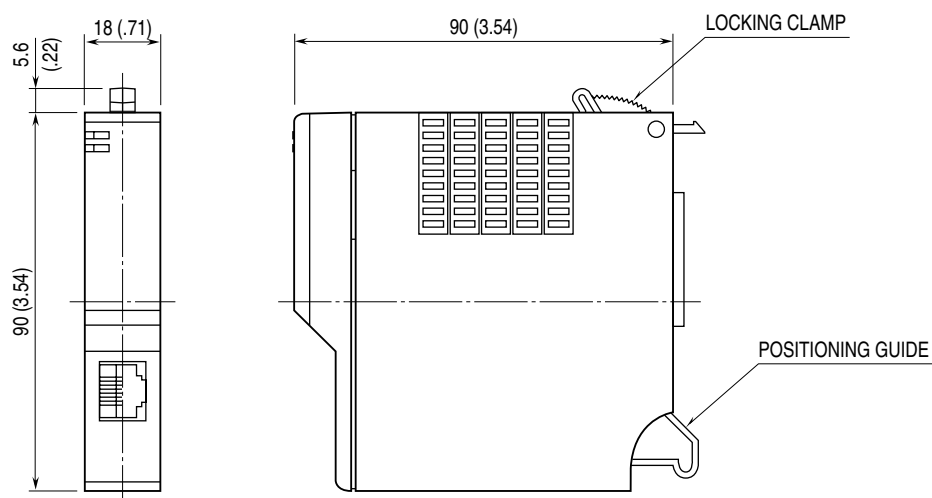

CONNECTION DIAGRAM

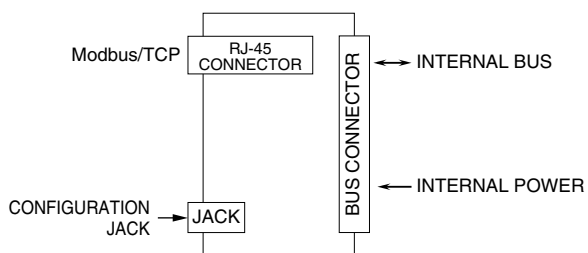

CHECKING ETHERNET CONNECTION

■ IP ADDRESS

The R5-NE1 does not support BootP Table Software. The IP Address and Subnet Mask can be configured using the R5CON Configurator Software.

The Modbus/TCP Port No. is fixed to 502.

■ DATA ALLOCATION MODE

The Data Allocation Mode is usually set to “2” with the side DIP switches. Setting “1” is used only when all the I/O modules on the base are for Data Allocation Mode 1. This setting affects analog I/O data allocations.

■ CHECK WIRING

Connect an Ethernet cable to the front RJ-45 connector.

■ CHECK LED

When wiring is correct, LINK and LINK10, or LINK and LINK100 are turned on.

When the module is receiving or sending data, LINK10 or LINK100 blinks.*

* LEDs are turned ON for firmware version V1.00 or later.

■ CHECK R5-NE1 CONNECTION

Enter “ping command” on the Windows MS-DOS as follows:

```
C:\WINDOWS>ping *.*.*.*.*
(*.*.*.*.*: Enter IP address in decimal.)

ping *.*.*.*.* with 32 bytes of data:
Reply from *.*.*.*.* : bytes=32 time<10ms TTL=64
Reply from *.*.*.*.* : bytes=32 time<10ms TTL=64
Reply from *.*.*.*.* : bytes=32 time<10ms TTL=64
Reply from *.*.*.*.* : bytes=32 time<10ms TTL=64

Ping statistics for *.*.*.*.*
Packets:Sent=4,Received=4,Lost=0(0% loss)
```

Replies in case of normal connection are as shown above. If the connection cannot be established normally due to e.g. wrong IP address, other replies such as “time over” will be received.

■ CHECK CONNECTION TO THE APPLICATION SOFTWARE

Check Point 1: LINK LEDs

When a normal connection is established, the front LINK and LINK10 or LINK100 are turned on regardless of data sending/receiving status. Check power supply to the hub in case that these LEDs are not on.

Check Point 2: RUN Indicator LED

With the side DIP SW3 is set to OFF, the RUN Indicator LED turns to Green in normal data sending/receiving.

Check Point 3: Sending/Receiving Indicators

With the side DIP SW3 is set to ON, the RUN Indicator LED turns to Red in data receiving, and the ERR Indicator LED turns to Red in data sending. In normal operating conditions, these LEDs may seem to blink at once due to the high speed transmission.

MODBUS FUNCTION CODES & SUPPORTED CODES

■ Data and Control Functions

CODE	NAME		
01	Read Coil Status	X	Digital output from the slave
02	Read Input Status	X	Status of digital inputs to the slave
03	Read Holding Registers	X	General purpose register within the slave
04	Read Input Registers	X	Collected data from the field by the slave
05	Force Single Coil	X	Digital output from the slave
06	Preset Single Register	X	General purpose register within the slave
07	Read Exception Status		
08	Diagnostics	X	
09	Program 484		
10	Poll 484		
11	Fetch Comm. Event Counter		Fetch a status word and an event counter
12	Fetch Comm. Event Log		A status word, an event counter, a message count and a field of event bytes
13	Program Controller		
14	Poll Controller		
15	Force Multiple Coils	X	Digital output from the slave
16	Preset Multiple Registers	X	General purpose register within the slave
17	Report Slave ID		Slave type / 'RUN' status
18	Program 884/M84		
19	Reset Comm. Link		
20	Read General Reference		
21	Write General Reference		
22	Mask Write 4X Register		
23	Read/Write 4X Register		
24	Read FIFO Queue		

■ Exception Codes

CODE	NAME		
01	Illegal Function	X	Function code is not allowable for the slave
02	Illegal Data Address	X	Address is not available within the slave
03	Illegal Data Value	X	Data is not valid for the function
04	Slave Device Failure		
05	Acknowledge		
06	Slave Device Busy		
07	Negative Acknowledge		
08	Memory Parity Error		

■ Diagnostic Subfunctions

CODE	NAME		
00	Return Query Data	X	Loop back test
01	Restart Comm. Option	X	Reset the slave and clear all counters
02	Return Diagnostic Register	X	Contents of the diagnostic data (2 bytes)
03	Change ASCII Input Delimiter	X	Delimiter character of ASCII message
04	Force Listen Only Mode	X	Force the slave into Listen Only Mode

DATA ALLOCATION MODE

The DIP SW located at the side of the module switches the unit's data allocation mode.

The Data Allocation Mode 1 is used when all analog I/O modules are single-channel types. In this mode, one (1) word is assigned for one I/O module. The second channel on the dual-channel modules cannot be used.

The Data Allocation Mode 2 is used when one or more analog I/O modules are dual-channel types. In this mode, two (2) words are assigned for one I/O module regardless of whether the second word area is required or not.

For discrete I/O, 16-channel area is automatically assigned to each module. For example, with a 4-channel module, the bits assigned to ch. 5 through 16 remain "0."

MODBUS I/O ASSIGNMENTS

Coil (0X)	1 – 16	Module 1	Do 1 – 16
	17 – 32	Module 2	Do 1 – 16
	33 – 48	Module 3	Do 1 – 16
	49 – 64	Module 4	Do 1 – 16
	:	:	:
	241 – 256	Module 16	Do 1 – 16
Inputs (1X)	1 – 16	Module 1	Di 1 – 16
	17 – 32	Module 2	Di 1 – 16
	33 – 48	Module 3	Di 1 – 16
	49 – 64	Module 4	Di 1 – 16
	:	:	:
	241 – 256	Module 16	Di 1 – 16
	257 – 272	Active Module Map	
273 – 288	Status		
	289 – 320	Channel Status	

■ Data Allocation Mode 1

Input Registers (3X)	1	Module 1	Ai 1 (INT)
	2	Module 2	Ai 1 (INT)
	3	Module 3	Ai 1 (INT)
	4	Module 4	Ai 1 (INT)
	:	:	:
	16	Module 16	Ai 1 (INT)
	17, 18	Module 1	Ai 1 (Float)
	19, 20	Module 2	Ai 1 (Float)
	21, 22	Module 3	Ai 1 (Float)
	23, 24	Module 4	Ai 1 (Float)
	:	:	:
	47, 48	Module 16	Ai 1 (Float)
Holding Registers (4X)	1	Module 1	Ao 1 (INT)
	2	Module 2	Ao 1 (INT)
	3	Module 3	Ao 1 (INT)
	4	Module 4	Ao 1 (INT)
	:	:	:
	16	Module 16	Ao 1 (INT)
	17, 18	Module 1	Ao 1 (Float)
	19, 20	Module 2	Ao 1 (Float)
	21, 22	Module 3	Ao 1 (Float)
	23, 24	Module 4	Ao 1 (Float)
	:	:	:
	47, 48	Module 16	Ao 1 (Float)

■ Data Allocation Mode 2

Input Registers (3X)	1	Module 1	Ai 1 (INT)
	2	Module 1	Ai 2 (INT)
	3	Module 2	Ai 1 (INT)
	4	Module 2	Ai 2 (INT)
	:	:	:
	31	Module 16	Ai 1 (INT)
	32	Module 16	Ai 2 (INT)
	33, 34	Module 1	Ai 1 (Float)
	35, 36	Module 1	Ai 2 (Float)
	37, 38	Module 2	Ai 1 (Float)
	39, 40	Module 2	Ai 2 (Float)
	:	:	:
	93, 94	Module 16	Ai 1 (Float)
	95, 96	Module 16	Ai 2 (Float)
Holding Registers (4X)	1	Module 1	Ao 1 (INT)
	2	Module 1	Ao 2 (INT)
	3	Module 2	Ao 1 (INT)
	4	Module 2	Ao 2 (INT)
	:	:	:
	31	Module 16	Ao 1 (INT)
	32	Module 16	Ao 2 (INT)
	33, 34	Module 1	Ao 1 (Float)
	35, 36	Module 1	Ao 2 (Float)
	37, 38	Module 2	Ao 1 (Float)
	39, 40	Module 2	Ao 2 (Float)
	:	:	:
	93, 94	Module 16	Ao 1 (Float)
	95, 96	Module 16	Ao 2 (Float)

Note: DO NOT access addresses other than mentioned above. Such access may cause problems such as inadequate operation.

■ ACTIVE MODULE MAP

Indicates the slots where I/O modules are mounted. When the module is mounted, the corresponding bit turns to "1."

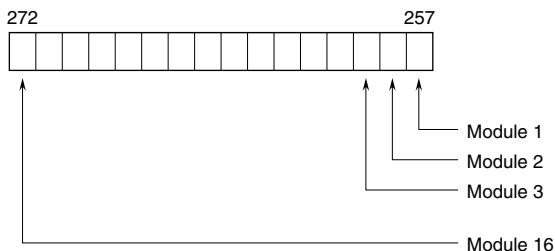

■ STATUS

Communication status data. When the module is unmounted, the module type is not correct, or when communication errors occur frequently, the corresponding bit turns to "1."

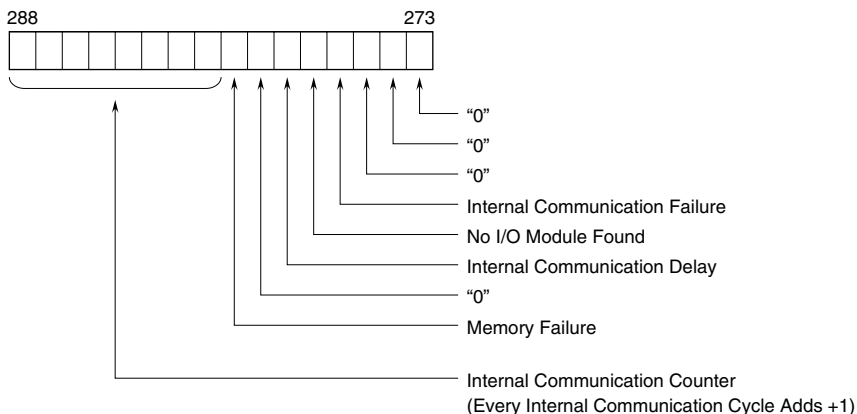

■ CHANNEL STATUS

Analog input modules check high/low limits and ADC. When there is an error in one or more channels, the bit corresponding to the channels turns to "1." The bit corresponding to unmounted channels turns to "1."

DC current output modules check output wire breakdown to alert as an error. The bit corresponding to the channels turns to "1."

In the Data Allocation Mode 2, among the two bits assigned for each module, the least significant bit is used for channel 1 of a two-channel analog module or for a discrete module.

• Data Allocation Mode 1

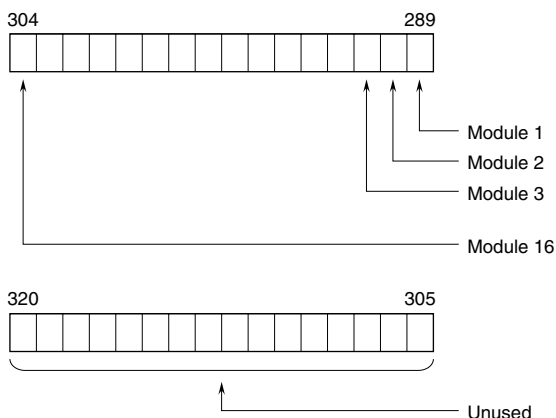

• Data Allocation Mode 2

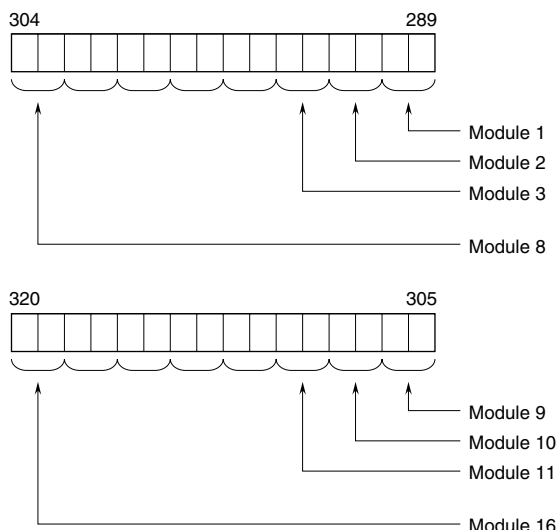

I/O DATA DESCRIPTIONS

The data allocations for typical I/O modules are shown below.
Refer to the manual for each module for detailed data allocations.

■ 16-BIT ANALOG DATA (models: R5-SV, YV, DS, YS, RS, TS, etc.)

0 to 100% of the selected I/O range is converted into 0 to 10000 (binary).

With °C or Kelvin temperature unit, raw data is multiplied by 10. For example, 25.5°C is converted into 255.

With °F temperature unit, the integer section of raw data is directly converted into the data. For example, 135.4°F is converted into 135.

Negative values are represented in 2's complements.



■ 4-POINT DISCRETE DATA (models: R5-DA4, DC4, etc.)

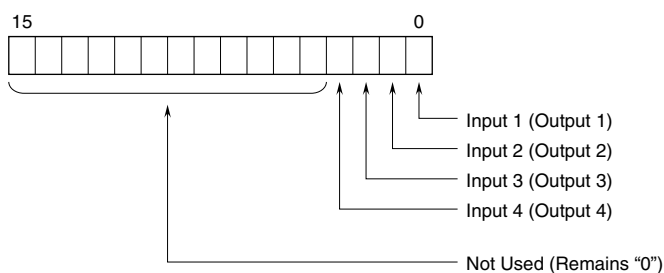

0 : OFF
1 : ON

■ 16-POINT DISCRETE DATA (models: R5-DA16, DC16, etc.)

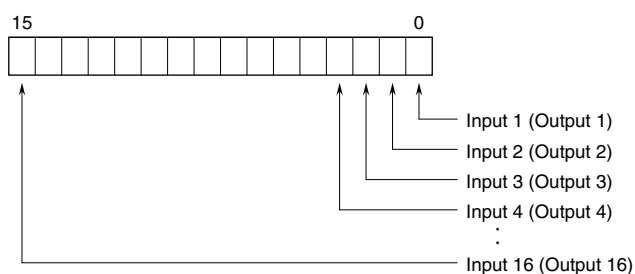

0 : OFF
1 : ON