

BEFORE USE

Thank you for choosing M-System. Before use, please check contents of the package you received as outlined below.

If you have any problems or questions with the product, please contact M-System's Sales Office or representatives.

■ PACKAGE INCLUDES:

Network module.....(1)

■ MODEL NO.

Confirm Model No. marking on the product to be exactly what you ordered.

■ INSTRUCTION MANUAL

This manual describes necessary points of caution when you use this product, including installation, connection and basic maintenance procedures.

■ ESI FILE

ESI files are downloadable at M-System's web site: <http://www.m-system.co.jp>

POINTS OF CAUTION

■ CONFORMITY WITH EU DIRECTIVES

- The equipment must be mounted inside the instrument panel of a metal enclosure.
- The actual installation environments such as panel configurations, connected devices, connected wires, may affect the protection level of this unit when it is integrated in a panel system. The user may have to review the CE requirements in regard to the whole system and employ additional protective measures to ensure the CE conformity.

■ HOT-SWAPPABLE MODULES

- It is possible to replace the module with the power supplied.
- Turn off signals before replacing the module for safety. Note that replacing multiple modules at once may greatly change line voltage levels. We highly recommend to replace them one by one.

■ ENVIRONMENT

- Indoor use.
- When heavy dust or metal particles are present in the air, install the unit inside proper housing with sufficient ventilation.
- Do not install the unit where it is subjected to continuous vibration. Do not subject the unit to physical impact.
- Environmental temperature must be within -10 to +55°C (14 to 131°F) with relative humidity within 10 to 90% RH in order to ensure adequate life span and operation.

■ WIRING

- Do not install cables close to noise sources (relay drive cable, high frequency line, etc.).
- Do not bind these cables together with those in which noises are present. Do not install them in the same duct.



EtherCAT® is a registered trademark and patented technology, licensed by Beckhoff Automation GmbH, Germany.

The product name of devices that input or output signal is "module." For example, the name of model R30SV2 is "DC Voltage/Current Input Module." Also, the EtherCAT uses the name of "module" as a unit to handle the device. In order to distinguish hardware of the device from the unit EtherCAT handles, the word "card" is used in this manual.

COMPONENT IDENTIFICATION

■ FRONT VIEW

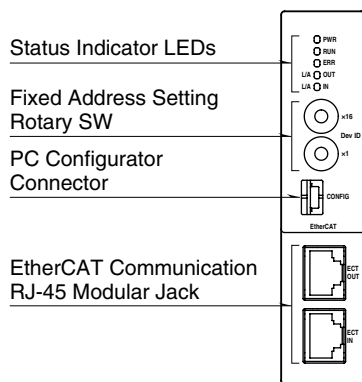

■ SIDE VIEW

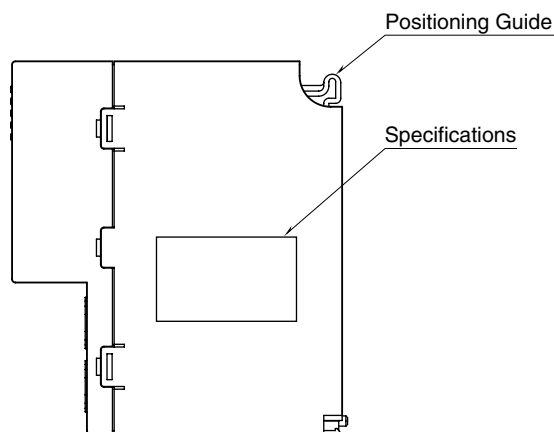

■ BOTTOM VIEW

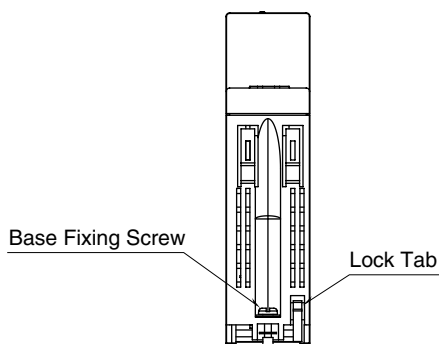

■ STATUS INDICATOR LED

ID	FUNCTION	COLOR	STATUS	
			Indicator State	Meaning
PWR	Main unit internal power	Green	Off	Error
			On	Normal
RUN	Device state	Green	Off	INIT
			Blinking	PRE-OPERATIONAL
			Single Flash	SAFE-OPERATIONAL
			On	OPERATIONAL
ERR	Error	Red	Off	No error
			Blinking	Invalid Configuration
			Single Flash	Local error
L/A IN	IN port status	Green	On	Application Controller failure
			Off	No Link
			Flickering	Link and activity
L/A OUT	OUT port status	Green	On	Link without activity
			Off	No Link
			Flickering	Link and activity
			On	Link without activity

Blinking	200ms-On, 200ms-Off
Single Flash	200ms-On, 1000ms-Off
Flickering	50ms-On, 50ms-Off

■ FIXED ADDRESS

Fixed address 1 to 255 can be set using the two rotary switches each marked 0 to F in combination.

When fixed address is not used, set the ID selector to 0.

Settable range: 0 to 255

Factory default: 0



Fixed Address Setting (x16)



Fixed Address Setting (x1)

INSTALLATION

■ INSTALLATION TO THE BASE

Use the Installation Base (model: R30BS).

The mounting slot for the network card is fixed to COM. Do not mount the network card to any other slot.

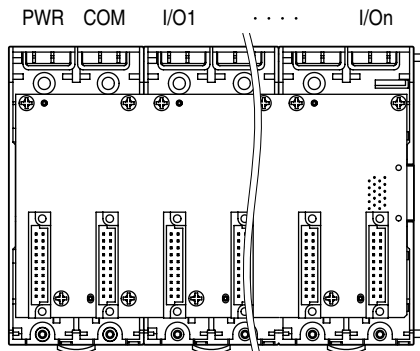

■ HOW TO MOUNT THE MODULE

- 1) Engage the positioning guide of the module with the Installation Base.
- 2) Pivot the module on the positioning guide and press it down until the lock tab sits into place.

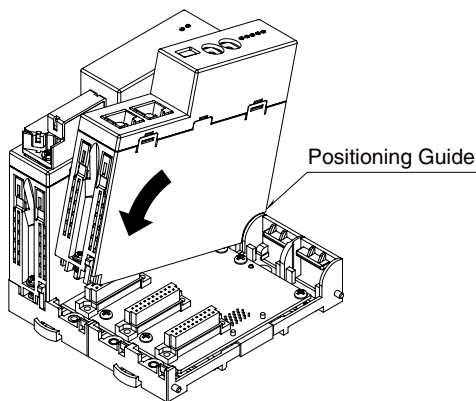

■ HOW TO REMOVE THE MODULE

- 1) Loosen the base fixing screw using a screwdriver (stem length: 70 mm/2.76" or more).

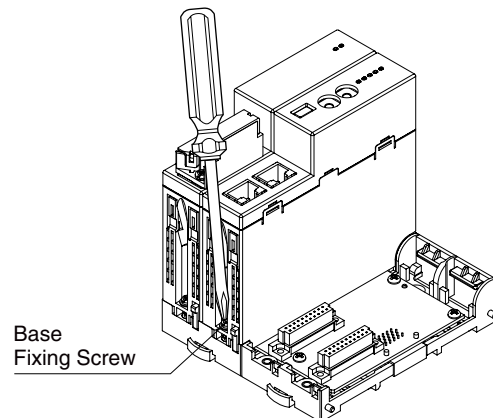

- 2) While pressing the projection on the lock tab, push the module upward.
- 3) Detach the positioning guide of the module from the Installation Base.

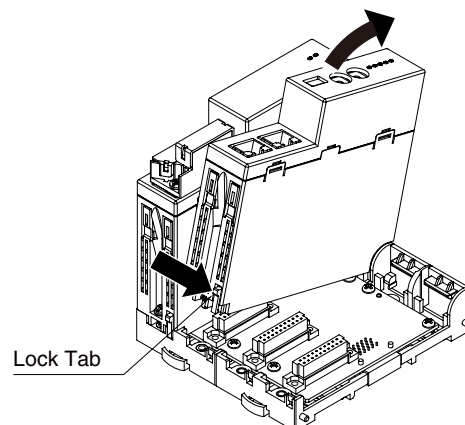

- 3) Tighten the base fixing screw using a screwdriver (stem length: 70 mm/2.76" or more) (torque 0.5 N·m).

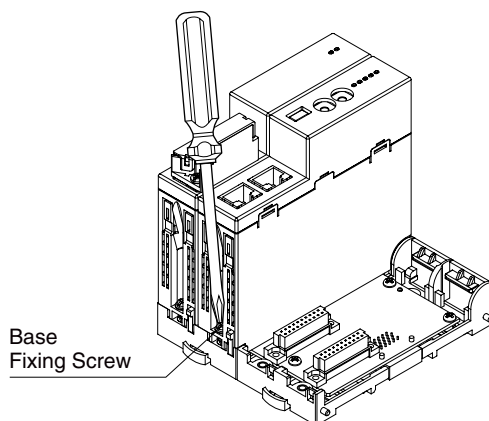

TERMINAL CONNECTIONS

Connect the unit as in the diagram below.

EXTERNAL DIMENSIONS unit : mm (inch)

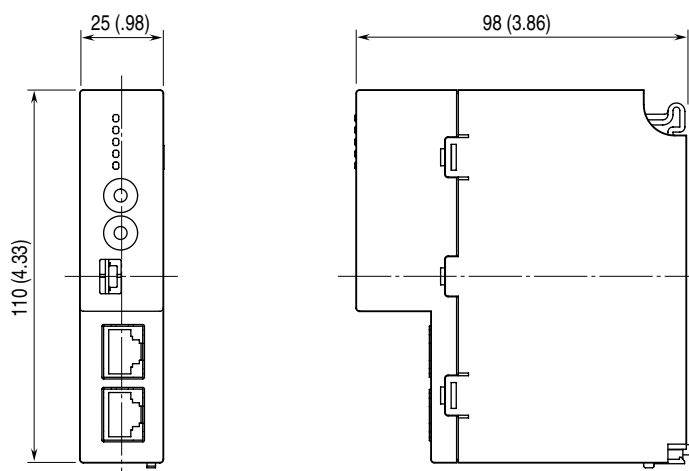

CONNECTION DIAGRAM

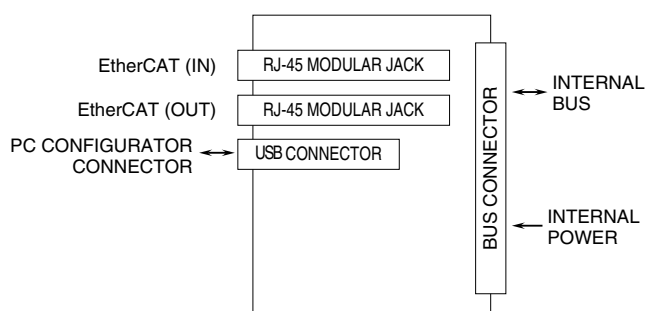

EtherCAT SPECIFICATIONS

■ Modular Device Profile

R30NECT1 complies with the Modular Device Profile (MDP) standard, ETG.5001.1 of the EtherCAT standard. Be sure that the master supports the MDP standard.

■ Fixed Address

R30NECT1 supports Explicit Device Identification by allowing setting of fixed address using the fixed address setting rotary switches (ID selector).

The fixed address can be set to be 1 to 255.

When fixed address is not used, set the ID selector to 0.

When the power is turned on with the ID selector set to other than 0, the designated address is written in the resistor 0x0012 of ESC (EtherCAT Slave Controller) when R30NECT1 starts up.

■ Process Data Configuration

R30NECT1 configures process data by module, as '1 address = 1 module'. One R30NECT1 can manage max. 32 modules.

I/O modules and their respective module types are as follows.

For the module types of I/O cards, refer to the specifications of the respective I/O cards.

Table 1: I/O Modules And Module Types

I/O MODULE	MODULE TYPE
DI16	Discrete input, 16 points
DI32	Discrete input, 32 points
DI64	Discrete input, 64 points
DO16	Discrete output, 16 points
DO32	Discrete output, 32 points
DO64	Discrete output, 64 points
DIO16	Discrete input, 16 points; Discrete output, 16 points
AI2	Analog input, 2 points
AI4	Analog input, 4 points
AI8	Analog input, 8 points
AI16	Analog input, 16 points
AO2	Analog output, 2 points
AO4	Analog output, 4 points
AO8	Analog output, 8 points
AO16	Analog output, 16 points
AIO4	Analog input, 4 points; Analog output, 4 points
AIO8	Analog input, 8 points; Analog output, 8 points
AIO16	Analog input, 16 points; Analog output, 16 points

■ Data Configuration

The data configuration is in accordance with the EtherCAT Modular Device Profile (MDP) specifications.

Table 2: Data Configuration

OBJECT	ADDRESS	CONTENT
Input Area Objects	0x6000 to 0x61F0	Input data
Output Area Objects	0x7000 to 0x71F0	Output data
PDO Mapping Objects (TxPDO)	0x1A00 to 0x1A1F	Input data list
PDO Mapping Objects (TxPDO)	0x1AFF	Status data list
PDO Mapping Objects (RxPDO)	0x1600 to 0x161F	Output data list
Manufacturer Specific Objects	0x2000, 0x2001	Card status
PDO Assign (IN)	0x1C13	Input data transmission order
PDO Assign (OUT)	0x1C12	Output data transmission order
Sync Manager Type	0x1C00	Sync manager type
Sync Manager Parameter Objects	0x1C32, 0x1C33	Sync mode
Information Data Objects	0x9000 to 0x91F0	Card information
Modular Device Profile Objects	0xF000	MDP information
Detected Module Ident List	0xF050	Card information list
Configured Module Ident List	0xF030	Card information collation by master module
Detected Address List	0xF040	I/O card address
Device Type	0x1000	Device type
Manufacturer Device Name	0x1008	Device name
Manufacturer Hardware Version	0x1009	Hardware version
Manufacturer Software Version	0x100A	Software version
Identity Objects	0x1018	Vendor information

■ EtherCAT State

EtherCAT defines four states of slave: INIT, PREOP, SAFEOP, and OP.

TxPDO (input configuration data) is updated only in the SAFEOP or OP state, and RxPDO (output configuration data) is updated only in the OP state.

When R30NECT1 is connected to EtherCAT, the RUN LED turns on and data is updated only in the OP state.

■ EtherCAT Diagnostics

• AL Status Code

When the slave (R30NECT1) fails to receive a request from the master or when there is a problem with the slave during normal communication, an error code is set to registers 0x0134 and 0x0135 (AL Status Code) of ESC. The error codes that R30NECT1 uses are as shown below. (Refer to Table 3.)

Table 3: Error Codes of AL Status Code

CODE	ERROR
0x0000	No error
0x0011	Invalid requested state change
0x0012	Unknown requested state
0x0013	BOOT state not supported
0x0016	Invalid MailBox configuration (PREOP)
0x0017	Invalid SyncManager configuration
0x001B	SyncManager Watchdog
0x001D	Invalid Output Configuration
0x001E	Invalid Input Configuration
0x001F	Invalid Watchdog Configuration
0x0029	FreeRun needs 3Buffer mode
0x8000	Internal bus error at power on (vendor option)
0x8001	Internal bus error during communication (vendor option)

• SDO Abort Code

When the master attempts to access the object dictionary via SDO, if the slave (R30NECT1) fails to receive SDO messages for any reason, R30NECT1 sends an error code (SDO Abort Code) to the master and denies its access. The following error codes are used. (Refer to Table 4.)

Table 4: Error Codes of SDO Abort Code

CODE	ERROR
0x05030000	Toggle bit not changed
0x05040001	Client/Server command specifier not valid or unknown
0x05040005	Out of memory
0x06010000	Unsupported access to an object
0x06010002	Attempt to a read-only object
0x06020000	The object does not exist in the object directory
0x06070010	Data type does not match, length of service parameter does not match
0x06090011	Sub-index does not exist
0x08000020	Data cannot be transferred or stored to the application
0x08000022	Data cannot be transferred or stored to the application because of the present device state

OBJECT DICTIONARY (DATA DESCRIPTION)

■ Input Area Objects (Input Data Area: 0x6000 to 0x61F0)

Input data of I/O modules is allocated to 0x6000 to 0x61F0. One card uses one object. Index of the object (address) is fixed by module number (0 to 31 = I/O slot number -1.)

$$\text{Object index} = 0x6000 + (\text{module number}) \times 0x0010$$

The configuration of the object is fixed by the number of input points and the data type per input point. Sub-Indexes correspond to channel numbers. (Refer to Tables 5 and 6.)

■ Output Area Objects (Output Data Area: 0x7000 to 0x71F0)

Output data of I/O modules is allocated to 0x7000 to 0x71F0. One card uses one object. Index of the object (address) is fixed by the mounting slot.

$$\text{Object index} = 0x7000 + (\text{module number}) \times 0x0010$$

The configuration of the object is fixed by the number of output points and the data type per output point. Sub-Indexes correspond to channel numbers. (Refer to Tables 5 and 6.)

Table 5: Object Configuration Example For I/O Card

MODULE NO.	MODEL	I/O MODULE	MODULE TYPE	OBJECT INDEX	DATA TYPE
0	R30XN16A	DI16	Discrete input, 16 points	0x6000	1 bit × 16
1	R30YN16A	DO16	Discrete output, 16 points	0x7010	1 bit × 16
2	R30YN16C	DO16	Discrete output, 16 points	0x7020	1 bit × 16
3	R30SV4	AI4	Analog input, 4 points	0x6030	16 bits × 4

Table 6: Sub-Index Configuration By Module Type

MODULE TYPE	INDEX	SUB-INDEX	DATA TYPE	BIT	ACCESS	VALUE	CONTENT
Discrete input, 16 points	0x6nn0	0	UINT8	8	RO	16	Number of items
		1	BOOL	1	RO	TRUE/FALSE	First point input data
		2	BOOL	1	RO	TRUE/FALSE	Second point input data
		:	:	:	:	:	:
		16	BOOL	1	RO	TRUE/FALSE	16th point input data
Discrete input, 32 points	0x6nn0	0	UINT8	8	RO	32	Number of items
		1	BOOL	1	RO	TRUE/FALSE	First point input data
		2	BOOL	1	RO	TRUE/FALSE	Second point input data
		:	:	:	:	:	:
		32	BOOL	1	RO	TRUE/FALSE	32nd point input data
Discrete input, 64 points	0x6nn0	0	UINT8	8	RO	64	Number of items
		1	BOOL	1	RO	TRUE/FALSE	First point input data
		2	BOOL	1	RO	TRUE/FALSE	Second point input data
		:	:	:	:	:	:
		64	BOOL	1	RO	TRUE/FALSE	64th point input data
Discrete output, 16 points	0x7nn0	0	UINT8	8	RO	16	Number of items
		1	BOOL	1	RO	TRUE/FALSE	First point output data
		2	BOOL	1	RO	TRUE/FALSE	Second point output data
		:	:	:	:	:	:
		16	BOOL	1	RO	TRUE/FALSE	16th point output data
Discrete output, 32 points	0x7nn0	0	UINT8	8	RO	32	Number of items
		1	BOOL	1	RO	TRUE/FALSE	First point output data
		2	BOOL	1	RO	TRUE/FALSE	Second point output data
		:	:	:	:	:	:
		32	BOOL	1	RO	TRUE/FALSE	32nd point output data
Discrete output, 64 points	0x7nn0	0	UINT8	8	RO	64	Number of items
		1	BOOL	1	RO	TRUE/FALSE	First point output data
		2	BOOL	1	RO	TRUE/FALSE	Second point output data
		:	:	:	:	:	:
		64	BOOL	1	RO	TRUE/FALSE	64th point output data

MODULE TYPE	INDEX	SUB-INDEX	DATA TYPE	BIT	ACCESS	VALUE	CONTENT
Discrete input, 16 points Discrete output, 16 points	0x6nn0	0	UINT8	8	RO	16	Number of items
		1	BOOL	1	RO	TRUE/FALSE	First point input data
		2	BOOL	1	RO	TRUE/FALSE	Second point input data
		:	:	:	:	:	:
		16	BOOL	1	RO	TRUE/FALSE	16th point input data
	0x7nn0	0	UINT8	8	RO	16	Number of items
		1	BOOL	1	RO	TRUE/FALSE	First point output data
		2	BOOL	1	RO	TRUE/FALSE	Second point output data
		:	:	:	:	:	:
		16	BOOL	1	RO	TRUE/FALSE	16th point output data
Analog input, 2 points	0x6nn0	0	UINT8	8	RO	2	Number of items
		1	INT16	16	RO	0x0000 to 0xFFFF	First point input data
		2	INT16	16	RO	0x0000 to 0xFFFF	Second point input data
Analog input, 4 points	0x6nn0	0	UINT8	8	RO	4	Number of items
		1	INT16	16	RO	0x0000 to 0xFFFF	First point input data
		2	INT16	16	RO	0x0000 to 0xFFFF	Second point input data
		3	INT16	16	RO	0x0000 to 0xFFFF	Third point input data
		4	INT16	16	RO	0x0000 to 0xFFFF	Fourth point input data
Analog input, 8 points	0x6nn0	0	UINT8	8	RO	8	Number of items
		1	INT16	16	RO	0x0000 to 0xFFFF	First point input data
		2	INT16	16	RO	0x0000 to 0xFFFF	Second point input data
		:	:	:	:	:	:
		8	INT16	16	RO	0x0000 to 0xFFFF	8th point input data
Analog input, 16 points	0x6nn0	0	UINT8	8	RO	16	Number of items
		1	INT16	16	RO	0x0000 to 0xFFFF	First point input data
		2	INT16	16	RO	0x0000 to 0xFFFF	Second point input data
		:	:	:	:	:	:
		16	INT16	16	RO	0x0000 to 0xFFFF	16th point input data
Analog output, 2 points	0x7nn0	0	UINT8	8	RO	2	Number of items
		1	INT16	16	RO	0x0000 to 0xFFFF	First point output data
		2	INT16	16	RO	0x0000 to 0xFFFF	Second point output data
Analog output, 4 points	0x7nn0	0	UINT8	8	RO	4	Number of items
		1	INT16	16	RO	0x0000 to 0xFFFF	First point output data
		2	INT16	16	RO	0x0000 to 0xFFFF	Second point output data
		3	INT16	16	RO	0x0000 to 0xFFFF	Third point output data
		4	INT16	16	RO	0x0000 to 0xFFFF	Fourth point output data
Analog output, 8 points	0x7nn0	0	UINT8	8	RO	8	Number of items
		1	INT16	16	RO	0x0000 to 0xFFFF	First point output data
		2	INT16	16	RO	0x0000 to 0xFFFF	Second point output data
		:	:	:	:	:	:
		8	INT16	16	RO	0x0000 to 0xFFFF	8th point output data
Analog output, 16 points	0x7nn0	0	UINT8	8	RO	16	Number of items
		1	INT16	16	RO	0x0000 to 0xFFFF	First point output data
		2	INT16	16	RO	0x0000 to 0xFFFF	Second point output data
		:	:	:	:	:	:
		16	INT16	16	RO	0x0000 to 0xFFFF	16th point output data
Analog input, 4 points Analog output, 4 points	0x6nn0	0	UINT8	8	RO	4	Number of items
		1	INT16	16	RO	0x0000 to 0xFFFF	First point input data
		2	INT16	16	RO	0x0000 to 0xFFFF	Second point input data
		3	INT16	16	RO	0x0000 to 0xFFFF	Third point input data
	0x7nn0	0	UINT8	8	RO	4	Number of items
		1	INT16	16	RO	0x0000 to 0xFFFF	First point output data
		2	INT16	16	RO	0x0000 to 0xFFFF	Second point output data
		3	INT16	16	RO	0x0000 to 0xFFFF	Third point output data
0x7nn0	0	UINT8	8	RO	4	Number of items	
	1	INT16	16	RO	0x0000 to 0xFFFF	First point output data	
	2	INT16	16	RO	0x0000 to 0xFFFF	Second point output data	
	4	INT16	16	RO	0x0000 to 0xFFFF	Fourth point output data	

MODULE TYPE	INDEX	SUB-INDEX	DATA TYPE	BIT	ACCESS	VALUE	CONTENT
Analog input, 8 points Analog output, 8 points	0x6nn0	0	UINT8	8	RO	8	Number of items
		1	INT16	16	RO	0x0000 to 0xFFFF	First point input data
		2	INT16	16	RO	0x0000 to 0xFFFF	Second point input data
		:	:	:	:	:	:
		8	INT16	16	RO	0x0000 to 0xFFFF	8th point input data
	0x7nn0	0	UINT8	8	RO	8	Number of items
		1	INT16	16	RO	0x0000 to 0xFFFF	First point output data
		2	INT16	16	RO	0x0000 to 0xFFFF	Second point output data
		:	:	:	:	:	:
		8	INT16	16	RO	0x0000 to 0xFFFF	8th point output data
Analog input, 16 points Analog output, 16 points	0x6nn0	0	UINT8	8	RO	16	Number of items
		1	INT16	16	RO	0x0000 to 0xFFFF	First point input data
		2	INT16	16	RO	0x0000 to 0xFFFF	Second point input data
		:	:	:	:	:	:
		16	INT16	16	RO	0x0000 to 0xFFFF	16th point input data
	0x7nn0	0	UINT8	8	RO	16	Number of items
		1	INT16	16	RO	0x0000 to 0xFFFF	First point output data
		2	INT16	16	RO	0x0000 to 0xFFFF	Second point output data
		:	:	:	:	:	:
		16	INT16	16	RO	0x0000 to 0xFFFF	16th point output data

■ Manufacturer Specific Objects (Card Status: 0x2000, 0x2001)

Status information of each I/O card is allocated to 0x2000 and mounting information of I/O cards is allocated to 0x2001.

Input abnormal data of module 0 to 31 (I/O card address 0 to 31) are stored in 0x2000 as 1 bit per channel (for a module with 4 channels, 4 bits). When the corresponding module is an analog input module and first point or second point input is out of -15 to +105% range, out of temperature table range or burnout state, the bit [second point: first point] of corresponding input is set to 1. When the corresponding module is other than the analog input module, [0:0] is set.

Status data of module 0 to 31 are stored in 0x2001 as 32 bits. LSB corresponds to module 0, MSB corresponds to module 31. A bit for normally existing module is set to 1, a bit for not existing module or module having a hardware error (including communication error) set to 0. (Refer to Table 7)

Table 7: Card Status Configuration

INDEX	SUB-INDEX	DATA TYPE	BIT	ACCESS	VALUE	CONTENT
0x2000	0	UINT8	8	RO	32	Number of items
	1	UINT16	16	RO	n	I/O card 1 status information
	2	UINT16	16	RO	n	I/O card 2 status information
	:	:	:	:	:	:
	32	UINT16	16	RO	n	I/O card 32 status information
0x2001	0	UINT8	8	RO	1	Number of items
	1	UINT32	32	RO	0xn timer	Mounting status of I/O cards

■ PDO Mapping Objects (Data List, TxPDO (input): 0x1A00 to 0x1A1F, RxPDO (output): 0x1600 to 0x161F)

Of the mounted I/O cards, input data list is allocated to TxPDO, output data list is allocated to RxPDO and status data list is allocated to 0x1AFF of TxPDO.

Object index (input data) = 0x1A00 + (module number)

Object index (output data) = 0x1600 + (module number)

RxPDO data and TxPDO data contain the object index, Sub-Index and number of bits of each I/O card.

Table 8: Object Configuration For RxPDO And TxPDO

INDEX	SUB-INDEX	DATA TYPE	BIT	ACCESS	VALUE	CONTENT
0x16nn (RxPDO)	0	UINT8	8	RO	1 to 16	Number of items
	1	UINT32	32	RO	0xaaaabbcc	aaaa: Index for I/O card bb: Sub-Index for I/O card cc: Number of bits for I/O card
	2	UINT32	32	RO		
	:	:	:	:		
	m	UINT32	32	RO		
0x1Ann (TxPDO)	0	UINT8	8	RO		
	1	UINT32	32	RO	0xaaaabbcc	aaaa: Index for I/O card bb: Sub-Index for I/O card cc: Number of bits for I/O card
	2	UINT32	32	RO		
	:	:	:	:		
	m	UINT32	32	RO		

Table 9: Configuration For Object 0x1AFF

INDEX	SUB-INDEX	DATA TYPE	BIT	ACCESS	VALUE	CONTENT
0x1AFF	0	UINT8	8	RO	33	Number of items
	1	UINT32	32	RO	0x20000110	Reference object
	2	UINT32	32	RO	0x20000210	
	:	:	:	:	:	
	32	UINT32	32	RO	0x20002010	
	33	UINT32	32	RO	0x20010120	

■ PDO Assign Objects (Data Transmission Order, Output: 0x1C12, Input: 0x1C13)

An allocation list for RxPDO and an allocation list for TxPDO are created in 0x1C12 and 0x1C13, respectively. The indexes stored in 0x1C12 and 0x1C13 are placed in the order they are actually transmitted via PDO.

• PDO group

Assignment of the PDO groups is based on the I/O card types as defined by Information Data Objects.

- PDO group 0: Status
- PDO group 1: Analog I/O card
- PDO group 2: Discrete I/O card

The PDO group data is transmitted in the following order of priority: Group 0 > Group 1 > Group 2.

Table 10 shows the PDO list for the card configuration example of Table 5.

Table 10: PDO List For The Configuration Example Of Table 5

INDEX	SUB-INDEX	DATA TYPE	BIT	ACCESS	PDO GROUP	VALUE	CONTENT
0x1C12	0	UINT8	8	RO	–	2	Number of items
	1	UINT16	16	RO	2	0x1601	Slot 2 output data
	2	UINT16	16	RO	2	0x1602	Slot 3 output data
0x1C13	0	UINT8	8	RO	–	3	Number of items
	1	UINT16	16	RO	0	0x1AFF	Status data
	2	UINT16	16	RO	2	0x1A00	Slot 1 input data
	3	UINT16	16	RO	2	0x1A03	Slot 4 input data

■ Sync Manager Type (0x1C00)

Sync Manager Type is allocated to object 0x1C00 based on the EtherCAT specification. (Refer to Table 11.)

Table 11: Object Configuration Of 0x1C00

INDEX	SUB-INDEX	DATA TYPE	BIT	ACCESS	VALUE	CONTENT
0x1C00	0	UINT8	8	RO	4	Number of items
	1	UINT8	8	RO	1	Mailbox Write
	2	UINT8	8	RO	2	Mailbox Read
	3	UINT8	8	RO	3	Process Output Data
	4	UINT8	8	RO	4	Process Input Data

■ Sync Manager Parameter Objects (0x1C32, 0x1C33)

These are Sync Mode setting objects. Objects 0x1C32 and 0x1C33 are fixed as R3ONECT1 only supports the Free Run mode. Distributed Clock (DC) mode is not supported.

■ Information Data Objects (0x9000 to 0x91F0)

Objects 0x9000 to 0x91F0 store the PDO group and Module Ident of I/O cards. (Refer to Table 13.)
The same number of objects as the number of I/O data items are allocated.

$$\text{Index} = 0x9000 + (\text{module number}) \times 0x0010$$

Sub-Index is 9 or 10. (Refer to Table 12.)

Table 12: Object 0x9nn0 Configuration

INDEX	SUB-INDEX	DATA TYPE	BIT	ACCESS	VALUE	CONTENT
0x9nn0	0	UINT8	8	RO	10	Number of items
	9	UINT16	16	RO	1/2	PDO Group
	10	UINT32	32	RO	1 to n	Module Ident

Table 13: PDO Group & Module Ident Of I/O Cards

I/O MODULE	MODULE TYPE	PDO GROUP	MODULE IDENT
DI16	Discrete Input, 16 points	2	101
DI32	Discrete Input, 32 points	2	102
DO16	Discrete Output, 16 points	2	103
DO32	Discrete Output, 32 points	2	104
AI4	Analog Input, 4 points	1	105
AI8	Analog Input, 8 points	1	106
AI16	Analog Input, 16 points	1	107
AO4	Analog Output, 4 points	1	108
AO8	Analog Output, 8 points	1	109
AO16	Analog Output, 16 points	1	110
DIO16	Discrete Input, 16 points; Discrete Output, 16 points	2	111
AIO16	Analog Input, 16 points; Analog Output, 16 points	1	112
AIO8	Analog Input, 8 points; Analog Output, 8 points	1	113
DI64	Discrete Input, 64 points	2	114
DO64	Discrete Output, 64 points	2	115
AI2	Analog Input, 2 points	1	116
AO2	Analog Output, 2 points	1	117
DI8	Discrete Input, 8 points	2	118
DO8	Discrete Output, 8 points	2	119
AIO4	Analog Input, 4 points; Analog Output, 4 points	1	120

■ Modular Device Profile Objects (0xF000)

Object 0xF000 contains Modular Device Profile (MDP). The Index interval is allocated to Sub-Index 1. The maximum number of cards is allocated to Sub-Index 2. And, the PDO group parameter of the slave device is allocated to Sub-Index 5. (Refer to Table 14.)

Sub-Index 4 indicates the valid/invalid statuses of object 0x9nn0 Sub-Indexes.

The allocations are as follows:

bit 0 = 0x9nn0 Sub-Index 1

bit 1 = 0x9nn0 Sub-Index 2

:

1: Valid, 2: Invalid

Table 14: Object 0xF000 Configuration

INDEX	SUB-INDEX	DATA TYPE	BIT	ACCESS	VALUE	CONTENT
0xF000	0	UINT8	8	RO	5	Number of items
	1	UINT16	16	RO	0x0010	Index Interval
	2	UINT16	16	RO	32	Maximum number of cards
	4	UINT32	32	RO	0x00000300	Valid Sub-Index of 0x9nn0
	5	UINT16	16	RO	0	PDO group

■ Detected Module Ident List (0xF050)

The list of Module Idents of the mounted I/O cards is allocated to object 0xF050.

The Sub-Index numbers are the same as the I/O slot numbers. The Sub-Index number of vacant I/O slots is 0. (Refer to Table 15.)

■ Configured Module Ident List (0xF030)

The master confirms the module configuration with object 0xF030.

With the Sub-Index numbers being the same as the I/O slot numbers, the master writes Module Idents to the modules it recognizes. The slave confirms the Module Ident: if it is correct, the writing has been successful; if there is any error, the writing has failed.

When all is correct, objects 0xF030 and 0xF050 show the same configuration. Object 0xF030 is solely for the confirmation by the master. The use of this object can be omitted. (Refer to the Table 15.)

Table 15: Object 0xF030 and 0xF050, Configuration

INDEX	SUB-INDEX	DATA TYPE	BIT	ACCESS	VALUE	CONTENT
0xF030	0	UINT8	8	RW	32	Number of items
	1	UINT32	32	RW	0 to n	Module Ident or 0
	2	UINT32	32	RW	0 to n	
	:	:	:	:	:	
	32	UINT32	32	RW	0 to n	
0xF050	0	UINT8	8	RO	32	Number of items
	1	UINT32	32	RO	0 to n	Module Ident or 0
	2	UINT32	32	RO	0 to n	
	:	:	:	:	:	
	32	UINT32	32	RO	0 to n	

■ Detected Address List (0xF040)

The addresses of mounted I/O cards are allocated in object 0xF040.

The Sub-Index numbers are same as the I/O slot numbers. The Sub-Index number of vacant I/O slots is 0. (Refer to Table 16.)

Table 16: Object 0xF040 Configuration

INDEX	SUB-INDEX	DATA TYPE	BIT	ACCESS	VALUE	CONTENT
0xF040	0	UINT8	8	RO	32	Number of items
	1	UINT32	32	RO	0 to n	I/O slot number or 0
	2	UINT32	32	RO	0 to n	
	:	:	:	:	:	
	32	UINT32	32	RO	0 to n	

■ Device Type (0x1000)

The device type of this network card is allocated to object 0x1000. The device type is 5001. (Refer to Table 17.)

Table 17: Object 0x1000 Configuration

INDEX	DATA TYPE	BIT	ACCESS	VALUE	CONTENT
0x1000	UINT32	32	RO	5001	Device type

■ Manufacturer Device Name (0x1008)

The model number of this network card is allocated to object 0x1008 in String form. (Refer to Table 18.)

Table 18: Object 0x1008 Configuration

INDEX	DATA TYPE	BIT	ACCESS	VALUE	CONTENT
0x1008	STRING	32	RO	R3ONECT1	Model number

■ Manufacturer Hardware Version (0x1009)

The hardware device version of this network card is allocated to object 0x1009 in String form. (Refer to Table 19.)

Table 19: Object 0x1009 Configuration

INDEX	DATA TYPE	BIT	ACCESS	VALUE	CONTENT
0x1009	STRING	32	RO	n.nn	Hardware version

■ Manufacturer Software Version (0x100A)

The software version of this network card is allocated to object 0x100A in String form. (Refer to Table 20.)

Table 20: Object 0x100A Configuration

INDEX	DATA TYPE	BIT	ACCESS	VALUE	CONTENT
0x100A	STRING	32	RO	n.nn	Software version

■ Identity Object (0x1018)

Information unique to this network card is allocated to object 0x1018. While the vendor ID and product code are fixed, the revision number is incremented by one at each major version up of the software.

A unique serial number is allocated to each product. (Refer to Table 22.)

A serial number consists of 8 digits, starting with two alpha-numeral characters followed by six numeral characters.

The serial number is expressed as 32-bit data divided into 6-bit, 6-bit and 20-bit groups, with the first two characters converted into 6-bit values. (Refer to Table 21.)

6 BITS	6 BITS	20 BITS
1st digit	2nd digit	3rd to 8th digits (000000 to 999999)

Table 21: Serial Number Conversion Table

CHARACTER	VALUE
0	0
1	1
:	:
9	9
A	10
B	11
:	:
Z	35

Table 22: Object 0x1018 Configuration

INDEX	SUB-INDEX	DATA TYPE	BIT	ACCESS	VALUE	CONTENT
0x1018	0	UINT8	8	RO	4	Number of items
	1	UINT32	32	RO	0x0000060C	Vendor ID
	2	UINT32	32	RO	0x52333001	Product code
	3	UINT32	32	RO	n	Revision number
	4	UINT32	32	RO	0 to n	Serial number