

Terminal Block Signal Conditioners with Display M50E-UNIT

MULTI POWER TRANSDUCER

(PC programmable)

Functions & Features

- Super-mini power transducer
- 5 to 600 A clamp CT use for current sensor
- Single-phase/2-wire, single-phase/3-wire 3-phase/3-wire and 3-phase/4-wire are available
- Single phase can measure up to four circuits, single-phase/3-wire, Three-phase/2-wire can measure up to two circuits
- High-density mounting
- Organic EL display

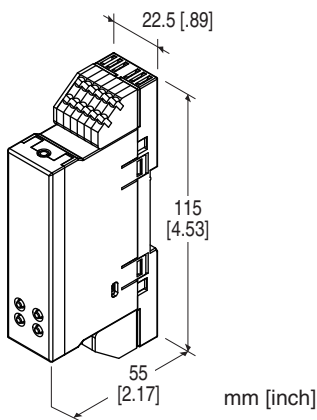

MODEL: M50EXWTU-223-AD4[1]

ORDERING INFORMATION

- Code number: M50EXWTU-223-AD4[1]
Specify a code from below for [1].
(e.g. M50EXWTU-223-AD4/Q)
- Specify the specification for option code /Q
(e.g. /C01/SET)

CONFIGURATION

- 2: Single phase / 2-wire and 3-wire,
3-phase / 3-wire and 4-wire

INPUT

- 2: 480 V AC / CLSE
Clamp-on current sensor is selectable from below.
CLSE (5A, 50A, 100A, 200A, 400A, 600A)
5A is available as CT's secondary.

EXTERNAL INTERFACE

3: Modbus communication

POWER INPUT

Universal

AD4: 100 - 240 V AC / 100 - 240 V DC (universal)
(Operational voltage range 85 - 264 V AC, 47 - 66 Hz /
85 - 264 V DC, ripple 10 %p-p max.)

[1] OPTIONS

blank: none

/Q: Options other than the above (specify the specification)

SPECIFICATIONS OF OPTION: Q (multiple selections)

COATING (For the detail, refer to our web site.)

/C01: Silicone coating

/C02: Polyurethane coating

/C03: Rubber coating

EX-FACTORY SETTING

/SET: Preset according to the Ordering Information Sheet
(No. ESU-3071)

RELATED PRODUCTS

- PC Configurator cable (model: COP-US)
- PC configurator software (model: PMCFG)
Downloadable at our web site.
- Clamp-on current sensor (model: CLSE)

GENERAL SPECIFICATIONS

Connection: Tension clamp terminal

Applicable wire size:

Lower connector (voltage input, power, Modbus)

0.2 - 1.5 mm², stripped length 8 - 9 mm

Upper connector (current sensor input, pulse output)

0.2 - 1.5 mm², stripped length 10 - 11 mm

Housing material: Flame-resistant resin (black)

Isolation: Voltage input or current input to Modbus to pulse
output 1 to pulse output 2 to power

Measured variables

Voltage: 1-N, 2-N, 3-N, 1-2, 2-3, 3-1

Current: 1, 2, 3, N

Active power

Reactive power

Apparent power

Power factor

Frequency

Active energy: Incoming / outgoing

Reactive energy: Incoming / outgoing / lag (inductive)
/lead (capacitive)

Harmonic distortion:

Overall distortion ratio, content rate (2nd to 31st)

Max. and min. values

CO₂ emissions (energy conversion value)

Simplified measurement mode: Calculates power from current values with fixed voltage values and power factor.

MODBUS COMMUNICATION

Communication: Half-duplex, asynchronous, no procedure

Standard: Conforms to TIA/EIA-485-A

Transmission distance: 500 meters max.

Baud rate: 1200, 2400, 4800, 9600, 19200, 38400 bps
(default: 38400 bps)

Protocol: Modbus RTU

Node address: 1 to 247 (default: 1)

Parity: None, even or odd (default: odd)

Stop bit: 1 or 2 (default: 1)

Max. number of nodes: 31 (excluding master)

Internal terminating resistor: 110 Ω

DISPLAY

Display functions: Displays measured value and status of the unit

Display size: Approx. 14 × 40 mm (0.55" × 1.57")

Character color: Yellow

Brightness: Standard or low brightness (default: standard)

Display life: Approx. 120,000 hours
(Expected time for the Display brightness to be reduced to 50 % when the Display is used continuously with low brightness in 25 °C)

Operating mode: Automatically turn off after no operation, or always on

(default: automatically turn off after no operation for 10 minutes)

Display type: OEL display

INPUT SPECIFICATIONS

Frequency: 50 / 60 Hz (45 - 66 Hz)

• **Voltage Input**

Rated voltage for each wiring:

- Single-phase/2-wire rated voltage 240 V AC
- Single-phase/3-wire phase voltage 240 V AC / line voltage 480 V AC
- Three-phase/3-wire line voltage 240 V AC (480 V AC when voltage to ground for each line is ≤ 277 V)
- Three-phase/4-wire phase voltage 277 V / line voltage 480 V AC

Input range: 1-N, 2-N, 3-N 50 to 277 V AC

1-2, 2-3, 3-1 50 to 480 V AC

Consumption VA: Voltage circuit ≤ $ULN^2 / 250$ kΩ / ph

Selectable primary voltage range: 50 - 400 000 V

• **Current Input**

Current sensor (default: CLSE-R5)

CLSE-R5: 0 - 5 A AC

CLSE-05: 0 - 50 A AC

CLSE-10: 0 - 100 A AC

CLSE-20: 0 - 200 A AC

CLSE-40: 0 - 400 A AC

CLSE-60: 0 - 600 A AC

Input range: 0 - 120% of the rating

Low-end cutout (current): 0 - 99.9% (default setting: 1%)

Selectable primary current range: 1 - 20 000 A (only with CLSE-R5, refer to the configurator settings)

OUTPUT SPECIFICATIONS

■ **Pulse output**

Outputs assignable to pulse: various energy

Output type: Photo MOSFET relay

Rated load: 30 V 200 mA AC/DC at peak

ON resistance: 1 Ω max.

Leakage current during opening: 2 μA max.

INSTALLATION

Power consumption

• **AC:** Max. 3 VA

• **DC:** ≤ 1.5 W

Operating temperature: -20 to +65°C (-4 to +149°F)

Operating humidity: 30 to 90 %RH (non-condensing)

Mounting: DIN rail

Weight: 90 g (0.2 lb)

PERFORMANCE

Accuracy^{*1}

Voltage: ±0.5 %^{*2}

Current: ±0.5 %^{*2}

Power: ±0.5 %^{*2}

Power factor: ±1.5 %

Frequency: ±0.1 Hz

Energy: ±2 % (power factor ≥ 0.5, input ≥ 10%)

*1. Sensor error margin not included. Add sensor error margin when using with the combination of the sensor.

*2. The described accuracy levels are ensured at the input 1% or more for neutral current in a single-phase/3-wire circuit, phase-2 current in a 3-phase/3-wire circuit and phase-N current in a 3-phase/4-wire circuit.

Temp. coefficient: ±0.0075 %/°C (0.004 %/°F)

Sampling time: ≤ 500 msec.

Insulation resistance: ≥ 100 MΩ with 500 V DC

Dielectric strength: 2000 V AC @ 1 minute

(current input or voltage input to Modbus to pulse output 1 or pulse output 2 to power)

500 V AC @ 1 minute (pulse output 1 to pulse output 2)

STANDARDS & APPROVALS

EU conformity:
 EMC Directive
 EMI EN 61000-6-4
 EMS EN 61000-6-2
 Low Voltage Directive
 EN 61010-1
 Measurement Category II (input)
 Installation Category II (power supply)
 Pollution Degree 2
 Voltage input to current input or Modbus or pulse output:
 Reinforced insulation (300 V)
 Power to current input or Modbus or pulse output:
 Reinforced insulation (300 V)
 RoHS Directive

EXTERNAL VIEW

TOP VIEW

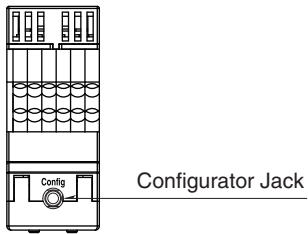

FRONT VIEW

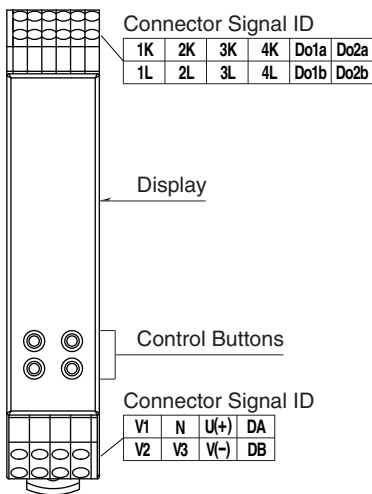

RIGHT VIEW

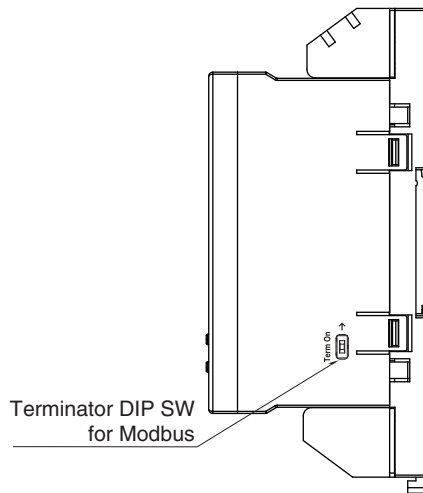

TERMINAL CONNECTIONS

System/ Application	Terminal	System/ Application	Terminal
Single-phase/ 2-wire 4-circuit		Single-phase/ two-wire branched from single-phase three-wire 4-circuit (Voltage can be selected from any line)	
Single-phase 3-wire 2-circuit		Single-phase/ 3-wire + Single-phase/ 2-wire 2-circuit (Voltage for single-phase/ 2-wire can be selected from any line)	
Three-phase/ 3-wire 2-circuit		Three-phase/ 4-wire	

Note: VT can be used for voltage input, but is omitted in this connecting diagram.
 Apply power voltage to V1-N for detecting frequency at simplified measurement (voltage and power factor are fixed).
 Select same current sensor for circuit A and B, and circuit C and D.

MODBUS WIRING CONNECTION

■ HOST PC WIRING

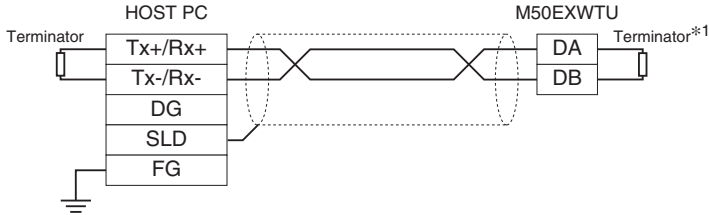

*1. Turn the terminator DIP SW ON to use internal terminator.

EXTERNAL DIMENSIONS unit: mm [inch]

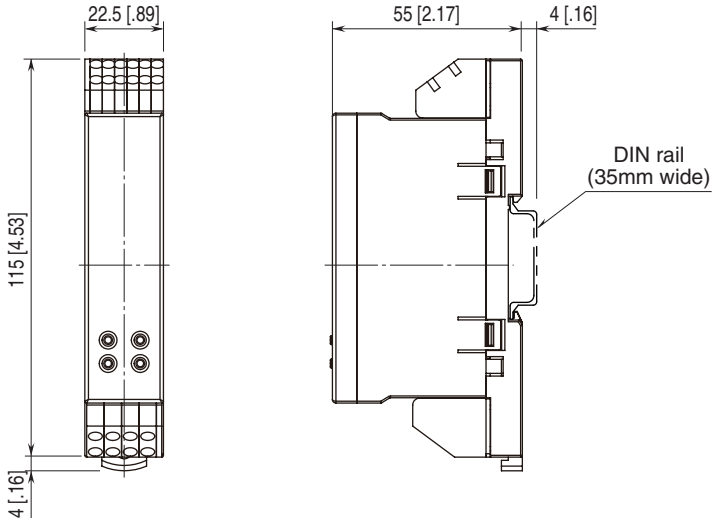

SCHEMATIC CIRCUITRY & CONNECTION DIAGRAM

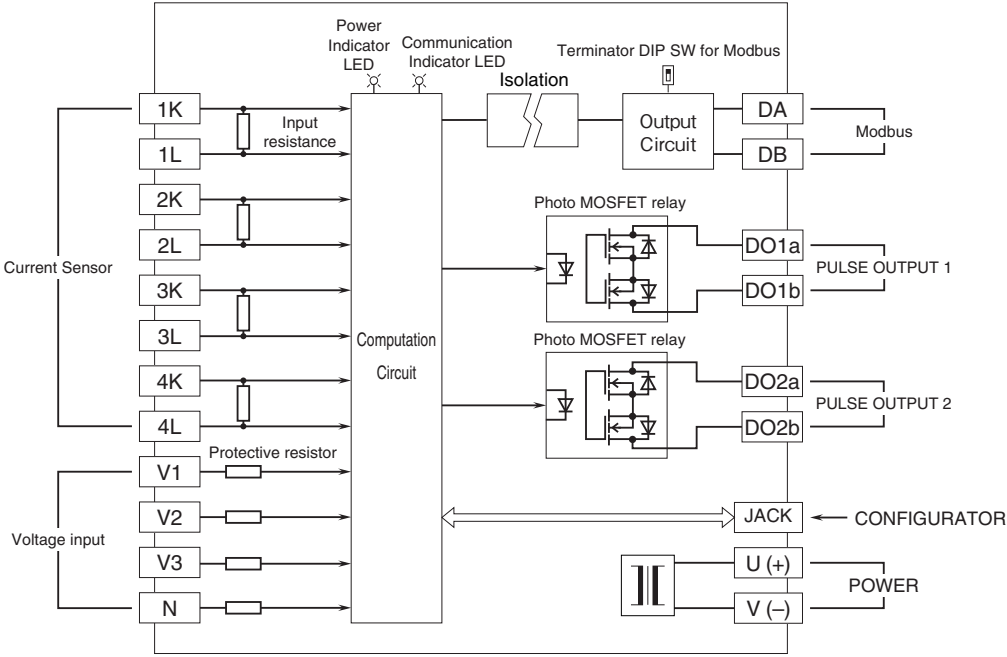

Specifications are subject to change without notice.