

MULTI POWER TRANSDUCER	MODEL LSMT4
-------------------------------	--------------------

BEFORE USE

Thank you for choosing us. Before use, please check contents of the package you received as outlined below.

If you have any problems or questions with the product, please contact our sales office or representatives.

■ PACKAGE INCLUDES:

- Multi Power Transducer(1)
- Output label for users(2)
- Upper mounting adaptor(2)

■ MODEL NO.

Confirm Model No. marking on the product to be exactly what you ordered.

■ INSTRUCTION MANUAL

This manual describes necessary points of caution when you use this product, including installation, connection and basic maintenance procedures.

The LSMT4 is programmable using the PC configurator software. For detailed information on the PC configuration, refer to the LSCFG instruction manual. The LSCFG PC Configurator Software is downloadable at our web site..

POINTS OF CAUTION

■ CONFORMITY WITH EU DIRECTIVES

- This equipment is suitable for Pollution Degree 2, Measurement Category II (input, transient voltage 4000V) and Installation Category II (transient voltage 2500V). Prior to installation, check that the insulation class of this unit satisfies the system requirements. Insulation class of this unit is as follows.

Input to output	Reinforced insulation (480V)
Output to auxiliary power	Reinforced insulation (300V)

- Altitude up to 2000 meters.
- The equipment must be mounted inside a panel.
- The equipment must be installed such that appropriate clearance and creepage distances are maintained to conform to CE requirements. Failure to observe these requirements may invalidate the CE conformance.
- The actual installation environments such as panel configurations, connected devices, connected wires, may affect the protection level of this unit when it is integrated in a panel system. The user may have to review the CE requirements in regard to the whole system and employ additional protective measures to ensure the CE conformity.
- Install lightning surge protectors for those wires connected to remote locations.

■ AUXILIARY POWER SUPPLY RATING & OPERATIONAL RANGE

- Locate the auxiliary power supply rating marked on the product and confirm its operational range as indicated below:
 - 100 – 240V AC rating: 85 – 264V AC, 50/60 Hz, < 20VA
 - 110 – 240V DC rating: 99 – 264V DC, < 9W
 - 24V DC rating: 24V±10%, < 9W
 - 48V DC rating: 48V±10%, < 9W

■ GENERAL PRECAUTION

- Before you remove or mount the unit, turn off the power supply and the input signal for safety.

■ ENVIRONMENT

- Indoor use.
- Do not install the unit where it is directly exposed to rain, water droplets or sunlight.
- When heavy dust or metal particles are present in the air, install the unit inside proper housing with sufficient ventilation.
- Do not install the unit where it is subjected to continuous vibration. Do not subject the unit to physical impact.
- Environmental temperature must be within -10 to +55°C (14 to 131°F) with relative humidity within 30 to 90% RH in order to ensure adequate life span and operation.

■ WIRING

- Do not install cables close to noise sources (relay drive cable, high frequency line, etc.).
- Do not bind these cables together with those in which noises are present. Do not install them in the same duct.

■ AND

- The unit is designed to function as soon as power is supplied, however, a warm up for 10 minutes is required for satisfying complete performance described in the data sheet.

LIGHTNING SURGE PROTECTION

We offer a series of lightning surge protector for protection against induced lightning surges. Please contact us to choose appropriate models.

COMPONENT IDENTIFICATION

■ FRONT VIEW

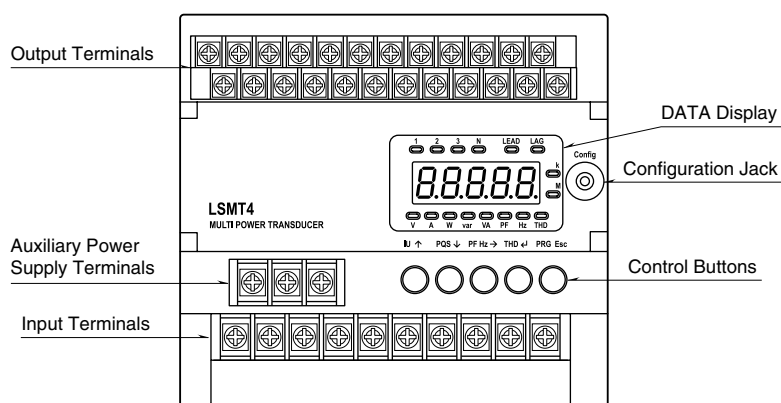

INSTALLATION

■ WALL MOUNTING

Attach the upper mounting adaptors to the upper side of the unit, and pull out the lower mounting adaptors from the lower side. Fasten a M4 screw through the mounting hole (4.5 mm dia.) of each adaptor. (torque 1.4 N·m)

To remove the upper mounting adaptor from the unit, pull it out while squeezing the latches as shown in the figure below.

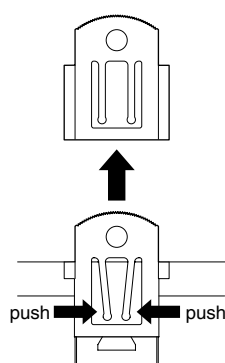

■ DIN RAIL MOUNTING

Set the unit so that the lower mounting adaptors are at the bottom. Hook the upper hook at the rear side of the unit onto the DIN rail and push in the lower part of the unit. When removing the unit, pull out the unit while pushing down the adaptors using a minus screwdriver.

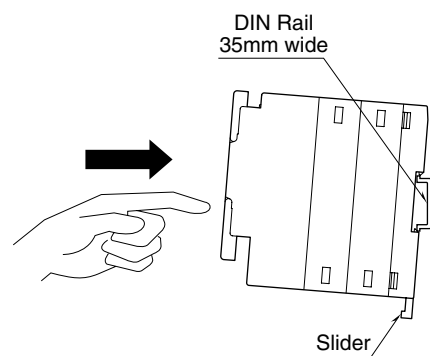

TERMINAL CONNECTIONS

Connect the unit as in the diagram below.

EXTERNAL DIMENSIONS unit: mm (inch)

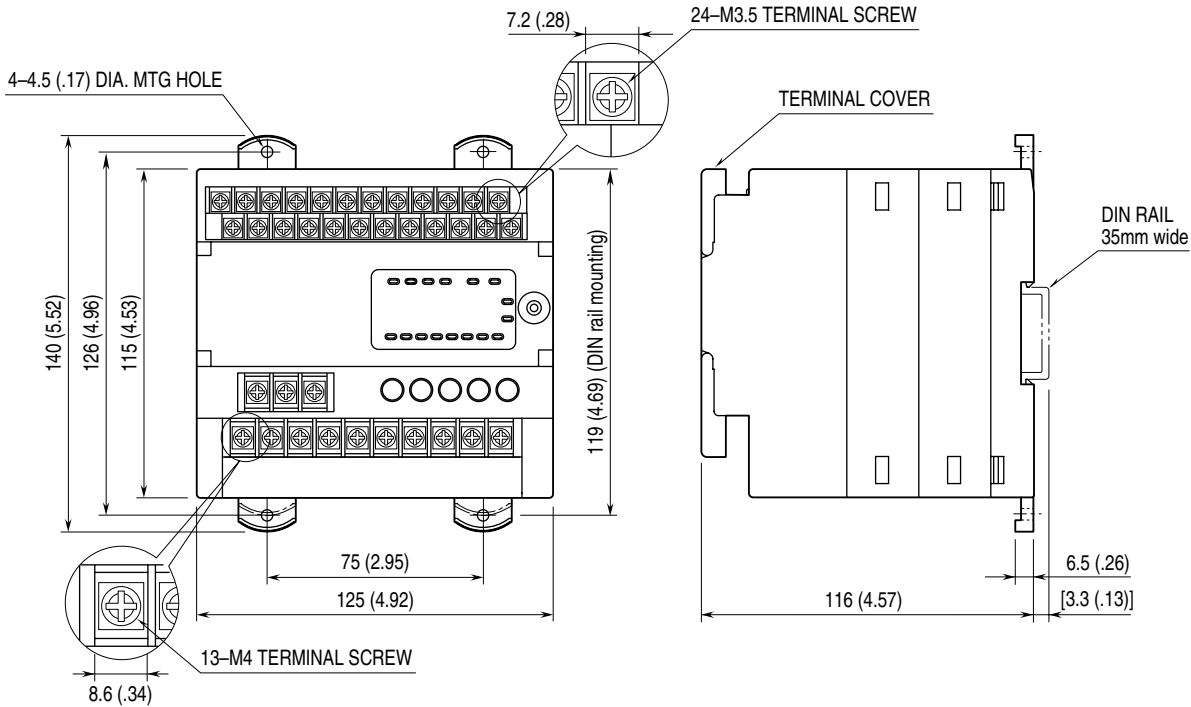

MOUNTING REQUIREMENTS unit: mm (inch)

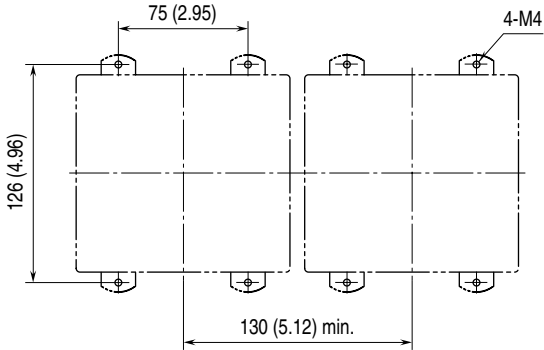

WIRING INSTRUCTIONS

■ SOLDERLESS TERMINAL unit: mm (inch)

Refer to the drawing below for recommended ring tongue terminal size. Spade tongue type is also applicable.

• M3.5 Screw (output)

Torqu: 0.6 N·m

Applicable wire size: 1.04 – 2.63 mm²

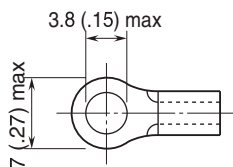

• M4 Screw (auxiliary power, voltage input, current input)

Torqu: 1.4 N·m

Applicable wire size: 1.04 – 6.64 mm²

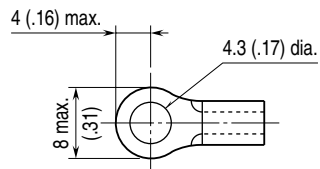

CONNECTION DIAGRAM

Note: In order to improve EMC performance, bond the FE terminal to ground.

Caution: FE terminal is NOT a protective conductor terminal.

■ TERMINAL ASSIGNMENT

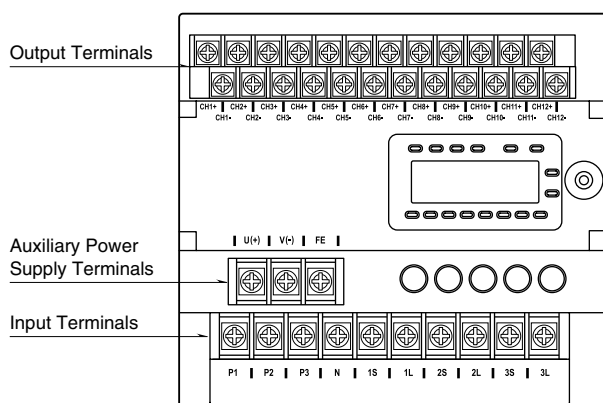

■ ELECTRICAL CONNECTION

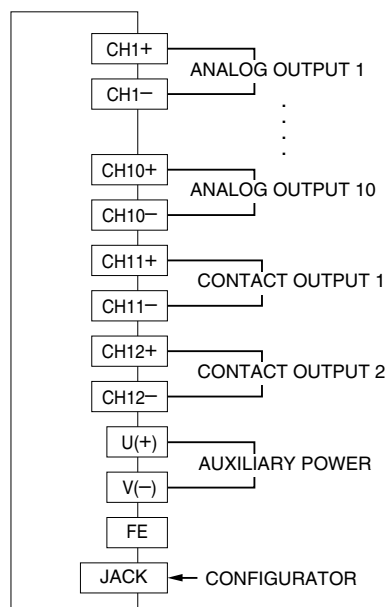

System / Application	Terminal	System / Application	Terminal
Single phase / 2-wire		3-phase / 3-wire, unbalanced load	
3-phase / 3-wire, balanced load		3-phase / 4-wire, balanced load	
Single phase / 3-wire		3-phase / 4-wire, unbalanced load	

Note: For low voltage circuit, grounding is not required.

OPERATING MODE

The measurement display items can be chosen with 4 buttons.

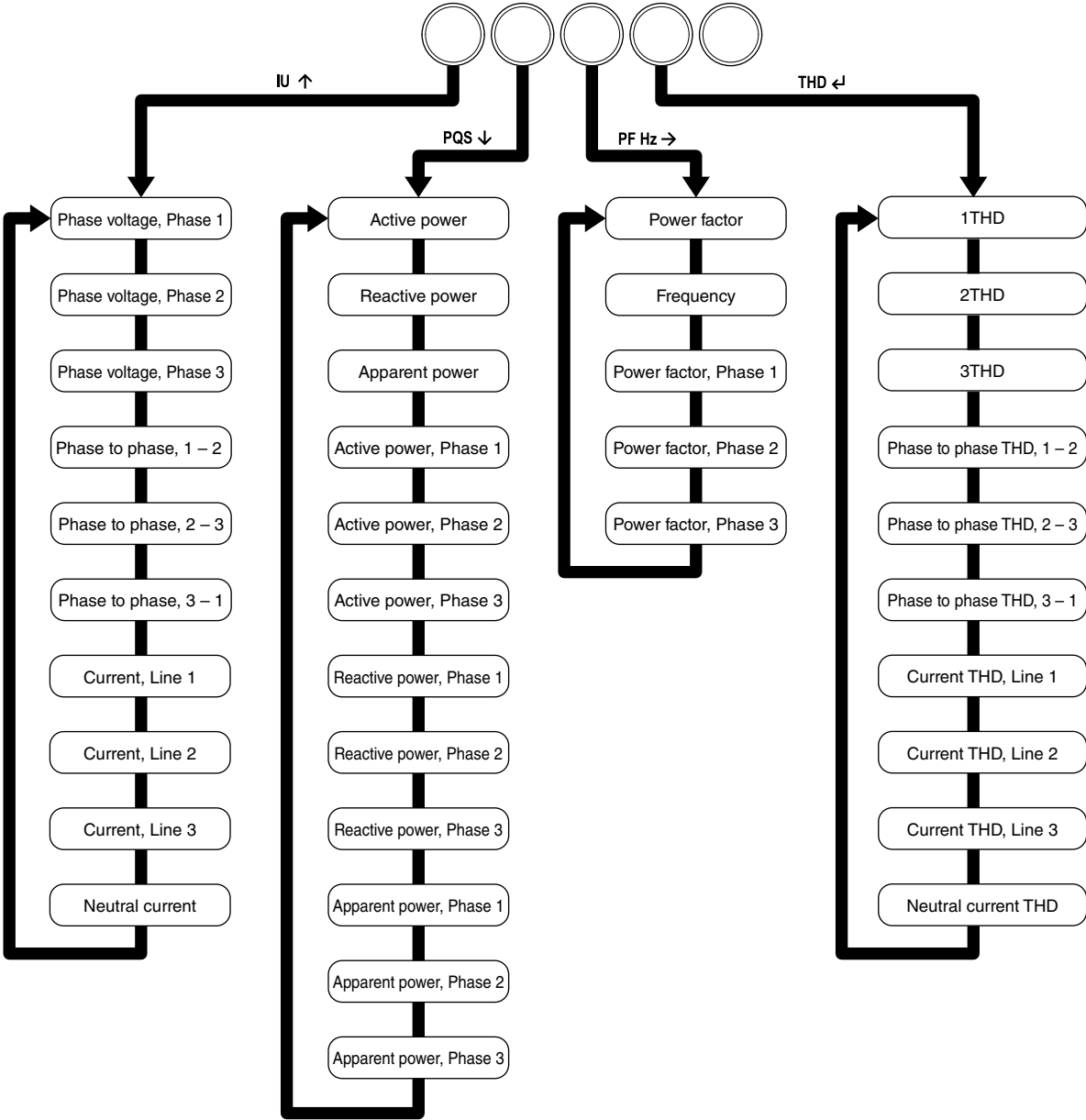
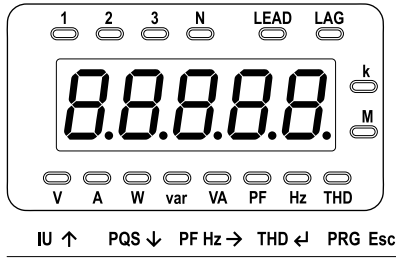

CHARACTER SET

0	1	2	3	4	5	6	7	8	9	-	A	B	C	D	E	F	G	H	I	J	K	L	M	N	O	P	Q	R	S	T	U	V	W	X	Y	Z
0	1	2	3	4	5	6	7	8	9	-	A	b	C	d	E	F	G	H	,	J	K	L	ñ	n	o	P	q	r	S	t	U	u	v	w	x	z

SETTING MODE

■ BUTTON OPERATION

Button	Menu/Item	Numeric Input
IU ↑ / PQS ↓	Move between Menu/Item	Increment/decrement at selected digit
THD ←	Select Menu/Item	Enter the value
PRG Esc	Escape from Menu/Item	Return without entering the value

■ SETTING MENU/SETTING GROUP MENU

• Flow chart

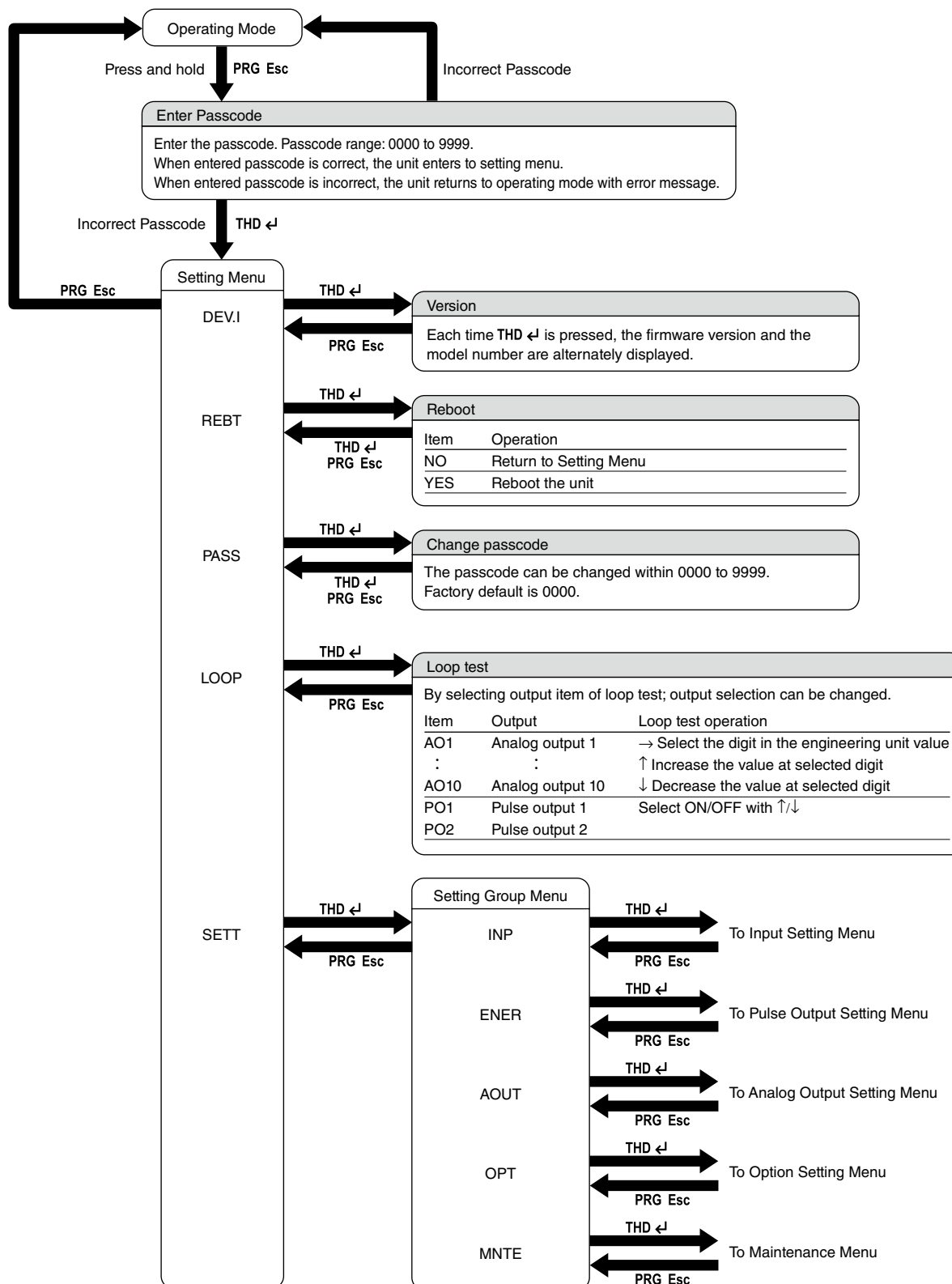

■ INP INPUT SETTING MENU

• Flow chart

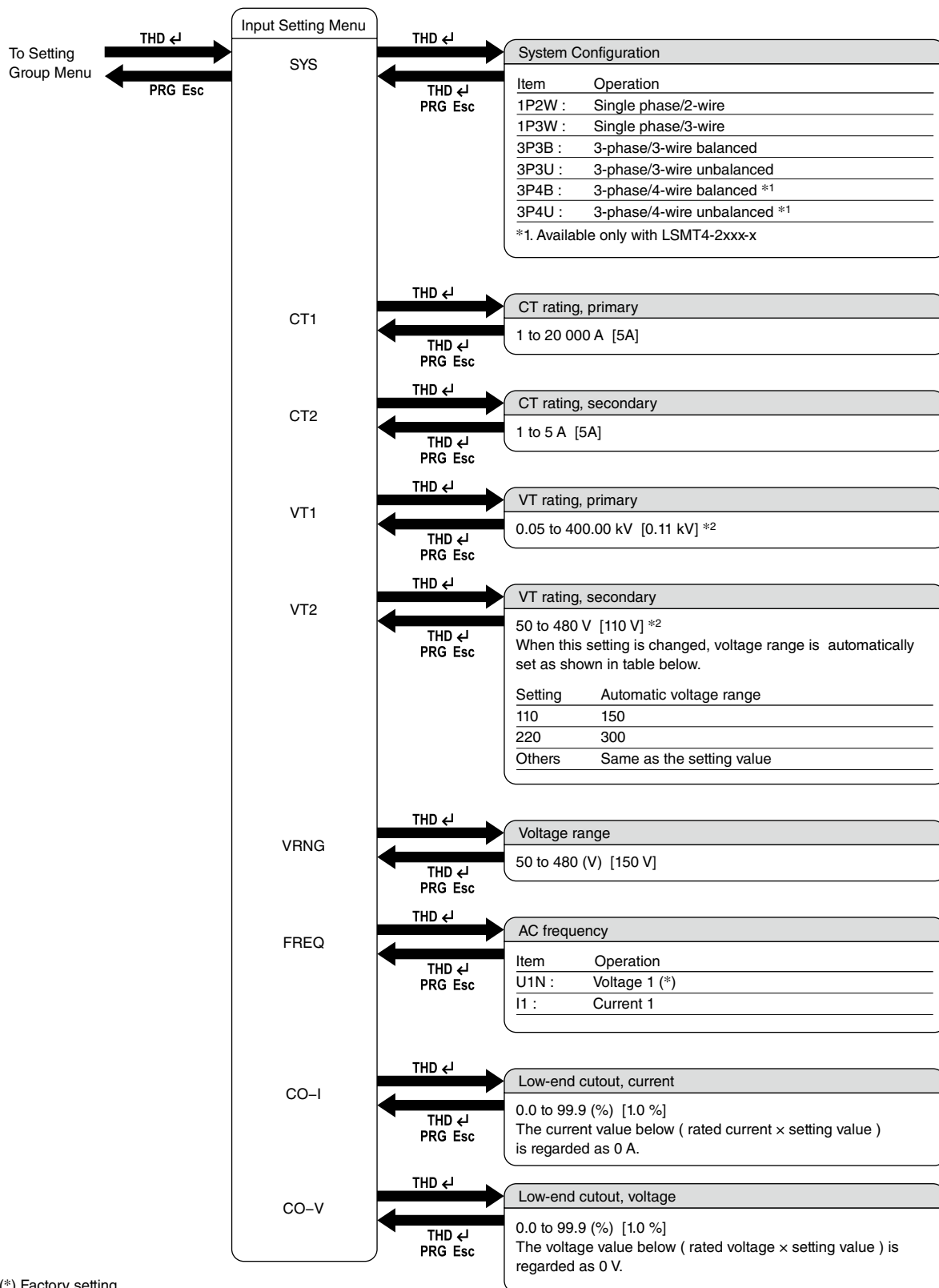

(*) Factory setting

*2. Set rated voltage for VT according to the table shown below.

System Configuration	Voltage
Single phase/2-wire	Voltage between V1 – N 50 – 277 V
3-phase/3-wire	Line-to-line voltage 50 – 480 V
Single phase/3-wire	Voltage between V1 – N 50 – 277 V
3-phase/4-wire	Phase voltage 50 – 277 V

■ ENTER PULSE OUTPUT SETTING MENU

• Flow chart

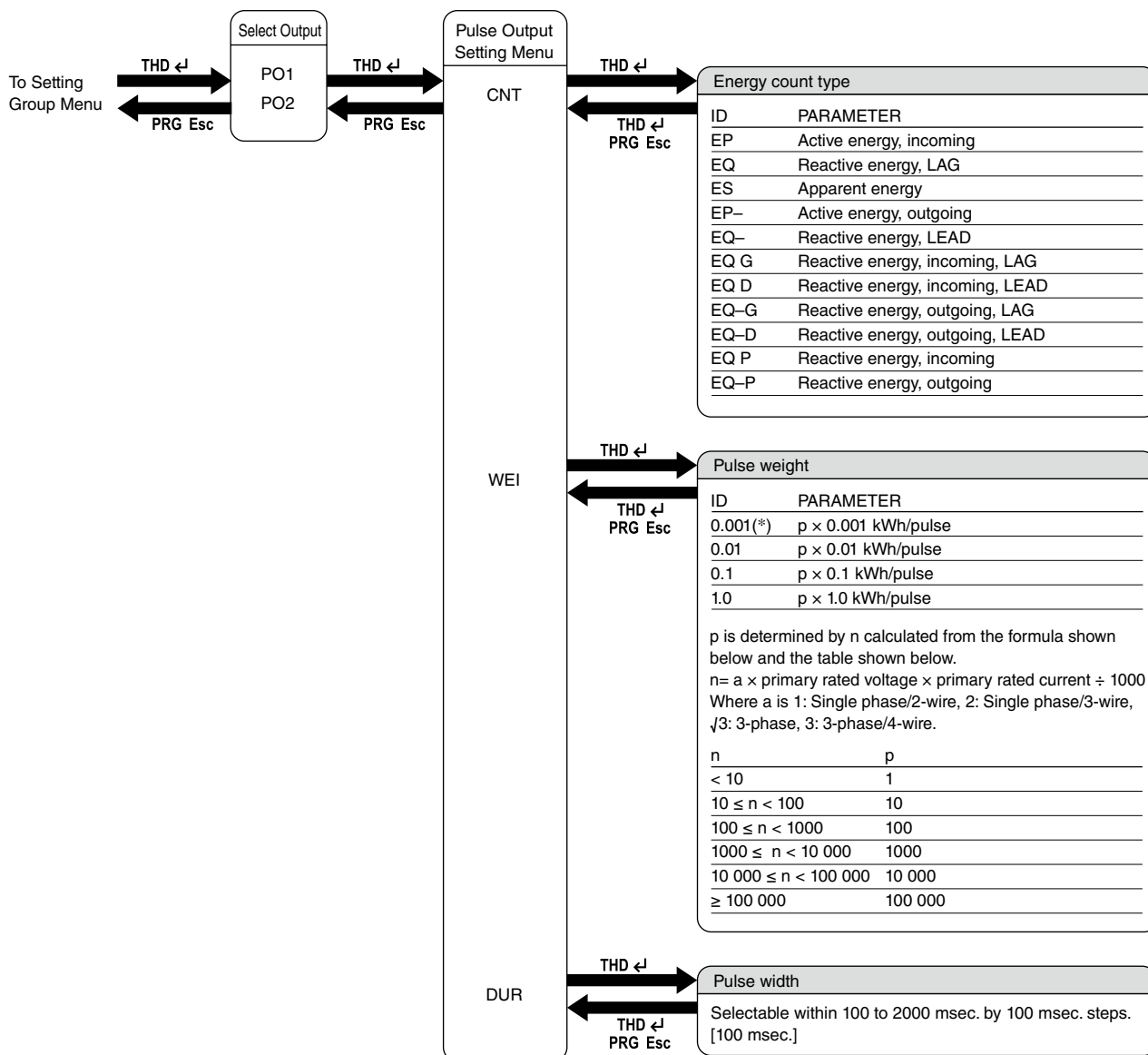

■ AOUT ANALOG OUTPUT SETTING MENU

• Flow chart

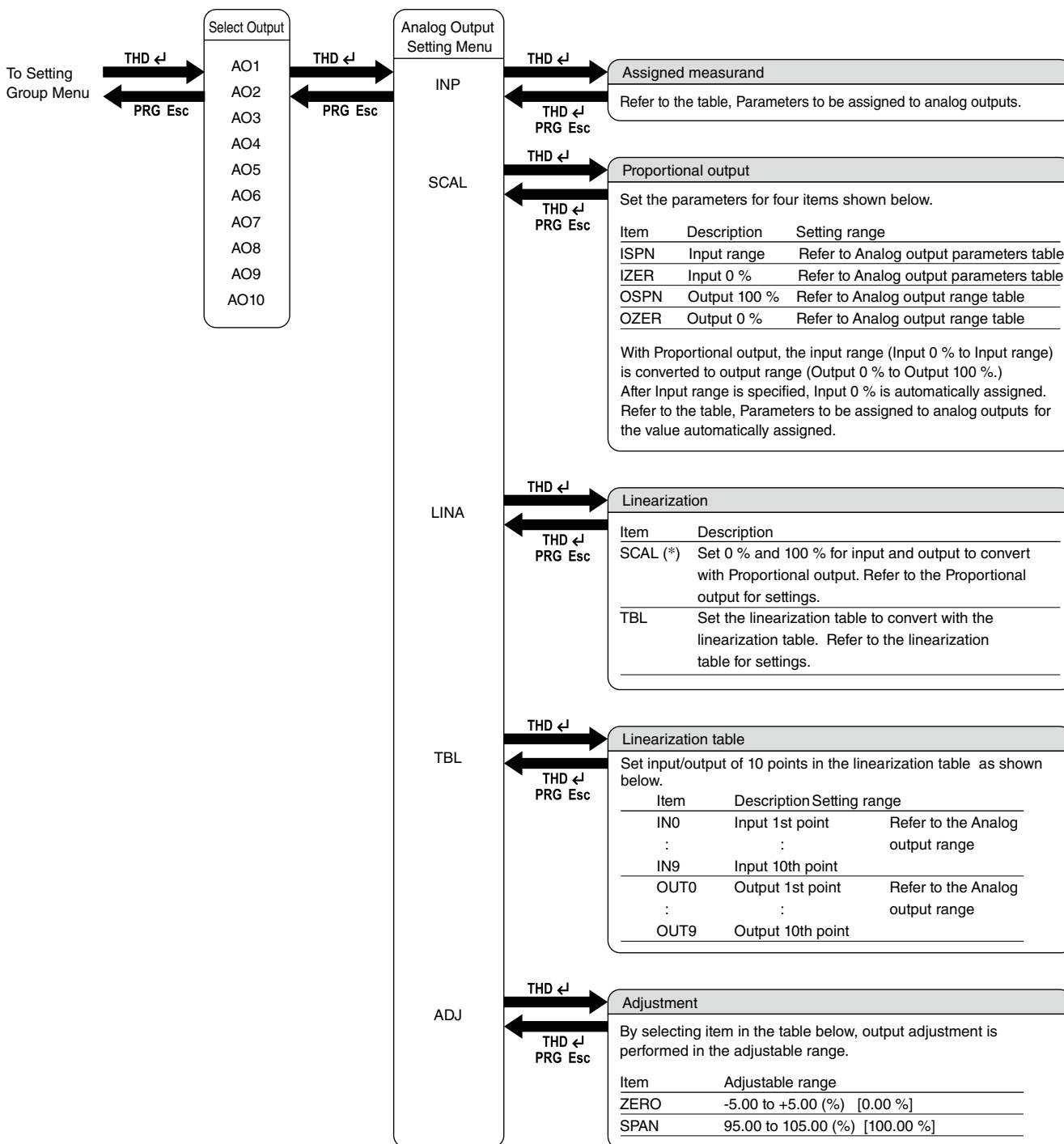

•Analog output range

Model number	Output rating	Available setting range
LSMT4-xxAx-x	4.00 to 20.00 (mA)	3.20 to 20.80 (mA)
LSMT4-xx4x-x	0.000 to 10.000 (V)	-0.500 to +10.500 (V)
LSMT4-xx5x-x	0.000 to 5.000 (V)	-0.250 to +5.250 (V)
LSMT4-xx6x-x	1.000 to 5.000 (V)	0.800 to 5.200 (V)

• Analog output parameters

Item	Description	Input range -100% -75% -50% -25% 0% 25% 50% 75% 100%	Available setting range for input range	Auto setting value for input 0 %
NONE	Not assigned		—	—
I1 I2 I3 IN	Current, Line 1 Current, Line 2 Current, Line 3 Neutral current	0 CT secondary rating	0.00 to 120.00% [0.00 to 100.00%]	0.00
U12 U23 U31 U1N U2N U3N	Phase to phase, Line 1 – 2 Phase to phase, Line 2 – 3 Phase to phase, Line 3 – 1 Phase voltage, Phase 1 Phase voltage, Phase 2 Phase voltage, Phase 3	0 Voltage range	0.00 to 120.00% [0.00 to 100.00%]	0.00
P P1 P2 P3	Active power Active power, Phase 1 Active power, Phase 2 Active power, Phase 3	-P (outgoing) 0 (incoming) P	-120.00 to 120.00% [0.00 to 100.00%]	0.00
Q Q1 Q2 Q3	Reactive power Reactive power, Phase 1 Reactive power, Phase 2 Reactive power, Phase 3	-P (LEAD) 0 (LAG) P	-120.00 to 120.00% [-100.00 to 100.00%]	Sign inversion value of the input range
S S1 S2 S3	Apparent power Apparent power, Phase 1 Apparent power, Phase 2 Apparent power, Phase 3	0 P	0.00 to 120.00% [0.00 to 100.00%]	0.00
PF PF1 PF2 PF3	Power factor Power factor, Phase 1 Power factor, Phase 2 Power factor, Phase 3	0 (LEAD) 1 (LAG) 0	-100.00 to 100.00% [-50.00 to 50.00%]	Sign inversion value of the input range
F	Frequency	45 55 65	0.00 to 100.00% [0.00 to 100.00%]	—
T-Q	Reactive power for bidirectional current	-P (LEAD) 0 (LAG) P -P (LEAD) 0 (LAG) P When LEAD/LAG range of power rating is set, the unit outputs 0 to 50 % for outgoing and outputs; 50 to 100 % for incoming.	-100.00 to 100.00% [-100.00 to 100.00%]	Sign inversion value of the input range
T-PF	Power factor for bidirectional current	0 (LEAD) 1 (LAG) 0 (LEAD) 1 (LAG) P When LEAD/LAG range of power factor is set, the unit outputs 0 to 50 % for outgoing; 50 to 100 % for incoming.	-100.00 to 100.00% [-50.00 to 50.00%]	Sign inversion value of the input range

• Calculation of P (power rating)

P (power rating) is automatically determined by rounding to the unit (CT secondary rating × 100 (W)) after calculated with following formula by system configuration and secondary rating of CT/VT.

It is available not to round with option setting.

Power rating = (CT secondary rating) × (VT secondary rating) × a

Calculation example

System configuration	a	Rating	Power rating
Single phase/2-wire	1	110V/5A	500W
		220V/5A	1000W
Single phase/3-wire	2	110V/5A	1000W
3-phase/3-wire	2	110V/5A	1000W
		220V/5A	2000W
3-phase/4-wire	3	220V/5A	3500W

• Inversion of output 0 % to 100 %

When negative value is set to input range, output is inverted. For example, -50.00 % is set to input range of reactive power, 50.00 % is automatically set to input 0 % and then output characteristic is the figure shown below.

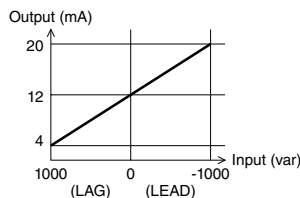

• Output characteristics of reactive power and power factor

Output characteristics of reactive power and power factor when outgoing change depending on the 'Reactive Power Sign' setting as shown below.

In order to output power factor and reactive power when power factor is near 0, choose IEC.

REACTIVE POWER SIGN	IEC	SPC
REACTIVE POWER		
POWER FACTOR		

Note 1: The above characteristics are when the reactive power range is set to 100% and the power factor range is set to 50%.

Note 2: Output characteristics of IEC is available with firmware version 1.30 or higher.

■ OUTPUT EXAMPLES

• Reactive power for bidirectional current

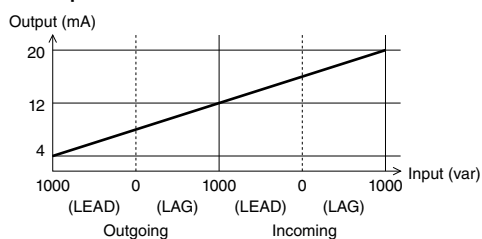

• Power factor for bidirectional current

Range-100 to 100%

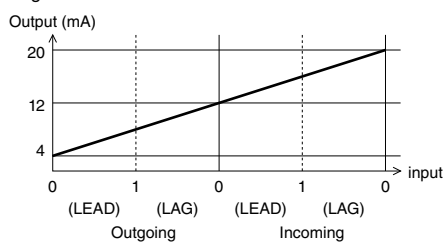

Range-50 to 50%

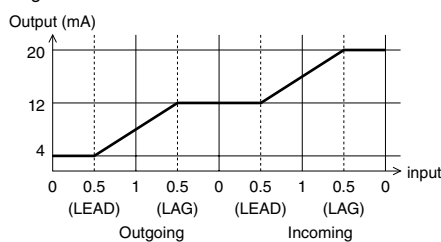

■ OPT OPTION SETTING MENU

• Flow chart

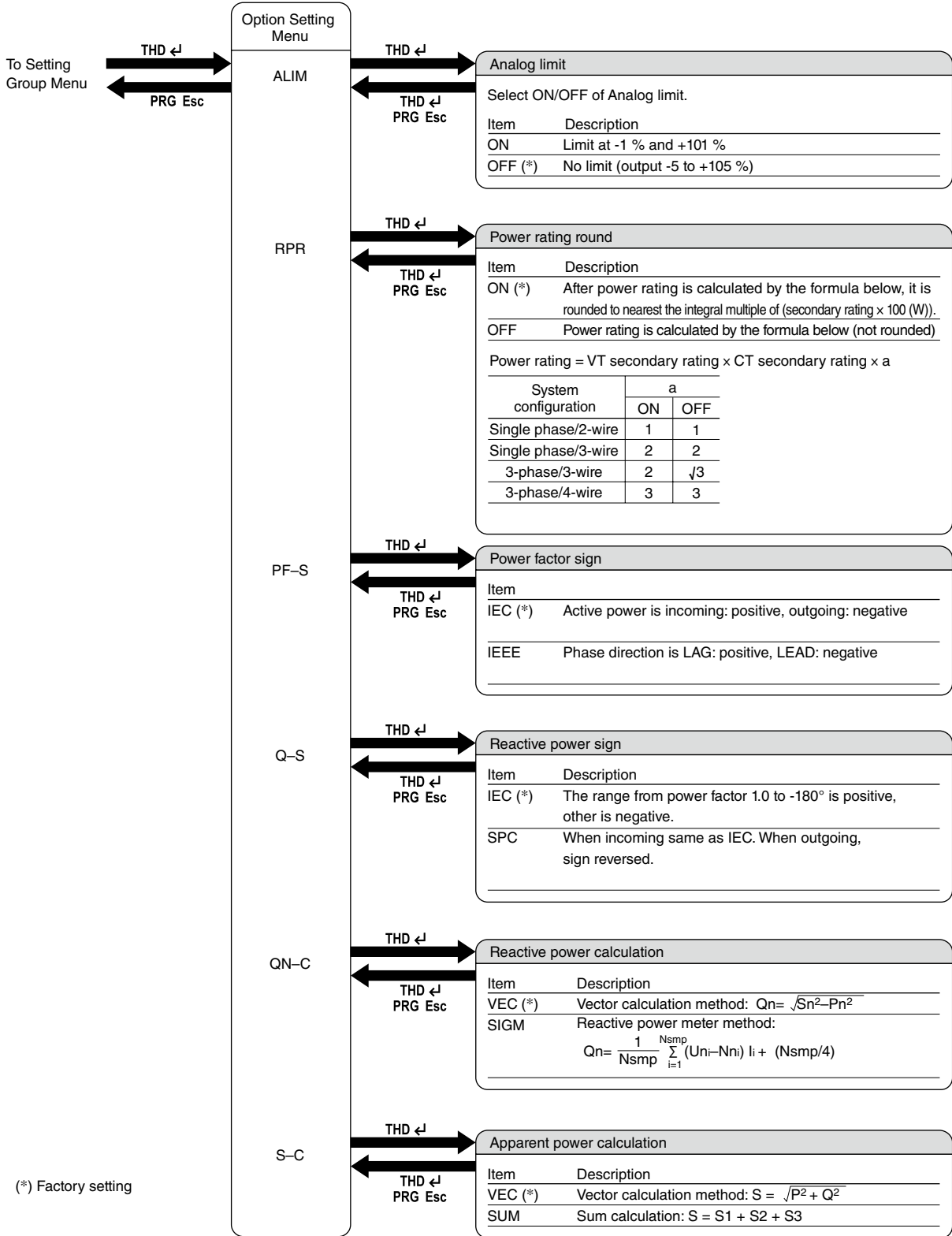

■ MNT E MAINTENANCE MENU

• Flow chart

