

**SIGNAL CONVERTER
(PC programmable)**MODEL **M8XV2****BEFORE USE**

Thank you for choosing us. Before use, please check contents of the package you received as outlined below. If you have any problems or questions with the product, please contact our sales office or representatives.

■ PACKAGE INCLUDES:

Signal conditioner(1)

■ MODEL NO.

Confirm Model No. marking on the product to be exactly what you ordered.

■ INSTRUCTION MANUAL

This manual describes necessary points of caution when you use this product, including installation, connection and basic maintenance procedures.

The unit is programmable using the PC Configurator Software. For detailed information on the PC configuration, refer to the JXCON users manual. The JXCON PC Configurator Software is downloadable at our web site.

POINTS OF CAUTION**■ POWER INPUT RATING & OPERATIONAL RANGE**

- Locate the power input rating marked on the product and confirm its operational range as indicated below:
24V DC rating: 24V \pm 10%, approx. 50mA
(70mA for current output)

■ GENERAL PRECAUTIONS

- Before you remove the unit or mount it, turn off the power supply and input signal for safety.

■ ENVIRONMENT

- Indoor use.
- When heavy dust or metal particles are present in the air, install the unit inside proper housing with sufficient ventilation.
- Do not install the unit where it is subjected to continuous vibration. Do not subject the unit to physical impact.
- Environmental temperature must be within 0 to 55°C (32 to 131°F) with relative humidity within 30 to 95% RH in order to ensure adequate life span and operation.
- Be sure that the ventilation slits are not covered with cables, etc.

■ WIRING

- Do not install cables close to noise sources (relay drive cable, high frequency line, etc.).
- Do not bind these cables together with those in which noises are present. Do not install them in the same duct.

■ AND

- The unit is designed to function as soon as power is supplied, however, a warm up for 10 minutes is required for satisfying complete performance described in the data sheet.

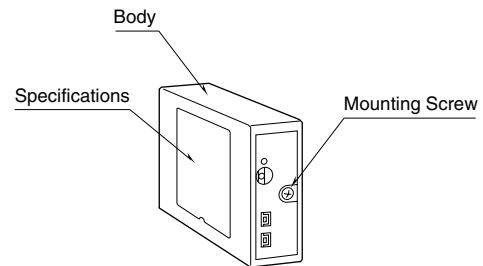
COMPONENT IDENTIFICATION**INSTALLATION**

Use Installation Base (model: M8BSx).

TERMINAL CONNECTIONS

Connect the unit as in the diagram below.

EXTERNAL DIMENSIONS unit: mm (inch)

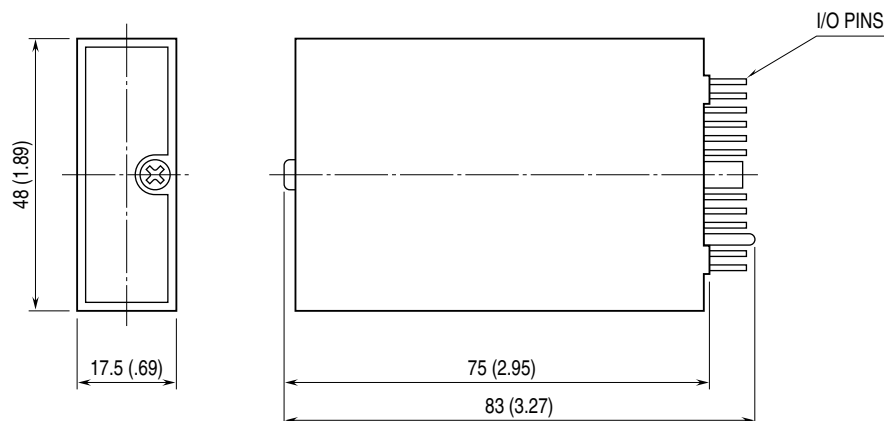

CONNECTION DIAGRAM

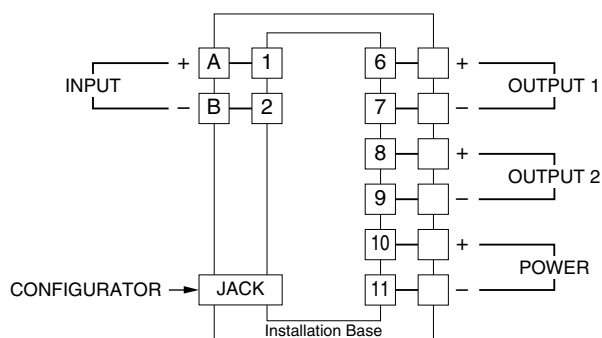

CHECKING

- 1) Terminal wiring: Check that all cables are correctly connected according to the connection diagram.
- 2) DIP switches: Check the input range selector and output range selector setting.
- 3) Power input: Check the power input voltage.
- 4) Input: Check that the input signal is within 0 – 100% of the full-scale.
- 5) Output: Check that the load resistance meets the described specifications.
- 6) Status indicator LED: Check that it blinks in a regular pattern.

CALIBRATION

This unit is calibrated at the factory to meet the ordered specifications, therefore you usually do not need any calibration.

For matching the signal to a receiving instrument or in case of regular calibration, adjust the output as explained in the following.

■ ZERO/SPAN & UP/DOWN SWITCHES

Fine zero and span adjustments can be done with the ZERO/SPAN Selector and UP/DOWN switches. Calibrated values are stored in the non-volatile memory, which will not be lost even when you turn off power supply to the unit.

The output 1 and output 2 can be independently adjustable. Zero and span are respectively set to 0% and 100% at the factory, and field calibration can be reset to ex-factory setting if necessary.

Adjustable range: $\pm 5\%$

Zero/Span Selector

ZERO: UP/DOWN switches usable for zero adjustment.

OFF: UP/DOWN switches unavailable.

SPAN: UP/DOWN switches usable for span adjustment.

UP/DOWN Switches

UP: Pressing UP increases adjusted values.

DOWN: Pressing DOWN decreases adjusted values.

■ FRONT VIEW

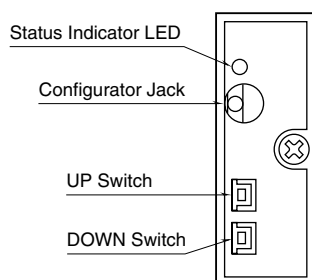

■ BOTTOM VIEW

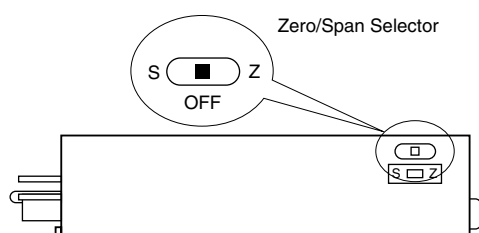

Zero/Span Selector

MODE	SW POSITION
SPAN	S
OFF	■
ZERO	Z

■ HOW TO CALIBRATE THE ZERO & SPAN

Use a signal source and measuring instruments of sufficient accuracy level. Turn the power supply on and warm up for more than 10 minutes.

The output 1 and output 2 adjustments are linked except for (2) and (6).

- 1) Apply 0% input.
- 2) Select the Output 1 Zero: Slide the Zero/Span Selector to the position Z.
Select the Output 2 Zero: Slide the Zero/Span Selector to the position Z while pressing UP switch.
- 3) Press UP or DOWN switch and adjust the output to 0%. Incrementing speed will be doubled when you keep pressing a switch.
- 4) Put the Zero/Span Selector back to the position OFF.
- 5) Apply 100% input.
- 6) Select the Output 1 Span: Slide the Zero/Span Selector to the position S.
Select the Output 2 Span: Slide the Zero/Span Selector to the position S while pressing UP switch.
- 7) Press UP or DOWN switch and adjust the output to 100%. Incrementing speed will be doubled when you keep pressing a switch.
- 8) Put the Zero/Span Selector back to the position OFF.
- 9) Check Zero and Span adjustments again with 0% and 100% input respectively.
- 10) If the output value is changed, repeat the above procedure (1) – (9).

■ HOW TO RESET

After you calibrated manually with these switches, you can reset them to its ex-factory state by pressing both UP/DOWN switches at once.

I/O RANGE MODIFICATION

Configurator Software is used to change input ranges over the described range of the selected suffix code. For changing out of this range, set the Input Range Selectors before software adjustment.

For changing output ranges, set the Output Range Selector and then select by Configurator Software.

■ SIDE VIEW

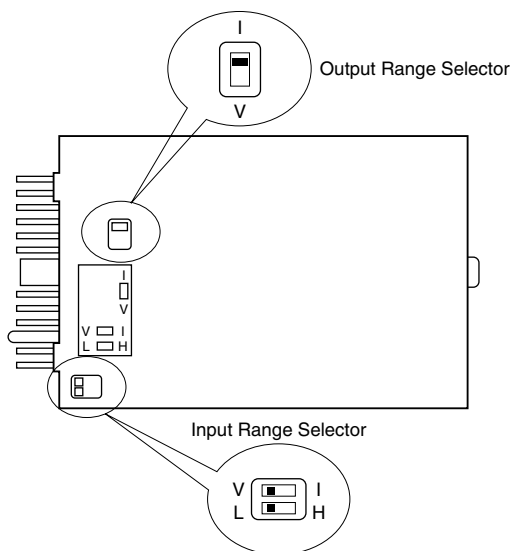

Input Range Selector

INPUT RANGE	TOP SW	BOTTOM SW
Z1: 0 – 50 mA DC	I	L
S1: -1 – +1 V DC	V	L
S2: -10 – +10 V DC	V	H

Output Range Selector

OUTPUT RANGE	SW POSITION
V2Z1: -10 – +10 V / 0 – 20 mA DC	I
V2V2: -10 – +10 V / -10 – +10 V DC	V

STATUS INDICATOR LED

The unit is provided with a status indicator LED which blinks in different patterns indicating various status of its CPU. When it is functioning within normal parameters, the LED blinks in a regular pattern of ON and OFF.

The following figure indicates typical patterns.

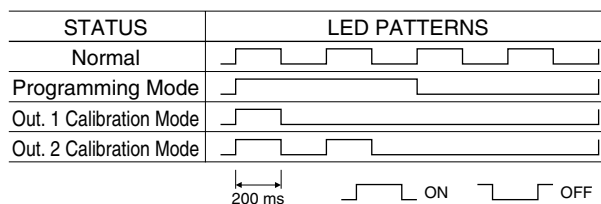

MAINTENANCE

Regular calibration procedure is explained below:

■ CALIBRATION

Warm up the unit for at least 10 minutes. Apply 0%, 25%, 50%, 75% and 100% input signal. Check that the output signal for the respective input signal remains within accuracy described in the data sheet. When the output is out of tolerance, recalibrate the unit according to the “CALIBRATION” explained earlier.

LIGHTNING SURGE PROTECTION

We offer a series of lightning surge protector for protection against induced lightning surges. Please contact us to choose appropriate models.