

MULTI POWER TRANSDUCER
(self-powered, PC programmable)

MODEL **M5XWT**

BEFORE USE

Thank you for choosing M-System. Before use, please check contents of the package you received as outlined below. If you have any problems or questions with the product, please contact M-System's Sales Office or representatives.

■ PACKAGE INCLUDES:

Signal conditioner(1)

■ MODEL NO.

Confirm Model No. marking on the product to be exactly what you ordered.

■ INSTRUCTION MANUAL

This manual describes necessary points of caution when you use this product, including installation, connection and basic maintenance procedures.

The M5XWTU is programmable using the PC Configurator Software. For detailed information on the PC configuration, refer to the PMCFG users manual. The PMCFG PC Configurator Software is downloadable at M-System's web site: <https://www.m-system.co.jp>

Refer to EM-2768-B for the use of Modbus.

POINTS OF CAUTION

■ AUXILIARY POWER

- M5XWTU does not have input terminals for auxiliary power. The power for operation is generated from the voltage input terminals P1 - P2, with consuming 3 VA between these terminals.

■ GENERAL PRECAUTIONS

- Before you remove the unit or mount it, turn off the input signal for safety.

■ ENVIRONMENT

- Indoor use.
- When heavy dust or metal particles are present in the air, install the unit inside proper housing with sufficient ventilation.
- Do not install the unit where it is subjected to continuous vibration. Do not subject the unit to physical impact.
- Environmental temperature must be within -20 to +65°C (-4 to +149°F) with relative humidity within 30 to 90% RH in order to ensure adequate life span and operation.

■ WIRING

- Do not install cables close to noise sources (relay drive cable, high frequency line, etc.).
- Do not bind these cables together with those in which noises are present. Do not install them in the same duct.
- Install lightning surge protectors for those wires connected to remote locations.

■ AND

- The unit is designed to function as soon as power is supplied, however, a warm up for 10 minutes is required for satisfying complete performance described in the data sheet.

COMPONENT IDENTIFICATION

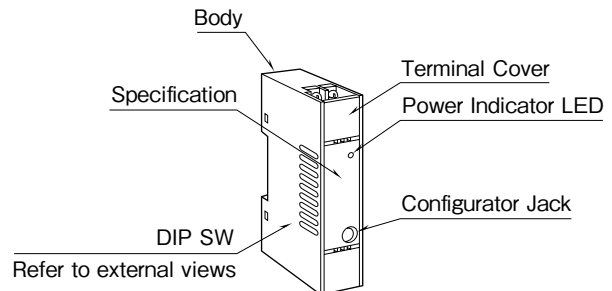

INSTALLATION

Set the unit so that its DIN rail adapter is at the bottom.

■ MOUNTING THE UNIT ON A DIN RAIL

- Hang the upper hook at the rear side of unit on the DIN rail.
- Push in the lower in keeping pressing the unit to the DIN rail.

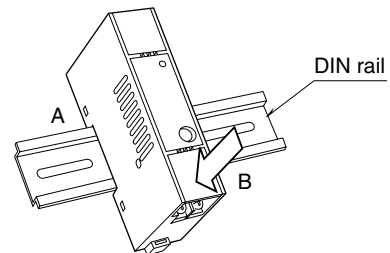

■ REMOVING THE UNIT

- Pull down the DIN rail adaptor using a minus screwdriver.
- Pull out the lower part of the unit.
- Remove the upper part from the DIN rail.

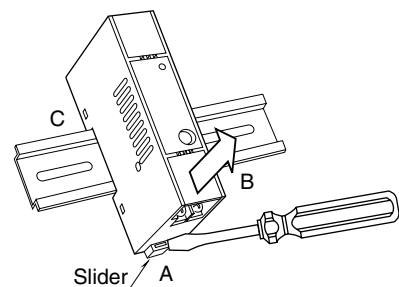

TERMINAL CONNECTIONS

Connect the unit as in the diagram below or refer to the connection diagram on the side of the unit.

EXTERNAL DIMENSIONS unit: mm [inch]

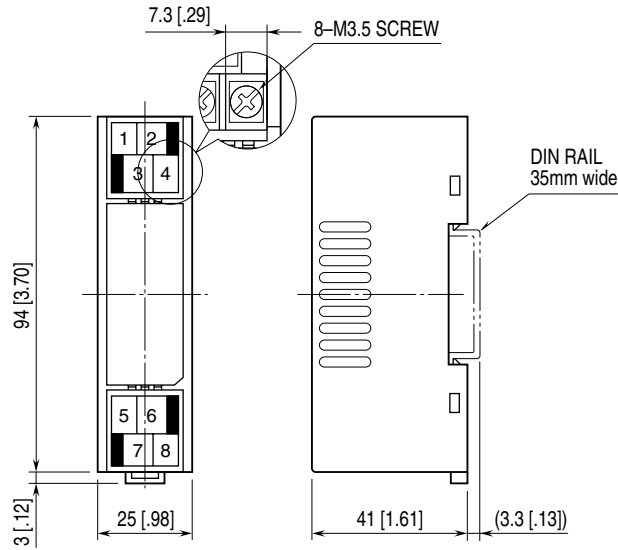

• When mounting, no extra space is needed between units.

CONNECTION DIAGRAM

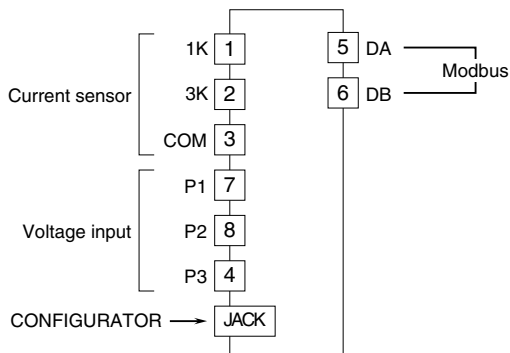

TERMINAL CONNECTIONS

System/ Application	Terminal	System/ Application	Terminal
Single-phase/ 2-wire		Single-phase/ 3-wire	

Note: Use CLSE for CT.

Grounding is unnecessary for low-voltage circuit.

Apply voltage to P1 - P2 to generate internal power when using simplified measuring mode (fixed voltage value and power factor).

MODBUS WIRING CONNECTION

■ HOST PC WIRING

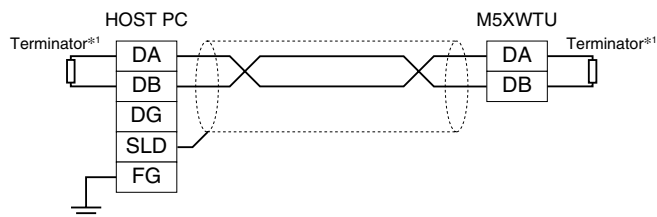

*1. Turn the terminator DIP SW ON to use internal terminator.

WIRING INSTRUCTIONS

■ SCREW TERMINAL

Torque: 0.8 N·m

EXTERNAL VIEWS

■ SIDE VIEW

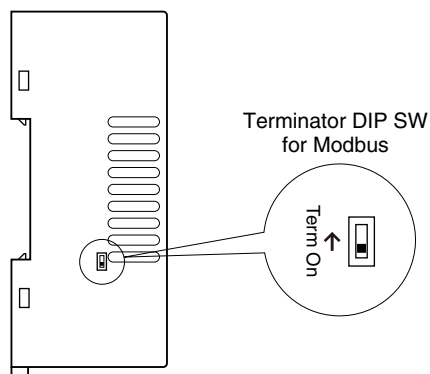

■ FRONT VIEW

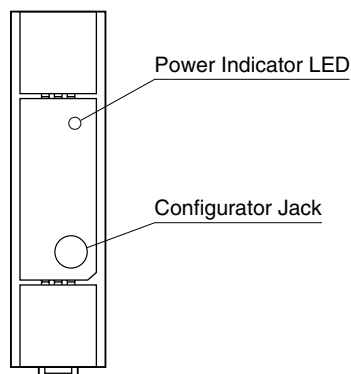

PC CONFIGURATOR

Configuration by the PC is required for each setting.

Refer to the users manual for the PMCFG for detailed operation of the software program.



CHECKING

- 1) Terminal wiring: Check that all cables are correctly connected according to the connection diagram.
- 2) Check DIP switch setting.
- 3) Power input voltage: Check voltage across the terminal 7 – 8 – 4 with a multimeter.

POWER INDICATOR LED

The transmitter is provided with a power indicator LED which blinks in different patterns indicating various operating status.

The following figure indicates typical patterns.

TRANSMITTER STATUS	LED ON OFF PATTERNS
Normal	
Downloading the setting Loop test	
Abnormal Operation (corruption of configuration data)	

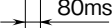

LIGHTNING SURGE PROTECTION

M-System offers a series of lightning surge protector for protection against induced lightning surges. Please contact M-System to choose appropriate models.